



820/860/880/970/980

**Loader Backhoes
Chargeuses Pelleteuses
Caricatore escavatore**

**Parts Catalogue
Catalogue Pieces
Catalogo componenti**

6199042M3

Issue 01

Jan - 06



General Information
Informations générales
Información general



Operator's Environment
Environnement opérateur
Entorno del operario



Accessories
Accessoires
Accesorios



Electrics
Équipement électrique
Sistema eléctrico



Loader Buckets
Bennes de chargeur
Cucharas de la cargadora



Chassis And Bodywork
Châssis et carrosserie
Chasis y carrocería



Digger Quick Attach
Dispositif de fixation rapide pour bras de pelle
Enganche rápido de la excavadora



Front Axle and Steer System
Essieu avant et direction
Eje delantero y sistema de dirección



Digger Boom and Dipperstick
Flèche et bras de pelle
Aguilón y pluma de la excavadora



Wheels And Tyres
Roues et pneus
Ruedas y neumáticos



Digger Swing System
Système de pivotement de la pelle
Sistema de oscilación de la excavadora



Drive Train and Brakes
Transmission et freins
Transmisión y frenos



Main Hydraulics
Circuit hydraulique principal
Sistema hidráulico principal



Engine and Ancillary Equipment
Moteur et auxiliaires
Motor y equipos auxiliares



Loader
Chargeuse
Cargadora







Legal Requirements
Obligations légales
Requisitos legales

General Information

1 PART NUMBER REFERENCE LIST

(i) EXAMPLE

A	B	C	D	E	F	G	H	J
1	882 782 M91				1	Differential	Differential	Diferencial
2	1885 318 M91	1			1	Kit	Jeu	Juego
3		2		REF.2	1	Crownwheel	Couronne	Corona
4		2		REF.2	1	Pinion	Pignon	Piñón
5	825 776 M1	2		1234567	1	Bolt	Boulon	Perno
6	960 620 M1	2		1234567	1	Bolt	Boulon	Perno

(ii) EXPLANATION

- Col. A Illustration reference number.
 Col. B Part Number.
 Col. C Item also a component of an assembly.
 See assembly illustration number indicated.
 Col. D/E Comment (see symbols and notes).
 Col. F Quantity required (See notes below).
 Col. G, H, J Description - Language format: English, French, Spanish.

(iii) SPECIAL NOTES

The quantity shown in column 'F' is the quantity required for the particular application that is illustrated. Where these parts are components of an assembly, this refers to the quantity in one assembly or sub-assembly.
 For parts such as shims, washers, etc., an 'X' in the quantity column means "Quantity as Required".
 The parts book number, issue number and date are shown in the lower left hand corner of the page. The issue number is printed in brackets.

2 HAND AMENDMENTS

Urgent information is issued in a "change bulletin".
 To make it easy to enter the information in this parts book, the bulletin page will be divided into eight columns.
 Col. A Page number
 Col. B Illustration reference number
 Col. C Part number

- Col. D Change information symbols
 + means 'add the following information'.
 - means 'delete the following information'.
 → means 'amend to read'.
 Col. E An asterisk indicates that the change is due to a printing error.
 Col. F New part number and description.
 Col. G Serial or engine number.
 Col. H Quantity (see previous special notes).

3 RE-ISSUES

When a parts book is completely revised for re-issue, the parts book number suffix will be advanced (e.g. M1 to M2). A revision will incorporate all the change bulletins, plus amendments which have not previously been issued.

4 SAFETY NOTE





When ordering replacement parts to which safety decals were originally attached, the appropriate safety decals must be ordered and fitted.



Informations générales

1 LISTES DES NUMEROS DE REFERENCE DES PIECES

(i) **EXAMPLE**

A	B	C	D	E	F	G	H	J
1	882 782 M91				1	Differential	Differential	Diferencial
2	1885 318 M91	1			1	Kit	Jeu	Juego
3		2		REF.2	1	Crownwheel	Couronne	Corona
4		2		REF.2	1	Pinion	Pignon	Piñón
5	825 776 M1	2		1234567	1	Bolt	Boulon	Perno
6	960 620 M1	2		1234567	1	Bolt	Boulon	Perno

(ii) **EXPLICATIONS**

- Col. A Numéro de référence de l'illustration.
Col. B Numéro de pièce.
Col. C Pièce comprise dans l'ensemble dont le numéro de référence de l'illustration est indiqué.
Col. D/E Remarque (voir symboles et notes).
Col. F Quantité (voir note ci-dessous).
Col. G, H, J Designation ordre des langues: Anglais, Français, Espagnol.

(iii) **NOTES SPECIALES**

La quantité indiquée dans la colonne 'F' est celle applicable à l'ensemble illustré sur la page adjacente, le nombre indique donc la quantité dans l'ensemble ou sous-ensemble et non pour la machine complète.
Pour des pièces telles que cales d'épaisseur, rondelles, etc., un 'X' dans la colonne quantité signifie "suivant besoin".
Le numéro du catalogue, le numéro d'émission et la date sont indiqués dans le coin inférieur de la page. Le numéro d'émission est imprimé entre parenthèses.

2 CORRECTIONS MANUELLES

Les informations urgentes sont émises sur les "Bulletins de Changement" sous forme de corrections manuelles.

Pour faciliter l'entrée de ces informations dans la catalogue, la page du bulletin sera divisée en huit colonnes.

- Col. A Numéro de page.
Col. B Numéro de référence de l'illustration.
Col. C Numéro de pièce.

- Col. D Symboles d'informations de modifications.
+ signifie 'ajouter l'information suivante'.
- signifie 'supprimer l'information suivante'.
→ signifie 'modifier pour lire'.
Col. E Un astérisque indique que la modification est due à une erreur d'impression.
Col. F Nouveau numéro de pièce et désignation.
Col. G Numéro de série machine ou numéro de moteur.
Col. H Quantité (voir notes spéciales sur la page précédente).

3 REEDITIONS

Quand un catalogue de pièces de rechange est complètement révisé pour réédition, le suffixe du numéro de catalogue sera avancé (par exemple: M1 à M2), une révision incorporera tous les bulletins de changements ainsi que les modifications non émises précédemment.

4 NOTES DE SECURITE





Lors du remplacement de pièces munies à l'origine d'une décalcomanie de sécurité. La décalcomanie correspondante doit aussi être commandée et montée.



Información general

1 LISTAS CON LOS NUMEROS DE REFERENCIA DE LAS PIEZAS

(i) EJEMPLO

A	B	C	D	E	F	G	H	J
1	882 782 M91				1	Differential	Differential	Diferencial
2	1885 318 M91	1			1	Kit	Jeu	Juego
3		2		REF.2	1	Crownwheel	Couronne	Corona
4		2		REF.2	1	Pinion	Pignon	Piñón
5	825 776 M1	2		1234567	1	Bolt	Boulon	Perno
6	960 620 M1	2		1234567	1	Bolt	Boulon	Perno

(j) EXPLICACIÓN

- Col. A Número de referencia del dibujo.
Col. B Número de pieza.
Col. C Pieza incluida en el conjunto cuyo número de referencia de dibujo se indica.
Col. D/E Comentario (ver los símbolos y las notas).
Col. F Cantidad necesaria (ver nota a continuación).
Col. G, H, J, K Descripción - Formato de idiomas - Inglés, Francés, Alemán, Italiano, Español.

(ii) NOTAS ESPECIALES

La cantidad indicada en la columna 'F' es la cantidad necesaria para el conjunto que figura en la ilustración contigua. El número por lo tanto indica la cantidad pertinente al conjunto o subconjunto y no a la máquina completa.
Para determinadas piezas como espaciadores, arandelas, etc., una X en la columna de cantidades indica "Según Requisitos".
La referencia de número de catálogo y fecha de edición están impresas en el pie de la página. El número de edición está indicado entre paréntesis.

2 CORRECCIONES MANUALES

Las informaciones de carácter urgente serán emitidas en los "boletines de modificación" bajo la forma de correcciones manuales. Para facilitar la inserción de esta información en el catálogo la página del boletín será dividida en ocho columnas.

- Col. A Número de página.
Col. B Número de referencia del dibujo.
Col. C Número de pieza.

- Col. D Símbolos de información de modificación:
+ significa 'añadir la siguiente información'.
- significa 'anular la siguiente información'.
→ significa 'corregir para que diga'.
Col. E Un asterisco indica que la modificación es debida a un error de imprenta.
Col. F Nuevo número de pieza y designación.
Col. G Número de serie de la máquina o número de motor.
Col. H Cantidad (ver notas especiales en páginas precedentes).

3 REEDICIONES

















Cuando un catálogo es revisado en su totalidad para su reedición el sufijo del número de catálogo deberá ser modificado (por ejemplo M1 a M2) una revisión deberá incluir todos los boletines de cambio además de las modificaciones no editadas anteriormente.

4 AVISO DE SEGURIDAD

Cuando se piden piezas de repuesto que originalmente llevaban calcomanías de seguridad hay que pedir y colocar también las calcomanías apropiadas.



Symbols • Symboles • Símbolos

	Right hand	Cote droit	Derecha
	Left hand	Cote gauche	Izquierda
	Width	Largeur	Anchura
	Length	Longueur	Longitud
	Thickness	Epaisseur	Grosor
	Diameter	Diamètre	Diámetro
	Number of teeth/splines	Nombre de dents/cannelures	Número de dientes/estrias
	Top	Haut	Parte superior
	Bottom	Bas	Parte inferior
	From serial or engine number	A partir du numéro de série ou moteur	Desde el número serie o número de motor
	Up to serial or engine number	Jusqu'au numéro de série ou moteur	Hasta el número serie o número de motor
	Repairs and replaces	Répare et remplace	Reemplaza y sustituye
	See page - reference number	Voir page - numéro de référence	Ver página - número de referencia
	Alternative	Alternative	Alternativa
	Not serviced, order	Pas fournies, commander	No suministradas, pedir
	Without or not for... Example:] d [(not for germany)	Sans ou pas pour... Exemple:] D [(Pas pour Allemagne)	Sin o no para... Ejemplo:] D [(No para Alemania)



Symbols • Symboles • Símbolos

D	For Germany only or any text in German only	Pour Allemagne seulement ou en allemand seulement	Para Alemania solamente o cualquier texto en alemán solamente
F	For France only or any text in French only	Pour France seulement ou en français seulement	Para Francia solamente o cualquier texto en francés solamente
I	For Italy only or any text in Italian only	Pour Italie seulement ou en italien seulement	Para Italia solamente o cualquier texto en italiano solamente
GB	For UK. only or any text in English only	Pour le Royaume Uni seulement ou en anglais seulement	Para el Reino Unido solamente o cualquier texto en inglés solamente
E	For Spain or any text in Spanish	Pour Espagne seulement ou espagnol	Para España o cualquier texto en español solamente
NL	For Holland or any text in Dutch	Pour Hollande seulement ou en hollandais	Para Holanda solamente o cualquier texto en holandés solamente
DK	For Denmark or any text in Danish	Pour Danemark seulement ou en danois	Para Dinamarca solamente o cualquier texto en danés solamente
US	For United States of America	Pour les Etats Unis d'Amérique	Para los Estados Unidos de América
N	For Norway or any text in Norwegian	Pour Norvège seulement ou en norvégien	Para Noruega solamente o cualquier texto en noruego solamente
S	For Sweden or any text in Swedish	Pour Suède seulement ou en suédois	Para Suecia solamente o cualquier texto en sueco
P	For Portugal or any text in Portuguese	Pour Portugal seulement ou en portugais	Para Portugal solamente o cualquier texto en portugués solamente



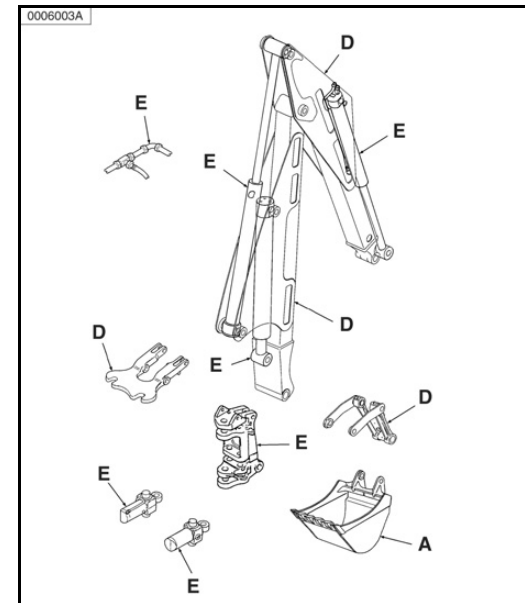
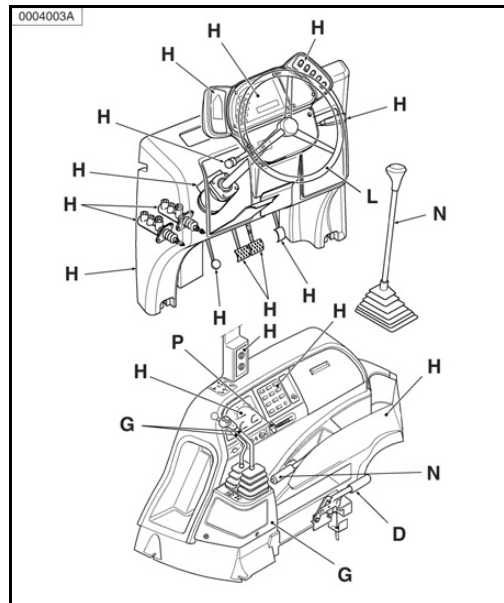
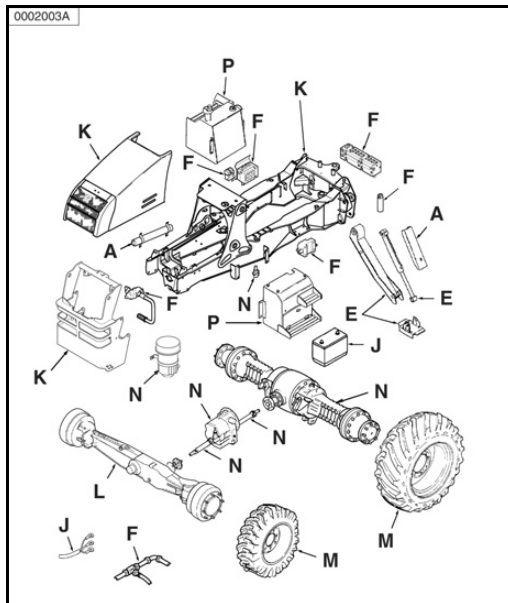
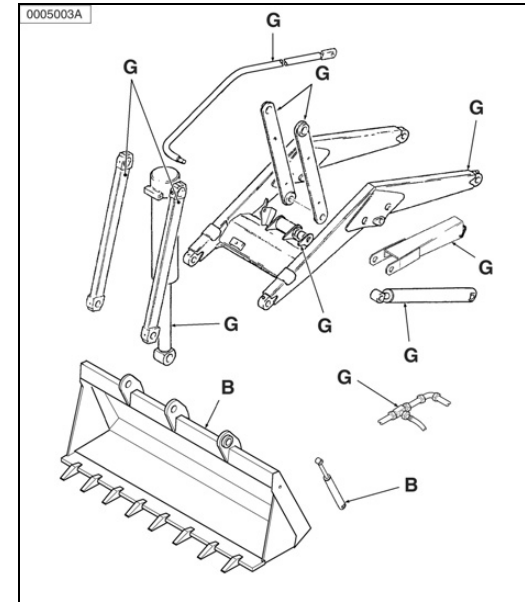
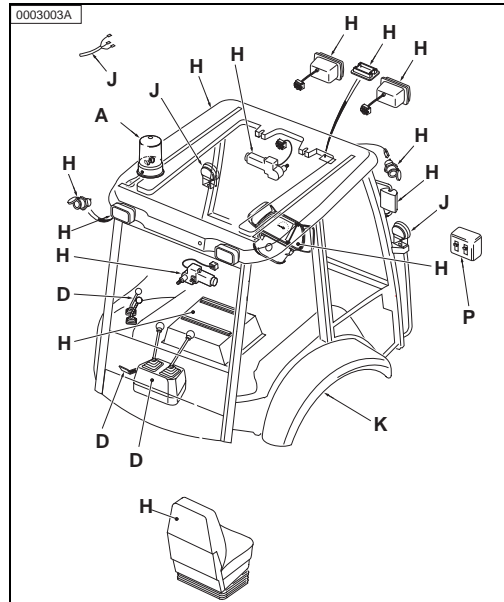
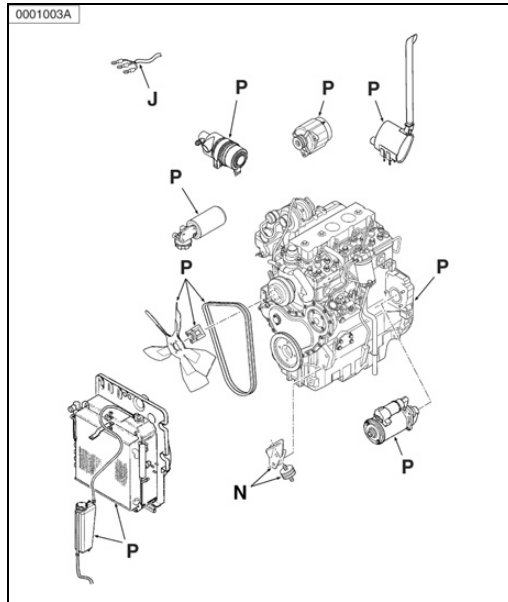

A - Accessories • Accessoires • Accesorios

Bucket Pins Kit	98007C01.1	Coffret de Goupilles de Godet	Juego de pasador de cuchara
Bucket Tooth Kit.....	98010AC01.1	Coffret de Dent de Godet	Juego de diente de cuchara
Bucket Tooth Kit.....	98010C01.1	Coffret de Dent de Godet	Juego de diente de cuchara
Bucket Tooth Kit.....	98011AC01.1	Coffret de Dent de Godet	Juego de diente de cuchara
Bucket Tooth Kit.....	98011C01.1	Coffret de Dent de Godet	Juego de diente de cuchara
CD/Radio Player.....	98134C01.1	CD/Radio	Reproductor de CD/Radio
Craning Valve Kit.....	98002C01.1	Coffret de Distributeur de Commande Manutention	Juego de distribuidor de mando de mantenimiento
Craning Valve Kit.....	98003C01.1	Coffret de Distributeur de Commande Manutention	Juego de distribuidor de mando de mantenimiento
Digger Bucket - Ditch Cleaning	75006C01.1	Godet de Défonceuse - Curage	Cuchara retro - Vaciado
Digger Bucket - Ditch Cleaning	75007C01.1	Godet de Défonceuse - Curage	Cuchara retro - Vaciado
Digger Bucket - Ditch Digging	98096C01.1	Godet de Défonceuse - Curage	Cuchara excavadora - Zanjas
Digger Bucket - Ditch Maintenance.....	98089C01.1	Godet de Défonceuse - Maintenance de Curage	Cuchara excavadora - Mantenimiento zanjas
Digger Bucket - Ditch Maintenance.....	98090C01.1	Godet de Défonceuse - Maintenance de Curage	Cuchara excavadora - Mantenimiento zanjas
Digger Bucket - Ditch Maintenance.....	98102AC01.1	Godet de Défonceuse - Maintenance de Curage	Cuchara excavadora - Mantenimiento zanjas
Digger Bucket - Ditch Maintenance.....	98102C01.1	Godet de Défonceuse - Maintenance de Curage	Cuchara excavadora - Mantenimiento zanjas
Digger Bucket - Ditch Maintenance.....	98103AC01.1	Godet de Défonceuse - Maintenance de Curage	Cuchara excavadora - Mantenimiento zanjas
Digger Bucket - Ditch Maintenance.....	98103C01.1	Godet de Défonceuse - Maintenance de Curage	Cuchara excavadora - Mantenimiento zanjas
Digger Bucket - JCB	98097AC01.1	Godet de Défonceuse - JCB	Cuchara excavadora - JCB
Digger Bucket - JCB	98097C01.1	Godet de Défonceuse - JCB	Cuchara excavadora - JCB
Digger Bucket - JCB	98098AC01.1	Godet de Défonceuse - JCB	Cuchara excavadora - JCB
Digger Bucket - JCB	98098C01.1	Godet de Défonceuse - JCB	Cuchara excavadora - JCB
Digger Bucket - JCB	98099AC01.1	Godet de Défonceuse - JCB	Cuchara excavadora - JCB
Digger Bucket - JCB	98099C01.1	Godet de Défonceuse - JCB	Cuchara excavadora - JCB
Digger Bucket - JCB	98100AC01.1	Godet de Défonceuse - JCB	Cuchara excavadora - JCB
Digger Bucket - JCB	98100C01.1	Godet de Défonceuse - JCB	Cuchara excavadora - JCB
Digger Bucket - JCB	98101AC01.1	Godet de Défonceuse - JCB	Cuchara excavadora - JCB
Digger Bucket - JCB	98101C01.1	Godet de Défonceuse - JCB	Cuchara excavadora - JCB
Digger Bucket - Medium Profile.....	75008C01.1	Godet de Défonceuse - Profil Moyen	Cuchara retro - Perfil medio
Digger Bucket - Premium	98084C01.1	Godet de Défonceuse	Cuchara excavadora - Superior
Digger Bucket - Premium	98085C01.1	Godet de Défonceuse	Cuchara excavadora - Superior
Digger Bucket - Premium	98086C01.1	Godet de Défonceuse	Cuchara excavadora - Superior
Digger Bucket - Premium	98087C01.1	Godet de Défonceuse	Cuchara excavadora - Superior
Digger Bucket - Premium	98088C01.1	Godet de Défonceuse	Cuchara excavadora - Superior
Digger Bucket - Standard	75001C01.1	Godet de Défonceuse - Standard	Cuchara retro - Estándar
Digger Bucket - Standard	75002C01.1	Godet de Défonceuse - Standard	Cuchara retro - Estándar
Digger Bucket - Standard	75003C01.1	Godet de Défonceuse - Standard	Cuchara retro - Estándar
Digger Bucket - Standard	75004C01.1	Godet de Défonceuse - Standard	Cuchara retro - Estándar
Digger Bucket - Standard	75005C01.1	Godet de Défonceuse - Standard	Cuchara retro - Estándar



A - Accessories • Accessoires • Accesorios

Digger Bucket Linkage	74001AC01.1	Articulations Godet de Défonceuse	Articulaciones de cuchara retro
Digger Bucket Linkage	74001C01.1	Articulations Godet de Défonceuse	Articulaciones de cuchara retro
Digger Bucket Linkage - Case Buckets	74003AC01.1	Articulations Godet de Défonceuse - Godets Case	Articulaciones de cuchara retro - Cucharas case
Digger Bucket Linkage - Case Buckets	74003C01.1	Articulations Godet de Défonceuse - Godets Case	Articulaciones de cuchara retro - Cucharas case
Digger Craning Eye Kit	98020C01.1	Coffret de Œillet de Manutention Pour Défonceuse	Juego de argolla de izado para equipo retro
Digger Craning Eye Kit	98021C10.1	Coffret de Œillet de Manutention Pour Défonceuse	Juego de argolla de izado para equipo retro
Digger Craning Eye Kit	98022C01.1	Coffret de Œillet de Manutention Pour Défonceuse	Juego de argolla de izado para equipo retro
Digger Craning Eye Kit	98023C01.1	Coffret de Œillet de Manutention Pour Défonceuse	Juego de argolla de izado para equipo retro
Dipper - Extendahoe	76050AC01.1	Balancier - Extendahoe	Balancín - Extendahoe
Dipper - Standard	73001AC01.1	Balancier - Standard	Balancín - Estándar
Dipper - Standard	73001C01.1	Balancier - Standard	Balancín - Estándar
Dipper - Standard	73003AC01.1	Balancier - Standard	Balancín - Estándar
Dipper - Standard	73003C01.1	Balancier - Standard	Balancín - Estándar
Engine block heater	98133C01.1	Réchauffeur bloc moteur	Calentador del bloque del motor
Extendahoe Hydraulics Kit - Centremount	98063C01.1	Coffret de Circuit Hydraulique Extendahoe - Montage Pelle Central	Juego de circuito hidráulico Extendahoe - Excavadora de montaje central
Extendahoe Hydraulics Kit - Centremount	98063C02.1	Coffret de Circuit Hydraulique Extendahoe - Montage Pelle Central	Juego de circuito hidráulico Extendahoe - Excavadora de montaje central
Extendahoe Hydraulics Kit - Centremount	98064C01.1	Coffret de Circuit Hydraulique Extendahoe - Montage Pelle Central	Juego de circuito hidráulico Extendahoe - Excavadora de montaje central
Extendahoe Hydraulics Kit - Centremount	98064C02.1	Coffret de Circuit Hydraulique Extendahoe - Montage Pelle Central	Juego de circuito hidráulico Extendahoe - Excavadora de montaje central
Extendahoe Hydraulics Kit - Centremount	98065C01.1	Coffret de Circuit Hydraulique Extendahoe - Montage Pelle Central	Juego de circuito hidráulico Extendahoe - Excavadora de montaje central
Extendahoe Hydraulics Kit - Centremount	98065C02.1	Coffret de Circuit Hydraulique Extendahoe - Montage Pelle Central	Juego de circuito hidráulico Extendahoe - Excavadora de montaje central
Extendahoe Hydraulics Kit - Centremount	98066C01.1	Coffret de Circuit Hydraulique Extendahoe - Montage Pelle Central	Juego de circuito hidráulico Extendahoe - Excavadora de montaje central
Extendahoe Hydraulics Kit - Centremount	98066C02.1	Coffret de Circuit Hydraulique Extendahoe - Montage Pelle Central	Juego de circuito hidráulico Extendahoe - Excavadora de montaje central
Extendahoe Hydraulics Kit - Centremount	98067C01.1	Coffret de Circuit Hydraulique Extendahoe - Montage Pelle Central	Juego de circuito hidráulico Extendahoe - Excavadora de montaje central
Extendahoe Hydraulics Kit - Centremount	98067C02.1	Coffret de Circuit Hydraulique Extendahoe - Montage Pelle Central	Juego de circuito hidráulico Extendahoe - Excavadora de montaje central
Extendahoe Hydraulics Kit - Centremount	98068C01.1	Coffret de Circuit Hydraulique Extendahoe - Montage Pelle Central	Juego de circuito hidráulico Extendahoe - Excavadora de montaje central
Extendahoe Hydraulics Kit - Centremount	98068C02.1	Coffret de Circuit Hydraulique Extendahoe - Montage Pelle Central	Juego de circuito hidráulico Extendahoe - Excavadora de montaje central
Extendahoe Hydraulics Kit - Centremount	98069C01.1	Coffret de Circuit Hydraulique Extendahoe - Montage Pelle Central	Juego de circuito hidráulico Extendahoe - Excavadora de montaje central
Extendahoe Hydraulics Kit - Centremount	98069C02.1	Coffret de Circuit Hydraulique Extendahoe - Montage Pelle Central	Juego de circuito hidráulico Extendahoe - Excavadora de montaje central
Extendahoe Hydraulics Kit - Centremount	98070C01.1	Coffret de Circuit Hydraulique Extendahoe - Montage Pelle Central	Juego de circuito hidráulico Extendahoe - Excavadora de montaje central
Extendahoe Hydraulics Kit - Centremount	98070C02.1	Coffret de Circuit Hydraulique Extendahoe - Montage Pelle Central	Juego de circuito hidráulico Extendahoe - Excavadora de montaje central
Extendahoe Hydraulics Kit - Sideshift	98059C01.1	Coffret de Circuit Hydraulique Extendahoe - Montage de Pelle Latéral	Juego de circuito hidráulico Extendahoe - Excavadora montaje horizontal
Extendahoe Hydraulics Kit - Sideshift	98059C02.1	Coffret de Circuit Hydraulique Extendahoe - Montage de Pelle Latéral	Juego de circuito hidráulico Extendahoe - Excavadora montaje horizontal
Extendahoe Hydraulics Kit - Sideshift	98060C01.1	Coffret de Circuit Hydraulique Extendahoe - Montage de Pelle Latéral	Juego de circuito hidráulico Extendahoe - Excavadora montaje horizontal
Extendahoe Hydraulics Kit - Sideshift	98060C02.1	Coffret de Circuit Hydraulique Extendahoe - Montage de Pelle Latéral	Juego de circuito hidráulico Extendahoe - Excavadora montaje horizontal
Extendahoe Hydraulics Kit - Sideshift	98061C01.1	Coffret de Circuit Hydraulique Extendahoe - Montage de Pelle Latéral	Juego de circuito hidráulico Extendahoe - Excavadora montaje horizontal
Extendahoe Hydraulics Kit - Sideshift	98061C02.1	Coffret de Circuit Hydraulique Extendahoe - Montage de Pelle Latéral	Juego de circuito hidráulico Extendahoe - Excavadora montaje horizontal
Extendahoe Hydraulics Kit - Sideshift	98062C01.1	Coffret de Circuit Hydraulique Extendahoe - Montage de Pelle Latéral	Juego de circuito hidráulico Extendahoe - Excavadora montaje horizontal
Extendahoe Hydraulics Kit - Sideshift	98062C02.1	Coffret de Circuit Hydraulique Extendahoe - Montage de Pelle Latéral	Juego de circuito hidráulico Extendahoe - Excavadora montaje horizontal



A - Accessories • Accessoires • Accesorios

Fan Guard	95023C01.1	Protège-Ventilateur	Protección ventilador
Fan Guard	95024C01.1	Protège-Ventilateur	Protección ventilador
Fork Carrier	98131C01.1	Chariot à fourches	Portador de horquilla
Front Counterweight Kit.....	98001C01.1	Coffret de Contrepoids Avant	Juego de contrapeso delantero
Front Fenders.....	63001C01.1	Ailes Avant	Alas delanteras
Front Fenders.....	63002C01.1	Ailes Avant	Alas delanteras
Fuel Strainer Kit.....	98071C01.1	Coffret de Crépine de Carburant	Juego de alcachofa de carburante
Grain/Snow Bucket.....	98132C01.1	Godet à grains/neige	Cuchara de grano/nieve
Guard Kit - Bonnet Grille	98126C01.1	Kit de protection - Grille de capot	Kit de protector – Parrilla del capó
Hose Burst Kit.....	98038C01.1	Coffret de Éclatement de Tuyau	Juego de rotura de tubo flexible
Hose Burst Kit.....	98038C02.1	Coffret de Éclatement de Tuyau	Juego de rotura de tubo flexible
Hose Burst Kit.....	98039C01.1	Coffret de Éclatement de Tuyau	Juego de rotura de tubo flexible
Hose Burst Kit.....	98039C02.1	Coffret de Éclatement de Tuyau	Juego de rotura de tubo flexible
Hose Burst Kit.....	98040C01.1	Coffret de Éclatement de Tuyau	Juego de rotura de tubo flexible
Hose Burst Kit.....	98040C02.1	Coffret de Éclatement de Tuyau	Juego de rotura de tubo flexible
Hose Burst Kit.....	98057C01.1	Coffret de Éclatement de Tuyau	Juego de rotura de tubo flexible
Hose Burst Kit.....	98057C02.1	Coffret de Éclatement de Tuyau	Juego de rotura de tubo flexible
Hose Burst Kit.....	98057C03.1	Coffret de Éclatement de Tuyau	Juego de rotura de tubo flexible
Hose Burst Kit.....	98057C04.1	Coffret de Éclatement de Tuyau	Juego de rotura de tubo flexible
Hose Burst Kit.....	98058C01.1	Coffret de Éclatement de Tuyau	Juego de rotura de tubo flexible
Hose Burst Kit.....	98058C02.1	Coffret de Éclatement de Tuyau	Juego de rotura de tubo flexible
Hose Burst Kit.....	98058C03.1	Coffret de Éclatement de Tuyau	Juego de rotura de tubo flexible
Hose Burst Kit.....	98058C04.1	Coffret de Éclatement de Tuyau	Juego de rotura de tubo flexible
JCB Bucket Pins Kit.....	98008C01.1	Coffret de Attaches de Godet JCB	Juego de pasadores cuchara JCB
JCB Bucket Pins Kit.....	98009C01.1	Coffret de Attaches de Godet JCB	Juego de pasadores cuchara JCB
Kit - Boom Guard.....	98186C01.1	Coffret	Juego
Kit - Engine Breather	98037C01.1	Coffret - Reniflard	Juego - Respiradero
Kit - Filter	98111C01.1	Coffret - Filtre	Juego - Filtro
Kit - Filter	98112C01.1	Coffret - Filtre	Juego - Filtro
Kit - Filter	98193C01.1	Coffret - Filtre	Juego - Filtro
Kit - Forks	94001AC01.1	Coffret - Fourchettes	Juego - Horquillas
Kit - Forks	94001C01.1	Coffret - Fourchettes	Juego - Horquillas
Kit - Forks	94002C01.1	Coffret - Fourchettes	Juego - Horquillas
Kit - Front Grille Protection	98188C01.1	Coffret - Protecteur	Juego - Protector
Kit - Headrest.....	98107AC01.1	Coffret - Repose Tete	Juego - Apoya Cabeza
Kit - Headrest.....	98107C01.1	Coffret - Repose Tete	Juego - Apoya Cabeza
Kit - Hydraulic Pipe Guard.....	98184C01.1	Coffret	Juego
Kit - Loader Quick Attach.....	94005C01.1	Coffret - Attache Rapide Pour Chargeur	Juego - Acoplamiento rápido cargadora



A - Accessories • Accessoires • Accesorios

Kit - Loader Quick Attach Tubes.....	94004C01.1	Coffret - Tubes d'attache Rapide pour Chargeur	Juego - Tubos de acoplamiento rápido cargadora
Licence Plate.....	95011C01.1	Plaque Minéralogique	Placa de matrícula
Pre Cleaner Kit.....	98108C01.1	Coffret de Filtre à Air	Juego de filtros
Quick Attach, Loader.....	94005C02.1	Accouplement Rapide, Chargeur	Acoplamiento rápido, cargadora
Reverse Alarm.....	95025C01.1	Alarme de Marche Arrière	Alarma de marcha trasera
Ride Control - Hydraulic Circuit.....	64001C01.1	Circuit Hydraulique - Système Anti-Tangage	Control anticabeceo - Circuito hidráulico
Ride Control - Hydraulic Circuit.....	64001C02.1	Circuit Hydraulique - Système Anti-Tangage	Control anticabeceo - Circuito hidráulico
Ride Control - Hydraulic Circuit.....	64002C01.1	Circuit Hydraulique - Système Anti-Tangage	Control anticabeceo - Circuito hidráulico
Ride Control - Hydraulic Circuit.....	64004C01.1	Circuit Hydraulique - Système Anti-Tangage	Control anticabeceo - Circuito hidráulico
Ride Control - Hydraulic Circuit.....	64004C02.1	Circuit Hydraulique - Système Anti-Tangage	Control anticabeceo - Circuito hidráulico
Ride Control - Hydraulic Circuit.....	64005C01.1	Circuit Hydraulique - Système Anti-Tangage	Control anticabeceo - Circuito hidráulico
Ride Control - Hydraulic Circuit.....	64005C02.1	Circuit Hydraulique - Système Anti-Tangage	Control anticabeceo - Circuito hidráulico
Ride Control - Hydraulic Circuit.....	64006C01.1	Circuit Hydraulique - Système Anti-Tangage	Control anticabeceo - Circuito hidráulico
Ride Control - Hydraulic Circuit.....	64006C02.1	Circuit Hydraulique - Système Anti-Tangage	Control anticabeceo - Circuito hidráulico
Ride Control - Hydraulic Circuit.....	64007C01.1	Circuit Hydraulique - Système Anti-Tangage	Control anticabeceo - Circuito hidráulico
Ride Control - Hydraulic Circuit.....	64007C02.1	Circuit Hydraulique - Système Anti-Tangage	Control anticabeceo - Circuito hidráulico
Ride Control - Hydraulic Circuit.....	64008C01.1	Circuit Hydraulique - Système Anti-Tangage	Control anticabeceo - Circuito hidráulico
Ride Control - Hydraulic Circuit.....	64008C02.1	Circuit Hydraulique - Système Anti-Tangage	Control anticabeceo - Circuito hidráulico
Ride Control - Hydraulic Circuit.....	64009C01.1	Circuit Hydraulique - Système Anti-Tangage	Control anticabeceo - Circuito hidráulico
Ride Control - Hydraulic Circuit.....	64009C02.1	Circuit Hydraulique - Système Anti-Tangage	Control anticabeceo - Circuito hidráulico
Ride Control - Hydraulic Circuit.....	98036C01.1	Circuit Hydraulique - Système Anti-Tangage	Control anticabeceo - Circuito hidráulico
Ride Control - Hydraulic Circuit.....	98130AC01.1	Circuit Hydraulique - Système Anti-Tangage	Control anticabeceo - Circuito hidráulico
Ride Control - Hydraulic Circuit.....	98130C01.1	Circuit Hydraulique - Système Anti-Tangage	Control anticabeceo - Circuito hidráulico
Rockguard Kit.....	98104C01.1	Coffret de Protection Vérin de Stabilisateur	Juego de protección de gato de estabilizador
Rotating Beacon Kit.....	98015AC01.1	Coffret de Feu Intermittent	Juego de luz giratoria
Rotating Beacon Kit.....	98015C01.1	Coffret de Feu Intermittent	Juego de luz giratoria
Rotating Beacon Kit.....	98016AC01.1	Coffret de Feu Intermittent	Juego de luz giratoria
Rotating Beacon Kit.....	98016C01.1	Coffret de Feu Intermittent	Juego de luz giratoria
Seat Armrest Kit.....	98017AC01.1	Coffret de Accoudoir de Siège	Juego de apoyabrazos de asiento
Seat Armrest Kit.....	98017C01.1	Coffret de Accoudoir de Siège	Juego de apoyabrazos de asiento
Seat Belt Kit.....	95022C01.1	Coffret de Ceinture de Siège	Juego de cinturón de asiento
Service Tool Kit.....	98019C01.1	Coffret de Outillage d'entretien	Juego de herramientas de servicio
Service Tool Kit.....	98109C01.1	Coffret de Outillage d'entretien	Juego de herramientas de servicio
Spare Wheels - Front (M03 & M10).....	98139C01.1		
Spare Wheels - Front (M03 & M10).....	98150C01.1		
Spare Wheels - Front (M04).....	98140C01.1		
Spare Wheels - Front (M04).....	98151C01.1		
Spare Wheels - Front (M09).....	98143C01.1		



A - Accessories • Accessoires • Accesorios

Spare Wheels - Front (M09).....	98154C01.1		
Spare Wheels - Front (M20 & M22).....	98147C01.1		
Spare Wheels - Front (M20 & M22).....	98158C01.1		
Spare Wheels - Front (M21).....	98148C01.1		
Spare Wheels - Front (M21).....	98159C01.1		
Spare Wheels - Rear (M01 & M04).....	98165C01.1		
Spare Wheels - Rear (M01 & M04).....	98177C01.1		
Spare Wheels - Rear (M03 & M13).....	98164C01.1		
Spare Wheels - Rear (M03 & M13).....	98176C01.1		
Spare Wheels - Rear (M05, M09, M14 & M21).....	98162C01.1		
Spare Wheels - Rear (M05, M09, M14 & M21).....	98174C01.1		
Spare Wheels - Rear (M07, M10 & M12).....	98161C01.1		
Spare Wheels - Rear (M07, M10 & M12).....	98173C01.1		
Spare Wheels - Rear (M15).....	98166C01.1		
Spare Wheels - Rear (M15).....	98178C01.1		
Spare Wheels - Rear (M16).....	98167C01.1		
Spare Wheels - Rear (M16).....	98179C01.1		
Spare Wheels - Rear (M17).....	98168C01.1		
Spare Wheels - Rear (M20).....	98170C01.1		
Spare Wheels - Rear (M22).....	98171C01.1		
Spare Wheels - Rear (M22).....	98183C01.1		
Steering Wheel Spinner Knob Kit.....	98014AC01.1	Coffret de Poignée de Manœuvre Volant	Juego de asa de maniobra de volante
Steering Wheel Spinner Knob Kit.....	98014C01.1	Coffret de Poignée de Manœuvre Volant	Juego de asa de maniobra de volante
Street Pads Kit.....	98110C01.1	Coffret de Plaquettes Route	Juego de plataformas de calle
Sunvisor Kit.....	98018C01.1	Coffret de Visière	Juego de visera
Tool Kit - Wheel Brace + Grease Gun.....	89001C01.1	Outillage - Clé à Roues - Clé à Roues - Pompe à Graisse	Herramienta - Llave de ruedas + engrasador
Tooth Guard Kit - With decal.....	95001C01.1	Coffret de Protège-Dent - Avec adhésif	Juego de protección de dientes - Con adhesivo
Tooth Guard Kit - With decal.....	95003C01.1	Coffret de Protège-Dent - Avec adhésif	Juego de protección de dientes - Con adhesivo
Tooth Guard Kit - With decal.....	95005C01.1	Coffret de Protège-Dent - Avec adhésif	Juego de protección de dientes - Con adhesivo
Tooth Guard Kit - With decal.....	95007C01.1	Coffret de Protège-Dent - Avec adhésif	Juego de protección de dientes - Con adhesivo
Tooth Guard Kit - Without Decal.....	95002C01.1	Coffret de Protège-Dent - Sans adhésif	Juego de protección de dientes - Sin adhesivo
Tooth Guard Kit - Without Decal.....	95004C01.1	Coffret de Protège-Dent - Sans adhésif	Juego de protección de dientes - Sin adhesivo
Tooth Guard Kit - Without Decal.....	95006C01.1	Coffret de Protège-Dent - Sans adhésif	Juego de protección de dientes - Sin adhesivo
Tooth Guard Kit - Without Decal.....	95008C01.1	Coffret de Protège-Dent - Sans adhésif	Juego de protección de dientes - Sin adhesivo
Transport Height Decal Kit.....	95009C01.1	Coffret de Adhésif Hauteur	Juego de altura adhesivo
Worklight Kit.....	98105C01.1	Coffret de Feu de Travail	Juego de faro de trabajo
Worklight Kit.....	98185C01.1	Coffret de Feu de Travail	Juego de faro de trabajo



Auxiliary Hydraulics
Hydraulique Auxiliaire
Circuito hidráulico auxiliar

Centremount
Montage de Pelle Central
Excavadora de montaje central

Telescopic Dipper - Boom 4.5m
Balancier Téléscopique - Flèche 4.5m
Balancín telescópico - Pluma 4.5m

Cab
 Cab
 Cab

C-98075-01.1-A

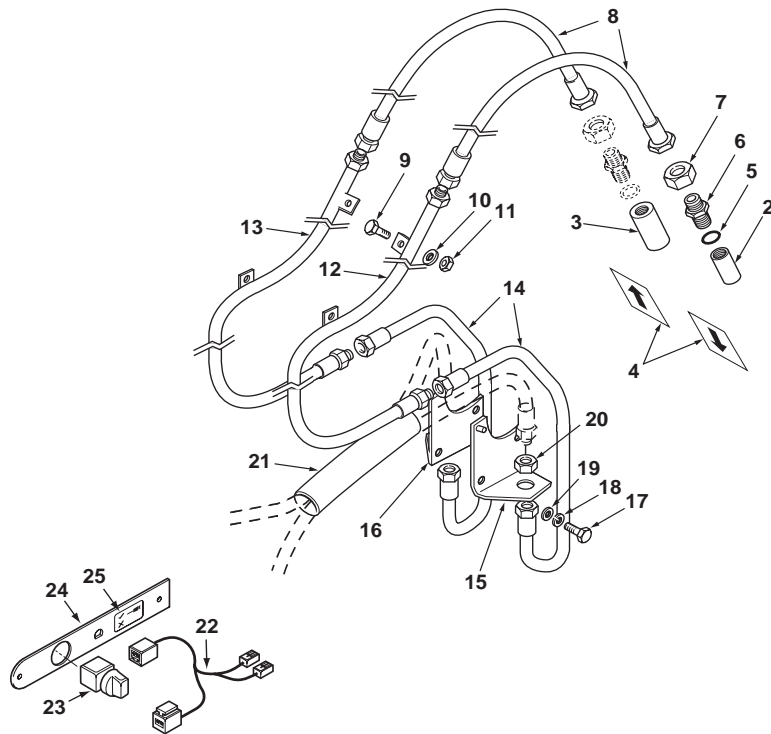

1	6110187M91		4.5 CM Aux with Extendahoe	1	Kit, Installation	Colis d'installation	Juego de instalación
2	3516796M91	1	Male	1	Coupler, Quick	Coupleur rapide	Acoplador rápido
3	3516797M91	1	Female	1	Coupler, Quick	Coupleur rapide	Acoplador rápido
4	6106080M1	1	Arrow	2	Decal	Adhésif	Adhesivo
5	835025M1	1		2	O-Ring	Joint torique	Junta de tipo O
6	356269X1	1		2	Connector, Bulkhead	Passe-cloison	Pasatabiques
7	355575X1	1		2	Nut, Lock	Écrou de blocage	Tuerca de retención
8	6106190M91	1		2	Hose Assy	Ensemble de flexible	Flexible, Conj.
9	339761X1	1	M8 x 25	4	Screw	Vis	Tornillo
10	390972X1	1	M8	4	Washer	Rondelle	Arandela
11	394367X1	1	M8	4	Nut, Lock	Écrou de blocage	Tuerca de retención
12	6106186M91	1	◀	1	Tube Assy	Tuyauterie	Conjunto de tubería
13	6106188M91	1	▶	1	Tube Assy	Tuyauterie	Conjunto de tubería
14	6106746M91	1		2	Hose Assy	Ensemble de flexible	Flexible, Conj.
15	3517380M93	1	◀	1	Bracket Assy	Ensemble chaise palier	Cuchara, Conj.
16	3517379M2	1	▶	1	Bracket	Patte de fixation	Pata de fijación
17	339123X1	1	M8 x 20	4	Bolt	Boulon	Perno
18	339374X1	1	M8	4	Washer, Lock	Rondelle de blocage	Arandela de freno
19	390972X1	1	M8	4	Washer	Rondelle	Arandela
20	355575X1	1		2	Nut, Lock	Écrou de blocage	Tuerca de retención
21	6106082M1	1		1	Sleeve	Chemise	Camisa
22	6107467M92	1		1	Harness Assy	Ensemble de faisceau	Haz, Conj.
23	6107165M91	1		1	Switch Assy	Ensemble commutat.	Conmutador, Conj.
24	6107176M2	1		1	Plate	Plaque	Placa
25	6108710M1	1		1	Decal	Adhésif	Adhesivo



820 860 880
 TX760B TX860B

801 803 809 813 821 831 841 851

98075C01.1

6199042M3

1

Jan-06

Auxiliary Hydraulics
Hydraulique Auxiliaire
Circuito hidráulico auxiliar

Centremount
Montage de Pelle Central
Excavadora de montaje central

Telescopic Dipper - Boom 4.5m
Balancier Télésopique - Flèche 4.5m
Balancín telescópico - Pluma 4.5m

Cab
 Cab
 Cab

C-98075-02.1-A

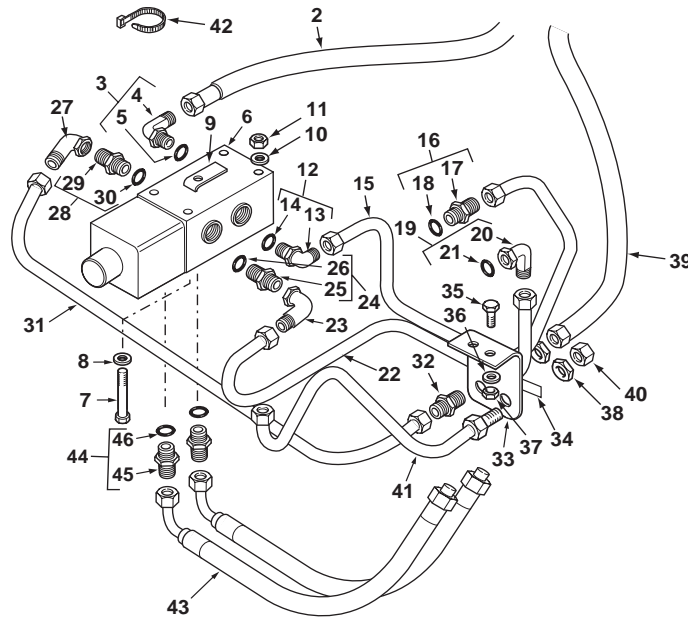

1	6110187M91		Continued 4.5 CM Aux with Extendahoe	1	Kit, Installation	Colis d'installation	Juego de instalación
2	6107468M92	1		1	Hose Assy	Ensemble de flexible	Flexible, Conj.
3	358764X91	1		1	Elbow, 90°	Coude à 90°	Codo, 90°
4		3	➡ Ref. 3	1	Elbow	Coude	Codo
5	835025M1	3		1	O-Ring	Joint torique	Junta de tipo O
6	6108292M91	1		1	Valve, Priority	Soupape de priorité	Válvula de prioridad
7	3019894X1	1	M6 x 100	3	Screw	Vis	Tornillo
8	391038X1	1	M6	3	Washer	Rondelle	Arandela
9	6108445M1	1		1	Bracket	Patte de fixation	Pata de fijación
10	390971X1	1	M6	3	Washer	Rondelle	Arandela
11	1441500X1	1	M6	3	Nut, Lock	Écrou de blocage	Tuerca de retención
12	358764X91	1		1	Elbow, 90°	Coude à 90°	Codo, 90°
13		12	➡ Ref. 12	1	Elbow	Coude	Codo
14	835025M1	12		1	O-Ring	Joint torique	Junta de tipo O
15	6109620M91	1		1	Tube Assy	Tuyauterie	Conjunto de tubería
16	835057M91	1		1	Connector Assy	Ensemble connexion	Conexión, Conj.
17		16	➡ Ref. 16	1	Connector	Connecteur	Conector
18	835025M1	16		1	O-Ring	Joint torique	Junta de tipo O
19	358764X91	1		1	Elbow, 90°	Coude à 90°	Codo, 90°
20		19	➡ Ref. 19	1	Elbow	Coude	Codo
21	835025M1	19		1	O-Ring	Joint torique	Junta de tipo O
22	6109622M91	1		1	Tube Assy	Tuyauterie	Conjunto de tubería
23	366462X1	1		1	Elbow, 90°	Coude à 90°	Codo, 90°
24	835057M91	1		1	Connector Assy	Ensemble connexion	Conexión, Conj.
25		24	➡ Ref. 24	1	Connector	Connecteur	Conector
26	835025M1	24		1	O-Ring	Joint torique	Junta de tipo O
27	366462X1	1		1	Elbow, 90°	Coude à 90°	Codo, 90°
28	835057M91	1		1	Connector Assy	Ensemble connexion	Conexión, Conj.
29		28	➡ Ref. 28	1	Connector	Connecteur	Conector
30	835025M1	28		1	O-Ring	Joint torique	Junta de tipo O
31	6109766M91	1		1	Tube Assy	Tuyauterie	Conjunto de tubería
32	356269X1	1		1	Connector, Bulkhead	Passe-cloison	Pasatabiques
33	6109769M1	1		1	Bracket	Patte de fixation	Pata de fijación
34	6109770M1	1		1	Decal	Adhésif	Adhesivo
35	339804X1	1	M6 x 25	2	Screw	Vis	Tornillo
36	390971X1	1	M6	2	Washer	Rondelle	Arandela
37	1441500X1	1	M6	2	Nut, Lock	Écrou de blocage	Tuerca de retención
38	355575X1	1		2	Nut, Lock	Écrou de blocage	Tuerca de retención
39	6109768M91	1		1	Hose Assy	Ensemble de flexible	Flexible, Conj.
40	355782X1	1		1	Plug, Blank-Off	Obturateur	Obturador
41	6110023M91	1		1	Tube Assy	Tuyauterie	Conjunto de tubería
42	1862425M1	1		6	Tie, Cable	Attache câble	Enlace de Cable
43	6109552M91	1		2	Hose Assy	Ensemble de flexible	Flexible, Conj.



820 860 880
 TX760B TX860B

801 803 809 813 821 831 841 851

98075C02.1

6199042M3

1

Jan-06

Auxiliary Hydraulics
Hydraulique Auxiliaire
Circuito hidráulico auxiliar

Centremount
Montage de Pelle Central
Excavadora de montaje central

Telescopic Dipper - Boom 4.5m
 Balancier Téléscopique - Flèche 4.5m
 Balancín telescópico - Pluma 4.5m

Cab
 Cab
 Cab

C-98075-02.1-A

44	365715X91	1	1,1/16" - 7/8" UNF	2	Connector Assy	Ensemble connexion	Conexión, Conj.
45		44	 Ref. 44	1	Connector	Connecteur	Conector
46	835025M1	44		1	O-Ring	Joint torique	Junta de tipo O

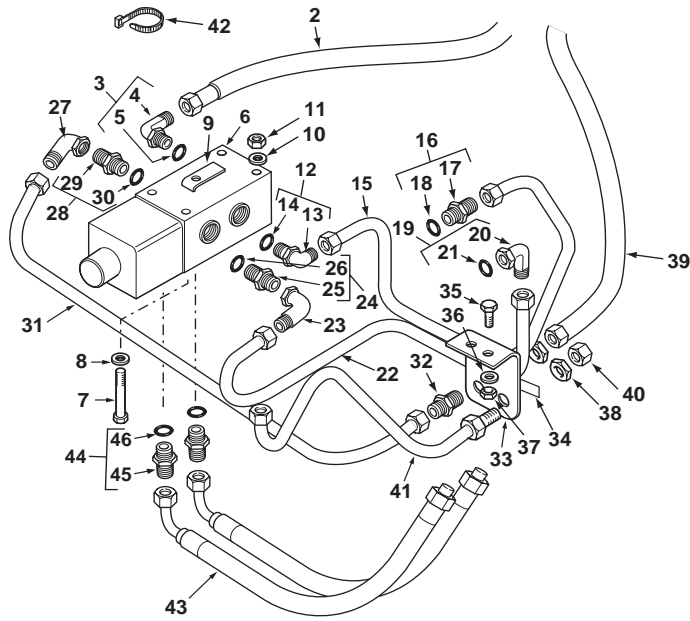

820 860 880
 TX760B TX860B

801 803 809 813 821 831 841 851

Auxiliary Hydraulics
Hydraulique Auxiliaire
Circuito hidráulico auxiliar

Centremount
Montage de Pelle Central
Excavadora de montaje central

Telescopic Dipper - Boom 4.9m
Balancier Téléscopique - Flèche 4.9m
Balancín telescópico - Pluma 4.9m

Cab
 Cab
 Cab

AC-98076-01.1-A

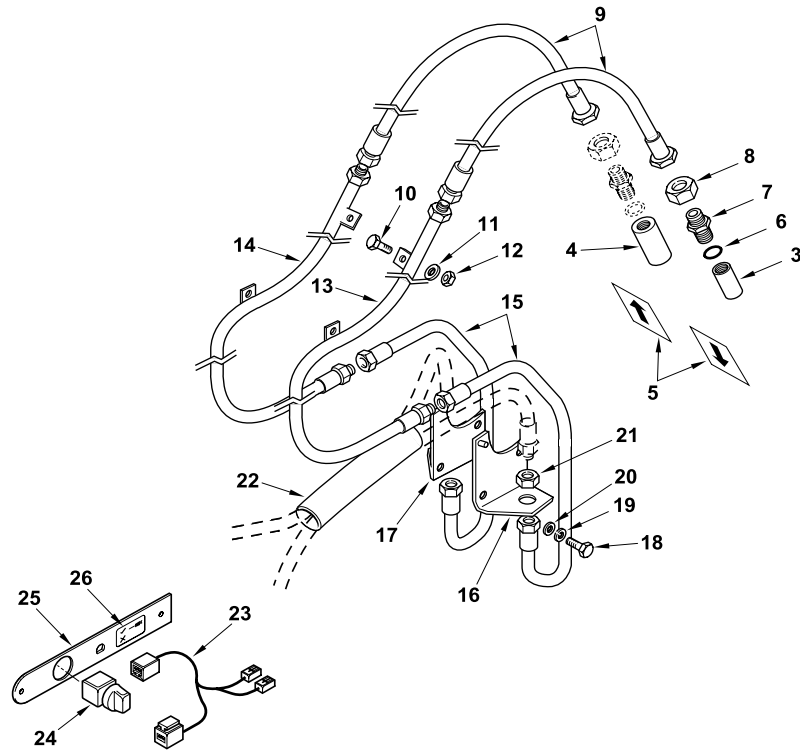

1	ACC81E			1	Accessory code	Code accessoire	Código accesorio
2	6110188M91	1	4.9 CM Aux with Extendahoe	1	Kit, Installation	Colis d'installation	Juego de instalación
3	3516796M91	2	Male	1	Coupler, Quick	Coupleur rapide	Acoplador rápido
4	3516797M91	2	Female	1	Coupler, Quick	Coupleur rapide	Acoplador rápido
5	6106080M1	2	Arrow	2	Decal	Adhésif	Adhesivo
6	835025M1	2		2	O-Ring	Joint torique	Junta de tipo O
7	356269X1	2		2	Connector, Bulkhead	Passe-cloison	Pasatabiques
8	355575X1	2		2	Nut, Lock	Écrou de blocage	Tuerca de retención
9	6106190M91	2		2	Hose Assy	Ensemble de flexible	Flexible, Conj.
10	339761X1	2	M8 x 25	4	Screw	Vis	Tornillo
11	390972X1	2	M8	4	Washer	Rondelle	Arandela
12	394367X1	2	M8	4	Nut, Lock	Écrou de blocage	Tuerca de retención
13	6106234M91	2	◀	1	Tube Assy	Tuyauterie	Conjunto de tubería
14	6106236M91	2	▶	1	Tube Assy	Tuyauterie	Conjunto de tubería
15	6106746M91	2		2	Hose Assy	Ensemble de flexible	Flexible, Conj.
16	3517380M93	2	◀	1	Bracket Assy	Ensemble chaise palier	Cuchara, Conj.
17	3517379M2	2	▶	1	Bracket	Patte de fixation	Pata de fijación
18	339123X1	2	M8 x 20	4	Bolt	Boulon	Perno
19	339374X1	2	M8	4	Washer, Lock	Rondelle de blocage	Arandela de freno
20	390972X1	2	M8	4	Washer	Rondelle	Arandela
21	355575X1	2		2	Nut, Lock	Écrou de blocage	Tuerca de retención
22	6106082M1	2		1	Sleeve	Chemise	Camisa
23	6107467M92	2		1	Harness Assy	Ensemble de faisceau	Haz, Conj.
24	6107165M91	2		1	Switch Assy	Ensemble commutat.	Conmutador, Conj.
25	6107176M2	2		1	Plate	Plaque	Placa
26	6108710M1	2		1	Decal	Adhésif	Adhesivo



860 880
 TX870B

811 815 823 843 853

98076AC01.1

6199042M3

1

Jan-06

Auxiliary Hydraulics
Hydraulique Auxiliaire
Circuito hidráulico auxiliar

Centremount
Montage de Pelle Central
Excavadora de montaje central

Telescopic Dipper - Boom 4.9m
Balancier Télescopique - Flèche 4.9m
Balancín telescópico - Pluma 4.9m

Cab
 Cab
 Cab

AC-98076-02.1-A

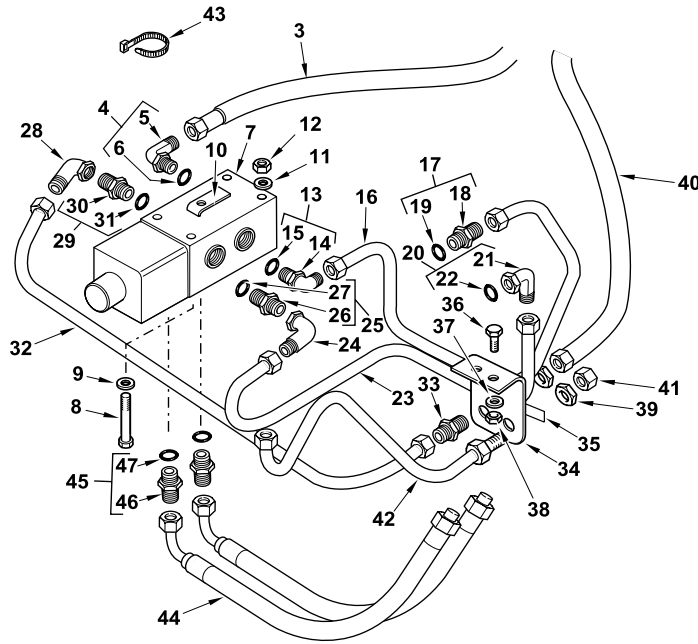

1	ACC81E		Continued	1	Accessory code	Code accessoire	Código accesorio
2	6110188M91	1	Continued 4.9 CM Aux with Extendahoe	1	Kit, Installation	Colis d'installation	Juego de instalación
3	6107468M92	2		1	Hose Assy	Ensemble de flexible	Flexible, Conj.
4	358764X91	2		1	Elbow, 90°	Coude à 90°	Codo, 90°
5		4	➡ Ref. 4	1	Elbow	Coude	Codo
6	835025M1	4		1	O-Ring	Joint torique	Junta de tipo O
7	6108292M91	2		1	Valve, Priority	Soupape de priorité	Válvula de prioridad
8	3019894X1	2	M6 x 100	3	Screw	Vis	Tornillo
9	391038X1	2	M6	3	Washer	Rondelle	Arandela
10	6108445M1	2		1	Bracket	Patte de fixation	Pata de fijación
11	390971X1	2	M6	3	Washer	Rondelle	Arandela
12	1441500X1	2	M6	3	Nut, Lock	Écrou de blocage	Tuerca de retención
13	358764X91	2		1	Elbow, 90°	Coude à 90°	Codo, 90°
14		13	➡ Ref. 13	1	Elbow	Coude	Codo
15	835025M1	13		1	O-Ring	Joint torique	Junta de tipo O
16	6109620M91	2		1	Tube Assy	Tuyauterie	Conjunto de tubería
17	835057M91	2		1	Connector Assy	Ensemble connexion	Conexión, Conj.
18		17	➡ Ref. 17	1	Connector	Connecteur	Conector
19	835025M1	17		1	O-Ring	Joint torique	Junta de tipo O
20	358764X91	2		1	Elbow, 90°	Coude à 90°	Codo, 90°
21		20	➡ Ref. 20	1	Elbow	Coude	Codo
22	835025M1	20		1	O-Ring	Joint torique	Junta de tipo O
23	6109622M91	2		1	Tube Assy	Tuyauterie	Conjunto de tubería
24	366462X1	2		1	Elbow, 90°	Coude à 90°	Codo, 90°
25	835057M91	2		1	Connector Assy	Ensemble connexion	Conexión, Conj.
26		25	➡ Ref. 25	1	Connector	Connecteur	Conector
27	835025M1	25		1	O-Ring	Joint torique	Junta de tipo O
28	366462X1	2		1	Elbow, 90°	Coude à 90°	Codo, 90°
29	835057M91	2		1	Connector Assy	Ensemble connexion	Conexión, Conj.
30		29	➡ Ref. 29	1	Connector	Connecteur	Conector
31	835025M1	29		1	O-Ring	Joint torique	Junta de tipo O
32	6109766M91	2		1	Tube Assy	Tuyauterie	Conjunto de tubería
33	356269X1	2		1	Connector, Bulkhead	Passe-cloison	Pasatabiques
34	6109769M1	2		1	Bracket	Patte de fixation	Pata de fijación
35	6109770M1	2		1	Decal	Adhésif	Adhesivo
36	339804X1	2	M6 x 25	2	Screw	Vis	Tornillo
37	390971X1	2	M6	2	Washer	Rondelle	Arandela
38	1441500X1	2	M6	2	Nut, Lock	Écrou de blocage	Tuerca de retención
39	355575X1	2		2	Nut, Lock	Écrou de blocage	Tuerca de retención
40	6109768M91	2		1	Hose Assy	Ensemble de flexible	Flexible, Conj.
41	355782X1	2		1	Plug, Blank-Off	Obturateur	Obturador
42	6110023M91	2		1	Tube Assy	Tuyauterie	Conjunto de tubería
43	1862425M1	2		6	Tie, Cable	Attache câble	Enlace de Cable



860 880
 TX870B

811 815 823 843 853

98076AC02.1

6199042M3

1

Jan-06

Auxiliary Hydraulics
Hydraulique Auxiliaire
Circuito hidráulico auxiliar

Centremount
Montage de Pelle Central
Excavadora de montaje central

Telescopic Dipper - Boom 4.9m
 Balancier Téléscopique - Flèche 4.9m
 Balancín telescópico - Pluma 4.9m

Cab
 Cab
 Cab

AC-98076-02.1-A

44	6109552M91	2		2	Hose Assy	Ensemble de flexible	Flexible, Conj.
45	365715X91	2	1,1/16" - 7/8" UNF	2	Connector Assy	Ensemble connexion	Conexión, Conj.
46		45	 Ref. 45	1	Connector	Connecteur	Conector
47	835025M1	45		1	O-Ring	Joint torique	Junta de tipo O

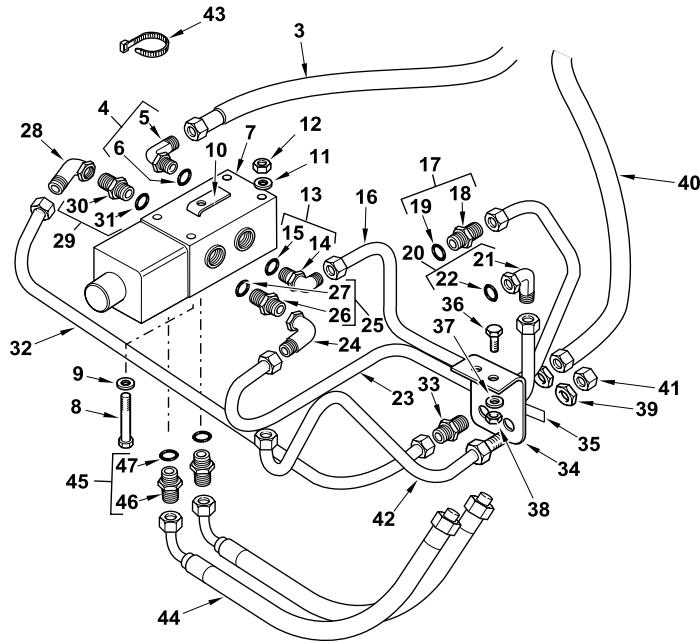

860 880
 TX870B

811 815 823 843 853

98076AC02.1

6199042M3

1

Jan-06

Auxiliary Hydraulics
Hydraulique Auxiliaire
Circuito hidráulico auxiliar

Centremount
Montage de Pelle Central
Excavadora de montaje central

Telescopic Dipper - Boom 4.9m
Balancier Téléscopique - Flèche 4.9m
Balancín telescópico - Pluma 4.9m

Cab
 Cab
 Cab

C-98076-01.1-A

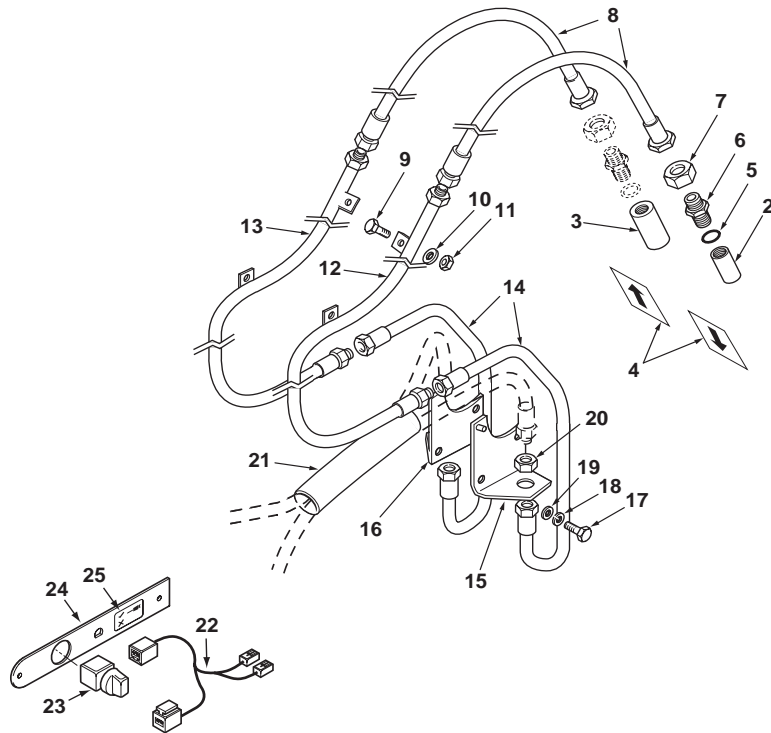

1	6110188M91		4.9 CM Aux with Extendahoe	1	Kit, Installation	Colis d'installation	Juego de instalación
2	3516796M91	1	Male	1	Coupler, Quick	Coupleur rapide	Acoplador rápido
3	3516797M91	1	Female	1	Coupler, Quick	Coupleur rapide	Acoplador rápido
4	6106080M1	1	Arrow	2	Decal	Adhésif	Adhesivo
5	835025M1	1		2	O-Ring	Joint torique	Junta de tipo O
6	356269X1	1		2	Connector, Bulkhead	Passe-cloison	Pasatabiques
7	355575X1	1		2	Nut, Lock	Écrou de blocage	Tuerca de retención
8	6106190M91	1		2	Hose Assy	Ensemble de flexible	Flexible, Conj.
9	339761X1	1	M8 x 25	4	Screw	Vis	Tornillo
10	390972X1	1	M8	4	Washer	Rondelle	Arandela
11	394367X1	1	M8	4	Nut, Lock	Écrou de blocage	Tuerca de retención
12	6106234M91	1	◀	1	Tube Assy	Tuyauterie	Conjunto de tubería
13	6106236M91	1	▶	1	Tube Assy	Tuyauterie	Conjunto de tubería
14	6106746M91	1		2	Hose Assy	Ensemble de flexible	Flexible, Conj.
15	3517380M93	1	◀	1	Bracket Assy	Ensemble chaise palier	Cuchara, Conj.
16	3517379M2	1	▶	1	Bracket	Patte de fixation	Pata de fijación
17	339123X1	1	M8 x 20	4	Bolt	Boulon	Perno
18	339374X1	1	M8	4	Washer, Lock	Rondelle de blocage	Arandela de freno
19	390972X1	1	M8	4	Washer	Rondelle	Arandela
20	355575X1	1		2	Nut, Lock	Écrou de blocage	Tuerca de retención
21	6106082M1	1		1	Sleeve	Chemise	Camisa
22	6107467M92	1		1	Harness Assy	Ensemble de faisceau	Haz, Conj.
23	6107165M91	1		1	Switch Assy	Ensemble commutat.	Conmutador, Conj.
24	6107176M2	1		1	Plate	Plaque	Placa
25	6108710M1	1		1	Decal	Adhésif	Adhesivo



860 880
 TX870B

811 815 823 843 853

98076C01.1

6199042M3

1

Jan-06

Auxiliary Hydraulics
Hydraulique Auxiliaire
Circuito hidráulico auxiliar

Centremount
Montage de Pelle Central
Excavadora de montaje central

Telescopic Dipper - Boom 4.9m
Balancier Téléscofique - Flèche 4.9m
Balancín telescópico - Pluma 4.9m

Cab
 Cab
 Cab

C-98076-02.1-A

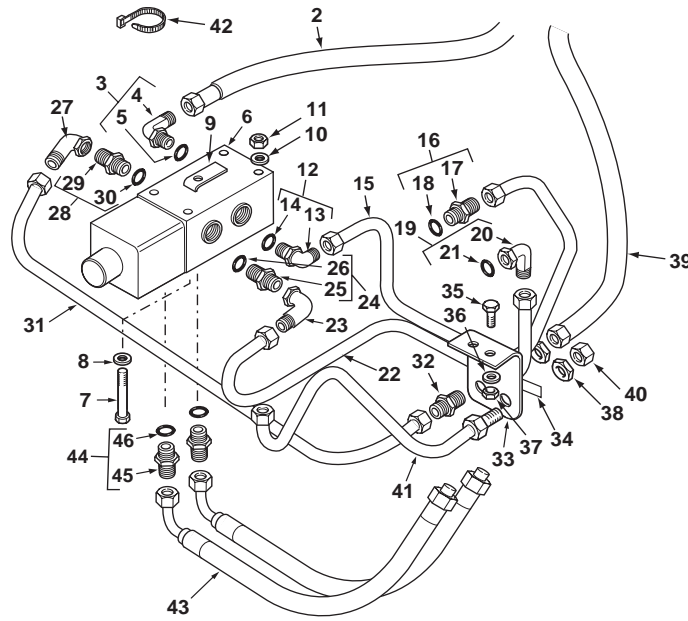

1	6110188M91		Continued 4.9 CM Aux with Extendahoe	1	Kit, Installation	Colis d'installation	Juego de instalación
2	6107468M92	1		1	Hose Assy	Ensemble de flexible	Flexible, Conj.
3	358764X91	1		1	Elbow, 90°	Coude à 90°	Codo, 90°
4		3	➡ Ref. 3	1	Elbow	Coude	Codo
5	835025M1	3		1	O-Ring	Joint torique	Junta de tipo O
6	6108292M91	1		1	Valve, Priority	Soupape de priorité	Válvula de prioridad
7	3019894X1	1	M6 x 100	3	Screw	Vis	Tornillo
8	391038X1	1	M6	3	Washer	Rondelle	Arandela
9	6108445M1	1		1	Bracket	Patte de fixation	Pata de fijación
10	390971X1	1	M6	3	Washer	Rondelle	Arandela
11	1441500X1	1	M6	3	Nut, Lock	Écrou de blocage	Tuerca de retención
12	358764X91	1		1	Elbow, 90°	Coude à 90°	Codo, 90°
13		12	➡ Ref. 12	1	Elbow	Coude	Codo
14	835025M1	12		1	O-Ring	Joint torique	Junta de tipo O
15	6109620M91	1		1	Tube Assy	Tuyauterie	Conjunto de tubería
16	835057M91	1		1	Connector Assy	Ensemble connexion	Conexión, Conj.
17		16	➡ Ref. 16	1	Connector	Connecteur	Conector
18	835025M1	16		1	O-Ring	Joint torique	Junta de tipo O
19	358764X91	1		1	Elbow, 90°	Coude à 90°	Codo, 90°
20		19	➡ Ref. 19	1	Elbow	Coude	Codo
21	835025M1	19		1	O-Ring	Joint torique	Junta de tipo O
22	6109622M91	1		1	Tube Assy	Tuyauterie	Conjunto de tubería
23	366462X1	1		1	Elbow, 90°	Coude à 90°	Codo, 90°
24	835057M91	1		1	Connector Assy	Ensemble connexion	Conexión, Conj.
25		24	➡ Ref. 24	1	Connector	Connecteur	Conector
26	835025M1	24		1	O-Ring	Joint torique	Junta de tipo O
27	366462X1	1		1	Elbow, 90°	Coude à 90°	Codo, 90°
28	835057M91	1		1	Connector Assy	Ensemble connexion	Conexión, Conj.
29		28	➡ Ref. 28	1	Connector	Connecteur	Conector
30	835025M1	28		1	O-Ring	Joint torique	Junta de tipo O
31	6109766M91	1		1	Tube Assy	Tuyauterie	Conjunto de tubería
32	356269X1	1		1	Connector, Bulkhead	Passe-cloison	Pasatabiques
33	6109769M1	1		1	Bracket	Patte de fixation	Pata de fijación
34	6109770M1	1		1	Decal	Adhésif	Adhesivo
35	339804X1	1	M6 x 25	2	Screw	Vis	Tornillo
36	390971X1	1	M6	2	Washer	Rondelle	Arandela
37	1441500X1	1	M6	2	Nut, Lock	Écrou de blocage	Tuerca de retención
38	355575X1	1		2	Nut, Lock	Écrou de blocage	Tuerca de retención
39	6109768M91	1		1	Hose Assy	Ensemble de flexible	Flexible, Conj.
40	355782X1	1		1	Plug, Blank-Off	Obturateur	Obturador
41	6110023M91	1		1	Tube Assy	Tuyauterie	Conjunto de tubería
42	1862425M1	1		6	Tie, Cable	Attache câble	Enlace de Cable
43	6109552M91	1		2	Hose Assy	Ensemble de flexible	Flexible, Conj.



860 880
 TX870B

811 815 823 843 853

98076C02.1

6199042M3

1

Jan-06

Auxiliary Hydraulics
Hydraulique Auxiliaire
Circuito hidráulico auxiliar

Centremount
Montage de Pelle Central
Excavadora de montaje central

Telescopic Dipper - Boom 4.9m
 Balancier Téléscopique - Flèche 4.9m
 Balancín telescópico - Pluma 4.9m

Cab
 Cab
 Cab

C-98076-02.1-A

44	365715X91	1	1,1/16" - 7/8" UNF	2	Connector Assy	Ensemble connexion	Conexión, Conj.
45		44	 Ref. 44	1	Connector	Connecteur	Conector
46	835025M1	44		1	O-Ring	Joint torique	Junta de tipo O

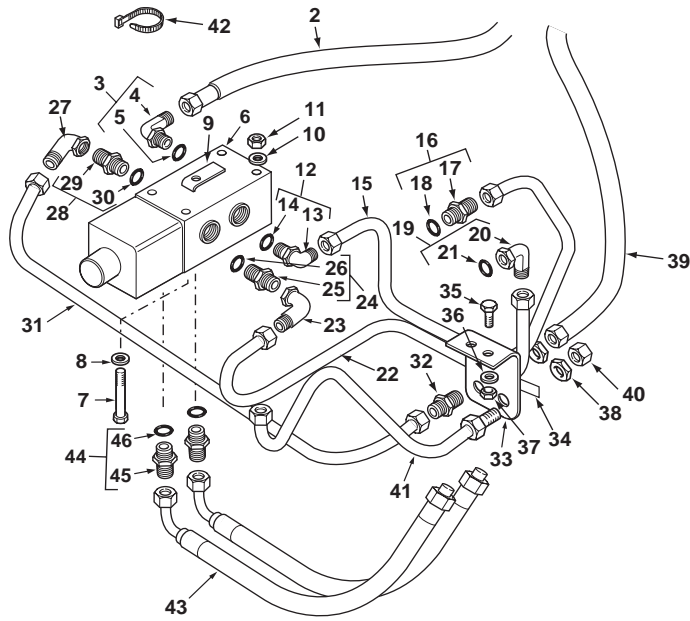

860 880
 TX870B

811 815 823 843 853

Auxiliary Hydraulics
Hydraulique Auxiliaire
Circuito hidráulico auxiliar

Centremount
Montage de Pelle Central
Excavadora de montaje central

Telescopic Dipper - Boom 4.5m
Balancier Téléscopique - Flèche 4.5m
Balancín telescópico - Pluma 4.5m

Rops
Rops
Rops

C-98077-01.1-A

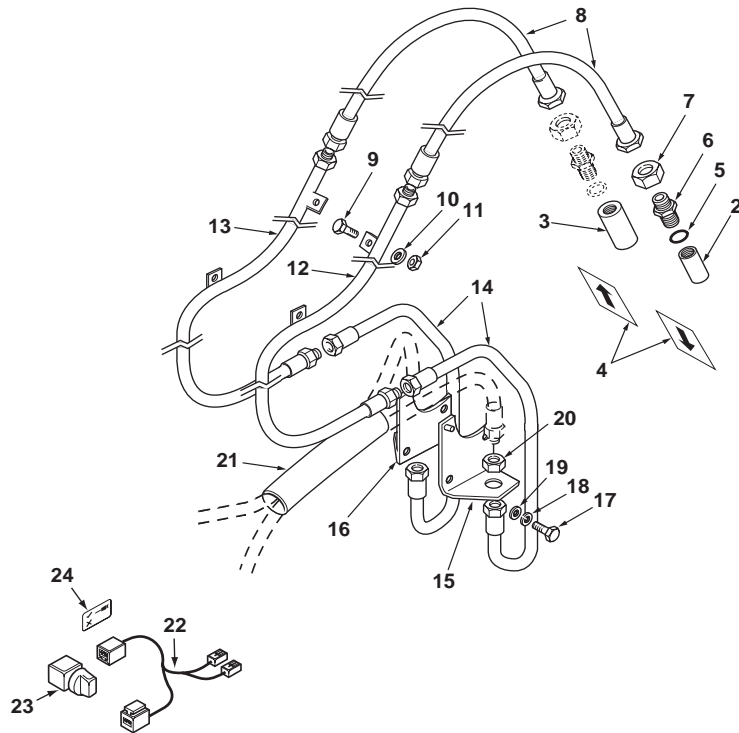

1	6110189M91		4.5 CM Aux with Extendahoe ROPS	1	Kit, Installation	Colis d'installation	Juego de instalación
2	3516796M91	1	Male	1	Coupler, Quick	Coupleur rapide	Acoplador rápido
3	3516797M91	1	Female	1	Coupler, Quick	Coupleur rapide	Acoplador rápido
4	6106080M1	1	Arrow	2	Decal	Adhésif	Adhesivo
5	835025M1	1		2	O-Ring	Joint torique	Junta de tipo O
6	356269X1	1		2	Connector, Bulkhead	Passe-cloison	Pasatabiques
7	355575X1	1		2	Nut, Lock	Écrou de blocage	Tuerca de retención
8	6106190M91	1		2	Hose Assy	Ensemble de flexible	Flexible, Conj.
9	339761X1	1	M8 x 25	4	Screw	Vis	Tornillo
10	390972X1	1	M8	4	Washer	Rondelle	Arandela
11	394367X1	1	M8	4	Nut, Lock	Écrou de blocage	Tuerca de retención
12	6106186M91	1	◀	1	Tube Assy	Tuyauterie	Conjunto de tubería
13	6106188M91	1	▶	1	Tube Assy	Tuyauterie	Conjunto de tubería
14	6106746M91	1		2	Hose Assy	Ensemble de flexible	Flexible, Conj.
15	3517380M93	1	◀	1	Bracket Assy	Ensemble chaise palier	Cuchara, Conj.
16	3517379M2	1	▶	1	Bracket	Patte de fixation	Pata de fijación
17	339123X1	1	M8 x 20	4	Bolt	Boulon	Perno
18	339374X1	1	M8	4	Washer, Lock	Rondelle de blocage	Arandela de freno
19	390972X1	1	M8	4	Washer	Rondelle	Arandela
20	355575X1	1		2	Nut, Lock	Écrou de blocage	Tuerca de retención
21	6106082M1	1		1	Sleeve	Chemise	Camisa
22	6107467M92	1		1	Harness Assy	Ensemble de faisceau	Haz, Conj.
23	6107165M91	1		1	Switch Assy	Ensemble commutat.	Conmutador, Conj.
24	6108710M1	1		1	Decal	Adhésif	Adhesivo



820 860 880
TX760B TX860B

802 804 810 814 822 832 842 852

98077C01.1

6199042M3

1

Jan-06

Auxiliary Hydraulics
Hydraulique Auxiliaire
Circuito hidráulico auxiliar

Centremount
Montage de Pelle Central
Excavadora de montaje central

Telescopic Dipper - Boom 4.5m
Balancier Téléscofique - Flèche 4.5m
Balancín telescópico - Pluma 4.5m

Rops
Rops
Rops

C-98077-02.1-A

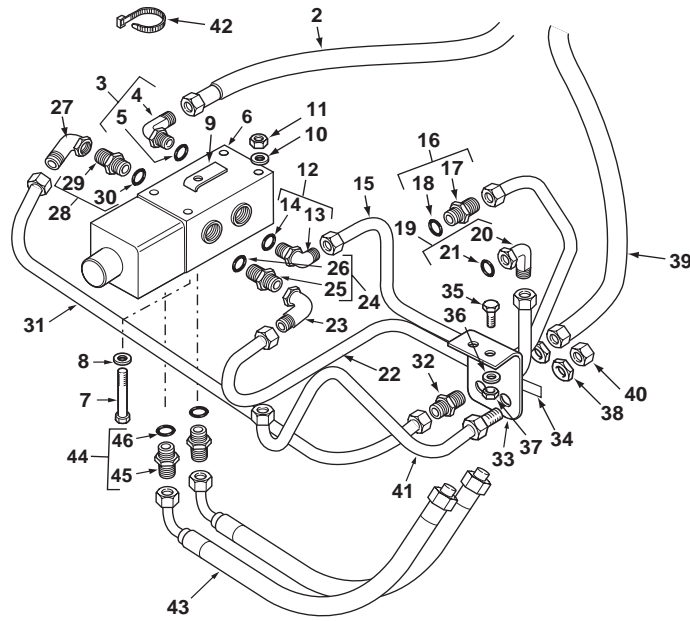

1	6110189M91		Continued 4.5 CM Aux with Extendahoe ROPS	1	Kit, Installation	Colis d'installation	Juego de instalación
2	6107468M92	1		1	Hose Assy	Ensemble de flexible	Flexible, Conj.
3	358764X91	1		1	Elbow, 90°	Coude à 90°	Codo, 90°
4		3	➡ Ref. 3	1	Elbow	Coude	Codo
5	835025M1	3		1	O-Ring	Joint torique	Junta de tipo O
6	6108292M91	1		1	Valve, Priority	Soupape de priorité	Válvula de prioridad
7	3019894X1	1	M6 x 100	3	Screw	Vis	Tornillo
8	391038X1	1	M6	3	Washer	Rondelle	Arandela
9	6108445M1	1		1	Bracket	Patte de fixation	Pata de fijación
10	390971X1	1	M6	3	Washer	Rondelle	Arandela
11	1441500X1	1	M6	3	Nut, Lock	Écrou de blocage	Tuerca de retención
12	358764X91	1		1	Elbow, 90°	Coude à 90°	Codo, 90°
13		12	➡ Ref. 12	1	Elbow	Coude	Codo
14	835025M1	12		1	O-Ring	Joint torique	Junta de tipo O
15	6109620M91	1		1	Tube Assy	Tuyauterie	Conjunto de tubería
16	835057M91	1		1	Connector Assy	Ensemble connexion	Conexión, Conj.
17		16	➡ Ref. 16	1	Connector	Connecteur	Conector
18	835025M1	16		1	O-Ring	Joint torique	Junta de tipo O
19	358764X91	1		1	Elbow, 90°	Coude à 90°	Codo, 90°
20		19	➡ Ref. 19	1	Elbow	Coude	Codo
21	835025M1	19		1	O-Ring	Joint torique	Junta de tipo O
22	6109622M91	1		1	Tube Assy	Tuyauterie	Conjunto de tubería
23	366462X1	1		1	Elbow, 90°	Coude à 90°	Codo, 90°
24	835057M91	1		1	Connector Assy	Ensemble connexion	Conexión, Conj.
25		24	➡ Ref. 24	1	Connector	Connecteur	Conector
26	835025M1	24		1	O-Ring	Joint torique	Junta de tipo O
27	366462X1	1		1	Elbow, 90°	Coude à 90°	Codo, 90°
28	835057M91	1		1	Connector Assy	Ensemble connexion	Conexión, Conj.
29		28	➡ Ref. 28	1	Connector	Connecteur	Conector
30	835025M1	28		1	O-Ring	Joint torique	Junta de tipo O
31	6109766M91	1		1	Tube Assy	Tuyauterie	Conjunto de tubería
32	356269X1	1		1	Connector, Bulkhead	Passe-cloison	Pasatabiques
33	6109769M1	1		1	Bracket	Patte de fixation	Pata de fijación
34	6109770M1	1		1	Decal	Adhésif	Adhesivo
35	339804X1	1	M6 x 25	2	Screw	Vis	Tornillo
36	390971X1	1	M6	2	Washer	Rondelle	Arandela
37	1441500X1	1	M6	2	Nut, Lock	Écrou de blocage	Tuerca de retención
38	355575X1	1		2	Nut, Lock	Écrou de blocage	Tuerca de retención
39	6109768M91	1		1	Hose Assy	Ensemble de flexible	Flexible, Conj.
40	355782X1	1		1	Plug, Blank-Off	Obturbateur	Obturador
41	6110023M91	1		1	Tube Assy	Tuyauterie	Conjunto de tubería
42	1862425M1	1		6	Tie, Cable	Attache câble	Enlace de Cable



820 860 880
TX760B TX860B

802 804 810 814 822 832 842 852

98077C02.1

6199042M3

1

Jan-06

Auxiliary Hydraulics
Hydraulique Auxiliaire
Circuito hidráulico auxiliar

Centremount
Montage de Pelle Central
Excavadora de montaje central

Telescopic Dipper - Boom 4.5m
Balancier Téléscopique - Flèche 4.5m
Balancín telescópico - Pluma 4.5m

Rops
Rops
Rops

C-98077-02.1-A

43	6109552M91	1		2	Hose Assy	Ensemble de flexible	Flexible, Conj.
44	365715X91	1	1,1/16" - 7/8" UNF	2	Connector Assy	Ensemble connexion	Conexión, Conj.
45		44	➡ Ref. 44	1	Connector	Connecteur	Conector
46	835025M1	44		1	O-Ring	Joint torique	Junta de tipo O

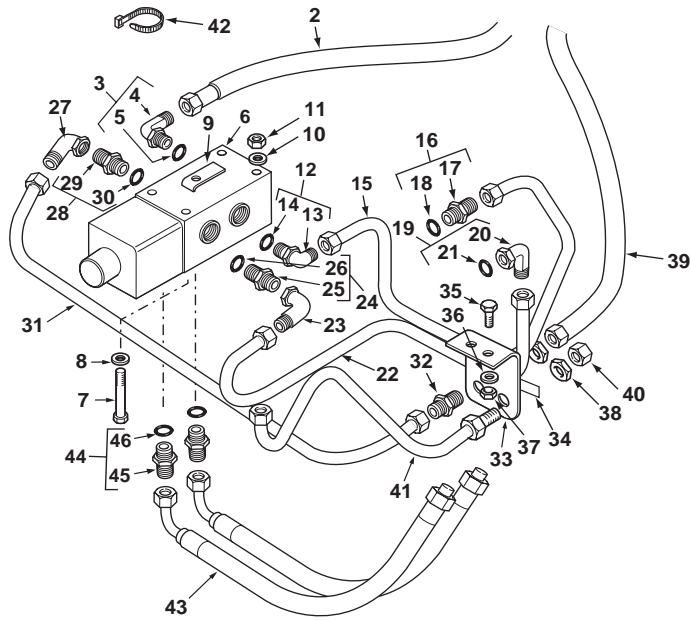

820 860 880
TX760B TX860B

802 804 810 814 822 832 842 852

Auxiliary Hydraulics
Hydraulique Auxiliaire
Circuito hidráulico auxiliar

Centremount
Montage de Pelle Central
Excavadora de montaje central

Telescopic Dipper - Boom 4.9m
Balancier Téléscopique - Flèche 4.9m
Balancín telescópico - Pluma 4.9m

Rops
Rops
Rops

C-98078-01.1-A

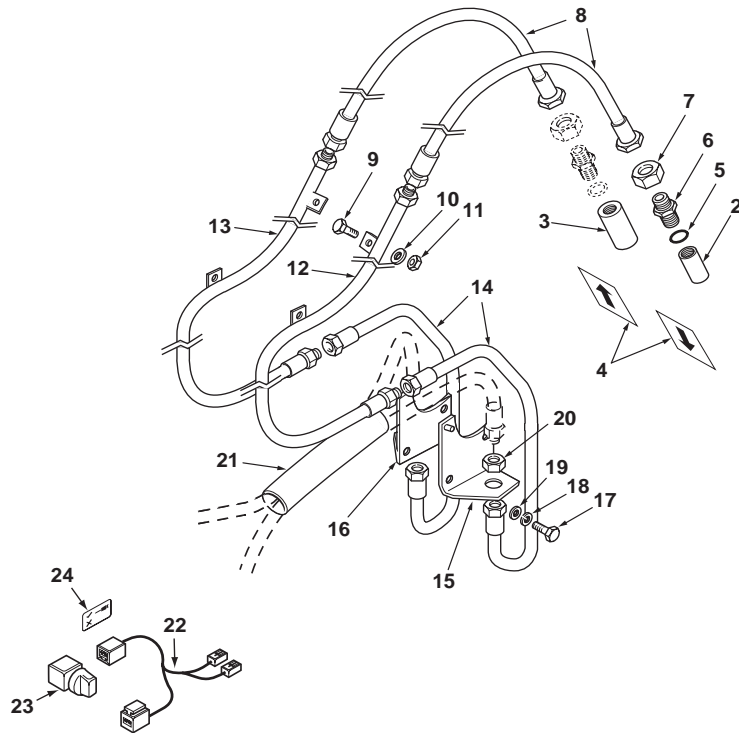

1	6110190M91		4.9 CM Aux with Extendahoe ROPS	1	Kit, Installation	Colis d'installation	Juego de instalación
2	3516796M91	1	Male	1	Coupler, Quick	Coupleur rapide	Acoplador rápido
3	3516797M91	1	Female	1	Coupler, Quick	Coupleur rapide	Acoplador rápido
4	6106080M1	1	Arrow	2	Decal	Adhésif	Adhesivo
5	835025M1	1		2	O-Ring	Joint torique	Junta de tipo O
6	356269X1	1		2	Connector, Bulkhead	Passe-cloison	Pasatabiques
7	355575X1	1		2	Nut, Lock	Écrou de blocage	Tuerca de retención
8	6106190M91	1		2	Hose Assy	Ensemble de flexible	Flexible, Conj.
9	339761X1	1	M8 x 25	4	Screw	Vis	Tornillo
10	390972X1	1	M8	4	Washer	Rondelle	Arandela
11	394367X1	1	M8	4	Nut, Lock	Écrou de blocage	Tuerca de retención
12	6106234M91	1	◀	1	Tube Assy	Tuyauterie	Conjunto de tubería
13	6106236M91	1	▶	1	Tube Assy	Tuyauterie	Conjunto de tubería
14	6106746M91	1		2	Hose Assy	Ensemble de flexible	Flexible, Conj.
15	3517380M93	1	◀	1	Bracket Assy	Ensemble chaise palier	Cuchara, Conj.
16	3517379M2	1	▶	1	Bracket	Patte de fixation	Pata de fijación
17	339123X1	1	M8 x 20	4	Bolt	Boulon	Perno
18	339374X1	1	M8	4	Washer, Lock	Rondelle de blocage	Arandela de freno
19	390972X1	1	M8	4	Washer	Rondelle	Arandela
20	355575X1	1		2	Nut, Lock	Écrou de blocage	Tuerca de retención
21	6106082M1	1		1	Sleeve	Chemise	Camisa
22	6107467M92	1		1	Harness Assy	Ensemble de faisceau	Haz, Conj.
23	6107165M91	1		1	Switch Assy	Ensemble commutat.	Conmutador, Conj.
24	6108710M1	1		1	Decal	Adhésif	Adhesivo



860 880
TX870B

812 816 824 844 854

98078C01.1

6199042M3

1

Jan-06

Auxiliary Hydraulics
Hydraulique Auxiliaire
Circuito hidráulico auxiliar

Centremount
Montage de Pelle Central
Excavadora de montaje central

Telescopic Dipper - Boom 4.9m
Balancier Télésopique - Flèche 4.9m
Balancín telescópico - Pluma 4.9m

Rops
Rops
Rops

C-98078-02.1-A

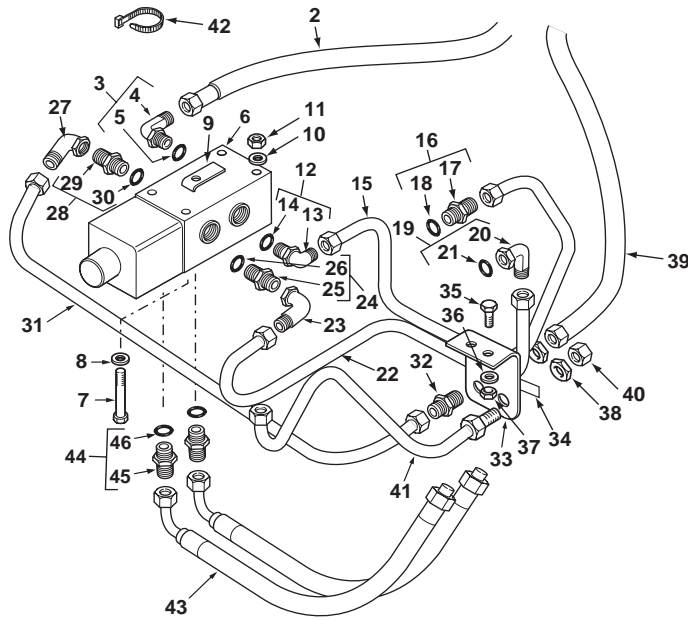

1	6110190M91		Continued 4.9 CM Aux with Extendahoe ROPS	1	Kit, Installation	Colis d'installation	Juego de instalación
2	6107468M92	1		1	Hose Assy	Ensemble de flexible	Flexible, Conj.
3	358764X91	1		1	Elbow, 90°	Coude à 90°	Codo, 90°
4		3	➡ Ref. 3	1	Elbow	Coude	Codo
5	835025M1	3		1	O-Ring	Joint torique	Junta de tipo O
6	6108292M91	1		1	Valve, Priority	Soupape de priorité	Válvula de prioridad
7	3019894X1	1	M6 x 100	3	Screw	Vis	Tornillo
8	391038X1	1	M6	3	Washer	Rondelle	Arandela
9	6108445M1	1		1	Bracket	Patte de fixation	Pata de fijación
10	390971X1	1	M6	3	Washer	Rondelle	Arandela
11	1441500X1	1	M6	3	Nut, Lock	Écrou de blocage	Tuerca de retención
12	358764X91	1		1	Elbow, 90°	Coude à 90°	Codo, 90°
13		12	➡ Ref. 12	1	Elbow	Coude	Codo
14	835025M1	12		1	O-Ring	Joint torique	Junta de tipo O
15	6109620M91	1		1	Tube Assy	Tuyauterie	Conjunto de tubería
16	835057M91	1		1	Connector Assy	Ensemble connexion	Conexión, Conj.
17		16	➡ Ref. 16	1	Connector	Connecteur	Conector
18	835025M1	16		1	O-Ring	Joint torique	Junta de tipo O
19	358764X91	1		1	Elbow, 90°	Coude à 90°	Codo, 90°
20		19	➡ Ref. 19	1	Elbow	Coude	Codo
21	835025M1	19		1	O-Ring	Joint torique	Junta de tipo O
22	6109622M91	1		1	Tube Assy	Tuyauterie	Conjunto de tubería
23	366462X1	1		1	Elbow, 90°	Coude à 90°	Codo, 90°
24	835057M91	1		1	Connector Assy	Ensemble connexion	Conexión, Conj.
25		24	➡ Ref. 24	1	Connector	Connecteur	Conector
26	835025M1	24		1	O-Ring	Joint torique	Junta de tipo O
27	366462X1	1		1	Elbow, 90°	Coude à 90°	Codo, 90°
28	835057M91	1		1	Connector Assy	Ensemble connexion	Conexión, Conj.
29		28	➡ Ref. 28	1	Connector	Connecteur	Conector
30	835025M1	28		1	O-Ring	Joint torique	Junta de tipo O
31	6109766M91	1		1	Tube Assy	Tuyauterie	Conjunto de tubería
32	356269X1	1		1	Connector, Bulkhead	Passe-cloison	Pasatabiques
33	6109769M1	1		1	Bracket	Patte de fixation	Pata de fijación
34	6109770M1	1		1	Decal	Adhésif	Adhesivo
35	339804X1	1	M6 x 25	2	Screw	Vis	Tornillo
36	390971X1	1	M6	2	Washer	Rondelle	Arandela
37	1441500X1	1	M6	2	Nut, Lock	Écrou de blocage	Tuerca de retención
38	355575X1	1		2	Nut, Lock	Écrou de blocage	Tuerca de retención
39	6109768M91	1		1	Hose Assy	Ensemble de flexible	Flexible, Conj.
40	355782X1	1		1	Plug, Blank-Off	Obturbateur	Obturador
41	6110023M91	1		1	Tube Assy	Tuyauterie	Conjunto de tubería
42	1862425M1	1		6	Tie, Cable	Attache câble	Enlace de Cable



860 880
TX870B

812 816 824 844 854

98078C02.1

6199042M3

1

Jan-06

Auxiliary Hydraulics
Hydraulique Auxiliaire
Circuito hidráulico auxiliar

Centremount
Montage de Pelle Central
Excavadora de montaje central

Telescopic Dipper - Boom 4.9m
Balancier Télescopique - Flèche 4.9m
Balancín telescópico - Pluma 4.9m

Rops
Rops
Rops

C-98078-02.1-A

43	6109552M91	1		2	Hose Assy	Ensemble de flexible	Flexible, Conj.
44	365715X91	1	1,1/16" - 7/8" UNF	2	Connector Assy	Ensemble connexion	Conexión, Conj.
45		44	➡ Ref. 44	1	Connector	Connecteur	Conector
46	835025M1	44		1	O-Ring	Joint torique	Junta de tipo O

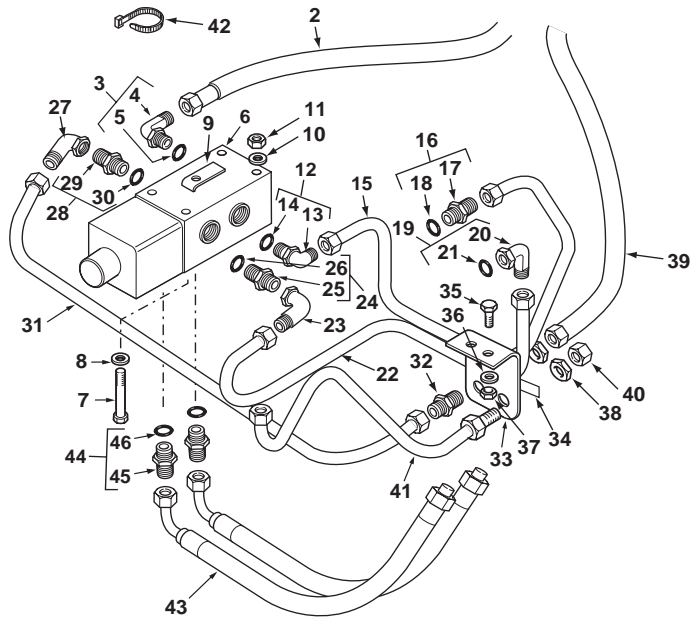

860 880
TX870B

812 816 824 844 854

Auxiliary Hydraulics
Hydraulique Auxiliaire
Circuito hidráulico auxiliar

Centremount
Montage de Pelle Central
Excavadora de montaje central

Telescopic Dipper - Boom 4.9m
Balancier Téléscopique - Flèche 4.9m
Balancín telescópico - Pluma 4.9m

4 Wheel Steer
 4 Wheel Steer
 4 Wheel Steer

C-98080-01.1-A

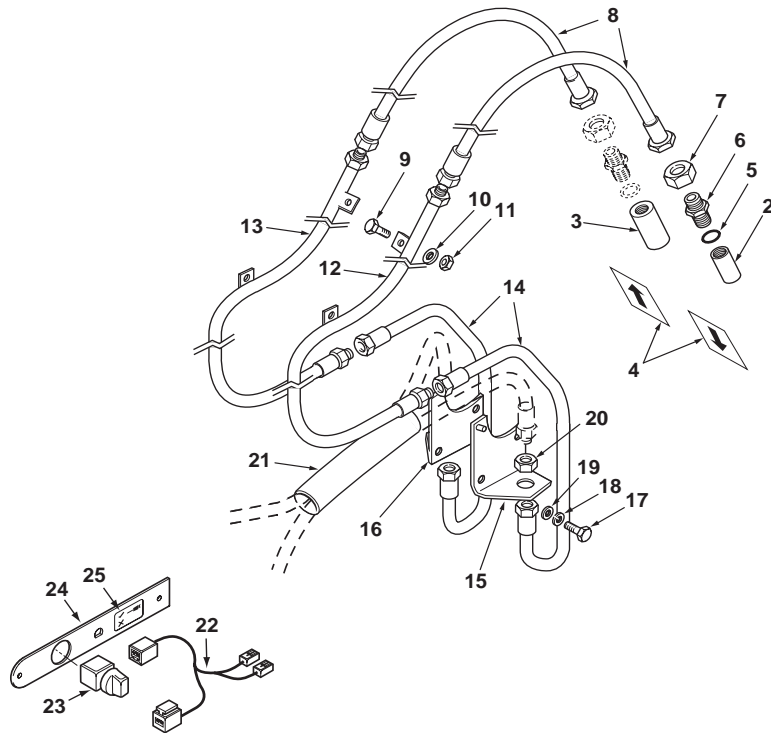

1	6110192M91		4.9 CM Aux with Extendahoe 4WS	1	Kit, Installation	Colis d'installation	Juego de instalación
2	3516796M91	1	Male	1	Coupler, Quick	Coupleur rapide	Acoplador rápido
3	3516797M91	1	Female	1	Coupler, Quick	Coupleur rapide	Acoplador rápido
4	6106080M1	1	Arrow	2	Decal	Adhésif	Adhesivo
5	835025M1	1		2	O-Ring	Joint torique	Junta de tipo O
6	356269X1	1		2	Connector, Bulkhead	Passe-cloison	Pasatabiques
7	355575X1	1		2	Nut, Lock	Écrou de blocage	Tuerca de retención
8	6106190M91	1		2	Hose Assy	Ensemble de flexible	Flexible, Conj.
9	339761X1	1	M8 x 25	4	Screw	Vis	Tornillo
10	390972X1	1	M8	4	Washer	Rondelle	Arandela
11	394367X1	1	M8	4	Nut, Lock	Écrou de blocage	Tuerca de retención
12	6106234M91	1	◀	1	Tube Assy	Tuyauterie	Conjunto de tubería
13	6106236M91	1	▶	1	Tube Assy	Tuyauterie	Conjunto de tubería
14	6106746M91	1		2	Hose Assy	Ensemble de flexible	Flexible, Conj.
15	3517380M93	1	◀	1	Bracket Assy	Ensemble chaise palier	Cuchara, Conj.
16	3517379M2	1	▶	1	Bracket	Patte de fixation	Pata de fijación
17	339123X1	1	M8 x 20	4	Bolt	Boulon	Perno
18	339374X1	1	M8	4	Washer, Lock	Rondelle de blocage	Arandela de freno
19	390972X1	1	M8	4	Washer	Rondelle	Arandela
20	355575X1	1		2	Nut, Lock	Écrou de blocage	Tuerca de retención
21	6106082M1	1		1	Sleeve	Chemise	Camisa
22	6107467M92	1		1	Harness Assy	Ensemble de faisceau	Haz, Conj.
23	6107165M91	1		1	Switch Assy	Ensemble commutat.	Conmutador, Conj.
24	6110013M1	1		1	Plate	Plaque	Placa
25	6109757M1	1		1	Decal	Adhésif	Adhesivo



970 980
 TX970B

923 932

98080C01.1

6199042M3

1

Jan-06

Auxiliary Hydraulics
Hydraulique Auxiliaire
Circuito hidráulico auxiliar

Centremount
Montage de Pelle Central
Excavadora de montaje central

Telescopic Dipper - Boom 4.9m
Balancier Télésopique - Flèche 4.9m
Balancín telescópico - Pluma 4.9m

4 Wheel Steer
 4 Wheel Steer
 4 Wheel Steer

C-98080-02.1-A

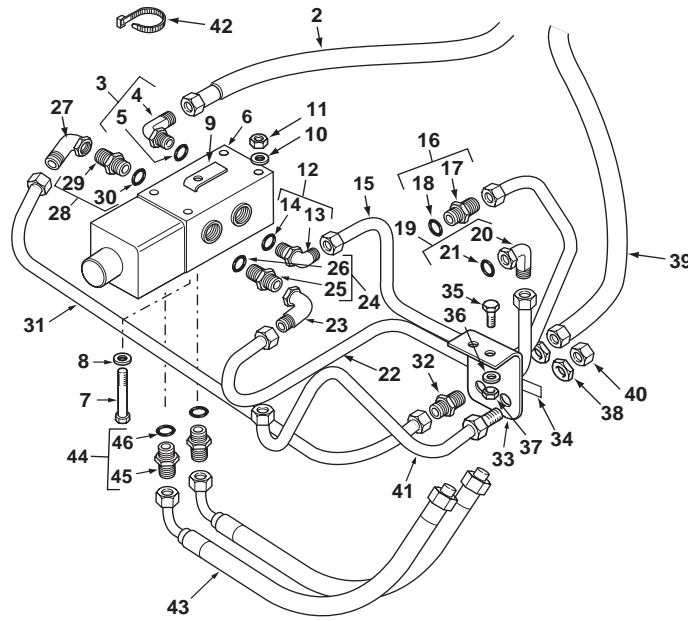

1	6110192M91		Continued 4.9 CM Aux with Extendahoe 4WS	1	Kit, Installation	Colis d'installation	Juego de instalación
2	6107468M92	1		1	Hose Assy	Ensemble de flexible	Flexible, Conj.
3	358764X91	1		1	Elbow, 90°	Coude à 90°	Codo, 90°
4		3	➡ Ref. 3	1	Elbow	Coude	Codo
5	835025M1	3		1	O-Ring	Joint torique	Junta de tipo O
6	6108292M91	1		1	Valve, Priority	Soupape de priorité	Válvula de prioridad
7	3019894X1	1	M6 x 100	3	Screw	Vis	Tornillo
8	391038X1	1	M6	3	Washer	Rondelle	Arandela
9	6108445M1	1		1	Bracket	Patte de fixation	Pata de fijación
10	390971X1	1	M6	3	Washer	Rondelle	Arandela
11	1441500X1	1	M6	3	Nut, Lock	Écrou de blocage	Tuerca de retención
12	358764X91	1		1	Elbow, 90°	Coude à 90°	Codo, 90°
13		12	➡ Ref. 12	1	Elbow	Coude	Codo
14	835025M1	12		1	O-Ring	Joint torique	Junta de tipo O
15	6109620M91	1		1	Tube Assy	Tuyauterie	Conjunto de tubería
16	835057M91	1		1	Connector Assy	Ensemble connexion	Conexión, Conj.
17		16	➡ Ref. 16	1	Connector	Connecteur	Conector
18	835025M1	16		1	O-Ring	Joint torique	Junta de tipo O
19	358764X91	1		1	Elbow, 90°	Coude à 90°	Codo, 90°
20		19	➡ Ref. 19	1	Elbow	Coude	Codo
21	835025M1	19		1	O-Ring	Joint torique	Junta de tipo O
22	6109622M91	1		1	Tube Assy	Tuyauterie	Conjunto de tubería
23	366462X1	1		1	Elbow, 90°	Coude à 90°	Codo, 90°
24	835057M91	1		1	Connector Assy	Ensemble connexion	Conexión, Conj.
25		24	➡ Ref. 24	1	Connector	Connecteur	Conector
26	835025M1	24		1	O-Ring	Joint torique	Junta de tipo O
27	366462X1	1		1	Elbow, 90°	Coude à 90°	Codo, 90°
28	835057M91	1		1	Connector Assy	Ensemble connexion	Conexión, Conj.
29		28	➡ Ref. 28	1	Connector	Connecteur	Conector
30	835025M1	28		1	O-Ring	Joint torique	Junta de tipo O
31	6109766M91	1		1	Tube Assy	Tuyauterie	Conjunto de tubería
32	356269X1	1		1	Connector, Bulkhead	Passe-cloison	Pasatabiques
33	6109769M1	1		1	Bracket	Patte de fixation	Pata de fijación
34	6109770M1	1		1	Decal	Adhésif	Adhesivo
35	339804X1	1	M6 x 25	2	Screw	Vis	Tornillo
36	390971X1	1	M6	2	Washer	Rondelle	Arandela
37	1441500X1	1	M6	2	Nut, Lock	Écrou de blocage	Tuerca de retención
38	355575X1	1		2	Nut, Lock	Écrou de blocage	Tuerca de retención
39	6109768M91	1		1	Hose Assy	Ensemble de flexible	Flexible, Conj.
40	355782X1	1		1	Plug, Blank-Off	Obturateur	Obturador
41	6110023M91	1		1	Tube Assy	Tuyauterie	Conjunto de tubería
42	1862425M1	1		6	Tie, Cable	Attache câble	Enlace de Cable
43	6109552M91	1		2	Hose Assy	Ensemble de flexible	Flexible, Conj.



970 980
TX970B

923 932

98080C02.1

6199042M3

1

Jan-06

Auxiliary Hydraulics
Hydraulique Auxiliaire
Circuito hidráulico auxiliar

Centremount
Montage de Pelle Central
Excavadora de montaje central

Telescopic Dipper - Boom 4.9m
 Balancier Téléscopique - Flèche 4.9m
 Balancín telescópico - Pluma 4.9m

4 Wheel Steer
 4 Wheel Steer
 4 Wheel Steer

C-98080-02.1-A

44	365715X91	1	1,1/16" - 7/8" UNF	2	Connector Assy	Ensemble connexion	Conexión, Conj.
45		44	 Ref. 44	1	Connector	Connecteur	Conector
46	835025M1	44		1	O-Ring	Joint torique	Junta de tipo O

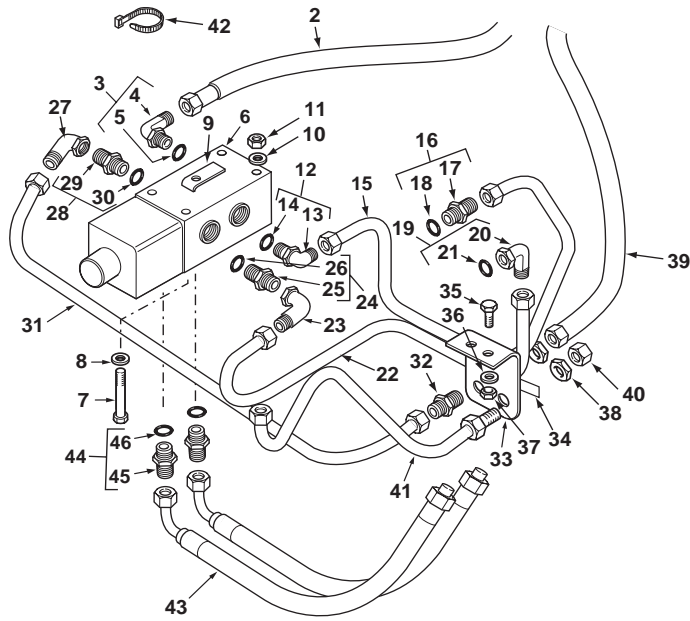

970 980
 TX970B

923 932

Auxiliary Hydraulics
Hydraulique Auxiliaire
Circuito hidráulico auxiliar

Centremount
Montage de Pelle Central
Excavadora de montaje central

Standard Dipper
Balancier Standard
Balancín estándar

4.5m
 4.5m
 4.5m

AC-98082-01.1-A

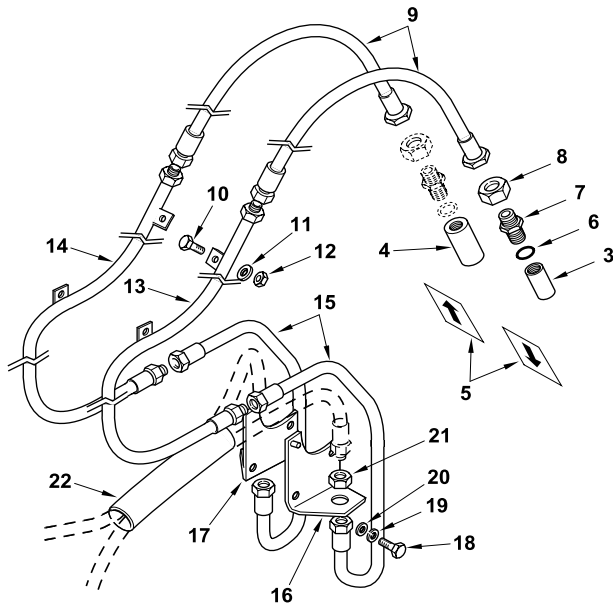

1	ACC82A			1	Accessory code	Code accessoire	Código accesorio
2	6110194M91	1	CM Aux 4.5 Std Dipper	1	Kit, Installation	Colis d'installation	Juego de instalación
3	3516796M91	2	Male	1	Coupler, Quick	Coupleur rapide	Acoplador rápido
4	3516797M91	2	Female	1	Coupler, Quick	Coupleur rapide	Acoplador rápido
5	6106080M1	2	Arrow	2	Decal	Adhésif	Adhesivo
6	835025M1	2		2	O-Ring	Joint torique	Junta de tipo O
7	356269X1	2		2	Connector, Bulkhead	Passe-cloison	Pasatabiques
8	355575X1	2		2	Nut, Lock	Écrou de blocage	Tuerca de retención
9	6106190M91	2		2	Hose Assy	Ensemble de flexible	Flexible, Conj.
10	339761X1	2	M8 x 25	4	Screw	Vis	Tornillo
11	390972X1	2	M8	4	Washer	Rondelle	Arandela
12	394367X1	2	M8	4	Nut, Lock	Écrou de blocage	Tuerca de retención
13	6106186M91	2	◀	1	Tube Assy	Tuyauterie	Conjunto de tubería
14	6106188M91	2	▶	1	Tube Assy	Tuyauterie	Conjunto de tubería
15	6106746M91	2		2	Hose Assy	Ensemble de flexible	Flexible, Conj.
16	3517380M93	2	◀	1	Bracket Assy	Ensemble chaise palier	Cuchara, Conj.
17	3517379M2	2	▶	1	Bracket	Patte de fixation	Pata de fijación
18	339123X1	2	M8 x 20	4	Bolt	Boulon	Perno
19	339374X1	2	M8	4	Washer, Lock	Rondelle de blocage	Arandela de freno
20	390972X1	2	M8	4	Washer	Rondelle	Arandela
21	355575X1	2		2	Nut, Lock	Écrou de blocage	Tuerca de retención
22	6106082M1	2		1	Sleeve	Chemise	Camisa



820 860 880 970
 TX760B TX860B

801 802 803 804 809 810 813 814 821 822 831 832 841 842 851 852 922

98082AC01.1

6199042M3

1

Jan-06

Auxiliary Hydraulics
Hydraulique Auxiliaire
Circuito hidráulico auxiliar

Centremount
Montage de Pelle Central
Excavadora de montaje central

Standard Dipper
Balancier Standard
Balancín estándar

4.5m
 4.5m
 4.5m

AC-98082-02.1-A

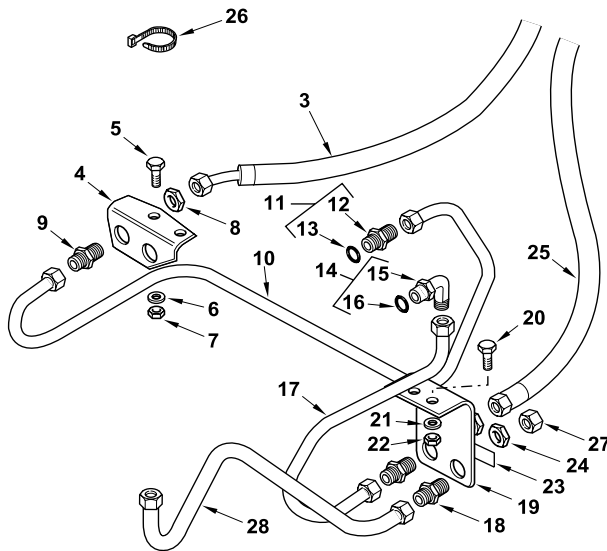

1	ACC82A		Continued	1	Accessory code	Code accessoire	Código accesorio
2	6110194M91	1	Continued CM Aux 4.5 Std Dipper	1	Kit, Installation	Colis d'installation	Juego de instalación
3	6107468M92	2		1	Hose Assy	Ensemble de flexible	Flexible, Conj.
4	6110076M1	2		1	Bracket	Patte de fixation	Pata de fijación
5	339804X1	2	M6 x 25	2	Screw	Vis	Tornillo
6	390971X1	2	M6	2	Washer	Rondelle	Arandela
7	1441500X1	2	M6	2	Nut, Lock	Écrou de blocage	Tuerca de retención
8	355575X1	2		1	Nut, Lock	Écrou de blocage	Tuerca de retención
9	356269X1	2		1	Connector, Bulkhead	Passe-cloison	Pasatabiques
10	6110077M91	2		1	Tube Assy	Tuyauterie	Conjunto de tubería
11	835057M91	2		1	Connector Assy	Ensemble connexion	Conexión, Conj.
12		11	➡ Ref. 11	1	Connector	Connecteur	Conector
13	835025M1	11		1	O-Ring	Joint torique	Junta de tipo O
14	358764X91	2		1	Elbow, 90°	Coude à 90°	Codo, 90°
15		14	➡ Ref. 14	1	Elbow	Coude	Codo
16	835025M1	14		1	O-Ring	Joint torique	Junta de tipo O
17	6110079M91	2		1	Tube Assy	Tuyauterie	Conjunto de tubería
18	356269X1	2		1	Connector, Bulkhead	Passe-cloison	Pasatabiques
19	6109769M1	2		1	Bracket	Patte de fixation	Pata de fijación
20	339804X1	2	M6 x 25	2	Screw	Vis	Tornillo
21	390971X1	2	M6	2	Washer	Rondelle	Arandela
22	1441500X1	2	M6	2	Nut, Lock	Écrou de blocage	Tuerca de retención
23	6109770M1	2		1	Decal	Adhésif	Adhesivo
24	355575X1	2		2	Nut, Lock	Écrou de blocage	Tuerca de retención
25	6109768M91	2		1	Hose Assy	Ensemble de flexible	Flexible, Conj.
26	1862425M1	2		6	Tie, Cable	Attache câble	Enlace de Cable
27	355782X1	2		1	Plug, Blank-Off	Obturateur	Obturador
28	6110023M91	2		1	Tube Assy	Tuyauterie	Conjunto de tubería



820 860 880 970
 TX760B TX860B

801 802 803 804 809 810 813 814 821 822 831 832 841 842 851 852 922

Auxiliary Hydraulics
Hydraulique Auxiliaire
Circuito hidráulico auxiliar

Centremount
Montage de Pelle Central
Excavadora de montaje central

Control Pedal
Pédale de Commande
Pedal de control

AC-98082-03.1-A

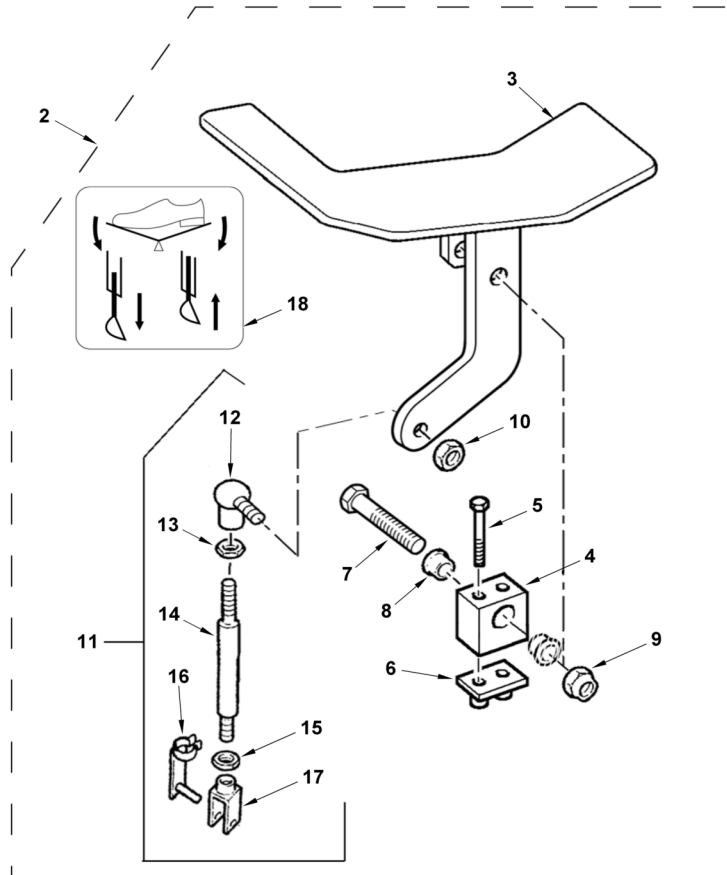

1	ACC82A		Continued	1	Accessory code	Code accessoire	Código accesorio
2	6110194M91	1	Continued CM Aux 4.5 Std Dipper	1	Kit, Installation	Colis d'installation	Juego de instalación
3	6106874M91	2		1	Pedal Assy	Ensemble de pédale	Pedal, Conj.
4	6106734M1	2		1	Pivot	Pivot	Pivote
5	3001758X1	2	M6 x 50	2	Screw	Vis	Tornillo
6	3519538M1	2		1	Plate, Base	Plaque de base	Placa de base
7	6106981M1	2	M10 x 60	1	Bolt	Boulon	Perno
8	6106866M1	2		2	Bushing	Bague	Anillo
9	1440329X1	2	M10	1	Nut, Lock	Écrou de blocage	Tuerca de retención
10	394367X1	2	M8	1	Nut, Lock	Écrou de blocage	Tuerca de retención
11	6106724M92	2		1	Rod Assy	Ensemble tringlerie	Tirantes, Conj.
12	3517518M1	11		1	Ball Joint	Rotule	Rotula
13	339169X1	11	M8	1	Nut	Écrou	Tuerca
14		11	Ref.10	1	Rod	Tringle	Vástago
15	3519650M1	11	M8 LH Thread	1	Nut	Écrou	Tuerca
16	3520666M1	11		1	Pin, Clevis	Axe de chape	Eje de brida
17	3519590M1	11	LH Thread	1	Clevis	Chape	Brida
18	6101865M2	2		1	Decal	Adhésif	Adhesivo



820 860 880 970
 TX760B TX860B

801 802 803 804 809 810 813 814 821 822 831 832 841 842 851 852 922

98082AC03.1

6199042M3

1

Jan-06

Auxiliary Hydraulics
Hydraulique Auxiliaire
Circuito hidráulico auxiliar

Centremount
Montage de Pelle Central
Excavadora de montaje central

Standard Dipper
Balancier Standard
Balancín estándar

4.5m
 4.5m
 4.5m

C-98082-01.1-A

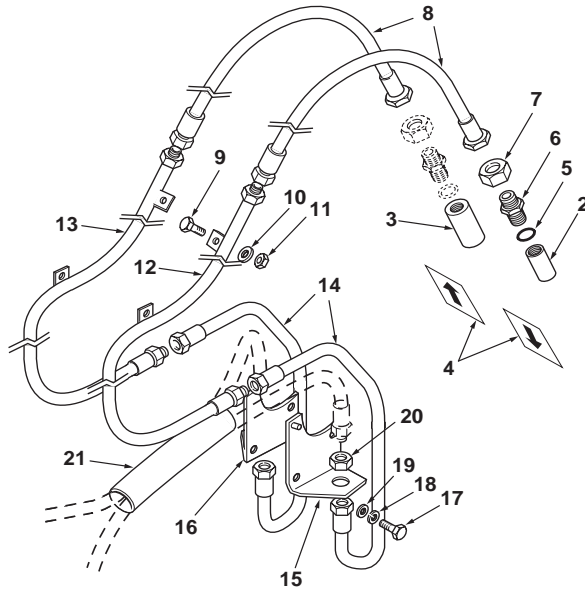

1	6110194M91		CM Aux 4.5 Std Dipper	1	Kit, Installation	Colis d'installation	Juego de instalación
2	3516796M91	1	Male	1	Coupler, Quick	Coupleur rapide	Acoplador rápido
3	3516797M91	1	Female	1	Coupler, Quick	Coupleur rapide	Acoplador rápido
4	6106080M1	1	Arrow	2	Decal	Adhésif	Adhesivo
5	835025M1	1		2	O-Ring	Joint torique	Junta de tipo O
6	356269X1	1		2	Connector, Bulkhead	Passe-cloison	Pasatabiques
7	355575X1	1		2	Nut, Lock	Écrou de blocage	Tuerca de retención
8	6106190M91	1		2	Hose Assy	Ensemble de flexible	Flexible, Conj.
9	339761X1	1	M8 x 25	4	Screw	Vis	Tornillo
10	390972X1	1	M8	4	Washer	Rondelle	Arandela
11	394367X1	1	M8	4	Nut, Lock	Écrou de blocage	Tuerca de retención
12	6106186M91	1	◀	1	Tube Assy	Tuyauterie	Conjunto de tubería
13	6106188M91	1	▶	1	Tube Assy	Tuyauterie	Conjunto de tubería
14	6106746M91	1		2	Hose Assy	Ensemble de flexible	Flexible, Conj.
15	3517380M93	1	◀	1	Bracket Assy	Ensemble chaise palier	Cuchara, Conj.
16	3517379M2	1	▶	1	Bracket	Patte de fixation	Pata de fijación
17	339123X1	1	M8 x 20	4	Bolt	Boulon	Perno
18	339374X1	1	M8	4	Washer, Lock	Rondelle de blocage	Arandela de freno
19	390972X1	1	M8	4	Washer	Rondelle	Arandela
20	355575X1	1		2	Nut, Lock	Écrou de blocage	Tuerca de retención
21	6106082M1	1		1	Sleeve	Chemise	Camisa



820 860 880 970
 TX760B TX860B

801 802 803 804 809 810 813 814 821 822 831 832 841 842 851 852 922

98082C01.1

6199042M3

1

Jan-06

Auxiliary Hydraulics
Hydraulique Auxiliaire
Circuito hidráulico auxiliar

Centremount
Montage de Pelle Central
Excavadora de montaje central

Standard Dipper
Balancier Standard
Balancín estándar

4.5m
 4.5m
 4.5m

C-98082-02.1-A

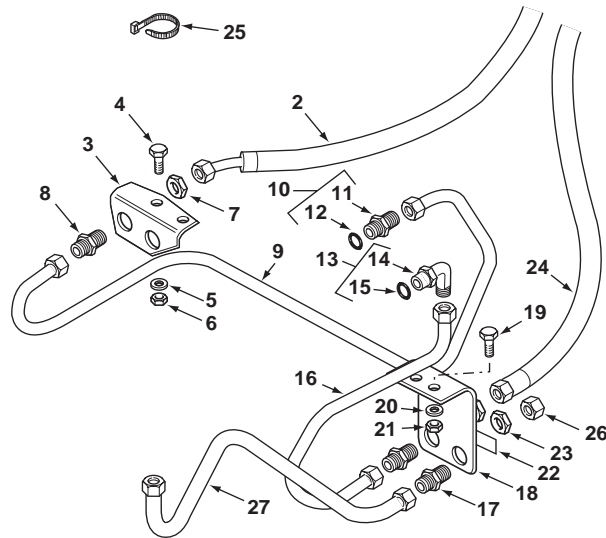

1	6110194M91		Continued CM Aux 4.5 Std Dipper	1	Kit, Installation	Colis d'installation	Juego de instalación
2	6107468M92	1		1	Hose Assy	Ensemble de flexible	Flexible, Conj.
3	6110076M1	1		1	Bracket	Patte de fixation	Pata de fijación
4	339804X1	1	M6 x 25	2	Screw	Vis	Tornillo
5	390971X1	1	M6	2	Washer	Rondelle	Arandela
6	1441500X1	1	M6	2	Nut, Lock	Écrou de blocage	Tuerca de retención
7	355575X1	1		1	Nut, Lock	Écrou de blocage	Tuerca de retención
8	356269X1	1		1	Connector, Bulkhead	Passe-cloison	Pasatabiques
9	6110077M91	1		1	Tube Assy	Tuyauterie	Conjunto de tubería
10	835057M91	1		1	Connector Assy	Ensemble connexion	Conexión, Conj.
11		10	➡ Ref. 10	1	Connector	Connecteur	Conector
12	835025M1	10		1	O-Ring	Joint torique	Junta de tipo O
13	358764X91	1		1	Elbow, 90°	Coude à 90°	Codo, 90°
14		13	➡ Ref. 13	1	Elbow	Coude	Codo
15	835025M1	13		1	O-Ring	Joint torique	Junta de tipo O
16	6110079M91	1		1	Tube Assy	Tuyauterie	Conjunto de tubería
17	356269X1	1		1	Connector, Bulkhead	Passe-cloison	Pasatabiques
18	6109769M1	1		1	Bracket	Patte de fixation	Pata de fijación
19	339804X1	1	M6 x 25	2	Screw	Vis	Tornillo
20	390971X1	1	M6	2	Washer	Rondelle	Arandela
21	1441500X1	1	M6	2	Nut, Lock	Écrou de blocage	Tuerca de retención
22	6109770M1	1		1	Decal	Adhésif	Adhesivo
23	355575X1	1		2	Nut, Lock	Écrou de blocage	Tuerca de retención
24	6109768M91	1		1	Hose Assy	Ensemble de flexible	Flexible, Conj.
25	1862425M1	1		6	Tie, Cable	Attache câble	Enlace de Cable
26	355782X1	1		1	Plug, Blank-Off	Obturateur	Obturador
27	6110023M91	1		1	Tube Assy	Tuyauterie	Conjunto de tubería



820 860 880 970
 TX760B TX860B

801 802 803 804 809 810 813 814 821 822 831 832 841 842 851 852 922

98082C02.1

6199042M3

1

Jan-06

Auxiliary Hydraulics
Hydraulique Auxiliaire
Circuito hidráulico auxiliar

Centremount
Montage de Pelle Central
Excavadora de montaje central

Control Pedal
Pédale de Commande
Pedal de control

C-98082-03.1-A

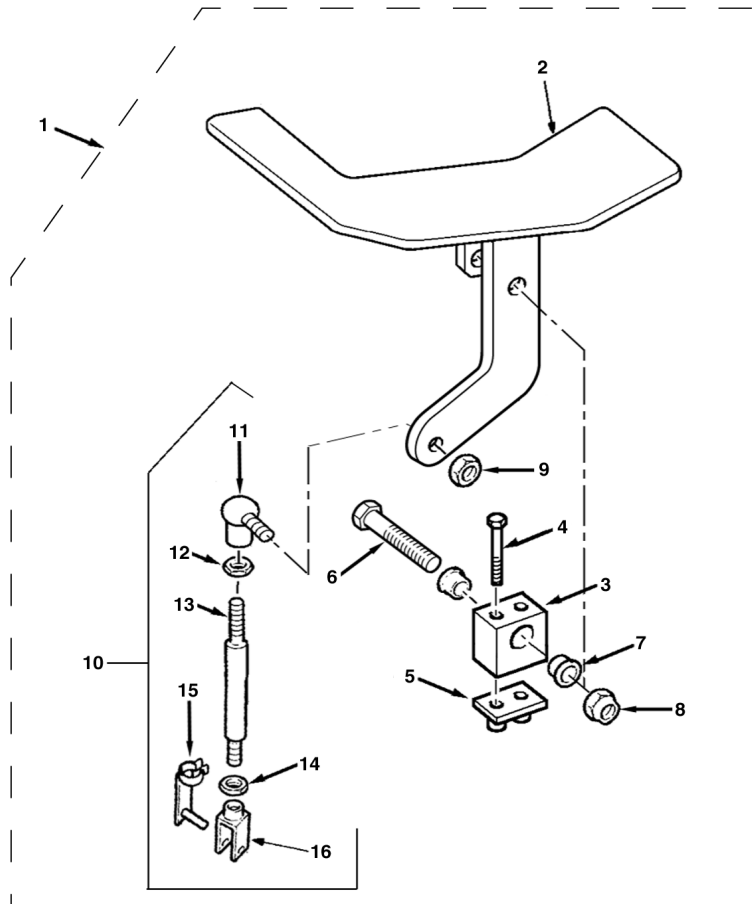

1	6110194M91		Continued CM Aux 4.5 Std Dipper	1	Kit, Installation	Colis d'installation	Juego de instalación
2	6106874M91	1		1	Pedal Assy	Ensemble de pédale	Pedal, Conj.
3	6106734M1	1		1	Pivot	Pivot	Pivote
4	3001758X1	1	M6 x 50	2	Screw	Vis	Tornillo
5	3519538M1	1		1	Plate, Base	Plaque de base	Placa de base
6	6106981M1	1	M10 x 60	1	Bolt	Boulon	Perno
7	6106866M1	1		2	Bushing	Bague	Anillo
8	1440329X1	1	M10	1	Nut, Lock	Écrou de blocage	Tuerca de retención
9	394367X1	1	M8	1	Nut, Lock	Écrou de blocage	Tuerca de retención
10	6106724M92	1		1	Rod Assy	Ensemble tringlerie	Tirantes, Conj.
11	3517518M1	10		1	Ball Joint	Rotule	Rotula
12	339169X1	10	M8	1	Nut	Écrou	Tuerca
13		10	➤ Ref.10	1	Rod	Tringle	Vástago
14	3519650M1	10	M8 LH Thread	1	Nut	Écrou	Tuerca
15	3520666M1	10		1	Pin, Clevis	Axe de chape	Eje de brida
16	3519590M1	10	LH Thread	1	Clevis	Chape	Brida
17	6101865M2	1		1	Decal	Adhésif	Adhesivo



820 860 880 970
 TX760B TX860B

801 802 803 804 809 810 813 814 821 822 831 832 841 842 851 852 922

98082C03.1

6199042M3

1

Jan-06

Auxiliary Hydraulics
Hydraulique Auxiliaire
Circuito hidráulico auxiliar

Centremount
Montage de Pelle Central
Excavadora de montaje central

Standard Dipper
Balancier Standard
Balancín estándar

4.9m
 4.9m
 4.9m

AC-98083-01.1-A

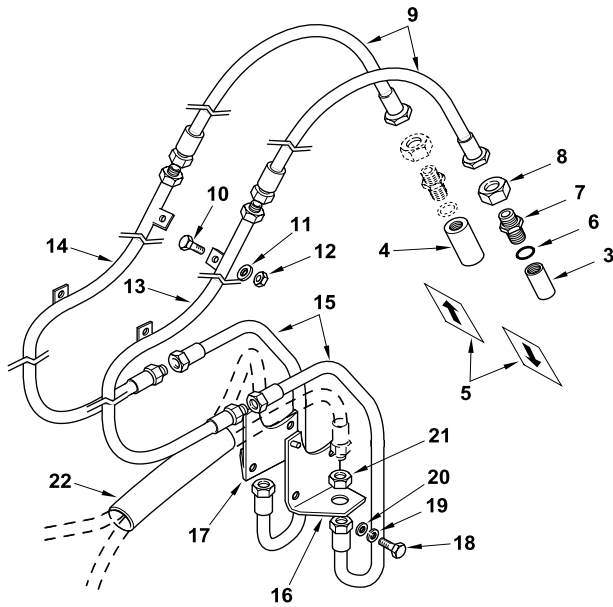

1	ACC82C			1	Accessory code	Code accessoire	Código accesorio
2	6110195M91	1	CM Aux 4.9 Std Dipper	1	Kit, Installation	Colis d'installation	Juego de instalación
3	3516796M91	2	Male	1	Coupler, Quick	Coupleur rapide	Acoplador rápido
4	3516797M91	2	Female	1	Coupler, Quick	Coupleur rapide	Acoplador rápido
5	6106080M1	2	Arrow	2	Decal	Adhésif	Adhesivo
6	835025M1	2		2	O-Ring	Joint torique	Junta de tipo O
7	356269X1	2		2	Connector, Bulkhead	Passe-cloison	Pasatabiques
8	355575X1	2		2	Nut, Lock	Écrou de blocage	Tuerca de retención
9	6106190M91	2		2	Hose Assy	Ensemble de flexible	Flexible, Conj.
10	339761X1	2	M8 x 25	4	Screw	Vis	Tornillo
11	390972X1	2	M8	4	Washer	Rondelle	Arandela
12	394367X1	2	M8	4	Nut, Lock	Écrou de blocage	Tuerca de retención
13	6106234M91	2	◀	1	Tube Assy	Tuyauterie	Conjunto de tubería
14	6106236M91	2	▶	1	Tube Assy	Tuyauterie	Conjunto de tubería
15	6106746M91	2		2	Hose Assy	Ensemble de flexible	Flexible, Conj.
16	3517380M93	2	◀	1	Bracket Assy	Ensemble chaise palier	Cuchara, Conj.
17	3517379M2	2	▶	1	Bracket	Patte de fixation	Pata de fijación
18	339123X1	2	M8 x 20	4	Bolt	Boulon	Perno
19	339374X1	2	M8	4	Washer, Lock	Rondelle de blocage	Arandela de freno
20	390972X1	2	M8	4	Washer	Rondelle	Arandela
21	355575X1	2		2	Nut, Lock	Écrou de blocage	Tuerca de retención
22	6106082M1	2		1	Sleeve	Chemise	Camisa



860 880 970 980
 TX870B TX970B

811 812 815 816 823 824 843 853 854 923 932

98083AC01.1

6199042M3

1

Jan-06

Auxiliary Hydraulics
Hydraulique Auxiliaire
Circuito hidráulico auxiliar

Centremount
Montage de Pelle Central
Excavadora de montaje central

Standard Dipper
Balancier Standard
Balancín estándar

4.9m
 4.9m
 4.9m

AC-98083-02.1-A

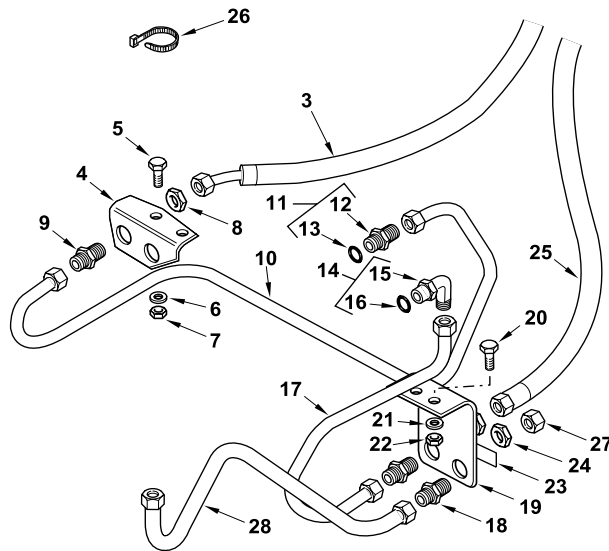

1	ACC82C		Continued	1	Accessory code	Code accessoire	Código accesorio
2	6110195M91	1	Continued CM Aux 4.9 Std Dipper	1	Kit, Installation	Colis d'installation	Juego de instalación
3	6107468M92	2		1	Hose Assy	Ensemble de flexible	Flexible, Conj.
4	6110076M1	2		1	Bracket	Patte de fixation	Pata de fijación
5	339804X1	2	M6 x 25	2	Screw	Vis	Tornillo
6	390971X1	2	M6	2	Washer	Rondelle	Arandela
7	1441500X1	2	M6	2	Nut, Lock	Écrou de blocage	Tuerca de retención
8	355575X1	2		1	Nut, Lock	Écrou de blocage	Tuerca de retención
9	356269X1	2		1	Connector, Bulkhead	Passe-cloison	Pasatabiques
10	6110077M91	2		1	Tube Assy	Tuyauterie	Conjunto de tubería
11	835057M91	2		1	Connector Assy	Ensemble connexion	Conexión, Conj.
12		11	➡ Ref. 11	1	Connector	Connecteur	Conector
13	835025M1	11		1	O-Ring	Joint torique	Junta de tipo O
14	358764X91	2		1	Elbow, 90°	Coude à 90°	Codo, 90°
15		14	➡ Ref. 14	1	Elbow	Coude	Codo
16	835025M1	14		1	O-Ring	Joint torique	Junta de tipo O
17	6110079M91	2		1	Tube Assy	Tuyauterie	Conjunto de tubería
18	356269X1	2		1	Connector, Bulkhead	Passe-cloison	Pasatabiques
19	6109769M1	2		1	Bracket	Patte de fixation	Pata de fijación
20	339804X1	2	M6 x 25	2	Screw	Vis	Tornillo
21	390971X1	2	M6	2	Washer	Rondelle	Arandela
22	1441500X1	2	M6	2	Nut, Lock	Écrou de blocage	Tuerca de retención
23	6109770M1	2		1	Decal	Adhésif	Adhesivo
24	355575X1	2		2	Nut, Lock	Écrou de blocage	Tuerca de retención
25	6109768M91	2		1	Hose Assy	Ensemble de flexible	Flexible, Conj.
26	1862425M1	2		6	Tie, Cable	Attache câble	Enlace de Cable
27	355782X1	2		1	Plug, Blank-Off	Obturateur	Obturador
28	6110023M91	2		1	Tube Assy	Tuyauterie	Conjunto de tubería



860 880 970 980
 TX870B TX970B

811 812 815 816 823 824 843 853 854 923 932

Auxiliary Hydraulics
Hydraulique Auxiliaire
Circuito hidráulico auxiliar

Centremount
Montage de Pelle Central
Excavadora de montaje central

Control Pedal
Pédale de Commande
Pedal de control

AC-98083-03.1-A

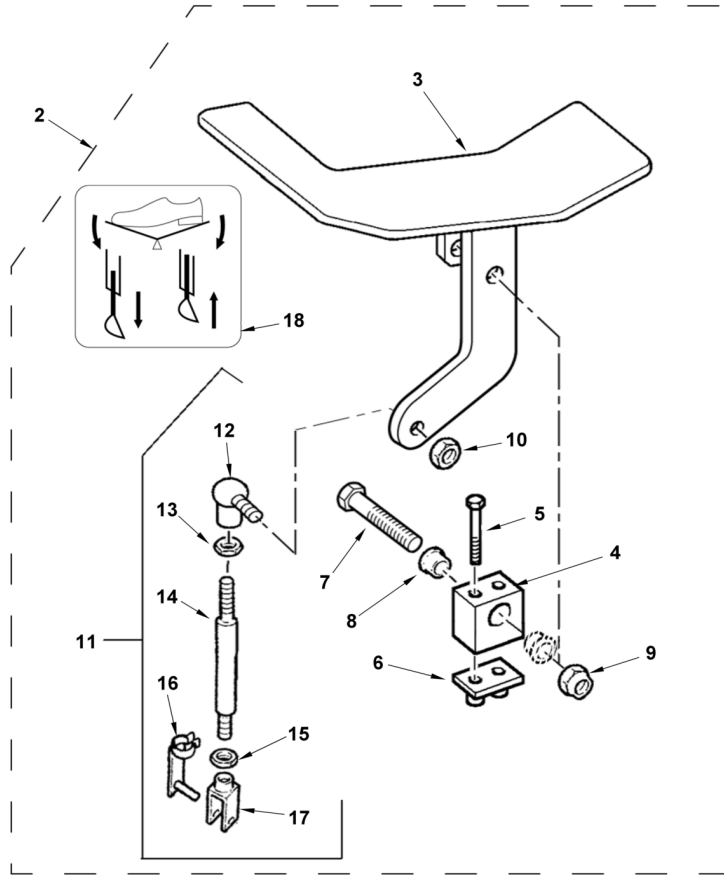

1	ACC82C		Continued	1	Accessory code	Code accessoire	Código accesorio
	6110195M91	1	Continued CM Aux 4.9 Std Dipper	1	Kit, Installation	Colis d'installation	Juego de instalación
2	6106874M91	2		1	Pedal Assy	Ensemble de pédale	Pedal, Conj.
3	6106734M1	2		1	Pivot	Pivot	Pivote
4	3001758X1	2	M6 x 50	2	Screw	Vis	Tornillo
5	3519538M1	2		1	Plate, Base	Plaque de base	Placa de base
6	6106981M1	2	M10 x 60	1	Bolt	Boulon	Perno
7	6106866M1	2		2	Bushing	Bague	Anillo
8	1440329X1	2	M10	1	Nut, Lock	Écrou de blocage	Tuerca de retención
9	394367X1	2	M8	1	Nut, Lock	Écrou de blocage	Tuerca de retención
10	6106724M92	2		1	Rod Assy	Ensemble tringlerie	Tirantes, Conj.
11	3517518M1	11		1	Ball Joint	Rotule	Rotula
12	339169X1	11	M8	1	Nut	Écrou	Tuerca
13		11	Ref.11	1	Rod	Tringle	Vástago
14	3519650M1	11	M8 LH Thread	1	Nut	Écrou	Tuerca
15	3520666M1	11		1	Pin, Clevis	Axe de chape	Eje de brida
16	3519590M1	11	LH Thread	1	Clevis	Chape	Brida
17	6101865M2	2		1	Decal	Adhésif	Adhesivo



860 880 970 980
 TX870B TX970B

811 812 815 816 823 824 843 853 854 923 932

98083AC03.1

6199042M3

1

Jan-06

Auxiliary Hydraulics
Hydraulique Auxiliaire
Circuito hidráulico auxiliar

Centremount
Montage de Pelle Central
Excavadora de montaje central

Standard Dipper
Balancier Standard
Balancín estándar

4.9m
 4.9m
 4.9m

C-98083-01.1-A

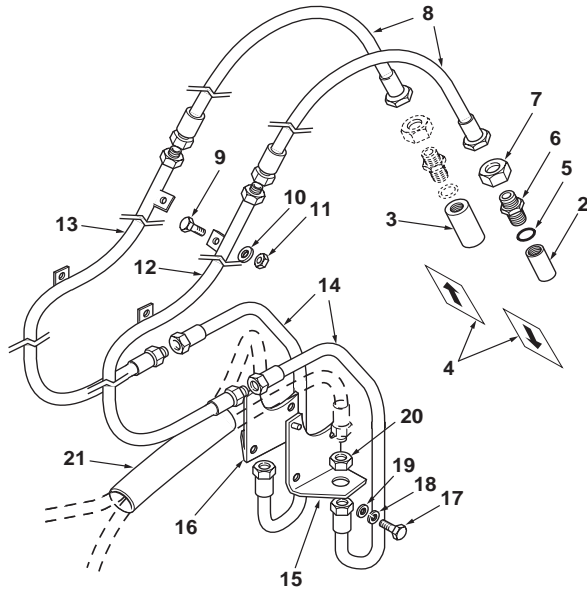

1	6110195M91		CM Aux 4.9 Std Dipper	1	Kit, Installation	Colis d'installation	Juego de instalación
2	3516796M91	1	Male	1	Coupler, Quick	Coupleur rapide	Acoplador rápido
3	3516797M91	1	Female	1	Coupler, Quick	Coupleur rapide	Acoplador rápido
4	6106080M1	1	Arrow	2	Decal	Adhésif	Adhesivo
5	835025M1	1		2	O-Ring	Joint torique	Junta de tipo O
6	356269X1	1		2	Connector, Bulkhead	Passe-cloison	Pasatabiques
7	355575X1	1		2	Nut, Lock	Écrou de blocage	Tuerca de retención
8	6106190M91	1		2	Hose Assy	Ensemble de flexible	Flexible, Conj.
9	339761X1	1	M8 x 25	4	Screw	Vis	Tornillo
10	390972X1	1	M8	4	Washer	Rondelle	Arandela
11	394367X1	1	M8	4	Nut, Lock	Écrou de blocage	Tuerca de retención
12	6106234M91	1	◀	1	Tube Assy	Tuyauterie	Conjunto de tubería
13	6106236M91	1	▶	1	Tube Assy	Tuyauterie	Conjunto de tubería
14	6106746M91	1		2	Hose Assy	Ensemble de flexible	Flexible, Conj.
15	3517380M93	1	◀	1	Bracket Assy	Ensemble chaise palier	Cuchara, Conj.
16	3517379M2	1	▶	1	Bracket	Patte de fixation	Pata de fijación
17	339123X1	1	M8 x 20	4	Bolt	Boulon	Perno
18	339374X1	1	M8	4	Washer, Lock	Rondelle de blocage	Arandela de freno
19	390972X1	1	M8	4	Washer	Rondelle	Arandela
20	355575X1	1		2	Nut, Lock	Écrou de blocage	Tuerca de retención
21	6106082M1	1		1	Sleeve	Chemise	Camisa



860 880 970 980
 TX870B TX970B

811 812 815 816 823 824 843 853 854 923 932

98083C01.1

6199042M3

1

Jan-06

Auxiliary Hydraulics
Hydraulique Auxiliaire
Circuito hidráulico auxiliar

Centremount
Montage de Pelle Central
Excavadora de montaje central

Standard Dipper
Balancier Standard
Balancín estándar

4.9m
 4.9m
 4.9m

C-98083-02.1-A

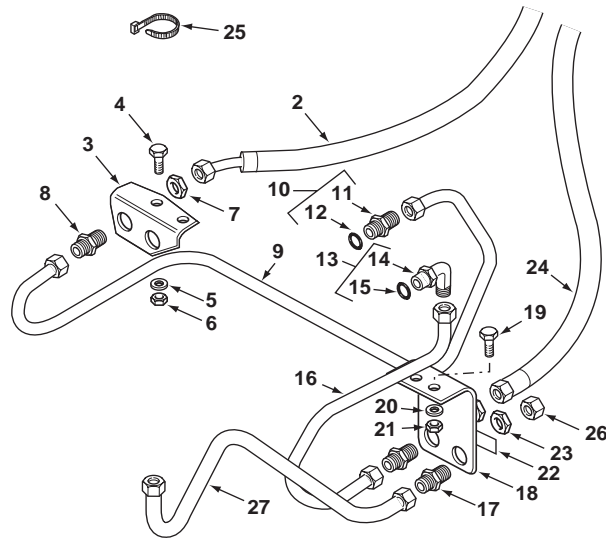

1	6110195M91		Continued CM Aux 4.9 Std Dipper	1	Kit, Installation	Colis d'installation	Juego de instalación
2	6107468M92	1		1	Hose Assy	Ensemble de flexible	Flexible, Conj.
3	6110076M1	1		1	Bracket	Patte de fixation	Pata de fijación
4	339804X1	1	M6 x 25	2	Screw	Vis	Tornillo
5	390971X1	1	M6	2	Washer	Rondelle	Arandela
6	1441500X1	1	M6	2	Nut, Lock	Écrou de blocage	Tuerca de retención
7	355575X1	1		1	Nut, Lock	Écrou de blocage	Tuerca de retención
8	356269X1	1		1	Connector, Bulkhead	Passe-cloison	Pasatabiques
9	6110077M91	1		1	Tube Assy	Tuyauterie	Conjunto de tubería
10	835057M91	1		1	Connector Assy	Ensemble connexion	Conexión, Conj.
11		10	➡ Ref. 10	1	Connector	Connecteur	Conector
12	835025M1	10		1	O-Ring	Joint torique	Junta de tipo O
13	358764X91	1		1	Elbow, 90°	Coude à 90°	Codo, 90°
14		13	➡ Ref. 13	1	Elbow	Coude	Codo
15	835025M1	13		1	O-Ring	Joint torique	Junta de tipo O
16	6110079M91	1		1	Tube Assy	Tuyauterie	Conjunto de tubería
17	356269X1	1		1	Connector, Bulkhead	Passe-cloison	Pasatabiques
18	6109769M1	1		1	Bracket	Patte de fixation	Pata de fijación
19	339804X1	1	M6 x 25	2	Screw	Vis	Tornillo
20	390971X1	1	M6	2	Washer	Rondelle	Arandela
21	1441500X1	1	M6	2	Nut, Lock	Écrou de blocage	Tuerca de retención
22	6109770M1	1		1	Decal	Adhésif	Adhesivo
23	355575X1	1		2	Nut, Lock	Écrou de blocage	Tuerca de retención
24	6109768M91	1		1	Hose Assy	Ensemble de flexible	Flexible, Conj.
25	1862425M1	1		6	Tie, Cable	Attache câble	Enlace de Cable
26	355782X1	1		1	Plug, Blank-Off	Obturateur	Obturador
27	6110023M91	1		1	Tube Assy	Tuyauterie	Conjunto de tubería



860 880 970 980
 TX870B TX970B

811 812 815 816 823 824 843 853 854 923 932

98083C02.1

6199042M3

1

Jan-06

Auxiliary Hydraulics
Hydraulique Auxiliaire
Circuito hidráulico auxiliar

Centremount
Montage de Pelle Central
Excavadora de montaje central

Control Pedal
Pédale de Commande
Pedal de control

C-98083-03.1-A

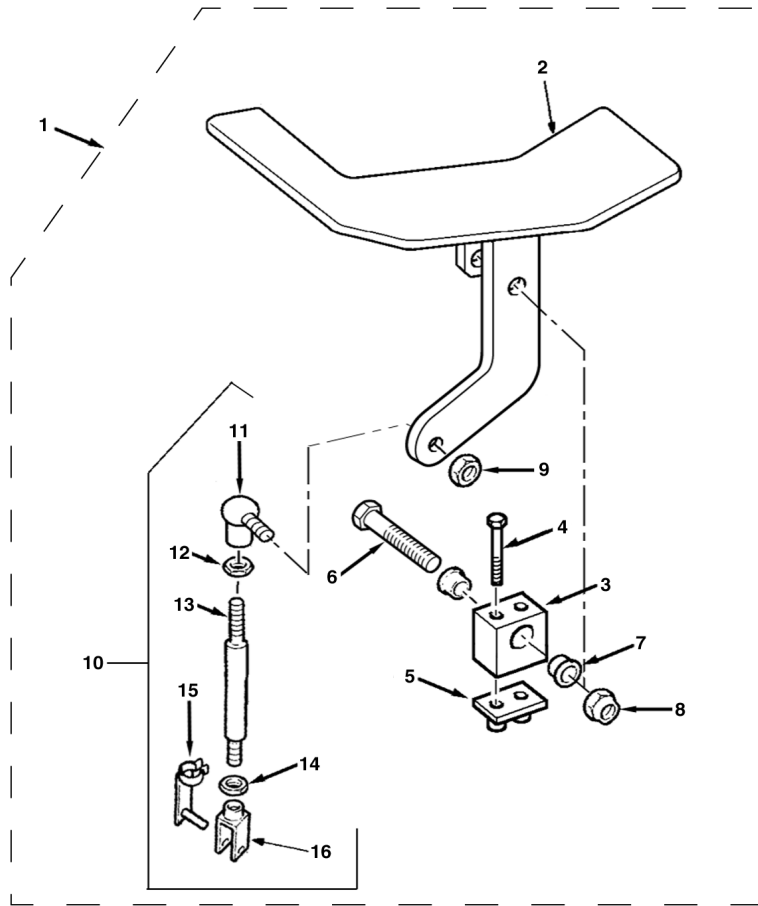

1	6110195M91		Continued CM Aux 4.9 Std Dipper	1	Kit, Installation	Colis d'installation	Juego de instalación
2	6106874M91	1		1	Pedal Assy	Ensemble de pédale	Pedal, Conj.
3	6106734M1	1		1	Pivot	Pivot	Pivote
4	3001758X1	1	M6 x 50	2	Screw	Vis	Tornillo
5	3519538M1	1		1	Plate, Base	Plaque de base	Placa de base
6	6106981M1	1	M10 x 60	1	Bolt	Boulon	Perno
7	6106866M1	1		2	Bushing	Bague	Anillo
8	1440329X1	1	M10	1	Nut, Lock	Écrou de blocage	Tuerca de retención
9	394367X1	1	M8	1	Nut, Lock	Écrou de blocage	Tuerca de retención
10	6106724M92	1		1	Rod Assy	Ensemble tringlerie	Tirantes, Conj.
11	3517518M1	10		1	Ball Joint	Rotule	Rotula
12	339169X1	10	M8	1	Nut	Écrou	Tuerca
13		10	➤ Ref.10	1	Rod	Tringle	Vástago
14	3519650M1	10	M8 LH Thread	1	Nut	Écrou	Tuerca
15	3520666M1	10		1	Pin, Clevis	Axe de chape	Eje de brida
16	3519590M1	10	LH Thread	1	Clevis	Chape	Brida
17	6101865M2	1		1	Decal	Adhésif	Adhesivo



860 880 970 980
 TX870B TX970B

811 812 815 816 823 824 843 853 854 923 932

98083C03.1

6199042M3

1

Jan-06

Auxiliary Hydraulics
Hydraulique Auxiliaire
Circuito hidráulico auxiliar

Sideshift
Montage de Pelle Latéral
Excavadora montaje horizontal

Telescopic Dipper
Balancier Télescopique
Balancín telescópico

C-98072-01.1-A

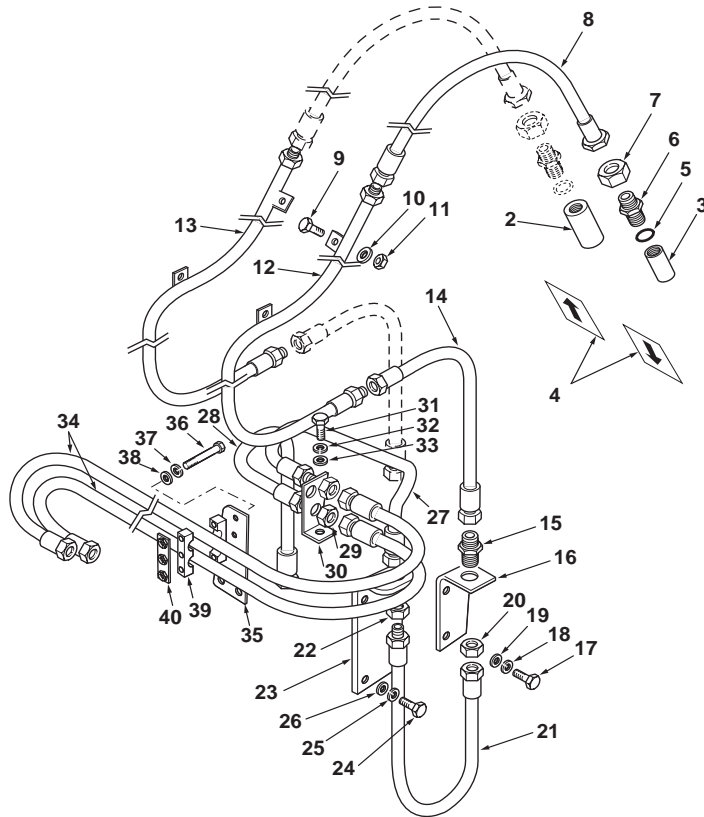

1	6110184M91		4.5 SS Aux with Extendahoe	1	Kit, Installation	Colis d'installation	Juego de instalación
2	3516796M91	1	Male	1	Coupler, Quick	Coupleur rapide	Acoplador rápido
3	3516797M91	1	Female	1	Coupler, Quick	Coupleur rapide	Acoplador rápido
4	6106080M1	1	Arrow	2	Decal	Adhésif	Adhesivo
5	835025M1	1		2	O-Ring	Joint torique	Junta de tipo O
6	356269X1	1		2	Connector, Bulkhead	Passe-cloison	Pasatabiques
7	355575X1	1		2	Nut, Lock	Écrou de blocage	Tuerca de retención
8	6106190M91	1		2	Hose Assy	Ensemble de flexible	Flexible, Conj.
9	339761X1	1	M8 x 25	4	Screw	Vis	Tornillo
10	390972X1	1	M8	4	Washer	Rondelle	Arandela
11	394367X1	1	M8	4	Nut, Lock	Écrou de blocage	Tuerca de retención
12	6106186M91	1	◀	1	Tube Assy	Tuyauterie	Conjunto de tubería
13	6106188M91	1	▶	1	Tube Assy	Tuyauterie	Conjunto de tubería
14	6106185M91	1		2	Hose Assy	Ensemble de flexible	Flexible, Conj.
15	356269X1	1		2	Connector, Bulkhead	Passe-cloison	Pasatabiques
16	6101964M1	1	◀	1	Bracket	Patte de fixation	Pata de fijación
16	6101965M1	1	▶	1	Bracket	Patte de fixation	Pata de fijación
17	339123X1	1	M8 x 20	4	Bolt	Boulon	Perno
18	339374X1	1	M8	4	Washer, Lock	Rondelle de blocage	Arandela de freno
19	390972X1	1	M8	4	Washer	Rondelle	Arandela
20	355575X1	1		2	Nut, Lock	Écrou de blocage	Tuerca de retención
21	6101899M91	1		2	Hose Assy	Ensemble de flexible	Flexible, Conj.
22	355575X1	1		2	Nut, Lock	Écrou de blocage	Tuerca de retención
23	6101459M91	1		2	Bracket	Patte de fixation	Pata de fijación
24	339123X1	1	M8 x 20	4	Bolt	Boulon	Perno
25	339374X1	1	M8	4	Washer, Lock	Rondelle de blocage	Arandela de freno
26	390972X1	1	M8	4	Washer	Rondelle	Arandela
27	6101461M92	1		1	Tube Assy	Tuyauterie	Conjunto de tubería
28	6101463M92	1		1	Tube Assy	Tuyauterie	Conjunto de tubería
29	355575X1	1		2	Nut, Lock	Écrou de blocage	Tuerca de retención
30	6101466M3	1		1	Bracket	Patte de fixation	Pata de fijación
31	3009493X1	1	M10 x 30	1	Bolt	Boulon	Perno
32	339376X1	1	M10	1	Washer, Lock	Rondelle de blocage	Arandela de freno
33	390734X1	1	M10	1	Washer	Rondelle	Arandela
34	6101898M91	1		2	Hose Assy	Ensemble de flexible	Flexible, Conj.
35	6102026M1	1		1	Plate	Plaque	Placa
36	339891X1	1	M8 x 80	3	Screw	Vis	Tornillo
37	339374X1	1	M8	3	Washer, Lock	Rondelle de blocage	Arandela de freno
38	390972X1	1	M8	3	Washer	Rondelle	Arandela
39	3522055M3	1		2	Bracket, Clamp	Bride de fixation	Brida de fijación
40	6102132M91	1		1	Plate	Plaque	Placa



820 860 880
 TX760B TX860B

805 807 817 825 833 845 855

98072C01.1

6199042M3

1

Jan-06

Auxiliary Hydraulics
Hydraulique Auxiliaire
Circuito hidráulico auxiliar

Sideshift
Montage de Pelle Latéral
Excavadora montaje horizontal

Telescopic Dipper
Balancier Téléscopique
Balancín telescópico

C-98072-02.1-A

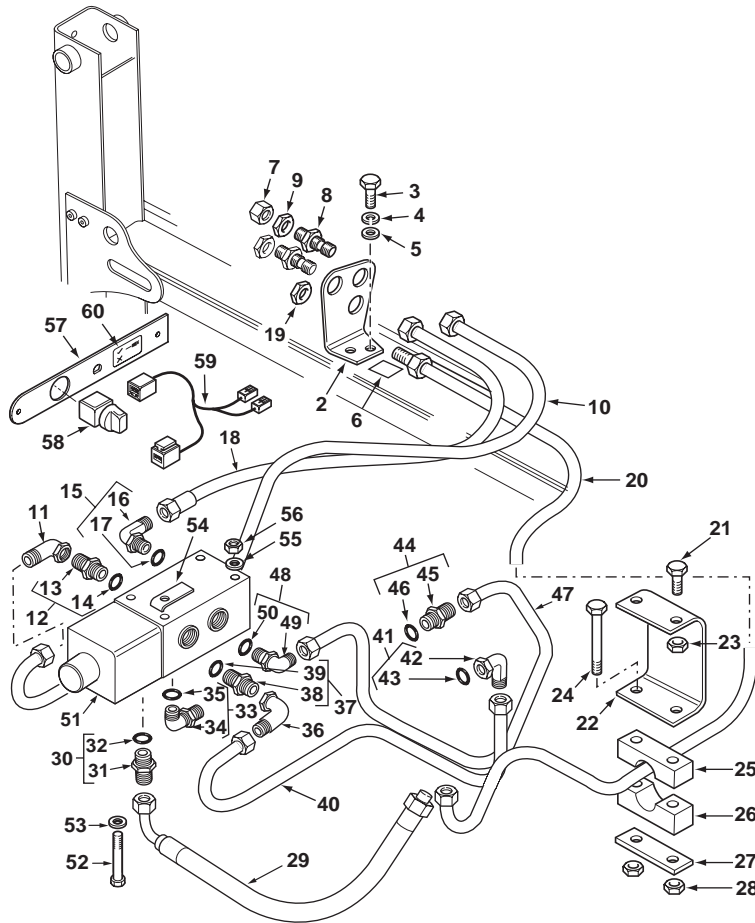

1	6110184M91		Continued 4.5 SS Aux with Extendahoe	1	Kit, Installation	Colis d'installation	Juego de instalación
2	6109873M1	1		1	Bracket	Patte de fixation	Pata de fijación
3	3009491X1	1	M10 x 20	2	Screw	Vis	Tornillo
4	339376X1	1	M10	2	Washer, Lock	Rondelle de blocage	Arandela de freno
5	390734X1	1	M10	2	Washer	Rondelle	Arandela
6	6109756M1	1		1	Decal	Adhésif	Adhesivo
7	355782X1	1		1	Plug, Blank-Off	Obturbateur	Obturador
8	356269X1	1		2	Connector, Bulkhead	Passe-cloison	Pasatabiques
9	355575X1	1		2	Nut, Lock	Écrou de blocage	Tuerca de retención
10	6109746M92	1		1	Tube Assy	Tuyauterie	Conjunto de tubería
11	366462X1	1		1	Elbow, 90°	Coude à 90°	Codo, 90°
12	835057M91	1		1	Connector Assy	Ensemble connexion	Conexión, Conj.
13		12	➡ Ref. 12	1	Connector	Connecteur	Conector
14	835025M1	12		1	O-Ring	Joint torique	Junta de tipo O
15	358764X91	1		1	Elbow, 90°	Coude à 90°	Codo, 90°
16		15	➡ Ref. 15	1	Elbow	Coude	Codo
17	835025M1	15		1	O-Ring	Joint torique	Junta de tipo O
18	6107408M93	1		1	Tube Assy	Tuyauterie	Conjunto de tubería
19	355575X1	1		1	Nut, Lock	Écrou de blocage	Tuerca de retención
20	6109846M91	1		1	Tube Assy	Tuyauterie	Conjunto de tubería
21	339666X1	1	M6 x 20	2	Screw	Vis	Tornillo
22	6109926M1	1		1	Bracket	Patte de fixation	Pata de fijación
23	1441500X1	1	M6	2	Nut, Lock	Écrou de blocage	Tuerca de retención
24	1440922X1	1	M6 x 60	2	Screw	Vis	Tornillo
25	3520340M3	1		1	Clamp	Collier de serrage	Argolla de cierre
26	1462584M1	1		1	Clamp	Collier de serrage	Argolla de cierre
27	1462583M1	1		1	Plate	Plaque	Placa
28	1441500X1	1	M6	2	Nut, Lock	Écrou de blocage	Tuerca de retención
29	6108513M91	1		1	Hose Assy	Ensemble de flexible	Flexible, Conj.
30	365715X91	1	1,1/16" - 7/8" UNF	1	Connector Assy	Ensemble connexion	Conexión, Conj.
31		30	➡ Ref. 30	1	Connector	Connecteur	Conector
32	835025M1	30		1	O-Ring	Joint torique	Junta de tipo O
33	368113X91	1		1	Elbow, 90°	Coude à 90°	Codo, 90°
34		33	➡ Ref. 33	1	Elbow	Coude	Codo
35	835025M1	33		1	O-Ring	Joint torique	Junta de tipo O
36	366462X1	1		1	Elbow, 90°	Coude à 90°	Codo, 90°
37	835057M91	1		1	Connector Assy	Ensemble connexion	Conexión, Conj.
38		37	➡ Ref. 37	1	Connector	Connecteur	Conector
39	835025M1	37		1	O-Ring	Joint torique	Junta de tipo O
40	6109622M91	1		1	Tube Assy	Tuyauterie	Conjunto de tubería
41	358764X91	1		1	Elbow, 90°	Coude à 90°	Codo, 90°
42		41	➡ Ref. 41	1	Elbow	Coude	Codo
43	835025M1	41		1	O-Ring	Joint torique	Junta de tipo O



820 860 880
 TX760B TX860B

805 807 817 825 833 845 855

98072C02.1

6199042M3

1

Jan-06

Auxiliary Hydraulics
Hydraulique Auxiliaire
Circuito hidráulico auxiliar

Sideshift
Montage de Pelle Latéral
Excavadora montaje horizontal

Telescopic Dipper
Balancier Téléscopique
Balancín telescópico

C-98072-02.1-A

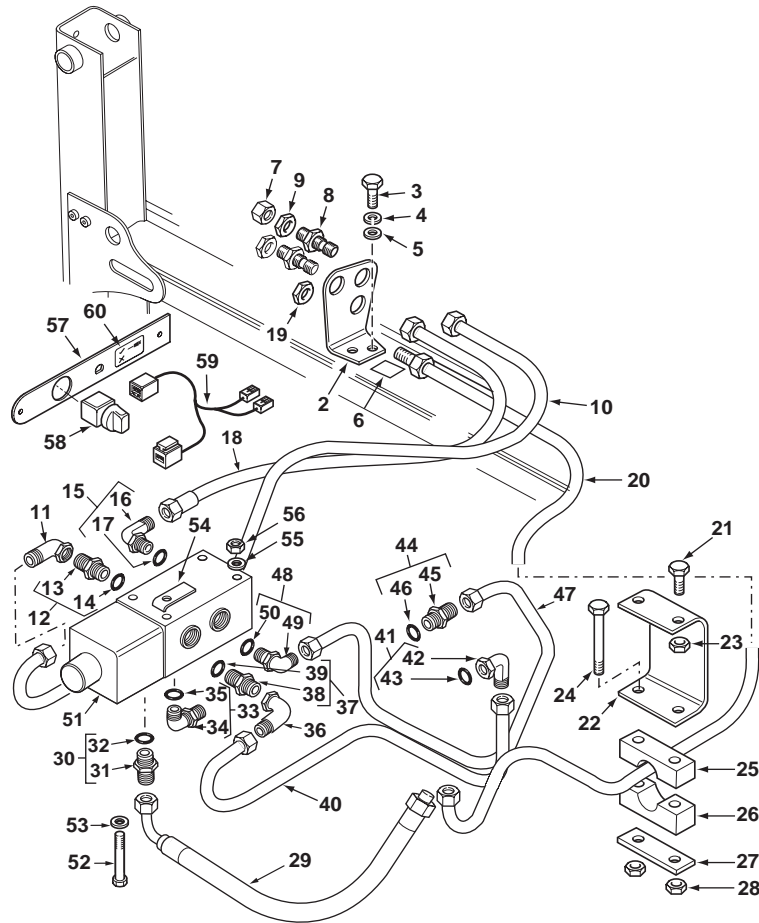

44	835057M91	1		1	Connector Assy	Ensemble connexion	Conexión, Conj.
45		44	➡ Ref. 44	1	Connector	Connecteur	Conector
46	835025M1	44		1	O-Ring	Joint torique	Junta de tipo O
47	6109620M91	1		1	Tube Assy	Tuyauterie	Conjunto de tubería
48	358764X91	1		1	Elbow, 90°	Coude à 90°	Codo, 90°
49		48	➡ Ref. 48	1	Elbow	Coude	Codo
50	835025M1	48		1	O-Ring	Joint torique	Junta de tipo O
51	6108292M91	1		1	Valve, Priority	Soupape de priorité	Válvula de prioridad
52	3019894X1	1	M6 x 100	3	Screw	Vis	Tornillo
53	3019571X1	1		3	Washer	Rondelle	Arandela
54	6108445M1	1		1	Bracket	Patte de fixation	Pata de fijación
55	390971X1	1	M6	3	Washer	Rondelle	Arandela
56	1441500X1	1	M6	3	Nut, Lock	Écrou de blocage	Tuerca de retención
57	6109934M1	1		1	Plate	Plaque	Placa
58	6107165M91	1		1	Switch Assy	Ensemble commutat.	Conmutador, Conj.
59	6107467M92	1		1	Harness Assy	Ensemble de faisceau	Haz, Conj.
60	6109932M1	1	Aux Hyds Switch	1	Decal	Adhésif	Adhesivo



820 860 880
 TX760B TX860B

805 807 817 825 833 845 855

98072C02.1

6199042M3

1

Jan-06

Auxiliary Hydraulics
Hydraulique Auxiliaire
Circuito hidráulico auxiliar

Sideshift
Montage de Pelle Latéral
Excavadora montaje horizontal

Telescopic Dipper
Balancier Télescopique
Balancín telescópico

Rops
Rops
Rops

C-98073-01.1-A

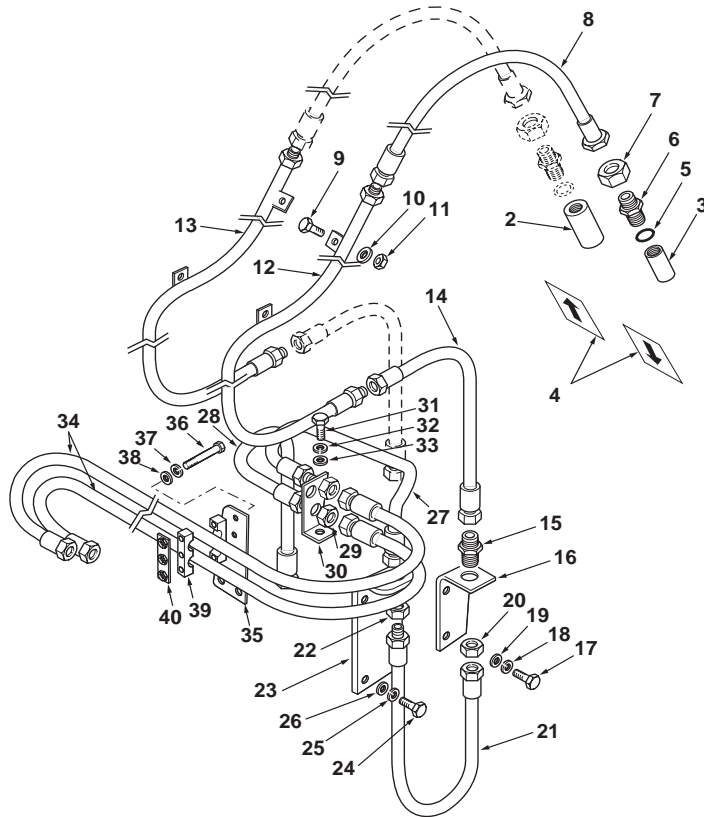

1	6110185M91		4.5 SS Aux with Extendahoe ROPS	1	Kit, Installation	Colis d'installation	Juego de instalación
2	3516796M91	1	Male	1	Coupler, Quick	Coupleur rapide	Acoplador rápido
3	3516797M91	1	Female	1	Coupler, Quick	Coupleur rapide	Acoplador rápido
4	6106080M1	1	Arrow	2	Decal	Adhésif	Adhesivo
5	835025M1	1		2	O-Ring	Joint torique	Junta de tipo O
6	356269X1	1		2	Connector, Bulkhead	Passe-cloison	Pasatabiques
7	355575X1	1		2	Nut, Lock	Écrou de blocage	Tuerca de retención
8	6106190M91	1		2	Hose Assy	Ensemble de flexible	Flexible, Conj.
9	339761X1	1	M8 x 25	4	Screw	Vis	Tornillo
10	390972X1	1	M8	4	Washer	Rondelle	Arandela
11	394367X1	1	M8	4	Nut, Lock	Écrou de blocage	Tuerca de retención
12	6106186M91	1	◀	1	Tube Assy	Tuyauterie	Conjunto de tubería
13	6106188M91	1	▶	1	Tube Assy	Tuyauterie	Conjunto de tubería
14	6106185M91	1		2	Hose Assy	Ensemble de flexible	Flexible, Conj.
15	356269X1	1		2	Connector, Bulkhead	Passe-cloison	Pasatabiques
16	6101964M1	1	◀	1	Bracket	Patte de fixation	Pata de fijación
16	6101965M1	1	▶	1	Bracket	Patte de fixation	Pata de fijación
17	339123X1	1	M8 x 20	4	Bolt	Boulon	Perno
18	339374X1	1	M8	4	Washer, Lock	Rondelle de blocage	Arandela de freno
19	390972X1	1	M8	4	Washer	Rondelle	Arandela
20	355575X1	1		2	Nut, Lock	Écrou de blocage	Tuerca de retención
21	6101899M91	1		2	Hose Assy	Ensemble de flexible	Flexible, Conj.
22	355575X1	1		2	Nut, Lock	Écrou de blocage	Tuerca de retención
23	6101459M91	1		2	Bracket	Patte de fixation	Pata de fijación
24	339123X1	1	M8 x 20	4	Bolt	Boulon	Perno
25	339374X1	1	M8	4	Washer, Lock	Rondelle de blocage	Arandela de freno
26	390972X1	1	M8	4	Washer	Rondelle	Arandela
27	6101461M92	1		1	Tube Assy	Tuyauterie	Conjunto de tubería
28	6101463M92	1		1	Tube Assy	Tuyauterie	Conjunto de tubería
29	355575X1	1		2	Nut, Lock	Écrou de blocage	Tuerca de retención
30	6101466M3	1		1	Bracket	Patte de fixation	Pata de fijación
31	3009493X1	1	M10 x 30	1	Bolt	Boulon	Perno
32	339376X1	1	M10	1	Washer, Lock	Rondelle de blocage	Arandela de freno
33	390734X1	1	M10	1	Washer	Rondelle	Arandela
34	6101898M91	1		2	Hose Assy	Ensemble de flexible	Flexible, Conj.
35	6102026M1	1		1	Plate	Plaque	Placa
36	339891X1	1	M8 x 80	3	Screw	Vis	Tornillo
37	339374X1	1	M8	3	Washer, Lock	Rondelle de blocage	Arandela de freno
38	390972X1	1	M8	3	Washer	Rondelle	Arandela
39	3522055M3	1		2	Bracket, Clamp	Bride de fixation	Brida de fijación
40	6102132M91	1		1	Plate	Plaque	Placa



820
TX760B

806 808 834

98073C01.1

6199042M3

1

Jan-06

Auxiliary Hydraulics
Hydraulique Auxiliaire
Circuito hidráulico auxiliar

Sideshift
Montage de Pelle Latéral
Excavadora montaje horizontal

Telescopic Dipper
Balancier Téléscopique
Balancín telescópico

Rops
Rops
Rops

C-98073-02.1-A

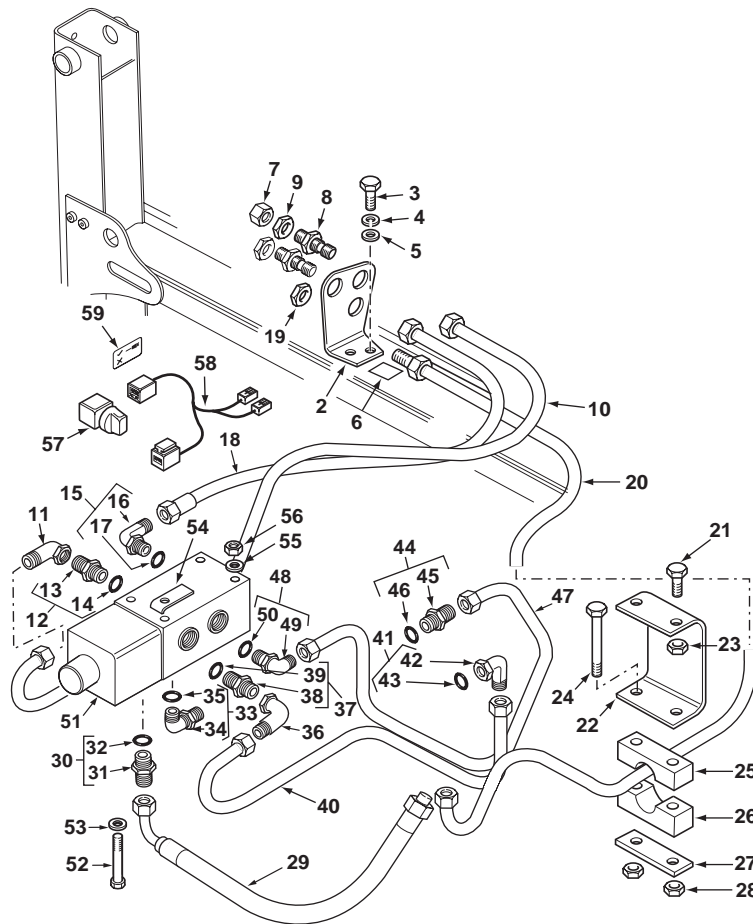

1	6110185M91		Continued 4.5 SS Aux with Extendahoe ROPS	1	Kit, Installation	Colis d'installation	Juego de instalación
2	6109873M1	1		1	Bracket	Patte de fixation	Pata de fijación
3	3009491X1	1	M10 x 20	2	Screw	Vis	Tornillo
4	339376X1	1	M10	2	Washer, Lock	Rondelle de blocage	Arandela de freno
5	390734X1	1	M10	2	Washer	Rondelle	Arandela
6	6109756M1	1		1	Decal	Adhésif	Adhesivo
7	355782X1	1		1	Plug, Blank-Off	Obturbateur	Obturator
8	356269X1	1		2	Connector, Bulkhead	Passe-cloison	Pasatabiques
9	355575X1	1		2	Nut, Lock	Écrou de blocage	Tuerca de retención
10	6109746M92	1		1	Tube Assy	Tuyauterie	Conjunto de tubería
11	366462X1	1		1	Elbow, 90°	Coude à 90°	Codo, 90°
12	835057M91	1		1	Connector Assy	Ensemble connexion	Conexión, Conj.
13		12	➡ Ref. 12	1	Connector	Connecteur	Conector
14	835025M1	12		1	O-Ring	Joint torique	Junta de tipo O
15	358764X91	1		1	Elbow, 90°	Coude à 90°	Codo, 90°
16		15	➡ Ref. 15	1	Elbow	Coude	Codo
17	835025M1	15		1	O-Ring	Joint torique	Junta de tipo O
18	6107408M93	1		1	Tube Assy	Tuyauterie	Conjunto de tubería
19	355575X1	1		1	Nut, Lock	Écrou de blocage	Tuerca de retención
20	6109846M91	1		1	Tube Assy	Tuyauterie	Conjunto de tubería
21	339666X1	1	M6 x 20	2	Screw	Vis	Tornillo
22	6109926M1	1		1	Bracket	Patte de fixation	Pata de fijación
23	1441500X1	1	M6	2	Nut, Lock	Écrou de blocage	Tuerca de retención
24	1440922X1	1	M6 x 60	2	Screw	Vis	Tornillo
25	3520340M3	1		1	Clamp	Collier de serrage	Argolla de cierre
26	1462584M1	1		1	Clamp	Collier de serrage	Argolla de cierre
27	1462583M1	1		1	Plate	Plaque	Placa
28	1441500X1	1	M6	2	Nut, Lock	Écrou de blocage	Tuerca de retención
29	6108513M91	1		1	Hose Assy	Ensemble de flexible	Flexible, Conj.
30	365715X91	1	1,1/16" - 7/8" UNF	1	Connector Assy	Ensemble connexion	Conexión, Conj.
31		30	➡ Ref. 30	1	Connector	Connecteur	Conector
32	835025M1	30		1	O-Ring	Joint torique	Junta de tipo O
33	368113X91	1		1	Elbow, 90°	Coude à 90°	Codo, 90°
34		33	➡ Ref. 33	1	Elbow	Coude	Codo
35	835025M1	33		1	O-Ring	Joint torique	Junta de tipo O
36	366462X1	1		1	Elbow, 90°	Coude à 90°	Codo, 90°
37	835057M91	1		1	Connector Assy	Ensemble connexion	Conexión, Conj.
38		37	➡ Ref. 37	1	Connector	Connecteur	Conector
39	835025M1	37		1	O-Ring	Joint torique	Junta de tipo O
40	6109622M91	1		1	Tube Assy	Tuyauterie	Conjunto de tubería
41	358764X91	1		1	Elbow, 90°	Coude à 90°	Codo, 90°
42		41	➡ Ref. 41	1	Elbow	Coude	Codo



820
TX760B

806 808 834

98073C02.1

6199042M3

1

Jan-06

Auxiliary Hydraulics
Hydraulique Auxiliaire
Circuito hidráulico auxiliar

Sideshift
Montage de Pelle Latéral
Excavadora montaje horizontal

Telescopic Dipper
Balancier Téléscopique
Balancín telescópico

Rops
Rops
Rops

C-98073-02.1-A

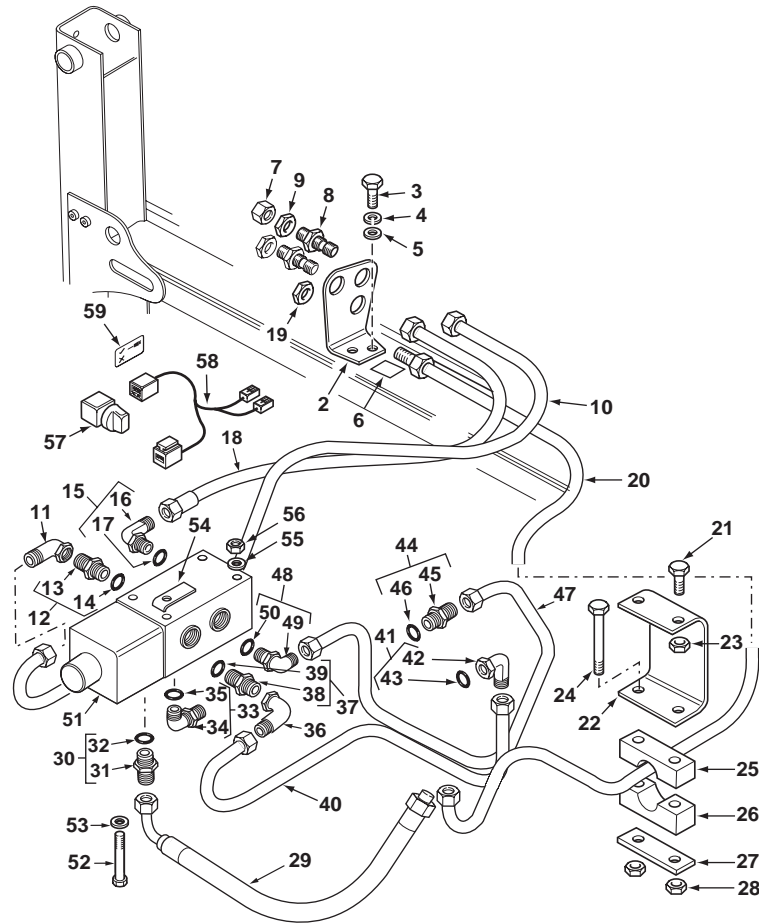

43	835025M1	41		1	O-Ring	Joint torique	Junta de tipo O
44	835057M91	1		1	Connector Assy	Ensemble connexion	Conexión, Conj.
45		44	➡ Ref. 44	1	Connector	Connecteur	Conector
46	835025M1	1		1	O-Ring	Joint torique	Junta de tipo O
47	6109620M91	1		1	Tube Assy	Tuyauterie	Conjunto de tubería
48	358764X91	1		1	Elbow, 90°	Coude à 90°	Codo, 90°
49		48	➡ Ref. 48	1	Elbow	Coude	Codo
50	835025M1	48		1	O-Ring	Joint torique	Junta de tipo O
51	6108292M91	1		1	Valve, Priority	Soupape de priorité	Válvula de prioridad
52	3019894X1	1	M6 x 100	3	Screw	Vis	Tornillo
53	3019571X1	1		3	Washer	Rondelle	Arandela
54	6108445M1	1		1	Bracket	Patte de fixation	Pata de fijación
55	390971X1	1	M6	3	Washer	Rondelle	Arandela
56	1441500X1	1	M6	3	Nut, Lock	Écrou de blocage	Tuerca de retención
57	6107165M91	1		1	Switch Assy	Ensemble commutat.	Conmutador, Conj.
58	6107467M92	1		1	Harness Assy	Ensemble de faisceau	Haz, Conj.
59	6109932M1	1	Aux Hyds Switch	1	Decal	Adhésif	Adhesivo



820
TX760B

806 808 834

98073C02.1

6199042M3

1

Jan-06

Auxiliary Hydraulics
Hydraulique Auxiliaire
Circuito hidráulico auxiliar

Sideshift
Montage de Pelle Latéral
Excavadora montaje horizontal

Telescopic Dipper
Balancier Télescopique
Balancín telescópico

4 Wheel Steer
4 Wheel Steer
4 Wheel Steer

C-98074-01.1-A

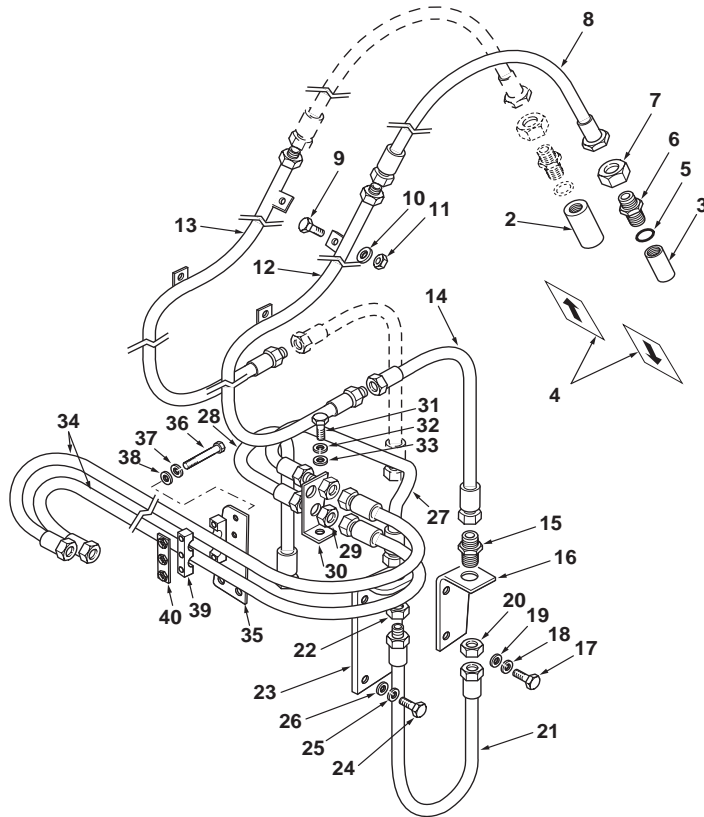

1	6110186M91		4.5 SS Aux with Extendahoe 4WS	1	Kit, Installation	Colis d'installation	Juego de instalación
2	3516796M91	1	Male	1	Coupler, Quick	Coupleur rapide	Acoplador rápido
3	3516797M91	1	Female	1	Coupler, Quick	Coupleur rapide	Acoplador rápido
4	6106080M1	1	Arrow	2	Decal	Adhésif	Adhesivo
5	835025M1	1		2	O-Ring	Joint torique	Junta de tipo O
6	356269X1	1		2	Connector, Bulkhead	Passe-cloison	Pasatabiques
7	355575X1	1		2	Nut, Lock	Écrou de blocage	Tuerca de retención
8	6106190M91	1		2	Hose Assy	Ensemble de flexible	Flexible, Conj.
9	339761X1	1	M8 x 25	4	Screw	Vis	Tornillo
10	390972X1	1	M8	4	Washer	Rondelle	Arandela
11	394367X1	1	M8	4	Nut, Lock	Écrou de blocage	Tuerca de retención
12	6106186M91	1	◀	1	Tube Assy	Tuyauterie	Conjunto de tubería
13	6106188M91	1	▶	1	Tube Assy	Tuyauterie	Conjunto de tubería
14	6106185M91	1		2	Hose Assy	Ensemble de flexible	Flexible, Conj.
15	356269X1	1		2	Connector, Bulkhead	Passe-cloison	Pasatabiques
16	6101964M1	1	◀	1	Bracket	Patte de fixation	Pata de fijación
16	6101965M1	1	▶	1	Bracket	Patte de fixation	Pata de fijación
17	339123X1	1	M8 x 20	4	Bolt	Boulon	Perno
18	339374X1	1	M8	4	Washer, Lock	Rondelle de blocage	Arandela de freno
19	390972X1	1	M8	4	Washer	Rondelle	Arandela
20	355575X1	1		2	Nut, Lock	Écrou de blocage	Tuerca de retención
21	6101899M91	1		2	Hose Assy	Ensemble de flexible	Flexible, Conj.
22	355575X1	1		2	Nut, Lock	Écrou de blocage	Tuerca de retención
23	6101459M91	1		2	Bracket	Patte de fixation	Pata de fijación
24	339123X1	1	M8 x 20	4	Bolt	Boulon	Perno
25	339374X1	1	M8	4	Washer, Lock	Rondelle de blocage	Arandela de freno
26	390972X1	1	M8	4	Washer	Rondelle	Arandela
27	6101461M92	1		1	Tube Assy	Tuyauterie	Conjunto de tubería
28	6101463M92	1		1	Tube Assy	Tuyauterie	Conjunto de tubería
29	355575X1	1		2	Nut, Lock	Écrou de blocage	Tuerca de retención
30	6101466M3	1		1	Bracket	Patte de fixation	Pata de fijación
31	3009493X1	1	M10 x 30	1	Bolt	Boulon	Perno
32	339376X1	1	M10	1	Washer, Lock	Rondelle de blocage	Arandela de freno
33	390734X1	1	M10	1	Washer	Rondelle	Arandela
34	6101898M91	1		2	Hose Assy	Ensemble de flexible	Flexible, Conj.
35	6102026M1	1		1	Plate	Plaque	Placa
36	339891X1	1	M8 x 80	3	Screw	Vis	Tornillo
37	339374X1	1	M8	3	Washer, Lock	Rondelle de blocage	Arandela de freno
38	390972X1	1	M8	3	Washer	Rondelle	Arandela
39	3522055M3	1		2	Bracket, Clamp	Bride de fixation	Brida de fijación
40	6102132M91	1		1	Plate	Plaque	Placa



970 980

921 931

98074C01.1

6199042M3

1

Jan-06

Auxiliary Hydraulics
Hydraulique Auxiliaire
Circuito hidráulico auxiliar

Sideshift
Montage de Pelle Latéral
Excavadora montaje horizontal

Telescopic Dipper
Balancier Téléscopique
Balancín telescópico

4 Wheel Steer
 4 Wheel Steer
 4 Wheel Steer

C-98074-02.1-A

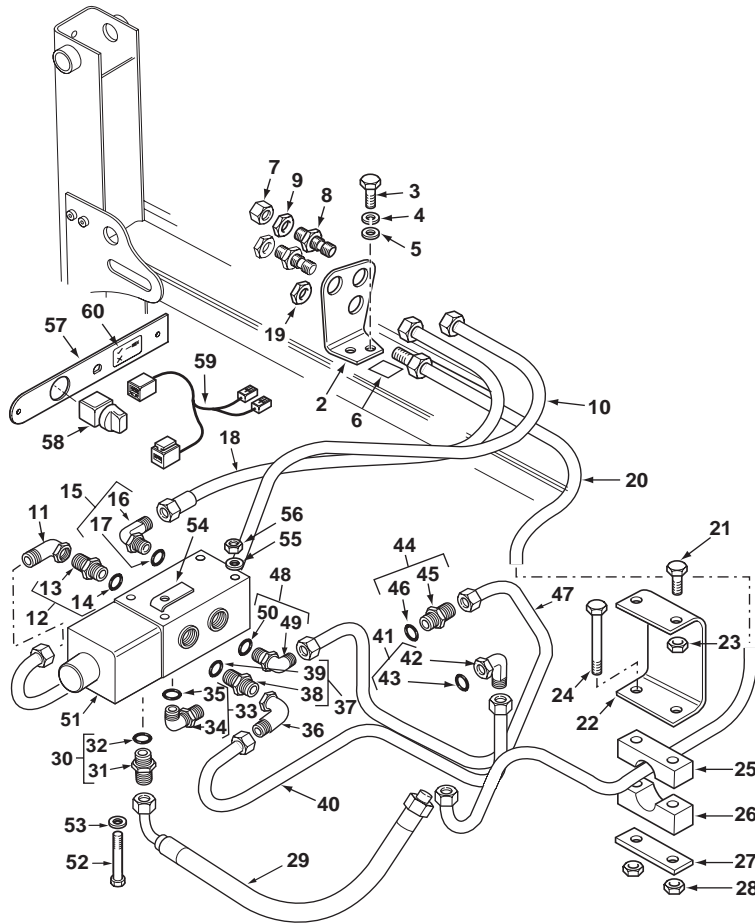

1	6110186M91		Continued 4.5 SS Aux with Extendahoe 4WS	1	Kit, Installation	Colis d'installation	Juego de instalación
2	6109873M1	1		1	Bracket	Patte de fixation	Pata de fijación
3	3009491X1	1	M10 x 20	2	Screw	Vis	Tornillo
4	339376X1	1	M10	2	Washer, Lock	Rondelle de blocage	Arandela de freno
5	390734X1	1	M10	2	Washer	Rondelle	Arandela
6	6109756M1	1		1	Decal	Adhésif	Adhesivo
7	355782X1	1		1	Plug, Blank-Off	Obturbateur	Obturador
8	356269X1	1		2	Connector, Bulkhead	Passe-cloison	Pasatabiques
9	355575X1	1		2	Nut, Lock	Écrou de blocage	Tuerca de retención
10	6109746M92	1		1	Tube Assy	Tuyauterie	Conjunto de tubería
11	366462X1	1		1	Elbow, 90°	Coude à 90°	Codo, 90°
12	835057M91	1		1	Connector Assy	Ensemble connexion	Conexión, Conj.
13		12	➡ Ref. 12	1	Connector	Connecteur	Conector
14	835025M1	12		1	O-Ring	Joint torique	Junta de tipo O
15	358764X91	1		1	Elbow, 90°	Coude à 90°	Codo, 90°
16		15	➡ Ref. 15	1	Elbow	Coude	Codo
17	835025M1	15		1	O-Ring	Joint torique	Junta de tipo O
18	6107408M93	1		1	Tube Assy	Tuyauterie	Conjunto de tubería
19	355575X1	1		1	Nut, Lock	Écrou de blocage	Tuerca de retención
20	6109846M91	1		1	Tube Assy	Tuyauterie	Conjunto de tubería
21	339666X1	1	M6 x 20	2	Screw	Vis	Tornillo
22	6109926M1	1		1	Bracket	Patte de fixation	Pata de fijación
23	1441500X1	1	M6	2	Nut, Lock	Écrou de blocage	Tuerca de retención
24	1440922X1	1	M6 x 60	2	Screw	Vis	Tornillo
25	3520340M3	1		1	Clamp	Collier de serrage	Argolla de cierre
26	1462584M1	1		1	Clamp	Collier de serrage	Argolla de cierre
27	1462583M1	1		1	Plate	Plaque	Placa
28	1441500X1	1	M6	2	Nut, Lock	Écrou de blocage	Tuerca de retención
29	6108513M91	1		1	Hose Assy	Ensemble de flexible	Flexible, Conj.
30	365715X91	1	1,1/16" - 7/8" UNF	1	Connector Assy	Ensemble connexion	Conexión, Conj.
31		30	➡ Ref. 30	1	Connector	Connecteur	Conector
32	835025M1	30		1	O-Ring	Joint torique	Junta de tipo O
33	368113X91	1		1	Elbow, 90°	Coude à 90°	Codo, 90°
34		33	➡ Ref. 33	1	Elbow	Coude	Codo
35	835025M1	33		1	O-Ring	Joint torique	Junta de tipo O
36	366462X1	1		1	Elbow, 90°	Coude à 90°	Codo, 90°
37	835057M91	1		1	Connector Assy	Ensemble connexion	Conexión, Conj.
38		37	➡ Ref. 37	1	Connector	Connecteur	Conector
39	835025M1	37		1	O-Ring	Joint torique	Junta de tipo O
40	6109622M91	1		1	Tube Assy	Tuyauterie	Conjunto de tubería
41	358764X91	1		1	Elbow, 90°	Coude à 90°	Codo, 90°
42		41	➡ Ref. 41	1	Elbow	Coude	Codo
43	835025M1	41		1	O-Ring	Joint torique	Junta de tipo O



970 980

921 931

98074C02.1

6199042M3

1

Jan-06

Auxiliary Hydraulics
Hydraulique Auxiliaire
Circuito hidráulico auxiliar

Sideshift
Montage de Pelle Latéral
Excavadora montaje horizontal

Telescopic Dipper
Balancier Téléscopique
Balancín telescópico

4 Wheel Steer
 4 Wheel Steer
 4 Wheel Steer

C-98074-02.1-A

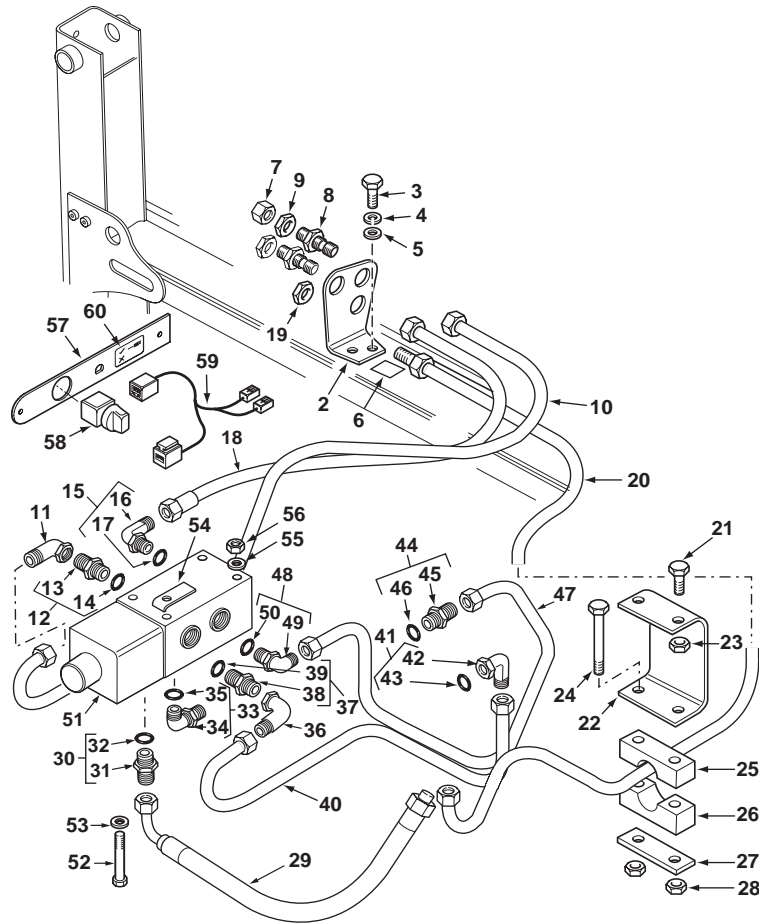

44	835057M91	1		1	Connector Assy	Ensemble connexion	Conexión, Conj.
45		44	➡ Ref. 44	1	Connector	Connecteur	Conector
46	835025M1	44		1	O-Ring	Joint torique	Junta de tipo O
47	6109620M91	1		1	Tube Assy	Tuyauterie	Conjunto de tubería
48	358764X91	1		1	Elbow, 90°	Coude à 90°	Codo, 90°
49		48	➡ Ref. 48	1	Elbow	Coude	Codo
50	835025M1	48		1	O-Ring	Joint torique	Junta de tipo O
51	6108292M91	1		1	Valve, Priority	Soupape de priorité	Válvula de prioridad
52	3019894X1	1	M6 x 100	3	Screw	Vis	Tornillo
53	3019571X1	1		3	Washer	Rondelle	Arandela
54	6108445M1	1		1	Bracket	Patte de fixation	Pata de fijación
55	390971X1	1	M6	3	Washer	Rondelle	Arandela
56	1441500X1	1	M6	3	Nut, Lock	Écrou de blocage	Tuerca de retención
57	6110013M1	1		1	Plate	Plaque	Placa
58	6107165M91	1		1	Switch Assy	Ensemble commutat.	Conmutador, Conj.
59	6107467M92	1		1	Harness Assy	Ensemble de faisceau	Haz, Conj.
60	6109933M1	1	Aux Hyds Switch	1	Decal	Adhésif	Adhesivo



970 980

921 931

98074C02.1

6199042M3

1

Jan-06

Auxiliary Hydraulics
Hydraulique Auxiliaire
Circuito hidráulico auxiliar

Sideshift
Montage de Pelle Latéral
Excavadora montaje horizontal

Standard Dipper
Balancier Standard
Balancín estándar

C-98081-01.1-A

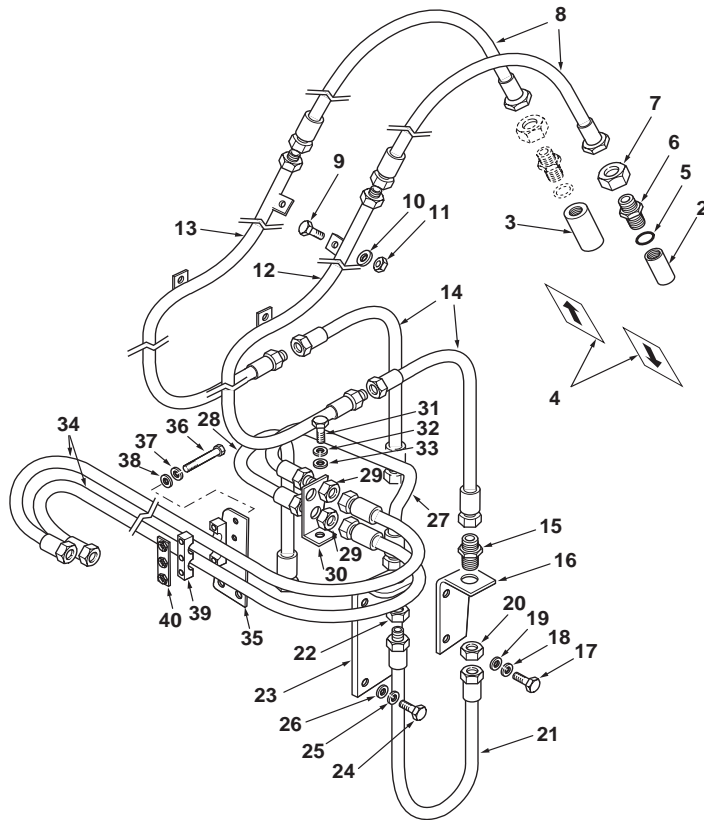

1	6110193M91		SS Aux with Std Dipper	1	Kit, Installation	Colis d'installation	Juego de instalación
2	3516796M91	1	Male	1	Coupler, Quick	Coupleur rapide	Acoplador rápido
3	3516797M91	1	Female	1	Coupler, Quick	Coupleur rapide	Acoplador rápido
4	6106080M1	1	Arrow	2	Decal	Adhésif	Adhesivo
5	835025M1	1		2	O-Ring	Joint torique	Junta de tipo O
6	356269X1	1		2	Connector, Bulkhead	Passe-cloison	Pasatabiques
7	355575X1	1		2	Nut, Lock	Écrou de blocage	Tuerca de retención
8	6106190M91	1		2	Hose Assy	Ensemble de flexible	Flexible, Conj.
9	339761X1	1	M8 x 25	4	Screw	Vis	Tornillo
10	390972X1	1	M8	4	Washer	Rondelle	Arandela
11	394367X1	1	M8	4	Nut, Lock	Écrou de blocage	Tuerca de retención
12	6106186M91	1	◀	1	Tube Assy	Tuyauterie	Conjunto de tubería
13	6106188M91	1	▶	1	Tube Assy	Tuyauterie	Conjunto de tubería
14	6106185M91	1		2	Hose Assy	Ensemble de flexible	Flexible, Conj.
15	356269X1	1		2	Connector, Bulkhead	Passe-cloison	Pasatabiques
16	6101964M1	1	◀	1	Bracket	Patte de fixation	Pata de fijación
16	6101965M1	1	▶	1	Bracket	Patte de fixation	Pata de fijación
17	339123X1	1	M8 x 20	4	Bolt	Boulon	Perno
18	339374X1	1	M8	4	Washer, Lock	Rondelle de blocage	Arandela de freno
19	390972X1	1	M8	4	Washer	Rondelle	Arandela
20	355575X1	1		2	Nut, Lock	Écrou de blocage	Tuerca de retención
21	6101899M91	1		2	Hose Assy	Ensemble de flexible	Flexible, Conj.
22	355575X1	1		2	Nut, Lock	Écrou de blocage	Tuerca de retención
23	6101459M91	1		2	Bracket	Patte de fixation	Pata de fijación
24	339123X1	1	M8 x 20	4	Bolt	Boulon	Perno
25	339374X1	1	M8	4	Washer, Lock	Rondelle de blocage	Arandela de freno
26	390972X1	1	M8	4	Washer	Rondelle	Arandela
27	6101461M92	1		1	Tube Assy	Tuyauterie	Conjunto de tubería
28	6101463M92	1		1	Tube Assy	Tuyauterie	Conjunto de tubería
29	355575X1	1		2	Nut, Lock	Écrou de blocage	Tuerca de retención
30	6101466M3	1		1	Bracket	Patte de fixation	Pata de fijación
31	3009493X1	1	M10 x 30	1	Bolt	Boulon	Perno
32	339376X1	1	M10	1	Washer, Lock	Rondelle de blocage	Arandela de freno
33	390734X1	1	M10	1	Washer	Rondelle	Arandela
34	6101898M91	1		2	Hose Assy	Ensemble de flexible	Flexible, Conj.
35	6102026M1	1		1	Plate	Plaque	Placa
36	339891X1	1	M8 x 80	3	Screw	Vis	Tornillo
37	339374X1	1	M8	3	Washer, Lock	Rondelle de blocage	Arandela de freno
38	390972X1	1	M8	3	Washer	Rondelle	Arandela
39	3522055M3	1		2	Bracket, Clamp	Bride de fixation	Brida de fijación
40	6102132M91	1		1	Plate	Plaque	Placa



820 860 880 970 980
 TX760B TX860B

805 806 807 808 817 825 833 834 845 855 921 931

98081C01.1

6199042M3

1

Jan-06

Auxiliary Hydraulics
Hydraulique Auxiliaire
Circuito hidráulico auxiliar

Sideshift
Montage de Pelle Latéral
Excavadora montaje horizontal

Standard Dipper
Balancier Standard
Balancín estándar

C-98081-02.1-A

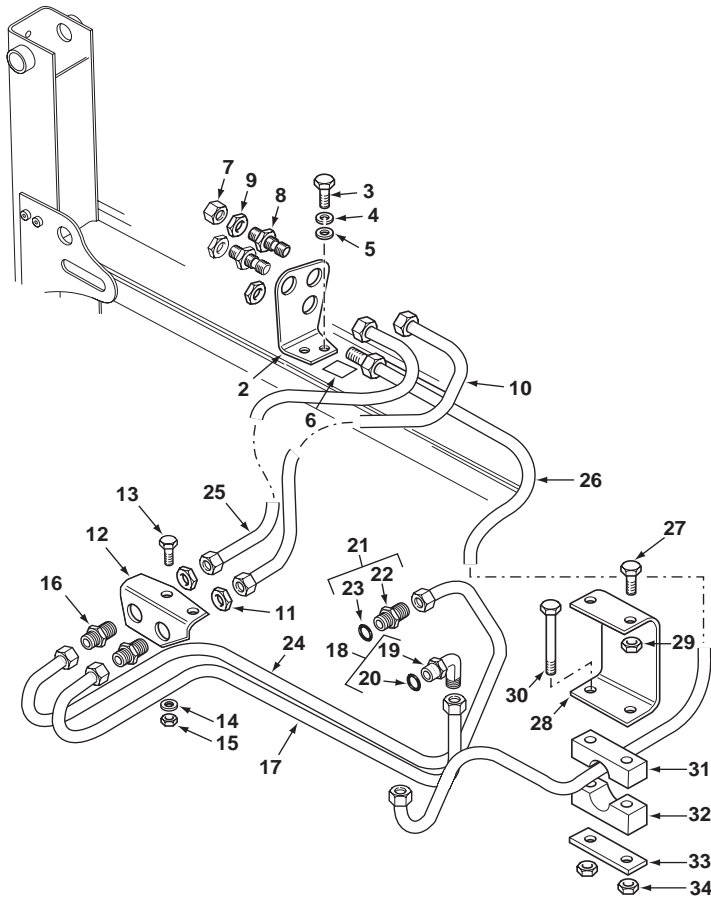

1	6110193M91		Continued SS Aux with Std Dipper	1	Kit, Installation	Colis d'installation	Juego de instalación
2	6109873M1	1		1	Bracket	Patte de fixation	Pata de fijación
3	3009491X1	1	M10 x 20	2	Screw	Vis	Tornillo
4	339376X1	1	M10	2	Washer, Lock	Rondelle de blocage	Arandela de freno
5	390734X1	1	M10	2	Washer	Rondelle	Arandela
6	6109756M1	1		1	Decal	Adhésif	Adhesivo
7	355782X1	1		1	Plug, Blank-Off	Obturbateur	Obturador
8	356269X1	1		2	Connector, Bulkhead	Passe-cloison	Pasatabiques
9	355575X1	1		2	Nut, Lock	Écrou de blocage	Tuerca de retención
10	6110029M92	1		1	Tube Assy	Tuyauterie	Conjunto de tubería
11	355575X1	1		2	Nut, Lock	Écrou de blocage	Tuerca de retención
12	6110076M1	1		1	Bracket	Patte de fixation	Pata de fijación
13	339804X1	1	M6 x 25	2	Screw	Vis	Tornillo
14	390971X1	1	M6	2	Washer	Rondelle	Arandela
15	1441500X1	1	M6	2	Nut, Lock	Écrou de blocage	Tuerca de retención
16	356269X1	1		2	Connector, Bulkhead	Passe-cloison	Pasatabiques
17	6110031M91	1		1	Tube Assy	Tuyauterie	Conjunto de tubería
18	358764X91	1		1	Elbow, 90°	Coude à 90°	Codo, 90°
19		18	➡ Ref. 18	1	Elbow	Coude	Codo
20	835025M1	18		1	O-Ring	Joint torique	Junta de tipo O
21	835057M91	1		1	Connector Assy	Ensemble connexion	Conexión, Conj.
22		21	➡ Ref. 21	1	Connector	Connecteur	Conector
23	835025M1	21		1	O-Ring	Joint torique	Junta de tipo O
24	6110077M91	1		1	Tube Assy	Tuyauterie	Conjunto de tubería
25	6107408M93	1		1	Tube Assy	Tuyauterie	Conjunto de tubería
26	6109846M91	1		1	Tube Assy	Tuyauterie	Conjunto de tubería
27	339666X1	1	M6 x 20	2	Screw	Vis	Tornillo
28	6109926M1	1		1	Bracket	Patte de fixation	Pata de fijación
29	1441500X1	1	M6	2	Nut, Lock	Écrou de blocage	Tuerca de retención
30	1440922X1	1	M6 x 60	2	Screw	Vis	Tornillo
31	3520340M3	1		1	Clamp	Collier de serrage	Argolla de cierre
32	1462584M1	1		1	Clamp	Collier de serrage	Argolla de cierre
33	1462583M1	1		1	Plate	Plaque	Placa
34	1441500X1	1	M6	2	Nut, Lock	Écrou de blocage	Tuerca de retención



820 860 880 970 980
 TX760B TX860B

805 806 807 808 817 825 833 834 845 855 921 931

98081C02.1

6199042M3

1

Jan-06

Auxiliary Hydraulics
Hydraulique Auxiliaire
Circuito hidráulico auxiliar

Sideshift
Montage de Pelle Latéral
Excavadora montaje horizontal

Control Pedal
Pédale de Commande
Pedal de control

C-98081-03.1-A

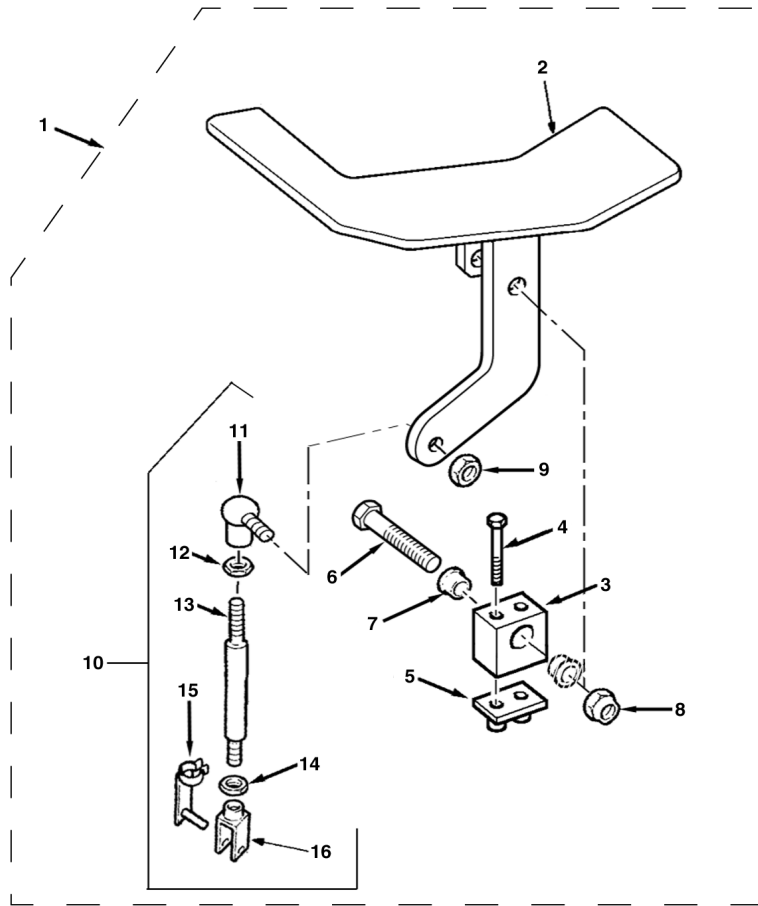

1	6110193M91		Continued SS Aux with Std Dipper	1	Kit, Installation	Colis d'installation	Juego de instalación
2	6106874M91	1		1	Pedal Assy	Ensemble de pédale	Pedal, Conj.
3	6106734M1	1		1	Pivot	Pivot	Pivote
4	3001758X1	1	M6 x 50	2	Screw	Vis	Tornillo
5	3519538M1	1		1	Plate, Base	Plaque de base	Placa de base
6	6106981M1	1	M10 x 60	1	Bolt	Boulon	Perno
7	6106866M1	1		2	Bushing	Bague	Anillo
8	1440329X1	1	M10	1	Nut, Lock	Écrou de blocage	Tuerca de retención
9	394367X1	1	M8	1	Nut, Lock	Écrou de blocage	Tuerca de retención
10	6106724M92	1		1	Rod Assy	Ensemble tringlerie	Tirantes, Conj.
11	3517518M1	10		1	Ball Joint	Rotule	Rotula
12	339169X1	10	M8	1	Nut	Écrou	Tuerca
13		10	➡ Ref.10	1	Rod	Tringle	Vástago
14	3519650M1	10	LH Thread M8 LH Thread	1	Nut	Écrou	Tuerca
15	3520666M1	10		1	Pin, Clevis	Axe de chape	Eje de brida
16	3519590M1	10	LH Thread LH Thread	1	Clevis	Chape	Brida



820 860 880 970 980
 TX760B TX860B

805 806 807 808 817 825 833 834 845 855 921 931

98081C03.1

6199042M3

1

Jan-06

Bucket Blade Kit
Coffret de Lame de Godet
Juego de cuchilla de cuchara

Wide
 Large
 Ancha

AC-98012-01.1-A

1	ACC41B		Continued Bucket & Blade	1	Accessory code	Code accessoire	Código accesorio
1	ACC42B		Continued Bucket & Blade	1	Accessory code	Code accessoire	Código accesorio
2	3517383M2	1	2386 mm	1	Edge, Cutting	Lame d'attaque	Cuchilla de ataque
3	3009480X1	1	M16 x 60	16	Screw	Vis	Tornillo
4	339034X1	1	M16	16	Nut	Écrou	Tuerca

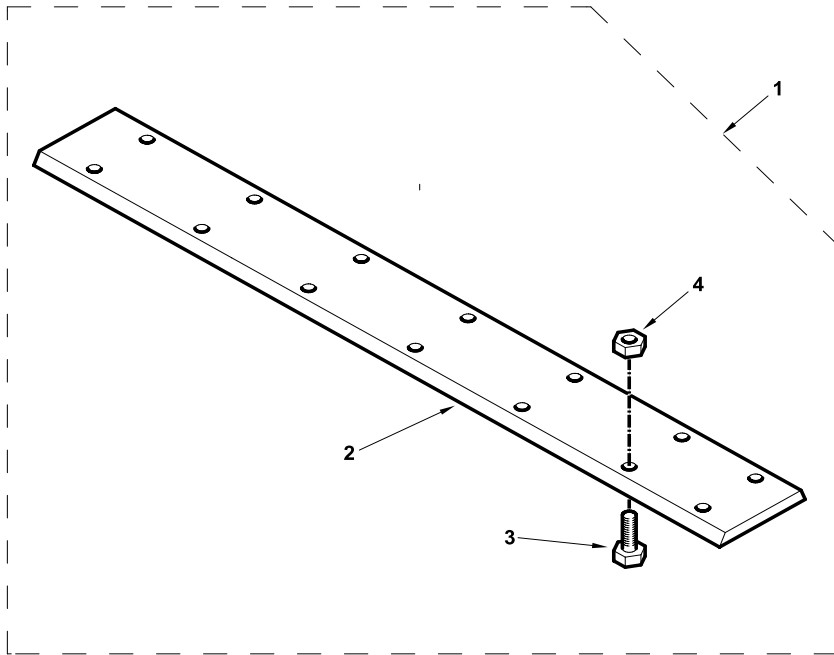

860 880 970 980
 TX860B TX870B
 TX970B

809 810 811 812 813 814 815 816 817 821 822 823 824 825 841 842 843 844 845
 851 852 853 854 855 921 922 923 931 932

98012AC01.1

6199042M3

1

Jan-06

Bucket Blade Kit
Coffret de Lame de Godet
Juego de cuchilla de cuchara

Wide
 Large
 Ancha

C-98012-01.1-A

1	3517383M2	2386 mm	1	Edge, Cutting	Lame d'attaque	Cuchilla de ataque
2	3009480X1	M16 x 60	16	Screw	Vis	Tornillo
3	339034X1	M16	16	Nut	Écrou	Tuerca

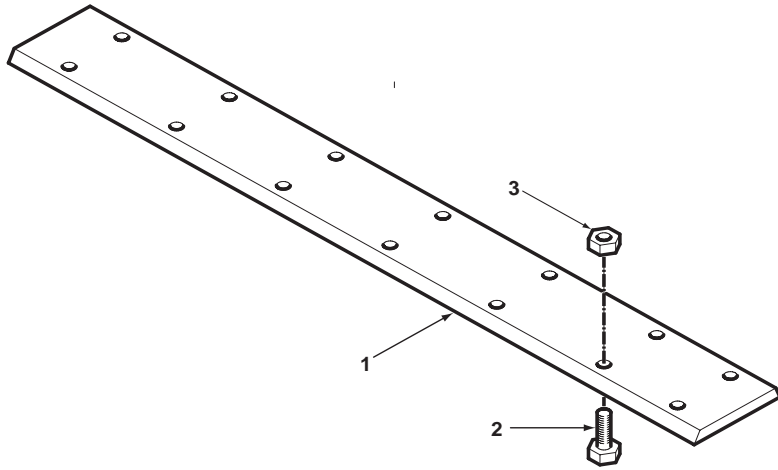

860 880 970 980
 TX860B TX870B
 TX970B

809 810 811 812 813 814 815 816 817 821 822 823 824 825 841 842 843 844 845
 851 852 853 854 855 921 922 923 931 932

98012C01.1

6199042M3

1

Jan-06

Bucket Blade Kit
Coffret de Lame de Godet
Juego de cuchilla de cuchara

Narrow
 Étroite
 Estrecha

AC-98013-01.1-A

1	ACC41A		Continued Bucket & Blade	1	Accessory code	Code accessoire	Código accesorio
1	ACC42A		Continued Bucket & Blade	1	Accessory code	Code accessoire	Código accesorio
2	6106228M1	1	2310 mm	1	Edge, Cutting	Lame d'attaque	Cuchilla de ataque
3	3009480X1	1	M16 x 60	16	Screw	Vis	Tornillo
4	339034X1	1	M16	16	Nut	Écrou	Tuerca

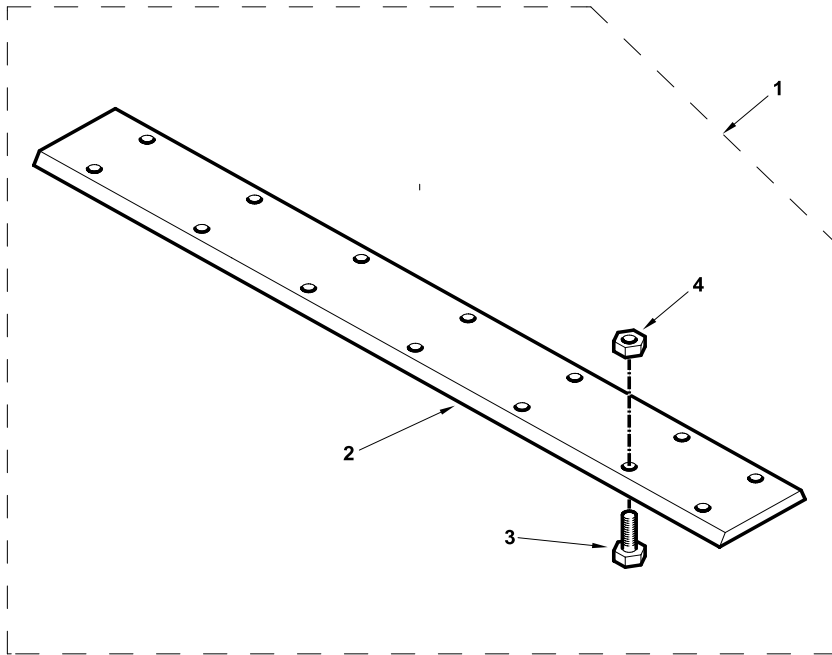

820 860 880
 TX760B TX860B
 TX870B

801 802 803 804 805 806 807 808 809 810 811 812 813 814 815 816 817 821 822
 823 824 825 831 832 833 834 841 842 843 844 845 851 852 853 854 855

98013AC01.1

6199042M3

1

Jan-06

Bucket Blade Kit
Coffret de Lame de Godet
Juego de cuchilla de cuchara

Narrow
 Étroite
 Estrecha

C-98013-01.1-A

1	6106228M1	2310 mm	1	Edge, Cutting	Lame d'attaque	Cuchilla de ataque
2	3009480X1	M16 x 60	16	Screw	Vis	Tornillo
3	339034X1	M16	16	Nut	Écrou	Tuerca

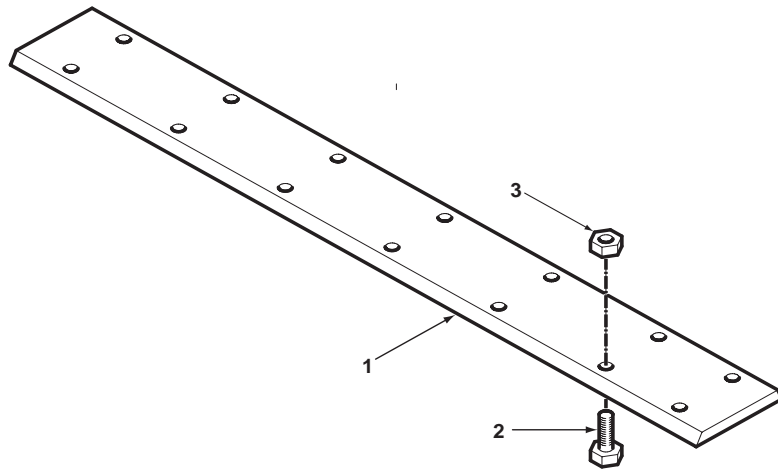

820 860 880
 TX760B TX860B
 TX870B

801 802 803 804 805 806 807 808 809 810 811 812 813 814 815 816 817 821 822
 823 824 825 831 832 833 834 841 842 843 844 845 851 852 853 854 855

98013C01.1

6199042M3

1

Jan-06

Bucket Pins Kit
Coffret de Goupilles de Godet
Juego de pasador de cuchara

Single
 Simple
 Simple

C-98006-01.1-A

1	3516519M94	45 x 302 mm	2	Pin	Axe	Pasador
2	3516522M91		2	Pin, Linch	Goupille d'arrêt	Pasador de parada
3	3501790M1		2	Washer	Rondelle	Arandela

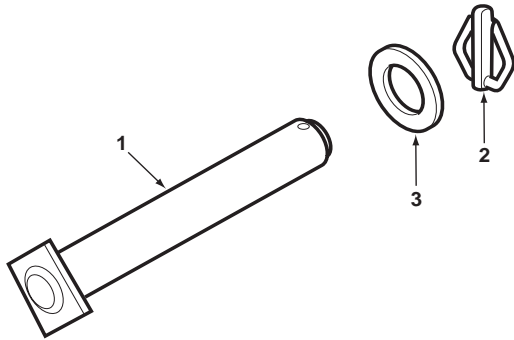

820 860 880 970 980
 TX760B TX860B
 TX870B TX970B

801 802 803 804 805 806 807 808 813 814 815 816 817 821 822 823 824 825 831
 832 833 834 841 842 843 844 845 851 852 853 854 855 921 922 923 931 932

Bucket Pins Kit
 Coffret de Goupilles de Godet
 Juego de pasador de cuchara

Double
 Double
 Doble

C-98007-01.1-A

1	3516519M94	45 x 302 mm	4	Pin	Axe	Pasador
2	3516522M91		4	Pin, Linch	Goupille d'arrêt	Pasador de parada
3	3501790M1		4	Washer	Rondelle	Arandela

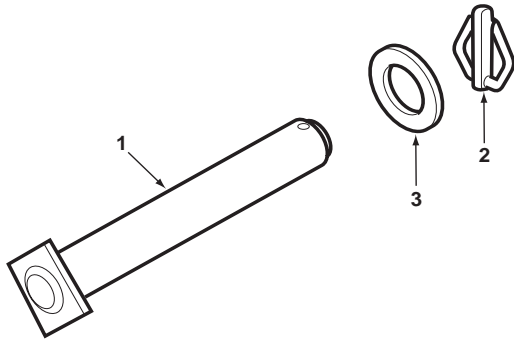

820 860 880 970 980
 TX760B TX860B
 TX870B TX970B

801 802 803 804 805 806 807 808 813 814 815 816 817 821 822 823 824 825 831
 832 833 834 841 842 843 844 845 851 852 853 854 855 921 922 923 931 932

98007C01.1

6199042M3

1

Jan-06

Bucket Tooth Kit
Coffret de Dent de Godet
Juego de diente de cuchara

Standard Loader Bucket
Godet Chargeur Standard
Cuchara cargadora estándar

AC-98010-01.1-A

1	ACC18A			1	Accessory code	Code accessoire	Código accesorio
2	1462201M3	1		8	Tooth	Dent	Diente
3	862738M1	1	0,8 mm	16	Shim	Cale	Calce
4	862739M1	1	1,6 mm	16	Shim	Cale	Calce
5	353915X1	1	5/8" UNF x 2.62"	8	Bolt	Boulon	Perno
6	353427X1	1	5/8" UNF	8	Nut	Écrou	Tuerca

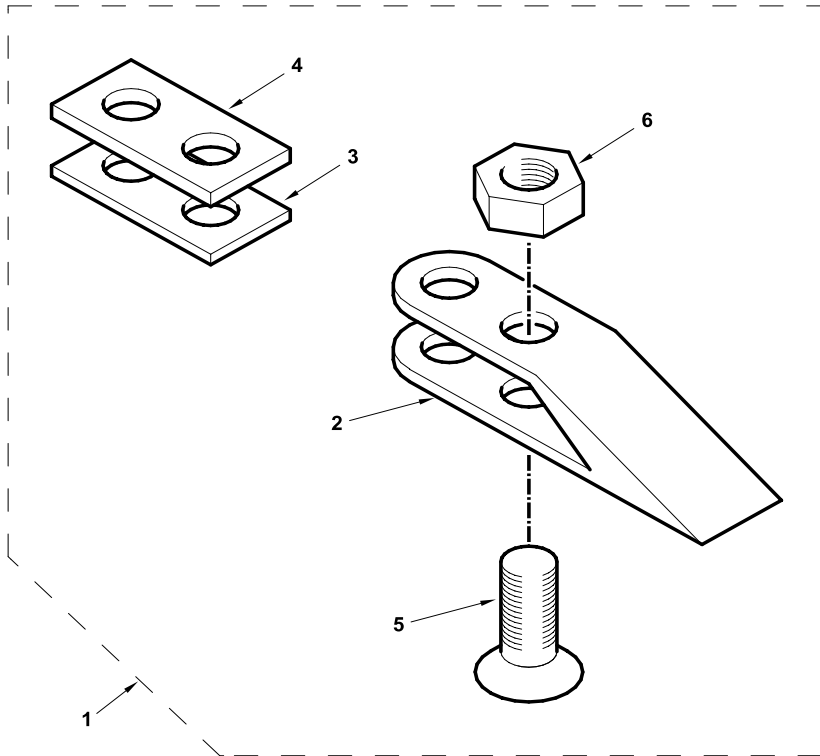

820 860 880
 TX760B TX860B
 TX870B

801 802 803 804 805 806 807 808 809 810 811 812 813 814 815 816 817 821 822
 823 824 825 831 832 833 834 841 842 843 844 845 851 852 853 854 855

Bucket Tooth Kit
Coffret de Dent de Godet
Juego de diente de cuchara

Standard Loader Bucket
Godet Chargeur Standard
Cuchara cargadora estándar

C-98010-01.1-A

1	1462201M3		8	Tooth	Dent	Diente
2	862738M1	0,8 mm	16	Shim	Cale	Calce
3	862739M1	1,6 mm	16	Shim	Cale	Calce
4	353915X1	5/8" UNF x 2.62"	8	Bolt	Boulon	Perno
5	353427X1	5/8" UNF	8	Nut	Écrou	Tuerca

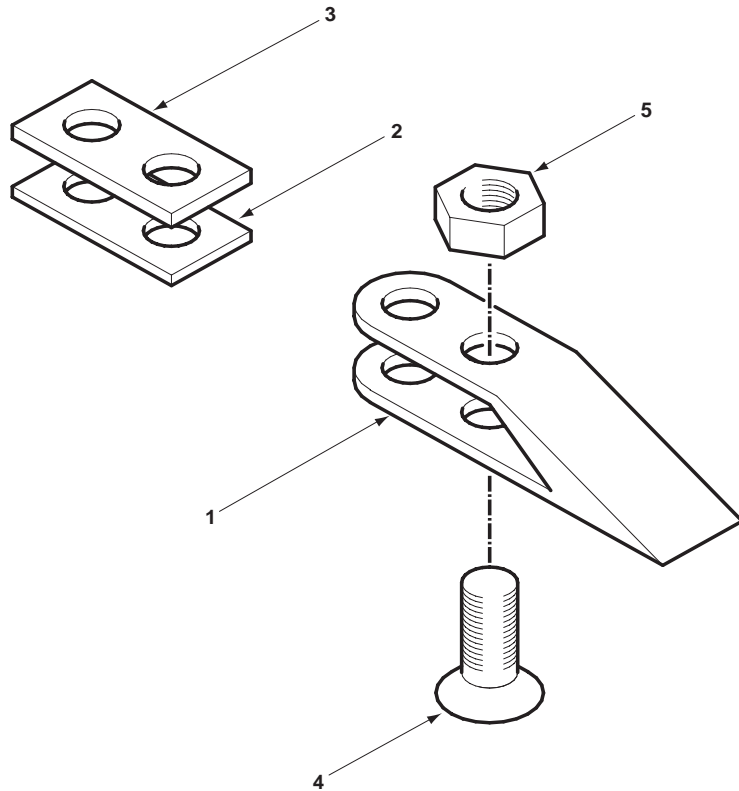

820 860 880
 TX760B TX860B
 TX870B

801 802 803 804 805 806 807 808 809 810 811 812 813 814 815 816 817 821 822
 823 824 825 831 832 833 834 841 842 843 844 845 851 852 853 854 855

98010C01.1

6199042M3

1

Jan-06

Bucket Tooth Kit
Coffret de Dent de Godet
Juego de diente de cuchara

Loader Bucket, 7-In-1
Godet Chargeur 7-en-1
Cuchara cargadora 7 x 1

AC-98011-01.1-A

1	ACC18B			1	Accessory code	Code accessoire	Código accesorio
2	1462201M3	1		8	Tooth	Dent	Diente
3	3519698M1	1		8	Pad, Wear	Patin d'usure	Patin de desgaste
4	353427X1	1	5/8" UNF	16	Nut	Écrou	Tuerca
5	353915X1	1	5/8" UNF x 2.62"	16	Bolt	Boulon	Perno

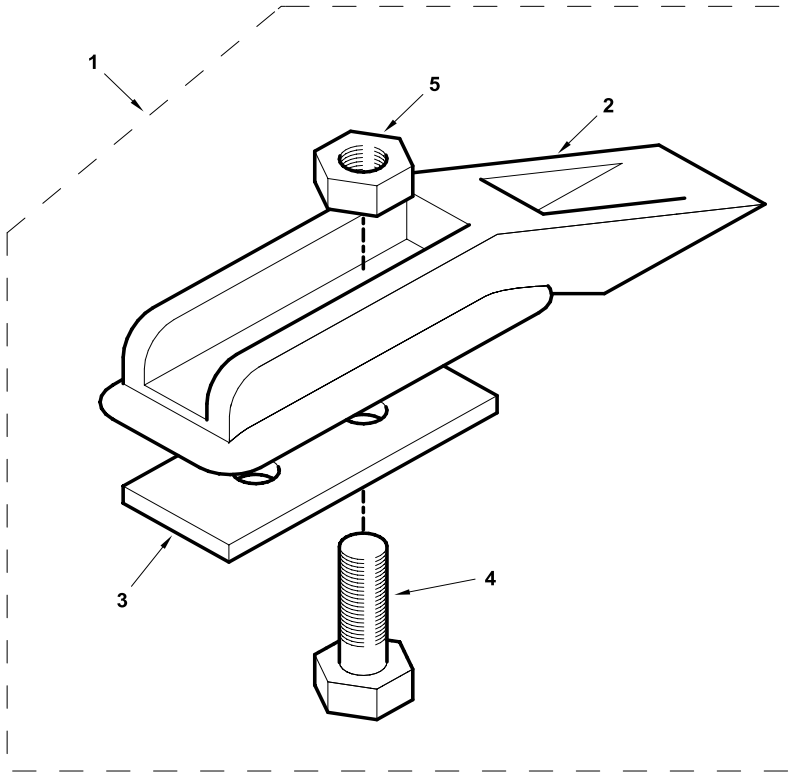

820 860 880 970 980
 TX760B TX860B
 TX870B TX970B

801 802 803 804 805 806 807 808 809 810 811 812 813 814 815 816 817 821 822
 823 824 825 831 832 833 834 841 842 843 844 845 851 852 853 854 855 921 922
 923 931 932

98011AC01.1

6199042M3

1

Jan-06

Bucket Tooth Kit
Coffret de Dent de Godet
Juego de diente de cuchara

Loader Bucket, 7-In-1
Godet Chargeur 7-en-1
Cuchara cargadora 7 x 1

C-98011-01.1-A

1	1462201M3		8	Tooth	Dent	Diente
2	3519698M1		8	Pad, Wear	Patin d'usure	Patín de desgaste
3	353427X1	5/8" UNF	16	Nut	Écrou	Tuerca
4	353915X1	5/8" UNF x 2.62"	16	Bolt	Boulon	Perno

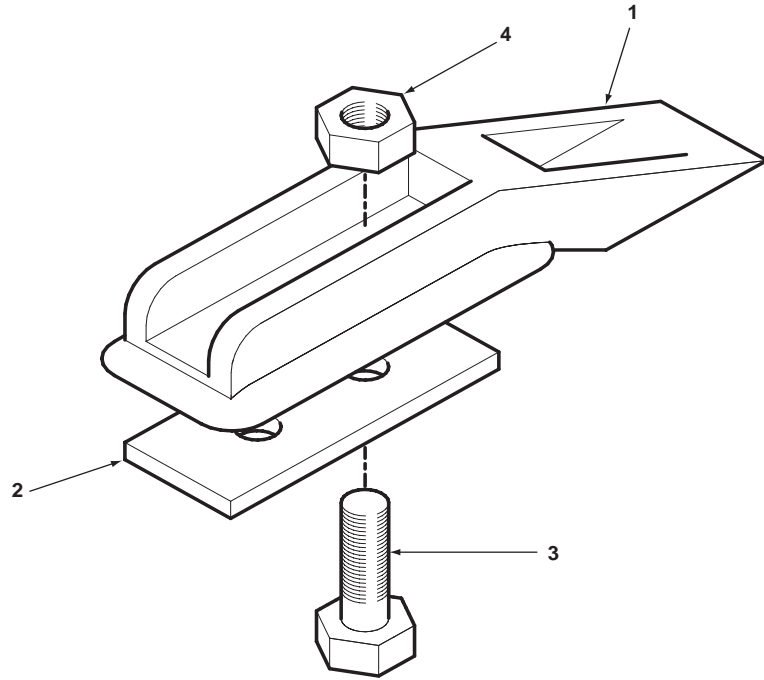

820 860 880 970 980
 TX760B TX860B
 TX870B TX970B

801 802 803 804 805 806 807 808 809 810 811 812 813 814 815 816 817 821 822
 823 824 825 831 832 833 834 841 842 843 844 845 851 852 853 854 855 921 922
 923 931 932

CD/Radio Player
CD/Radio
Reproductor de CD/Radio

C-98134-01.1-A

1	6110609M91		1	CD/Radio	CD/Radio	CD/Radio
---	------------	--	---	----------	----------	----------

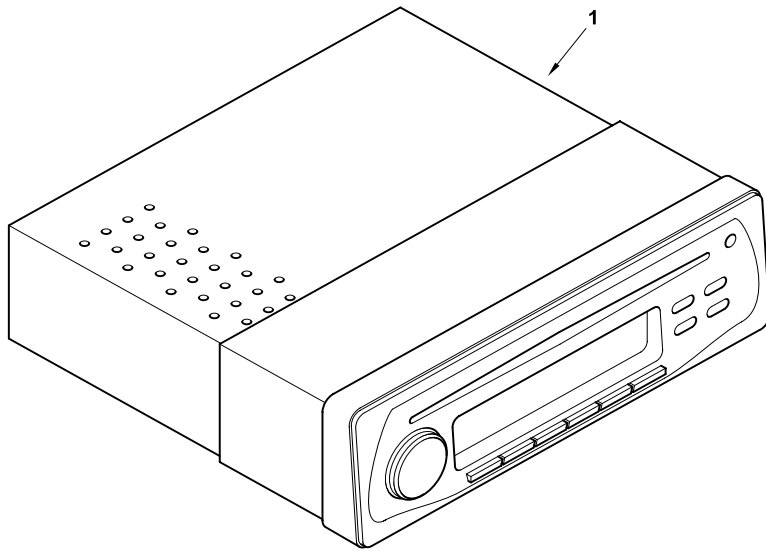

880 980
TX760B TX860B
TX870B TX970B

831 833 841 843 845 851 853 855 931 932

98134C01.1

6199042M3

1

Jan-06

Craning Valve Kit
Coffret de Distributeur de Commande
Manutention
Juego de distribuidor de mando de
mantenimiento

Cab
 Cabine
 Cabina

C-98002-01.1-A

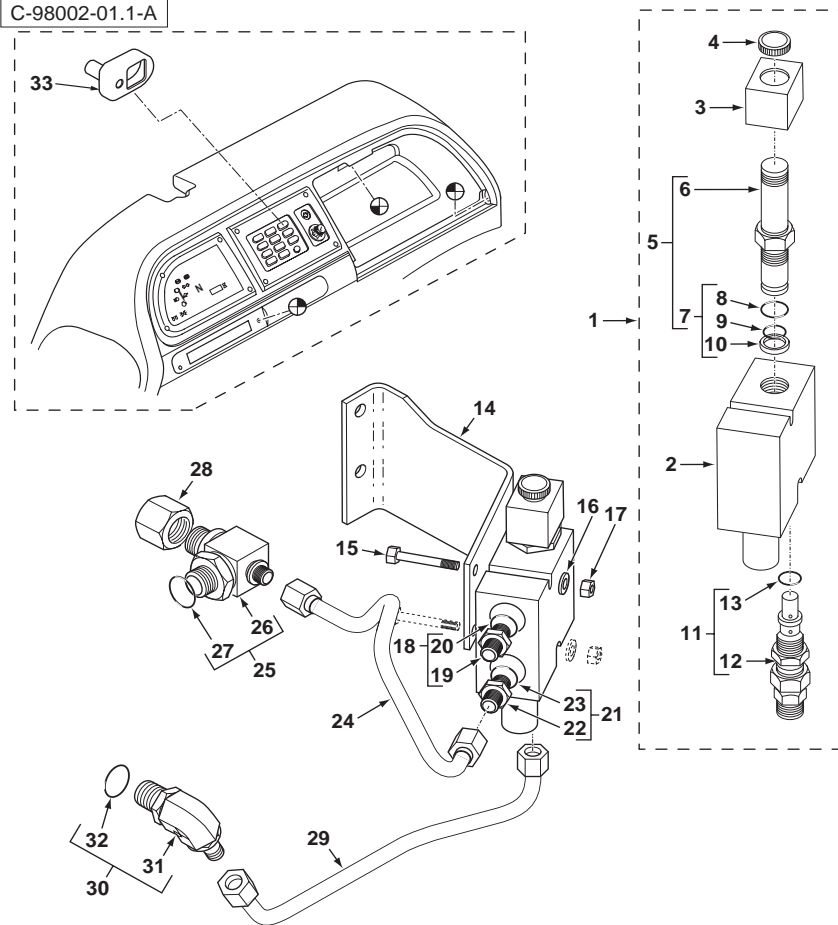

1	6102082M92		1	Valve, Solenoid	Électrovalve	Electroválvula
2		1	▶ Ref. 1	Body	Corps	Cuerpo
3	6191096M91	1	▶ 12V	Coil	Bobine	Bobina
4		1	▶ Ref. 1	Nut	Écrou	Tuerca
5	6190777M91	1		Spool	Tiroir	Cajoncillo
6		5	▶ Ref. 5	Spool	Tiroir	Cajoncillo
7	6190778M91	5		Kit, Seal	Pochette de joints	Juego de juntas
8		7	▶ Ref. 7	O-Ring	Joint torique	Junta de tipo O
9		7	▶ Ref. 7	O-Ring	Joint torique	Junta de tipo O
10		7	▶ Ref. 7	Ring, Backup	Contre-joint	ContraJunta
11	6193287M91	1	▶ 395 Bar	Valve, Press. Relief	Soupape de sécurité	Válvula de seguridad
12		11	▶ Ref. 11	Valve	Soupape	Válvula
13	6190780M91	11		Kit, Seal	Pochette de joints	Juego de juntas
14	6109357M1			Bracket	Patte de fixation	Pata de fijación
15	390246X1	M8 x 70		Bolt	Boulon	Perno
16	390972X1	M8		Washer	Rondelle	Arandela
17	394367X1	M8		Nut, Lock	Écrou de blocage	Tuerca de retención
18	365715X91	1,1/16" - 7/8" UNF		Connector Assy	Ensemble connexion	Conexión, Conj.
19		18	▶ Ref. 18	Connector	Connecteur	Conector
20	835025M1	18		O-Ring	Joint torique	Junta de tipo O
21	358743X91	3/4"		Union	Union	Unión
22		21	▶ Ref. 21	Connector	Connecteur	Conector
23	831497M1	21		O-Ring	Joint torique	Junta de tipo O
24	6109433M91			Tube Assy	Tuyauterie	Conjunto de tubería
25	3521700M91			Tee	Raccord en T	Te
26		25	▶ Ref. 25	Tee	Raccord en T	Te
27	835025M1	25		O-Ring	Joint torique	Junta de tipo O
28	356582X1			Cap	Chapeau	Sombbrero
29	6109435M91			Tube Assy	Tuyauterie	Conjunto de tubería
30	368113X91			Elbow, 90°	Coude à 90°	Codo, 90°
31		30	▶ Ref. 30	Elbow	Coude	Codo
32	835025M1	30		O-Ring	Joint torique	Junta de tipo O
33	6101777M91		▶ Switch	Cover	Cache	Tapa



820 860 880 970 980
 TX760B TX860B
 TX870B TX970B

801 803 809 811 813 815 821 823 831 841 843 851 853 922 923 932

98002C01.1

6199042M3

1

Jan-06

Craning Valve Kit
Coffret de Distributeur de Commande
Manutention
Juego de distribuidor de mando de
mantenimiento

4 Post ROPS
 4 Poteau ROPS
 4 poste ROPS

C-98003-01.1-A

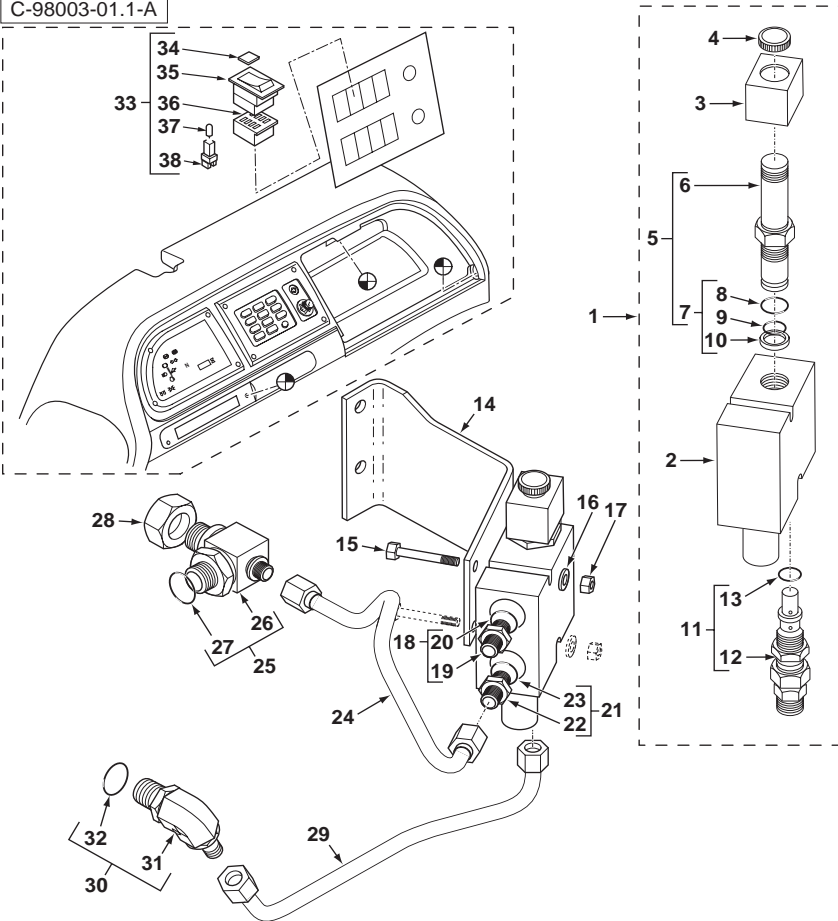

1	6102082M92		1	Valve, Solenoid	Électrovalve	Electroválvula
2		1	Ref. 1	Body	Corps	Cuerpo
3	6191096M91	1	12V	Coil	Bobine	Bobina
4		1	Ref. 1	Nut	Écrou	Tuerca
5	6190777M91	1		Spool	Tiroir	Cajoncillo
6		5	Ref. 5	Spool	Tiroir	Cajoncillo
7	6190778M91	5		Kit, Seal	Pochette de joints	Juego de juntas
8		7	Ref. 7	O-Ring	Joint torique	Junta de tipo O
9		7	Ref. 7	O-Ring	Joint torique	Junta de tipo O
10		7	Ref. 7	Ring, Backup	Contre-joint	ContraJunta
11	6193287M91	1	395 Bar	Valve, Press. Relief	Soupape de sécurité	Válvula de seguridad
12		11	Ref. 11	Valve	Soupape	Válvula
13	6190780M91	11		Kit, Seal	Pochette de joints	Juego de juntas
14	6109357M1			Bracket	Patte de fixation	Pata de fijación
15	390246X1		M8 x 70	Bolt	Boulon	Perno
16	390972X1		M8	Washer	Rondelle	Arandela
17	394367X1		M8	Nut, Lock	Écrou de blocage	Tuerca de retención
18	365715X91		1,1/16" - 7/8" UNF	Connector Assy	Ensemble connexion	Conexión, Conj.
19		18	Ref. 18	Connector	Connecteur	Conector
20	835025M1	18		O-Ring	Joint torique	Junta de tipo O
21	358743X91		3/4"	Union	Union	Unión
22		21	Ref. 21	Connector	Connecteur	Conector
23	831497M1	21		O-Ring	Joint torique	Junta de tipo O
24	6109433M91			Tube Assy	Tuyauterie	Conjunto de tubería
25	3521700M91			Tee	Raccord en T	Te
26		25	Ref. 25	Tee	Raccord en T	Te
27	835025M1	25		O-Ring	Joint torique	Junta de tipo O
28	356582X1			Cap	Chapeau	Sombbrero
29	6109435M91			Tube Assy	Tuyauterie	Conjunto de tubería
30	368113X91			Elbow, 90°	Coude à 90°	Codo, 90°
31		30	Ref. 30	Elbow	Coude	Codo
32	835025M1	30		O-Ring	Joint torique	Junta de tipo O
33	3521579M93			Switch Assy	Ensemble commutat.	Conmutador, Conj.
34	3512504M1			Emblem	Emblème	Emblema
35	6000046M91			Switch	Contacteur	Contactar
36		33	Ref. 33	Housing	Carter	Cárter
37	3523562M1		12V 1.2W	Bulb	Lampe	Lámpara
38		33		Holder	Porte-injecteur	Retén



820 860 880
 TX760B TX860B
 TX870B

802 804 810 812 814 816 822 824 832 842 844 852 854

98003C01.1

6199042M3

1

Jan-06

Digger Bucket
 Godet de Défonceuse
 Cuchara retro

Ditch Cleaning
 Curage
 Vaciado

C-75006-01.1-A

1	3516000M91	6'-0"	1	Bucket Assy	Ensemble de godet	Cuchara, Conj.
2		 Ref. 1	1	Bucket	Godet	Cuchara
3	6190734M1	6'.0" 1835 mm	1	Blade	Lame	Cuchilla

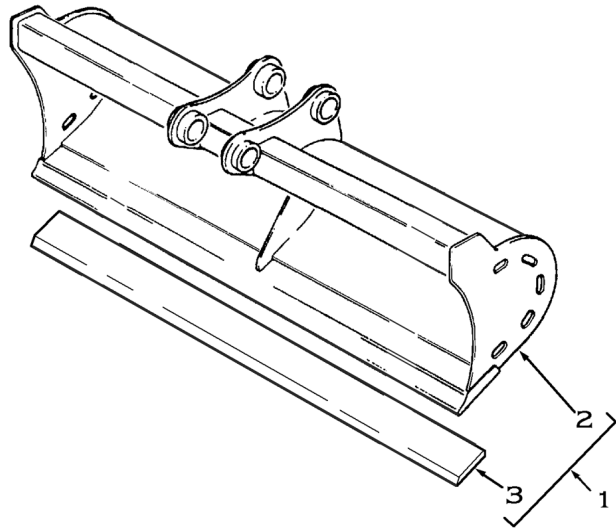

820 860 880 970 980
 TX760B TX860B
 TX870B TX970B

801 802 803 804 805 806 807 808 813 814 815 816 817 821 822 823 824 825 831
 832 833 834 841 842 843 844 845 851 852 853 854 855 921 922 923 931 932

75006C01.1

6199042M3

1

Jan-06

Digger Bucket
 Godet de Défonceuse
 Cuchara retro

Ditch Cleaning
 Curage
 Vaciado

C-75007-01.1-A

1	3516001M91	5'-0"	1	Bucket Assy	Ensemble de godet	Cuchara, Conj.
2		 Ref. 1	1	Bucket	Godet	Cuchara
3	6190735M1	5'.0" 1530 mm	1	Blade	Lame	Cuchilla

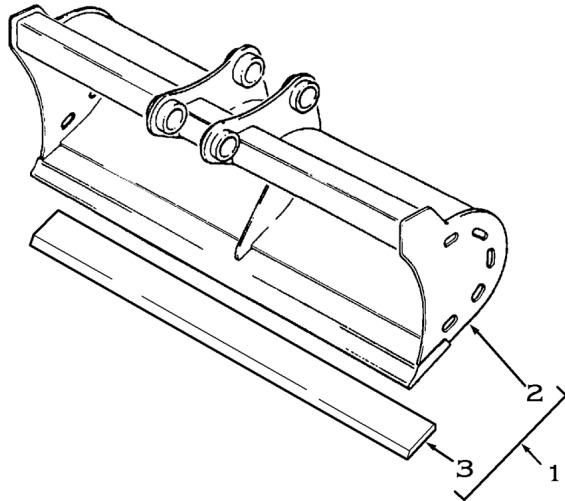

820 860 880 970 980
 TX760B TX860B
 TX870B TX970B

801 802 803 804 805 806 807 808 813 814 815 816 817 821 822 823 824 825 831
 832 833 834 841 842 843 844 845 851 852 853 854 855 921 922 923 931 932

75007C01.1

6199042M3

1

Jan-06

Digger Bucket
Godet de Défonceuse
Cuchara excavadora

Ditch Digging
Curage
Zanjas

C-98096-01.1-A

1	6102405M92		1200mm	1	Bucket Assy	Ensemble de godet	Cuchara, Conj.
2		1		1	Bucket	Godet	Cuchara
3		1		1	Blade	Lame	Cuchilla
4	6192263M1	1		2	Tooth	Dent	Diente
5	369700X1	1	3/4" UNC x 2,5"	4	Bolt	Boulon	Perno
6	375100X1	1	3/4" UNC	4	Nut	Écrou	Tuerca

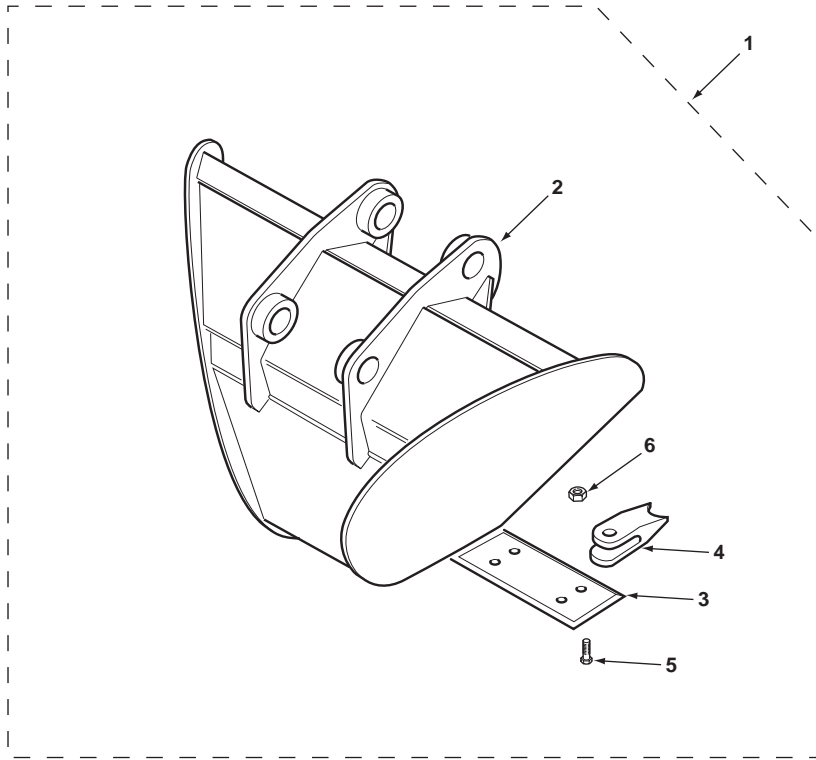

820 860 880 970 980
 TX760B TX860B
 TX870B TX970B

801 802 803 804 805 806 807 808 813 814 815 816 817 821 822 823 824 825 831
 832 833 834 841 842 843 844 845 851 852 853 854 855 921 922 923 931 932

98096C01.1

6199042M3



1

Jan-06

Digger Bucket
 Godet de Défonceuse
 Cuchara excavadora

Ditch Maintenance
 Maintenance de Curage
 Mantenimiento zanjas

C-98089-01.1-A

1	6102398M92	1500mm	1	Bucket Assy	Ensemble de godet	Cuchara, Conj.
2		1  Ref.1	1	Bucket	Godet	Cuchara
3		1  Ref.1	1	Blade	Lame	Cuchilla

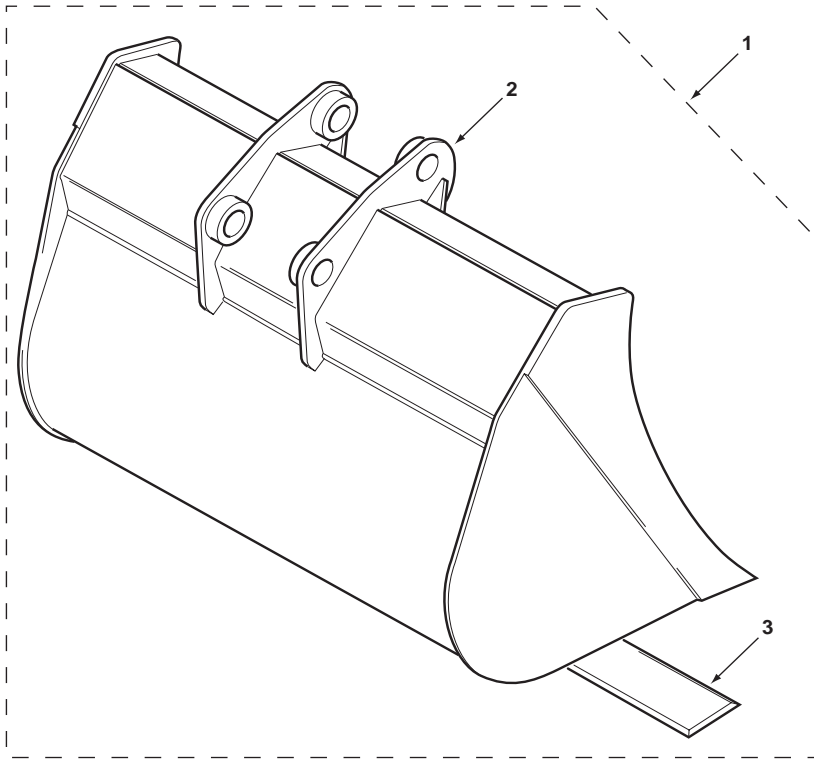



820 860 880 970 980
 TX760B TX860B
 TX870B TX970B

801 802 803 804 805 806 807 808 813 814 815 816 817 821 822 823 824 825 831
 832 833 834 841 842 843 844 845 851 852 853 854 855 921 922 923 931 932

Digger Bucket
 Godet de Défonceuse
 Cuchara excavadora

Ditch Maintenance
 Maintenance de Curage
 Mantenimiento zanjas

C-98090-01.1-A

1	6102399M92	1800mm	1	Bucket Assy	Ensemble de godet	Cuchara, Conj.
2		1  Ref.1	1	Bucket	Godet	Cuchara
3		1  Ref.1	1	Blade	Lame	Cuchilla

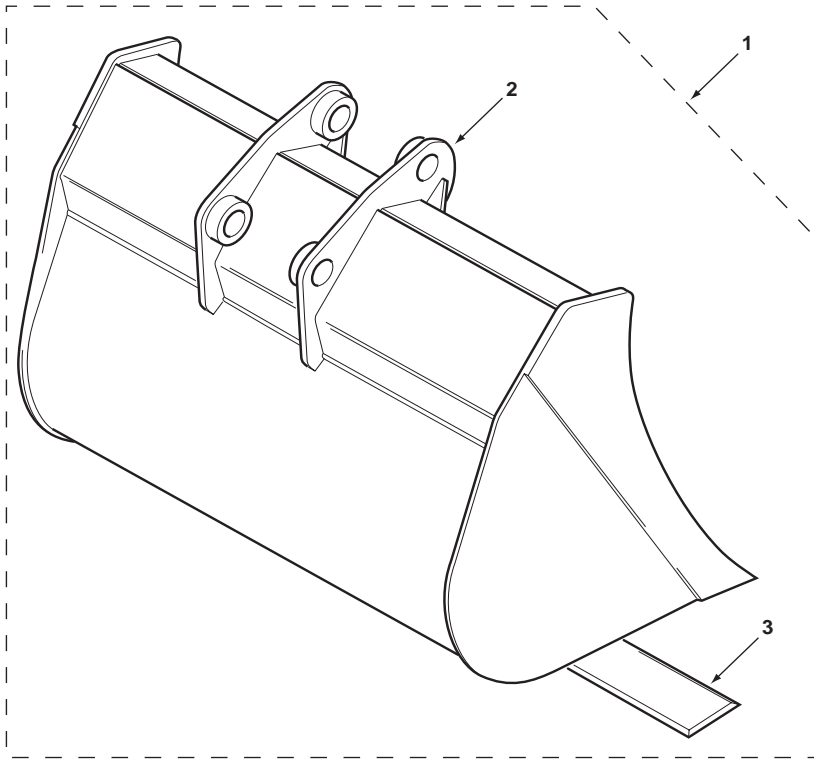

820 860 880 970 980
 TX760B TX860B
 TX870B TX970B



801 802 803 804 805 806 807 808 813 814 815 816 817 821 822 823 824 825 831
 832 833 834 841 842 843 844 845 851 852 853 854 855 921 922 923 931 932

Digger Bucket
 Godet de Défonceuse
 Cuchara excavadora

Ditch Maintenance
 Maintenance de Curage
 Mantenimiento zanjas

JCB Bucket
 Godet JCB
 Cuchara JCB

AC-98102-01.1-A

1	ACC73D		JCB Bucket	1	Accessory code	Code accessoire	Código accesorio
2	6108102M91	1	1500mm	1	Bucket Assy	Ensemble de godet	Cuchara, Conj.
3		1	 Ref. 1	1	Bucket	Godet	Cuchara
4		1	 Ref. 1	1	Blade	Lame	Cuchilla

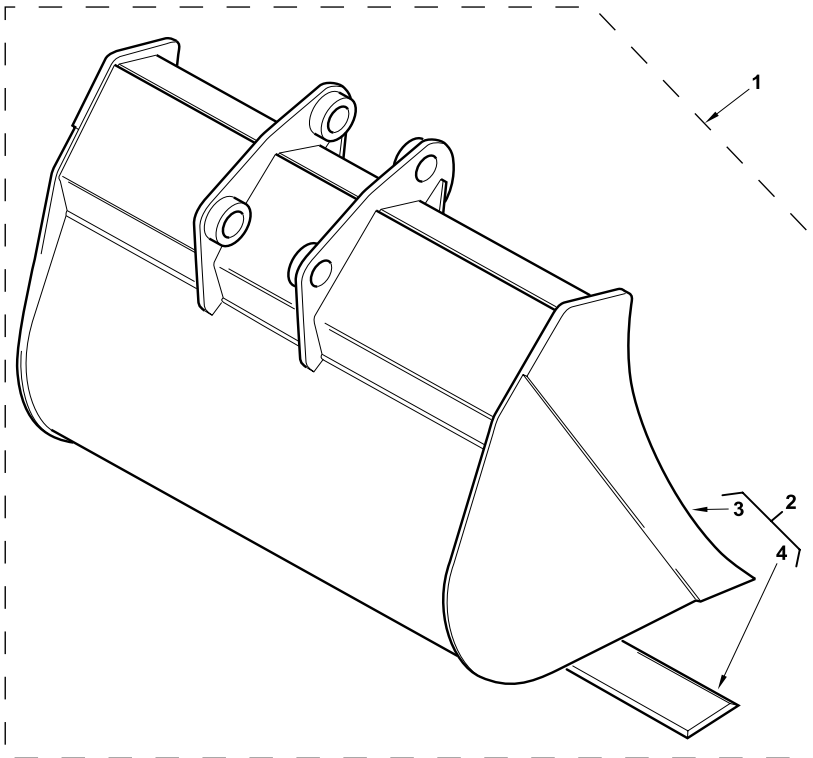

820 860 880 970 980
 TX760B TX860B
 TX870B TX970B

801 802 803 804 805 806 807 808 813 814 815 816 817 821 822 823 824 825 831
 832 833 834 841 842 843 844 845 851 852 853 854 855 921 922 923 931 932

98102AC01.1

6199042M3

1



Jan-06

Digger Bucket
 Godet de Défonceuse
 Cuchara excavadora

Ditch Maintenance
 Maintenance de Curage
 Mantenimiento zanjas

JCB Bucket
 Godet JCB
 Cuchara JCB

C-98102-01.1-A

1	6108102M91	1500mm	1	Bucket Assy	Ensemble de godet	Cuchara, Conj.
2		1  Ref. 1	1	Bucket	Godet	Cuchara
3		1  Ref. 1	1	Blade	Lame	Cuchilla

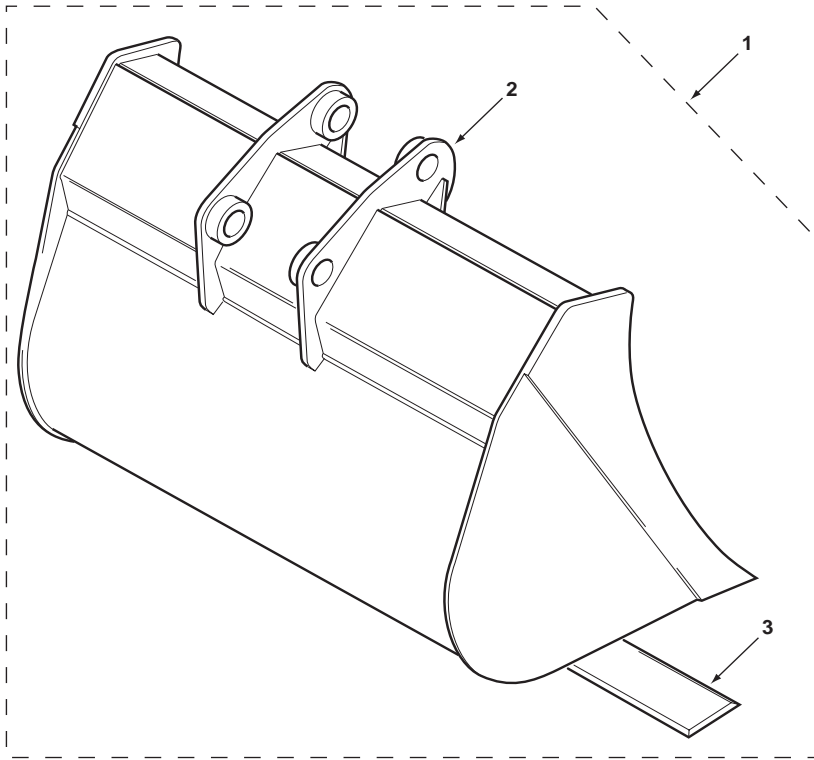

820 860 880 970 980
 TX760B TX860B
 TX870B TX970B

801 802 803 804 805 806 807 808 813 814 815 816 817 821 822 823 824 825 831
 832 833 834 841 842 843 844 845 851 852 853 854 855 921 922 923 931 932

98102C01.1

6199042M3

1



Jan-06

Digger Bucket
 Godet de Défonceuse
 Cuchara excavadora

Ditch Maintenance
 Maintenance de Curage
 Mantenimiento zanjas

JCB Bucket
 Godet JCB
 Cuchara JCB

AC-98103-01.1-A

1	ACC73G		JCB Bucket	1	Accessory code	Code accessoire	Código accesorio
2	6108103M91	1	1800mm	1	Bucket Assy	Ensemble de godet	Cuchara, Conj.
3		1	 Ref. 1	1	Bucket	Godet	Cuchara
4		1	 Ref. 1	1	Blade	Lame	Cuchilla

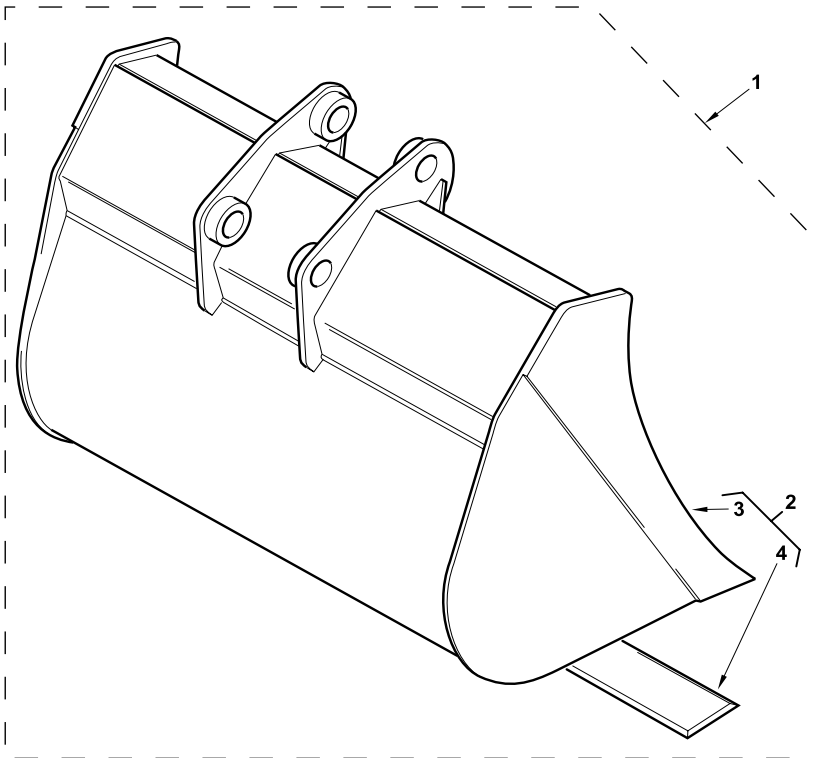

820 860 880 970 980
 TX760B TX860B
 TX870B TX970B

801 802 803 804 805 806 807 808 813 814 815 816 817 821 822 823 824 825 831
 832 833 834 841 842 843 844 845 851 852 853 854 855 921 922 923 931 932

98103AC01.1

6199042M3

1



Jan-06

Digger Bucket
 Godet de Défonceuse
 Cuchara excavadora

Ditch Maintenance
 Maintenance de Curage
 Mantenimiento zanjas

JCB Bucket
 Godet JCB
 Cuchara JCB

C-98103-01.1-A

1	6108103M91	1800mm	1	Bucket Assy	Ensemble de godet	Cuchara, Conj.
2		1  Ref. 1	1	Bucket	Godet	Cuchara
3		1  Ref. 1	1	Blade	Lame	Cuchilla

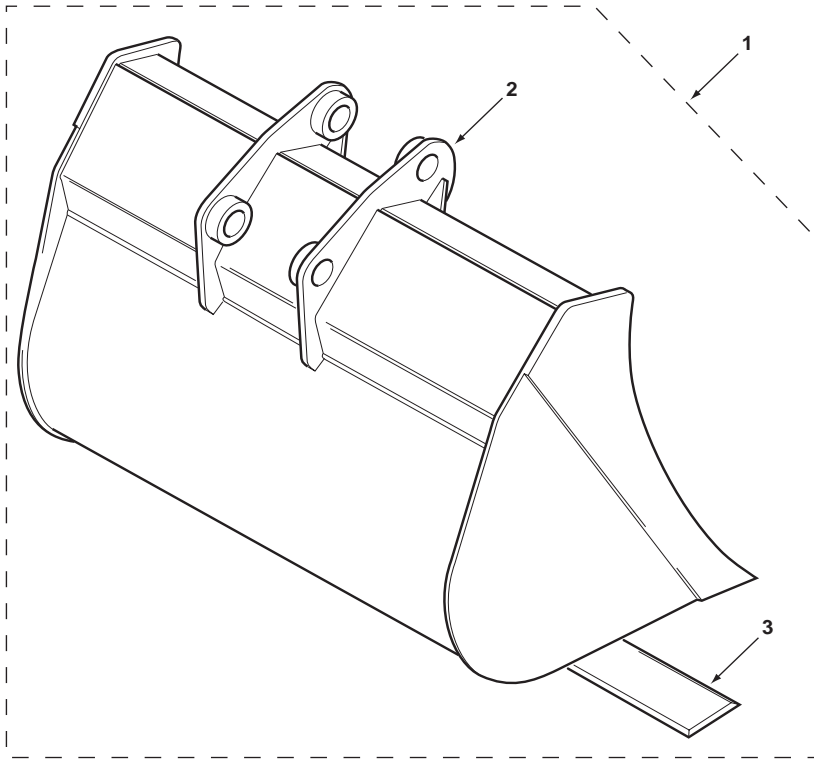

820 860 880 970 980
 TX760B TX860B
 TX870B TX970B

801 802 803 804 805 806 807 808 813 814 815 816 817 821 822 823 824 825 831
 832 833 834 841 842 843 844 845 851 852 853 854 855 921 922 923 931 932

Digger Bucket
Godet de Défonceuse
Cuchara excavadora

JCB
JCB
JCB

AC-98097-01.1-A

1	ACC73A		JCB Bucket	1	Accessory code	Code accessoire	Código accesorio
2	6108097M91	1	300mm	1	Bucket Assy	Ensemble de godet	Cuchara, Conj.

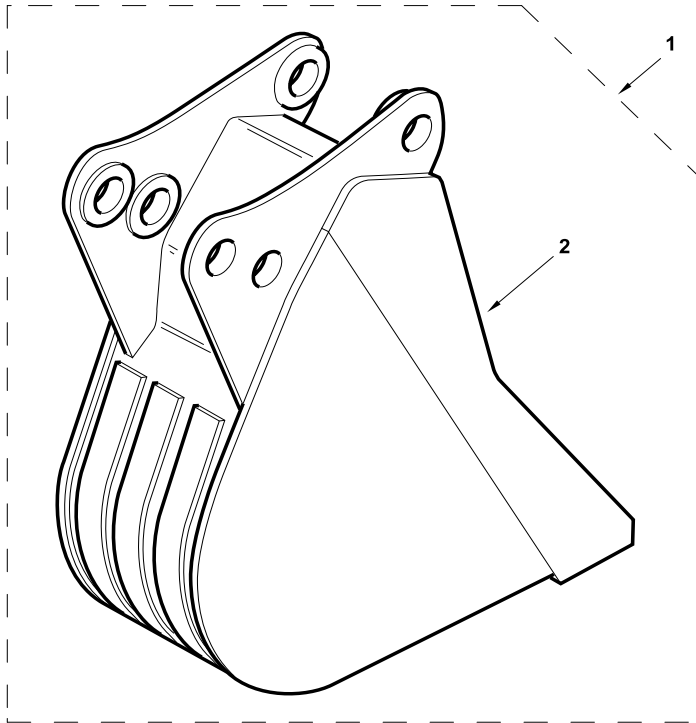

820 860 880 970 980
TX760B TX860B
TX870B TX970B

801 802 803 804 805 806 807 808 813 814 815 816 817 821 822 823 824 825 831
832 833 834 841 842 843 844 845 851 852 853 854 855 921 922 923 931 932

98097AC01.1

6199042M3

1

Jan-06

Digger Bucket
Godet de Défonceuse
Cuchara excavadora

JCB
JCB
JCB

C-98097-01.1-A

1	6108097M91	300mm	1	Bucket Assy	Ensemble de godet	Cuchara, Conj.
---	------------	-------	---	-------------	-------------------	----------------

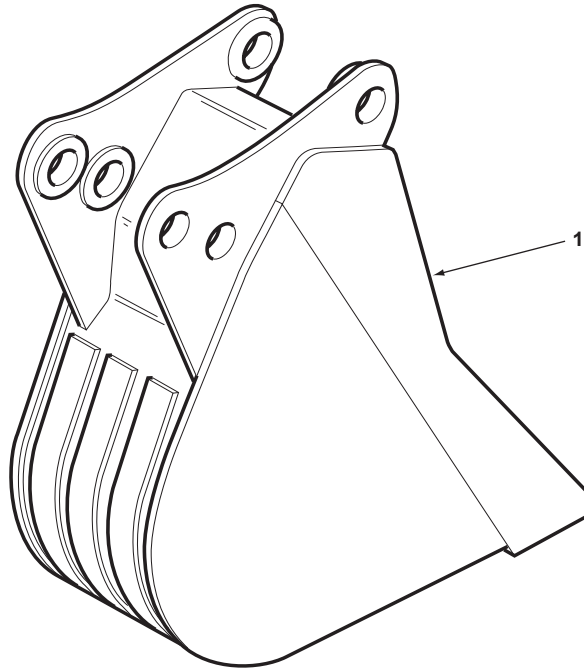

820 860 880 970 980
TX760B TX860B
TX870B TX970B

801 802 803 804 805 806 807 808 813 814 815 816 817 821 822 823 824 825 831
832 833 834 841 842 843 844 845 851 852 853 854 855 921 922 923 931 932

98097C01.1

6199042M3

1

Jan-06

Digger Bucket
 Godet de Défonceuse
 Cuchara excavadora

JCB
 JCB
 JCB

AC-98098-01.1-A

1	ACC73B		JCB Bucket	1	Accessory code	Code accessoire	Código accesorio
2	6108098M91	1	450mm	1	Bucket Assy	Ensemble de godet	Cuchara, Conj.

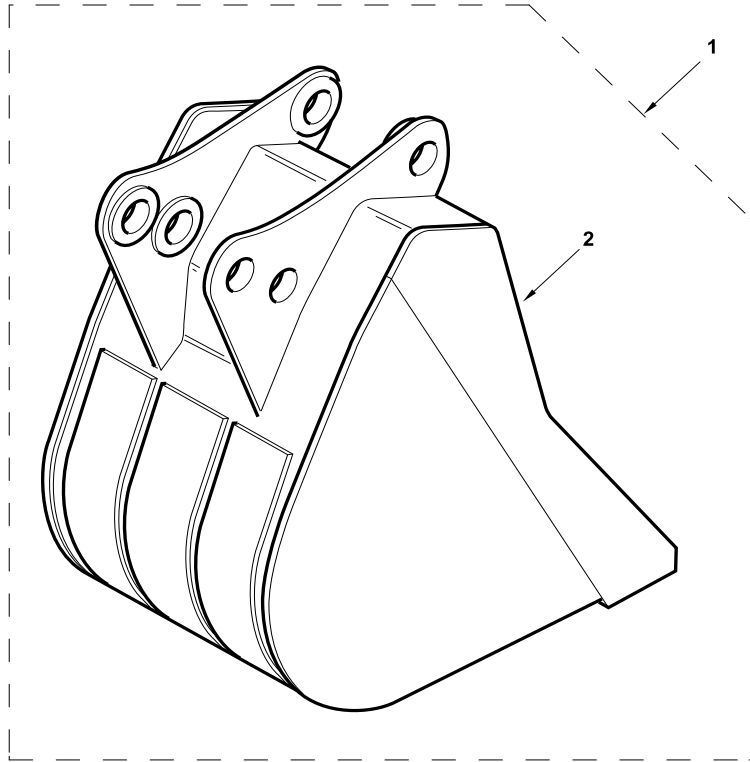

820 860 880 970 980
 TX760B TX860B
 TX870B TX970B

801 802 803 804 805 806 807 808 813 814 815 816 817 821 822 823 824 825 831
 832 833 834 841 842 843 844 845 851 852 853 854 855 921 922 923 931 932

Digger Bucket
Godet de Défonceuse
Cuchara excavadora

JCB
JCB
JCB

C-98098-01.1-A

1	6108098M91	450mm	1	Bucket Assy	Ensemble de godet	Cuchara, Conj.
---	------------	-------	---	-------------	-------------------	----------------

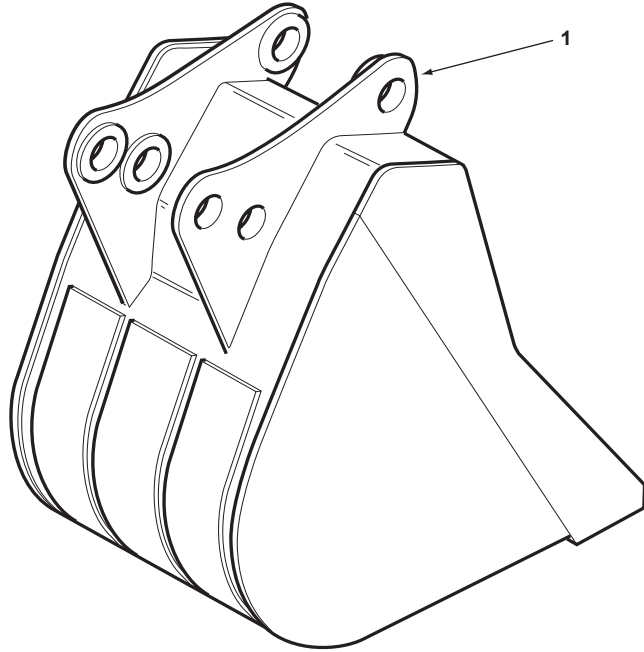

820 860 880 970 980
TX760B TX860B
TX870B TX970B

801 802 803 804 805 806 807 808 813 814 815 816 817 821 822 823 824 825 831
832 833 834 841 842 843 844 845 851 852 853 854 855 921 922 923 931 932

98098C01.1

6199042M3

1

Jan-06

Digger Bucket
 Godet de Défonceuse
 Cuchara excavadora

JCB
 JCB
 JCB

AC-98099-01.1-A

1	ACC73C		JCB Bucket	1	Accessory code	Code accessoire	Código accesorio
2	6108099M91	1	600mm	1	Bucket Assy	Ensemble de godet	Cuchara, Conj.

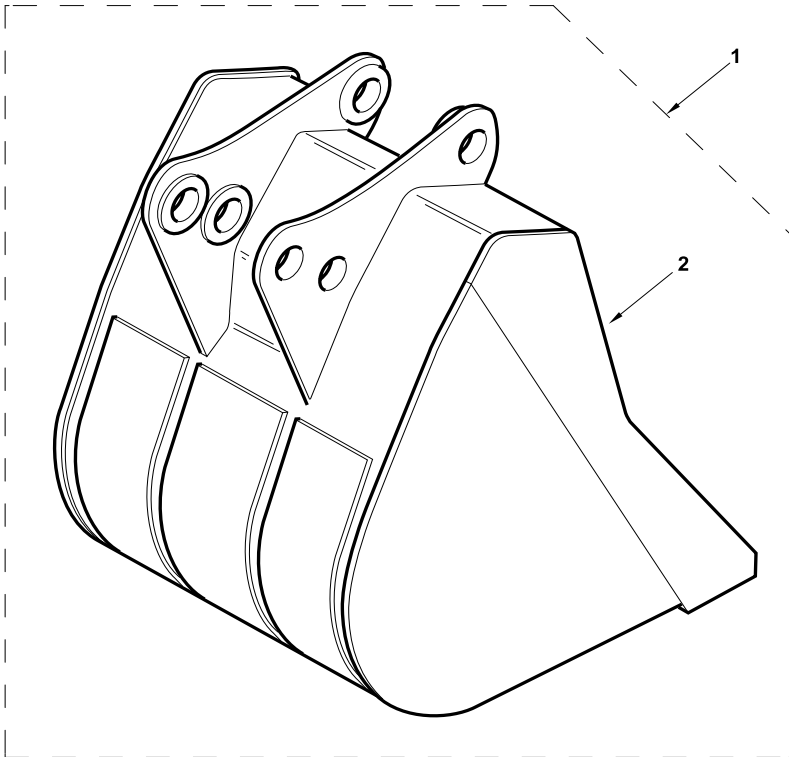

820 860 880 970 980
 TX760B TX860B
 TX870B TX970B

801 802 803 804 805 806 807 808 813 814 815 816 817 821 822 823 824 825 831
 832 833 834 841 842 843 844 845 851 852 853 854 855 921 922 923 931 932

Digger Bucket
Godet de Défonceuse
Cuchara excavadora

JCB
JCB
JCB

C-98099-01.1-A

1	6108099M91	600mm	1	Bucket Assy	Ensemble de godet	Cuchara, Conj.
---	------------	-------	---	-------------	-------------------	----------------

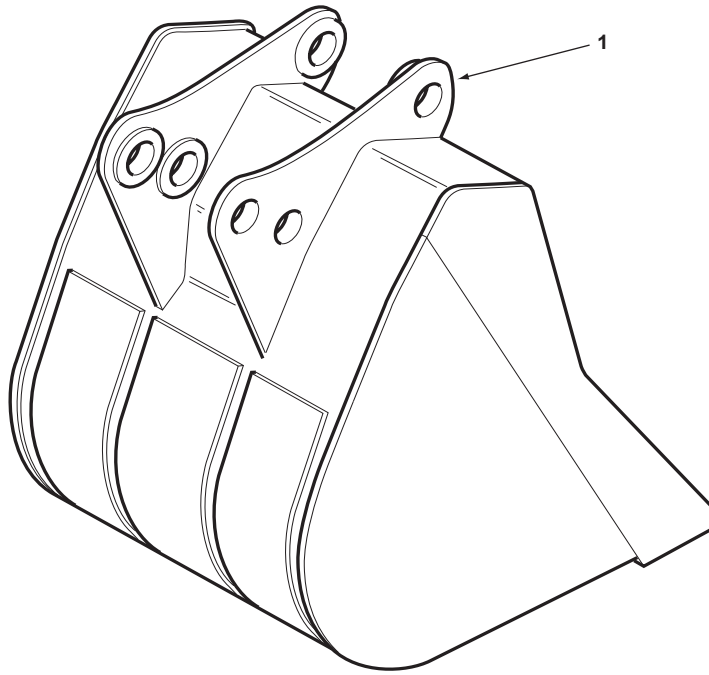

820 860 880 970 980
TX760B TX860B
TX870B TX970B

801 802 803 804 805 806 807 808 813 814 815 816 817 821 822 823 824 825 831
832 833 834 841 842 843 844 845 851 852 853 854 855 921 922 923 931 932

98099C01.1

6199042M3

1

Jan-06

Digger Bucket
 Godet de Défonceuse
 Cuchara excavadora

JCB
 JCB
 JCB

AC-98100-01.1-A

1	ACC73D		JCB Bucket	1	Accessory code	Code accessoire	Código accesorio
2	6108100M91	1	750mm	1	Bucket Assy	Ensemble de godet	Cuchara, Conj.

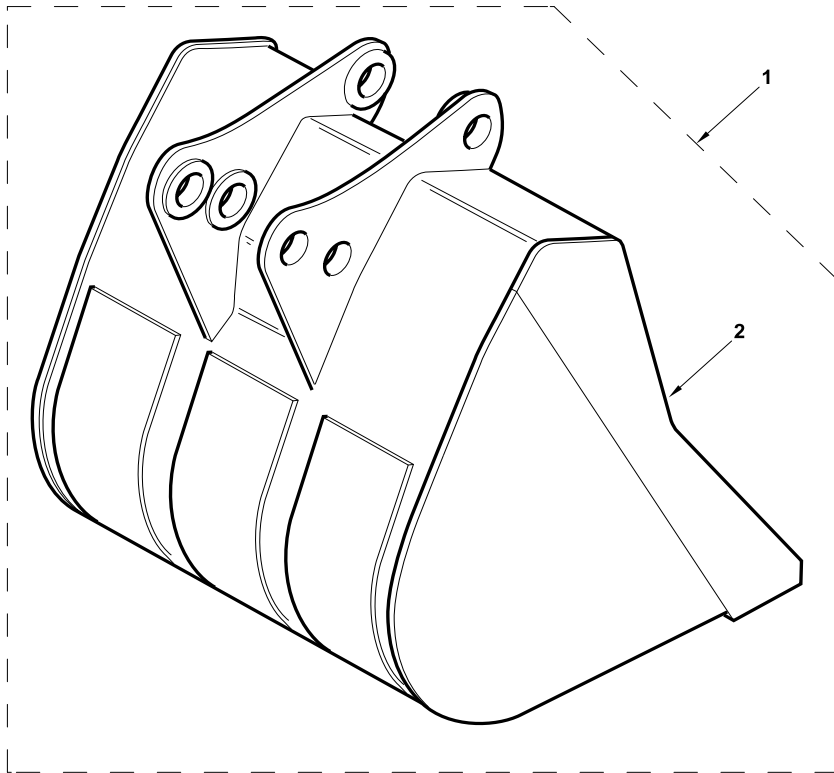

820 860 880 970 980
 TX760B TX860B
 TX870B TX970B

801 802 803 804 805 806 807 808 813 814 815 816 817 821 822 823 824 825 831
 832 833 834 841 842 843 844 845 851 852 853 854 855 921 922 923 931 932

98100AC01.1

6199042M3

1

Jan-06

Digger Bucket
Godet de Défonceuse
Cuchara excavadora

JCB
JCB
JCB

C-98100-01.1-A

1	6108100M91	750mm	1	Bucket Assy	Ensemble de godet	Cuchara, Conj.
---	------------	-------	---	-------------	-------------------	----------------

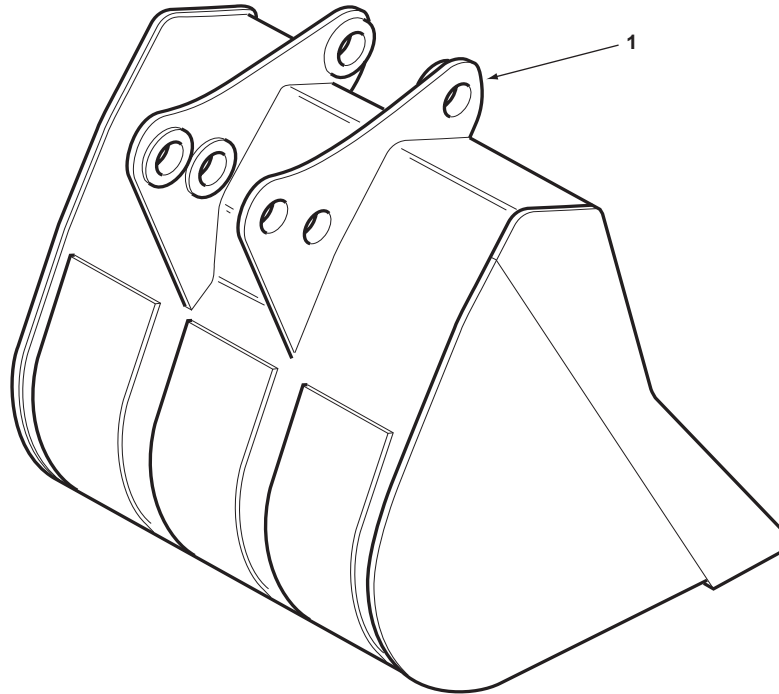

820 860 880 970 980
TX760B TX860B
TX870B TX970B

801 802 803 804 805 806 807 808 813 814 815 816 817 821 822 823 824 825 831
832 833 834 841 842 843 844 845 851 852 853 854 855 921 922 923 931 932

98100C01.1

6199042M3

1

Jan-06

Digger Bucket
 Godet de Défonceuse
 Cuchara excavadora

JCB
 JCB
 JCB

AC-98101-01.1-A

1	ACC73E		JCB Bucket	1	Accessory code	Code accessoire	Código accesorio
2	6108101M91	1	900mm	1	Bucket Assy	Ensemble de godet	Cuchara, Conj.

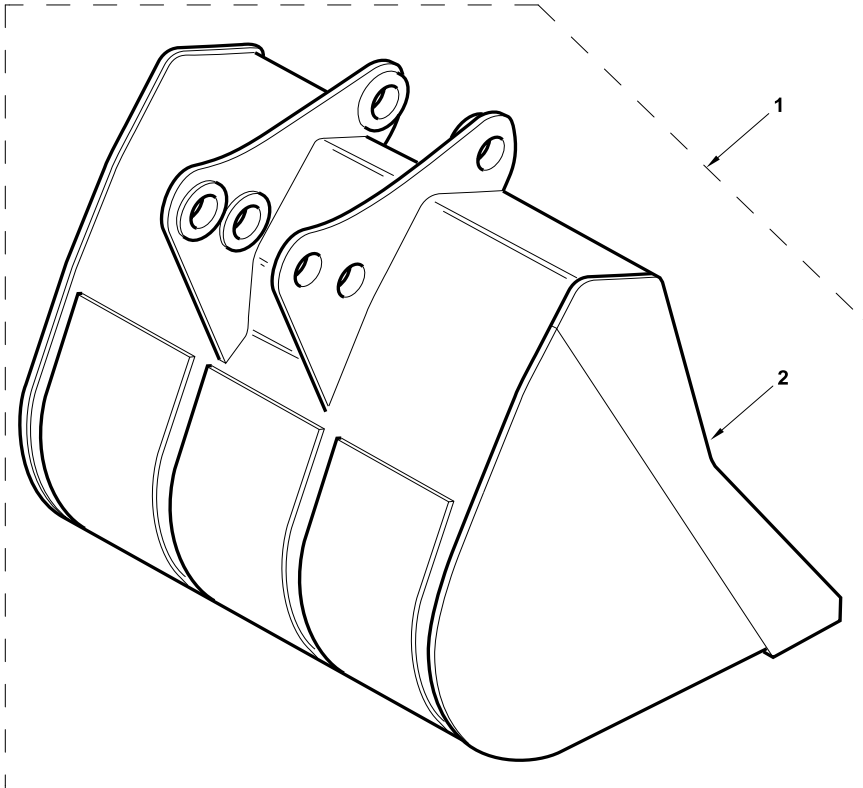

820 860 880 970 980
 TX760B TX860B
 TX870B TX970B

801 802 803 804 805 806 807 808 813 814 815 816 817 821 822 823 824 825 831
 832 833 834 841 842 843 844 845 851 852 853 854 855 921 922 923 931 932

98101AC01.1

6199042M3

1

Jan-06

Digger Bucket
Godet de Défonceuse
Cuchara excavadora

JCB
JCB
JCB

C-98101-01.1-A

1	6108101M91	900mm	1	Bucket Assy	Ensemble de godet	Cuchara, Conj.
---	------------	-------	---	-------------	-------------------	----------------

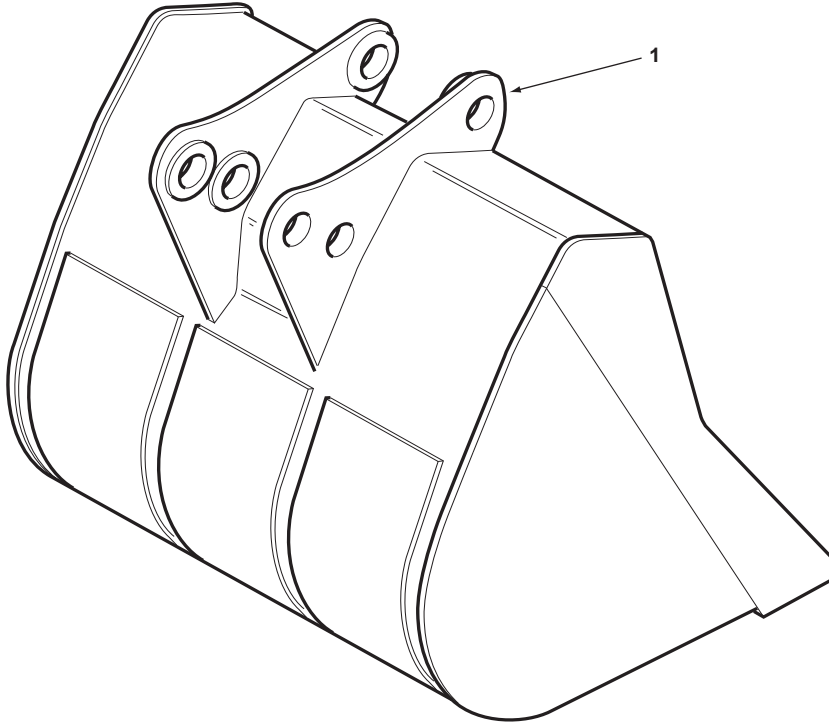

820 860 880 970 980
TX760B TX860B
TX870B TX970B

801 802 803 804 805 806 807 808 813 814 815 816 817 821 822 823 824 825 831
832 833 834 841 842 843 844 845 851 852 853 854 855 921 922 923 931 932

98101C01.1

6199042M3

1

Jan-06

Digger Bucket
 Godet de Défonceuse
 Cuchara retro

Medium Profile
 Profil Moyen
 Perfil medio

C-75008-01.1-A

1	6106350M91	(A) 24"	1	Bucket Assy	Ensemble de godet	Cuchara, Conj.
2		1	1	Bucket	Godet	Cuchara
3	3501770M2	1	6	Bushing	Bague	Anillo
4	3509557M2	1	1	Blade	Lame	Cuchilla
5	6106318M1	1	5	Adaptor, Tooth	Support de dent	Soporte de diente
6	6106319M1	1	5	Tooth	Dent	Diente
7	6106320M1	1	5	Pin	Axe	Pasador

A With weld on teeth
 Avec dents soudées
 Con dientes soldados

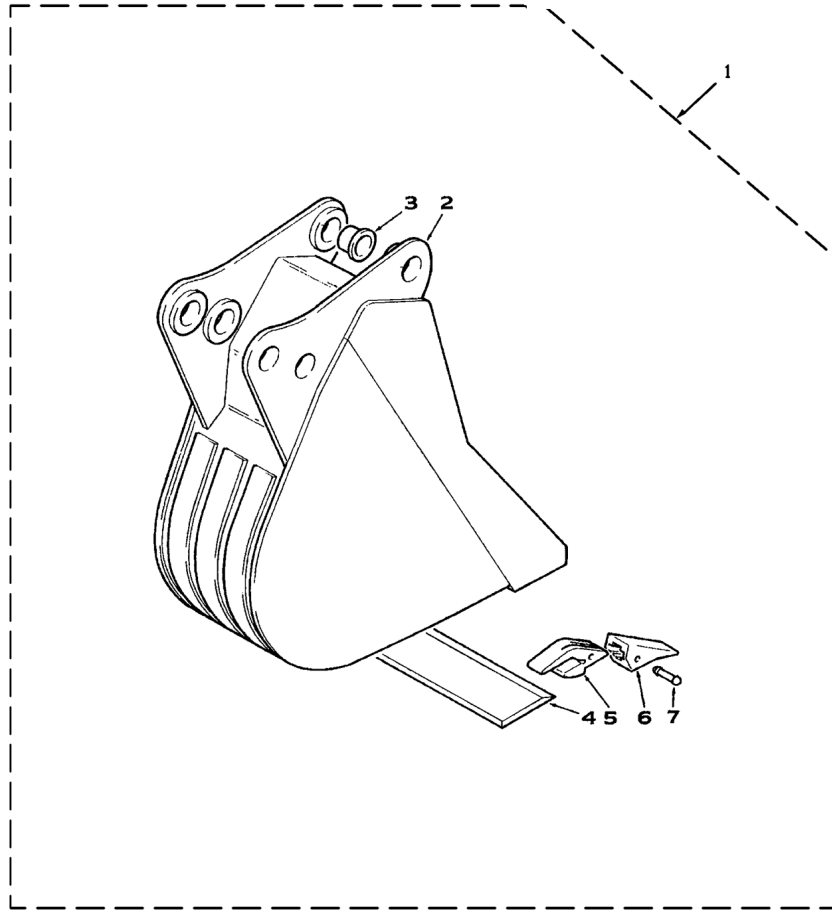

820 860 880 970 980
 TX760B TX860B
 TX870B TX970B

801 802 803 804 805 806 807 808 813 814 815 816 817 821 822 823 824 825 831
 832 833 834 841 842 843 844 845 851 852 853 854 855 921 922 923 931 932

Digger Bucket
Godet de Défonceuse
Cuchara excavadora

Premium
Superior

C-98084-01.1-A

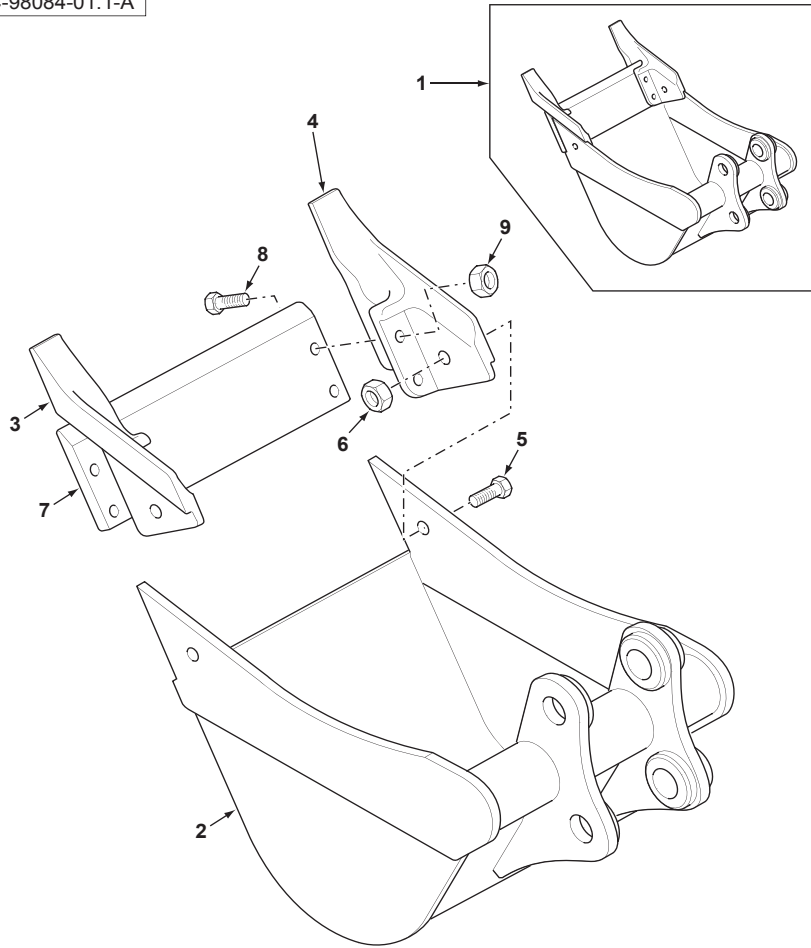

1	6102393M92	300mm	1	Bucket Assy	Ensemble de godet	Cuchara, Conj.
2		1	▶ Ref. 1	Bucket	Godet	Cuchara
3	6192264M1	1	◀	Edge, Cutting	Lame d'attaque	Cuchilla de ataque
4	6192265M1	1	▶	Edge, Cutting	Lame d'attaque	Cuchilla de ataque
5	354710X1	1	3/4" UNC x 2"	Bolt	Boulon	Perno
6	375100X1	1	3/4" UNC	Nut	Écrou	Tuerca
7		1	▶ Ref. 1	Blade	Lame	Cuchilla
8	369700X1	1	3/4" UNC x 2,5"	Bolt	Boulon	Perno
9	375100X1	1	3/4" UNC	Nut	Écrou	Tuerca



820 860 880 970 980
 TX760B TX860B
 TX870B TX970B

801 802 803 804 805 806 807 808 813 814 815 816 817 821 822 823 824 825 831
 832 833 834 841 842 843 844 845 851 852 853 854 855 921 922 923 931 932

98084C01.1

6199042M3

1

Jan-06

Digger Bucket
Godet de Défonceuse
Cuchara excavadora

Premium
Superior

C-98085-01.1-A

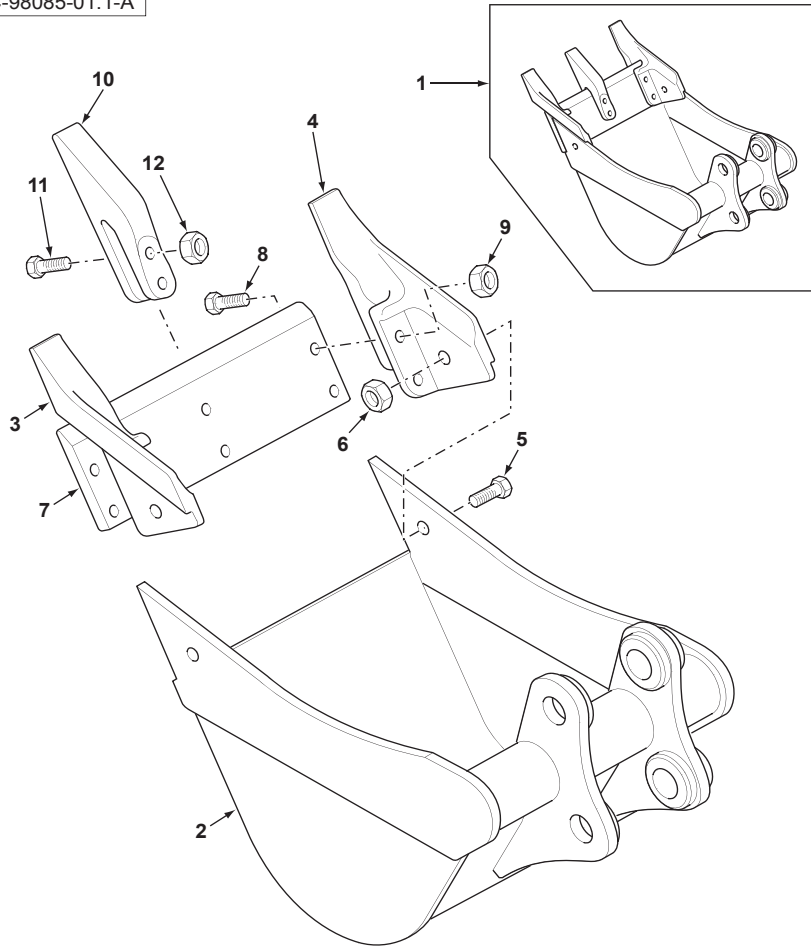

1	6102394M92	450mm	1	Bucket Assy	Ensemble de godet	Cuchara, Conj.
2		1	▶ Ref. 1	Bucket	Godet	Cuchara
3	6192264M1	1	◀	Edge, Cutting	Lame d'attaque	Cuchilla de ataque
4	6192265M1	1	▶	Edge, Cutting	Lame d'attaque	Cuchilla de ataque
5	354710X1	1	3/4" UNC x 2"	Bolt	Boulon	Perno
6	375100X1	1	3/4" UNC	Nut	Écrou	Tuerca
7		1	▶ Ref. 1	Blade	Lame	Cuchilla
8	369700X1	1	3/4" UNC x 2,5"	Bolt	Boulon	Perno
9	375100X1	1	3/4" UNC	Nut	Écrou	Tuerca
10	6192263M1	1		Tooth	Dent	Diente
11	369700X1	1	3/4" UNC x 2,5"	Bolt	Boulon	Perno
12	375100X1	1	3/4" UNC	Nut	Écrou	Tuerca



820 860 880 970 980
 TX760B TX860B
 TX870B TX970B

801 802 803 804 805 806 807 808 813 814 815 816 817 821 822 823 824 825 831
 832 833 834 841 842 843 844 845 851 852 853 854 855 921 922 923 931 932

98085C01.1

6199042M3

1

Jan-06

Digger Bucket
Godet de Défonceuse
Cuchara excavadora

Premium
Superior

C-98086-01.1-A

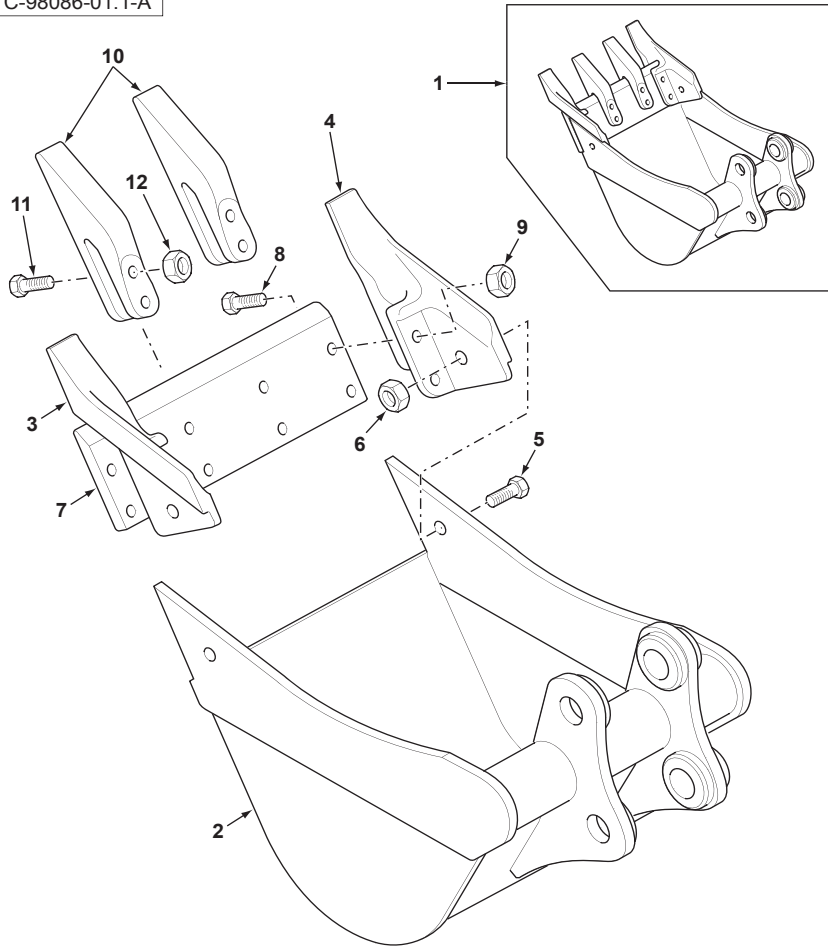

1	6102395M92	600mm	1	Bucket Assy	Ensemble de godet	Cuchara, Conj.
2		1	▶ Ref. 1	Bucket	Godet	Cuchara
3	6192264M1	1	◀	Edge, Cutting	Lame d'attaque	Cuchilla de ataque
4	6192265M1	1	▶	Edge, Cutting	Lame d'attaque	Cuchilla de ataque
5	354710X1	1	3/4" UNC x 2"	Bolt	Boulon	Perno
6	375100X1	1	3/4" UNC	Nut	Écrou	Tuerca
7		1	▶ Ref. 1	Blade	Lame	Cuchilla
8	369700X1	1	3/4" UNC x 2,5"	Bolt	Boulon	Perno
9	375100X1	1	3/4" UNC	Nut	Écrou	Tuerca
10	6192263M1	1		Tooth	Dent	Diente
11	369700X1	1	3/4" UNC x 2,5"	Bolt	Boulon	Perno
12	375100X1	1	3/4" UNC	Nut	Écrou	Tuerca



820 860 880 970 980
 TX760B TX860B
 TX870B TX970B

801 802 803 804 805 806 807 808 813 814 815 816 817 821 822 823 824 825 831
 832 833 834 841 842 843 844 845 851 852 853 854 855 921 922 923 931 932

98086C01.1

6199042M3

1

Jan-06

Digger Bucket
Godet de Défonceuse
Cuchara excavadora

Premium
Superior

C-98087-01.1-A

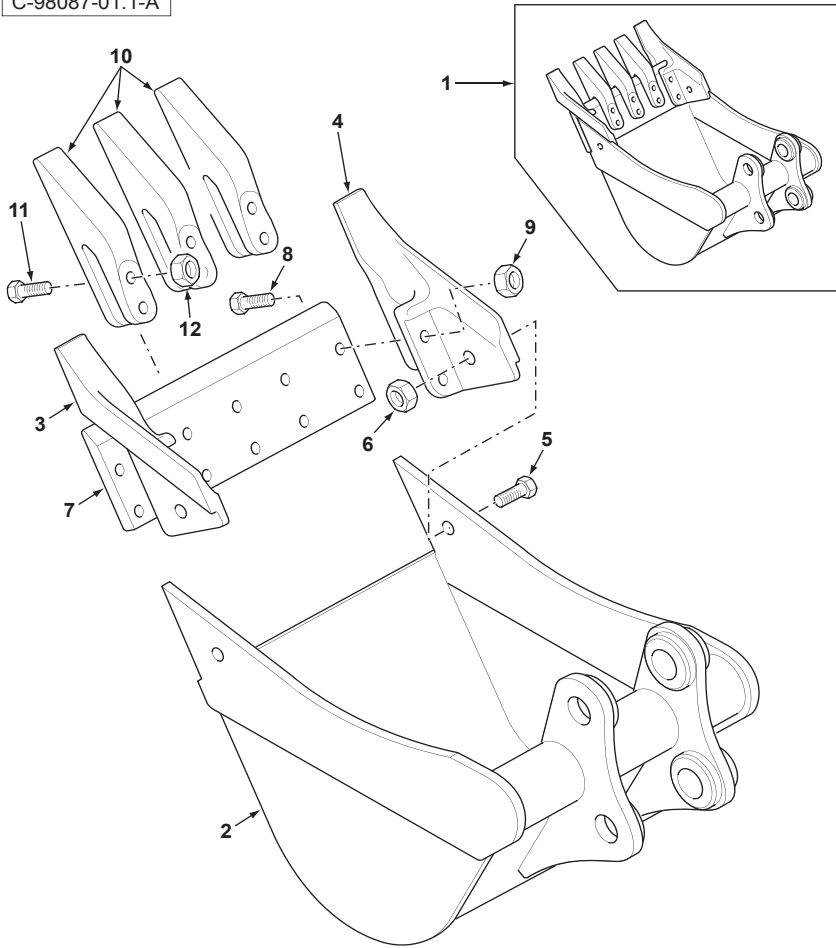

1	6102396M92	750mm	1	Bucket Assy	Ensemble de godet	Cuchara, Conj.
2			1	Bucket	Godet	Cuchara
3	6192264M1	▶ Ref. 1	1	Edge, Cutting	Lame d'attaque	Cuchilla de ataque
4	6192265M1	◀ Ref. 1	1	Edge, Cutting	Lame d'attaque	Cuchilla de ataque
5	354710X1	3/4" UNC x 2"	4	Bolt	Boulon	Perno
6	375100X1	3/4" UNC	4	Nut	Écrou	Tuerca
7		▶ Ref. 1	1	Blade	Lame	Cuchilla
8	369700X1	3/4" UNC x 2,5"	4	Bolt	Boulon	Perno
9	375100X1	3/4" UNC	4	Nut	Écrou	Tuerca
10	6192263M1		3	Tooth	Dent	Diente
11	369700X1	3/4" UNC x 2,5"	6	Bolt	Boulon	Perno
12	375100X1	3/4" UNC	6	Nut	Écrou	Tuerca



820 860 880 970 980
 TX760B TX860B
 TX870B TX970B

801 802 803 804 805 806 807 808 813 814 815 816 817 821 822 823 824 825 831
 832 833 834 841 842 843 844 845 851 852 853 854 855 921 922 923 931 932

98087C01.1

6199042M3

1

Jan-06

Digger Bucket
Godet de Défonceuse
Cuchara excavadora

Premium
Superior

C-98088-01.1-A

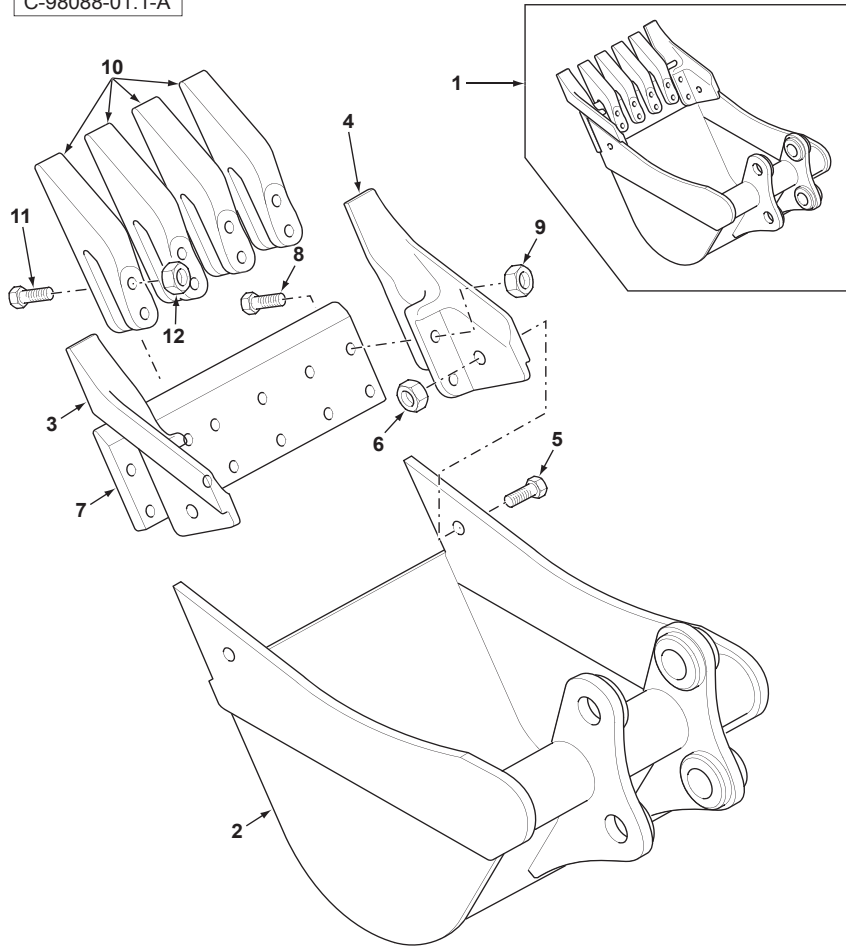

1	6102397M92	900mm	1	Bucket Assy	Ensemble de godet	Cuchara, Conj.
2			1	Bucket	Godet	Cuchara
3	6192264M1	▶ Ref. 1	1	Edge, Cutting	Lame d'attaque	Cuchilla de ataque
4	6192265M1	◀ Ref. 1	1	Edge, Cutting	Lame d'attaque	Cuchilla de ataque
5	354710X1	3/4" UNC x 2"	4	Bolt	Boulon	Perno
6	375100X1	3/4" UNC	4	Nut	Écrou	Tuerca
7		▶ Ref. 1	1	Blade	Lame	Cuchilla
8	369700X1	3/4" UNC x 2,5"	4	Bolt	Boulon	Perno
9	375100X1	3/4" UNC	4	Nut	Écrou	Tuerca
10	6192263M1		4	Tooth	Dent	Diente
11	369700X1	3/4" UNC x 2,5"	8	Bolt	Boulon	Perno
12	375100X1	3/4" UNC	8	Nut	Écrou	Tuerca



820 860 880 970 980
 TX760B TX860B
 TX870B TX970B

801 802 803 804 805 806 807 808 813 814 815 816 817 821 822 823 824 825 831
 832 833 834 841 842 843 844 845 851 852 853 854 855 921 922 923 931 932

98088C01.1

6199042M3

1

Jan-06

Digger Bucket
Godet de Défonceuse
Cuchara retro

Standard
Standard
Estándar

C-75001-01.1-A

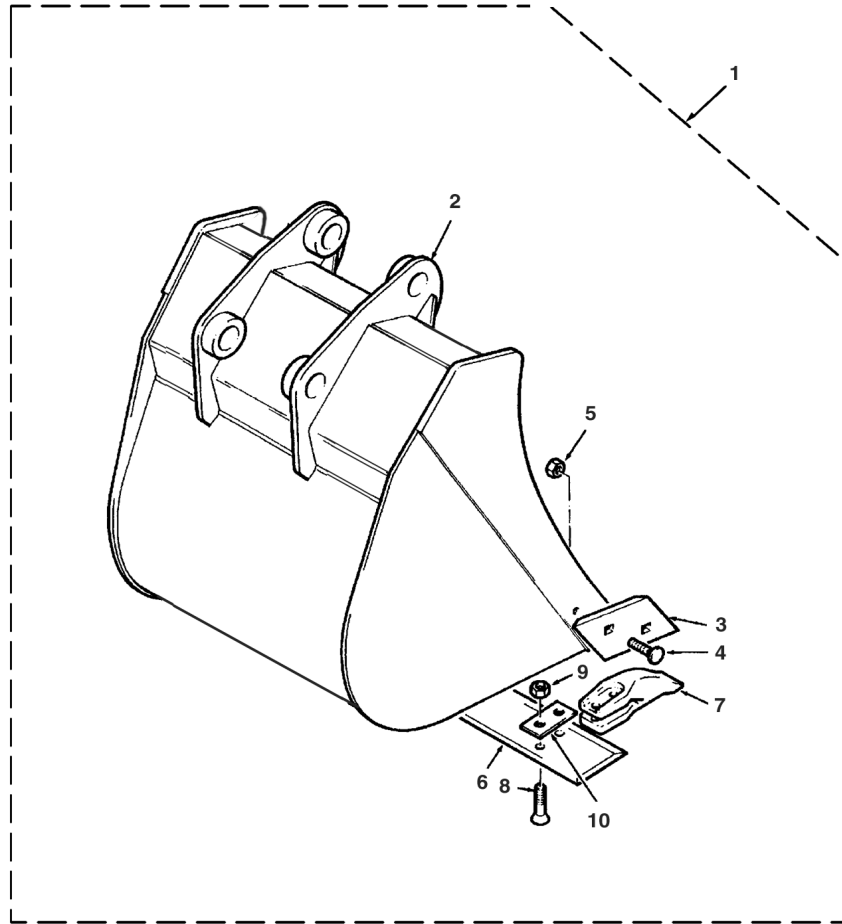

1	3516453M93	600 mm	1	Bucket Assy	Ensemble de godet	Cuchara, Conj.
2		1 Ref.1	1	Bucket	Godet	Cuchara
3	3500531M1	1	1	Edge, Cutting	Lame d'attaque	Cuchilla de ataque
3	3500532M1	1	1	Edge, Cutting	Lame d'attaque	Cuchilla de ataque
4	353422X1	1 5/8" UNF x 2.0"	4	Bolt	Boulon	Perno
5	353427X1	1 5/8" UNF	4	Nut	Écrou	Tuerca
6	3516479M2	1 600 mm	1	Blade	Lame	Cuchilla
7	1462201M3	1	X	Tooth	Dent	Diente
8	353915X1	1 5/8" UNF x 2.62"	X	Bolt	Boulon	Perno
9	353427X1	1 5/8" UNF	X	Nut	Écrou	Tuerca
10	862738M1	1 0,8 mm	X	Shim	Cale	Calce
10	862739M1	1 1,6 mm	X	Shim	Cale	Calce



820 860 880 970 980
 TX760B TX860B
 TX870B TX970B

801 802 803 804 805 806 807 808 813 814 815 816 817 821 822 823 824 825 831
 832 833 834 841 842 843 844 845 851 852 853 854 855 921 922 923 931 932

75001C01.1

6199042M3

1

Jan-06

Digger Bucket
Godet de Défonceuse
Cuchara retro

Standard
Standard
Estándar

C-75002-01.1-A

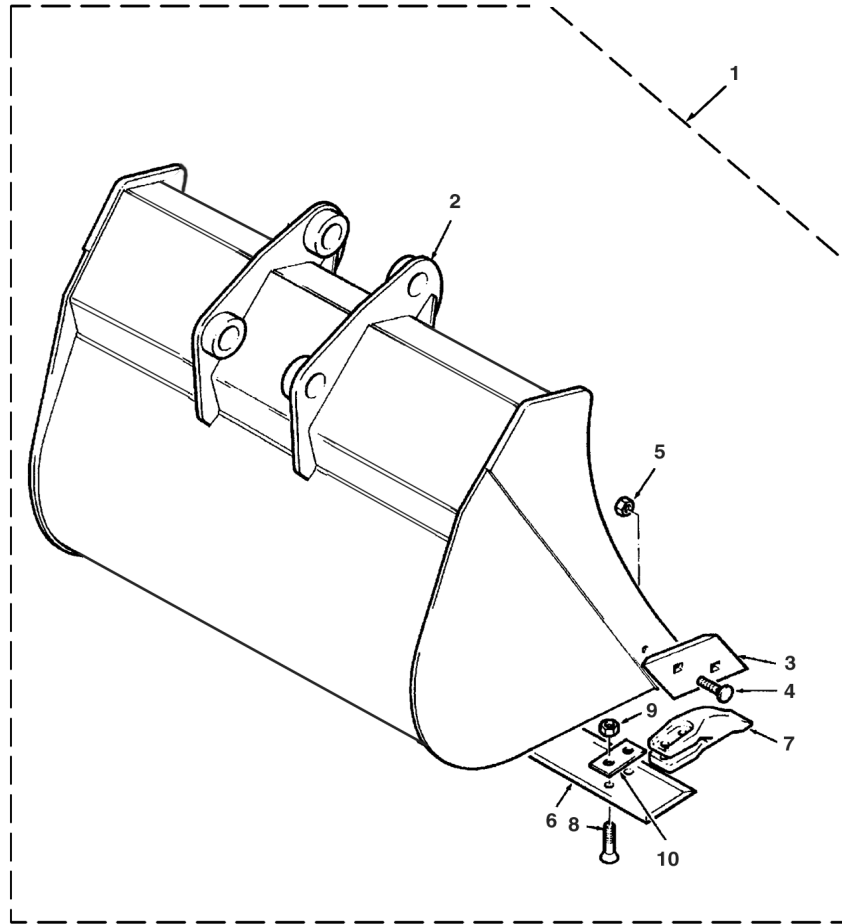

1	3516457M93	900 mm	1	Bucket Assy	Ensemble de godet	Cuchara, Conj.
2		1	▶ Ref.1	Bucket	Godet	Cuchara
3	3500531M1	1	◀	Edge, Cutting	Lame d'attaque	Cuchilla de ataque
3	3500532M1	1	▶	Edge, Cutting	Lame d'attaque	Cuchilla de ataque
4	353422X1	1	5/8" UNF x 2.0"	Bolt	Boulon	Perno
5	353427X1	1	5/8" UNF	Nut	Écrou	Tuerca
6	3516477M2	1	900 mm	Blade	Lame	Cuchilla
7	1462201M3	1		X Tooth	Dent	Diente
8	353915X1	1	5/8" UNF x 2.62"	X Bolt	Boulon	Perno
9	353427X1	1	5/8" UNF	X Nut	Écrou	Tuerca
10	862738M1	1	0,8 mm	X Shim	Cale	Calce
10	862739M1	1	1,6 mm	X Shim	Cale	Calce



820 860 880 970 980
 TX760B TX860B
 TX870B TX970B

801 802 803 804 805 806 807 808 813 814 815 816 817 821 822 823 824 825 831
 832 833 834 841 842 843 844 845 851 852 853 854 855 921 922 923 931 932

75002C01.1

6199042M3

1

Jan-06

Digger Bucket
 Godet de Défonceuse
 Cuchara retro

Standard
 Standard
 Estándar

C-75003-01.1-A

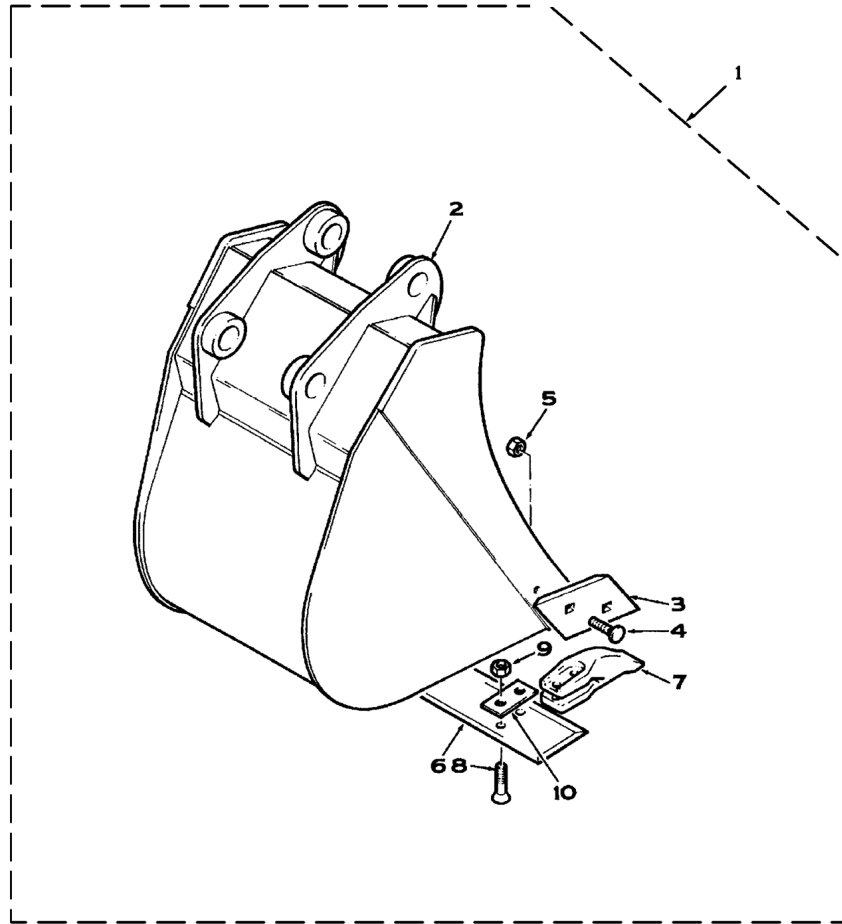

1	3516451M93	450 mm	1	Bucket Assy	Ensemble de godet	Cuchara, Conj.
2		1 Ref.1	1	Bucket	Godet	Cuchara
3	3500531M1	1	1	Edge, Cutting	Lame d'attaque	Cuchilla de ataque
3	3500532M1	1	1	Edge, Cutting	Lame d'attaque	Cuchilla de ataque
4	353422X1	1 5/8" UNF x 2.0"	4	Bolt	Boulon	Perno
5	353427X1	1 5/8" UNF	4	Nut	Écrou	Tuerca
6	3516480M2	1 450 mm	1	Blade	Lame	Cuchilla
7	1462201M3	1	X	Tooth	Dent	Diente
8	353915X1	1 5/8" UNF x 2.62"	X	Bolt	Boulon	Perno
9	353427X1	1 5/8" UNF	X	Nut	Écrou	Tuerca
10	862738M1	1 0,8 mm	X	Shim	Cale	Calce
10	862739M1	1 1,6 mm	X	Shim	Cale	Calce



820 860 880 970 980
 TX760B TX860B
 TX870B TX970B

801 802 803 804 805 806 807 808 813 814 815 816 817 821 822 823 824 825 831
 832 833 834 841 842 843 844 845 851 852 853 854 855 921 922 923 931 932

75003C01.1

6199042M3

1



Jan-06

Digger Bucket
Godet de Défonceuse
Cuchara retro

Standard
Standard
Estándar

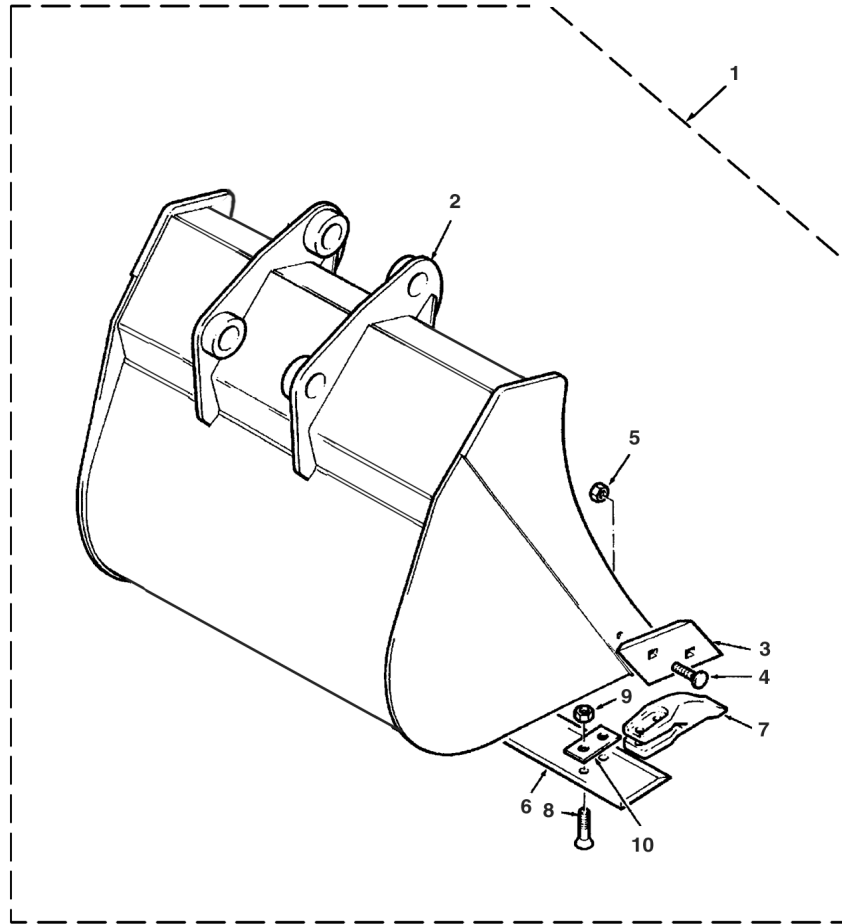
C-75004-01.1-A



1	3516455M93	750 mm	1	Bucket Assy	Ensemble de godet	Cuchara, Conj.
2		1  Ref.1	1	Bucket	Godet	Cuchara
3	3500531M1	1 	1	Edge, Cutting	Lame d'attaque	Cuchilla de ataque
3	3500532M1	1 	1	Edge, Cutting	Lame d'attaque	Cuchilla de ataque
4	353422X1	1 5/8" UNF x 2.0"	4	Bolt	Boulon	Perno
5	353427X1	1 5/8" UNF	4	Nut	Écrou	Tuerca
6	3516478M2	1 750 mm	1	Blade	Lame	Cuchilla
7	1462201M3	1	X	Tooth	Dent	Diente
8	353915X1	1 5/8" UNF x 2.62"	X	Bolt	Boulon	Perno
9	353427X1	1 5/8" UNF	X	Nut	Écrou	Tuerca
10	862738M1	1 0,8 mm	X	Shim	Cale	Calce
10	862739M1	1 1,6 mm	X	Shim	Cale	Calce



820 860 880 970 980
 TX760B TX860B
 TX870B TX970B

801 802 803 804 805 806 807 808 813 814 815 816 817 821 822 823 824 825 831
 832 833 834 841 842 843 844 845 851 852 853 854 855 921 922 923 931 932

75004C01.1

6199042M3

1



Jan-06

Digger Bucket
 Godet de Défonceuse
 Cuchara retro

Standard
 Standard
 Estándar

305 mm
 305 mm
 305 mm

C-75005-01.1-A

1	3516492M92	305 mm	1	Bucket Assy	Ensemble de godet	Cuchara, Conj.
2		1  Ref.1	1	Bucket	Godet	Cuchara
3	3501770M2	1	2	Bushing	Bague	Anillo
4	3500531M1	1 	1	Edge, Cutting	Lame d'attaque	Cuchilla de ataque
4	3500532M1	1 	1	Edge, Cutting	Lame d'attaque	Cuchilla de ataque
5	353422X1	1 5/8" UNF x 2.0"	4	Bolt	Boulon	Perno
6	353427X1	1 5/8" UNF	4	Nut	Écrou	Tuerca
7	3516498M1	1	1	Blade	Lame	Cuchilla
8	1462201M3	1	3	Tooth	Dent	Diente
9	353915X1	1 5/8" UNF x 2.62"	6	Bolt	Boulon	Perno
10	353427X1	1 5/8" UNF	6	Nut	Écrou	Tuerca
11	862738M1	1 0,8 mm	X	Shim	Cale	Calce
11	862739M1	1 1,6 mm	X	Shim	Cale	Calce

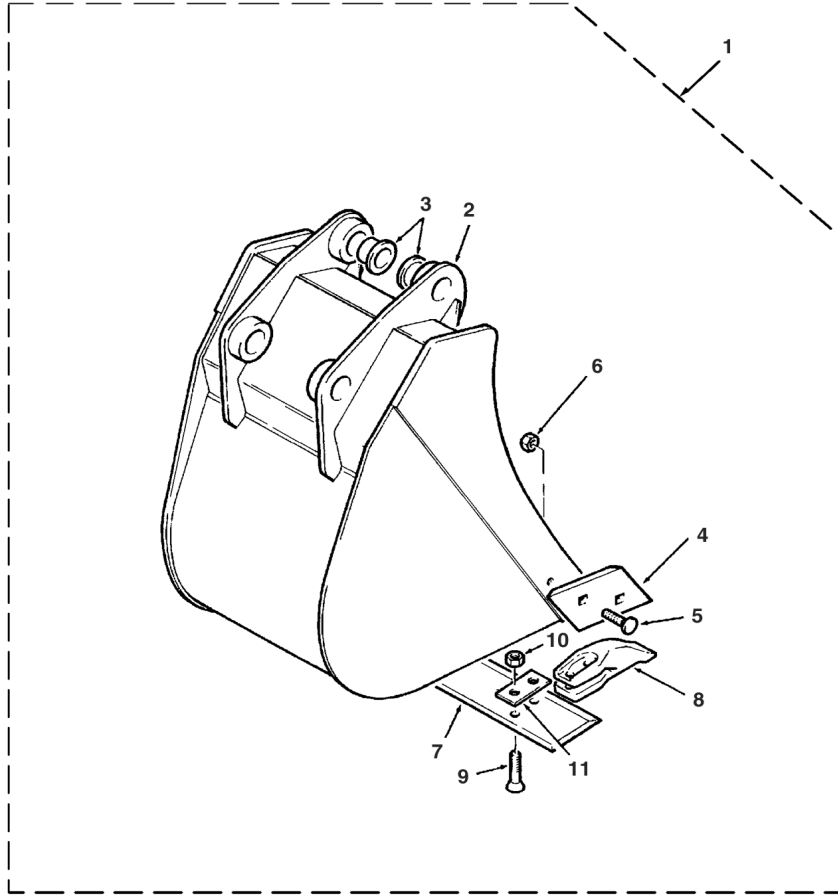

820 860 880 970 980
 TX760B TX860B
 TX870B TX970B

801 802 803 804 805 806 807 808 813 814 815 816 817 821 822 823 824 825 831
 832 833 834 841 842 843 844 845 851 852 853 854 855 921 922 923 931 932

75005C01.1

6199042M3

1

Jan-06

Digger Bucket Linkage
Articulations Godet de Défonceuse
Articulaciones de cuchara retro

AC-74001-01.1-A

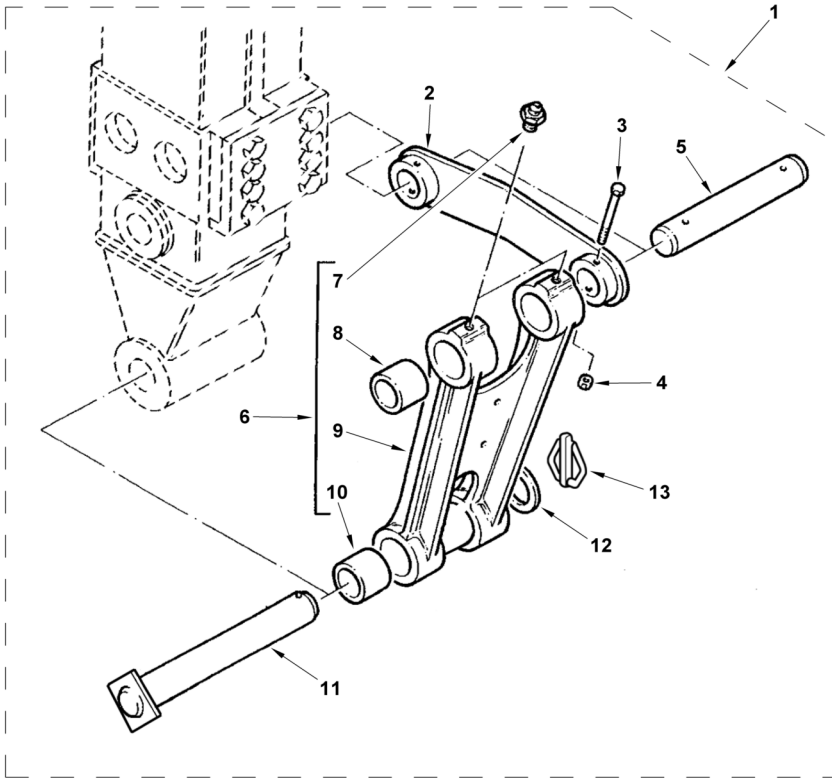

1	ACC15A		Continued Std Dipper & Linkage	1	Accessory code	Code accessoire	Código accesorio
2	3500023M91	1		2	Link Assy	Ensemble de maillon	Eslabón, Conj.
3	1441106X1	1	M10 x 100	4	Screw	Vis	Tornillo
4	1440329X1	1	M10	4	Nut, Lock	Écrou de blocage	Tuerca de retención
5	3522696M2	1	45 x 307 mm	2	Pin	Axe	Pasador
6	3522442M92	1		1	Link Assy	Ensemble de maillon	Eslabón, Conj.
7	339608X1	6		3	Fitting, Grease	Graisseur	Engrasador
8	3500009M3	6		2	Bushing	Bague	Anillo
9		6	➡ Ref. 6	1	Link	Maillon	Eslabón
10	3500009M3	6		2	Bushing	Bague	Anillo
11	3516519M94	1	45 x 302 mm	2	Pin	Axe	Pasador
12	3501790M1	1		2	Washer	Rondelle	Arandela
13	3516522M91	1		2	Pin, Linch	Goupille d'arrêt	Pasador de parada



820 860 880 970 980
 TX760B TX860B
 TX870B TX970B

801 802 803 804 805 806 807 808 809 810 811 812 813 814 815 816 817 821 822
 823 824 825 831 832 833 834 841 842 843 844 845 851 852 853 854 855 921 922
 923 931 932

74001AC01.1

6199042M3

1

Jan-06

Digger Bucket Linkage
Articulations Godet de Défonceuse
Articulaciones de cuchara retro

C-74001-01.1-A

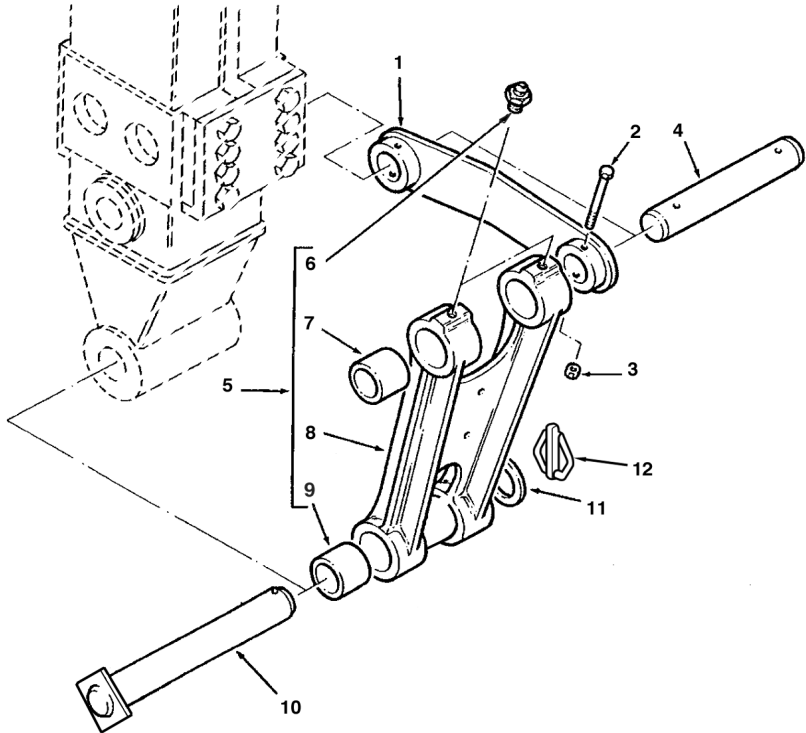

1	3500023M91		2	Link Assy	Ensemble de maillon	Eslabón, Conj.
2	1441106X1	M10 x 100	4	Screw	Vis	Tornillo
3	1440329X1	M10	4	Nut, Lock	Écrou de blocage	Tuerca de retención
4	3522696M2	45 x 307 mm	2	Pin	Axe	Pasador
5	3522442M92		1	Link Assy	Ensemble de maillon	Eslabón, Conj.
6	339608X1	5	3	Fitting, Grease	Graisseur	Engrasador
7	3500009M3	5	2	Bushing	Bague	Anillo
8		5	1	Link	Maillon	Eslabón
9	3500009M3	5	2	Bushing	Bague	Anillo
10	3516519M94	45 x 302 mm	2	Pin	Axe	Pasador
11	3501790M1		2	Washer	Rondelle	Arandela
12	3516522M91		2	Pin, Linch	Goupille d'arrêt	Pasador de parada



820 860 880 970 980
 TX760B TX860B
 TX870B TX970B

801 802 803 804 805 806 807 808 809 810 811 812 813 814 815 816 817 821 822
 823 824 825 831 832 833 834 841 842 843 844 845 851 852 853 854 855 921 922
 923 931 932

74001C01.1

6199042M3

1

Jan-06

Digger Bucket Linkage
Articulations Godet de Défonceuse
Articulaciones de cuchara retro

Case Buckets
Godets Case
Cucharas case

AC-74003-01.1-A

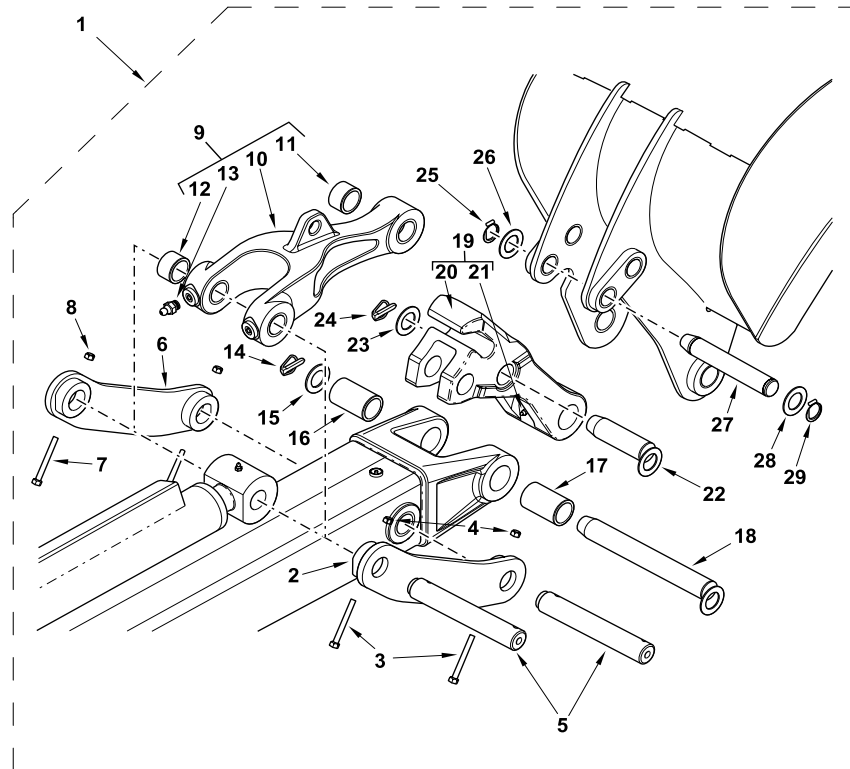

1	ACC16A	Continued Case Dipper & Linkage	1	Accessory code	Code accessoire	Código accesorio
2	6100171M91	1	1	Link Assy	Ensemble de maillon	Eslabón, Conj.
3	1441106X1	1 M10 x 100	2	Screw	Vis	Tornillo
4	1440329X1	1 M10	2	Nut, Lock	Écrou de blocage	Tuerca de retención
5	3522696M2	1 45 x 307 mm	2	Pin	Axe	Pasador
6	6100171M91	1	1	Link Assy	Ensemble de maillon	Eslabón, Conj.
7	1441106X1	1 M10 x 100	2	Screw	Vis	Tornillo
8	1440329X1	1 M10	2	Nut, Lock	Écrou de blocage	Tuerca de retención
9	6100167M92	1	1	Link Assy	Ensemble de maillon	Eslabón, Conj.
10		9	1	Link	Maillon	Eslabón
11	D127172	9	1	Bushing	Bague	Anillo
12	3500009M3	9	2	Bushing	Bague	Anillo
13	339608X1	9	3	Fitting, Grease	Graisseur	Engrasador
14	392181R1	1	1	Pin, Linch	Goupille d'arrêt	Pasador de parada
15	3501790M1	1	1	Washer	Rondelle	Arandela
16	D127168	1	1	Bushing	Bague	Anillo
17	D127168	1	1	Bushing	Bague	Anillo
18	D140655	1 44 x 349 mm	1	Pin Assy	Ensemble d'axe	Pasador, Conj.
19	6101312M91	1	1	Link, Connecting	Maillon de raccord	Eslabón de conexión
20		19	1	Link	Maillon	Eslabón
21	219-1	19	1	Fitting, Grease	Graisseur	Engrasador
22	D140653	1 44 x 152 mm	1	Pin Assy	Ensemble d'axe	Pasador, Conj.
23	3501790M1	1	1	Washer	Rondelle	Arandela
24	392181R1	1	1	Pin, Linch	Goupille d'arrêt	Pasador de parada
25	D25279	1	1	Circlip	Segment d'arrêt	Circlip
26	D143324	1	1	Washer	Rondelle	Arandela
27	D37614	1 1.5" x 9.68"	1	Pin	Axe	Pasador
28	D143324	1	2	Washer	Rondelle	Arandela
29	D25279	1	2	Circlip	Segment d'arrêt	Circlip



820 860 880 970 980
 TX760B TX860B
 TX870B TX970B

801 802 803 804 805 806 807 808 809 810 811 812 813 814 815 816 817 821 822
 823 824 825 831 832 833 834 841 842 843 844 845 851 852 853 854 855 921 922
 923 931 932

74003AC01.1

6199042M3

1

Jan-06

Digger Bucket Linkage
Articulations Godet de Défonceuse
Articulaciones de cuchara retro

Case Buckets
Godets Case
Cucharas case

C-74003-01.1-A

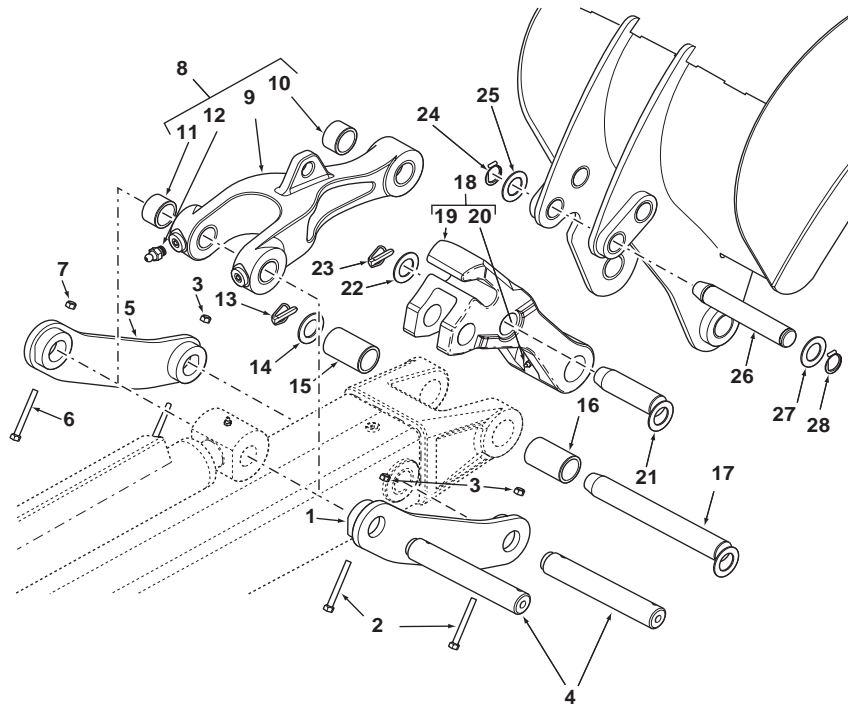

1	6100171M91		1	Link Assy	Ensemble de maillon	Eslabón, Conj.
2	1441106X1	M10 x 100	2	Screw	Vis	Tornillo
3	1440329X1	M10	2	Nut, Lock	Écrou de blocage	Tuerca de retención
4	3522696M2	45 x 307 mm	2	Pin	Axe	Pasador
5	6100171M91		1	Link Assy	Ensemble de maillon	Eslabón, Conj.
6	1441106X1	M10 x 100	2	Screw	Vis	Tornillo
7	1440329X1	M10	2	Nut, Lock	Écrou de blocage	Tuerca de retención
8	6100167M92		1	Link Assy	Ensemble de maillon	Eslabón, Conj.
9		8 Ref. 8	1	Link	Maillon	Eslabón
10	D127172	8	1	Bushing	Bague	Anillo
11	3500009M3	8	2	Bushing	Bague	Anillo
12	339608X1	8	3	Fitting, Grease	Graisser	Engrasador
13	392181R1		1	Pin, Linch	Goupille d'arrêt	Pasador de parada
14	3501790M1		1	Washer	Rondelle	Arandela
15	D127168		1	Bushing	Bague	Anillo
16	D127168		1	Bushing	Bague	Anillo
17	D140655	44 x 349 mm	1	Pin Assy	Ensemble d'axe	Pasador, Conj.
18	6101312M91		1	Link, Connecting	Maillon de raccord	Eslabón de conexión
19		18 Ref. 18	1	Link	Maillon	Eslabón
20	219-1	18	1	Fitting, Grease	Graisser	Engrasador
21	D140653	44 x 152 mm	1	Pin Assy	Ensemble d'axe	Pasador, Conj.
22	3501790M1		1	Washer	Rondelle	Arandela
23	392181R1		1	Pin, Linch	Goupille d'arrêt	Pasador de parada
24	D25279		1	Circlip	Segment d'arrêt	Circlip
25	D143324		1	Washer	Rondelle	Arandela
26	D37614	1.5" x 9.68"	1	Pin	Axe	Pasador
27	D143324		2	Washer	Rondelle	Arandela
28	D25279		2	Circlip	Segment d'arrêt	Circlip



820 860 880 970 980
 TX760B TX860B
 TX870B TX970B

801 802 803 804 805 806 807 808 809 810 811 812 813 814 815 816 817 821 822
 823 824 825 831 832 833 834 841 842 843 844 845 851 852 853 854 855 921 922
 923 931 932

74003C01.1

6199042M3

1

Jan-06

Digger Craning Eye Kit
Coffret de Œillet de Manutention Pour
Défonceuse
Juego de argolla de izado para equipo retro

Sideshift digger
 Montage de pelle latéral
 Excavadora de montaje horizontal

C-98020-01.1-B

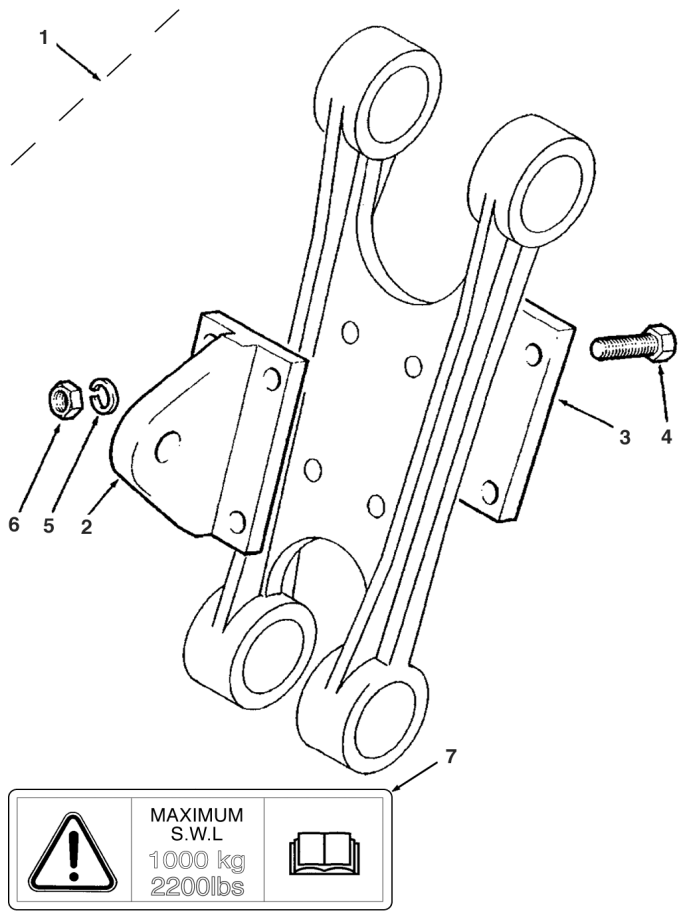

1		(A)	X	Kit, Parts	Lot de pièces	Juego de piezas
2	3517439M91	1	1	Eye	Œil	Ojo
3	3517714M1	1	1	Plate	Plaque	Placa
4	3009511X1	1	M12 x 55	Bolt	Boulon	Perno
5	339369X1	1	M12	Washer, Lock	Rondelle de blocage	Arandela de freno
6	3009695X1	1	M12	Nut	Écrou	Tuerca
7	6102194M1	1	Safe Working	Decal	Adhésif	Adhesivo

A Not serviced - order details
 Non fourni - commander détails
 No suministradas - pedir detalles



820 860 880 970 980
 TX760B TX860B

805 806 807 808 817 825 833 834 845 855 921 931

98020C01.1

6199042M3

1

Jan-06

Digger Craning Eye Kit
Coffret de Œillet de Manutention Pour
Défonceuse
Juego de argolla de izado para equipo retro

Centre mounted digger
 Montage de pelle central
 Excavadora de montaje central

C-98021-01.1-B

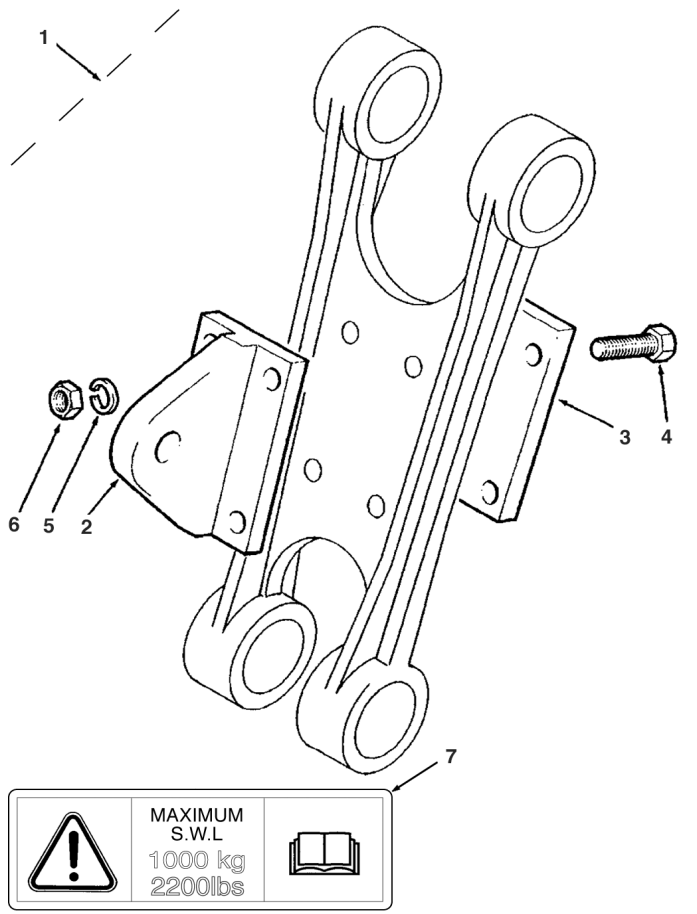

1		(A)	X	Kit, Parts	Lot de pièces	Juego de piezas
2	3511123M92	1	1	Eye	Œil	Ojo
3	3517714M1	1	1	Plate	Plaque	Placa
4	3009511X1	1	M12 x 55	Bolt	Boulon	Perno
5	339369X1	1	M12	Washer, Lock	Rondelle de blocage	Arandela de freno
6	3009695X1	1	M12	Nut	Écrou	Tuerca
7	6102194M1	1	Safe Working	Decal	Adhésif	Adhesivo

A Not serviced - order details
 Non fourni - commander détails
 No suministradas - pedir detalles



820 860 880 970 980
 TX760B TX860B
 TX870B TX970B

801 802 803 804 813 814 815 816 821 822 823 824 831 832 841 842 843 844 851
 852 853 854 922 923 932

Digger Craning Eye Kit
Coffret de Œillet de Manutention Pour
Défonceuse
Juego de argolla de izado para equipo retro

Sideshift digger
 Montage de pelle latéral
 Excavadora de montaje horizontal

JCB
 JCB
 JCB

C-98022-01.1-B

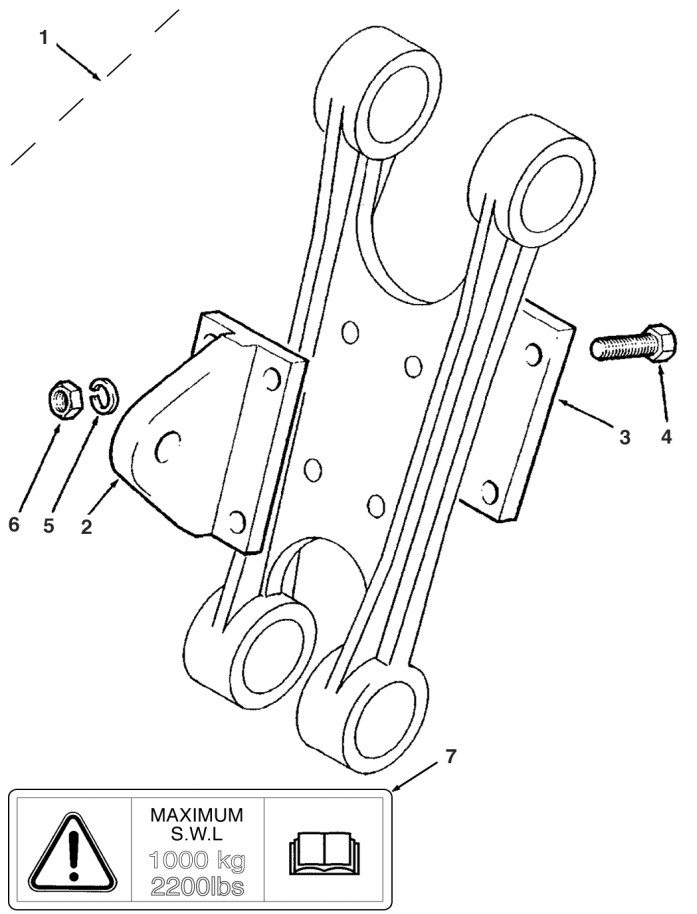

1		(A)	X	Kit, Parts	Lot de pièces	Juego de piezas
2	6108143M91	1	1	Eye	Œil	Ojo
3	6108015M1	1	1	Plate	Plaque	Placa
4	3009511X1	1	M12 x 55	Bolt	Boulon	Perno
5	339369X1	1	M12	Washer, Lock	Rondelle de blocage	Arandela de freno
6	3009695X1	1	M12	Nut	Écrou	Tuerca
7	6102194M1	1	Safe Working	Decal	Adhésif	Adhesivo

A Not serviced - order details
 Non fourni - commander détails
 No suministradas - pedir detalles



820 860 880 970 980
 TX760B TX860B

805 806 807 808 817 825 833 834 845 855 921 931

98022C01.1

6199042M3

1

Jan-06

Digger Craning Eye Kit
Coffret de Œillet de Manutention Pour
Défonceuse
Juego de argolla de izado para equipo retro

Centre mounted digger
 Montage de pelle central
 Excavadora de montaje central

JCB
 JCB
 JCB

C-98023-01.1-B

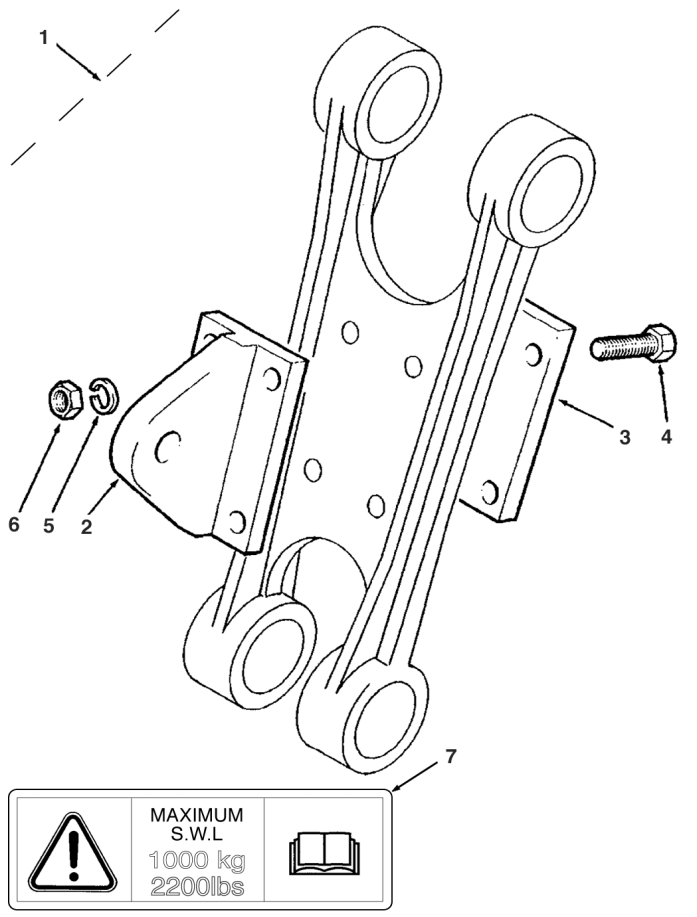

1		(A)	X	Kit, Parts	Lot de pièces	Juego de piezas
2	6108013M91	1	1	Eye	Œil	Ojo
3	6108015M1	1	1	Plate	Plaque	Placa
4	3009511X1	1	M12 x 55	Bolt	Boulon	Perno
5	339369X1	1	M12	Washer, Lock	Rondelle de blocage	Arandela de freno
6	3009695X1	1	M12	Nut	Écrou	Tuerca
7	6102194M1	1	Safe Working	Decal	Adhésif	Adhesivo

A Not serviced - order details
 Non fourni - commander détails
 No suministradas - pedir detalles



820 860 880 970 980
 TX760B TX860B
 TX870B TX970B

801 802 803 804 809 810 811 812 813 814 815 816 821 822 823 824 831 832 841
 842 843 844 851 852 853 854 922 923 932

98023C01.1

6199042M3

1

Jan-06

Dipper
Balancier
Balancín

Extendahoe
Extendahoe
Extendahoe

Bucket Pipework
Tuyauteries Godet
Tubazione di lavoro per benna

AC-76050-01.1-A

1	ACC15A		Continued Std Dipper & Linkage	1	Accessory code	Code accessoire	Código accesorio
2	6102309M91	1		1	Hose Assy	Ensemble de flexible	Flexible, Conj.
3	6107024M91	1		1	Hose Assy	Ensemble de flexible	Flexible, Conj.

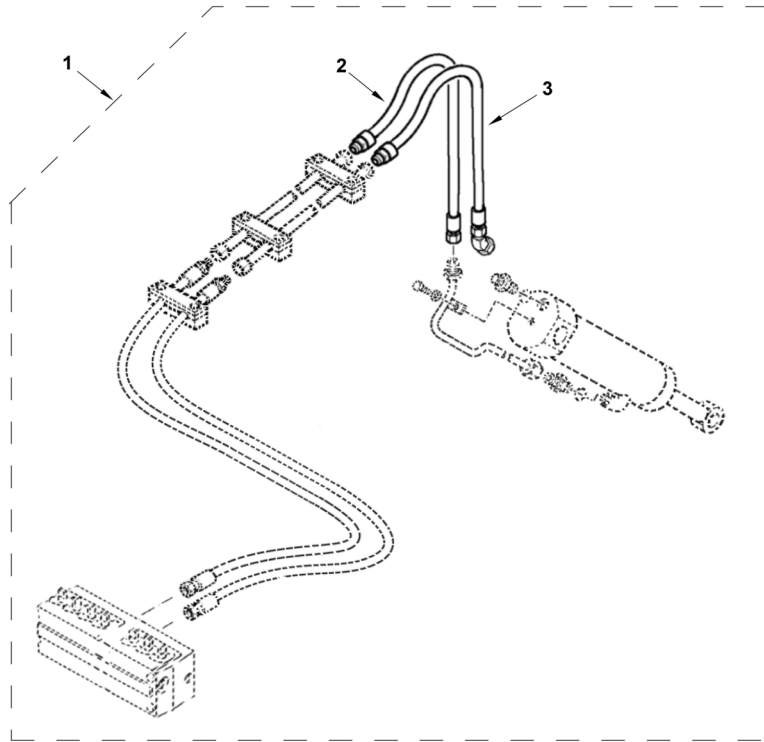

820 860 880 970 980
TX760B TX860B
TX870B TX970B

801 802 803 804 805 806 807 808 809 810 811 812 813 814 815 816 817 821 822
823 824 825 831 832 833 834 841 842 843 844 845 851 852 853 854 855 921 922
923 931 932

76050AC01.1

6199042M3

1

Jan-06

Dipper
Balancier
Balancín

Standard
Standard
Estándar

AC-73001-01.1-A

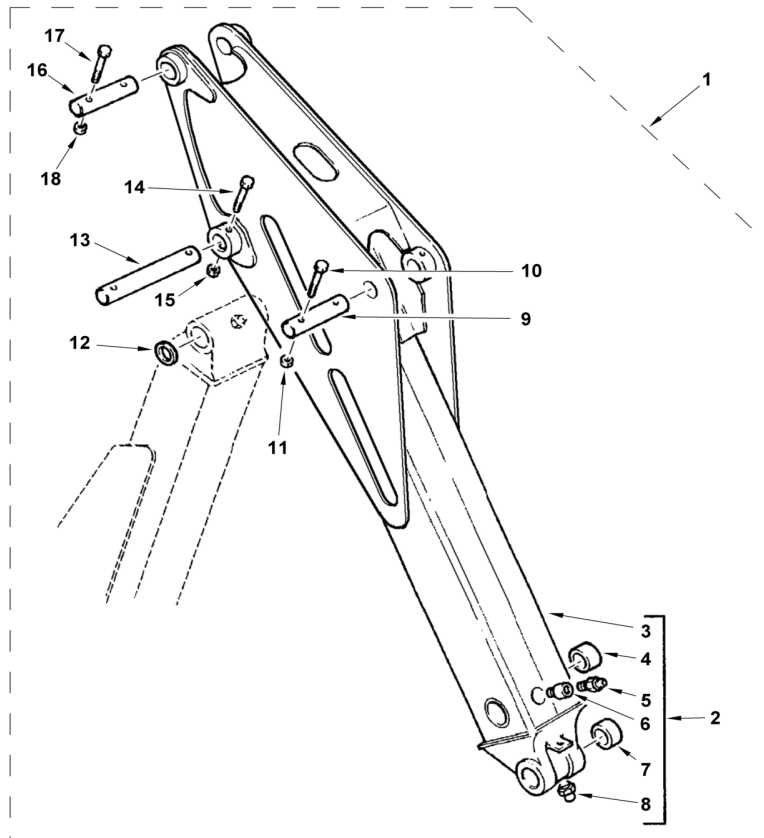

1	ACC15A		Std Dipper & Linkage	1	Accessory code	Code accessoire	Código accesorio
2	6100677M93	1		1	Dipperstick Assy	Ensemble de balancier	Balancín, Conj.
3		2	Ref. 2	1	Dipper	En butte	Balancín
4	3500009M3	2		2	Bushing	Bague	Anillo
5	339608X1	2		1	Fitting, Grease	Graisseur	Engrasador
6	3504012M1	2		1	Adaptor	Adaptateur	Adaptador
7	3500009M3	2		2	Bushing	Bague	Anillo
8	339608X1	2		1	Fitting, Grease	Graisseur	Engrasador
9	3522694M2	1	45 x 230 mm	1	Pin	Axe	Pasador
10	3501289M1	1	M10 x 110	1	Screw	Vis	Tornillo
11	1440329X1	1	M10	1	Nut, Lock	Écrou de blocage	Tuerca de retención
12	3501027M1	1		2	Washer	Rondelle	Arandela
13	3522693M2	1	45 x 310 mm	1	Pin	Axe	Pasador
14	3501289M1	1	M10 x 110	2	Screw	Vis	Tornillo
15	1440329X1	1	M10	2	Nut, Lock	Écrou de blocage	Tuerca de retención
16	3522693M2	1	45 x 310 mm	1	Pin	Axe	Pasador
17	3501289M1	1	M10 x 110	2	Screw	Vis	Tornillo
18	1440329X1	1	M10	2	Nut, Lock	Écrou de blocage	Tuerca de retención



820 860 880 970 980
TX760B TX860B
TX870B TX970B

801 802 803 804 805 806 807 808 809 810 811 812 813 814 815 816 817 821 822
823 824 825 831 832 833 834 841 842 843 844 845 851 852 853 854 855 921 922
923 931 932

73001AC01.1

6199042M3

1

Jan-06

Dipper
Balancier
Balancín

Standard
Standard
Estándar

C-73001-01.1-A

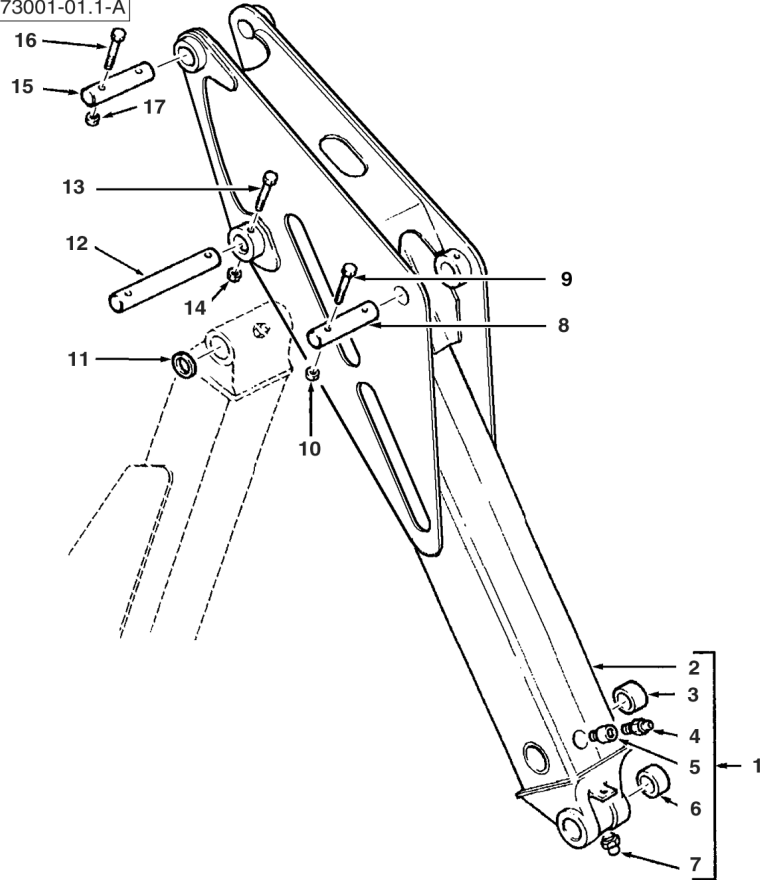

1	6100677M93		1	Dipperstick Assy	Ensemble de balancier	Balancín, Conj.
2		1	▶ Ref. 1	Dipper	En butte	Balancín
3	3500009M3	1		Bushing	Bague	Anillo
4	339608X1	1		Fitting, Grease	Graisser	Engrasador
5	3504012M1	1		Adaptor	Adaptateur	Adaptador
6	3500009M3	1		Bushing	Bague	Anillo
7	339608X1	1		Fitting, Grease	Graisser	Engrasador
8	3522694M2	45 x 230 mm	1	Pin	Axe	Pasador
9	3501289M1	M10 x 110	1	Screw	Vis	Tornillo
10	1440329X1	M10	1	Nut, Lock	Écrou de blocage	Tuerca de retención
11	3501027M1		2	Washer	Rondelle	Arandela
12	3522693M2	45 x 310 mm	1	Pin	Axe	Pasador
13	3501289M1	M10 x 110	2	Screw	Vis	Tornillo
14	1440329X1	M10	2	Nut, Lock	Écrou de blocage	Tuerca de retención
15	3522693M2	45 x 310 mm	1	Pin	Axe	Pasador
16	3501289M1	M10 x 110	2	Screw	Vis	Tornillo
17	1440329X1	M10	2	Nut, Lock	Écrou de blocage	Tuerca de retención



820 860 880 970 980
TX760B TX860B
TX870B TX970B

801 802 803 804 805 806 807 808 809 810 811 812 813 814 815 816 817 821 822
823 824 825 831 832 833 834 841 842 843 844 845 851 852 853 854 855 921 922
923 931 932

73001C01.1

6199042M3

1

Jan-06

Dipper
Balancier
Balancín

Standard
Standard
Estándar

Case Bucket
Godet Case
Cuchara de superficie

AC-73003-01.1-A

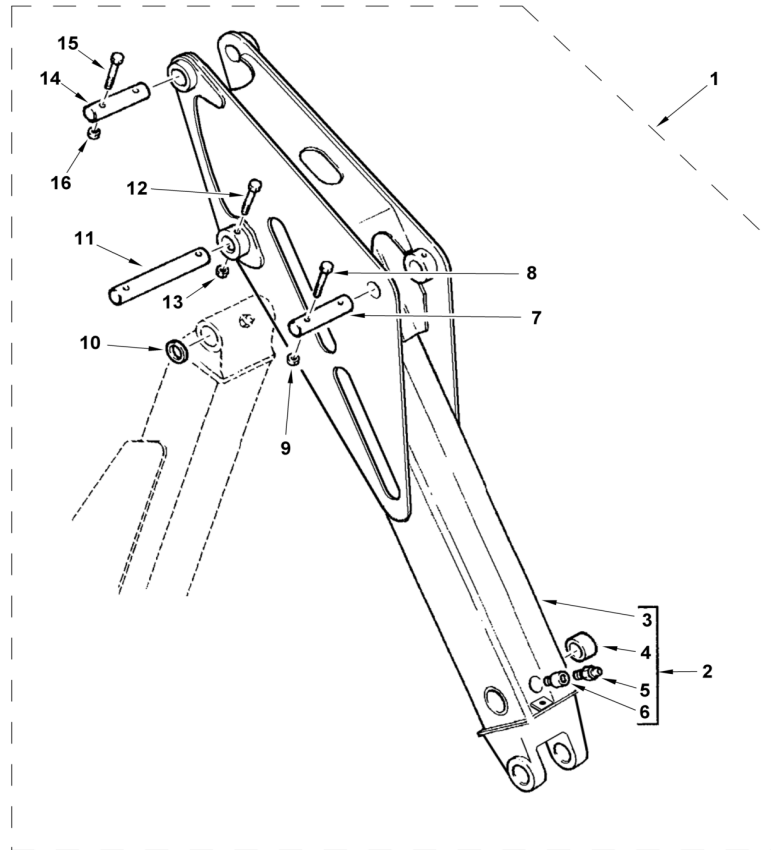

1	ACC16A		Case Dipper & Linkage	1	Accessory code	Code accessoire	Código accesorio
2	6100818M93	1		1	Dipperstick Assy	Ensemble de balancier	Balancín, Conj.
3		2	Ref. 2	1	Dipper	En butte	Balancín
4	3500009M3	2		2	Bushing	Bague	Anillo
5	339608X1	2		1	Fitting, Grease	Graisseur	Engrasador
6	3504012M1	2		1	Adaptor	Adaptateur	Adaptador
7	3522694M2	1	45 x 230 mm	1	Pin	Axe	Pasador
8	3501289M1	1	M10 x 110	1	Screw	Vis	Tornillo
9	1440329X1	1	M10	1	Nut, Lock	Écrou de blocage	Tuerca de retención
10	3501027M1	1		2	Washer	Rondelle	Arandela
11	3522693M2	1	45 x 310 mm	1	Pin	Axe	Pasador
12	3501289M1	1	M10 x 110	2	Screw	Vis	Tornillo
13	1440329X1	1	M10	2	Nut, Lock	Écrou de blocage	Tuerca de retención
14	3522693M2	1	45 x 310 mm	1	Pin	Axe	Pasador
15	3501289M1	1	M10 x 110	2	Screw	Vis	Tornillo
16	1440329X1	1	M10	2	Nut, Lock	Écrou de blocage	Tuerca de retención



820 860 880 970 980
TX760B TX860B
TX870B TX970B

801 802 803 804 805 806 807 808 809 810 811 812 813 814 815 816 817 821 822
823 824 825 831 832 833 834 841 842 843 844 845 851 852 853 854 855 921 922
923 931 932

73003AC01.1

6199042M3

1

Jan-06

Dipper
Balancier
Balancín

Standard
Standard
Estándar

Case Bucket
Godet Case
Cuchara de superficie

C-73003-01.1-A

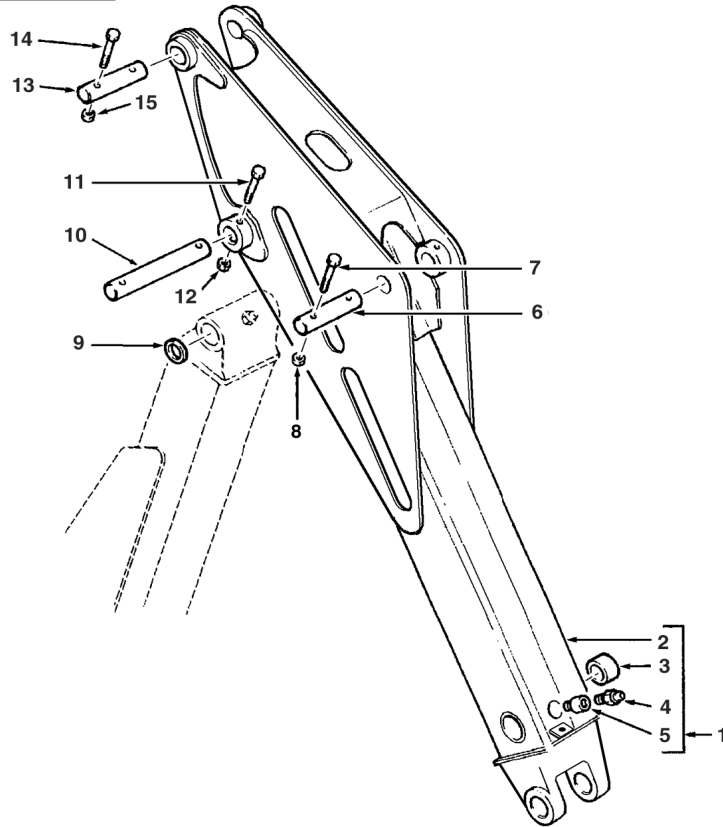

1	6100818M93		1	Dipperstick Assy	Ensemble de balancier	Balancín, Conj.
2		1	▶ Ref. 1	Dipper	En butte	Balancín
3	3500009M3	1		Bushing	Bague	Anillo
4	339608X1	1		Fitting, Grease	Graisneur	Engrasador
5	3504012M1	1		Adaptor	Adaptateur	Adaptador
6	3522694M2	45 x 230 mm	1	Pin	Axe	Pasador
7	3501289M1	M10 x 110	1	Screw	Vis	Tornillo
8	1440329X1	M10	1	Nut, Lock	Écrou de blocage	Tuerca de retención
9	3501027M1		2	Washer	Rondelle	Arandela
10	3522693M2	45 x 310 mm	1	Pin	Axe	Pasador
11	3501289M1	M10 x 110	2	Screw	Vis	Tornillo
12	1440329X1	M10	2	Nut, Lock	Écrou de blocage	Tuerca de retención
13	3522693M2	45 x 310 mm	1	Pin	Axe	Pasador
14	3501289M1	M10 x 110	2	Screw	Vis	Tornillo
15	1440329X1	M10	2	Nut, Lock	Écrou de blocage	Tuerca de retención



820 860 880 970 980
TX760B TX860B
TX870B TX970B

801 802 803 804 805 806 807 808 809 810 811 812 813 814 815 816 817 821 822
823 824 825 831 832 833 834 841 842 843 844 845 851 852 853 854 855 921 922
923 931 932

73003C01.1

6199042M3

1

Jan-06

Engine block heater
Réchauffeur bloc moteur
Calentador del bloque del motor

1	6110608M91	Engine block	1	Heater	Chauffage	Calentador
---	------------	--------------	---	--------	-----------	------------

Not Illustrated

Non Illustrée

Nicht Abgebildet

Non Illustrato

No Ilustrado



880 980
TX860B TX870B
TX970B

841 842 843 844 845 851 852 853 854 855 931 932

Extendahoe Hydraulics Kit
Coffret de Circuit Hydraulique Extendahoe
Juego de circuito hidráulico Extendahoe

Centremount
Montage Pelle Central
Excavadora de montaje central

Without Auxiliary Hydraulics
 Sans Hydraulique Auxiliaire
 Sin hidraulico auxiliar

4.5m
 4.5m
 4.5m

C-98063-01.1-A

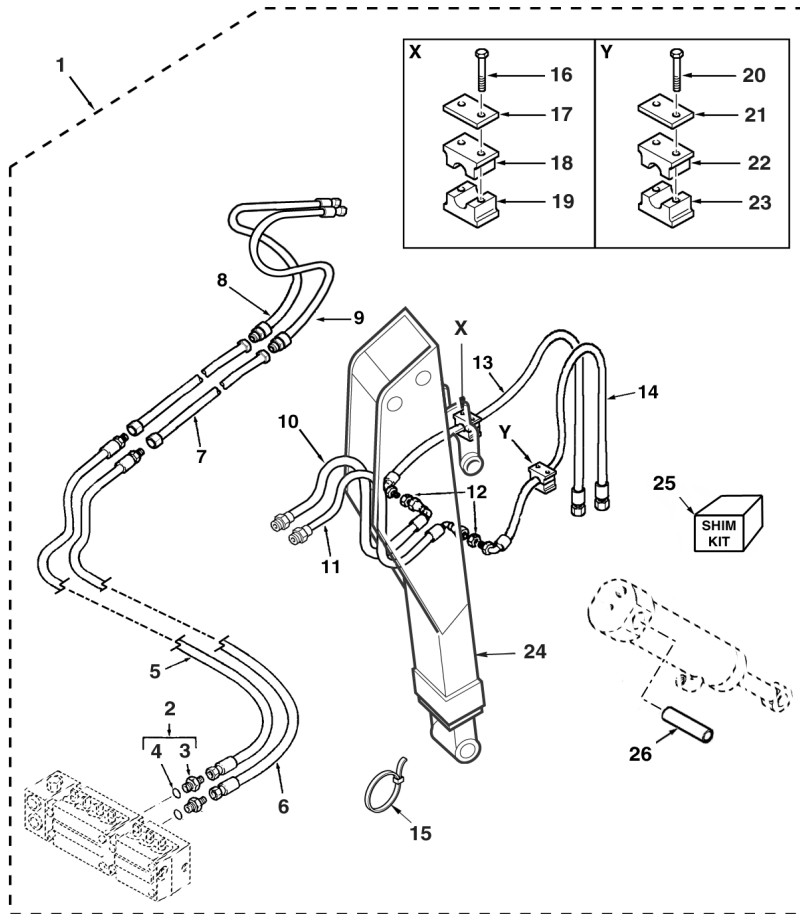

1	6110171M91	(A)	1	Kit, Conversion	Jeu Conversion	Juego de conversion
2	365715X91	1, 1/16" - 7/8" UNF	2	Connector Assy	Ensemble connexion	Conexión, Conj.
3		Ref. 2	1	Connector	Connecteur	Conector
4	835025M1		1	O-Ring	Joint torique	Junta de tipo O
5	6107464M93		1	Hose Assy	Ensemble de flexible	Flexible, Conj.
6	6107465M92		1	Hose Assy	Ensemble de flexible	Flexible, Conj.
7	6101773M91		2	Tube Assy	Tuyauterie	Conjunto de tubería
8	6101741M91	Dark Green	1	Hose Assy	Ensemble de flexible	Flexible, Conj.
9	6101757M91	Black	1	Hose Assy	Ensemble de flexible	Flexible, Conj.
10	6101739M91	Brown	1	Hose Assy	Ensemble de flexible	Flexible, Conj.
11	6101740M91	White	1	Hose Assy	Ensemble de flexible	Flexible, Conj.
12	355574X1		2	Nut	Écrou	Tuerca
13	6101007M91	Brown	1	Hose Assy	Ensemble de flexible	Flexible, Conj.
14	6101008M91	White	1	Hose Assy	Ensemble de flexible	Flexible, Conj.
15	1664405M1		2	Tie, Cable	Attache câble	Enlace de Cable
16	339229X1	M6 x 40	2	Screw	Vis	Tornillo
17	1462583M1		1	Plate	Plaque	Placa
18	6102170M1		1	Bracket, Clamp	Bride de fixation	Brida de fijación
19	6102170M1		1	Bracket, Clamp	Bride de fixation	Brida de fijación
20	339229X1	M6 x 40	2	Screw	Vis	Tornillo
21	1462583M1		1	Plate	Plaque	Placa
22	6102788M1		1	Bracket, Clamp	Bride de fixation	Brida de fijación
23	6102788M1		1	Bracket, Clamp	Bride de fixation	Brida de fijación
24	6109586M91		1	Dipperstick Assy	Ensemble de balancier	Balancín, Conj.
25	3510860M91		1	Kit, Shim	Jeu de cales	Juego de calces
26	3522720M2	45 x 250 mm	1	Pin	Axe	Pasador

A Without Quick Attach
 Sans attache rapide
 Sin acoplamiento rápido



820 860 880 970
 TX760B TX860B

801 802 803 804 809 810 813 814 821 822 831 832 841 842 851 852 922

98063C01.1

6199042M3

1

Jan-06

Extendahoe Hydraulics Kit
Coffret de Circuit Hydraulique Extendahoe
Juego de circuito hidráulico Extendahoe

Centremount
Montage Pelle Central
Excavadora de montaje central

Control Pedal
 Pédale de Commande
 Pedal de control

4.5m
 4.5m
 4.5m

C-98063-02.1-A

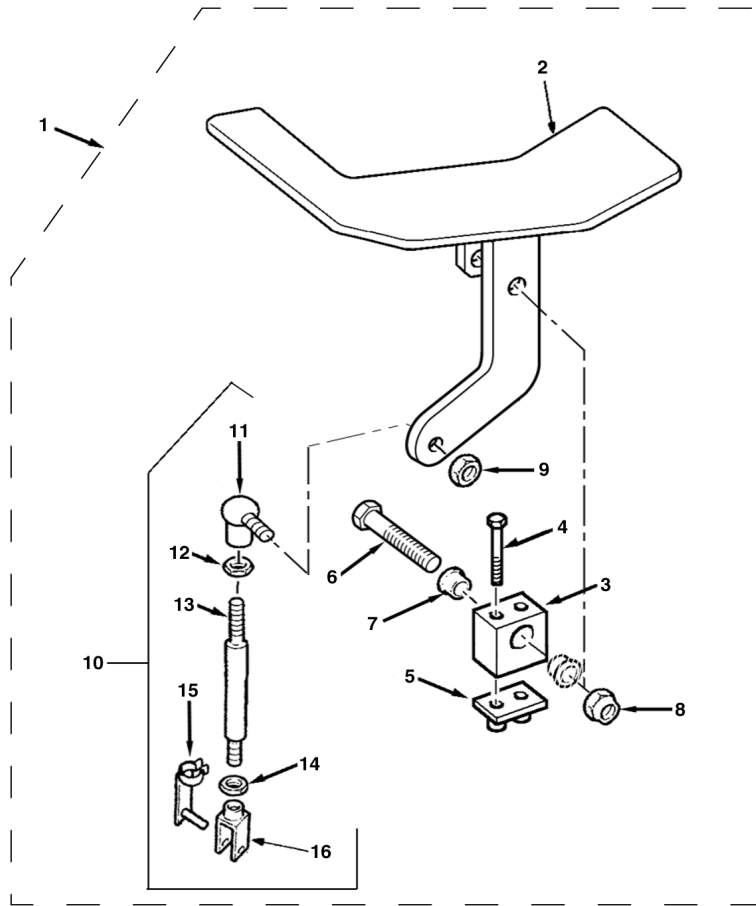

1	6110171M91		(A)Continued	1	Kit, Conversion	Jeu Conversion	Juego de conversión
2	6106874M91	1		1	Pedal Assy	Ensemble de pédale	Pedal, Conj.
3	6106734M1	1		1	Pivot	Pivot	Pivote
4	3001758X1	1	M6 x 50	2	Screw	Vis	Tornillo
5	3519538M1	1		1	Plate, Base	Plaque de base	Placa de base
6	6106981M1	1	M10 x 60	1	Bolt	Boulon	Perno
7	6106866M1	1		1	Bushing	Bague	Anillo
8	1440329X1	1	M10	1	Nut, Lock	Écrou de blocage	Tuerca de retención
9	394367X1	1	M8	1	Nut, Lock	Écrou de blocage	Tuerca de retención
10	6106724M92	1		1	Rod Assy	Ensemble tringlerie	Tirantes, Conj.
11	3517518M1	10		1	Ball Joint	Rotule	Rotula
12	339169X1	10	M8	1	Nut	Écrou	Tuerca
13		10	➔ Ref. 10	1	Rod	Tringle	Vástago
14	3519650M1	10	M8 LH Thread	1	Nut	Écrou	Tuerca
15	3520666M1	10		1	Pin, Clevis	Axe de chape	Eje de brida
16	3519590M1	10	LH Thread	1	Clevis	Chape	Brida
17	6101865M2	1		1	Decal	Adhésif	Adhesivo

A Without Quick Attach
 Sans attache rapide
 Sin acoplamiento rápido



820 860 880 970
 TX760B TX860B

801 802 803 804 809 810 813 814 821 822 831 832 841 842 851 852 922

98063C02.1

6199042M3

1

Jan-06

Extendahoe Hydraulics Kit
Coffret de Circuit Hydraulique Extendahoe
Juego de circuito hidráulico Extendahoe

Centremount
Montage Pelle Central
Excavadora de montaje central

Without Auxiliary Hydraulics
 Sans Hydraulique Auxiliaire
 Sin hidraulico auxiliar

4.5m
 4.5m
 4.5m

C-98064-01.1-A

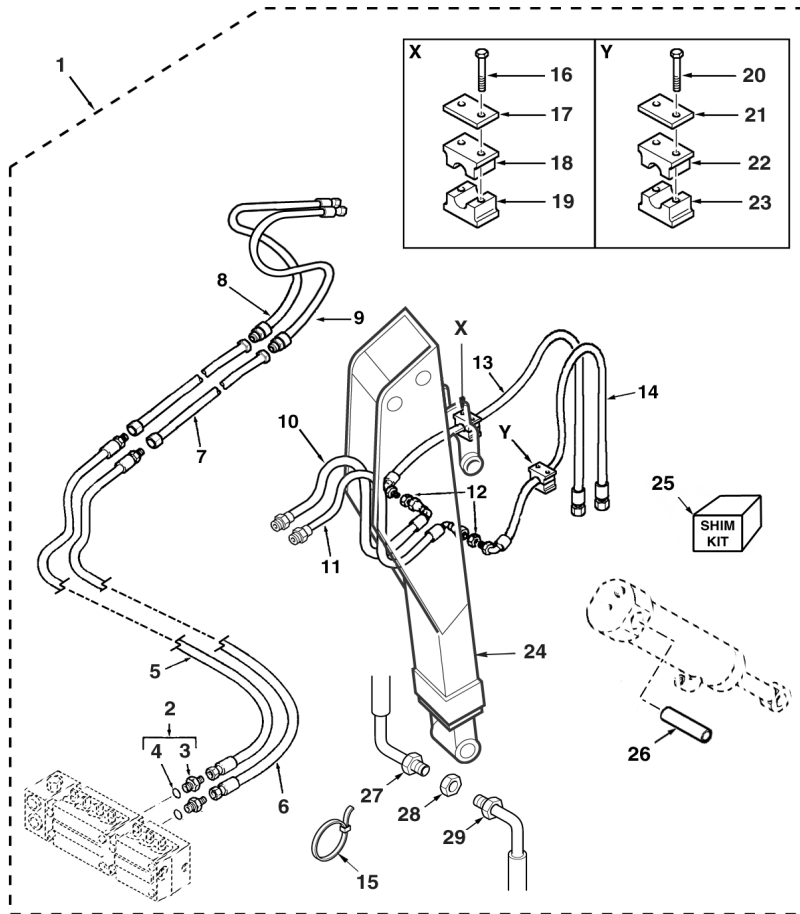

1	6110172M91		(A)	1	Kit, Conversion	Jeu Conversion	Juego de conversion
2	365715X91	1	1,1/16" - 7/8" UNF	2	Connector Assy	Ensemble connexion	Conexión, Conj.
3		2	Ref. 2	1	Connector	Connecteur	Conector
4	835025M1	2		1	O-Ring	Joint torique	Junta de tipo O
5	6107464M93	1		1	Hose Assy	Ensemble de flexible	Flexible, Conj.
6	6107465M92	1		1	Hose Assy	Ensemble de flexible	Flexible, Conj.
7	6101773M91	1		2	Tube Assy	Tuyauterie	Conjunto de tubería
8	6101741M91	1	Dark Green	1	Hose Assy	Ensemble de flexible	Flexible, Conj.
9	6101757M91	1	Black	1	Hose Assy	Ensemble de flexible	Flexible, Conj.
10	6101739M91	1	Brown	1	Hose Assy	Ensemble de flexible	Flexible, Conj.
11	6101740M91	1	White	1	Hose Assy	Ensemble de flexible	Flexible, Conj.
12	355574X1	1		2	Nut	Écrou	Tuerca
13	6101007M91	1	Brown	1	Hose Assy	Ensemble de flexible	Flexible, Conj.
14	6101008M91	1	White	1	Hose Assy	Ensemble de flexible	Flexible, Conj.
15	1664405M1	1		5	Tie, Cable	Attache câble	Enlace de Cable
16	339229X1	1	M6 x 40	2	Screw	Vis	Tornillo
17	1462583M1	1		1	Plate	Plaque	Placa
18	6102170M1	1		1	Bracket, Clamp	Bride de fixation	Brida de fijación
19	6102170M1	1		1	Bracket, Clamp	Bride de fixation	Brida de fijación
20	339229X1	1	M6 x 40	2	Screw	Vis	Tornillo
21	1462583M1	1		1	Plate	Plaque	Placa
22	6102788M1	1		1	Bracket, Clamp	Bride de fixation	Brida de fijación
23	6102788M1	1		1	Bracket, Clamp	Bride de fixation	Brida de fijación
24	6109586M91	1		1	Dipperstick Assy	Ensemble de balancier	Balancín, Conj.
25	3510860M91	1		1	Kit, Shim	Jeu de cales	Juego de calces
26	3522720M2	1	45 x 250 mm	1	Pin	Axe	Pasador
27	3521945M95	1		2	Hose Assy	Ensemble de flexible	Flexible, Conj.
28	356612X1	1	7/16" UNF	2	Nut	Écrou	Tuerca
29	6102922M91	1		2	Hose Assy	Ensemble de flexible	Flexible, Conj.

A With Quick Attach
 Avec attache rapide
 Con acoplamiento rápido



820 860 880 970
 TX760B TX860B

801 802 803 804 809 810 813 814 821 822 831 832 841 842 851 852 922

98064C01.1

6199042M3

1

Jan-06

Extendahoe Hydraulics Kit
Coffret de Circuit Hydraulique Extendahoe
Juego de circuito hidráulico Extendahoe

Centremount
Montage Pelle Central
Excavadora de montaje central

Control Pedal
 Pédale de Commande
 Pedal de control

4.5m
 4.5m
 4.5m

C-98064-02.1-A

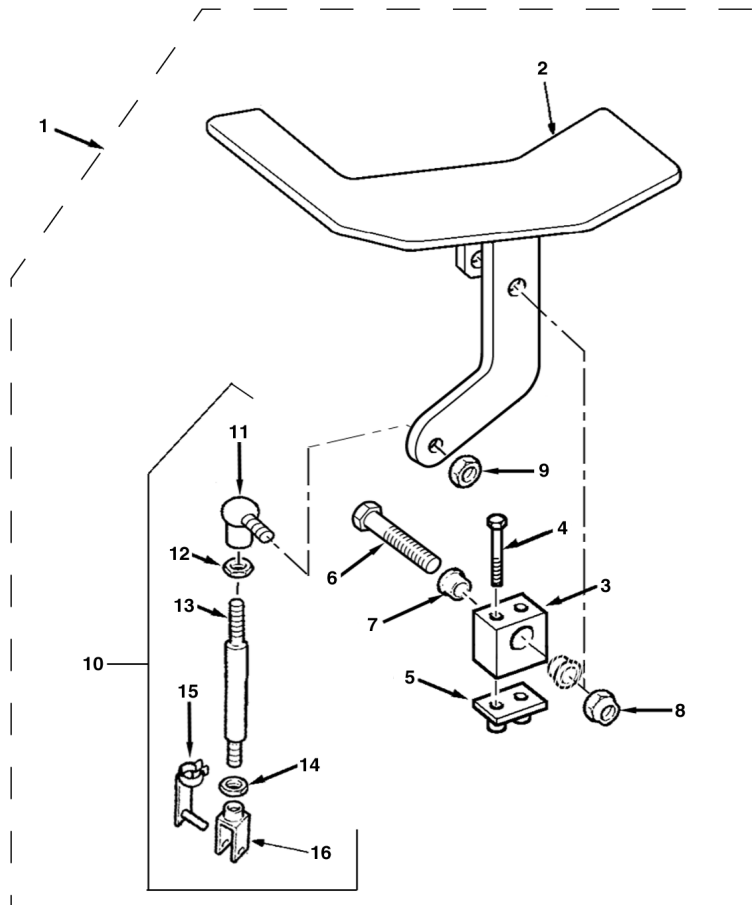

1	6110172M91		(A)Continued	1	Kit, Conversion	Jeu Conversion	Juego de conversion
2	6106874M91	1		1	Pedal Assy	Ensemble de pédale	Pedal, Conj.
3	6106734M1	1		1	Pivot	Pivot	Pivote
4	3001758X1	1	M6 x 50	2	Screw	Vis	Tornillo
5	3519538M1	1		1	Plate, Base	Plaque de base	Placa de base
6	6106981M1	1	M10 x 60	1	Bolt	Boulon	Perno
7	6106866M1	1		1	Bushing	Bague	Anillo
8	1440329X1	1	M10	1	Nut, Lock	Écrou de blocage	Tuerca de retención
9	394367X1	1	M8	1	Nut, Lock	Écrou de blocage	Tuerca de retención
10	6106724M92	1		1	Rod Assy	Ensemble tringlerie	Tirantes, Conj.
11	3517518M1	10		1	Ball Joint	Rotule	Rotula
12	339169X1	10	M8	1	Nut	Écrou	Tuerca
13		10	➡ Ref. 10	1	Rod	Tringle	Vástago
14	3519650M1	10	LH Thread M8 LH Thread	1	Nut	Écrou	Tuerca
15	3520666M1	10		1	Pin, Clevis	Axe de chape	Eje de brida
16	3519590M1	10	LH Thread LH Thread	1	Clevis	Chape	Brida
17	6101865M2	1		1	Decal	Adhésif	Adhesivo

A With Quick Attach
 Avec attache rapide
 Con acoplamiento rápido



820 860 880 970
 TX760B TX860B

801 802 803 804 809 810 813 814 821 822 831 832 841 842 851 852 922

98064C02.1

6199042M3

1

Jan-06

Extendahoe Hydraulics Kit
Coffret de Circuit Hydraulique Extendahoe
Juego de circuito hidráulico Extendahoe

Centremount
Montage Pelle Central
Excavadora de montaje central

Without Auxiliary Hydraulics
 Sans Hydraulique Auxiliaire
 Sin hidraulico auxiliar

4.9m
 4.9m
 4.9m

C-98065-01.1-A

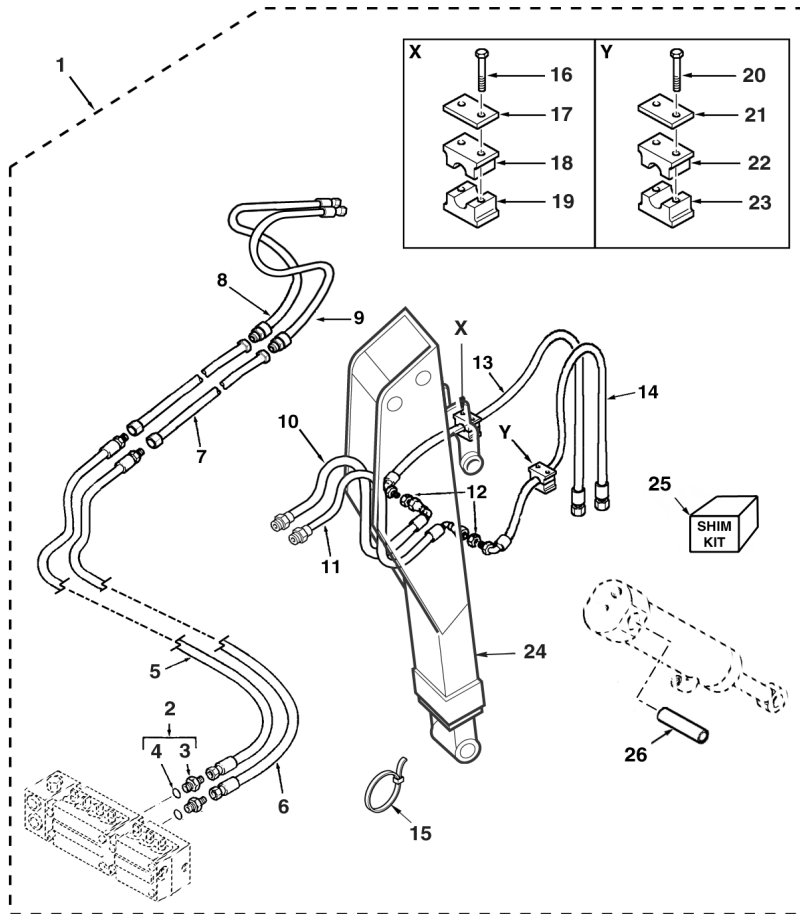

1	6110173M91	(A)	1	Kit, Conversion	Jeu Conversion	Juego de conversion
2	365715X91	1, 1/16" - 7/8" UNF	2	Connector Assy	Ensemble connexion	Conexión, Conj.
3		Ref. 2	1	Connector	Connecteur	Conector
4	835025M1		1	O-Ring	Joint torique	Junta de tipo O
5	6107464M93		1	Hose Assy	Ensemble de flexible	Flexible, Conj.
6	6107465M92		1	Hose Assy	Ensemble de flexible	Flexible, Conj.
7	6101734M91		2	Tube Assy	Tuyauterie	Conjunto de tubería
8	6101741M91	Dark Green	1	Hose Assy	Ensemble de flexible	Flexible, Conj.
9	6101757M91	Black	1	Hose Assy	Ensemble de flexible	Flexible, Conj.
10	6101739M91	Brown	1	Hose Assy	Ensemble de flexible	Flexible, Conj.
11	6101740M91	White	1	Hose Assy	Ensemble de flexible	Flexible, Conj.
12	355574X1		2	Nut	Écrou	Tuerca
13	6101007M91	Brown	1	Hose Assy	Ensemble de flexible	Flexible, Conj.
14	6101008M91	White	1	Hose Assy	Ensemble de flexible	Flexible, Conj.
15	1664405M1		2	Tie, Cable	Attache câble	Enlace de Cable
16	339229X1	M6 x 40	2	Screw	Vis	Tornillo
17	1462583M1		1	Plate	Plaque	Placa
18	6102170M1		1	Bracket, Clamp	Bride de fixation	Brida de fijación
19	6102170M1		1	Bracket, Clamp	Bride de fixation	Brida de fijación
20	339229X1	M6 x 40	2	Screw	Vis	Tornillo
21	1462583M1		1	Plate	Plaque	Placa
22	6102788M1		1	Bracket, Clamp	Bride de fixation	Brida de fijación
23	6102788M1		1	Bracket, Clamp	Bride de fixation	Brida de fijación
24	6109586M91		1	Dipperstick Assy	Ensemble de balancier	Balancín, Conj.
25	3510860M91		1	Kit, Shim	Jeu de cales	Juego de calces
26	3522720M2	45 x 250 mm	1	Pin	Axe	Pasador

A Without Quick Attach
 Sans attache rapide
 Sin acoplamiento rápido



860 880 970 980
 TX870B TX970B

811 812 815 816 823 824 843 844 853 854 923 932

98065C01.1

6199042M3

1

Jan-06

Extendahoe Hydraulics Kit
Coffret de Circuit Hydraulique Extendahoe
Juego de circuito hidráulico Extendahoe

Centremount
Montage Pelle Central
Excavadora de montaje central

Control Pedal
 Pédale de Commande
 Pedal de control

4.9m
 4.9m
 4.9m

C-98065-02.1-A

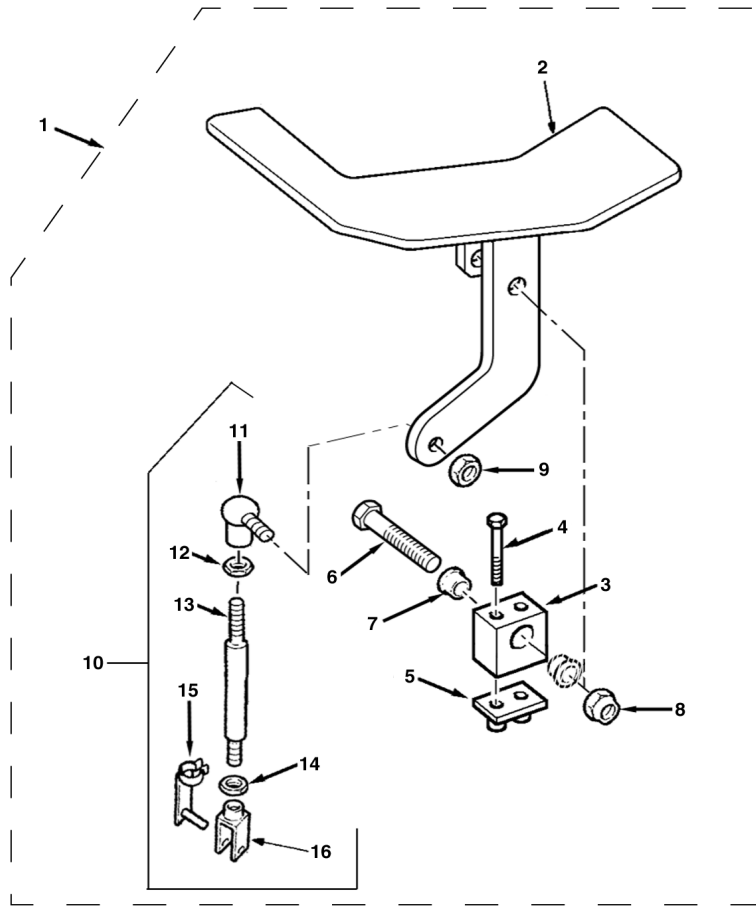

1	6110173M91		(A)Continued	1	Kit, Conversion	Jeu Conversion	Juego de conversión
2	6106874M91	1		1	Pedal Assy	Ensemble de pédale	Pedal, Conj.
3	6106734M1	1		1	Pivot	Pivot	Pivote
4	3001758X1	1	M6 x 50	2	Screw	Vis	Tornillo
5	3519538M1	1		1	Plate, Base	Plaque de base	Placa de base
6	6106981M1	1	M10 x 60	1	Bolt	Boulon	Perno
7	6106866M1	1		1	Bushing	Bague	Anillo
8	1440329X1	1	M10	1	Nut, Lock	Écrou de blocage	Tuerca de retención
9	394367X1	1	M8	1	Nut, Lock	Écrou de blocage	Tuerca de retención
10	6106724M92	1		1	Rod Assy	Ensemble tringlerie	Tirantes, Conj.
11	3517518M1	10		1	Ball Joint	Rotule	Rotula
12	339169X1	10	M8	1	Nut	Écrou	Tuerca
13		10	➔ Ref. 10	1	Rod	Tringle	Vástago
14	3519650M1	10	M8 LH Thread	1	Nut	Écrou	Tuerca
15	3520666M1	10		1	Pin, Clevis	Axe de chape	Eje de brida
16	3519590M1	10	LH Thread	1	Clevis	Chape	Brida
17	6101865M2	1		1	Decal	Adhésif	Adhesivo

A Without Quick Attach
 Sans attache rapide
 Sin acoplamiento rápido



860 880 970 980
 TX870B TX970B

811 812 815 816 823 824 843 844 853 854 923 932

98065C02.1

6199042M3

1

Jan-06

Extendahoe Hydraulics Kit
Coffret de Circuit Hydraulique Extendahoe
Juego de circuito hidráulico Extendahoe

Centremount
Montage Pelle Central
Excavadora de montaje central

Without Auxiliary Hydraulics
 Sans Hydraulique Auxiliaire
 Sin hidraulico auxiliar

4.9m
 4.9m
 4.9m

C-98066-01.1-A

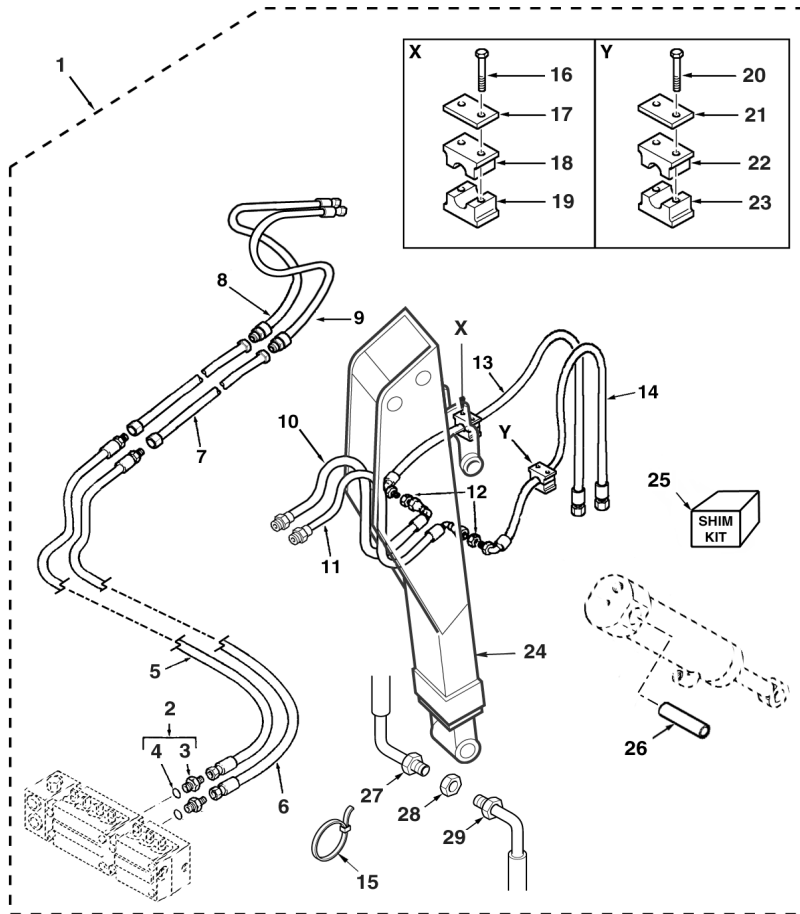

1	6110174M91		(A)	1	Kit, Conversion	Jeu Conversion	Juego de conversion
2	365715X91	1	1,1/16" - 7/8" UNF	2	Connector Assy	Ensemble connexion	Conexión, Conj.
3		2	Ref. 2	1	Connector	Connecteur	Conector
4	835025M1	2		1	O-Ring	Joint torique	Junta de tipo O
5	6107464M93	1		1	Hose Assy	Ensemble de flexible	Flexible, Conj.
6	6107465M92	1		1	Hose Assy	Ensemble de flexible	Flexible, Conj.
7	6101734M91	1		2	Tube Assy	Tuyauterie	Conjunto de tubería
8	6101741M91	1	Dark Green	1	Hose Assy	Ensemble de flexible	Flexible, Conj.
9	6101757M91	1	Black	1	Hose Assy	Ensemble de flexible	Flexible, Conj.
10	6101739M91	1	Brown	1	Hose Assy	Ensemble de flexible	Flexible, Conj.
11	6101740M91	1	White	1	Hose Assy	Ensemble de flexible	Flexible, Conj.
12	355574X1	1		2	Nut	Écrou	Tuerca
13	6101007M91	1	Brown	1	Hose Assy	Ensemble de flexible	Flexible, Conj.
14	6101008M91	1	White	1	Hose Assy	Ensemble de flexible	Flexible, Conj.
15	1664405M1	1		5	Tie, Cable	Attache câble	Enlace de Cable
16	339229X1	1	M6 x 40	2	Screw	Vis	Tornillo
17	1462583M1	1		1	Plate	Plaque	Placa
18	6102170M1	1		1	Bracket, Clamp	Bride de fixation	Brida de fijación
19	6102170M1	1		1	Bracket, Clamp	Bride de fixation	Brida de fijación
20	339229X1	1	M6 x 40	2	Screw	Vis	Tornillo
21	1462583M1	1		1	Plate	Plaque	Placa
22	6102788M1	1		1	Bracket, Clamp	Bride de fixation	Brida de fijación
23	6102788M1	1		1	Bracket, Clamp	Bride de fixation	Brida de fijación
24	6109586M91	1		1	Dipperstick Assy	Ensemble de balancier	Balancín, Conj.
25	3510860M91	1		1	Kit, Shim	Jeu de cales	Juego de calces
26	3522720M2	1	45 x 250 mm	1	Pin	Axe	Pasador
27	3518145M91	1		2	Hose Assy	Ensemble de flexible	Flexible, Conj.
28	356612X1	1	7/16" UNF	2	Nut	Écrou	Tuerca
29	6102922M91	1		2	Hose Assy	Ensemble de flexible	Flexible, Conj.

A With Quick Attach
 Avec attache rapide
 Con acoplamiento rápido



860 880 970 980
 TX870B TX970B

811 812 815 816 823 824 843 844 853 854 923 932

98066C01.1

6199042M3

1

Jan-06

Extendahoe Hydraulics Kit
Coffret de Circuit Hydraulique Extendahoe
Juego de circuito hidráulico Extendahoe

Centremount
Montage Pelle Central
Excavadora de montaje central

Control Pedal
 Pédale de Commande
 Pedal de control

4.9m
 4.9m
 4.9m

C-98066-02.1-A

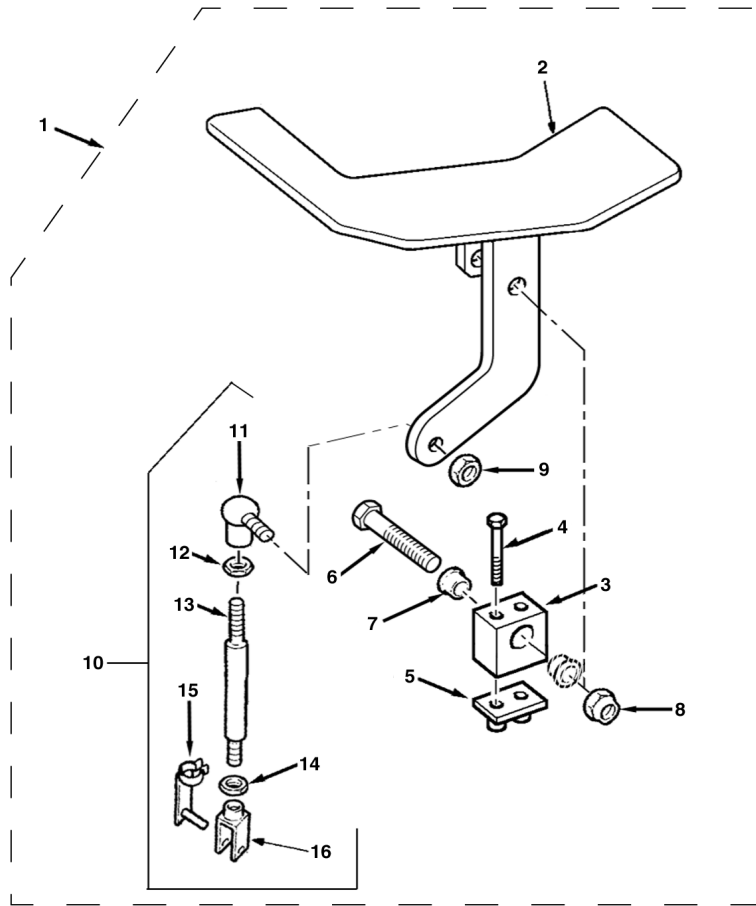

1	6110174M91		(A)Continued	1	Kit, Conversion	Jeu Conversion	Juego de conversion
2	6106874M91	1		1	Pedal Assy	Ensemble de pédale	Pedal, Conj.
3	6106734M1	1		1	Pivot	Pivot	Pivote
4	3001758X1	1	M6 x 50	2	Screw	Vis	Tornillo
5	3519538M1	1		1	Plate, Base	Plaque de base	Placa de base
6	6106981M1	1	M10 x 60	1	Bolt	Boulon	Perno
7	6106866M1	1		1	Bushing	Bague	Anillo
8	1440329X1	1	M10	1	Nut, Lock	Écrou de blocage	Tuerca de retención
9	394367X1	1	M8	1	Nut, Lock	Écrou de blocage	Tuerca de retención
10	6106724M92	1		1	Rod Assy	Ensemble tringlerie	Tirantes, Conj.
11	3517518M1	10		1	Ball Joint	Rotule	Rotula
12	339169X1	10	M8	1	Nut	Écrou	Tuerca
13		10	➡ Ref. 10	1	Rod	Tringle	Vástago
14	3519650M1	10	M8 LH Thread	1	Nut	Écrou	Tuerca
15	3520666M1	10		1	Pin, Clevis	Axe de chape	Eje de brida
16	3519590M1	10	LH Thread	1	Clevis	Chape	Brida
17	6101865M2	1		1	Decal	Adhésif	Adhesivo

A With Quick Attach
 Avec attache rapide
 Con acoplamiento rápido



860 880 970 980
 TX870B TX970B

811 812 815 816 823 824 843 844 853 854 923 932

98066C02.1

6199042M3

1

Jan-06

Extendahoe Hydraulics Kit
Coffret de Circuit Hydraulique Extendahoe
Juego de circuito hidráulico Extendahoe

Centremount
Montage Pelle Central
Excavadora de montaje central

With Auxiliary Hydraulics
 Avec Hydraulique Auxiliaire
 Con hidraulico auxiliar

4.5m
 4.5m
 4.5m

C-98067-01.1-A

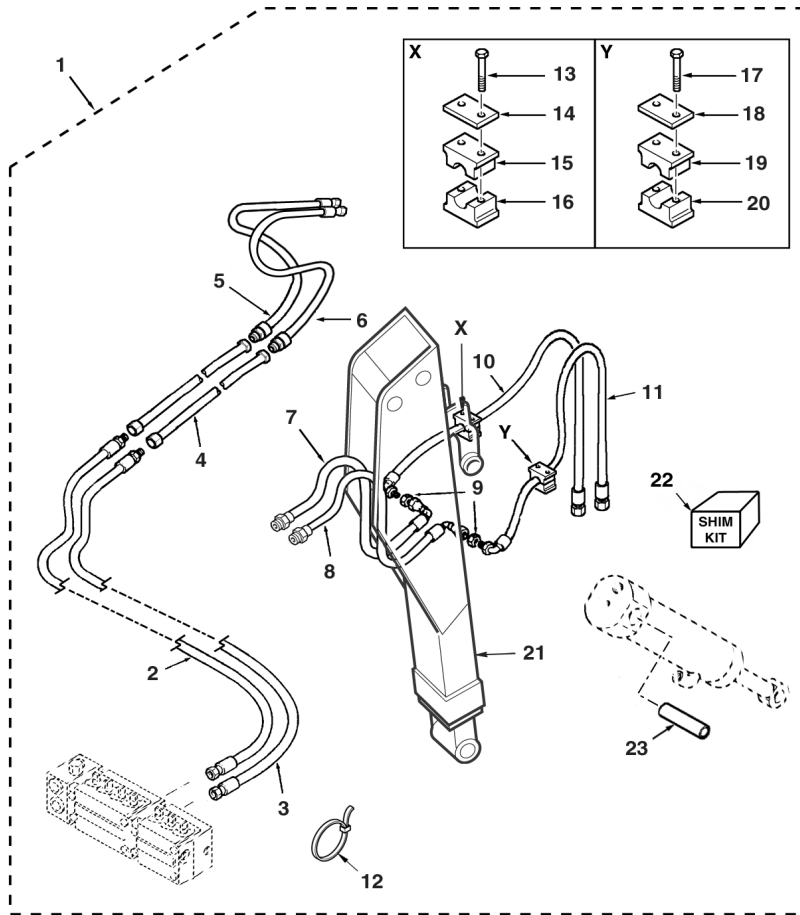

1	6110175M91	(A)	1	Kit, Conversion	Jeu Conversion	Juego de conversion
2	6107464M93	1	1	Hose Assy	Ensemble de flexible	Flexible, Conj.
3	6107465M92	1	1	Hose Assy	Ensemble de flexible	Flexible, Conj.
4	6101773M91	1	2	Tube Assy	Tuyauterie	Conjunto de tubería
5	6101741M91	1	1	Hose Assy	Ensemble de flexible	Flexible, Conj.
6	6101757M91	1	1	Hose Assy	Ensemble de flexible	Flexible, Conj.
7	6101739M91	1	1	Hose Assy	Ensemble de flexible	Flexible, Conj.
8	6101740M91	1	1	Hose Assy	Ensemble de flexible	Flexible, Conj.
9	355574X1	1	2	Nut	Écrou	Tuerca
10	6101007M91	1	1	Hose Assy	Ensemble de flexible	Flexible, Conj.
11	6101008M91	1	1	Hose Assy	Ensemble de flexible	Flexible, Conj.
12	1664405M1	1	2	Tie, Cable	Attache câble	Enlace de Cable
13	339229X1	1	2	Screw	Vis	Tornillo
14	1462583M1	1	1	Plate	Plaque	Placa
15	6102170M1	1	1	Bracket, Clamp	Bride de fixation	Brida de fijación
16	6102170M1	1	1	Bracket, Clamp	Bride de fixation	Brida de fijación
17	339229X1	1	2	Screw	Vis	Tornillo
18	1462583M1	1	1	Plate	Plaque	Placa
19	6102788M1	1	1	Bracket, Clamp	Bride de fixation	Brida de fijación
20	6102788M1	1	1	Bracket, Clamp	Bride de fixation	Brida de fijación
21	6109586M91	1	1	Dipperstick Assy	Ensemble de balancier	Balancín, Conj.
22	3510860M91	1	1	Kit, Shim	Jeu de cales	Juego de calces
23	3522720M2	1	1	Pin	Axe	Pasador

A Without Quick Attach
 Sans attache rapide
 Sin acoplamiento rápido



820 860 880 970
 TX760B TX860B

801 802 803 804 809 810 813 814 821 822 831 832 841 842 851 852 922

98067C01.1

6199042M3

1

Jan-06

Extendahoe Hydraulics Kit
Coffret de Circuit Hydraulique Extendahoe
Juego de circuito hidráulico Extendahoe

Centremount
Montage Pelle Central
Excavadora de montaje central

Control Pedal
 Pédale de Commande
 Pedal de control

4.5m
 4.5m
 4.5m

C-98067-02.1-A

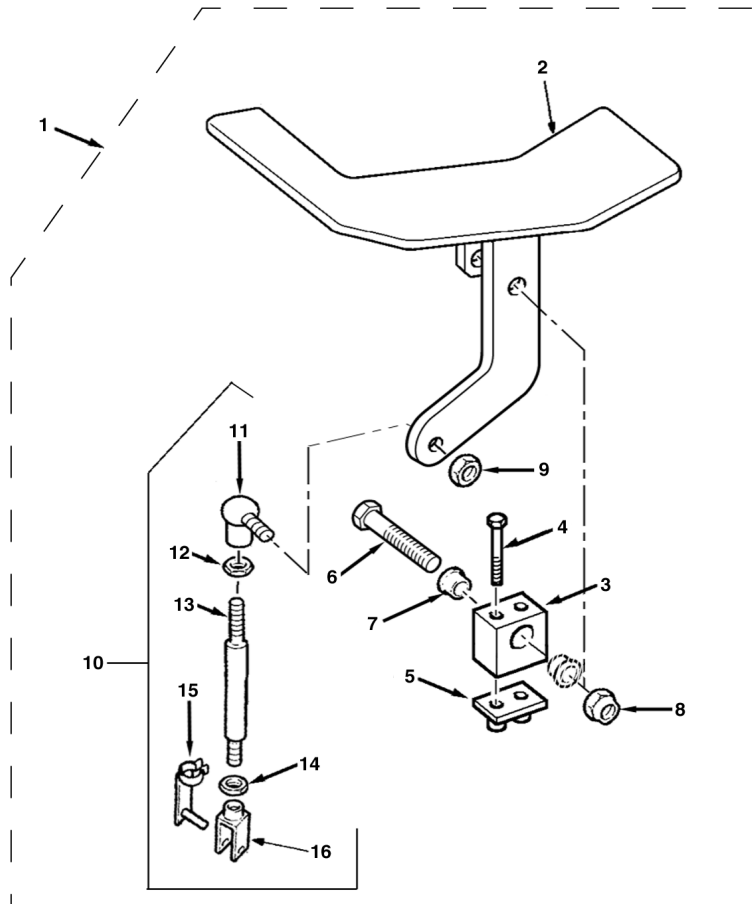

1	6110175M91		(A)Continued	1	Kit, Conversion	Jeu Conversion	Juego de conversion
2	6106874M91	1		1	Pedal Assy	Ensemble de pédale	Pedal, Conj.
3	6106734M1	1		1	Pivot	Pivot	Pivote
4	3001758X1	1	M6 x 50	2	Screw	Vis	Tornillo
5	3519538M1	1		1	Plate, Base	Plaque de base	Placa de base
6	6106981M1	1	M10 x 60	1	Bolt	Boulon	Perno
7	6106866M1	1		1	Bushing	Bague	Anillo
8	1440329X1	1	M10	1	Nut, Lock	Écrou de blocage	Tuerca de retención
9	394367X1	1	M8	1	Nut, Lock	Écrou de blocage	Tuerca de retención
10	6106724M92	1		1	Rod Assy	Ensemble tringlerie	Tirantes, Conj.
11	3517518M1	10		1	Ball Joint	Rotule	Rotula
12	339169X1	10	M8	1	Nut	Écrou	Tuerca
13		10	➔ Ref. 10	1	Rod	Tringle	Vástago
14	3519650M1	10	LH Thread M8 LH Thread	1	Nut	Écrou	Tuerca
15	3520666M1	10		1	Pin, Clevis	Axe de chape	Eje de brida
16	3519590M1	10	LH Thread LH Thread	1	Clevis	Chape	Brida
17	6101865M2	1		1	Decal	Adhésif	Adhesivo

A Without Quick Attach
 Sans attache rapide
 Sin acoplamiento rápido



820 860 880 970
 TX760B TX860B

801 802 803 804 809 810 813 814 821 822 831 832 841 842 851 852 922

98067C02.1

6199042M3

1

Jan-06

Extendahoe Hydraulics Kit
Coffret de Circuit Hydraulique Extendahoe
Juego de circuito hidráulico Extendahoe

Centremount
Montage Pelle Central
Excavadora de montaje central

With Auxiliary Hydraulics
 Avec Hydraulique Auxiliaire
 Con hidráulico auxiliar

4.5m
 4.5m
 4.5m

C-98068-01.1-A

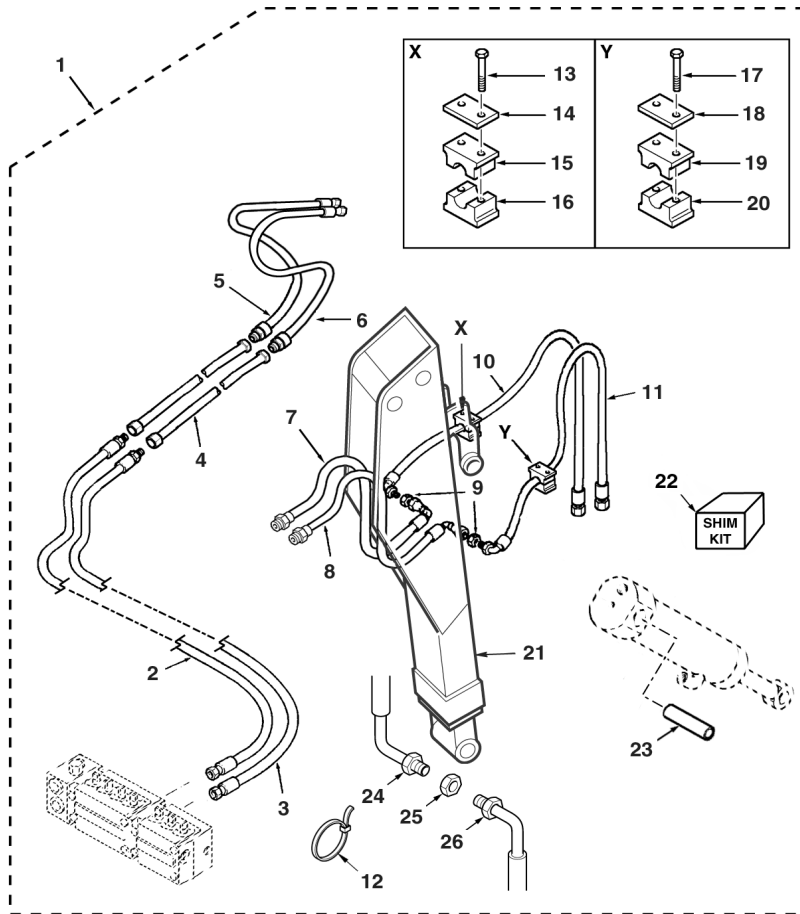

1	6110176M91		(A)	1	Kit, Conversion	Jeu Conversion	Juego de conversion
2	6107464M93	1		1	Hose Assy	Ensemble de flexible	Flexible, Conj.
3	6107465M92	1		1	Hose Assy	Ensemble de flexible	Flexible, Conj.
4	6101773M91	1		2	Tube Assy	Tuyauterie	Conjunto de tubería
5	6101741M91	1	Dark Green	1	Hose Assy	Ensemble de flexible	Flexible, Conj.
6	6101757M91	1	Black	1	Hose Assy	Ensemble de flexible	Flexible, Conj.
7	6101739M91	1	Brown	1	Hose Assy	Ensemble de flexible	Flexible, Conj.
8	6101740M91	1	White	1	Hose Assy	Ensemble de flexible	Flexible, Conj.
9	355574X1	1		2	Nut	Écrou	Tuerca
10	6101007M91	1	Brown	1	Hose Assy	Ensemble de flexible	Flexible, Conj.
11	6101008M91	1	White	1	Hose Assy	Ensemble de flexible	Flexible, Conj.
12	1664405M1	1		5	Tie, Cable	Attache câble	Enlace de Cable
13	339229X1	1	M6 x 40	2	Screw	Vis	Tornillo
14	1462583M1	1		1	Plate	Plaque	Placa
15	6102170M1	1		1	Bracket, Clamp	Bride de fixation	Brida de fijación
16	6102170M1	1		1	Bracket, Clamp	Bride de fixation	Brida de fijación
17	339229X1	1	M6 x 40	2	Screw	Vis	Tornillo
18	1462583M1	1		1	Plate	Plaque	Placa
19	6102788M1	1		1	Bracket, Clamp	Bride de fixation	Brida de fijación
20	6102788M1	1		1	Bracket, Clamp	Bride de fixation	Brida de fijación
21	6109586M91	1		1	Dipperstick Assy	Ensemble de balancier	Balancín, Conj.
22	3510860M91	1		1	Kit, Shim	Jeu de cales	Juego de calces
23	3522720M2	1	45 x 250 mm	1	Pin	Axe	Pasador
24	3521945M95	1		2	Hose Assy	Ensemble de flexible	Flexible, Conj.
25	356612X1	1	7/16" UNF	2	Nut	Écrou	Tuerca
26	6102922M91	1		2	Hose Assy	Ensemble de flexible	Flexible, Conj.

A With Quick Attach
 Avec attache rapide
 Con acoplamiento rápido



820 860 880 970
 TX760B TX860B

801 802 803 804 809 810 813 814 821 822 831 832 841 842 851 852 922

98068C01.1

6199042M3

1

Jan-06

Extendahoe Hydraulics Kit
Coffret de Circuit Hydraulique Extendahoe
Juego de circuito hidráulico Extendahoe

Centremount
Montage Pelle Central
Excavadora de montaje central

Control Pedal
 Pédale de Commande
 Pedal de control

4.5m
 4.5m
 4.5m

C-98068-02.1-A

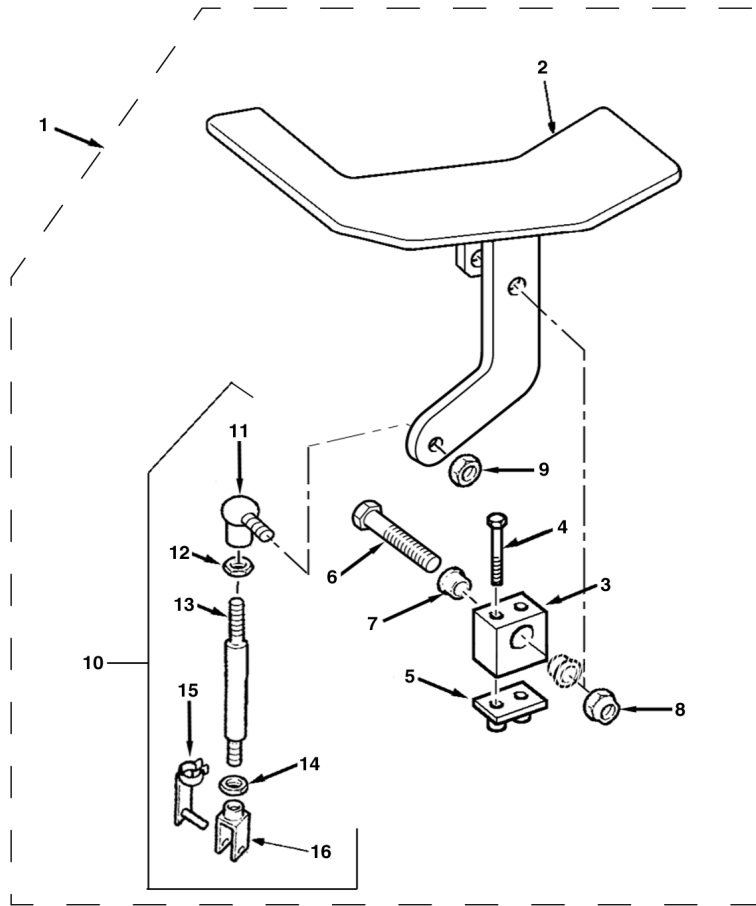

1	6110176M91		(A)Continued	1	Kit, Conversion	Jeu Conversion	Juego de conversión
2	6106874M91	1		1	Pedal Assy	Ensemble de pédale	Pedal, Conj.
3	6106734M1	1		1	Pivot	Pivot	Pivote
4	3001758X1	1	M6 x 50	2	Screw	Vis	Tornillo
5	3519538M1	1		1	Plate, Base	Plaque de base	Placa de base
6	6106981M1	1	M10 x 60	1	Bolt	Boulon	Perno
7	6106866M1	1		1	Bushing	Bague	Anillo
8	1440329X1	1	M10	1	Nut, Lock	Écrou de blocage	Tuerca de retención
9	394367X1	1	M8	1	Nut, Lock	Écrou de blocage	Tuerca de retención
10	6106724M92	1		1	Rod Assy	Ensemble tringlerie	Tirantes, Conj.
11	3517518M1	10		1	Ball Joint	Rotule	Rotula
12	339169X1	10	M8	1	Nut	Écrou	Tuerca
13		10	➔ Ref. 10	1	Rod	Tringle	Vástago
14	3519650M1	10	M8 LH Thread	1	Nut	Écrou	Tuerca
15	3520666M1	10		1	Pin, Clevis	Axe de chape	Eje de brida
16	3519590M1	10	LH Thread	1	Clevis	Chape	Brida
17	6101865M2	1		1	Decal	Adhésif	Adhesivo

A With Quick Attach
 Avec attache rapide
 Con acoplamiento rápido



820 860 880 970
 TX760B TX860B

801 802 803 804 809 810 813 814 821 822 831 832 841 842 851 852 922

98068C02.1

6199042M3

1

Jan-06

Extendahoe Hydraulics Kit
Coffret de Circuit Hydraulique Extendahoe
Juego de circuito hidráulico Extendahoe

Centremount
Montage Pelle Central
Excavadora de montaje central

With Auxiliary Hydraulics
 Avec Hydraulique Auxiliaire
 Con hidráulico auxiliar

4.9m
 4.9m
 4.9m

C-98069-01.1-A

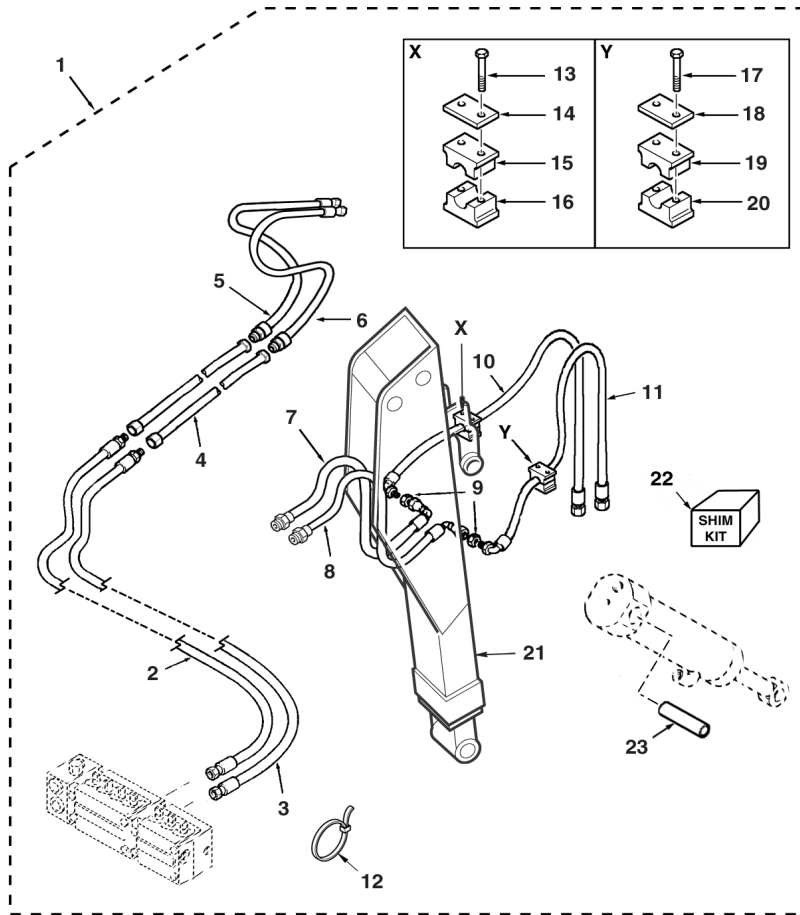

1	6110177M91	(A)	1	Kit, Conversion	Jeu Conversion	Juego de conversion
2	6107464M93	1	1	Hose Assy	Ensemble de flexible	Flexible, Conj.
3	6107465M92	1	1	Hose Assy	Ensemble de flexible	Flexible, Conj.
4	6101734M91	1	2	Tube Assy	Tuyauterie	Conjunto de tubería
5	6101741M91	1	1	Hose Assy	Ensemble de flexible	Flexible, Conj.
6	6101757M91	1	1	Hose Assy	Ensemble de flexible	Flexible, Conj.
7	6101739M91	1	1	Hose Assy	Ensemble de flexible	Flexible, Conj.
8	6101740M91	1	1	Hose Assy	Ensemble de flexible	Flexible, Conj.
9	355574X1	1	2	Nut	Écrou	Tuerca
10	6101007M91	1	1	Hose Assy	Ensemble de flexible	Flexible, Conj.
11	6101008M91	1	1	Hose Assy	Ensemble de flexible	Flexible, Conj.
12	1664405M1	1	2	Tie, Cable	Attache câble	Enlace de Cable
13	339229X1	1	2	Screw	Vis	Tornillo
14	1462583M1	1	1	Plate	Plaque	Placa
15	6102170M1	1	1	Bracket, Clamp	Bride de fixation	Brida de fijación
16	6102170M1	1	1	Bracket, Clamp	Bride de fixation	Brida de fijación
17	339229X1	1	2	Screw	Vis	Tornillo
18	1462583M1	1	1	Plate	Plaque	Placa
19	6102788M1	1	1	Bracket, Clamp	Bride de fixation	Brida de fijación
20	6102788M1	1	1	Bracket, Clamp	Bride de fixation	Brida de fijación
21	6109586M91	1	1	Dipperstick Assy	Ensemble de balancier	Balancín, Conj.
22	3510860M91	1	1	Kit, Shim	Jeu de cales	Juego de calces
23	3522720M2	1	1	Pin	Axe	Pasador

A Without Quick Attach
 Sans attache rapide
 Sin acoplamiento rápido



860 880 970 980
 TX870B TX970B

811 812 815 816 823 824 843 844 853 854 923 932

98069C01.1

6199042M3

1

Jan-06

Extendahoe Hydraulics Kit
Coffret de Circuit Hydraulique Extendahoe
Juego de circuito hidráulico Extendahoe

Centremount
Montage Pelle Central
Excavadora de montaje central

Control Pedal
 Pédale de Commande
 Pedal de control

4.9m
 4.9m
 4.9m

C-98069-02.1-A

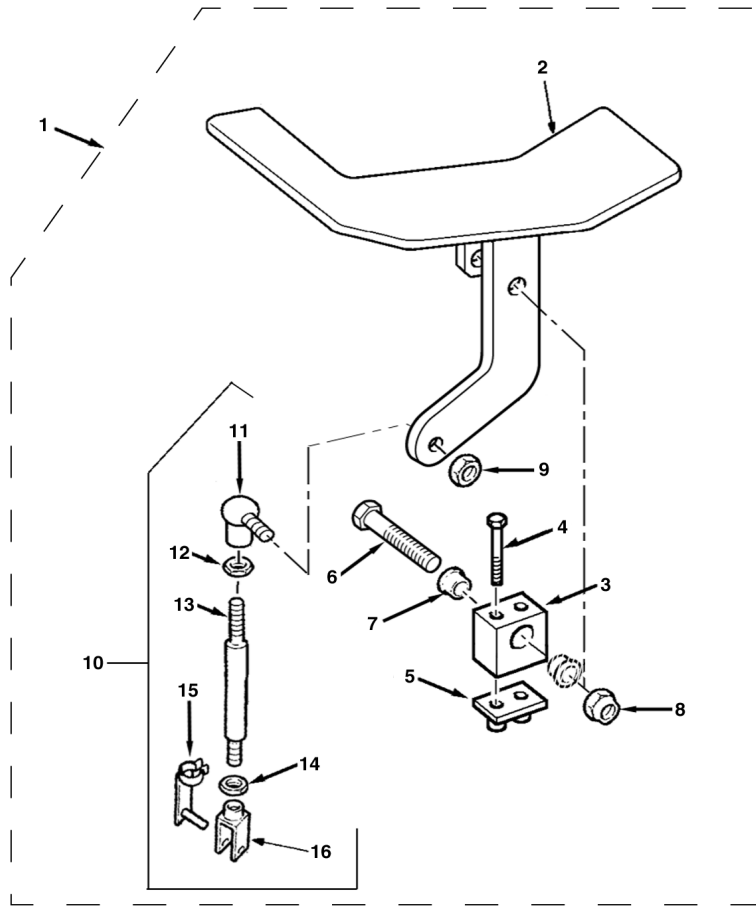

1	6110177M91		(A)Continued	1	Kit, Conversion	Jeu Conversion	Juego de conversion
2	6106874M91	1		1	Pedal Assy	Ensemble de pédale	Pedal, Conj.
3	6106734M1	1		1	Pivot	Pivot	Pivote
4	3001758X1	1	M6 x 50	2	Screw	Vis	Tornillo
5	3519538M1	1		1	Plate, Base	Plaque de base	Placa de base
6	6106981M1	1	M10 x 60	1	Bolt	Boulon	Perno
7	6106866M1	1		1	Bushing	Bague	Anillo
8	1440329X1	1	M10	1	Nut, Lock	Écrou de blocage	Tuerca de retención
9	394367X1	1	M8	1	Nut, Lock	Écrou de blocage	Tuerca de retención
10	6106724M92	1		1	Rod Assy	Ensemble tringlerie	Tirantes, Conj.
11	3517518M1	10		1	Ball Joint	Rotule	Rotula
12	339169X1	10	M8	1	Nut	Écrou	Tuerca
13		10	➔ Ref. 10	1	Rod	Tringle	Vástago
14	3519650M1	10	M8 LH Thread	1	Nut	Écrou	Tuerca
15	3520666M1	10		1	Pin, Clevis	Axe de chape	Eje de brida
16	3519590M1	10	LH Thread	1	Clevis	Chape	Brida
17	6101865M2	1		1	Decal	Adhésif	Adhesivo

A Without Quick Attach
 Sans attache rapide
 Sin acoplamiento rápido



860 880 970 980
 TX870B TX970B

811 812 815 816 823 824 843 844 853 854 923 932

98069C02.1

6199042M3

1

Jan-06

Extendahoe Hydraulics Kit
Coffret de Circuit Hydraulique Extendahoe
Juego de circuito hidráulico Extendahoe

Centremount
Montage Pelle Central
Excavadora de montaje central

With Auxiliary Hydraulics
 Avec Hydraulique Auxiliaire
 Con hidráulico auxiliar

4.9m
 4.9m
 4.9m

C-98070-01.1-A

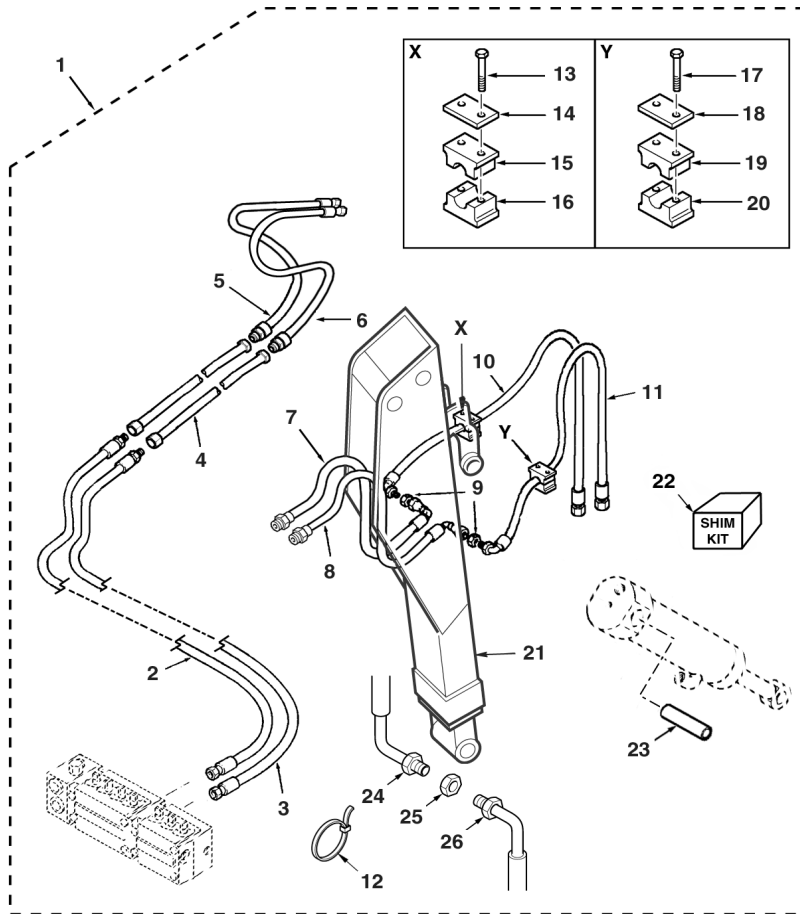

1	6110178M91	(A)	1	Kit, Conversion	Jeu Conversion	Juego de conversion
2	6107464M93	1	1	Hose Assy	Ensemble de flexible	Flexible, Conj.
3	6107465M92	1	1	Hose Assy	Ensemble de flexible	Flexible, Conj.
4	6101734M91	1	2	Tube Assy	Tuyauterie	Conjunto de tubería
5	6101741M91	1	1	Hose Assy	Ensemble de flexible	Flexible, Conj.
6	6101757M91	1	1	Hose Assy	Ensemble de flexible	Flexible, Conj.
7	6101739M91	1	1	Hose Assy	Ensemble de flexible	Flexible, Conj.
8	6101740M91	1	1	Hose Assy	Ensemble de flexible	Flexible, Conj.
9	355574X1	1	2	Nut	Écrou	Tuerca
10	6101007M91	1	1	Hose Assy	Ensemble de flexible	Flexible, Conj.
11	6101008M91	1	1	Hose Assy	Ensemble de flexible	Flexible, Conj.
12	1664405M1	1	5	Tie, Cable	Attache câble	Enlace de Cable
13	339229X1	1	2	Screw	Vis	Tornillo
14	1462583M1	1	1	Plate	Plaque	Placa
15	6102170M1	1	1	Bracket, Clamp	Bride de fixation	Brida de fijación
16	6102170M1	1	1	Bracket, Clamp	Bride de fixation	Brida de fijación
17	339229X1	1	2	Screw	Vis	Tornillo
18	1462583M1	1	1	Plate	Plaque	Placa
19	6102788M1	1	1	Bracket, Clamp	Bride de fixation	Brida de fijación
20	6102788M1	1	1	Bracket, Clamp	Bride de fixation	Brida de fijación
21	6109586M91	1	1	Dipperstick Assy	Ensemble de balancier	Balancín, Conj.
22	3510860M91	1	1	Kit, Shim	Jeu de cales	Juego de calces
23	3522720M2	1	1	Pin	Axe	Pasador
24	3518145M91	1	2	Hose Assy	Ensemble de flexible	Flexible, Conj.
25	356612X1	1	2	Nut	Écrou	Tuerca
26	6102922M91	1	2	Hose Assy	Ensemble de flexible	Flexible, Conj.

A With Quick Attach
 Avec attache rapide
 Con acoplamiento rápido



860 880 970 980
 TX870B TX970B

811 812 815 816 823 824 843 844 853 854 923 932

98070C01.1

6199042M3

1

Jan-06

Extendahoe Hydraulics Kit
Coffret de Circuit Hydraulique Extendahoe
Juego de circuito hidráulico Extendahoe

Centremount
Montage Pelle Central
Excavadora de montaje central

Control Pedal
 Pédale de Commande
 Pedal de control

4.9m
 4.9m
 4.9m

C-98070-02.1-A

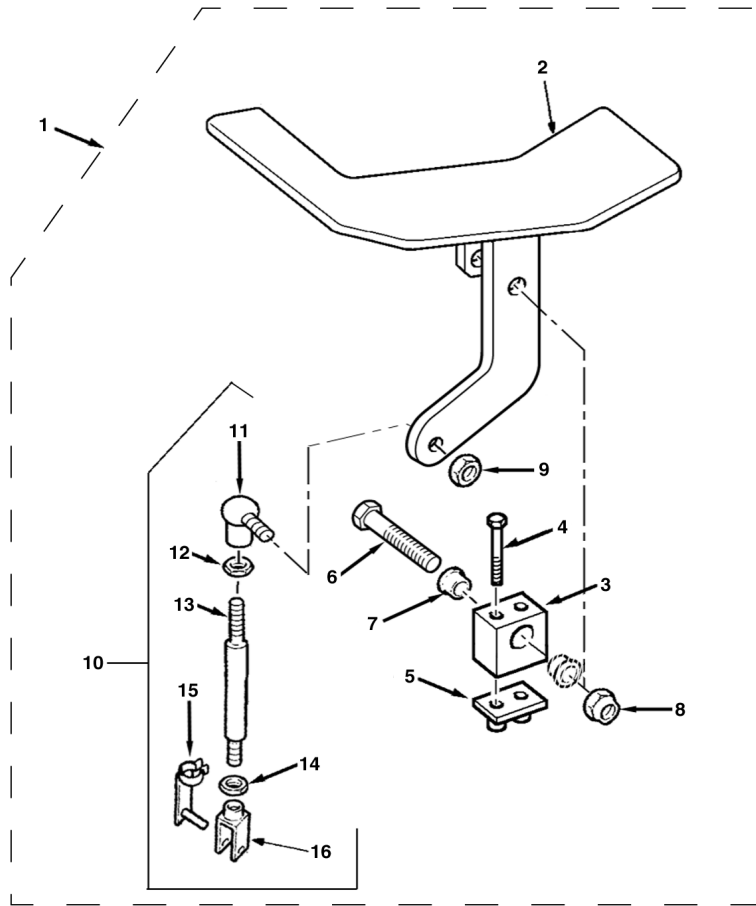

1	6110178M91		(A)Continued	1	Kit, Conversion	Jeu Conversion	Juego de conversion
2	6106874M91	1		1	Pedal Assy	Ensemble de pédale	Pedal, Conj.
3	6106734M1	1		1	Pivot	Pivot	Pivote
4	3001758X1	1	M6 x 50	2	Screw	Vis	Tornillo
5	3519538M1	1		1	Plate, Base	Plaque de base	Placa de base
6	6106981M1	1	M10 x 60	1	Bolt	Boulon	Perno
7	6106866M1	1		1	Bushing	Bague	Anillo
8	1440329X1	1	M10	1	Nut, Lock	Écrou de blocage	Tuerca de retención
9	394367X1	1	M8	1	Nut, Lock	Écrou de blocage	Tuerca de retención
10	6106724M92	1		1	Rod Assy	Ensemble tringlerie	Tirantes, Conj.
11	3517518M1	10		1	Ball Joint	Rotule	Rotula
12	339169X1	10	M8	1	Nut	Écrou	Tuerca
13		10	➔ Ref. 10	1	Rod	Tringle	Vástago
14	3519650M1	10	M8 LH Thread	1	Nut	Écrou	Tuerca
15	3520666M1	10		1	Pin, Clevis	Axe de chape	Eje de brida
16	3519590M1	10	LH Thread	1	Clevis	Chape	Brida
17	6101865M2	1		1	Decal	Adhésif	Adhesivo

A With Quick Attach
 Avec attache rapide
 Con acoplamiento rápido



860 880 970 980
 TX870B TX970B

811 812 815 816 823 824 843 844 853 854 923 932

98070C02.1

6199042M3

1

Jan-06

Extendahoe Hydraulics Kit
Coffret de Circuit Hydraulique Extendahoe
Juego de circuito hidráulico Extendahoe

Sideshift
Montage de Pelle Latéral
Excavadora montaje horizontal

Without Auxiliary Hydraulics
 Sans Hydraulique Auxiliaire
 Sin hidraulico auxiliar

C-98059-01.1-A

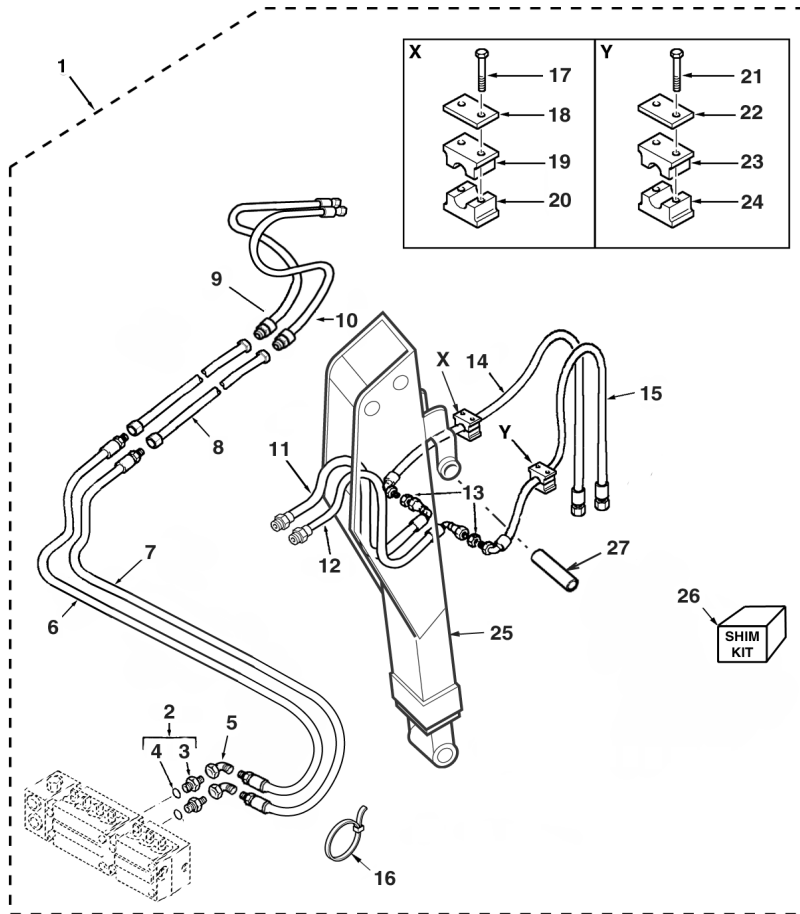

1	6110167M91		(A)	1	Kit, Conversion	Jeu Conversion	Juego de conversion
2	3517847M91	1		2	Union	Union	Unión
3		2	Ref. 2	1	Union	Union	Unión
4	835024M1	2		1	O-Ring	Joint torique	Junta de tipo O
5	367386X1	1		2	Elbow, 90°	Coude à 90°	Codo, 90°
6	6108764M91	1		1	Hose Assy	Ensemble de flexible	Flexible, Conj.
7	6108765M91	1		1	Hose Assy	Ensemble de flexible	Flexible, Conj.
8	6101773M91	1		2	Tube Assy	Tuyauterie	Conjunto de tubería
9	6101741M91	1	Dark Green	1	Hose Assy	Ensemble de flexible	Flexible, Conj.
10	6101757M91	1	Black	1	Hose Assy	Ensemble de flexible	Flexible, Conj.
11	6101739M91	1	Brown	1	Hose Assy	Ensemble de flexible	Flexible, Conj.
12	6101740M91	1	White	1	Hose Assy	Ensemble de flexible	Flexible, Conj.
13	355574X1	1		2	Nut	Écrou	Tuerca
14	6101007M91	1	Brown	1	Hose Assy	Ensemble de flexible	Flexible, Conj.
15	6101008M91	1	White	1	Hose Assy	Ensemble de flexible	Flexible, Conj.
16	1664405M1	1		2	Tie, Cable	Attache câble	Enlace de Cable
17	339229X1	1	M6 x 40	2	Screw	Vis	Tornillo
18	1462583M1	1		1	Plate	Plaque	Placa
19	6102788M1	1		1	Bracket, Clamp	Bride de fixation	Brida de fijación
20	6102788M1	1		1	Bracket, Clamp	Bride de fixation	Brida de fijación
21	339229X1	1	M6 x 40	2	Screw	Vis	Tornillo
22	1462583M1	1		1	Plate	Plaque	Placa
23	6102170M1	1		1	Bracket, Clamp	Bride de fixation	Brida de fijación
24	6102170M1	1		1	Bracket, Clamp	Bride de fixation	Brida de fijación
25	6109586M91	1		1	Dipperstick Assy	Ensemble de balancier	Balancier, Conj.
26	3510860M91	1		1	Kit, Shim	Jeu de cales	Juego de calces
27	3522720M2	1	45 x 250 mm	1	Pin	Axe	Pasador

A Without Quick Attach
 Sans attache rapide
 Sin acoplamiento rápido



820 860 880 970 980
 TX760B TX860B

805 806 807 808 817 825 833 834 845 855 921 931

98059C01.1

6199042M3

1

Jan-06

Extendahoe Hydraulics Kit
Coffret de Circuit Hydraulique Extendahoe
Juego de circuito hidráulico Extendahoe

Sideshift
Montage de Pelle Latéral
Excavadora montaje horizontal

Control Pedal
Pédale de Commande
Pedal de control

C-98059-02.1-A

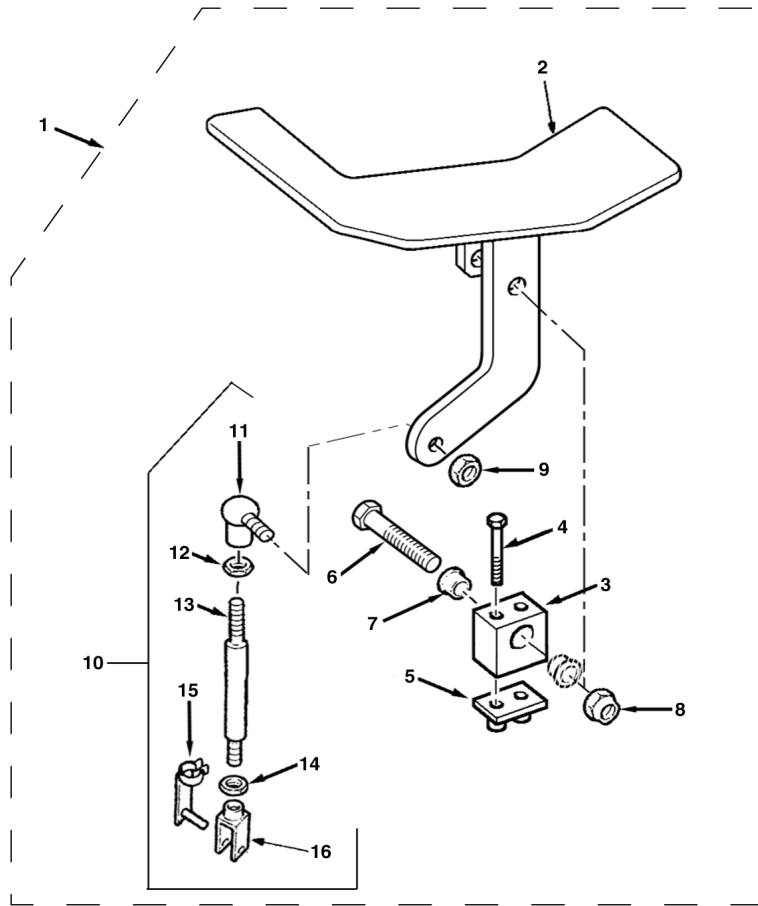

1	6110167M91		(A)Continued	1	Kit, Conversion	Jeu Conversion	Juego de conversion
2	6106874M91	1		1	Pedal Assy	Ensemble de pédale	Pedal, Conj.
3	6106734M1	1		1	Pivot	Pivot	Pivote
4	3001758X1	1	M6 x 50	2	Screw	Vis	Tornillo
5	3519538M1	1		1	Plate, Base	Plaque de base	Placa de base
6	6106981M1	1	M10 x 60	1	Bolt	Boulon	Perno
7	6106866M1	1		1	Bushing	Bague	Anillo
8	1440329X1	1	M10	1	Nut, Lock	Écrou de blocage	Tuerca de retención
9	394367X1	1	M8	1	Nut, Lock	Écrou de blocage	Tuerca de retención
10	6106724M92	1		1	Rod Assy	Ensemble tringlerie	Tirantes, Conj.
11	3517518M1	10		1	Ball Joint	Rotule	Rotula
12	339169X1	10	M8	1	Nut	Écrou	Tuerca
13		10	➔ Ref. 10	1	Rod	Tringle	Vástago
14	3519650M1	10	M8 LH Thread	1	Nut	Écrou	Tuerca
15	3520666M1	10		1	Pin, Clevis	Axe de chape	Eje de brida
16	3519590M1	10	LH Thread	1	Clevis	Chape	Brida
17	6101865M2	1		1	Decal	Adhésif	Adhesivo

A Without Quick Attach
 Sans attache rapide
 Sin acoplamiento rápido



820 860 880 970 980
 TX760B TX860B

805 806 807 808 817 825 833 834 845 855 921 931

98059C02.1

6199042M3

1

Jan-06

Extendahoe Hydraulics Kit
Coffret de Circuit Hydraulique Extendahoe
Juego de circuito hidráulico Extendahoe

Sideshift
Montage de Pelle Latéral
Excavadora montaje horizontal

Without Auxiliary Hydraulics
Sans Hydraulique Auxiliaire
Sin hidraulico auxiliar

C-98060-01.1-A

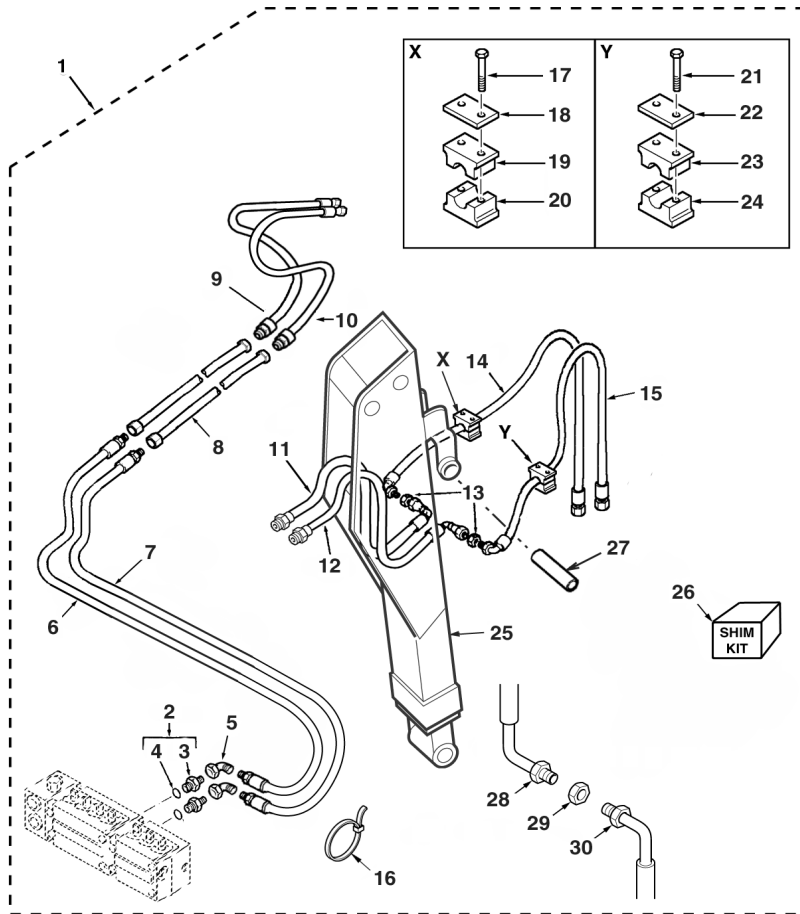

1	6110168M91		(A)	1	Kit, Conversion	Jeu Conversion	Juego de conversion
2	3517847M91	1		2	Union	Union	Unión
3		2	➤ Ref. 2	1	Union	Union	Unión
4	835024M1	2		1	O-Ring	Joint torique	Junta de tipo O
5	367386X1	1		2	Elbow, 90°	Coude à 90°	Codo, 90°
6	6108764M91	1		1	Hose Assy	Ensemble de flexible	Flexible, Conj.
7	6108765M91	1		1	Hose Assy	Ensemble de flexible	Flexible, Conj.
8	6101773M91	1		2	Tube Assy	Tuyauterie	Conjunto de tubería
9	6101741M91	1	Dark Green	1	Hose Assy	Ensemble de flexible	Flexible, Conj.
10	6101757M91	1	Black	1	Hose Assy	Ensemble de flexible	Flexible, Conj.
11	6101739M91	1	Brown	1	Hose Assy	Ensemble de flexible	Flexible, Conj.
12	6101740M91	1	White	1	Hose Assy	Ensemble de flexible	Flexible, Conj.
13	355574X1	1		2	Nut	Écrou	Tuerca
14	6101007M91	1	Brown	1	Hose Assy	Ensemble de flexible	Flexible, Conj.
15	6101008M91	1	White	1	Hose Assy	Ensemble de flexible	Flexible, Conj.
16	1664405M1	1		5	Tie, Cable	Attache câble	Enlace de Cable
17	339229X1	1	M6 x 40	2	Screw	Vis	Tornillo
18	1462583M1	1		1	Plate	Plaque	Placa
19	6102788M1	1		1	Bracket, Clamp	Bride de fixation	Brida de fijación
20	6102788M1	1		1	Bracket, Clamp	Bride de fixation	Brida de fijación
21	339229X1	1	M6 x 40	2	Screw	Vis	Tornillo
22	1462583M1	1		1	Plate	Plaque	Placa
23	6102170M1	1		1	Bracket, Clamp	Bride de fixation	Brida de fijación
24	6102170M1	1		1	Bracket, Clamp	Bride de fixation	Brida de fijación
25	6109586M91	1		1	Dipperstick Assy	Ensemble de balancier	Balancier, Conj.
26	3510860M91	1		1	Kit, Shim	Jeu de cales	Juego de calces
27	3522720M2	1	45 x 250 mm	1	Pin	Axe	Pasador
28	3521945M95	1		2	Hose Assy	Ensemble de flexible	Flexible, Conj.
29	356612X1	1	7/16" UNF	2	Nut	Écrou	Tuerca
30	6102922M91	1		2	Hose Assy	Ensemble de flexible	Flexible, Conj.

A With Quick Attach
 Avec attache rapide
 Con acoplamiento rápido



820 860 880 970 980
 TX760B TX860B

805 806 807 808 817 825 833 834 845 855 921 931

98060C01.1

6199042M3

1

Jan-06

Extendahoe Hydraulics Kit
Coffret de Circuit Hydraulique Extendahoe
Juego de circuito hidráulico Extendahoe

Sideshift
Montage de Pelle Latéral
Excavadora montaje horizontal

Control Pedal
Pédale de Commande
Pedal de control

C-98060-02.1-A

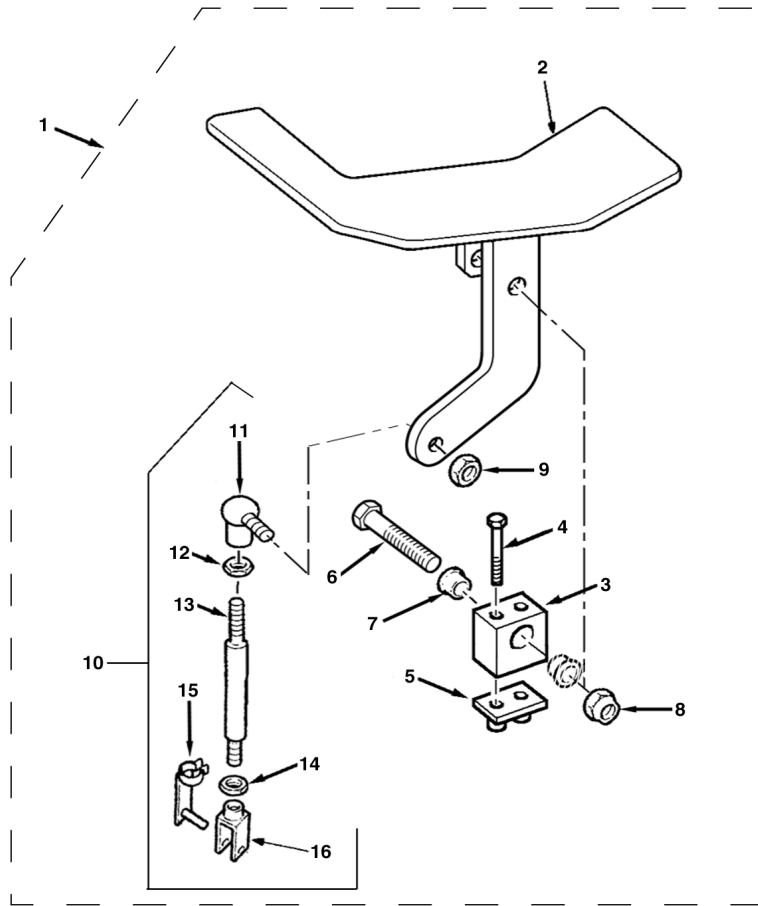

1	6110168M91		(A)Continued	1	Kit, Conversion	Jeu Conversion	Juego de conversion
2	6106874M91	1		1	Pedal Assy	Ensemble de pédale	Pedal, Conj.
3	6106734M1	1		1	Pivot	Pivot	Pivote
4	3001758X1	1	M6 x 50	2	Screw	Vis	Tornillo
5	3519538M1	1		1	Plate, Base	Plaque de base	Placa de base
6	6106981M1	1	M10 x 60	1	Bolt	Boulon	Perno
7	6106866M1	1		1	Bushing	Bague	Anillo
8	1440329X1	1	M10	1	Nut, Lock	Écrou de blocage	Tuerca de retención
9	394367X1	1	M8	1	Nut, Lock	Écrou de blocage	Tuerca de retención
10	6106724M92	1		1	Rod Assy	Ensemble tringlerie	Tirantes, Conj.
11	3517518M1	10		1	Ball Joint	Rotule	Rotula
12	339169X1	10	M8	1	Nut	Écrou	Tuerca
13		10	➔ Ref. 10	1	Rod	Tringle	Vástago
14	3519650M1	10	M8 LH Thread	1	Nut	Écrou	Tuerca
15	3520666M1	10		1	Pin, Clevis	Axe de chape	Eje de brida
16	3519590M1	10	LH Thread	1	Clevis	Chape	Brida
17	6101865M2	1		1	Decal	Adhésif	Adhesivo

A With Quick Attach
 Avec attache rapide
 Con acoplamiento rápido



820 860 880 970 980
 TX760B TX860B

805 806 807 808 817 825 833 834 845 855 921 931

98060C02.1

6199042M3

1

Jan-06

Extendahoe Hydraulics Kit
Coffret de Circuit Hydraulique Extendahoe
Juego de circuito hidráulico Extendahoe

Sideshift
Montage de Pelle Latéral
Excavadora montaje horizontal

With Auxiliary Hydraulics
 Avec Hydraulique Auxiliaire
 Con hidraulico auxiliar

C-98061-01.1-A

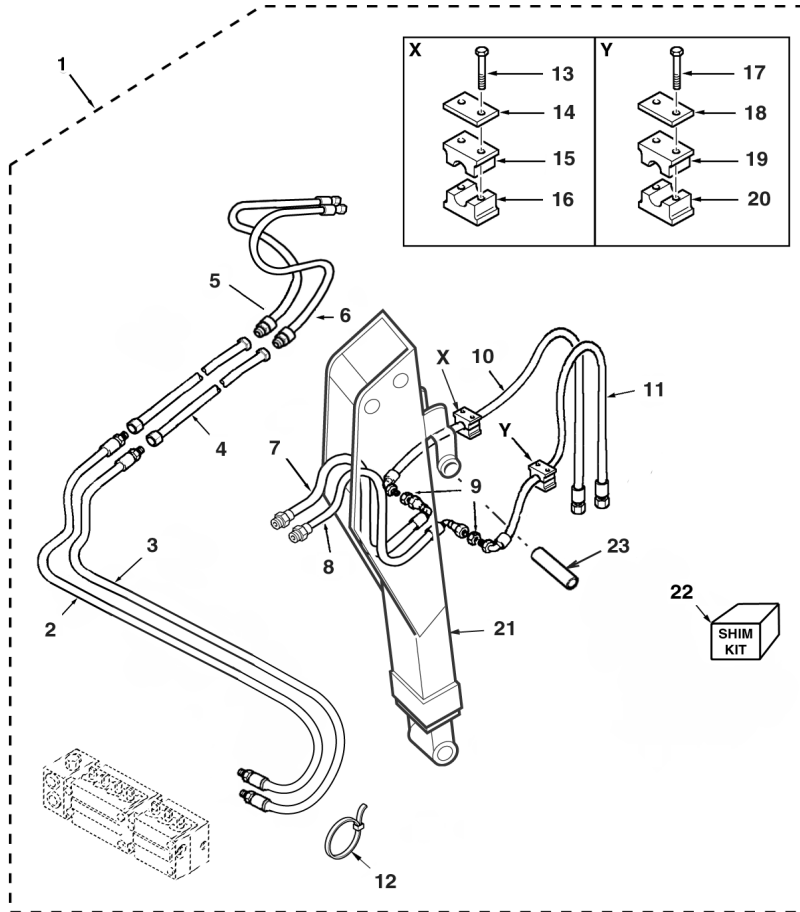

1	6110169M91	(A)	1	Kit, Conversion	Jeu Conversion	Juego de conversion
2	6108764M91	1	1	Hose Assy	Ensemble de flexible	Flexible, Conj.
3	6108765M91	1	1	Hose Assy	Ensemble de flexible	Flexible, Conj.
4	6101773M91	1	2	Tube Assy	Tuyauterie	Conjunto de tubería
5	6101741M91	1	1	Hose Assy	Ensemble de flexible	Flexible, Conj.
6	6101757M91	1	1	Hose Assy	Ensemble de flexible	Flexible, Conj.
7	6101739M91	1	1	Hose Assy	Ensemble de flexible	Flexible, Conj.
8	6101740M91	1	1	Hose Assy	Ensemble de flexible	Flexible, Conj.
9	355574X1	1	2	Nut	Écrou	Tuerca
10	6101007M91	1	1	Hose Assy	Ensemble de flexible	Flexible, Conj.
11	6101008M91	1	1	Hose Assy	Ensemble de flexible	Flexible, Conj.
12	1664405M1	1	2	Tie, Cable	Attache câble	Enlace de Cable
13	339229X1	1	2	Screw	Vis	Tornillo
14	1462583M1	1	1	Plate	Plaque	Placa
15	6102788M1	1	1	Bracket, Clamp	Bride de fixation	Brida de fijación
16	6102788M1	1	1	Bracket, Clamp	Bride de fixation	Brida de fijación
17	339229X1	1	2	Screw	Vis	Tornillo
18	1462583M1	1	1	Plate	Plaque	Placa
19	6102170M1	1	1	Bracket, Clamp	Bride de fixation	Brida de fijación
20	6102170M1	1	1	Bracket, Clamp	Bride de fixation	Brida de fijación
21	6109586M91	1	1	Dipperstick Assy	Ensemble de balancier	Balancín, Conj.
22	3510860M91	1	1	Kit, Shim	Jeu de cales	Juego de calces
23	3522720M2	1	1	Pin	Axe	Pasador

A Without Quick Attach
 Sans attache rapide
 Sin acoplamiento rápido



820 860 880 970 980
 TX760B TX860B

805 806 807 808 817 825 833 834 845 855 921 931

98061C01.1

6199042M3

1

Jan-06

Extendahoe Hydraulics Kit
Coffret de Circuit Hydraulique Extendahoe
Juego de circuito hidráulico Extendahoe

Sideshift
Montage de Pelle Latéral
Excavadora montaje horizontal

Control Pedal
Pédale de Commande
Pedal de control

C-98061-02.1-A

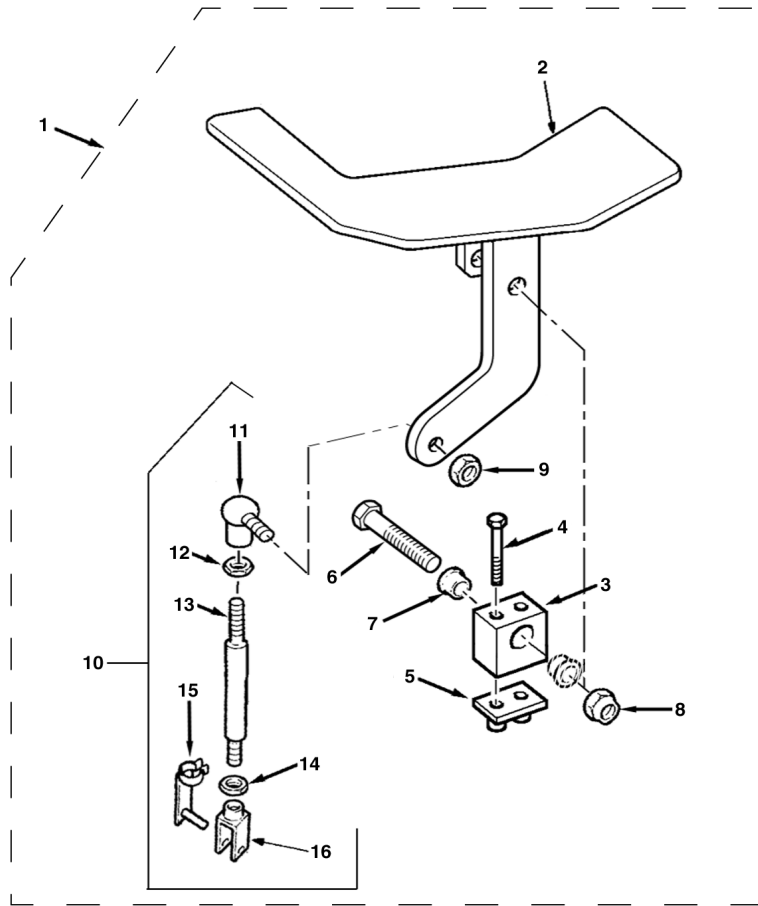

1	6110169M91		(A)Continued	1	Kit, Conversion	Jeu Conversion	Juego de conversion
2	6106874M91	1		1	Pedal Assy	Ensemble de pédale	Pedal, Conj.
3	6106734M1	1		1	Pivot	Pivot	Pivote
4	3001758X1	1	M6 x 50	2	Screw	Vis	Tornillo
5	3519538M1	1		1	Plate, Base	Plaque de base	Placa de base
6	6106981M1	1	M10 x 60	1	Bolt	Boulon	Perno
7	6106866M1	1		1	Bushing	Bague	Anillo
8	1440329X1	1	M10	1	Nut, Lock	Écrou de blocage	Tuerca de retención
9	394367X1	1	M8	1	Nut, Lock	Écrou de blocage	Tuerca de retención
10	6106724M92	1		1	Rod Assy	Ensemble tringlerie	Tirantes, Conj.
11	3517518M1	10		1	Ball Joint	Rotule	Rotula
12	339169X1	10	M8	1	Nut	Écrou	Tuerca
13		10	➡ Ref. 10	1	Rod	Tringle	Vástago
14	3519650M1	10	LH Thread M8 LH Thread	1	Nut	Écrou	Tuerca
15	3520666M1	10		1	Pin, Clevis	Axe de chape	Eje de brida
16	3519590M1	10	LH Thread LH Thread	1	Clevis	Chape	Brida
17	6101865M2	1		1	Decal	Adhésif	Adhesivo

A Without Quick Attach
 Sans attache rapide
 Sin acoplamiento rápido



820 860 880 970 980
 TX760B TX860B

805 806 807 808 817 825 833 834 845 855 921 931

98061C02.1

6199042M3

1

Jan-06

Extendahoe Hydraulics Kit
Coffret de Circuit Hydraulique Extendahoe
Juego de circuito hidráulico Extendahoe

Sideshift
Montage de Pelle Latéral
Excavadora montaje horizontal

With Auxiliary Hydraulics
Avec Hydraulique Auxiliaire
Con hidraulico auxiliar

C-98062-01.1-A

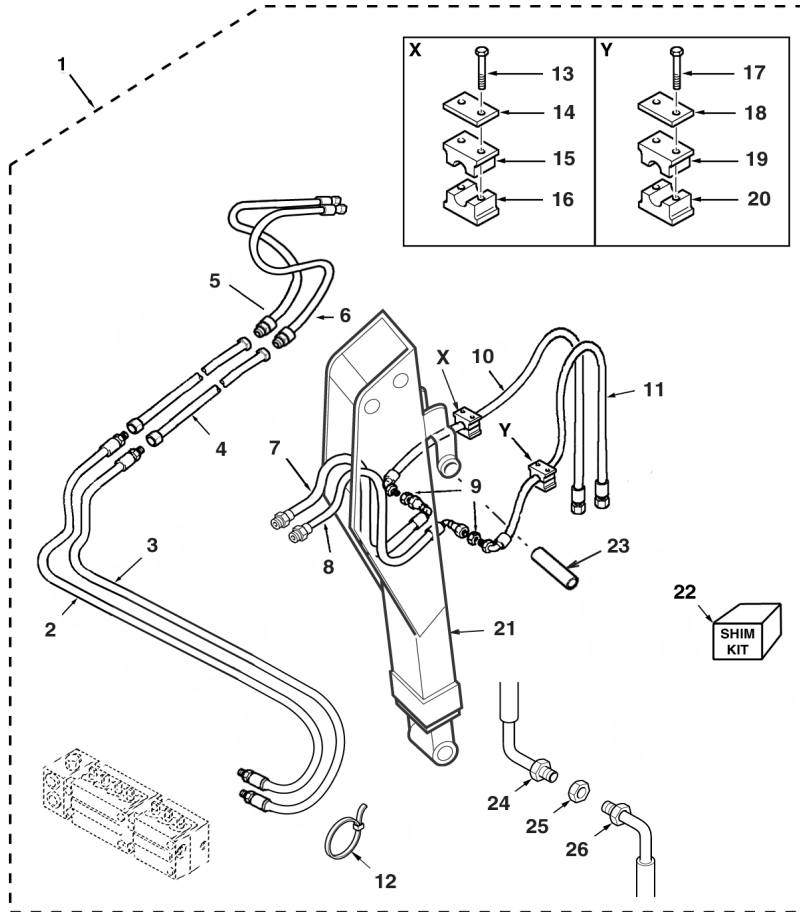

1	6110170M91	(A)	1	Kit, Conversion	Jeu Conversion	Juego de conversion
2	6108764M91	1	1	Hose Assy	Ensemble de flexible	Flexible, Conj.
3	6108765M91	1	1	Hose Assy	Ensemble de flexible	Flexible, Conj.
4	6101773M91	1	2	Tube Assy	Tuyauterie	Conjunto de tubería
5	6101741M91	1	1	Hose Assy	Ensemble de flexible	Flexible, Conj.
6	6101757M91	1	1	Hose Assy	Ensemble de flexible	Flexible, Conj.
7	6101739M91	1	1	Hose Assy	Ensemble de flexible	Flexible, Conj.
8	6101740M91	1	1	Hose Assy	Ensemble de flexible	Flexible, Conj.
9	355574X1	1	2	Nut	Écrou	Tuerca
10	6101007M91	1	1	Hose Assy	Ensemble de flexible	Flexible, Conj.
11	6101008M91	1	1	Hose Assy	Ensemble de flexible	Flexible, Conj.
12	1664405M1	1	5	Tie, Cable	Attache câble	Enlace de Cable
13	339229X1	1	2	Screw	Vis	Tornillo
14	1462583M1	1	1	Plate	Plaque	Placa
15	6102788M1	1	1	Bracket, Clamp	Bride de fixation	Brida de fijación
16	6102788M1	1	1	Bracket, Clamp	Bride de fixation	Brida de fijación
17	339229X1	1	2	Screw	Vis	Tornillo
18	1462583M1	1	1	Plate	Plaque	Placa
19	6102170M1	1	1	Bracket, Clamp	Bride de fixation	Brida de fijación
20	6102170M1	1	1	Bracket, Clamp	Bride de fixation	Brida de fijación
21	6109586M91	1	1	Dipperstick Assy	Ensemble de balancier	Balancín, Conj.
22	3510860M91	1	1	Kit, Shim	Jeu de cales	Juego de calces
23	3522720M2	1	1	Pin	Axe	Pasador
24	3521945M95	1	2	Hose Assy	Ensemble de flexible	Flexible, Conj.
25	356612X1	1	2	Nut	Écrou	Tuerca
26	6102922M91	1	2	Hose Assy	Ensemble de flexible	Flexible, Conj.

A With Quick Attach
 Avec attache rapide
 Con acoplamiento rápido



820 860 880 970 980
 TX760B TX860B

805 806 807 808 817 825 833 834 845 855 921 931

98062C01.1

6199042M3

1

Jan-06

Extendahoe Hydraulics Kit
Coffret de Circuit Hydraulique Extendahoe
Juego de circuito hidráulico Extendahoe

Sideshift
Montage de Pelle Latéral
Excavadora montaje horizontal

Control Pedal
Pédale de Commande
Pedal de control

C-98062-02.1-A

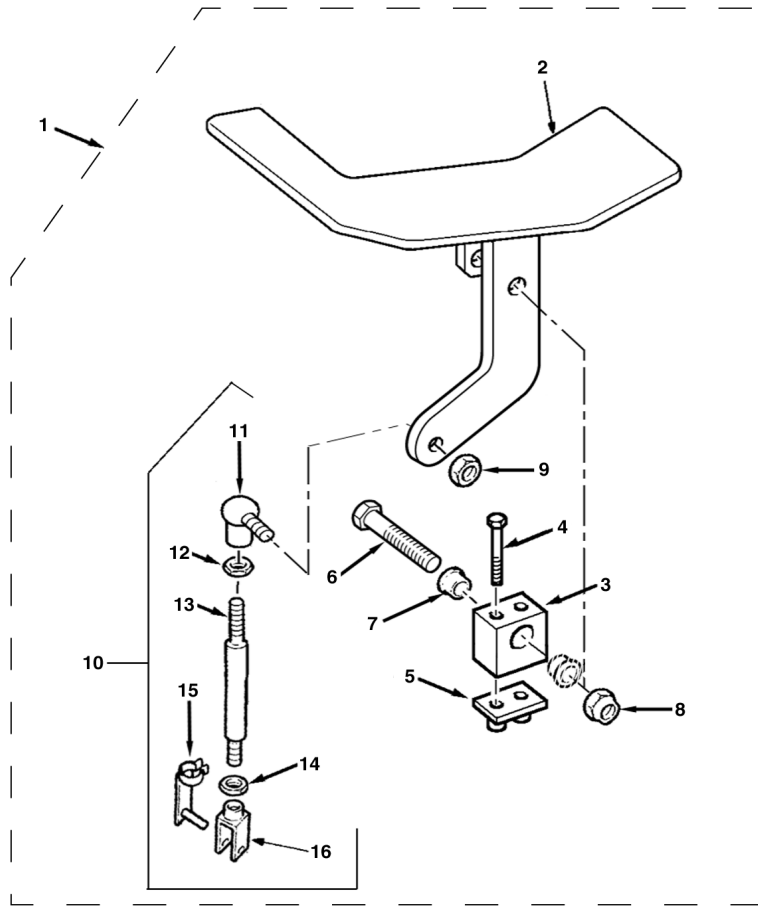

1	6110170M91		(A)Continued	1	Kit, Conversion	Jeu Conversion	Juego de conversion
2	6106874M91	1		1	Pedal Assy	Ensemble de pédale	Pedal, Conj.
3	6106734M1	1		1	Pivot	Pivot	Pivote
4	3001758X1	1	M6 x 50	2	Screw	Vis	Tornillo
5	3519538M1	1		1	Plate, Base	Plaque de base	Placa de base
6	6106981M1	1	M10 x 60	1	Bolt	Boulon	Perno
7	6106866M1	1		1	Bushing	Bague	Anillo
8	1440329X1	1	M10	1	Nut, Lock	Écrou de blocage	Tuerca de retención
9	394367X1	1	M8	1	Nut, Lock	Écrou de blocage	Tuerca de retención
10	6106724M92	1		1	Rod Assy	Ensemble tringlerie	Tirantes, Conj.
11	3517518M1	10		1	Ball Joint	Rotule	Rotula
12	339169X1	10	M8	1	Nut	Écrou	Tuerca
13		10	➡ Ref. 10	1	Rod	Tringle	Vástago
14	3519650M1	10	LH Thread M8 LH Thread	1	Nut	Écrou	Tuerca
15	3520666M1	10		1	Pin, Clevis	Axe de chape	Eje de brida
16	3519590M1	10	LH Thread LH Thread	1	Clevis	Chape	Brida
17	6101865M2	1		1	Decal	Adhésif	Adhesivo

A With Quick Attach
 Avec attache rapide
 Con acoplamiento rápido



820 860 880 970 980
 TX760B TX860B

805 806 807 808 817 825 833 834 845 855 921 931

98062C02.1

6199042M3

1

Jan-06

Fan Guard
 Protège-Ventilateur
 Protección ventilador

Without air conditioning
 Sans conditionneur
 Sin climatizador

C-95023-01.1-A

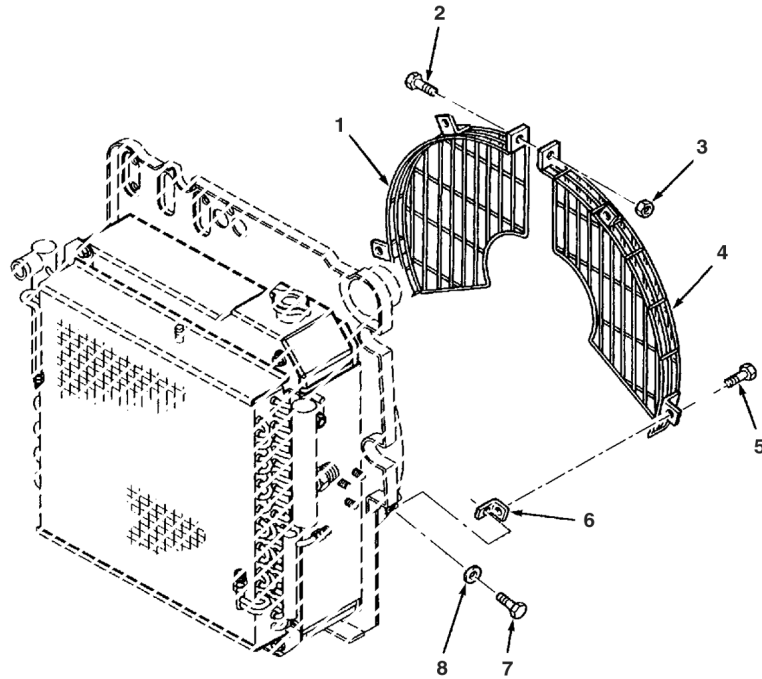

1	6110182M2	▶	1	Grating	Grille	Rejilla
2	339666X1	M6 x 20	1	Screw	Vis	Tornillo
3	1441500X1	M6	1	Nut, Lock	Écrou de blocage	Tuerca de retención
4	6110183M2	◀	1	Grating	Grille	Rejilla
5	391074X1	M6 x 12	4	Screw	Vis	Tornillo
6	3517435M2		4	Mount	Support de fixation	SopORTE de fijación
7	391074X1	M6 x 12	4	Screw	Vis	Tornillo
8	390971X1	M6	4	Washer	Rondelle	Arandela



880 980
 TX760B TX860B
 TX870B TX970B

832 833 834 841 842 843 844 845 851 852 853 854 855 931 932

95023C01.1

6199042M3

1

Jan-06

Fan Guard
Protège-Ventilateur
Protección ventilador

With air conditioning
 Avec conditionneur
 Con climatizador

C-95024-01.1-A

1	6110182M2	▶	1	Grating	Grille	Rejilla
2	339666X1	M6 x 20	1	Screw	Vis	Tornillo
3	1441500X1	M6	1	Nut, Lock	Écrou de blocage	Tuerca de retención
4	6110579M1	◀	1	Grating	Grille	Rejilla
5	391074X1	M6 x 12	4	Screw	Vis	Tornillo
6	3517435M2		4	Mount	Support de fixation	SopORTE de fijación
7	391074X1	M6 x 12	4	Screw	Vis	Tornillo
8	390971X1	M6	4	Washer	Rondelle	Arandela

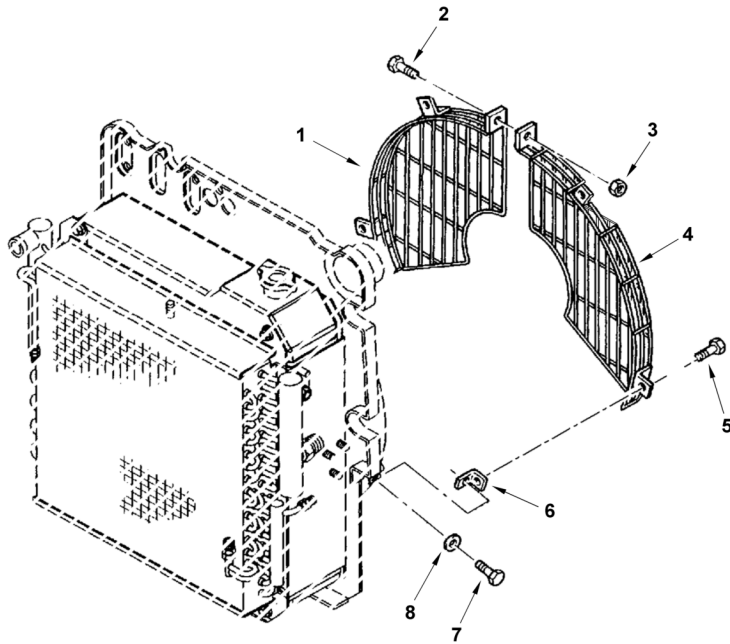

880 980
 TX760B TX860B
 TX870B TX970B

831 833 841 843 845 851 853 855 931 932

Fork Carrier
Chariot à fourches
Portador de horquilla

1	6110606M91	Fork	1	Carrier	Support	Portador
---	------------	------	---	---------	---------	----------

Not Illustrated

Non Illustrée

Nicht Abgebildet

Non Illustrato

No Ilustrado



880 980
TX860B TX870B
TX970B

841 842 843 844 845 851 852 853 854 855 931 932

Front Counterweight Kit
Coffret de Contrepoids Avant
Juego de contrapeso delantero

C-98001-01.1-A

1	6109016M1		1	Counterweight	Contrepoids	Contrapeso
2	339498X1	M16 x 110	4	Screw	Vis	Tornillo
3	3019575X1	M16	4	Washer	Rondelle	Arandela
4	1442739X1		4	Nut	Écrou	Tuerca

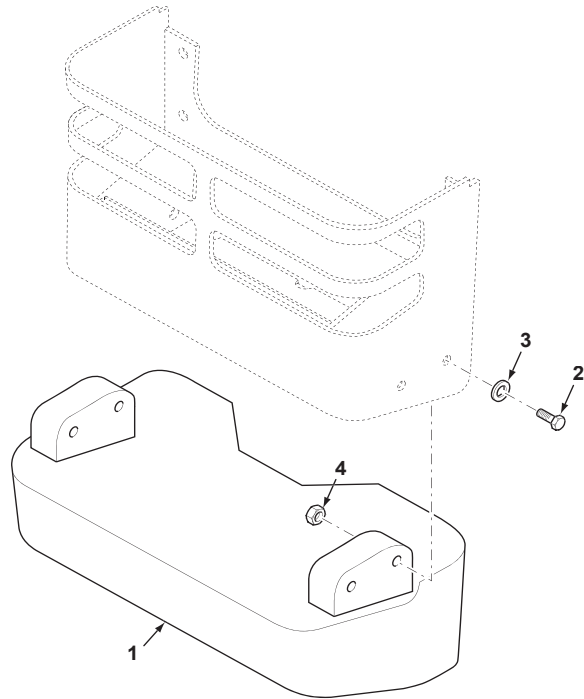

820 860 880
 TX760B TX860B
 TX870B

801 802 803 804 805 806 807 808 809 810 811 812 813 814 815 816 817 821 822
 823 824 825 831 832 833 834 841 842 843 844 845 851 852 853 854 855

Front Fenders
Ailes Avant
Alas delanteras

2 Wheel Steer
 2 Roues Directrices
 Dirección en 2 ruedas

C-63001-01.1-A

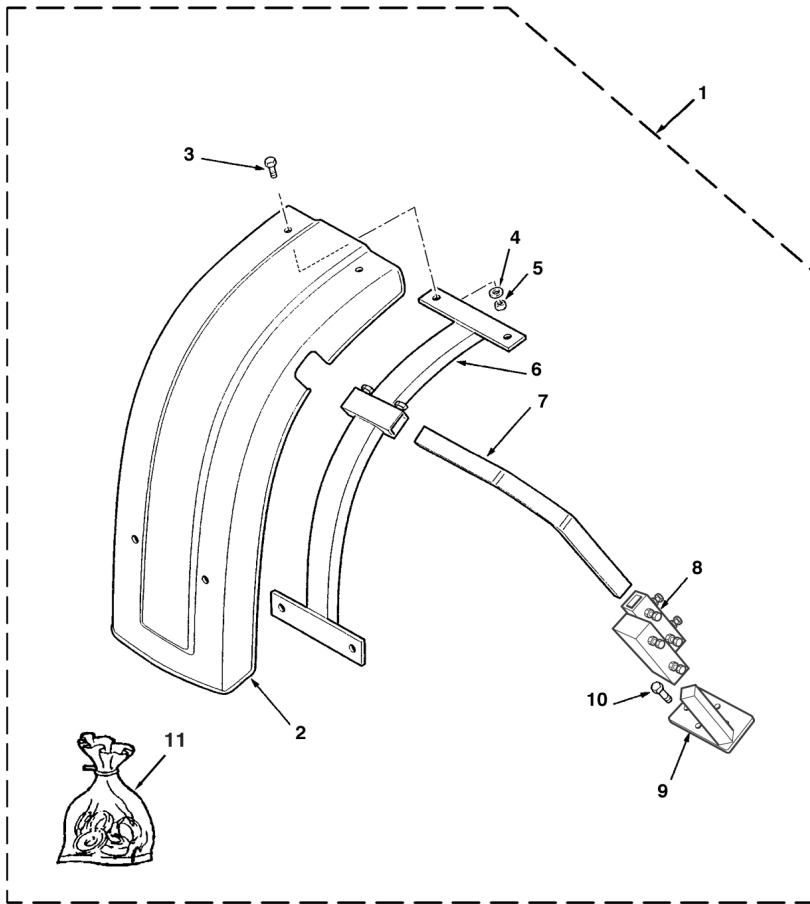

QTY	Part Number	Notes	QTY	Description	French Description	Spanish Description
1	6108376M91		1	Kit, Parts	Lot de pièces	Juego de piezas
2	3517767M1	1 ◀	1	Fender	Aile	Aleta
2	3517766M1	1 ▶	1	Fender	Aile	Aleta
3	3009331X1	1 (A) M6 x 25	8	Screw	Vis	Tornillo
4	391038X1	1 (A) M6	8	Washer	Rondelle	Arandela
5	339030X1	1 (A) M6	8	Nut	Écrou	Tuerca
6	3517762M91	1	2	Mount	Support de fixation	Soporte de fijación
7	6102351M1	1	2	Tube	Tube	Tubo
8	6108379M91	1 ◀	1	Support Assy	Ensemble de support	Apoyadero, Conj.
8	6108380M91	1 ▶	1	Support Assy	Ensemble de support	Apoyadero, Conj.
9	6108377M91	1 ◀	1	Mount	Support de fixation	Soporte de fijación
9	6108378M91	1 ▶	1	Mount	Support de fixation	Soporte de fijación
10	3000253X1	1 (A) M14 x 40	6	Bolt	Boulon	Perno
11	3517769M91	(B) Fastener Set	X	Kit, Parts	Lot de pièces	Juego de piezas

A Included in kit marked (B)
 Inclus dans jeu marqué (B)
 Incluido en juego marcado (B)

B Contains items marked (A)
 Comprend les pièces marquées (A)
 Incluye las piezas marcadas (A)



820 860 880
 TX760B TX860B
 TX870B

801 802 803 804 805 806 807 808 809 810 811 812 813 814 815 816 817 821 822
 823 824 825 831 832 833 834 841 842 843 844 845 851 852 853 854 855

63001C01.1

6199042M3

1

Jan-06

Front Fenders
Ailes Avant
Alas delanteras

4 Wheel Steer
 4 Roues Directrices
 Dirección en las 4 ruedas

C-63002-01.1-A

1	6101857M91			1	Kit, Parts	Lot de pièces	Juego de piezas
2	6101845M1	1	◀	1	Deflector, Mud	Garde-boue	Guardafango
2	6101846M1	1	▶	1	Deflector, Mud	Garde-boue	Guardafango
3	6101849M1	1		4	Screw	Vis	Tornillo
4	6101848M1	1		4	Spacer	Entretoise	Travesa
5	394367X1	1	M8	4	Nut, Lock	Écrou de blocage	Tuerca de retención
6	390972X1	1	M8	4	Washer	Rondelle	Arandela
7	6101843M91	1	◀	1	Mount	Support de fixation	Soporte de fijación
7	6101844M91	1	▶	1	Mount	Support de fixation	Soporte de fijación
8	339275X1	1	M16 x 35	4	Screw	Vis	Tornillo
9	6101847M91	1		2	Support	Support	Soporte
10	811-8020	1	M8 x 20	4	Screw	Vis	Tornillo
11	394367X1	1	M8	4	Nut, Lock	Écrou de blocage	Tuerca de retención
12	390972X1	1	M8	4	Washer	Rondelle	Arandela
13	339009X1	1	M8 x 35	4	Screw	Vis	Tornillo
14	390972X1	1	M8	4	Washer	Rondelle	Arandela
15	394367X1	1	M8	4	Nut, Lock	Écrou de blocage	Tuerca de retención

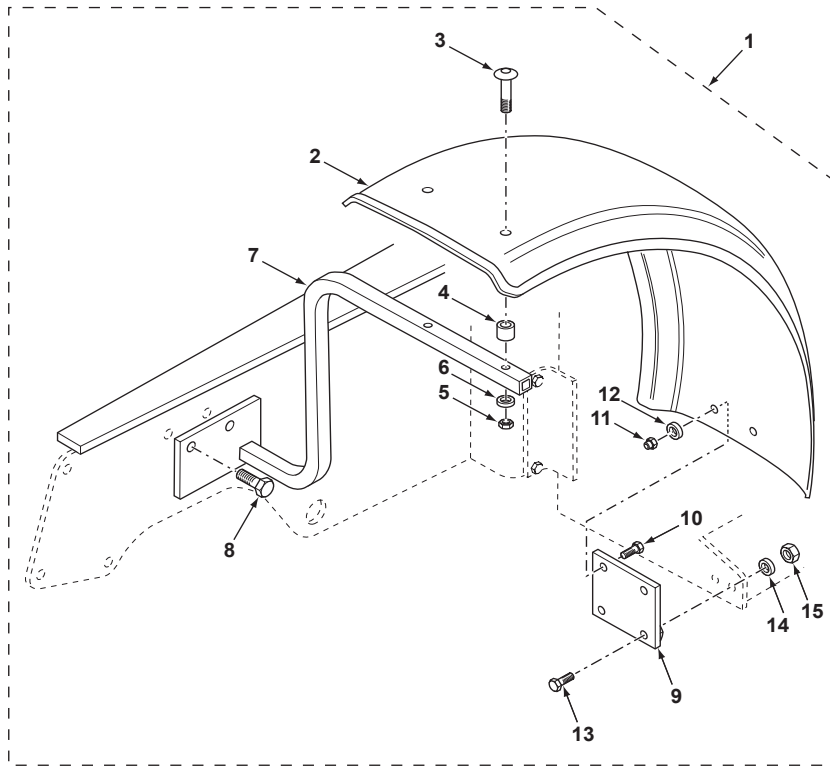

970 980
 TX970B

921 922 923 931 932

63002C01.1

6199042M3

1

Jan-06

Fuel Strainer Kit
Coffret de Crépine de Carburant
Juego de alcachofa de carburante

C-98071-01.1-A

1	3518545M1		1	Strainer	Crépine	Alcachofa
2	6106533M1		1	Washer	Rondelle	Arandela

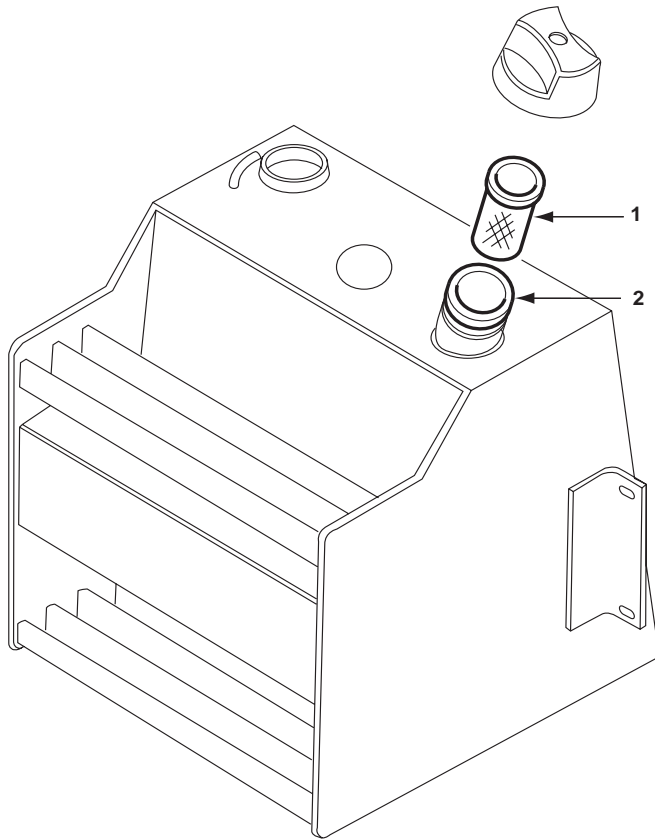

820 860 880 970 980
 TX760B TX860B
 TX870B TX970B

801 802 803 804 805 806 807 808 809 810 811 812 813 814 815 816 817 821 822
 823 824 825 831 832 833 834 841 842 843 844 845 851 852 853 854 855 921 922
 923 931 932

Grain/Snow Bucket
Godet à grains/neige
Cuchara de grano/nieve

1	6110607M91	Grain/Snow	1	Bucket	Godet	Cuchara
---	------------	------------	---	--------	-------	---------

Not Illustrated

Non Illustrée

Nicht Abgebildet

Non Illustrato

No Ilustrado



880 980
TX860B TX870B
TX970B

841 842 843 844 845 851 852 853 854 855 931 932

Guard Kit - Bonnet Grille
Kit de protection - Grille de capot
Kit de protector - Parrilla del capó

C-98126-01.1-A

1	6109492M91		1	Protector	Protection	Protección
2	6109504M1		1	Screen	Calandre	Calandra
3	391884X1	M6 x 50	2	Screw	Vis	Tornillo
4	391038X1	M6	2	Washer	Rondelle	Arandela
5	339666X1	M6 x 20	2	Screw	Vis	Tornillo
6	391038X1	M6	2	Washer	Rondelle	Arandela

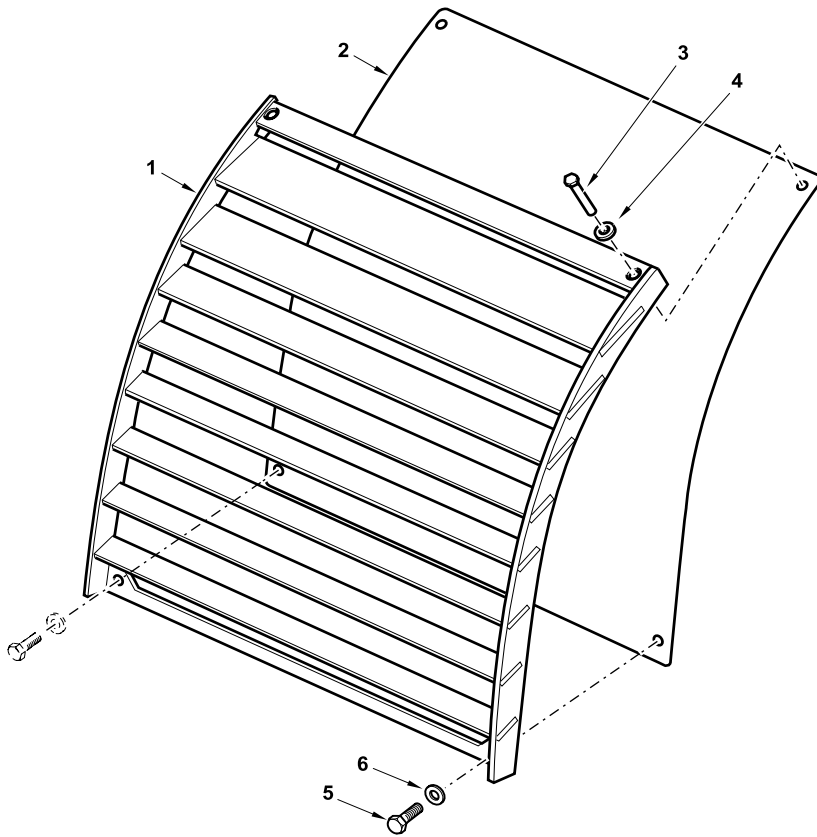

880 980
 TX760B TX860B
 TX870B TX970B

832 833 834 841 842 843 844 845 851 852 853 854 931 932

98126C01.1

6199042M3

1

Jan-06

Hose Burst Kit
Coffret de Éclatement de Tuyau
Juego de rotura de tubo flexible

Loader Arm Cylinder
Vérin de Bras Chargeur
Gato de brazo cargador

C-98038-01.1-A

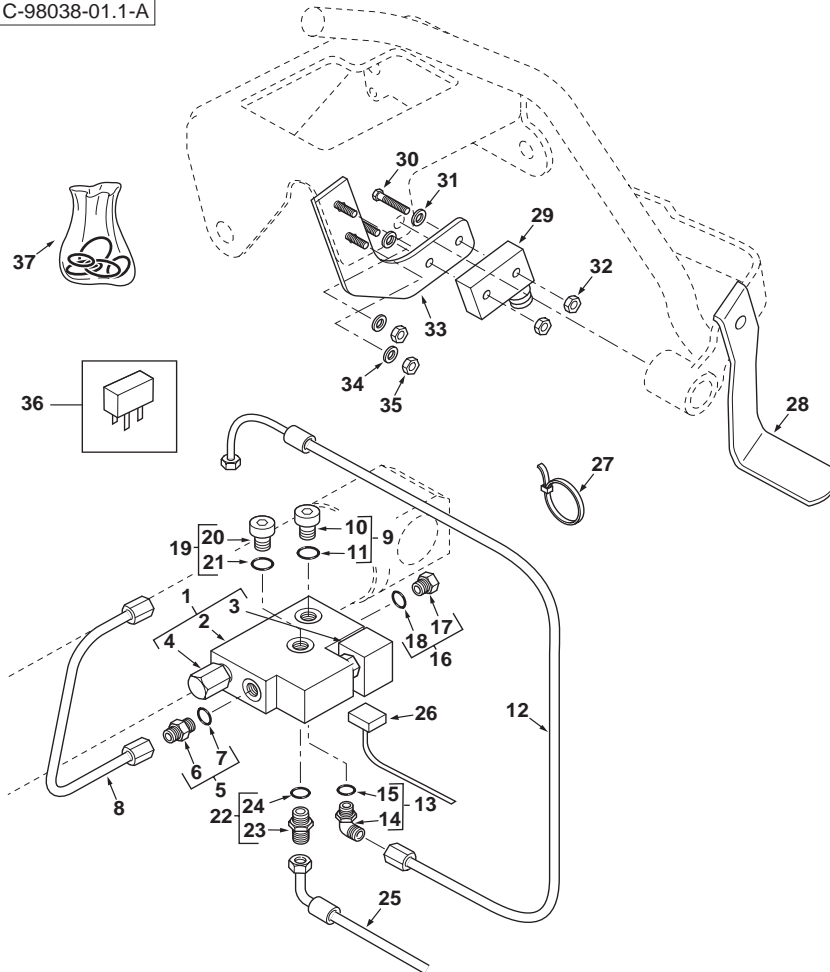

1	6109880M91		2	Valve, Lockout	Soupape verrouillage	Válvula de bloqueo.
2		1 (A) Ref. 1	1	Valve	Soupape	Válvula
3	6193308M91	1 (A) Solenoid	1	Cartridge	Cartouche	Cartucho
4	6193173M91	1 (A) Solenoid	1	Coil Assy	Ensemble de bobine	Bobina, Conj.
5	835013M91		2	Connector Assy	Ensemble connexion	Conexión, Conj.
6		5 Ref. 5	1	Connector	Connecteur	Conector
7	835024M1	5	1	O-Ring	Joint torique	Junta de tipo O
8	6109936M91		1	Tube Assy	Tuyauterie	Conjunto de tubería
8	6109938M91		1	Tube Assy	Tuyauterie	Conjunto de tubería
9	373772M91	9/16	2	Plug Assy	Ensemble bouchons	Tapón, Conj.
10		9 Ref. 9	1	Plug	Bouchon	Tapón
11	831452M1	9	1	O-Ring	Joint torique	Junta de tipo O
12	6109922M91		2	Hose Assy	Ensemble de flexible	Flexible, Conj.
13	357197X91		2	Elbow, 90°	Coude à 90°	Codo, 90°
14		10 Ref. 10	1	Elbow	Coude	Codo
15	831452M1	10	1	O-Ring	Joint torique	Junta de tipo O
16	6109935M91	7/8"	2	Connector Assy	Ensemble connexion	Conexión, Conj.
17		16 Ref. 16	1	Connector	Connecteur	Conector
18	835024M1	16	1	O-Ring	Joint torique	Junta de tipo O
19	373772M91	9/16	2	Plug Assy	Ensemble bouchons	Tapón, Conj.
20		19 Ref. 19	1	Plug	Bouchon	Tapón
21	831452M1	19	1	O-Ring	Joint torique	Junta de tipo O
22	6109947M91	9/16"	2	Restrictor	Réduction	Reducción
23		22 Ref. 22	1	Restrictor	Réduction	Reducción
24	831452M1	22	1	O-Ring	Joint torique	Junta de tipo O
25	6109923M91		1	Hose Assy	Ensemble de flexible	Flexible, Conj.
26	6102074M91		1	Harness	Faisceau	Haz
27	1664405M1		12	Tie, Cable	Attache câble	Enlace de Cable
28	6109603M1		1	Actuator	Vérin	Mecanismo de mando
29	6102075M91		1	Switch Assy	Ensemble commutat.	Conmutador, Conj.
30	3522433M2	M3 x 35	2	Screw	Vis	Tornillo
31	390752X1		2	Washer	Rondelle	Arandela
32	391216X1	M3	2	Nut	Écrou	Tuerca
33	6109602M91	Switch	1	Plate Assy	Ensemble de plaque	Placa, Conj.
34	390469X1	M5	2	Washer	Rondelle	Arandela
35	3005823X1	M5	2	Nut	Écrou	Tuerca
36	6102490M1		1	Relay	Relais	Relé
37	6194037M91	Lockout Valve	X	Kit, Seal	Pochette de joints	Juego de juntas

A Not illustrated
 Non illustrée
 No ilustrado



820 860 880 970 980
 TX760B TX860B
 TX870B TX970B

801 802 803 804 805 806 807 808 813 814 815 816 817 821 822 823 824 825 831
 832 833 834 841 842 843 844 845 851 852 853 854 855 921 922 923 931 932

98038C01.1

6199042M3

1

Jan-06

Hose Burst Kit
Coffret de Éclatement de Tuyau
Juego de rotura de tubo flexible

Loader Bucket Cylinder
Vérin de Godet Chargeur
Gato de cuchara

C-98038-02.1-A

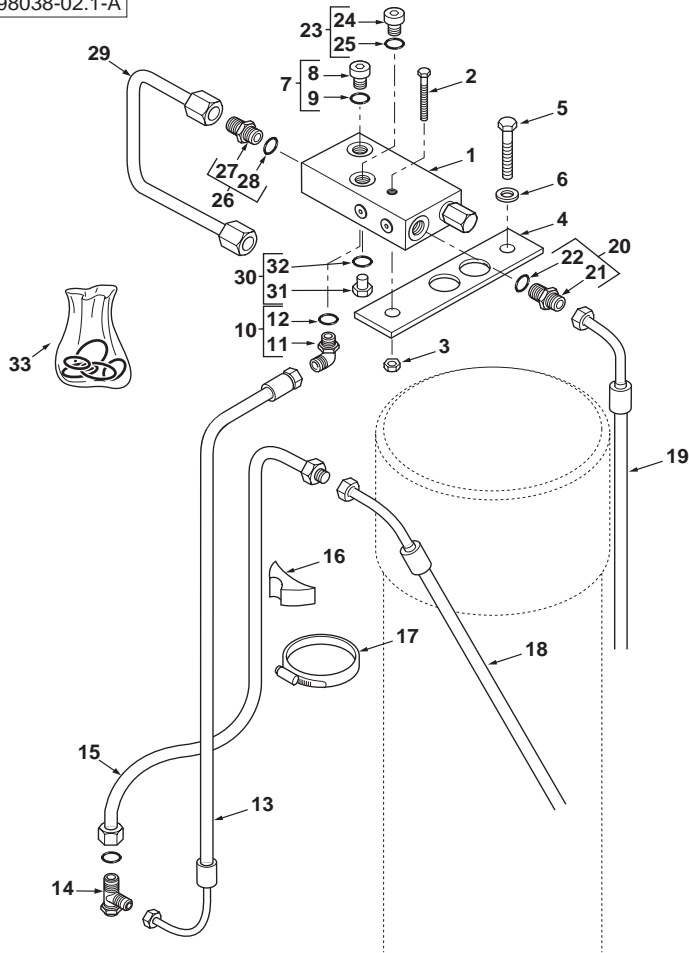

1	6109881M91		1	Valve, Lockout	Soupape verrouillage	Válvula de bloqueo.
2	339368X1	M8 x 60	2	Bolt, Lockout	Boulon	Perno
3	394367X1	M8	2	Nut, Lock	Écrou de blocage	Tuerca de retención
4	6109958M1		1	Plate	Plaque	Placa
5	3009505X1	M12 x 25	2	Bolt	Boulon	Perno
6	390735X1	M12	2	Washer	Rondelle	Arandela
7	373772M91	9/16	1	Plug Assy	Ensemble bouchons	Tapón, Conj.
8		8	1	Plug	Bouchon	Tapón
9	831452M1	8	1	O-Ring	Joint torique	Junta de tipo O
10	358781X91		1	Elbow, 45°	Coude à 45°	Codo, 45°
11		10	1	Elbow	Coude	Codo
12	831452M1	10	1	O-Ring	Joint torique	Junta de tipo O
13	6102015M91		1	Hose Assy	Ensemble de flexible	Flexible, Conj.
14	6102014M91		1	Tee	Raccord en T	Te
15	6106232M91		1	Tube Assy	Tuyauterie	Conjunto de tubería
16	L79937		1	Spacer	Entretoise	Traviesa
17	3517734M1		1	Clamp	Collier de serrage	Argolla de cierre
18	6102383M91		1	Hose Assy	Ensemble de flexible	Flexible, Conj.
19	6106233M92		1	Hose Assy	Ensemble de flexible	Flexible, Conj.
20	835013M91		1	Connector Assy	Ensemble connexion	Conexión, Conj.
21		20	1	Connector	Connecteur	Conector
22	835024M1	20	1	O-Ring	Joint torique	Junta de tipo O
23	373772M91	9/16	1	Plug Assy	Ensemble bouchons	Tapón, Conj.
24		23	1	Plug	Bouchon	Tapón
25	831452M1	23	1	O-Ring	Joint torique	Junta de tipo O
26	835013M91		1	Connector Assy	Ensemble connexion	Conexión, Conj.
27		26	1	Connector	Connecteur	Conector
28	835024M1	26	1	O-Ring	Joint torique	Junta de tipo O
29	6109956M91		1	Tube Assy	Tuyauterie	Conjunto de tubería
30	835087M91	9/16	1	Plug Assy	Ensemble bouchons	Tapón, Conj.
31		30	1	Plug	Bouchon	Tapón
32	831452M1	30	1	O-Ring	Joint torique	Junta de tipo O
33	6194038M91	Lockout Valve	X	Kit, Seal	Pochette de joints	Juego de juntas



820 860 880 970 980
 TX760B TX860B
 TX870B TX970B

801 802 803 804 805 806 807 808 813 814 815 816 817 821 822 823 824 825 831
 832 833 834 841 842 843 844 845 851 852 853 854 855 921 922 923 931 932

98038C02.1

6199042M3

1

Jan-06

Hose Burst Kit
Coffret de Éclatement de Tuyau
Juego de rotura de tubo flexible

Boom Cylinder
 Vérin de Flèche
 Gato de pluma

4.5m
 4.5m
 4.5m

C-98039-01.1-A

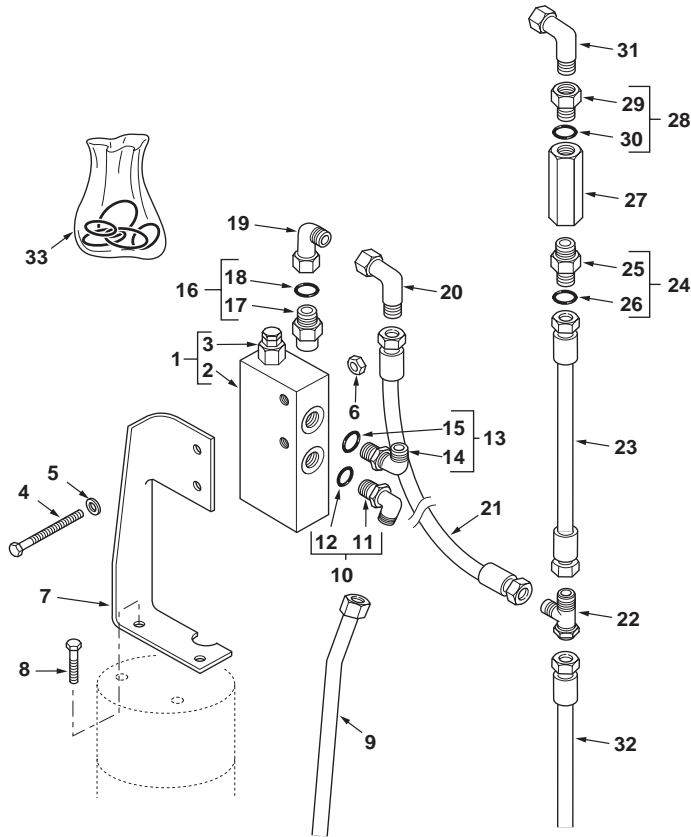

1	6109649M91		1	Valve, Lockout	Soupape verrouillage	Válvula de bloqueo.
2		1	▶ Ref. 1	1	Valve	Soupape
3	6194035M91	1	Bypass Relief	1	Cartridge Assy	Ensemble de cartouche
4	339368X1	M8 x 60		1	Bolt	Boulon
5	385361X1	M8		1	Washer	Rondelle
6	394367X1	M8		1	Nut, Lock	Écrou de blocage
7	6101960M1			1	Bracket	Patte de fixation
8	339123X1	M8 x 20		2	Bolt	Boulon
9	6101956M91			1	Tube Assy	Tuyauterie
10	835007M91			1	Elbow, 90°	Coude à 90°
11		10	▶ Ref. 10	1	Elbow	Coude
12	835024M1	10		1	O-Ring	Joint torique
13	835007M91			1	Elbow, 90°	Coude à 90°
14		13	▶ Ref. 13	1	Elbow	Coude
15	835024M1	13		1	O-Ring	Joint torique
16	835091M91	9/16		1	Union	Union
17		16	▶ Ref. 16	1	Connector	Connecteur
18	831452M1	16		1	O-Ring	Joint torique
19	364603X1	9/16		1	Elbow, 90°	Coude à 90°
20	364603X1	9/16		1	Elbow, 90°	Coude à 90°
21	6110438M91			1	Hose Assy	Ensemble de flexible
22	6102014M91			1	Tee	Raccord en T
23	6110437M91			1	Hose Assy	Ensemble de flexible
24	365715X91	1,1/16" - 7/8" UNF		1	Connector Assy	Ensemble connexion
25		24	▶ Ref. 24	1	Connector	Connecteur
26	835025M1	24		1	O-Ring	Joint torique
27	6109877M91			1	Valve, Check	Clapet anti-retour
28	6109944M91	1,1/16" - 7/8"		1	Connector Assy	Ensemble connexion
29		28	▶ Ref. 28	1	Connector	Connecteur
30		28	▶ Ref. 28	1	O-Ring	Joint torique
31	367386X1			1	Elbow, 90°	Coude à 90°
32	6101966M91			1	Hose Assy	Ensemble de flexible
33	6194034M91	Lockout Valve		1	Kit, Seal	Pochette de joints



820 860 880 970 980
 TX760B TX860B

801 802 803 804 805 806 807 808 813 814 817 821 822 825 831 832 833 834 841
 842 845 851 852 855 921 922 931

98039C01.1

6199042M3

1

Jan-06

Hose Burst Kit
Coffret de Éclatement de Tuyau
Juego de rotura de tubo flexible

Dipper Cylinder
 Vérin de Balancier
 Gato de balancín

4.5m
 4.5m
 4.5m

C-98039-02.1-A

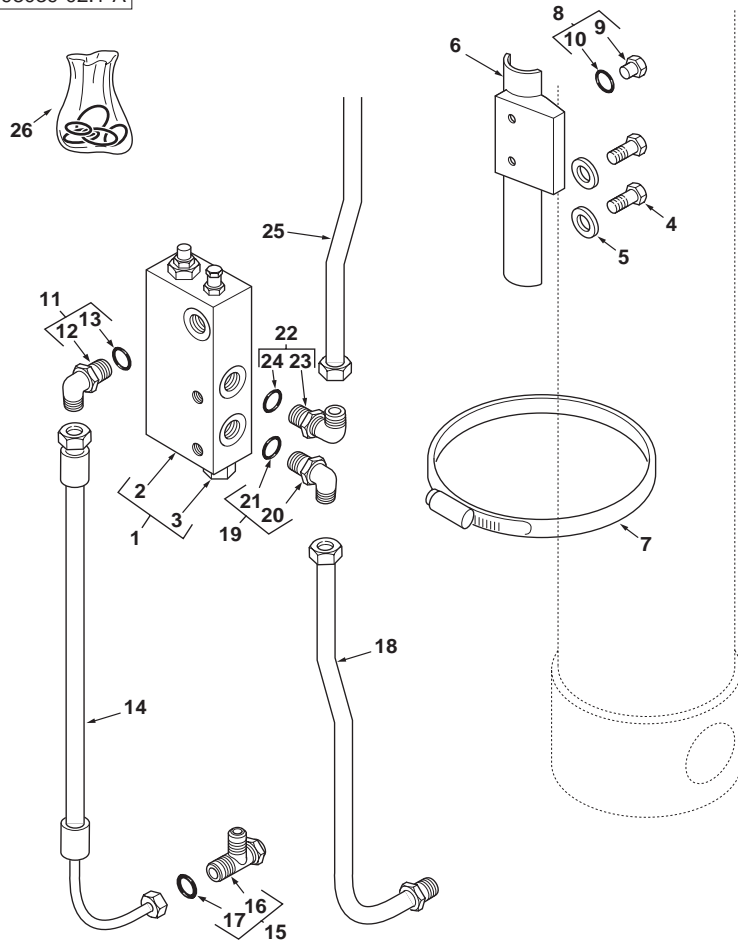

1	6109882M91		1	Valve, Lockout	Soupape verrouillage	Válvula de bloqueo.
2		1	▶ Ref. 1	Valve	Soupape	Válvula
3	6194035M91	1	Bypass Relief	Cartridge Assy	Ensemble de cartouche	Cartucho, Conj.
4	3009491X1	M10 x 20	2	Screw	Vis	Tornillo
5	390734X1	M10	2	Washer	Rondelle	Arandela
6	6110008M91		1	Bracket Assy	Ensemble chaise palier	Cuchara, Conj.
7	3517731M1		2	Clip, Mounting	Collier de fixation	Argolla de fijación
8	373772M91	9/16	1	Plug Assy	Ensemble bouchons	Tapón, Conj.
9		9	▶ Ref. 9	Plug	Bouchon	Tapón
10	831452M1	9	1	O-Ring	Joint torique	Junta de tipo O
11	357197X91		1	Elbow, 90°	Coude à 90°	Codo, 90°
12		11	▶ Ref. 11	Elbow	Coude	Codo
13	831452M1	11	1	O-Ring	Joint torique	Junta de tipo O
14	6101955M91		1	Hose Assy	Ensemble de flexible	Flexible, Conj.
15	6101954M91		1	Tee	Raccord en T	Te
16		15	▶ Ref. 15	Tee	Raccord en T	Te
17	835024M1	15	1	O-Ring	Joint torique	Junta de tipo O
18	6110004M91		1	Tube Assy	Tuyauterie	Conjunto de tubería
19	835007M91		1	Elbow, 90°	Coude à 90°	Codo, 90°
20		19	▶ Ref. 19	Elbow	Coude	Codo
21	835024M1	19	1	O-Ring	Joint torique	Junta de tipo O
22	6101624M91		1	Elbow, 90°	Coude à 90°	Codo, 90°
23		22	▶ Ref. 22	Elbow	Coude	Codo
24	835024M1	22	1	O-Ring	Joint torique	Junta de tipo O
25	6110006M91		1	Tube Assy	Tuyauterie	Conjunto de tubería
26	6194036M91		X	Lockout Valve	Pochette de joints	Juego de juntas



820 860 880 970 980
 TX760B TX860B

801 802 803 804 805 806 807 808 813 814 817 821 822 825 831 832 833 834 841
 842 845 851 852 855 921 922 931

98039C02.1

6199042M3

1

Jan-06

Hose Burst Kit
Coffret de Éclatement de Tuyau
Juego de rotura de tubo flexible

Boom Cylinder
 Vérin de Flèche
 Gato de pluma

4.9m
 4.9m
 4.9m

C-98040-01.1-A

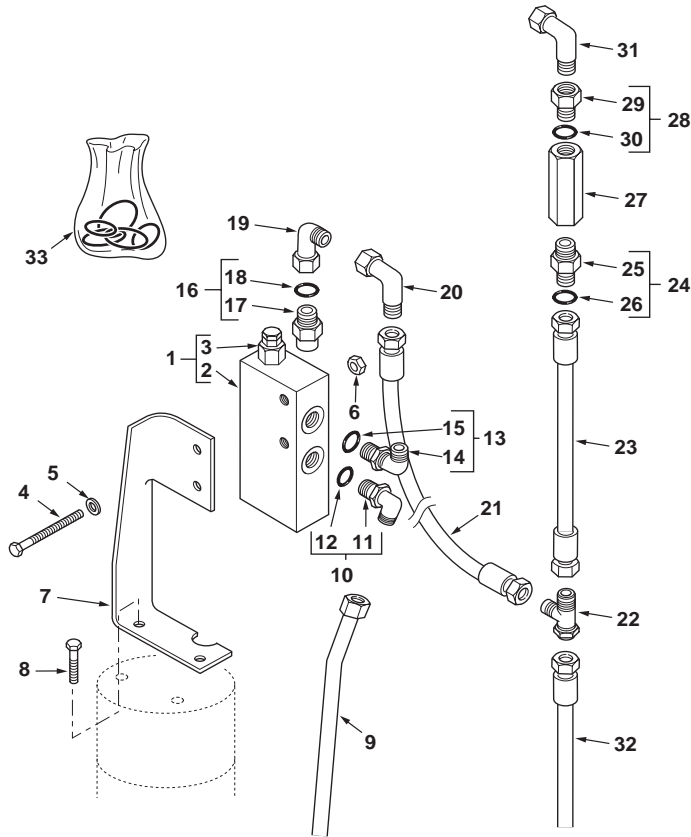

1	6109649M91		1	Valve, Lockout	Soupape verrouillage	Válvula de bloqueo.
2		1	▶ Ref. 1	1	Valve	Soupape
3	6194035M91	1	Bypass Relief	1	Cartridge Assy	Ensemble de cartouche
4	339368X1	M8 x 60		1	Bolt	Boulon
5	385361X1	M8		1	Washer	Rondelle
6	394367X1	M8		1	Nut, Lock	Écrou de blocage
7	6101960M1			1	Bracket	Patte de fixation
8	339123X1	M8 x 20		2	Bolt	Boulon
9	6102472M91			1	Tube Assy	Tuyauterie
10	835007M91			1	Elbow, 90°	Coude à 90°
11		10	▶ Ref. 10	1	Elbow	Coude
12	835024M1	10		1	O-Ring	Joint torique
13	835007M91			1	Elbow, 90°	Coude à 90°
14		13	▶ Ref. 13	1	Elbow	Coude
15	835024M1	13		1	O-Ring	Joint torique
16	835091M91	9/16		1	Union	Union
17		16	▶ Ref. 16	1	Connector	Connecteur
18	831452M1	16		1	O-Ring	Joint torique
19	364603X1	9/16		1	Elbow, 90°	Coude à 90°
20	364603X1	9/16		1	Elbow, 90°	Coude à 90°
21	6110438M91			1	Hose Assy	Ensemble de flexible
22	6102014M91			1	Tee	Raccord en T
23	6110437M91			1	Hose Assy	Ensemble de flexible
24	365715X91	1,1/16" - 7/8" UNF		1	Connector Assy	Ensemble connexion
25		24	▶ Ref. 24	1	Connector	Connecteur
26	835025M1	24		1	O-Ring	Joint torique
27	6109877M91			1	Valve, Check	Clapet anti-retour
28	6109944M91	1,1/16" - 7/8"		1	Connector Assy	Ensemble connexion
29		28	▶ Ref. 28	1	Connector	Connecteur
30		28	▶ Ref. 28	1	O-Ring	Joint torique
31	367386X1			1	Elbow, 90°	Coude à 90°
32	6101966M91			1	Hose Assy	Ensemble de flexible
33	6194034M91	Lockout Valve		1	Kit, Seal	Pochette de joints



860 880 970 980
 TX870B TX970B

815 816 823 824 843 844 853 854 923 932

98040C01.1

6199042M3

1

Jan-06

Hose Burst Kit
Coffret de Éclatement de Tuyau
Juego de rotura de tubo flexible

Dipper Cylinder
 Vérin de Balancier
 Gato de balancín

4.9m
 4.9m
 4.9m

C-98040-02.1-A

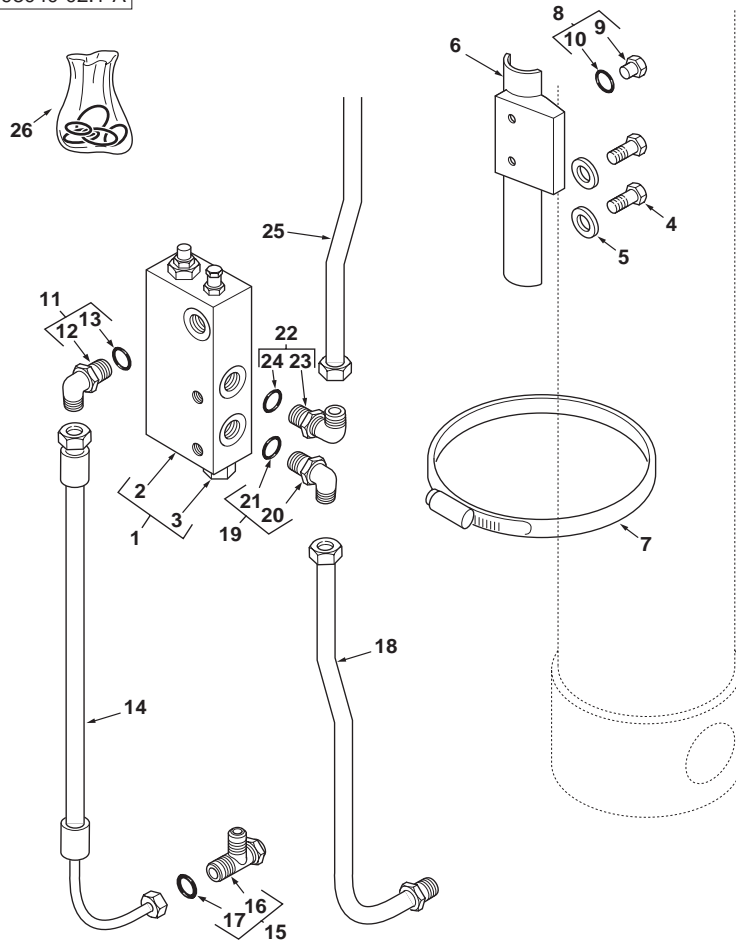

1	6109882M91		1	Valve, Lockout	Soupape verrouillage	Válvula de bloqueo.
2		1	▶ Ref. 1	1	Valve	Soupape
3	6194035M91	1	Bypass Relief	1	Cartridge Assy	Ensemble de cartouche
4	3009491X1		M10 x 20	2	Screw	Vis
5	390734X1		M10	2	Washer	Rondelle
6	6110008M91			1	Bracket Assy	Ensemble chaise palier
7	3517731M1			2	Clip, Mounting	Collier de fixation
8	373772M91		9/16	1	Plug Assy	Ensemble bouchons
9		9	▶ Ref. 9	1	Plug	Bouchon
10	831452M1	9		1	O-Ring	Joint torique
11	357197X91			1	Elbow, 90°	Coude à 90°
12		11	▶ Ref. 11	1	Elbow	Coude
13	831452M1	11		1	O-Ring	Joint torique
14	6101955M91			1	Hose Assy	Ensemble de flexible
15	6101954M91			1	Tee	Raccord en T
16		15	▶ Ref. 15	1	Tee	Raccord en T
17	835024M1	15		1	O-Ring	Joint torique
18	6110004M91			1	Tube Assy	Tuyauterie
19	835007M91			1	Elbow, 90°	Coude à 90°
20		19	▶ Ref. 19	1	Elbow	Coude
21	835024M1	19		1	O-Ring	Joint torique
22	6101624M91			1	Elbow, 90°	Coude à 90°
23				1	Elbow	Coude
24	835024M1			1	O-Ring	Joint torique
25	6110006M91			1	Tube Assy	Tuyauterie
26	6194036M91		Lockout Valve	X	Kit, Seal	Pochette de joints



860 880 970 980
 TX870B TX970B

815 816 823 824 843 844 853 854 923 932

98040C02.1

6199042M3

1

Jan-06

Hose Burst Kit
Coffret de Éclatement de Tuyau
Juego de rotura de tubo flexible

Loader Arm Cylinder
Vérin de Bras Chargeur
Gato de brazo cargador

4.5m
 4.5m
 4.5m

C-98057-01.1-A

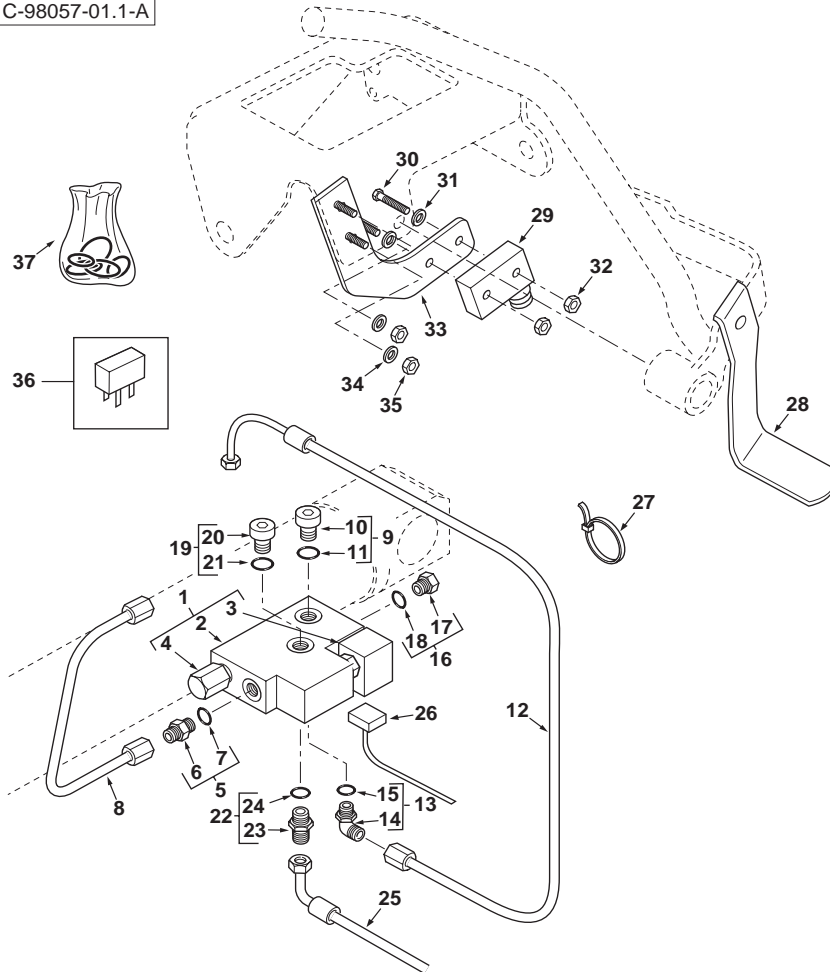

1	6109880M91		2	Valve, Lockout	Soupape verrouillage	Válvula de bloqueo.
2		1 (A) ▶ Ref. 1	1	Valve	Soupape	Válvula
3	6193308M91	1 (A) Solenoid	1	Cartridge	Cartouche	Cartucho
4	6193173M91	1 (A) Solenoid	1	Coil Assy	Ensemble de bobine	Bobina, Conj.
5	835013M91		2	Connector Assy	Ensemble connexion	Conexión, Conj.
6		5 ▶ Ref. 5	1	Connector	Connecteur	Conector
7	835024M1	5	1	O-Ring	Joint torique	Junta de tipo O
8	6109936M91	◀	1	Tube Assy	Tuyauterie	Conjunto de tubería
8	6109938M91	▶	1	Tube Assy	Tuyauterie	Conjunto de tubería
9	373772M91	9/16	2	Plug Assy	Ensemble bouchons	Tapón, Conj.
10		9 ▶ Ref. 9	1	Plug	Bouchon	Tapón
11	831452M1	9	1	O-Ring	Joint torique	Junta de tipo O
12	6109922M91		2	Hose Assy	Ensemble de flexible	Flexible, Conj.
13	357197X91		2	Elbow, 90°	Coude à 90°	Codo, 90°
14		10 ▶ Ref. 10	1	Elbow	Coude	Codo
15	831452M1	10	1	O-Ring	Joint torique	Junta de tipo O
16	6109935M91	7/8"	2	Connector Assy	Ensemble connexion	Conexión, Conj.
17		16 ▶ Ref. 16	1	Connector	Connecteur	Conector
18	835024M1	16	1	O-Ring	Joint torique	Junta de tipo O
19	373772M91	9/16	2	Plug Assy	Ensemble bouchons	Tapón, Conj.
20		19 ▶ Ref. 19	1	Plug	Bouchon	Tapón
21	831452M1	19	1	O-Ring	Joint torique	Junta de tipo O
22	6109947M91	9/16"	2	Restrictor	Réduction	Reducción
23		22 ▶ Ref. 22	1	Restrictor	Réduction	Reducción
24	831452M1	22	1	O-Ring	Joint torique	Junta de tipo O
25	6109923M91		1	Hose Assy	Ensemble de flexible	Flexible, Conj.
26	6102074M91		1	Harness	Faisceau	Haz
27	1664405M1		12	Tie, Cable	Attache câble	Enlace de Cable
28	6109603M1		1	Actuator	Vérin	Mecanismo de mando
29	6102075M91		1	Switch Assy	Ensemble commutat.	Conmutador, Conj.
30	3522433M2	M3 x 35	2	Screw	Vis	Tornillo
31	390752X1		2	Washer	Rondelle	Arandela
32	391216X1	M3	2	Nut	Écrou	Tuerca
33	6109602M91	Switch	1	Plate Assy	Ensemble de plaque	Placa, Conj.
34	390469X1	M5	2	Washer	Rondelle	Arandela
35	3005823X1	M5	2	Nut	Écrou	Tuerca
36	6102490M1		1	Relay	Relais	Relé
37	6194037M91	Lockout Valve	X	Kit, Seal	Pochette de joints	Juego de juntas

A Not illustrated
 Non illustrée
 No ilustrado



820 860 970
 TX760B TX860B

801 802 803 804 805 806 807 808 813 814 817 821 822 825 921 922

98057C01.1

6199042M3

1

Jan-06

Hose Burst Kit
Coffret de Éclatement de Tuyau
Juego de rotura de tubo flexible

Loader Bucket Cylinder
 Vérin de Godet Chargeur
 Gato de cuchara

4.5m
 4.5m
 4.5m

C-98057-02.1-A

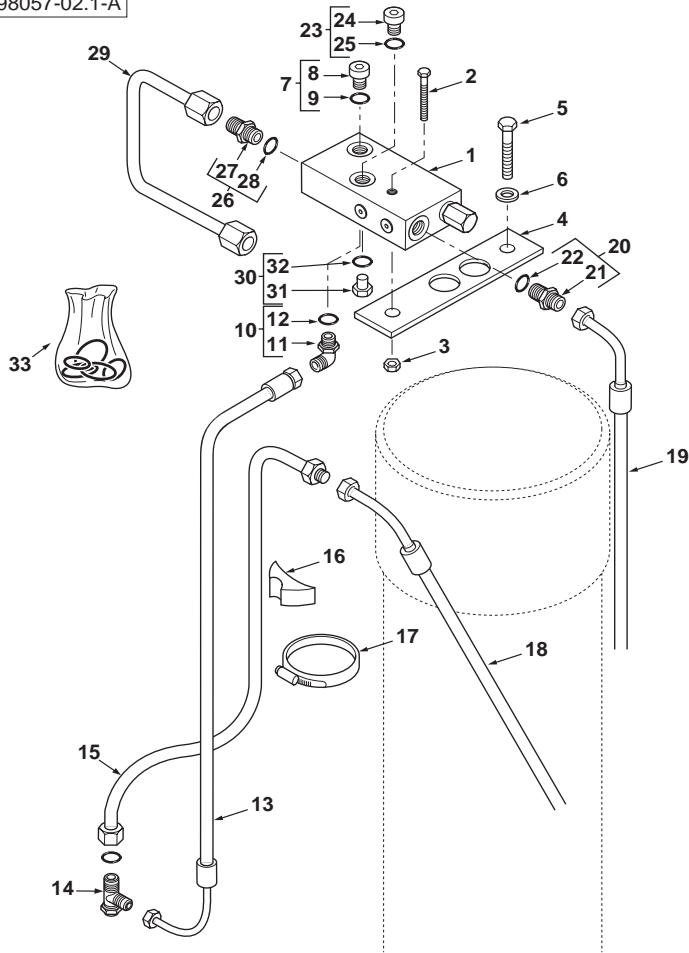

1	6109881M91		1	Valve, Lockout	Soupape verrouillage	Válvula de bloqueo.
2	339368X1	M8 x 60	2	Bolt, Lockout	Boulon	Perno
3	394367X1	M8	2	Nut, Lock	Écrou de blocage	Tuerca de retención
4	6109958M1		1	Plate	Plaque	Placa
5	3009505X1	M12 x 25	2	Bolt	Boulon	Perno
6	390735X1	M12	2	Washer	Rondelle	Arandela
7	373772M91	9/16	1	Plug Assy	Ensemble bouchons	Tapón, Conj.
8		8	1	Plug	Bouchon	Tapón
9	831452M1	8	1	O-Ring	Joint torique	Junta de tipo O
10	358781X91		1	Elbow, 45°	Coude à 45°	Codo, 45°
11		10	1	Elbow	Coude	Codo
12	831452M1	10	1	O-Ring	Joint torique	Junta de tipo O
13	6102015M91		1	Hose Assy	Ensemble de flexible	Flexible, Conj.
14	6102014M91		1	Tee	Raccord en T	Te
15	6106232M91		1	Tube Assy	Tuyauterie	Conjunto de tubería
16	L79937		1	Spacer	Entretoise	Traviesa
17	3517734M1		1	Clamp	Collier de serrage	Argolla de cierre
18	6102383M91		1	Hose Assy	Ensemble de flexible	Flexible, Conj.
19	6106233M92		1	Hose Assy	Ensemble de flexible	Flexible, Conj.
20	835013M91		1	Connector Assy	Ensemble connexion	Conexión, Conj.
21		20	1	Connector	Connecteur	Conector
22	835024M1	20	1	O-Ring	Joint torique	Junta de tipo O
23	373772M91	9/16	1	Plug Assy	Ensemble bouchons	Tapón, Conj.
24		23	1	Plug	Bouchon	Tapón
25	831452M1	23	1	O-Ring	Joint torique	Junta de tipo O
26	835013M91		1	Connector Assy	Ensemble connexion	Conexión, Conj.
27		26	1	Connector	Connecteur	Conector
28	835024M1	26	1	O-Ring	Joint torique	Junta de tipo O
29	6109956M91		1	Tube Assy	Tuyauterie	Conjunto de tubería
30	373772M91	9/16	1	Plug Assy	Ensemble bouchons	Tapón, Conj.
31		30	1	Plug	Bouchon	Tapón
32	831452M1	30	1	O-Ring	Joint torique	Junta de tipo O
33	6194038M91	Lockout Valve	X	Kit, Seal	Pochette de joints	Juego de juntas



820 860 970
 TX760B TX860B

801 802 803 804 805 806 807 808 813 814 817 821 822 825 921 922

98057C02.1

6199042M3

1

Jan-06

Hose Burst Kit
Coffret de Éclatement de Tuyau
Juego de rotura de tubo flexible

Boom Cylinder
 Vérin de Flèche
 Gato de pluma

4.5m
 4.5m
 4.5m

C-98057-03.1-A

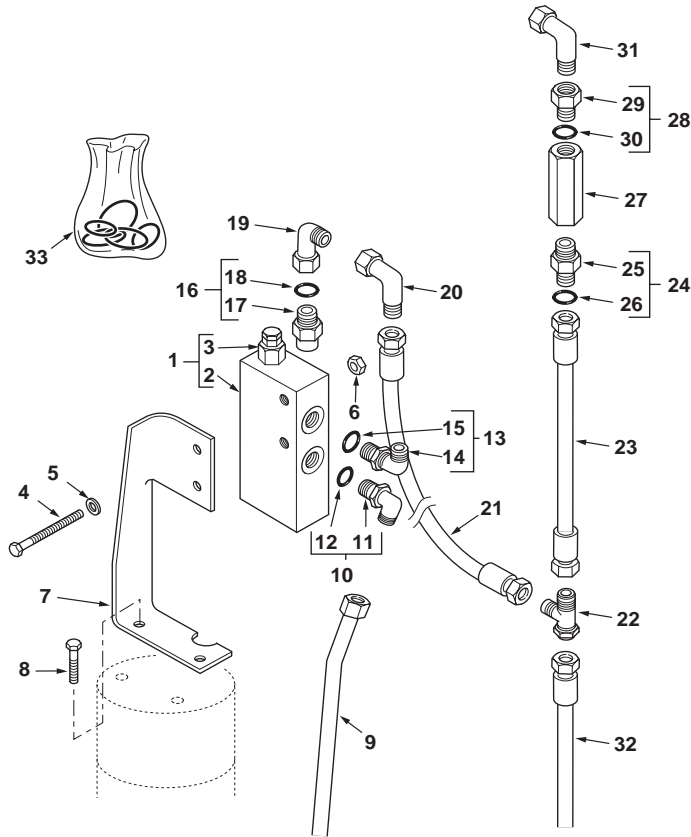

1	6109649M91		1	Valve, Lockout	Soupape verrouillage	Válvula de bloqueo.
2		1	▶ Ref. 1	1	Valve	Soupape
3	6194035M91	1	Bypass Relief	1	Cartridge Assy	Ensemble de cartouche
4	339368X1	M8 x 60		1	Bolt	Boulon
5	385361X1	M8		1	Washer	Rondelle
6	394367X1	M8		1	Nut, Lock	Écrou de blocage
7	6101960M1			1	Bracket	Patte de fixation
8	339123X1	M8 x 20		2	Bolt	Boulon
9	6101956M91			1	Tube Assy	Tuyauterie
10	835007M91			1	Elbow, 90°	Coude à 90°
11		10	▶ Ref. 10	1	Elbow	Coude
12	835024M1	10		1	O-Ring	Joint torique
13	835007M91			1	Elbow, 90°	Coude à 90°
14		13	▶ Ref. 13	1	Elbow	Coude
15	835024M1	13		1	O-Ring	Joint torique
16	835091M91	9/16		1	Union	Union
17		16	▶ Ref. 16	1	Connector	Connecteur
18	831452M1	16		1	O-Ring	Joint torique
19	364603X1	9/16		1	Elbow, 90°	Coude à 90°
20	364603X1	9/16		1	Elbow, 90°	Coude à 90°
21	6110438M91			1	Hose Assy	Ensemble de flexible
22	6102014M91			1	Tee	Raccord en T
23	6110437M91			1	Hose Assy	Ensemble de flexible
24	365715X91	1,1/16" - 7/8" UNF		1	Connector Assy	Ensemble connexion
25		24	▶ Ref. 24	1	Connector	Connecteur
26	835025M1	24		1	O-Ring	Joint torique
27	6109877M91			1	Valve, Check	Clapet anti-retour
28	6109944M91	1,1/16" - 7/8"		1	Connector Assy	Ensemble connexion
29		28	▶ Ref. 28	1	Connector	Connecteur
30		28	▶ Ref. 28	1	O-Ring	Joint torique
31	367386X1			1	Elbow, 90°	Coude à 90°
32	6101966M91			1	Hose Assy	Ensemble de flexible
33	6194034M91	Lockout Valve		1	Kit, Seal	Pochette de joints



820 860 970
 TX760B TX860B

801 802 803 804 805 806 807 808 813 814 817 821 822 825 921 922

98057C03.1

6199042M3

1

Jan-06

Hose Burst Kit
Coffret de Éclatement de Tuyau
Juego de rotura de tubo flexible

Dipper Cylinder
 Vérin de Balancier
 Gato de balancín

4.5m
 4.5m
 4.5m

C-98057-04.1-A

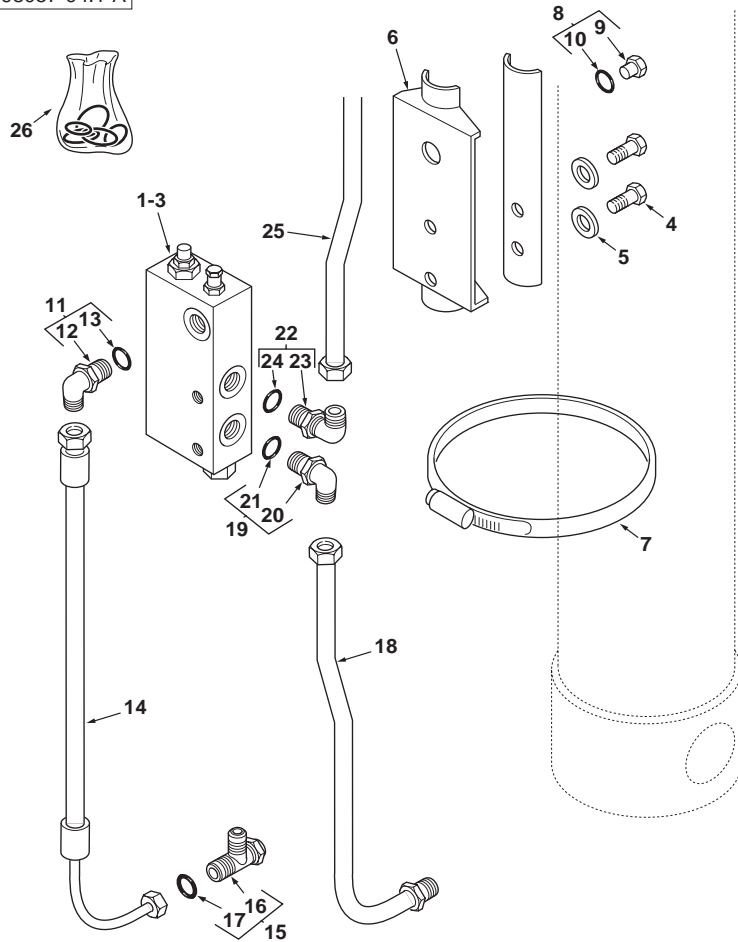

1	6109882M91		1	Valve, Lockout	Soupape verrouillage	Válvula de bloqueo.
2		1	▶ Ref. 1	1 Valve	Soupape	Válvula
3	6194035M91	1	Bypass Relief	1 Cartridge Assy	Ensemble de cartouche	Cartucho, Conj.
4	3009491X1		M10 x 20	2 Screw	Vis	Tornillo
5	390734X1		M10	2 Washer	Rondelle	Arandela
6	6110008M91			1 Bracket Assy	Ensemble chaise palier	Cuchara, Conj.
7	3517731M1			2 Clip, Mounting	Collier de fixation	Argolla de fijación
8	373772M91		9/16	1 Plug Assy	Ensemble bouchons	Tapón, Conj.
9		9	▶ Ref. 9	1 Plug	Bouchon	Tapón
10	831452M1	9		1 O-Ring	Joint torique	Junta de tipo O
11	357197X91			1 Elbow, 90°	Coude à 90°	Codo, 90°
12		11	▶ Ref. 11	1 Elbow	Coude	Codo
13	831452M1	11		1 O-Ring	Joint torique	Junta de tipo O
14	6101955M91			1 Hose Assy	Ensemble de flexible	Flexible, Conj.
15	6101954M91			1 Tee	Raccord en T	Te
16		15	▶ Ref. 15	1 Tee	Raccord en T	Te
17	835024M1	15		1 O-Ring	Joint torique	Junta de tipo O
18	6110004M91			1 Tube Assy	Tuyauterie	Conjunto de tubería
19	835007M91			1 Elbow, 90°	Coude à 90°	Codo, 90°
20		19	▶ Ref. 19	1 Elbow	Coude	Codo
21	835024M1	19		1 O-Ring	Joint torique	Junta de tipo O
22	6101624M91			1 Elbow, 90°	Coude à 90°	Codo, 90°
23				1 Elbow	Coude	Codo
24	835024M1			1 O-Ring	Joint torique	Junta de tipo O
25	6110006M91			1 Tube Assy	Tuyauterie	Conjunto de tubería
26	6194036M91		Lockout Valve	X Kit, Seal	Pochette de joints	Juego de juntas



820 860 970
 TX760B TX860B

801 802 803 804 805 806 807 808 813 814 817 821 822 825 921 922

98057C04.1

6199042M3

1

Jan-06

Hose Burst Kit
Coffret de Éclatement de Tuyau
Juego de rotura de tubo flexible

Loader Arm Cylinder
Vérin de Bras Chargeur
Gato de brazo cargador

4.9m
 4.9m
 4.9m

C-98058-01.1-A

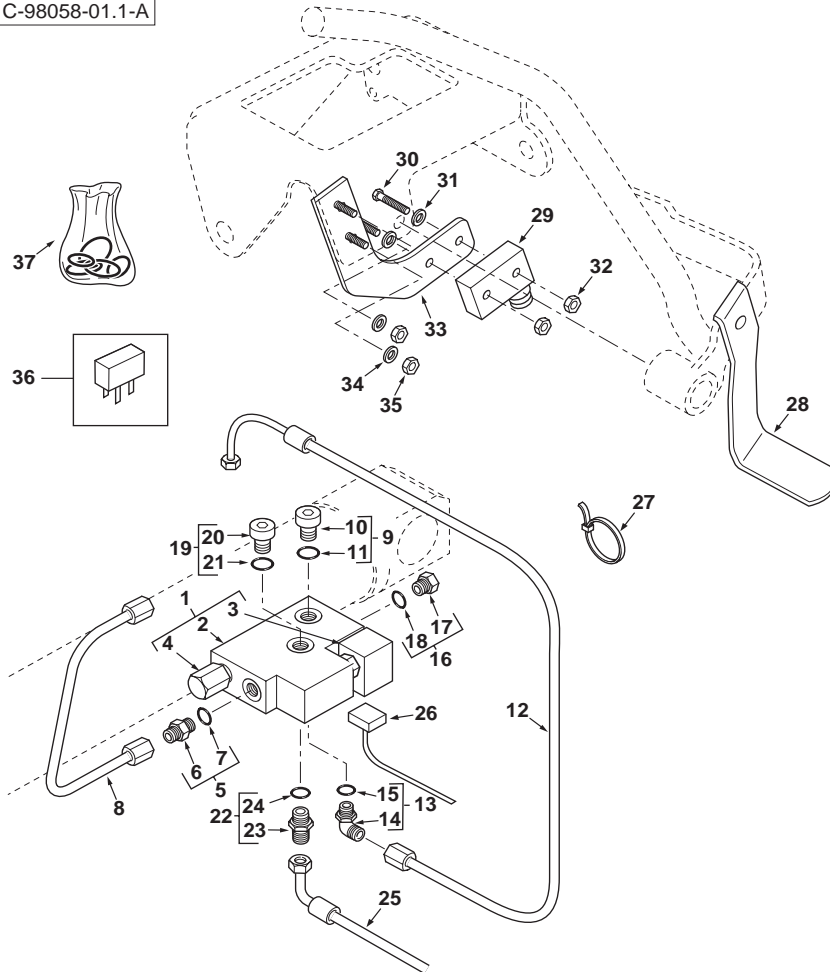

1	6109880M91		2	Valve, Lockout	Soupape verrouillage	Válvula de bloqueo.
2		1 (A) ➔ Ref. 1	1	Valve	Soupape	Válvula
3	6193308M91	1 (A) Solenoid	1	Cartridge	Cartouche	Cartucho
4	6193173M91	1 (A) Solenoid	1	Coil Assy	Ensemble de bobine	Bobina, Conj.
5	835013M91		2	Connector Assy	Ensemble connexion	Conexión, Conj.
6		5 ➔ Ref. 5	1	Connector	Connecteur	Conector
7	835024M1	5	1	O-Ring	Joint torique	Junta de tipo O
8	6109936M91	◀	1	Tube Assy	Tuyauterie	Conjunto de tubería
8	6109938M91	▶	1	Tube Assy	Tuyauterie	Conjunto de tubería
9	373772M91	9/16	2	Plug Assy	Ensemble bouchons	Tapón, Conj.
10		9 ➔ Ref. 9	1	Plug	Bouchon	Tapón
11	831452M1	9	1	O-Ring	Joint torique	Junta de tipo O
12	6109922M91		2	Hose Assy	Ensemble de flexible	Flexible, Conj.
13	357197X91		2	Elbow, 90°	Coude à 90°	Codo, 90°
14		10 ➔ Ref. 10	1	Elbow	Coude	Codo
15	831452M1	10	1	O-Ring	Joint torique	Junta de tipo O
16	6109935M91	7/8"	2	Connector Assy	Ensemble connexion	Conexión, Conj.
17		16 ➔ Ref. 16	1	Connector	Connecteur	Conector
18	835024M1	16	1	O-Ring	Joint torique	Junta de tipo O
19	373772M91	9/16	2	Plug Assy	Ensemble bouchons	Tapón, Conj.
20		19 ➔ Ref. 19	1	Plug	Bouchon	Tapón
21	831452M1	19	1	O-Ring	Joint torique	Junta de tipo O
22	6109947M91	9/16"	2	Restrictor	Réduction	Reducción
23		22 ➔ Ref. 22	1	Restrictor	Réduction	Reducción
24	831452M1	22	1	O-Ring	Joint torique	Junta de tipo O
25	6109923M91		1	Hose Assy	Ensemble de flexible	Flexible, Conj.
26	6102074M91		1	Harness	Faisceau	Haz
27	1664405M1		12	Tie, Cable	Attache câble	Enlace de Cable
28	6109603M1		1	Actuator	Vérin	Mecanismo de mando
29	6102075M91		1	Switch Assy	Ensemble commutat.	Conmutador, Conj.
30	3522433M2	M3 x 35	2	Screw	Vis	Tornillo
31	390752X1		2	Washer	Rondelle	Arandela
32	391216X1	M3	2	Nut	Écrou	Tuerca
33	6109602M91	Switch	1	Plate Assy	Ensemble de plaque	Placa, Conj.
34	390469X1	M5	2	Washer	Rondelle	Arandela
35	3005823X1	M5	2	Nut	Écrou	Tuerca
36	6102490M1		1	Relay	Relais	Relé
37	6194037M91	Lockout Valve	X	Kit, Seal	Pochette de joints	Juego de juntas

A Not illustrated
 Non illustrée
 No ilustrado



860 970
 TX870B

815 816 823 824 923

98058C01.1

6199042M3

1

Jan-06

Hose Burst Kit
Coffret de Éclatement de Tuyau
Juego de rotura de tubo flexible

Loader Bucket Cylinder
Vérin de Godet Chargeur
Gato de cuchara

4.9m
 4.9m
 4.9m

C-98058-02.1-A

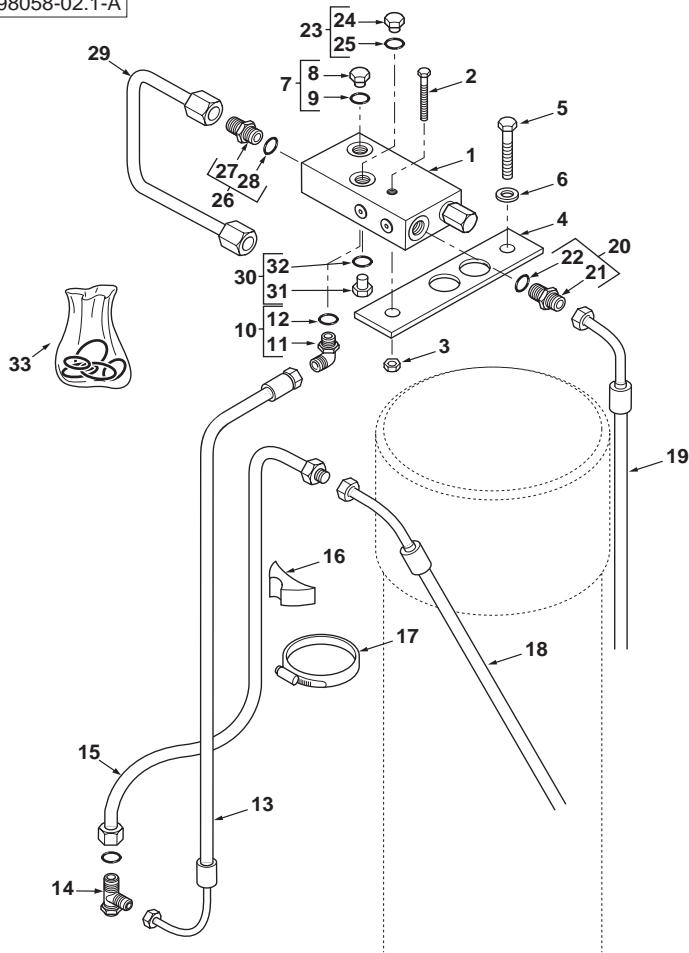

1	6109881M91		1	Valve, Lockout	Soupape verrouillage	Válvula de bloqueo.
2	339368X1	M8 x 60	2	Bolt, Lockout	Boulon	Perno
3	394367X1	M8	2	Nut, Lock	Écrou de blocage	Tuerca de retención
4	6109958M1		1	Plate	Plaque	Placa
5	3009505X1	M12 x 25	2	Bolt	Boulon	Perno
6	390735X1	M12	2	Washer	Rondelle	Arandela
7	373772M91	9/16	1	Plug Assy	Ensemble bouchons	Tapón, Conj.
8		8	1	Plug	Bouchon	Tapón
9	831452M1	8	1	O-Ring	Joint torique	Junta de tipo O
10	358781X91		1	Elbow, 45°	Coude à 45°	Codo, 45°
11		10	1	Elbow	Coude	Codo
12	831452M1	10	1	O-Ring	Joint torique	Junta de tipo O
13	6102015M91		1	Hose Assy	Ensemble de flexible	Flexible, Conj.
14	6102014M91		1	Tee	Raccord en T	Te
15	6106232M91		1	Tube Assy	Tuyauterie	Conjunto de tubería
16	L79937		1	Spacer	Entretoise	Traviesa
17	3517734M1		1	Clamp	Collier de serrage	Argolla de cierre
18	6102383M91		1	Hose Assy	Ensemble de flexible	Flexible, Conj.
19	6106233M92		1	Hose Assy	Ensemble de flexible	Flexible, Conj.
20	835013M91		1	Connector Assy	Ensemble connexion	Conexión, Conj.
21		20	1	Connector	Connecteur	Conector
22	835024M1	20	1	O-Ring	Joint torique	Junta de tipo O
23	373772M91	9/16	1	Plug Assy	Ensemble bouchons	Tapón, Conj.
24		23	1	Plug	Bouchon	Tapón
25	831452M1	23	1	O-Ring	Joint torique	Junta de tipo O
26	835013M91		1	Connector Assy	Ensemble connexion	Conexión, Conj.
27		26	1	Connector	Connecteur	Conector
28	835024M1	26	1	O-Ring	Joint torique	Junta de tipo O
29	6109956M91		1	Tube Assy	Tuyauterie	Conjunto de tubería
30	373772M91	9/16	1	Plug Assy	Ensemble bouchons	Tapón, Conj.
31		30	1	Plug	Bouchon	Tapón
32	831452M1	30	1	O-Ring	Joint torique	Junta de tipo O
33	6194038M91	Lockout Valve	X	Kit, Seal	Pochette de joints	Juego de juntas



860 970
 TX870B

815 816 823 824 923

98058C02.1

6199042M3

1

Jan-06

Hose Burst Kit
Coffret de Éclatement de Tuyau
Juego de rotura de tubo flexible

Boom Cylinder
 Vérin de Flèche
 Gato de pluma

4.9m
 4.9m
 4.9m

C-98058-03.1-A

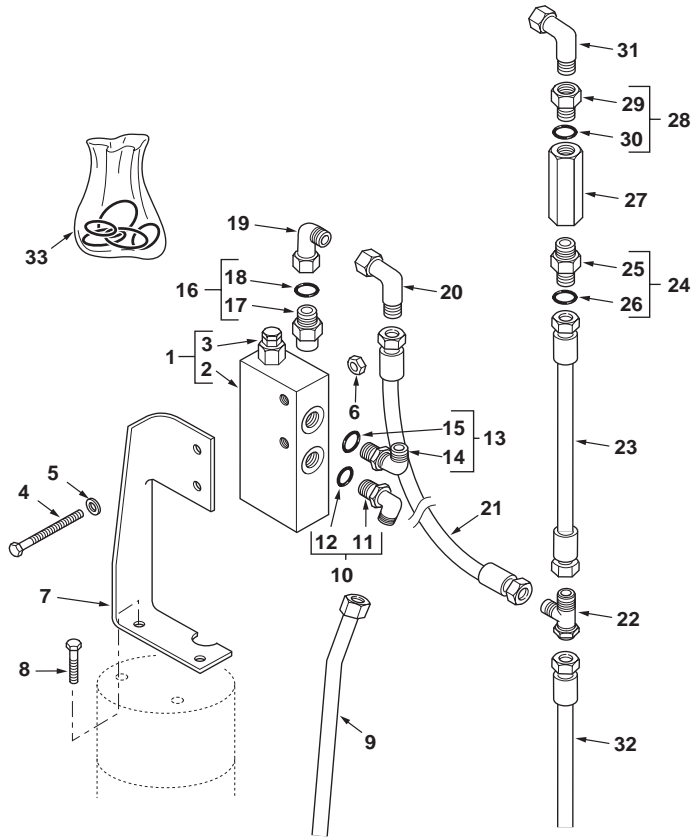

1	6109649M91		1	Valve, Lockout	Soupape verrouillage	Válvula de bloqueo.
2		1	➡ Ref. 1	1	Valve	Soupape
3	6194035M91	1	Bypass Relief	1	Cartridge Assy	Ensemble de cartouche
4	339368X1		M8 x 60	1	Bolt	Boulon
5	385361X1		M8	1	Washer	Rondelle
6	394367X1		M8	1	Nut, Lock	Écrou de blocage
7	6101960M1			1	Bracket	Patte de fixation
8	339123X1		M8 x 20	2	Bolt	Boulon
9	6102472M91			1	Tube Assy	Tuyauterie
10	835007M91			1	Elbow, 90°	Coude à 90°
11		10	➡ Ref. 10	1	Elbow	Coude
12	835024M1	10		1	O-Ring	Joint torique
13	835007M91			1	Elbow, 90°	Coude à 90°
14		13	➡ Ref. 13	1	Elbow	Coude
15	835024M1	13		1	O-Ring	Joint torique
16	835091M91		9/16	1	Union	Union
17		16	➡ Ref. 16	1	Connector	Connecteur
18	831452M1	16		1	O-Ring	Joint torique
19	364603X1		9/16	1	Elbow, 90°	Coude à 90°
20	364603X1		9/16	1	Elbow, 90°	Coude à 90°
21	6110438M91			1	Hose Assy	Ensemble de flexible
22	6102014M91			1	Tee	Raccord en T
23	6110437M91			1	Hose Assy	Ensemble de flexible
24	365715X91		1,1/16" - 7/8" UNF	1	Connector Assy	Ensemble connexion
25		24	➡ Ref. 24	1	Connector	Connecteur
26	835025M1	24		1	O-Ring	Joint torique
27	6109877M91			1	Valve, Check	Clapet anti-retour
28	6109944M91		1,1/16" - 7/8"	1	Connector Assy	Ensemble connexion
29		28	➡ Ref. 28	1	Connector	Connecteur
30		28	➡ Ref. 28	1	O-Ring	Joint torique
31	367386X1			1	Elbow, 90°	Coude à 90°
32	6101966M91			1	Hose Assy	Ensemble de flexible
33	6194034M91		Lockout Valve	1	Kit, Seal	Pochette de joints



860 970
 TX870B

815 816 823 824 923

98058C03.1

6199042M3

1

Jan-06

Hose Burst Kit
Coffret de Éclatement de Tuyau
Juego de rotura de tubo flexible

Dipper Cylinder
 Vérin de Balancier
 Gato de balancín

4.9m
 4.9m
 4.9m

C-98058-04.1-A

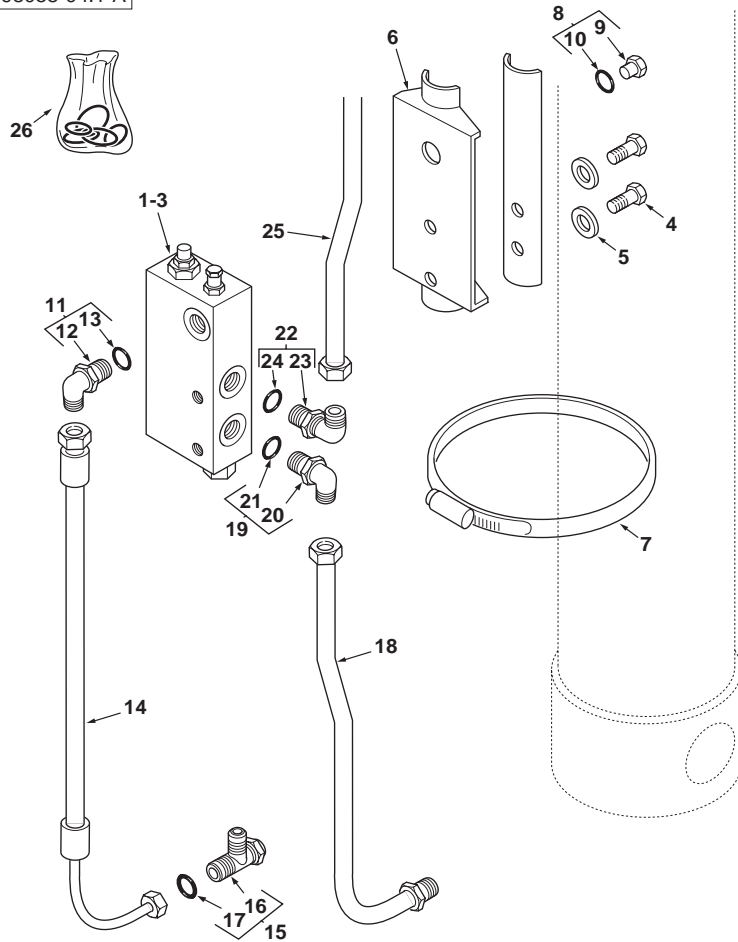

1	6109882M91		1	Valve, Lockout	Soupape verrouillage	Válvula de bloqueo.
2		1	▶ Ref. 1	1 Valve	Soupape	Válvula
3	6194035M91	1	Bypass Relief	1 Cartridge Assy	Ensemble de cartouche	Cartucho, Conj.
4	3009491X1		M10 x 20	2 Screw	Vis	Tornillo
5	390734X1		M10	2 Washer	Rondelle	Arandela
6	6110008M91			1 Bracket Assy	Ensemble chaise palier	Cuchara, Conj.
7	3517731M1			2 Clip, Mounting	Collier de fixation	Argolla de fijación
8	373772M91		9/16	1 Plug Assy	Ensemble bouchons	Tapón, Conj.
9		9	▶ Ref. 9	1 Plug	Bouchon	Tapón
10	831452M1		9	1 O-Ring	Joint torique	Junta de tipo O
11	357197X91			1 Elbow, 90°	Coude à 90°	Codo, 90°
12		11	▶ Ref. 11	1 Elbow	Coude	Codo
13	831452M1		11	1 O-Ring	Joint torique	Junta de tipo O
14	6101955M91			1 Hose Assy	Ensemble de flexible	Flexible, Conj.
15	6101954M91			1 Tee	Raccord en T	Te
16		15	▶ Ref. 15	1 Tee	Raccord en T	Te
17	835024M1		15	1 O-Ring	Joint torique	Junta de tipo O
18	6110004M91			1 Tube Assy	Tuyauterie	Conjunto de tubería
19	835007M91			1 Elbow, 90°	Coude à 90°	Codo, 90°
20		19	▶ Ref. 19	1 Elbow	Coude	Codo
21	835024M1		19	1 O-Ring	Joint torique	Junta de tipo O
22	6101624M91			1 Elbow, 90°	Coude à 90°	Codo, 90°
23				1 Elbow	Coude	Codo
24	835024M1			1 O-Ring	Joint torique	Junta de tipo O
25	6110006M91			1 Tube Assy	Tuyauterie	Conjunto de tubería
26	6194036M91		Lockout Valve	X Kit, Seal	Pochette de joints	Juego de juntas



860 970
 TX870B

815 816 823 824 923

98058C04.1

6199042M3

1

Jan-06

JCB Bucket Pins Kit
Coffret de Attaches de Godet JCB
Juego de pasadores cuchara JCB

Single
 Simple
 Simple

C-98008-01.1-A

1	6106549M1	45 x 364 mm	2	Pin	Axe	Pasador
2	375096X1		4	Pin, Linch	Goupille d'arrêt	Pasador de parada
3	3501790M1		4	Washer	Rondelle	Arandela

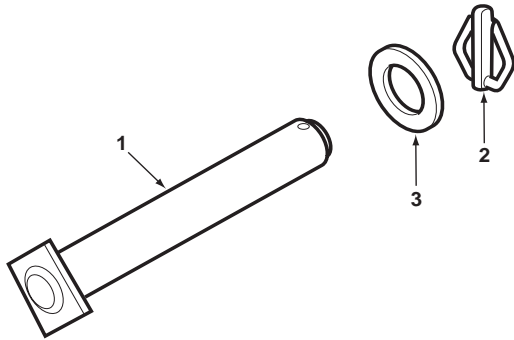

820 860 880 970 980
 TX760B TX860B
 TX870B TX970B

801 802 803 804 805 806 807 808 813 814 815 816 817 821 822 823 824 825 831
 832 833 834 841 842 843 844 845 851 852 853 854 855 921 922 923 931 932

JCB Bucket Pins Kit
 Coffret de Attaches de Godet JCB
 Juego de pasadores cuchara JCB

Double
 Double
 Doble

C-98009-01.1-A

1	6106549M1	45 x 364 mm	4	Pin	Axe	Pasador
2	375096X1		8	Pin, Linch	Goupille d'arrêt	Pasador de parada
3	3501790M1		8	Washer	Rondelle	Arandela

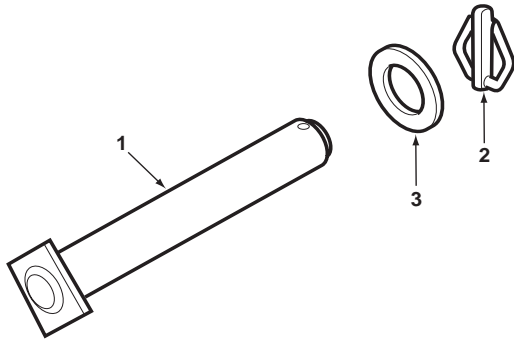

820 860 880 970 980
 TX760B TX860B
 TX870B TX970B

801 802 803 804 805 806 807 808 813 814 815 816 817 821 822 823 824 825 831
 832 833 834 841 842 843 844 845 851 852 853 854 855 921 922 923 931 932

98009C01.1

6199042M3

1

Jan-06

Kit
Coffret
Juego

Boom Guard

C-98186-01.1-A

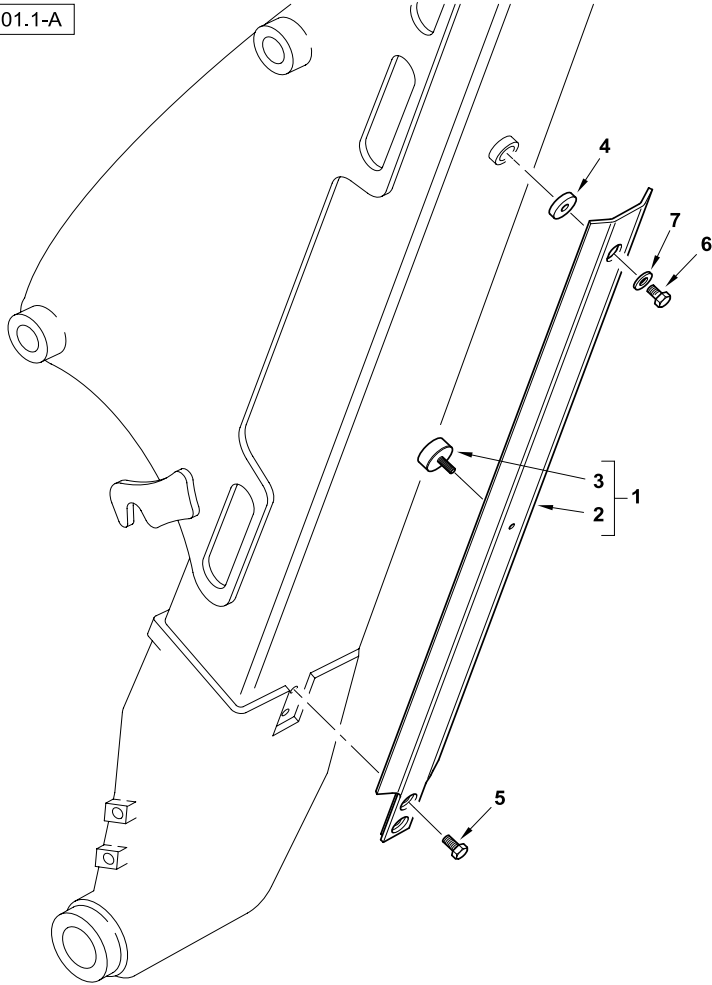

1	6110712M91			1	Guard Assy	Ensemble protection	Protector, Conj.
2		1	Ref. 1	1	Guard	Protecteur	Protector
3	6110763M1	1		1	Mount, Rubber	Support caoutchouc	Bloque de caucho
4	6110843M1			1	Washer	Rondelle	Arandela
5	3009505X1	M12 x 25		2	Bolt	Boulon	Perno
6	339299X1	M12 x 30		1	Screw	Vis	Tornillo
7	385363X1	M12		1	Washer	Rondelle	Arandela



880 980
TX760B TX860B
TX870B TX970B

831 832 833 834 841 842 843 844 845 851 852 853 854 855 931 932

98186C01.1

6199042M3

1

Jan-06

Kit
Coffret
Juego

Engine Breather
Reniflard
Respiradero

C-98037-01.1-A

1	6110421M1		1	Bracket	Patte de fixation	Pata de fijación
2	3009505X1	M12 x 25	3	Bolt	Boulon	Perno
3	390735X1	M12	3	Washer	Rondelle	Arandela
4	6110424M91	(A)	1	Breather Assy	Ensemble de reniflard	Ventil. cárter, Conj.

A Details to be advised
Détails à demander
Detalles que deben ser notificados

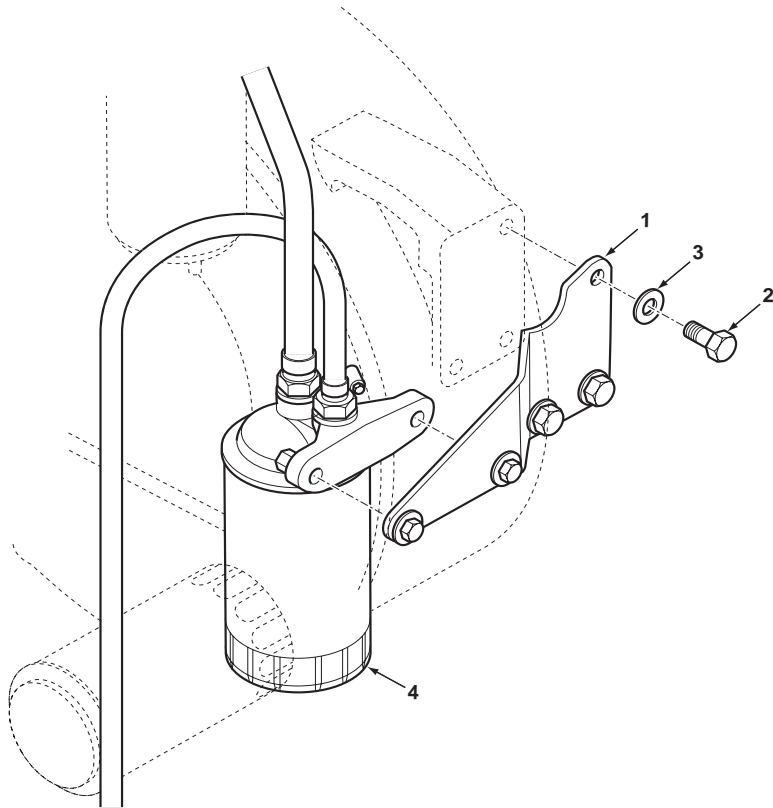

860
TX860B

813 821

98037C01.1

6199042M3

1

Jan-06

Kit
Coffret
Juego

Filter
Filtre
Filtro

Powershift
Powershift
Powershift

C-98111-01.1-A

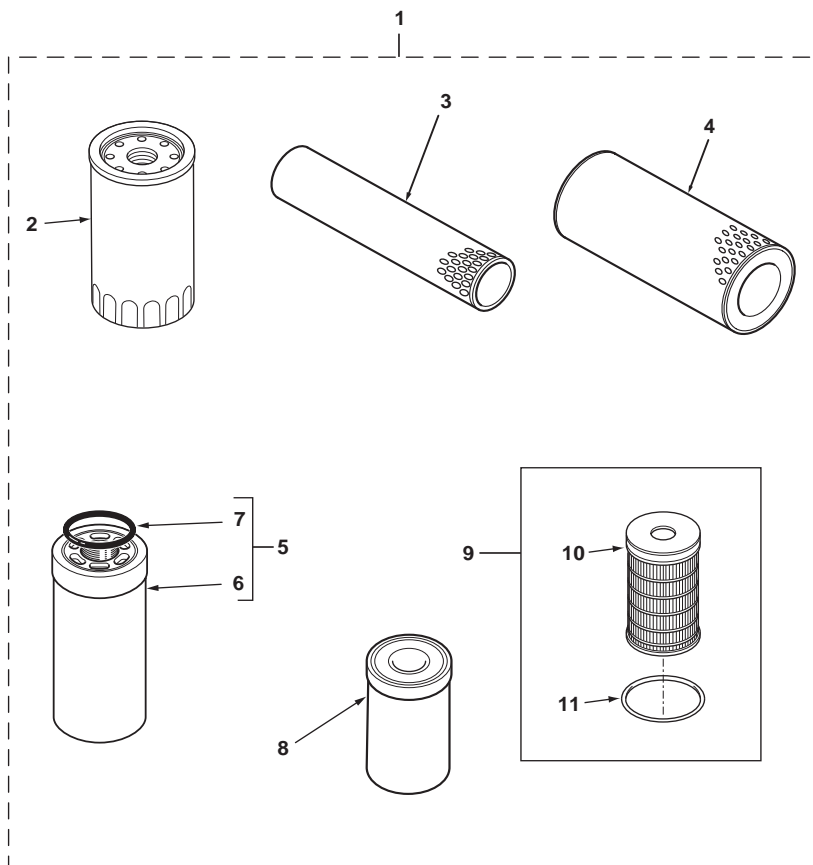

1	6110289M91			1	Kit - Filter	Coffret - Filtre	Juego - Filtro
2	2654407	1	Engine	1	Filter, Oil	Filtre à huile	Filtro de aceite
3	6190628M1	1	Air Safety	1	Element, Filter	Élément filtrant	Elemento filtrante
4	6190627M1	1	Air Main	1	Element, Filter	Élément filtrant	Elemento filtrante
5	6100361M91	1	Main Hydraulics	1	Element, Filter	Élément filtrant	Elemento filtrante
6		5	➡ Ref. 5	1	Element, Filter	Élément filtrant	Elemento filtrante
7		5	➡ Ref. 5	1	O-Ring	Joint torique	Junta de tipo O
8	6194045M91	1	Transmission	1	Element, Filter	Élément filtrant	Elemento filtrante
9	26560201	1	Fuel	1	Element, Filter	Élément filtrant	Elemento filtrante
10		9	➡ Ref. 9	1	Element	Élément	Elemento
11		9 (A)		1	Ring, Sealing	Bague d'étanchéité	Anillo, Estanqueidad

A Part number to be advised
Référence pièce à demander
Indicar número de pieza



860 880 970 980
TX860B TX870B
TX970B

821 822 823 824 825 851 852 853 854 855 921 922 923 931 932

98111C01.1

6199042M3

1

Jan-06

Kit
Coffret
Juego

Filter
Filtre
Filtro

Synchro Shuttle - Turner
Synchro Shuttle - Turner
Synchro Shuttle - Turner

C-98112-01.1-A

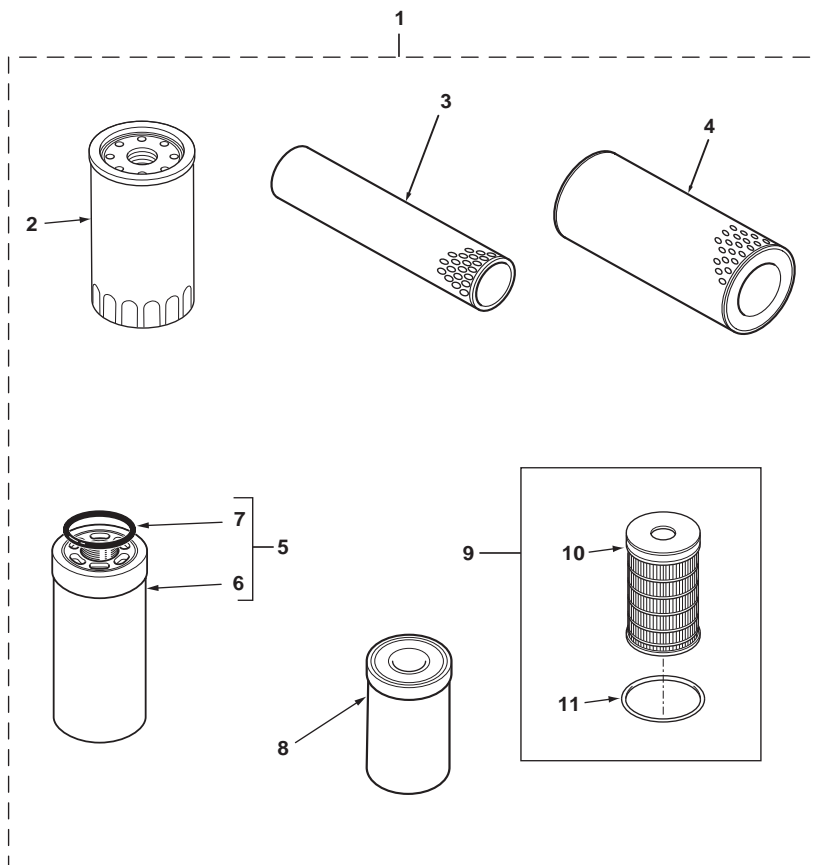

1	6110292M91			1	Kit - Filter	Coffret - Filtre	Juego - Filtro
2	2654407	1	Engine	1	Filter, Oil	Filtre à huile	Filtro de aceite
3	6190628M1	1	Air Safety	1	Element, Filter	Élément filtrant	Elemento filtrante
4	6190627M1	1	Air Main	1	Element, Filter	Élément filtrant	Elemento filtrante
5	6100361M91	1	Main Hydraulics	1	Element, Filter	Élément filtrant	Elemento filtrante
6		5	➡ Ref. 5	1	Element, Filter	Élément filtrant	Elemento filtrante
7		5	➡ Ref. 5	1	O-Ring	Joint torique	Junta de tipo O
8	6190810M1	1	Transmission	1	Filter, Oil	Filtre à huile	Filtro de aceite
9	26560201	1	Fuel	1	Element, Filter	Élément filtrant	Elemento filtrante
10		9	➡ Ref. 9	1	Element	Élément	Elemento
11		9 (A)		1	Ring, Sealing	Bague d'étanchéité	Anillo, Estanqueidad

A Part number to be advised
Référence pièce à demander
Indicar número de pieza



820 860 880
TX760B TX860B
TX870B

801 802 803 804 805 806 807 808 809 810 811 812 813 814 815 816 817 823 831
832 833 834 841 842 843 844 845

98112C01.1

6199042M3

1

Jan-06

Kit
Coffret
Juego

Filter
Filtre
Filtro

Synchro Shuttle - Carraro
Synchro Shuttle - Carraro
Synchro Shuttle - Carraro

C-98193-01.1-A

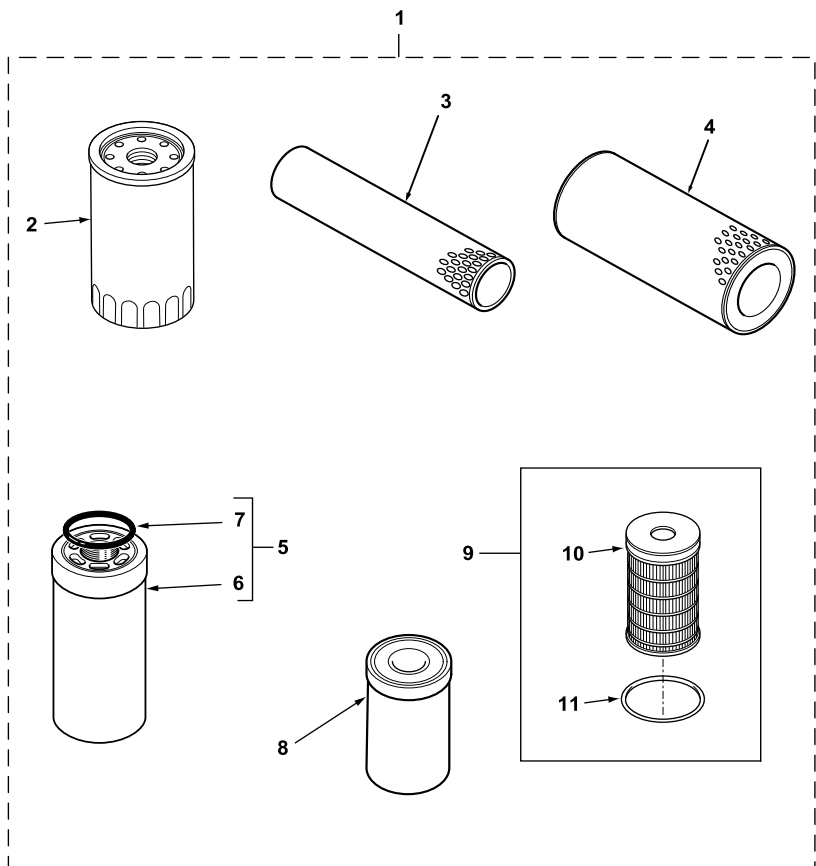

1	6110699M91			1	Kit - Filter	Coffret - Filtre	Juego - Filtro
2	2654407	1	Engine	1	Filter, Oil	Filtre à huile	Filtro de aceite
3	6190628M1	1	Air Safety	1	Element, Filter	Élément filtrant	Elemento filtrante
4	6190627M1	1	Air Main	1	Element, Filter	Élément filtrant	Elemento filtrante
5	6100361M91	1	Main Hydraulics	1	Element, Filter	Élément filtrant	Elemento filtrante
6		5	➡ Ref. 5	1	Element, Filter	Élément filtrant	Elemento filtrante
7		5	➡ Ref. 5	1	O-Ring	Joint torique	Junta de tipo O
8	6110604M91	1	Transmission	1	Filter, Oil	Filtre à huile	Filtro de aceite
9	26560201	1	Fuel	1	Element, Filter	Élément filtrant	Elemento filtrante
10		9	➡ Ref. 9	1	Element	Élément	Elemento
11		9 (A)		1	Ring, Sealing	Bague d'étanchéité	Anillo, Estanqueidad

A Part number to be advised
Référence pièce à demander
Indicar número de pieza



820 860
TX760B TX860B
TX870B

803 804 807 808 813 814 815 816 817 831 832 833 834

98193C01.1

6199042M3

1

Jan-06

Kit
Coffret
Juego

Forks
Fourchettes
Horquillas

Loader Bucket
Godet Chargeur
Cuchara cargadora

1.0 Cubic metre
1.0 Cubic metre
1.0 Cubic metre

AC-94001-01.1-A

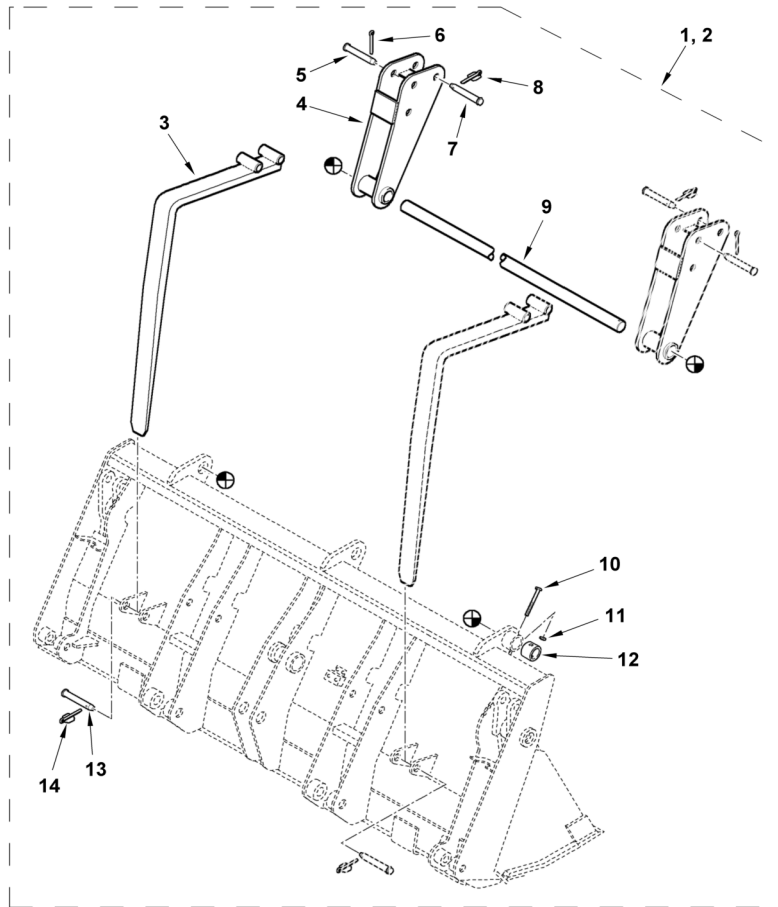

1	ACC21A		Fork Kit 1cm	1	Accessory code	Code accessoire	Código accesorio
2	6106224M94	1		1	Kit, Fork	Jeu de fourchettes	Juego de horquillas
3	3519728M91	2		2	Fork Assy	Ensemble de fourche	Horquilla, Conj.
4	6103661M92	2		2	Pivot Assy	Ensemble de pivot	Pivote, Conj.
5	3507537M1	2	25 x 157 mm	2	Pin	Axe	Pasador
6	1442984X1	2		2	Pin, Split	Goupille	Pasador
7	3507537M1	2	25 x 157 mm	1	Pin	Axe	Pasador
8	810285M92	2		2	Pin, Linch	Goupille d'arrêt	Pasador de parada
9	6103667M1	2		1	Bar	Barre	Barra
10	3009503X1	2	M10 x 90	2	Screw	Vis	Tornillo
11	1441932X1	2	M10	2	Nut	Écrou	Tuerca
12	6103668M1	2		2	Boss	Bossage	Saliente
13	3507537M1	2	25 x 157 mm	2	Pin	Axe	Pasador
14	810285M92	2		2	Pin, Linch	Goupille d'arrêt	Pasador de parada



820 860 880
TX760B TX860B
TX870B

801 802 803 804 805 806 807 808 809 810 811 812 813 814 815 816 817 821 822
823 824 825 831 832 833 834 841 842 843 844 845 851 852 853 854 855

94001AC01.1

6199042M3

1

Jan-06

Kit
Coffret
Juego

Forks
Fourchettes
Horquillas

Loader Bucket
Godet Chargeur
Cuchara cargadora

1.0 Cubic metre
1.0 Cubic metre
1.0 Cubic metre

C-94001-01.1-A

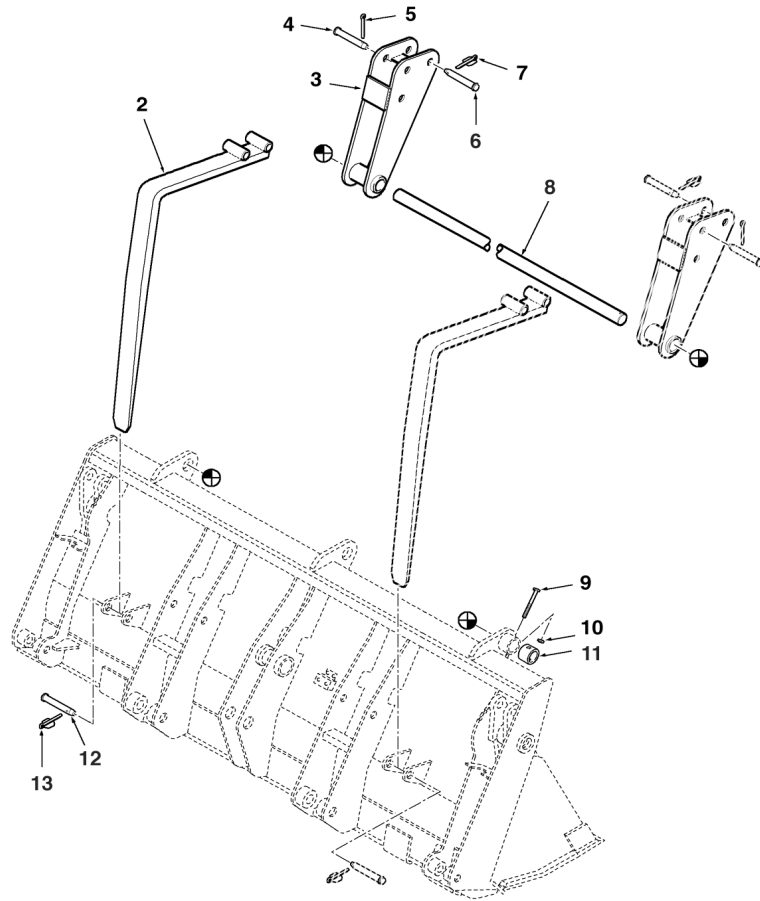

1	6106224M94			1	Kit, Fork	Jeu de fourchettes	Juego de horquillas
2	3519728M91	1		2	Fork Assy	Ensemble de fourche	Horquilla, Conj.
3	6103661M92	1		2	Pivot Assy	Ensemble de pivot	Pivote, Conj.
4	3507537M1	1	25 x 157 mm	2	Pin	Axe	Pasador
5	1442984X1	1		2	Pin, Split	Goupille	Pasador
6	3507537M1	1	25 x 157 mm	1	Pin	Axe	Pasador
7	810285M92	1		2	Pin, Linch	Goupille d'arrêt	Pasador de parada
8	6103667M1	1		1	Bar	Barre	Barra
9	3009503X1	1	M10 x 90	2	Screw	Vis	Tornillo
10	1441932X1	1	M10	2	Nut	Écrou	Tuerca
11	6103668M1	1		2	Boss	Bossage	Saliente
12	3507537M1	1	25 x 157 mm	2	Pin	Axe	Pasador
13	810285M92	1		2	Pin, Linch	Goupille d'arrêt	Pasador de parada



820 860 880
TX760B TX860B
TX870B

801 802 803 804 805 806 807 808 809 810 811 812 813 814 815 816 817 821 822
823 824 825 831 832 833 834 841 842 843 844 845 851 852 853 854 855

94001C01.1

6199042M3

1

Jan-06

Kit
Coffret
Juego

Forks
Fourchettes
Horquillas

Loader Bucket
Godet Chargeur
Cuchara cargadora

1.2 Cubic metre
1.2 Cubic metre
1.2 Cubic metre

C-94002-01.1-A

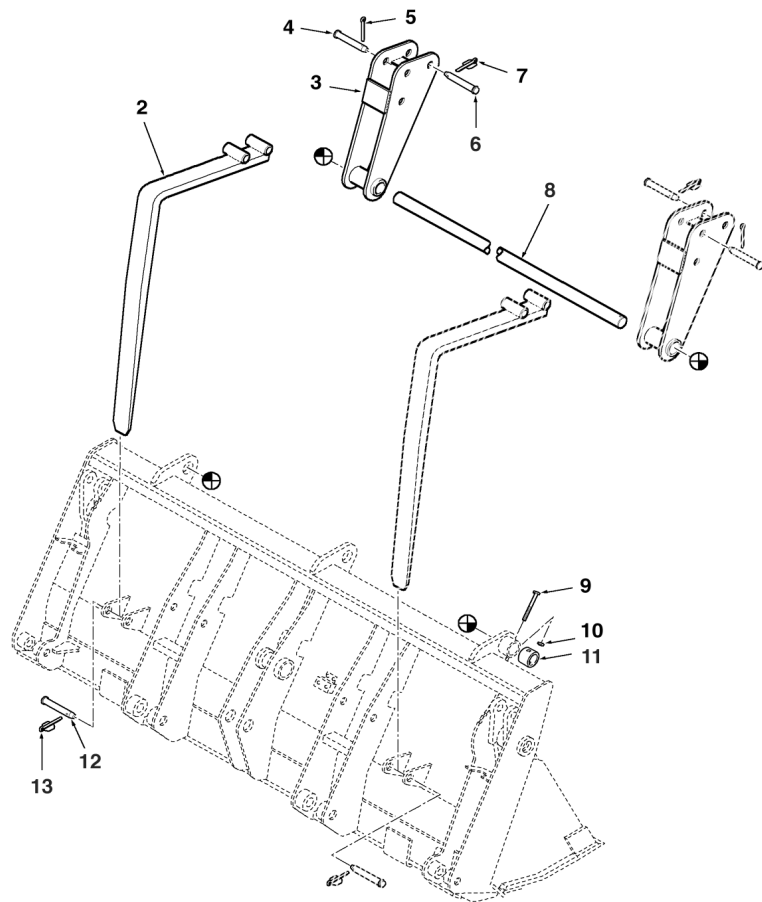

1	6106254M94			1	Kit, Fork	Jeu de fourchettes	Juego de horquillas
2	3516339M91	1		2	Fork Assy	Ensemble de fourche	Horquilla, Conj.
3	6103661M92	1		2	Pivot Assy	Ensemble de pivot	Pivote, Conj.
4	3507537M1	1	25 x 157 mm	2	Pin	Axe	Pasador
5	1442984X1	1		2	Pin, Split	Goupille	Pasador
6	3507537M1	1	25 x 157 mm	2	Pin	Axe	Pasador
7	810285M92	1		2	Pin, Linch	Goupille d'arrêt	Pasador de parada
8	6103667M1	1		1	Bar	Barre	Barra
9	3009503X1	1	M10 x 90	2	Screw	Vis	Tornillo
10	1441932X1	1	M10	2	Nut	Écrou	Tuerca
11	6103668M1	1		2	Boss	Bossage	Saliente
12	3507537M1	1	25 x 157 mm	2	Pin	Axe	Pasador
13	810285M92	1		2	Pin, Linch	Goupille d'arrêt	Pasador de parada



860 880 970 980
TX860B TX870B
TX970B

809 810 811 812 813 814 815 816 817 821 822 823 824 825 841 842 843 844 845
851 852 853 854 855 921 922 923 931 932

94002C01.1

6199042M3

1

Jan-06

Kit
Coffret
Juego

Front Grille Protection
Protecteur
Protector

C-98188-01.1-A

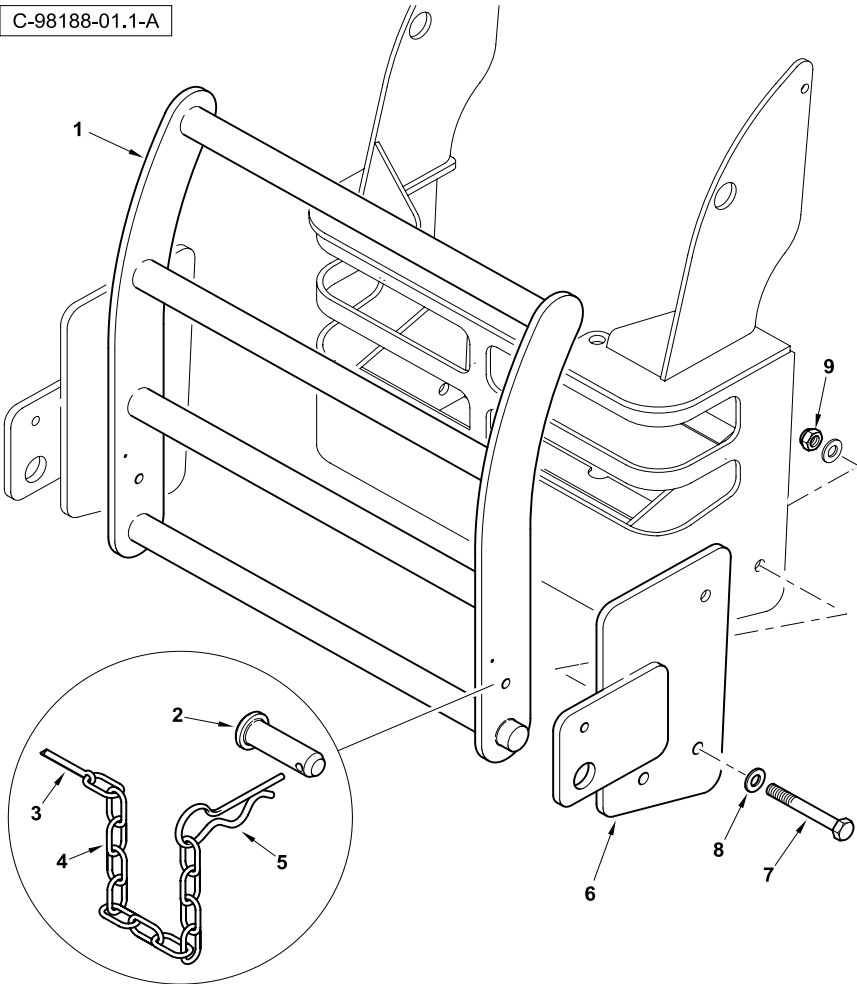

1	6110576M91		1	Guard Assy	Ensemble protection	Protector, Conj.
2	3019214X1	12 x 40mm	1	Pin, Headed	Axe à tête	Pasador con cabeza
3	1442994X1		1	Pin, Split	Goupille	Pasador
4	3517165M1		1	Chain	Chaîne	Cadena
5	377165X1		1	Pin, Linch	Goupille d'arrêt	Pasador de parada
6	6110577M1	LH	1	Plate Assy	Ensemble de plaque	Placa, Conj.
6	6110578M1	RH	1	Plate Assy	Ensemble de plaque	Placa, Conj.
7	6007823M1	M16 x 130	4	Bolt	Boulon	Perno
8	1441664X1		8	Washer	Rondelle	Arandela
9	1442739X1		4	Nut	Écrou	Tuerca



880 980
TX760B TX860B
TX870B TX970B

831 832 833 834 841 842 843 844 845 851 852 853 854 855 931 932

98188C01.1

6199042M3

1

Jan-06

Kit
Coffret
Juego

Headrest
Repose Tete
Apoya Cabeza

AC-98107-01.1-A

1	ACC06A			1	Accessory code	Code accessoire	Código accesorio
2	6108913M1	1		1	Headrest	Repose tete	Apoya Cabeza

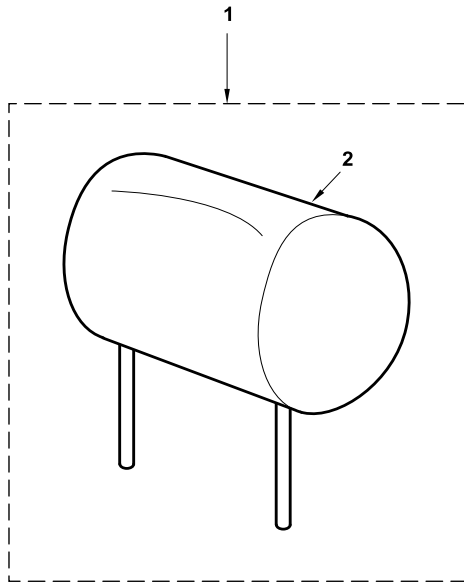

820 860 880 970 980
TX760B TX860B
TX870B TX970B

801 802 803 804 805 806 807 808 809 810 811 812 813 814 815 816 817 821 822
823 824 825 831 832 833 834 841 842 843 844 845 851 852 853 854 855 921 922
923 931 932

98107AC01.1

6199042M3

1

Jan-06

Kit
Coffret
Juego

Headrest
Repose Tete
Apoya Cabeza

C-98107-01.1-A

1	6108913M1		1	Headrest	Repose tete	Apoya Cabeza
---	-----------	--	---	----------	-------------	--------------

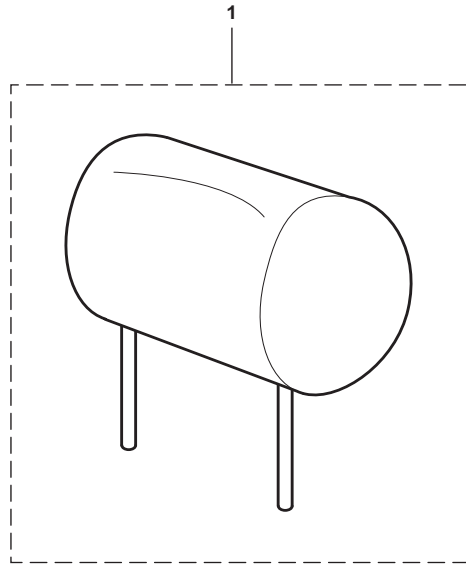

820 860 880 970 980
TX760B TX860B
TX870B TX970B

801 802 803 804 805 806 807 808 809 810 811 812 813 814 815 816 817 821 822
823 824 825 831 832 833 834 841 842 843 844 845 851 852 853 854 855 921 922
923 931 932

98107C01.1

6199042M3

1

Jan-06

Kit
Coffret
Juego

Hydraulic Pipe Guard

C-98184-01.1-A

1	6110717M91			1	Kit, Guard	Coffret, Garde	Juego, Defensa
2	6110602M91	1		1	Guard Assy	Ensemble protection	Protector, Conj.
3	3009491X1	1	M10 x 20	4	Screw	Vis	Tornillo
4	339376X1	1	M10	4	Washer, Lock	Rondelle de blocage	Arandela de freno

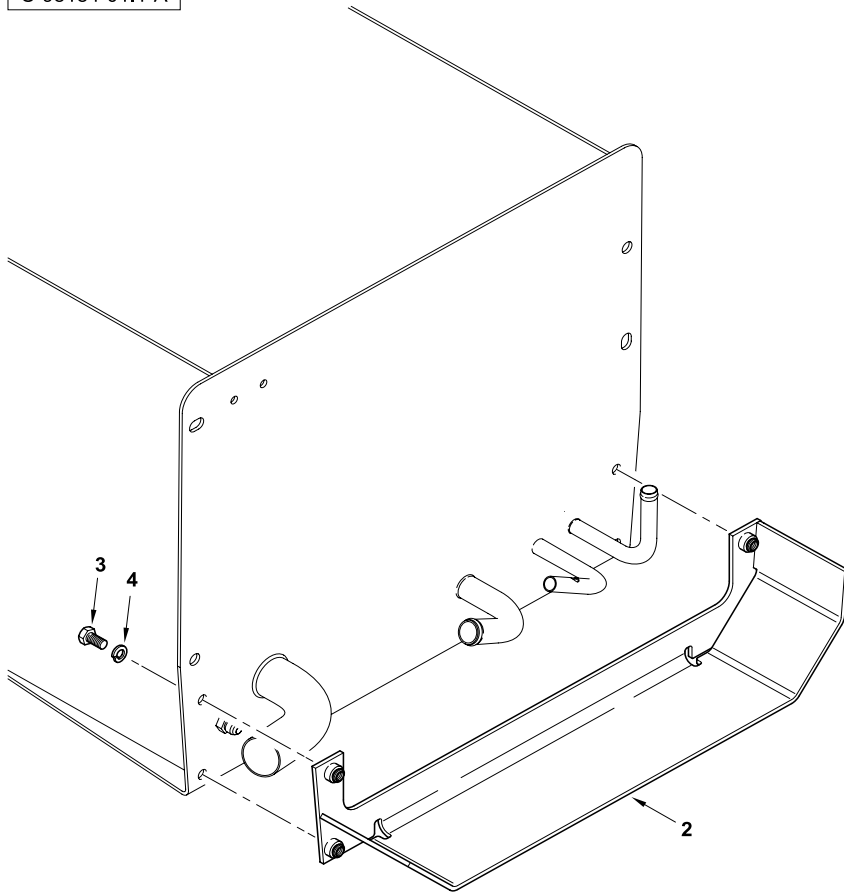

880 980
TX760B TX860B
TX870B TX970B

831 832 833 834 841 842 843 844 845 851 852 853 854 855 931 932

98184C01.1

6199042M3

1

Jan-06

Kit
Coffret
Juego

Loader Quick Attach
Attache Rapide Pour Chargeur
Acoplamiento rápido cargadora

C-94005-01.1-A

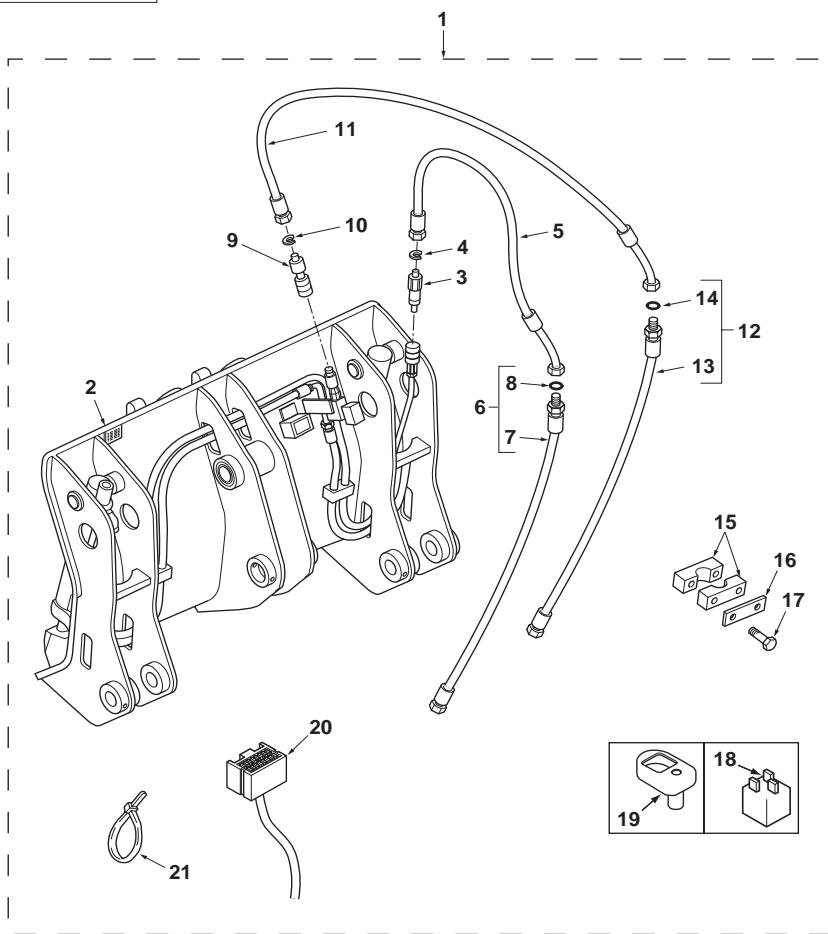

1	6101884M93			1	Kit, Parts	Lot de pièces	Juego de piezas
2	6101684M92	1	94005C02.1 1	1	Hitch Assy, Quick	Ensem. D'attel. Rapide	Engan. rápido, Conj.
3	6009429M91	1	Male	1	Coupling	Accouplement	Acoplamiento
4	6009715M1	1		1	Ring, Retaining	Anneau de retenue	Anillo de retención
5	6100351M91	1		1	Hose Assy	Ensemble de flexible	Flexible, Conj.
6	6101549M92	1	950 mm	1	Hose	Flexible	Tubo flexible
7		6	Ref. 6	1	Hose	Flexible	Tubo flexible
8	1442477X1	6		1	O-Ring	Joint torique	Junta de tipo O
9	6009430M91	1	Female	1	Coupling	Accouplement	Acoplamiento
10	6009715M1	1		1	Ring, Retaining	Anneau de retenue	Anillo de retención
11	6100351M91	1		1	Hose Assy	Ensemble de flexible	Flexible, Conj.
12	6101549M92	1	950 mm	1	Hose	Flexible	Tubo flexible
13		12	Ref. 12	1	Hose	Flexible	Tubo flexible
14	1442477X1	12		1	O-Ring	Joint torique	Junta de tipo O
15	1462584M1	1		4	Clamp	Collier de serrage	Argolla de cierre
16	1462583M1	1		2	Plate	Plaque	Placa
17	339096X1	1	M6 x 35	4	Screw	Vis	Tornillo
18	6102490M1	1	Position RL31	1	Relay	Relais	Relé
19	6101777M91	1		1	Cover	Cache	Tapa
20	3519951M91	1		1	Harness	Faisceau	Haz
21	1862425M1	1		12	Tie, Cable	Attache câble	Enlace de Cable



820 860 880 970 980
TX760B TX860B
TX870B TX970B

801 802 803 804 805 806 807 808 813 814 815 816 817 821 822 823 824 825 831
832 833 834 841 842 843 844 845 851 852 853 854 855 921 922 923 931 932

94005C01.1

6199042M3

1

Jan-06

Kit
Coffret
Juego

Loader Quick Attach Tubes
Tubes d'attache Rapide pour Chargeur
Tubos de acoplamiento rápido cargadora

C-94004-01.1-A

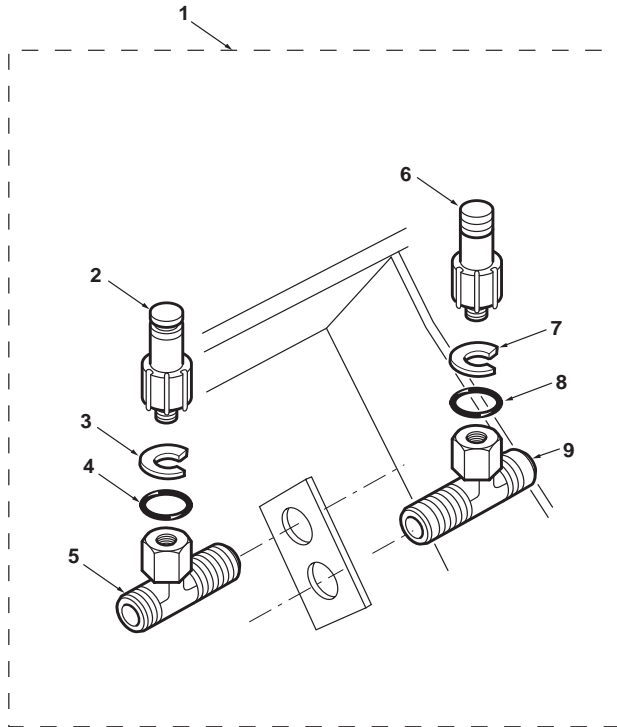

1	6106781M91			1	Kit, Parts	Lot de pièces	Juego de piezas
2	6009429M91	1	Male	1	Coupling	Accouplement	Acoplamiento
3	6009715M1	1		1	Ring, Retaining	Anneau de retenue	Anillo de retención
4	1442477X1	1		1	O-Ring	Joint torique	Junta de tipo O
5	6106782M1	1		1	Adaptor	Adaptateur	Adaptador
6	6009430M91	1	Female	1	Coupling	Accouplement	Acoplamiento
7	6009715M1	1		1	Ring, Retaining	Anneau de retenue	Anillo de retención
8	1442477X1	1		1	O-Ring	Joint torique	Junta de tipo O
9	6106782M1	1		1	Adaptor	Adaptateur	Adaptador



820 860 880 970 980
TX760B TX860B
TX870B TX970B

801 802 803 804 805 806 807 808 813 814 815 816 817 821 822 823 824 825 831
832 833 834 841 842 843 844 845 851 852 853 854 855 921 922 923 931 932

94004C01.1

6199042M3

1

Jan-06

Licence Plate
 Plaque Minéralogique
 Placa de matrícula

Rear
 Arrière
 Trasero

C-95011-01.1-A

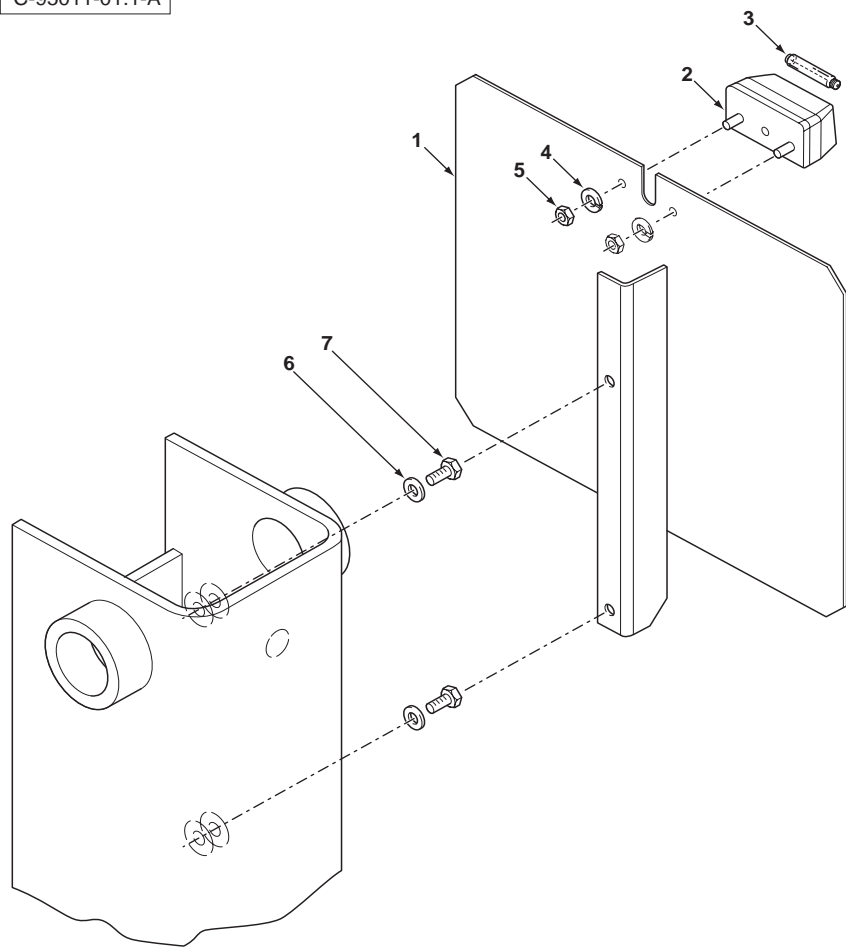

1	6106999M91			1	Plate, Licence	Plaque immatricul.	Placa de matrícula
2	3516826M91			1	Lamp Assy	Ensemble de feux	Luz, Conj.
3	3523686M1	2	12V - 5W	1	Bulb	Lampe	Lámpara
4	339381X1	2	M5	2	Washer, Lock	Rondelle de blocage	Arandela de freno
5	390995X1	2	M5	2	Nut	Écrou	Tuerca
6	339374X1		M8	2	Washer, Lock	Rondelle de blocage	Arandela de freno
7	339228X1		M8 x 12	2	Screw	Vis	Tornillo



820 860 880 970 980
 TX760B TX860B

805 806 807 808 817 825 833 834 845 855 921 931

95011C01.1



6199042M3

1

Jan-06

Pre Cleaner Kit
Coffret de Filtre à Air
Juego de filtros

C-98108-01.1-A

1	6100634M91			1	Cleaner Assy	Filtre à air, montage	Filtro, Conj.
2		1	 Ref. 1	1	Cover	Cache	Tapa
3		1	 Ref. 1	1	Bowl	Cuve	Cuba
4	3517729M1	1		1	Collar	Collier	Collar

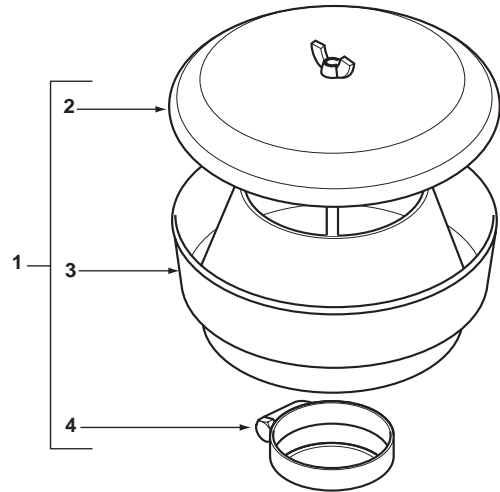

820 860 880 970 980
 TX760B TX860B
 TX870B TX970B

801 802 803 804 805 806 807 808 809 810 811 812 813 814 815 816 817 821 822
 823 824 825 831 832 833 834 841 842 843 844 845 851 852 853 854 855 921 922
 923 931 932

Quick Attach, Loader
Accouplement Rapide, Chargeur
Acoplamiento rápido, cargadora

C-94005-02.1-A

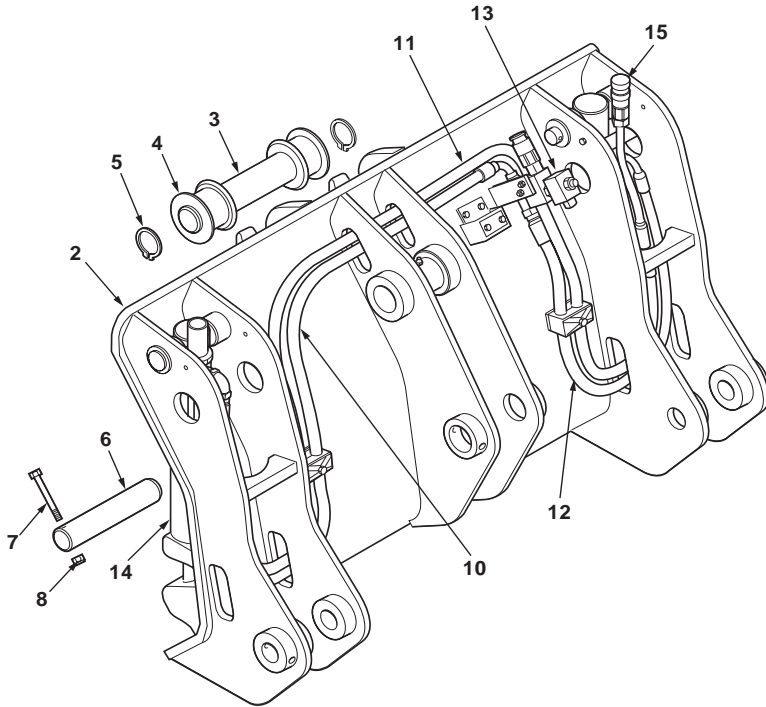

1	6101684M92		94005C01.1 2	1	Hitch Assy, Quick	Ensem. D'attel. Rapide	Engan. rápido, Conj.
2		1		1	Body	Corps	Cuerpo
3	6100158M2	1		1	Pin	Axe	Pasador
4	6100156M1	1		2	Roller	Galet	Rodillo
5	391129X1	1		2	Ring, Snap	Anneau d'arrêt	Anillo de resorte
6	3520042M5	1	40 x 212 mm	2	Pin	Axe	Pasador
7	3516014M1	1	M10 x 90	2	Screw	Vis	Tornillo
8	1440329X1	1	M10	2	Nut, Lock	Écrou de blocage	Tuerca de retención
9		1	(A)	2	Cylinder	Cylindre	Cilindro
10		1	(A)	1	Hose Assy	Ensemble de flexible	Flexible, Conj.
11		1	(A)	1	Hose Assy	Ensemble de flexible	Flexible, Conj.
12		1	(A)	1	Hose Assy	Ensemble de flexible	Flexible, Conj.
13		1	(A)	1	Solenoid	Solénoïde	Solenoid
14	6009429M91	1	Male	1	Coupling	Accouplement	Acoplamiento
15	6009430M91	1	Female	1	Coupling	Accouplement	Acoplamiento
N.I		1	(A)Seals	X	Kit, Parts	Lot de pièces	Juego de piezas

A Part number to be advised
 Référence pièce à demander
 Indicar número de pieza



820 860 880 970 980
 TX760B TX860B
 TX870B TX970B

801 802 803 804 805 806 807 808 813 814 815 816 817 821 822 823 824 825 831
 832 833 834 841 842 843 844 845 851 852 853 854 855 921 922 923 931 932

94005C02.1

6199042M3

1

Jan-06

Reverse Alarm
Alarme de Marche Arrière
Alarma de marcha trasera

C-95025-01.1-A

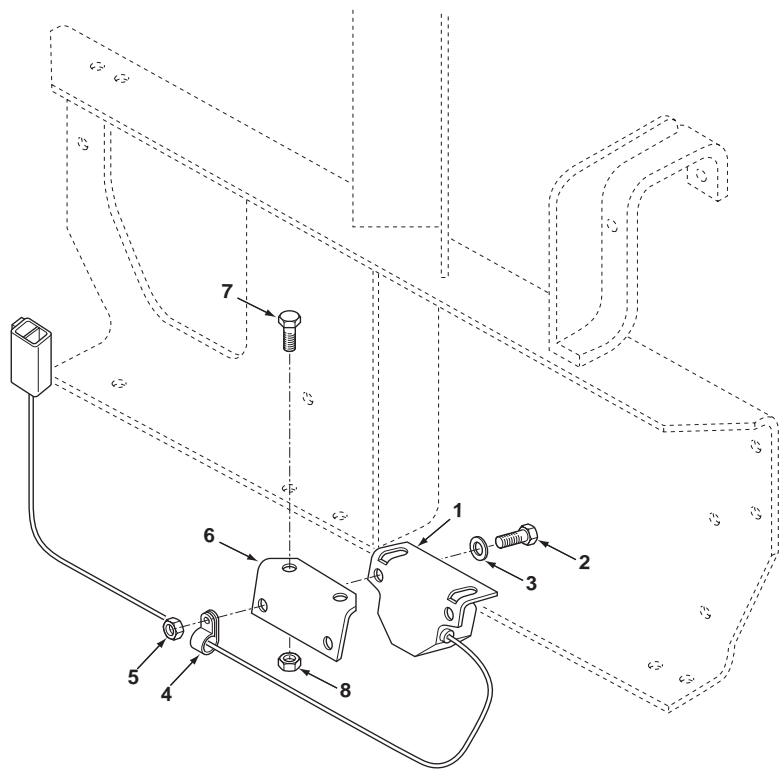

1	6102964M91		1	Alarm	Alarme	Alarma
2	339123X1	M8 x 20	2	Bolt	Boulon	Perno
3	390972X1	M8	2	Washer	Rondelle	Arandela
4	3517114M2		1	Clip, Mounting	Collier de fixation	Argolla de fijación
5	394367X1	M8	2	Nut, Lock	Écrou de blocage	Tuerca de retención
6	6102972M1		1	Bracket	Patte de fixation	Pata de fijación
7	339666X1	M6 x 20	2	Screw	Vis	Tornillo
8	1441500X1	M6	2	Nut, Lock	Écrou de blocage	Tuerca de retención



820 860 880 970 980
 TX760B TX860B
 TX870B TX970B

801 802 803 804 805 806 807 808 809 810 811 812 813 814 815 816 817 821 822
 823 824 825 831 832 833 834 841 842 843 844 845 851 852 853 854 855 921 922
 923 931 932

95025C01.1

6199042M3

1

Jan-06

Ride Control
Circuit Hydraulique
Control anticabeceo

Hydraulic Circuit
Système Anti-Tangage
Circuito hidráulico

English
 Anglais
 Inglés

C-64001-01.1-B

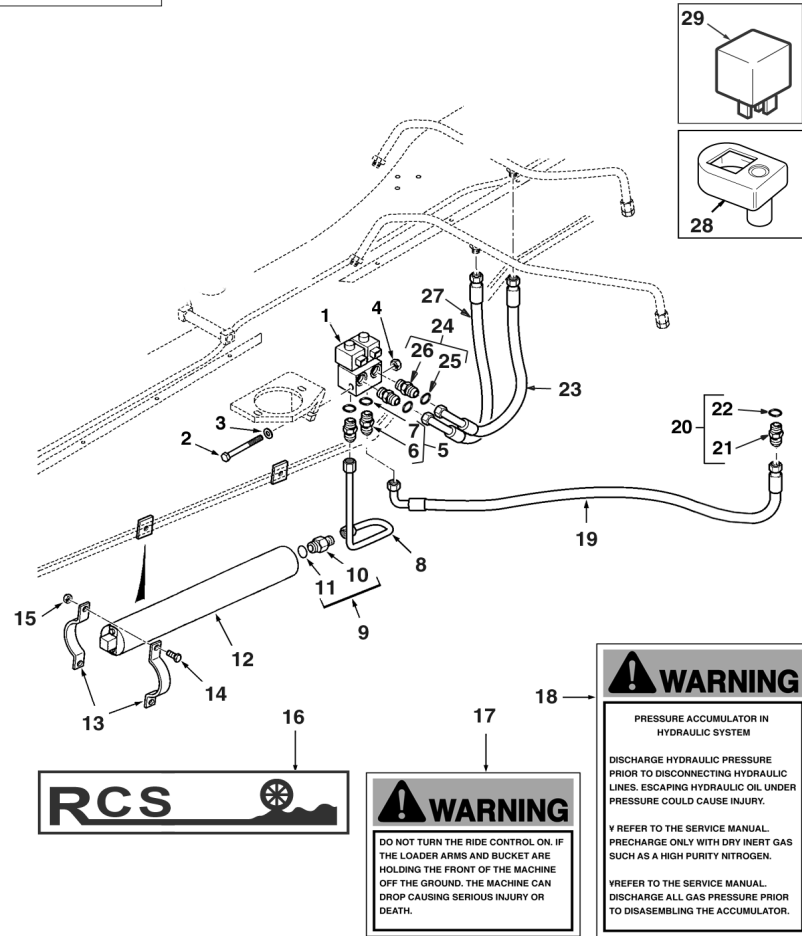

1	6100522M91	64001C02.1 1	1	Valve, Pilot	Soupape de pilotage	Válvula de pilotaje
2	3009504X1	M10 x 100	1	Screw	Vis	Tornillo
3	385362X1	M10	1	Washer	Rondelle	Arandela
4	1440329X1	M10	1	Nut, Lock	Écrou de blocage	Tuerca de retención
5	358743X91	3/4"	2	Union	Union	Unión
6		Ref. 5	1	Union	Union	Unión
7	831497M1	5	1	O-Ring	Joint torique	Junta de tipo O
8	6109373M91		1	Tube Assy	Tuyauterie	Conjunto de tubería
9	3519179M91		1	Connector Assy	Ensemble connexion	Conexión, Conj.
10		Ref. 9	1	Union	Union	Unión
11	831452M1	9	1	O-Ring	Joint torique	Junta de tipo O
12	6106193M92		1	Accumulator	Accumulateur	Acumulador
13	6101361M1		4	Bracket, Clamp	Bride de fixation	Brida de fijación
14	339337X1	M8 x 30	4	Bolt	Boulon	Perno
15	394367X1	M8	4	Nut, Lock	Écrou de blocage	Tuerca de retención
16	6108851M1		2	Decal	Adhésif	Adhesivo
17	255927A1		1	Decal	Adhésif	Adhesivo
18	256318A1		1	Decal	Adhésif	Adhesivo
19	6109375M91		1	Hose Assy	Ensemble de flexible	Flexible, Conj.
20	6109376M91		1	Connector Assy	Ensemble connexion	Conexión, Conj.
21		Ref. 20	1	Connector	Connecteur	Conector
22	835026M1	20	1	O-Ring	Joint torique	Junta de tipo O
23	6109468M91		1	Hose Assy	Ensemble de flexible	Flexible, Conj.
24	360202X91		2	Union	Union	Unión
25		Ref. 24	1	Union	Union	Unión
26	831497M1	24	1	O-Ring	Joint torique	Junta de tipo O
27	6110180M91		1	Hose Assy	Ensemble de flexible	Flexible, Conj.
28	6101777M91	Switch	1	Cover	Cache	Tapa
29	6102490M1		1	Relay	Relais	Relé



820 860 880 970 980
 TX760B TX860B
 TX870B TX970B

801 802 803 804 805 806 807 808 809 810 811 812 813 814 815 816 817 821 822
 823 824 825 831 832 833 834 841 842 843 844 845 851 852 853 854 855 921 922
 923 931 932

64001C01.1

6199042M3

1

Jan-06

Ride Control
Circuit Hydraulique
Control anticabeceo

Hydraulic Circuit
Système Anti-Tangage
Circuito hidráulico

English
Anglais
Inglés

Solenoid Valve
Solenoid Valve
Solenoid Valve

C-64001-02.1-A

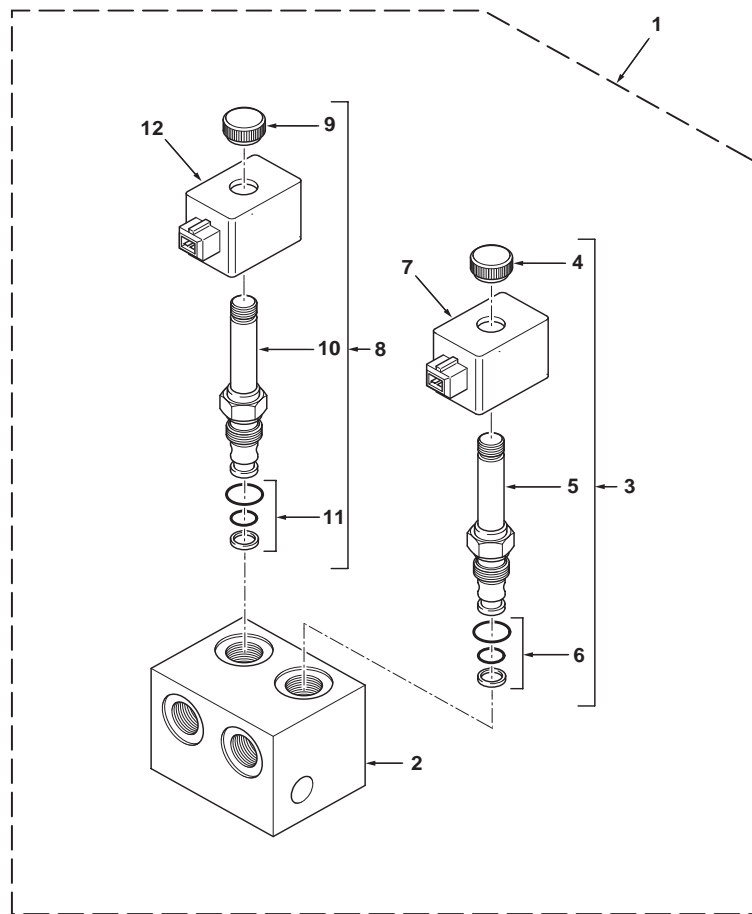

1	6100522M91		64001C01.1 1	1	Valve, Pilot	Soupape de pilotage	Válvula de pilotaje
2		1	Ref. 1	1	Body	Corps	Cuerpo
3	6190749M91	1		1	Solenoid	Solénoïde	Solenoid
4		3	Ref. 3	1	Nut	Écrou	Tuerca
5		3	Ref. 3	1	Spool	Tiroir	Cajoncillo
6	6190752M91	3		1	Kit, Seal	Pochette de joints	Juego de juntas
7	6191096M91	1	12V	1	Coil	Bobine	Bobina
8	6190750M91	1		1	Solenoid	Solénoïde	Solenoid
9		8	Ref. 8	1	Nut	Écrou	Tuerca
10		8	Ref. 8	1	Spool	Tiroir	Cajoncillo
11	6190752M91	8		1	Kit, Seal	Pochette de joints	Juego de juntas
12	6191096M91	1	12V	1	Coil	Bobine	Bobina



820 860 880 970 980
TX760B TX860B
TX870B TX970B

801 802 803 804 805 806 807 808 809 810 811 812 813 814 815 816 817 821 822
823 824 825 831 832 833 834 841 842 843 844 845 851 852 853 854 855 921 922
923 931 932

64001C02.1

6199042M3

1

Jan-06

Ride Control
Circuit Hydraulique
Control anticabeceo

Hydraulic Circuit
Système Anti-Tangage
Circuito hidráulico

Less Ride Control
Sans Système Anti-Tangage
Sin control anticabeceo

C-64002-01.1-A

1	356579X1			2	Cap	Chapeau	Sombrerete
---	----------	--	--	---	-----	---------	------------

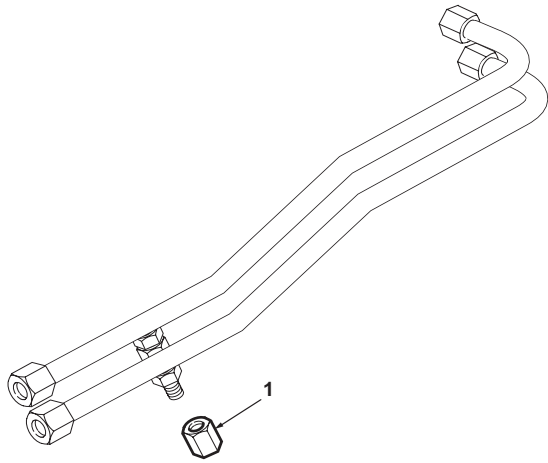

820 860 880 970 980
TX760B TX860B
TX870B TX970B

801 802 803 804 805 806 807 808 809 810 811 812 813 814 815 816 817 821 822
823 824 825 831 832 833 834 841 842 843 844 845 851 852 853 854 855 921 922
923 931 932

64002C01.1

6199042M3

1

Jan-06

Ride Control
Circuit Hydraulique
Control anticabeceo

Hydraulic Circuit
Système Anti-Tangage
Circuito hidráulico

French
Français
Francés

C-64004-01.1-B

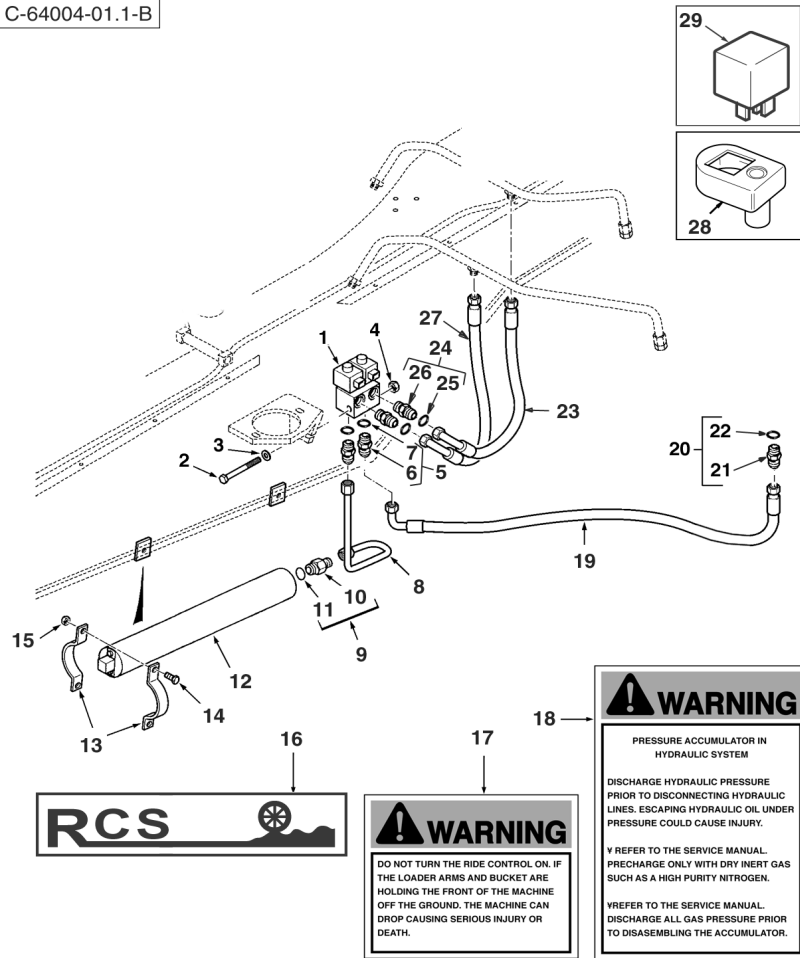

1	6100522M91	64004C02.1 1	1	Valve, Pilot	Soupape de pilotage	Válvula de pilotaje
2	3009504X1	M10 x 100	1	Screw	Vis	Tornillo
3	385362X1	M10	1	Washer	Rondelle	Arandela
4	1440329X1	M10	1	Nut, Lock	Écrou de blocage	Tuerca de retención
5	358743X91	3/4"	2	Union	Union	Unión
6		Ref. 5	1	Union	Union	Unión
7	831497M1	5	1	O-Ring	Joint torique	Junta de tipo O
8	6109373M91		1	Tube Assy	Tuyauterie	Conjunto de tubería
9	3519179M91		1	Connector Assy	Ensemble connexion	Conexión, Conj.
10		Ref. 9	1	Union	Union	Unión
11	831452M1	9	1	O-Ring	Joint torique	Junta de tipo O
12	6106193M92		1	Accumulator	Accumulateur	Acumulador
13	6101361M1		4	Bracket, Clamp	Bride de fixation	Brida de fijación
14	339337X1	M8 x 30	4	Bolt	Boulon	Perno
15	394367X1	M8	4	Nut, Lock	Écrou de blocage	Tuerca de retención
16	6108851M1		2	Decal	Adhésif	Adhesivo
17	256464A1		1	Decal	Adhésif	Adhesivo
18	256453A1		1	Decal	Adhésif	Adhesivo
19	6109375M91		1	Hose Assy	Ensemble de flexible	Flexible, Conj.
20	6109376M91		1	Connector Assy	Ensemble connexion	Conexión, Conj.
21		Ref. 20	1	Connector	Connecteur	Conector
22	835026M1	20	1	O-Ring	Joint torique	Junta de tipo O
23	6109468M91		1	Hose Assy	Ensemble de flexible	Flexible, Conj.
24	360202X91		2	Union	Union	Unión
25		Ref. 24	1	Union	Union	Unión
26	831497M1	24	1	O-Ring	Joint torique	Junta de tipo O
27	6110180M91		1	Hose Assy	Ensemble de flexible	Flexible, Conj.
28	6101777M91	Switch	1	Cover	Cache	Tapa
29	6102490M1		1	Relay	Relais	Relé



820 860 880 970 980
TX760B TX860B
TX870B TX970B

801 802 803 804 805 806 807 808 813 814 815 816 817 821 822 823 824 825 831
832 833 834 841 842 843 844 845 851 852 853 854 855 921 922 923 931 932

64004C01.1

6199042M3

1

Jan-06

Ride Control
Circuit Hydraulique
Control anticabeceo

Hydraulic Circuit
Système Anti-Tangage
Circuito hidráulico

French
Français
Francés

Solenoid Valve
Solenoid Valve
Solenoid Valve

C-64004-02.1-A

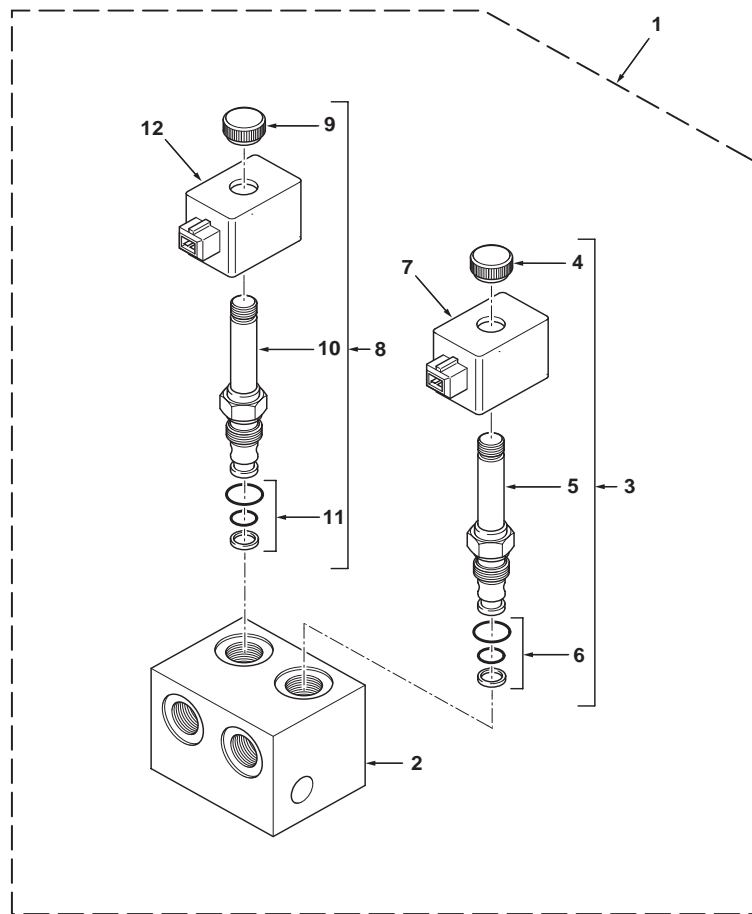

1	6100522M91		64004C01.1 1	1	Valve, Pilot	Soupape de pilotage	Válvula de pilotaje
2		1	Ref. 1	1	Body	Corps	Cuerpo
3	6190749M91	1		1	Solenoid	Solénoïde	Solenoid
4		3	Ref. 3	1	Nut	Écrou	Tuerca
5		3	Ref. 3	1	Spool	Tiroir	Cajoncillo
6	6190752M91	3		1	Kit, Seal	Pochette de joints	Juego de juntas
7	6191096M91	1	12V	1	Coil	Bobine	Bobina
8	6190750M91	1		1	Solenoid	Solénoïde	Solenoid
9		8	Ref. 8	1	Nut	Écrou	Tuerca
10		8	Ref. 8	1	Spool	Tiroir	Cajoncillo
11	6190752M91	8		1	Kit, Seal	Pochette de joints	Juego de juntas
12	6191096M91	1	12V	1	Coil	Bobine	Bobina



820 860 880 970 980
TX760B TX860B
TX870B TX970B

801 802 803 804 805 806 807 808 813 814 815 816 817 821 822 823 824 825 831
832 833 834 841 842 843 844 845 851 852 853 854 855 921 922 923 931 932

64004C02.1

6199042M3

1

Jan-06

**Ride Control
Circuit Hydraulique
Control anticabeceo**

**Hydraulic Circuit
Système Anti-Tangage
Circuito hidráulico**

German
Allemand
Alemán

C-64005-01.1-B

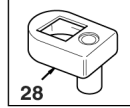
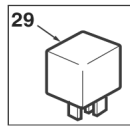
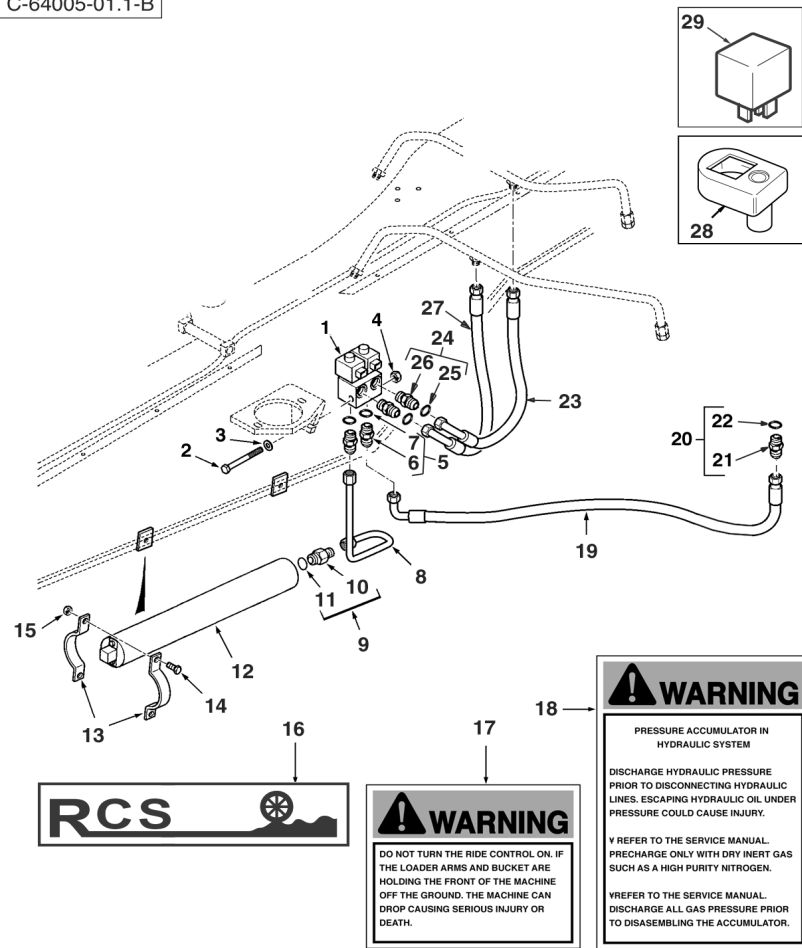

1	6100522M91	64005C02.1 1	1	Valve, Pilot	Soupape de pilotage	Válvula de pilotaje
2	3009504X1	M10 x 100	1	Screw	Vis	Tornillo
3	385362X1	M10	1	Washer	Rondelle	Arandela
4	1440329X1	M10	1	Nut, Lock	Écrou de blocage	Tuerca de retención
5	358743X91	3/4"	2	Union	Union	Unión
6		Ref. 5	1	Union	Union	Unión
7	831497M1	5	1	O-Ring	Joint torique	Junta de tipo O
8	6109373M91		1	Tube Assy	Tuyauterie	Conjunto de tubería
9	3519179M91		1	Connector Assy	Ensemble connexion	Conexión, Conj.
10		Ref. 9	1	Union	Union	Unión
11	831452M1	9	1	O-Ring	Joint torique	Junta de tipo O
12	6106193M92		1	Accumulator	Accumulateur	Acumulador
13	6101361M1		4	Bracket, Clamp	Bride de fixation	Brida de fijación
14	339337X1	M8 x 30	4	Bolt	Boulon	Perno
15	394367X1	M8	4	Nut, Lock	Écrou de blocage	Tuerca de retención
16	6108851M1		2	Decal	Adhésif	Adhesivo
17	256465A1		1	Decal	Adhésif	Adhesivo
18	256454A1		1	Decal	Adhésif	Adhesivo
19	6109375M91		1	Hose Assy	Ensemble de flexible	Flexible, Conj.
20	6109376M91		1	Connector Assy	Ensemble connexion	Conexión, Conj.
21		Ref. 20	1	Connector	Connecteur	Conector
22	835026M1	20	1	O-Ring	Joint torique	Junta de tipo O
23	6109468M91		1	Hose Assy	Ensemble de flexible	Flexible, Conj.
24	360202X91		2	Union	Union	Unión
25		Ref. 24	1	Union	Union	Unión
26	831497M1	24	1	O-Ring	Joint torique	Junta de tipo O
27	6110180M91		1	Hose Assy	Ensemble de flexible	Flexible, Conj.
28	6101777M91	Switch	1	Cover	Cache	Tapa
29	6102490M1		1	Relay	Relais	Relé



820 860 880 970 980
TX760B TX860B
TX870B TX970B

801 802 803 804 805 806 807 808 813 814 815 816 817 821 822 823 824 825 831
832 833 834 841 842 843 844 845 851 852 853 854 855 921 922 923 931 932

64005C01.1

6199042M3

1

Jan-06

Ride Control
Circuit Hydraulique
Control anticabeceo

Hydraulic Circuit
Système Anti-Tangage
Circuito hidráulico

German
Allemand
Alemán

Solenoid Valve
Solenoid Valve
Solenoid Valve

C-64005-02.1-A

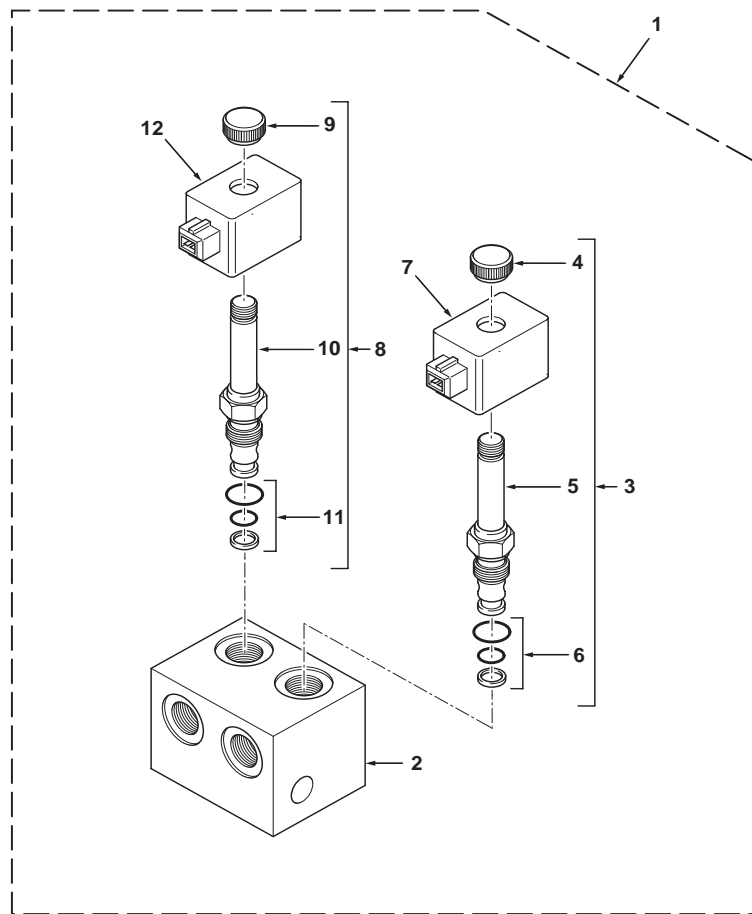

1	6100522M91		64005C01.1 1	1	Valve, Pilot	Soupape de pilotage	Válvula de pilotaje
2		1	Ref. 1	1	Body	Corps	Cuerpo
3	6190749M91	1		1	Solenoid	Solénoïde	Solenoid
4		3	Ref. 3	1	Nut	Écrou	Tuerca
5		3	Ref. 3	1	Spool	Tiroir	Cajoncillo
6	6190752M91	3		1	Kit, Seal	Pochette de joints	Juego de juntas
7	6191096M91	1	12V	1	Coil	Bobine	Bobina
8	6190750M91	1		1	Solenoid	Solénoïde	Solenoid
9		8	Ref. 8	1	Nut	Écrou	Tuerca
10		8	Ref. 8	1	Spool	Tiroir	Cajoncillo
11	6190752M91	8		1	Kit, Seal	Pochette de joints	Juego de juntas
12	6191096M91	1	12V	1	Coil	Bobine	Bobina



820 860 880 970 980
TX760B TX860B
TX870B TX970B

801 802 803 804 805 806 807 808 813 814 815 816 817 821 822 823 824 825 831
832 833 834 841 842 843 844 845 851 852 853 854 855 921 922 923 931 932

64005C02.1

6199042M3

1

Jan-06

**Ride Control
Circuit Hydraulique
Control anticabeceo**

**Hydraulic Circuit
Système Anti-Tangage
Circuito hidráulico**

Italian
Italien
Italiano

C-64006-01.1-B

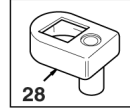
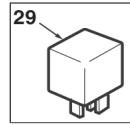
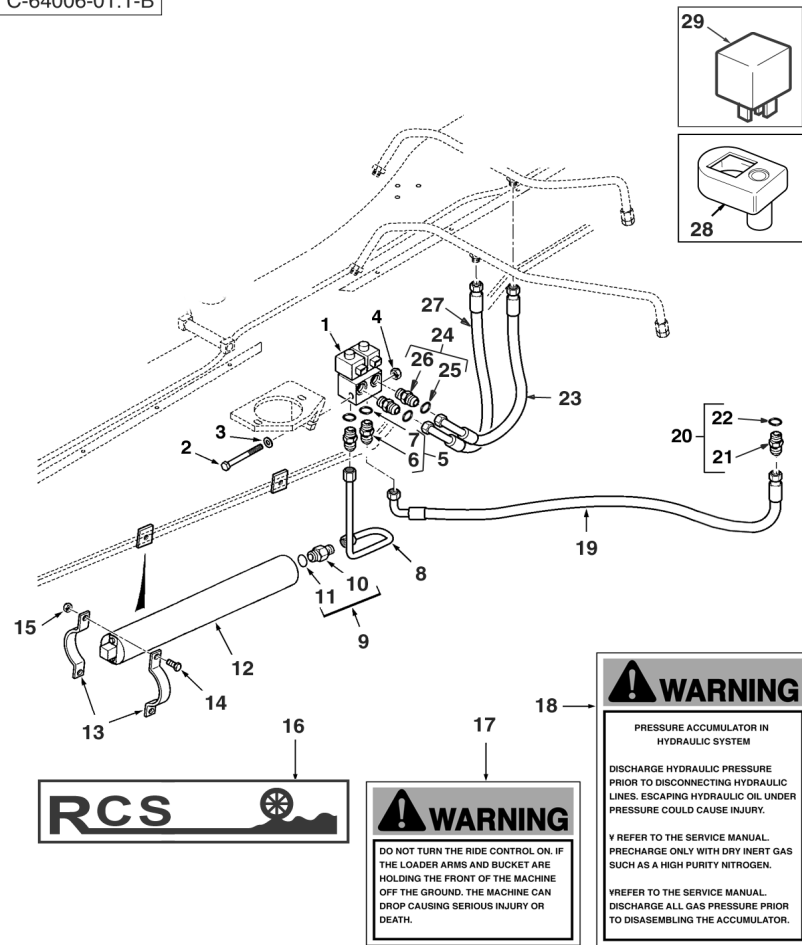

1	6100522M91	64006C02.1 1	1	Valve, Pilot	Soupape de pilotage	Válvula de pilotaje
2	3009504X1	M10 x 100	1	Screw	Vis	Tornillo
3	385362X1	M10	1	Washer	Rondelle	Arandela
4	1440329X1	M10	1	Nut, Lock	Écrou de blocage	Tuerca de retención
5	358743X91	3/4"	2	Union	Union	Unión
6		Ref. 5	1	Union	Union	Unión
7	831497M1	5	1	O-Ring	Joint torique	Junta de tipo O
8	6109373M91		1	Tube Assy	Tuyauterie	Conjunto de tubería
9	3519179M91		1	Connector Assy	Ensemble connexion	Conexión, Conj.
10		Ref. 9	1	Union	Union	Unión
11	831452M1	9	1	O-Ring	Joint torique	Junta de tipo O
12	6106193M92		1	Accumulator	Accumulateur	Acumulador
13	6101361M1		4	Bracket, Clamp	Bride de fixation	Brida de fijación
14	339337X1	M8 x 30	4	Bolt	Boulon	Perno
15	394367X1	M8	4	Nut, Lock	Écrou de blocage	Tuerca de retención
16	6108851M1		2	Decal	Adhésif	Adhesivo
17	256468A1		1	Decal	Adhésif	Adhesivo
18	256457A1		1	Decal	Adhésif	Adhesivo
19	6109375M91		1	Hose Assy	Ensemble de flexible	Flexible, Conj.
20	6109376M91		1	Connector Assy	Ensemble connexion	Conexión, Conj.
21		Ref. 20	1	Connector	Connecteur	Conector
22	835026M1	20	1	O-Ring	Joint torique	Junta de tipo O
23	6109468M91		1	Hose Assy	Ensemble de flexible	Flexible, Conj.
24	360202X91		2	Union	Union	Unión
25		Ref. 24	1	Union	Union	Unión
26	831497M1	24	1	O-Ring	Joint torique	Junta de tipo O
27	6110180M91		1	Hose Assy	Ensemble de flexible	Flexible, Conj.
28	6101777M91	Switch	1	Cover	Cache	Tapa
29	6102490M1		1	Relay	Relais	Relé



820 860 880 970 980
TX760B TX860B
TX870B TX970B

801 802 803 804 805 806 807 808 813 814 815 816 817 821 822 823 824 825 831
832 833 834 841 842 843 844 845 851 852 853 854 855 921 922 923 931 932

64006C01.1

6199042M3

1

Jan-06

Ride Control
Circuit Hydraulique
Control anticabeceo

Hydraulic Circuit
Système Anti-Tangage
Circuito hidráulico

Italian
Italien
Italiano

Solenoid Valve
Solenoid Valve
Solenoid Valve

C-64006-02.1-A

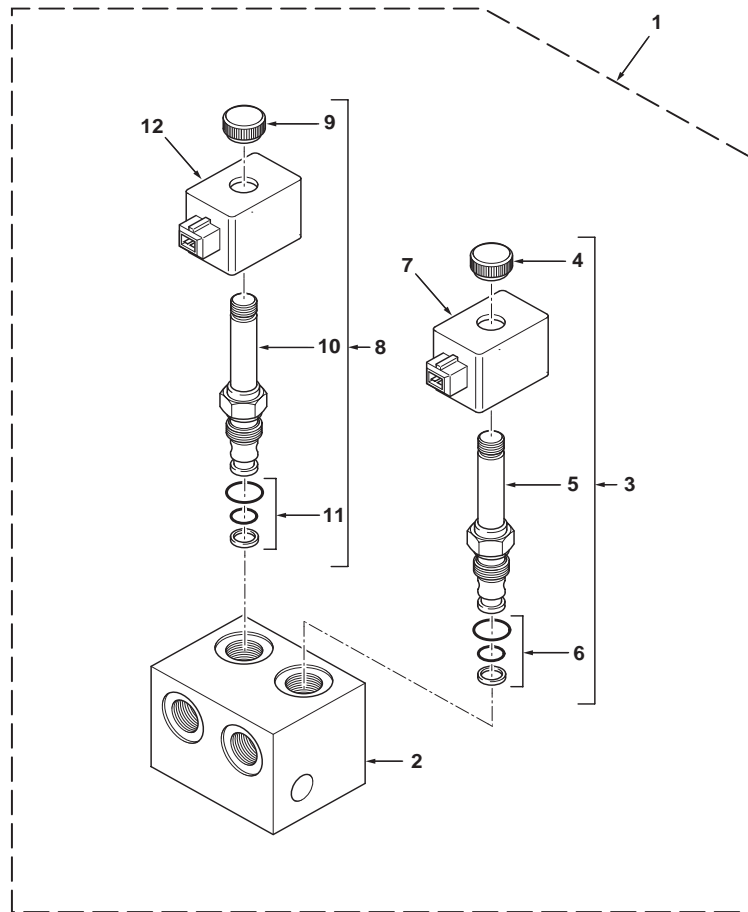

1	6100522M91		64006C01.1 1	1	Valve, Pilot	Soupape de pilotage	Válvula de pilotaje
2		1	Ref. 1	1	Body	Corps	Cuerpo
3	6190749M91	1		1	Solenoid	Solénoïde	Solenoid
4		3	Ref. 3	1	Nut	Écrou	Tuerca
5		3	Ref. 3	1	Spool	Tiroir	Cajoncillo
6	6190752M91	3		1	Kit, Seal	Pochette de joints	Juego de juntas
7	6191096M91	1	12V	1	Coil	Bobine	Bobina
8	6190750M91	1		1	Solenoid	Solénoïde	Solenoid
9		8	Ref. 8	1	Nut	Écrou	Tuerca
10		8	Ref. 8	1	Spool	Tiroir	Cajoncillo
11	6190752M91	8		1	Kit, Seal	Pochette de joints	Juego de juntas
12	6191096M91	1	12V	1	Coil	Bobine	Bobina



820 860 880 970 980
TX760B TX860B
TX870B TX970B

801 802 803 804 805 806 807 808 813 814 815 816 817 821 822 823 824 825 831
832 833 834 841 842 843 844 845 851 852 853 854 855 921 922 923 931 932

64006C02.1

6199042M3

1

Jan-06

**Ride Control
Circuit Hydraulique
Control anticabeceo**

**Hydraulic Circuit
Système Anti-Tangage
Circuito hidráulico**

Spanish
Español
Español

C-64007-01.1-B

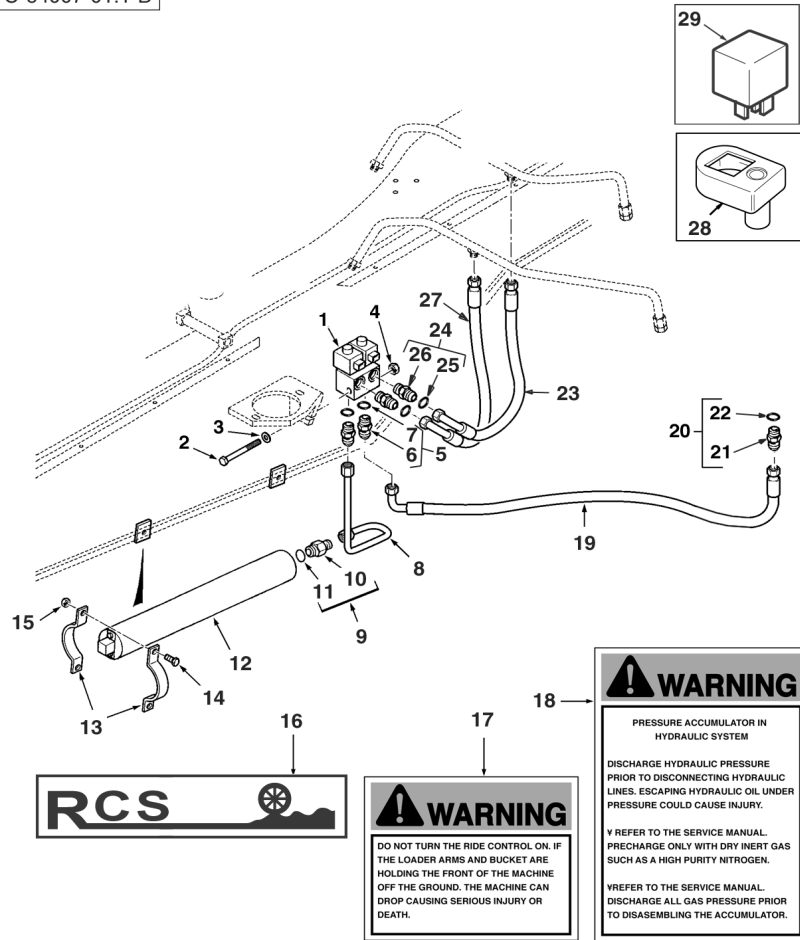

1	6100522M91	64007C02.1 1	1	Valve, Pilot	Soupape de pilotage	Válvula de pilotaje
2	3009504X1	M10 x 100	1	Screw	Vis	Tornillo
3	385362X1	M10	1	Washer	Rondelle	Arandela
4	1440329X1	M10	1	Nut, Lock	Écrou de blocage	Tuerca de retención
5	358743X91	3/4"	2	Union	Union	Unión
6		Ref. 5	1	Union	Union	Unión
7	831497M1	5	1	O-Ring	Joint torique	Junta de tipo O
8	6109373M91		1	Tube Assy	Tuyauterie	Conjunto de tubería
9	3519179M91		1	Connector Assy	Ensemble connexion	Conexión, Conj.
10		Ref. 9	1	Union	Union	Unión
11	831452M1	9	1	O-Ring	Joint torique	Junta de tipo O
12	6106193M92		1	Accumulator	Accumulateur	Acumulador
13	6101361M1		4	Bracket, Clamp	Bride de fixation	Brida de fijación
14	339337X1	M8 x 30	4	Bolt	Boulon	Perno
15	394367X1	M8	4	Nut, Lock	Écrou de blocage	Tuerca de retención
16	6108851M1		2	Decal	Adhésif	Adhesivo
17	256467A1		1	Decal	Adhésif	Adhesivo
18	256456A1		1	Decal	Adhésif	Adhesivo
19	6109375M91		1	Hose Assy	Ensemble de flexible	Flexible, Conj.
20	6109376M91		1	Connector Assy	Ensemble connexion	Conexión, Conj.
21		Ref. 20	1	Connector	Connecteur	Conector
22	835026M1	20	1	O-Ring	Joint torique	Junta de tipo O
23	6109468M91		1	Hose Assy	Ensemble de flexible	Flexible, Conj.
24	360202X91		2	Union	Union	Unión
25		Ref. 24	1	Union	Union	Unión
26	831497M1	24	1	O-Ring	Joint torique	Junta de tipo O
27	6110180M91		1	Hose Assy	Ensemble de flexible	Flexible, Conj.
28	6101777M91	Switch	1	Cover	Cache	Tapa
29	6102490M1		1	Relay	Relais	Relé



820 860 880 970 980
TX760B TX860B
TX870B TX970B

801 802 803 804 805 806 807 808 811 812 813 814 815 816 817 821 822 823 824
825 831 832 833 834 841 842 843 844 845 851 852 853 854 855 921 922 923 931
932

64007C01.1

6199042M3

1

Jan-06

Ride Control
Circuit Hydraulique
Control anticabeceo

Hydraulic Circuit
Système Anti-Tangage
Circuito hidráulico

Spanish
Español
Español

Solenoid Valve
Solenoid Valve
Solenoid Valve

C-64007-02.1-A

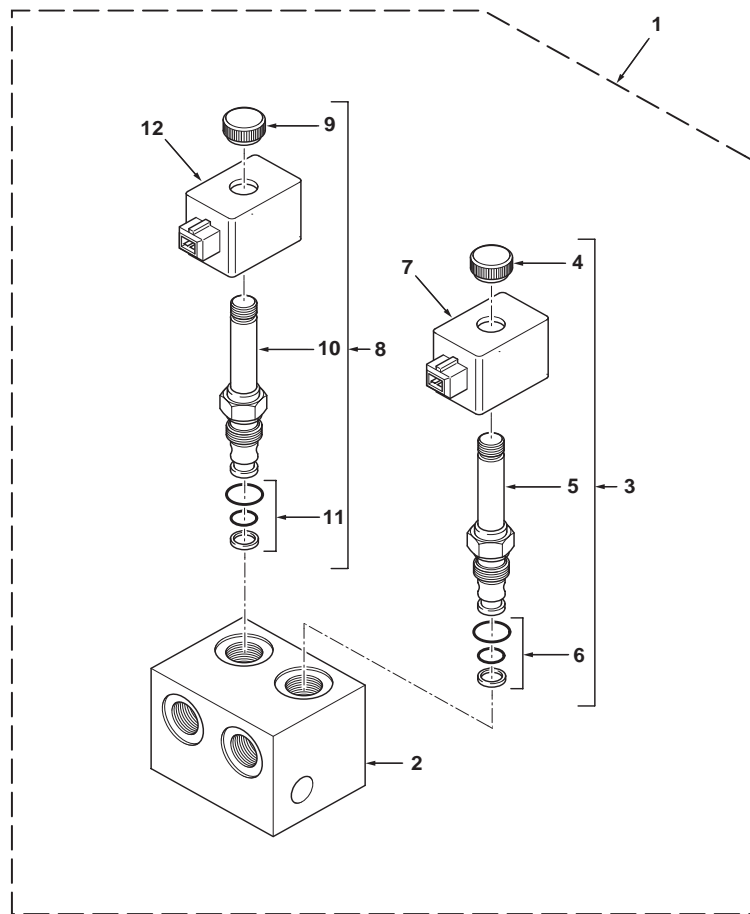

1	6100522M91		64007C01.1 1	1	Valve, Pilot	Soupape de pilotage	Válvula de pilotaje
2		1	Ref. 1	1	Body	Corps	Cuerpo
3	6190749M91	1		1	Solenoid	Solénoïde	Solenoid
4		3	Ref. 3	1	Nut	Écrou	Tuerca
5		3	Ref. 3	1	Spool	Tiroir	Cajoncillo
6	6190752M91	3		1	Kit, Seal	Pochette de joints	Juego de juntas
7	6191096M91	1	12V	1	Coil	Bobine	Bobina
8	6190750M91	1		1	Solenoid	Solénoïde	Solenoid
9		8	Ref. 8	1	Nut	Écrou	Tuerca
10		8	Ref. 8	1	Spool	Tiroir	Cajoncillo
11	6190752M91	8		1	Kit, Seal	Pochette de joints	Juego de juntas
12	6191096M91	1	12V	1	Coil	Bobine	Bobina



820 860 880 970 980
TX760B TX860B
TX870B TX970B

801 802 803 804 805 806 807 808 811 812 813 814 815 816 817 821 822 823 824
825 831 832 833 834 841 842 843 844 845 851 852 853 854 855 921 922 923 931
932

64007C02.1

6199042M3

1

Jan-06

Ride Control
Circuit Hydraulique
Control anticabeceo

Hydraulic Circuit
Système Anti-Tangage
Circuito hidráulico

Dutch
 Néerlandais
 Holandés

C-64008-01.1-B

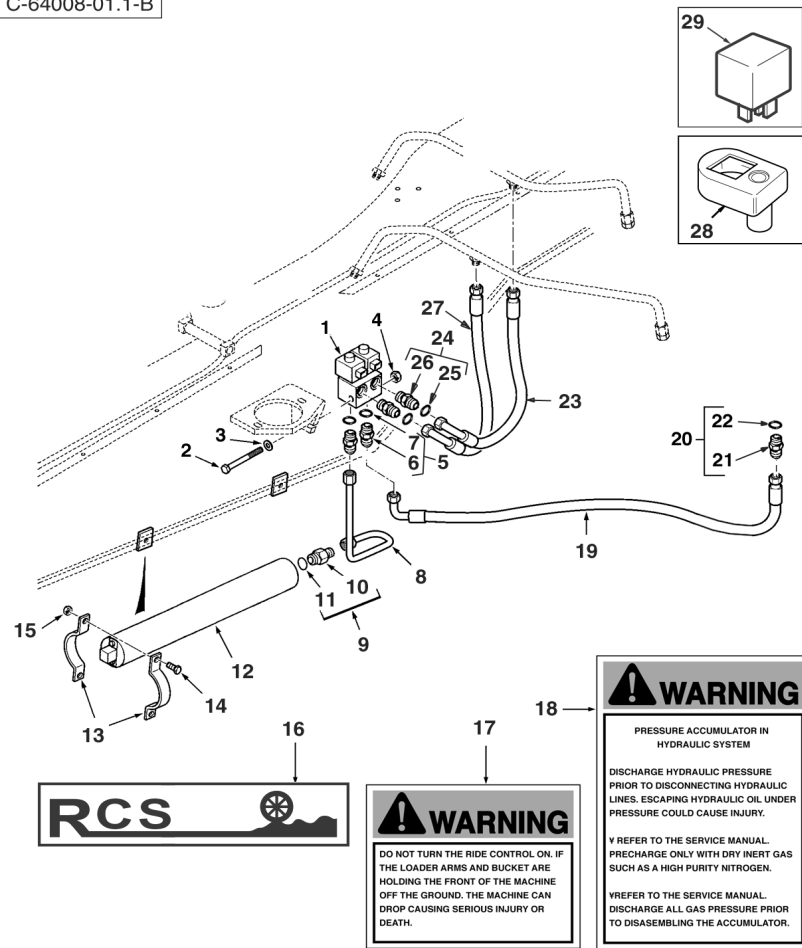

1	6100522M91	64008C02.1 1	1	Valve, Pilot	Soupape de pilotage	Válvula de pilotaje
2	3009504X1	M10 x 100	1	Screw	Vis	Tornillo
3	385362X1	M10	1	Washer	Rondelle	Arandela
4	1440329X1	M10	1	Nut, Lock	Écrou de blocage	Tuerca de retención
5	358743X91	3/4"	2	Union	Union	Unión
6		5 Ref. 5	1	Union	Union	Unión
7	831497M1	5	1	O-Ring	Joint torique	Junta de tipo O
8	6109373M91		1	Tube Assy	Tuyauterie	Conjunto de tubería
9	3519179M91		1	Connector Assy	Ensemble connexion	Conexión, Conj.
10		9 Ref. 9	1	Union	Union	Unión
11	831452M1	9	1	O-Ring	Joint torique	Junta de tipo O
12	6106193M92		1	Accumulator	Accumulateur	Acumulador
13	6101361M1		4	Bracket, Clamp	Bride de fixation	Brida de fijación
14	339337X1	M8 x 30	4	Bolt	Boulon	Perno
15	394367X1	M8	4	Nut, Lock	Écrou de blocage	Tuerca de retención
16	6108851M1		2	Decal	Adhésif	Adhesivo
17	256474A1		1	Decal	Adhésif	Adhesivo
18	256463A1		1	Decal	Adhésif	Adhesivo
19	6109375M91		1	Hose Assy	Ensemble de flexible	Flexible, Conj.
20	6109376M91		1	Connector Assy	Ensemble connexion	Conexión, Conj.
21		20 Ref. 20	1	Connector	Connecteur	Conector
22	835026M1	20	1	O-Ring	Joint torique	Junta de tipo O
23	6109468M91		1	Hose Assy	Ensemble de flexible	Flexible, Conj.
24	360202X91		2	Union	Union	Unión
25		24 Ref. 24	1	Union	Union	Unión
26	831497M1	24	1	O-Ring	Joint torique	Junta de tipo O
27	6110180M91		1	Hose Assy	Ensemble de flexible	Flexible, Conj.
28	6101777M91	Switch	1	Cover	Cache	Tapa
29	6102490M1		1	Relay	Relais	Relé



820 860 880 970 980
 TX760B TX860B
 TX870B TX970B

801 802 803 804 805 806 807 808 813 814 815 816 817 821 822 823 824 825 831
 832 833 834 841 842 843 844 845 851 852 853 854 855 921 922 923 931 932

64008C01.1

6199042M3

1

Jan-06

Ride Control
Circuit Hydraulique
Control anticabeceo

Hydraulic Circuit
Système Anti-Tangage
Circuito hidráulico

Dutch
Néerlandais
Holandés

Solenoid Valve
Solenoid Valve
Solenoid Valve

C-64008-02.1-A

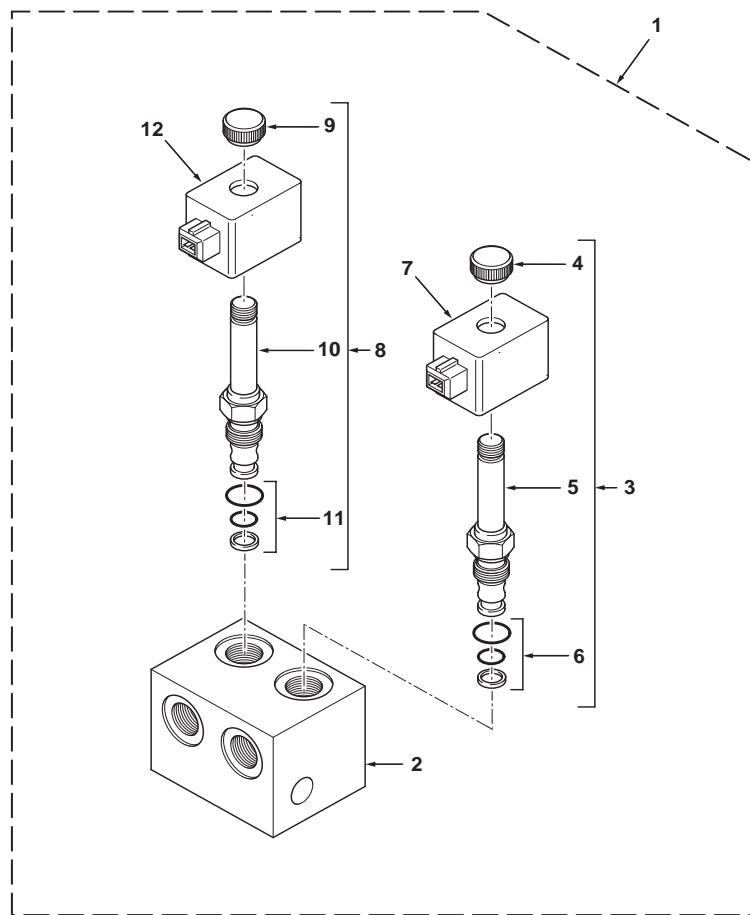

1	6100522M91		64008C01.1 1	1	Valve, Pilot	Soupape de pilotage	Válvula de pilotaje
2		1	Ref. 1	1	Body	Corps	Cuerpo
3	6190749M91	1		1	Solenoid	Solénoïde	Solenoid
4		3	Ref. 3	1	Nut	Écrou	Tuerca
5		3	Ref. 3	1	Spool	Tiroir	Cajoncillo
6	6190752M91	3		1	Kit, Seal	Pochette de joints	Juego de juntas
7	6191096M91	1	12V	1	Coil	Bobine	Bobina
8	6190750M91	1		1	Solenoid	Solénoïde	Solenoid
9		8	Ref. 8	1	Nut	Écrou	Tuerca
10		8	Ref. 8	1	Spool	Tiroir	Cajoncillo
11	6190752M91	8		1	Kit, Seal	Pochette de joints	Juego de juntas
12	6191096M91	1	12V	1	Coil	Bobine	Bobina



820 860 880 970 980
TX760B TX860B
TX870B TX970B

801 802 803 804 805 806 807 808 813 814 815 816 817 821 822 823 824 825 831
832 833 834 841 842 843 844 845 851 852 853 854 855 921 922 923 931 932

64008C02.1

6199042M3

1

Jan-06

**Ride Control
Circuit Hydraulique
Control anticabeceo**

**Hydraulic Circuit
Système Anti-Tangage
Circuito hidráulico**

Danish
Danois
Danés

C-64009-01.1-B

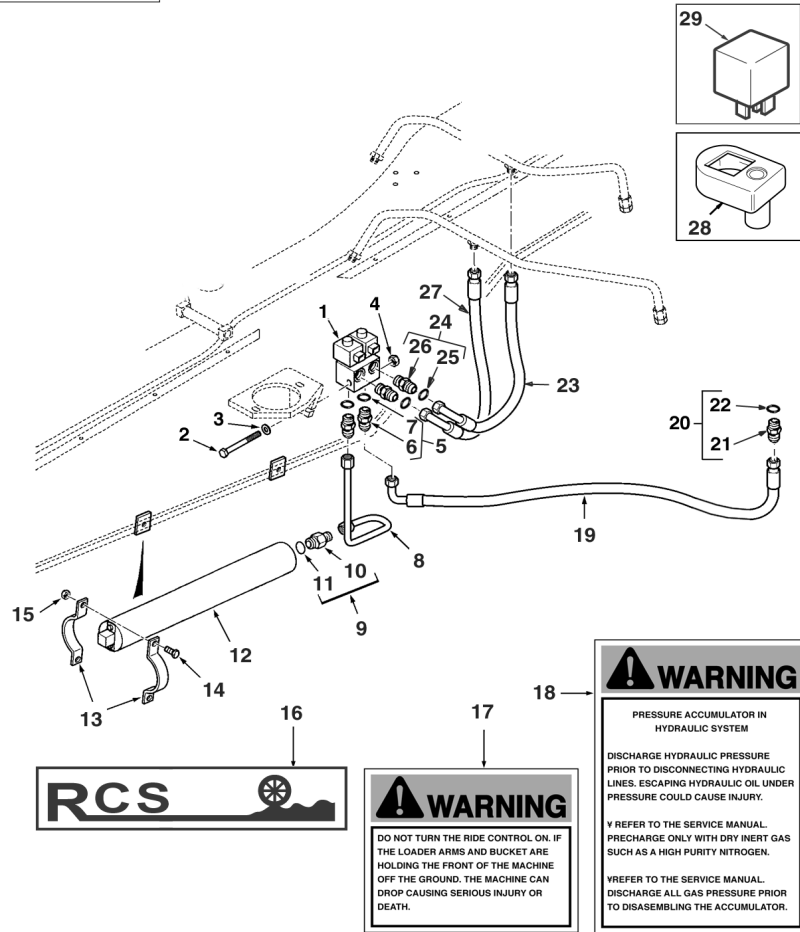

1	6100522M91	64009C02.1 1	1	Valve, Pilot	Soupape de pilotage	Válvula de pilotaje
2	3009504X1	M10 x 100	1	Screw	Vis	Tornillo
3	385362X1	M10	1	Washer	Rondelle	Arandela
4	1440329X1	M10	1	Nut, Lock	Écrou de blocage	Tuerca de retención
5	358743X91	3/4"	2	Union	Union	Unión
6		Ref. 5	1	Union	Union	Unión
7	831497M1	5	1	O-Ring	Joint torique	Junta de tipo O
8	6109373M91		1	Tube Assy	Tuyauterie	Conjunto de tubería
9	3519179M91		1	Connector Assy	Ensemble connexion	Conexión, Conj.
10		Ref. 9	1	Union	Union	Unión
11	831452M1	9	1	O-Ring	Joint torique	Junta de tipo O
12	6106193M92		1	Accumulator	Accumulateur	Acumulador
13	6101361M1		4	Bracket, Clamp	Bride de fixation	Brida de fijación
14	339337X1	M8 x 30	4	Bolt	Boulon	Perno
15	394367X1	M8	4	Nut, Lock	Écrou de blocage	Tuerca de retención
16	6108851M1		2	Decal	Adhésif	Adhesivo
17	256466A1		1	Decal	Adhésif	Adhesivo
18	256455A1		1	Decal	Adhésif	Adhesivo
19	6109375M91		1	Hose Assy	Ensemble de flexible	Flexible, Conj.
20	6109376M91		1	Connector Assy	Ensemble connexion	Conexión, Conj.
21		Ref. 20	1	Connector	Connecteur	Conector
22	835026M1	20	1	O-Ring	Joint torique	Junta de tipo O
23	6109468M91		1	Hose Assy	Ensemble de flexible	Flexible, Conj.
24	360202X91		2	Union	Union	Unión
25		Ref. 24	1	Union	Union	Unión
26	831497M1	24	1	O-Ring	Joint torique	Junta de tipo O
27	6110180M91		1	Hose Assy	Ensemble de flexible	Flexible, Conj.
28	6101777M91	Switch	1	Cover	Cache	Tapa
29	6102490M1		1	Relay	Relais	Relé



820 860 880 970 980
TX760B TX860B
TX870B TX970B

801 802 803 804 805 806 807 808 811 812 813 814 815 816 817 821 822 823 824
825 831 832 833 834 841 842 843 844 845 851 852 853 854 855 921 922 923 931
932

64009C01.1

6199042M3

1

Jan-06

Ride Control
Circuit Hydraulique
Control anticabeceo

Hydraulic Circuit
Système Anti-Tangage
Circuito hidráulico

Danish
Danois
Danés

Solenoid Valve
Solenoid Valve
Solenoid Valve

C-64009-02.1-A

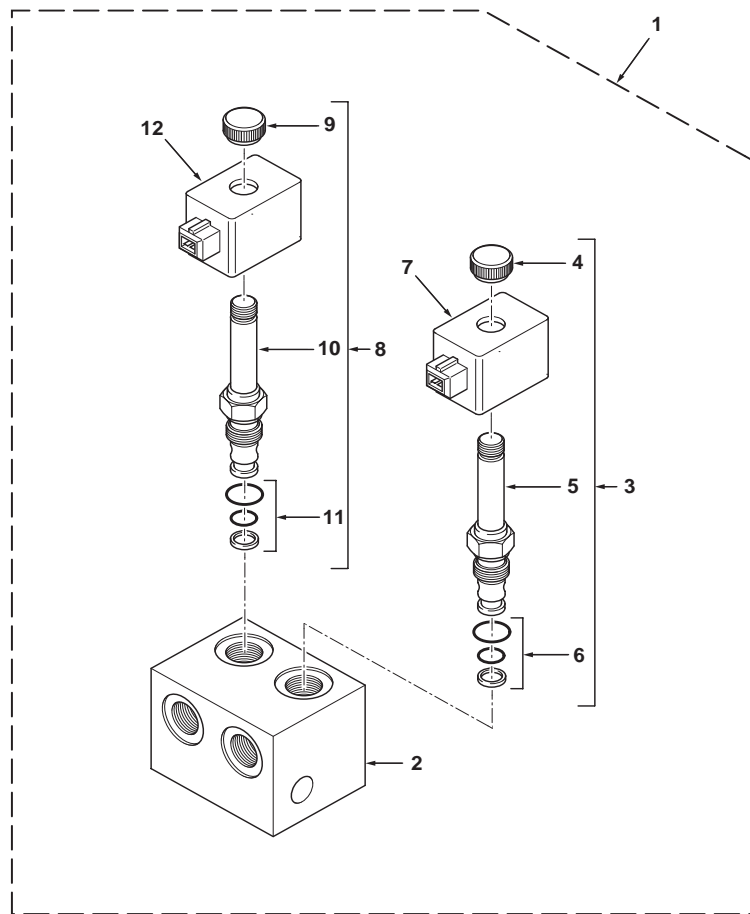

1	6100522M91		64009C01.1 1	1	Valve, Pilot	Soupape de pilotage	Válvula de pilotaje
2		1	Ref. 1	1	Body	Corps	Cuerpo
3	6190749M91	1		1	Solenoid	Solénoïde	Solenoid
4		3	Ref. 3	1	Nut	Écrou	Tuerca
5		3	Ref. 3	1	Spool	Tiroir	Cajoncillo
6	6190752M91	3		1	Kit, Seal	Pochette de joints	Juego de juntas
7	6191096M91	1	12V	1	Coil	Bobine	Bobina
8	6190750M91	1		1	Solenoid	Solénoïde	Solenoid
9		8	Ref. 8	1	Nut	Écrou	Tuerca
10		8	Ref. 8	1	Spool	Tiroir	Cajoncillo
11	6190752M91	8		1	Kit, Seal	Pochette de joints	Juego de juntas
12	6191096M91	1	12V	1	Coil	Bobine	Bobina



820 860 880 970 980
TX760B TX860B
TX870B TX970B

801 802 803 804 805 806 807 808 811 812 813 814 815 816 817 821 822 823 824
825 831 832 833 834 841 842 843 844 845 851 852 853 854 855 921 922 923 931
932

64009C02.1

6199042M3

1

Jan-06

**Ride Control
Circuit Hydraulique
Control anticabeceo**

**Hydraulic Circuit
Système Anti-Tangage
Circuito hidráulico**

C-98036-01.1-B

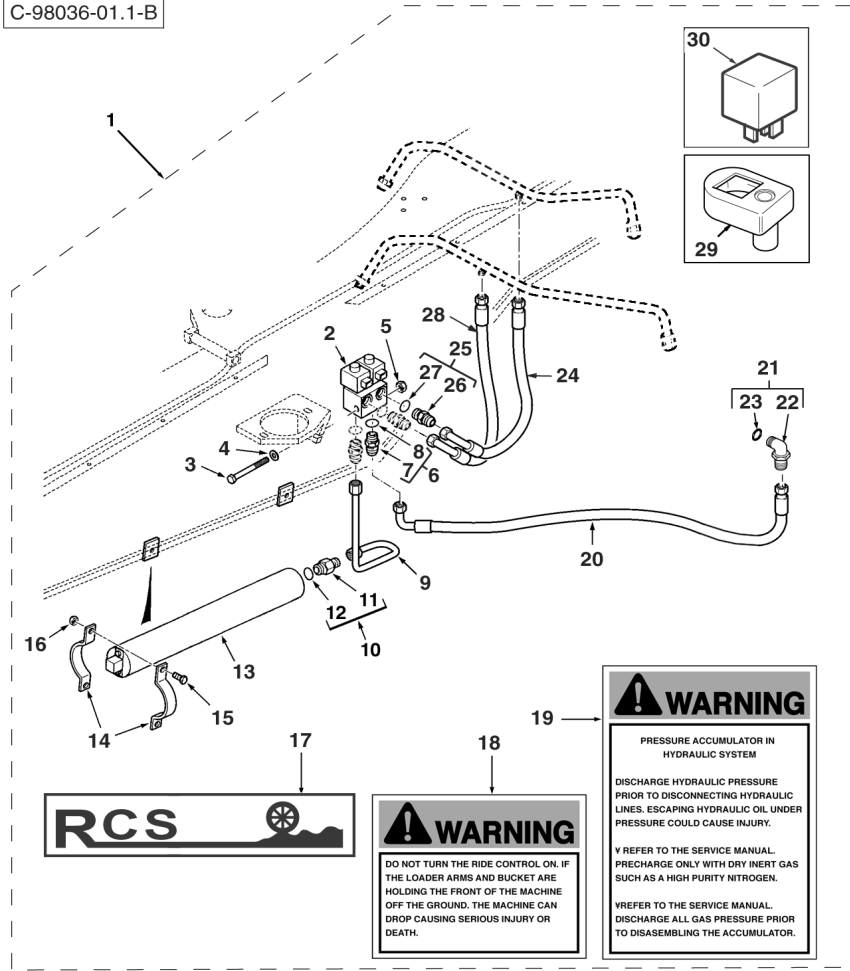

1	6109929M91			1	Ride Control	Système anti-tangage	Control anticabeceo
2	6100522M91	1		1	Valve, Pilot	Soupape de pilotage	Válvula de pilotaje
3	3009504X1	1	M10 x 100	1	Screw	Vis	Tornillo
4	385362X1	1	M10	1	Washer	Rondelle	Arandela
5	1440329X1	1	M10	1	Nut, Lock	Écrou de blocage	Tuerca de retención
6	358743X91	1	3/4"	2	Union	Union	Unión
7		6	➡ Ref. 6	1	Union	Union	Unión
8	831497M1	6		1	O-Ring	Joint torique	Junta de tipo O
9	6109373M91	1		1	Tube Assy	Tuyauterie	Conjunto de tubería
10	3519179M91	1		1	Connector Assy	Ensemble connexion	Conexión, Conj.
11		10	➡ Ref. 10	1	Union	Union	Unión
12	831452M1	10		1	O-Ring	Joint torique	Junta de tipo O
13	6106193M92	1		1	Accumulator	Accumulateur	Acumulador
14	6101361M1	1		4	Bracket, Clamp	Bride de fixation	Brida de fijación
15	339337X1	1	M8 x 30	4	Bolt	Boulon	Perno
16	394367X1	1	M8	4	Nut, Lock	Écrou de blocage	Tuerca de retención
17	6108851M1	1		2	Decal	Adhésif	Adhesivo
18	255927A1	1	(GB)	1	Decal	Adhésif	Adhesivo
18	256464A1	1	(F)	1	Decal	Adhésif	Adhesivo
18	256465A1	1	(D)	1	Decal	Adhésif	Adhesivo
18	256468A1	1	(I)	1	Decal	Adhésif	Adhesivo
18	256467A1	1	(E)	1	Decal	Adhésif	Adhesivo
18	256474A1	1	(NL)	1	Decal	Adhésif	Adhesivo
18	256466A1	1	(DK)	1	Decal	Adhésif	Adhesivo
19	256318A1	1	(GB)	1	Decal	Adhésif	Adhesivo
19	256453A1	1	(F)	1	Decal	Adhésif	Adhesivo
19	256454A1	1	(D)	1	Decal	Adhésif	Adhesivo
19	256457A1	1	(I)	1	Decal	Adhésif	Adhesivo
19	256456A1	1	(E)	1	Decal	Adhésif	Adhesivo
19	256463A1	1	(NL)	1	Decal	Adhésif	Adhesivo
19	256455A1	1	(DK)	1	Decal	Adhésif	Adhesivo
20	6109375M91	1		1	Hose Assy	Ensemble de flexible	Flexible, Conj.
21	6109376M91	1		1	Connector Assy	Ensemble connexion	Conexión, Conj.
22		21	➡ Ref. 21	1	Connector	Connecteur	Conector
23	835026M1	21		1	O-Ring	Joint torique	Junta de tipo O
24	6109468M91	1		1	Hose Assy	Ensemble de flexible	Flexible, Conj.
25	360202X91	1		2	Union	Union	Unión
26		25	➡ Ref. 25	1	Union	Union	Unión
27	831497M1	25		1	O-Ring	Joint torique	Junta de tipo O
28	6110180M91	1		1	Hose Assy	Ensemble de flexible	Flexible, Conj.
29	6101777M91	1	Switch	1	Cover	Cache	Tapa
30	6102490M1	1		1	Relay	Relais	Relé



820 860 880 970 980
TX760B TX860B
TX870B TX970B

801 802 803 804 805 806 807 808 809 810 811 812 813 814 815 816 817 821 822
823 824 825 831 833 841 843 845 851 853 855 921 922 923 931 932

98036C01.1

6199042M3

1

Jan-06

Ride Control
Circuit Hydraulique
Control anticabeceo

Hydraulic Circuit
Système Anti-Tangage
Circuito hidráulico

Rops
Rops
Rops

AC-98130-01.1-A

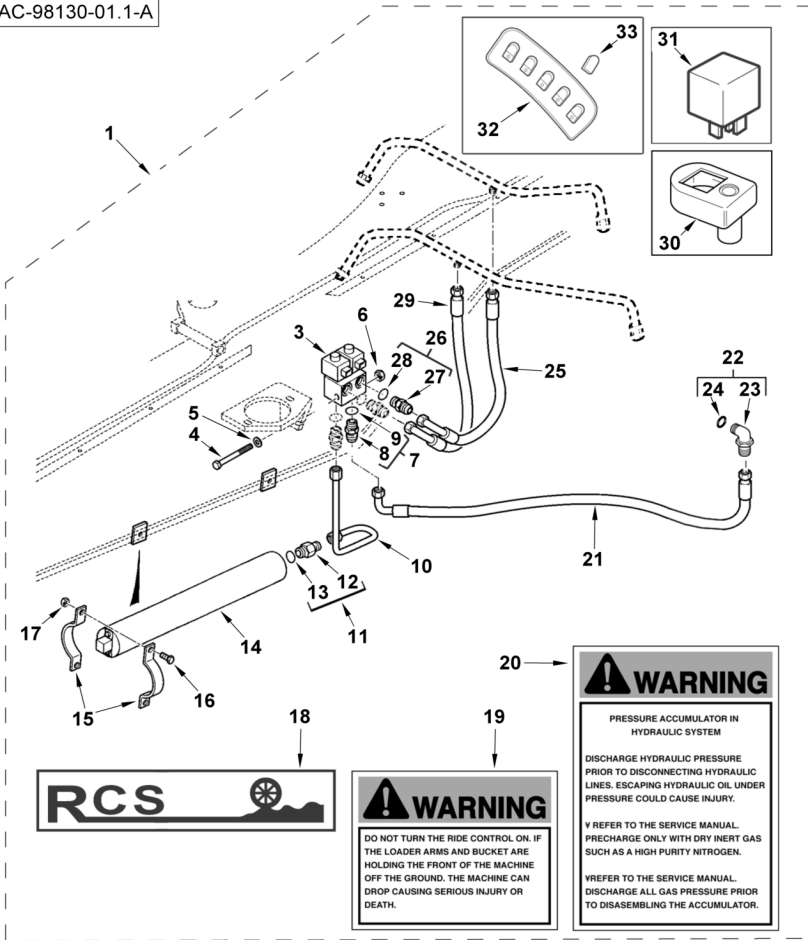

1	ACC61K		Ride Control	1	Accessory code	Code accessoire	Código accesorio
2	6109929M91	1		1	Ride Control	Système anti-tangage	Control anticabeceo
3	6100522M91	2		1	Valve, Pilot	Soupape de pilotage	Válvula de pilotaje
4	3009504X1	2	M10 x 100	1	Screw	Vis	Tornillo
5	385362X1	2	M10	1	Washer	Rondelle	Arandela
6	1440329X1	2	M10	1	Nut, Lock	Écrou de blocage	Tuerca de retención
7	358743X91	2	3/4"	2	Union	Union	Unión
8		7	➡ Ref. 7	1	Union	Union	Unión
9	831497M1	7		1	O-Ring	Joint torique	Junta de tipo O
10	6109373M91	2		1	Tube Assy	Tuyauterie	Conjunto de tubería
11	3519179M91	2		1	Connector Assy	Ensemble connexion	Conexión, Conj.
12		11	➡ Ref. 11	1	Union	Union	Unión
13	831452M1	11		1	O-Ring	Joint torique	Junta de tipo O
14	6106193M92	2		1	Accumulator	Accumulateur	Acumulador
15	6101361M1	2		4	Bracket, Clamp	Bride de fixation	Brida de fijación
16	339337X1	2	M8 x 30	4	Bolt	Boulon	Perno
17	394367X1	2	M8	4	Nut, Lock	Écrou de blocage	Tuerca de retención
18	6108851M1	2		2	Decal	Adhésif	Adhesivo
19	255927A1	2	(GB)	1	Decal	Adhésif	Adhesivo
19	256464A1	2	(F)	1	Decal	Adhésif	Adhesivo
19	256465A1	2	(D)	1	Decal	Adhésif	Adhesivo
19	256468A1	2	(I)	1	Decal	Adhésif	Adhesivo
19	256467A1	2	(E)	1	Decal	Adhésif	Adhesivo
19	256474A1	2	(NL)	1	Decal	Adhésif	Adhesivo
19	256466A1	2	(DK)	1	Decal	Adhésif	Adhesivo
20	256318A1	2	(GB)	1	Decal	Adhésif	Adhesivo
20	256453A1	2	(F)	1	Decal	Adhésif	Adhesivo
20	256454A1	2	(D)	1	Decal	Adhésif	Adhesivo
20	256457A1	2	(I)	1	Decal	Adhésif	Adhesivo
20	256456A1	2	(E)	1	Decal	Adhésif	Adhesivo
20	256463A1	2	(NL)	1	Decal	Adhésif	Adhesivo
20	256455A1	2	(DK)	1	Decal	Adhésif	Adhesivo
21	6109375M91	2		1	Hose Assy	Ensemble de flexible	Flexible, Conj.
22	6109376M91	2		1	Connector Assy	Ensemble connexion	Conexión, Conj.
23		22	➡ Ref. 22	1	Connector	Connecteur	Conector
24	835026M1	22		1	O-Ring	Joint torique	Junta de tipo O
25	6109468M91	2		1	Hose Assy	Ensemble de flexible	Flexible, Conj.
26	360202X91	2		2	Union	Union	Unión
27		26	➡ Ref. 26	1	Union	Union	Unión
28	831497M1	26		1	O-Ring	Joint torique	Junta de tipo O
29	6110180M91	2		1	Hose Assy	Ensemble de flexible	Flexible, Conj.
30	6101777M91	2	Switch	1	Cover	Cache	Tapa
31	6102490M1	2		1	Relay	Relais	Relé
32	6109507M91	1		1	Switchpack	Paquet de commut.	Paquete de cambio



880
TX760B TX860B
TX870B

832 834 842 844 852 854

98130AC01.1

6199042M3

1

Jan-06

Ride Control
Circuit Hydraulique
Control anticabeceo

Hydraulic Circuit
Système Anti-Tangage
Circuito hidráulico

Rops
Rops
Rops

33	6101778M1	1	2	Cover	Cache	Tapa
----	-----------	---	---	-------	-------	------

AC-98130-01.1-A

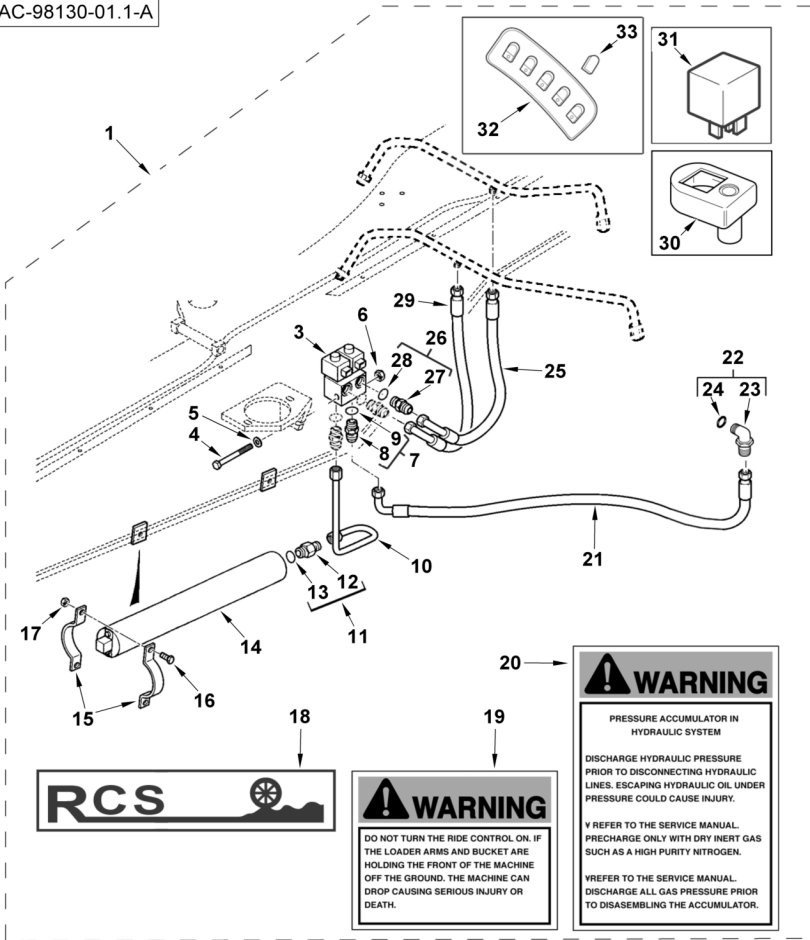

WARNING

PRESSURE ACCUMULATOR IN HYDRAULIC SYSTEM

DISCHARGE HYDRAULIC PRESSURE PRIOR TO DISCONNECTING HYDRAULIC LINES. ESCAPING HYDRAULIC OIL UNDER PRESSURE COULD CAUSE INJURY.

REFER TO THE SERVICE MANUAL. PRECHARGE ONLY WITH DRY INERT GAS SUCH AS A HIGH PURITY NITROGEN.

REFER TO THE SERVICE MANUAL. DISCHARGE ALL GAS PRESSURE PRIOR TO DISASSEMBLING THE ACCUMULATOR.

WARNING

DO NOT TURN THE RIDE CONTROL ON, IF THE LOADER ARMS AND BUCKET ARE HOLDING THE FRONT OF THE MACHINE OFF THE GROUND. THE MACHINE CAN DROP CAUSING SERIOUS INJURY OR DEATH.



880
TX760B TX860B
TX870B

832 834 842 844 852 854

Ride Control
Circuit Hydraulique
Control anticabeceo

Hydraulic Circuit
Système Anti-Tangage
Circuito hidráulico

Rops
Rops
Rops

C-98130-01.1-A

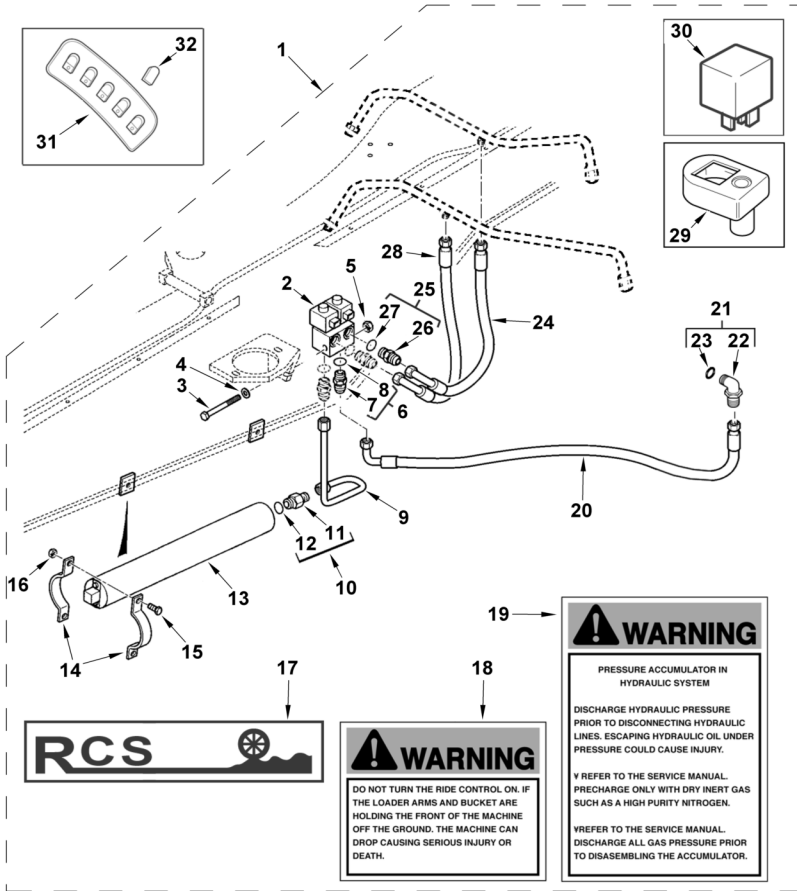

1	6109929M91			1	Ride Control	Système anti-tangage	Control anticabeceo
2	6100522M91	1		1	Valve, Pilot	Soupape de pilotage	Válvula de pilotaje
3	3009504X1	1	M10 x 100	1	Screw	Vis	Tornillo
4	385362X1	1	M10	1	Washer	Rondelle	Arandela
5	1440329X1	1	M10	1	Nut, Lock	Écrou de blocage	Tuerca de retención
6	358743X91	1	3/4"	2	Union	Union	Unión
7		6	➡ Ref. 6	1	Union	Union	Unión
8	831497M1	6		1	O-Ring	Joint torique	Junta de tipo O
9	6109373M91	1		1	Tube Assy	Tuyauterie	Conjunto de tubería
10	3519179M91	1		1	Connector Assy	Ensemble connexion	Conexión, Conj.
11		10	➡ Ref. 10	1	Union	Union	Unión
12	831452M1	10		1	O-Ring	Joint torique	Junta de tipo O
13	6106193M92	1		1	Accumulator	Accumulateur	Acumulador
14	6101361M1	1		4	Bracket, Clamp	Bride de fixation	Brida de fijación
15	339337X1	1	M8 x 30	4	Bolt	Boulon	Perno
16	394367X1	1	M8	4	Nut, Lock	Écrou de blocage	Tuerca de retención
17	6108851M1	1		2	Decal	Adhésif	Adhesivo
18	255927A1	1	(GB)	1	Decal	Adhésif	Adhesivo
18	256464A1	1	(F)	1	Decal	Adhésif	Adhesivo
18	256465A1	1	(D)	1	Decal	Adhésif	Adhesivo
18	256468A1	1	(I)	1	Decal	Adhésif	Adhesivo
18	256467A1	1	(E)	1	Decal	Adhésif	Adhesivo
18	256474A1	1	(NL)	1	Decal	Adhésif	Adhesivo
18	256466A1	1	(DK)	1	Decal	Adhésif	Adhesivo
19	256318A1	1	(GB)	1	Decal	Adhésif	Adhesivo
19	256453A1	1	(F)	1	Decal	Adhésif	Adhesivo
19	256454A1	1	(D)	1	Decal	Adhésif	Adhesivo
19	256457A1	1	(I)	1	Decal	Adhésif	Adhesivo
19	256456A1	1	(E)	1	Decal	Adhésif	Adhesivo
19	256463A1	1	(NL)	1	Decal	Adhésif	Adhesivo
19	256455A1	1	(DK)	1	Decal	Adhésif	Adhesivo
20	6109375M91	1		1	Hose Assy	Ensemble de flexible	Flexible, Conj.
21	6109376M91	1		1	Connector Assy	Ensemble connexion	Conexión, Conj.
22		21	➡ Ref. 21	1	Connector	Connecteur	Conector
23	835026M1	21		1	O-Ring	Joint torique	Junta de tipo O
24	6109468M91	1		1	Hose Assy	Ensemble de flexible	Flexible, Conj.
25	360202X91	1		2	Union	Union	Unión
26		25	➡ Ref. 25	1	Union	Union	Unión
27	831497M1	25		1	O-Ring	Joint torique	Junta de tipo O
28	6110180M91	1		1	Hose Assy	Ensemble de flexible	Flexible, Conj.
29	6101777M91	1	Switch	1	Cover	Cache	Tapa
30	6102490M1	1		1	Relay	Relais	Relé
31	6109507M91	1		1	Switchpack	Paquet de commut.	Paquete de cambio
32	6101778M1			2	Cover	Cache	Tapa



880
TX760B TX860B
TX870B

832 834 842 844 852 854

98130C01.1

6199042M3

1

Jan-06

Ride Control
Circuit Hydraulique
Control anticabeceo

Hydraulic Circuit
Système Anti-Tangage
Circuito hidráulico

Rops
Rops
Rops

C-98130-01.1-A

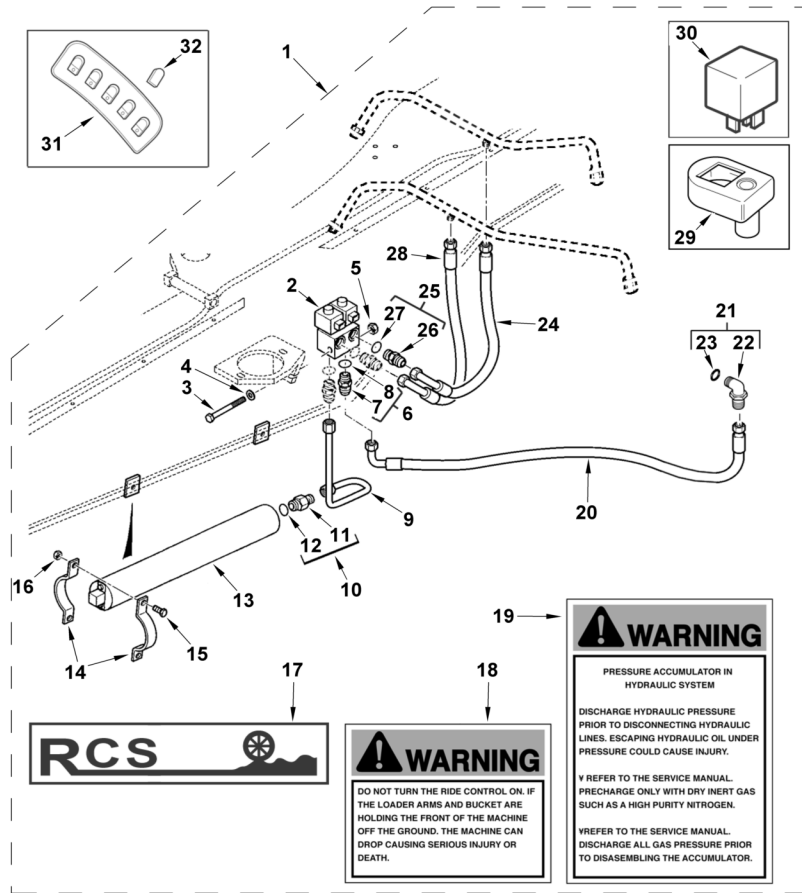

880
TX760B TX860B
TX870B

832 834 842 844 852 854

98130C01.1

6199042M3

1

Jan-06

Rockguard Kit
Coffret de Protection Vérin de Stabilisateur
Juego de protección de gato de estabilizador

C-98104-01.1-A

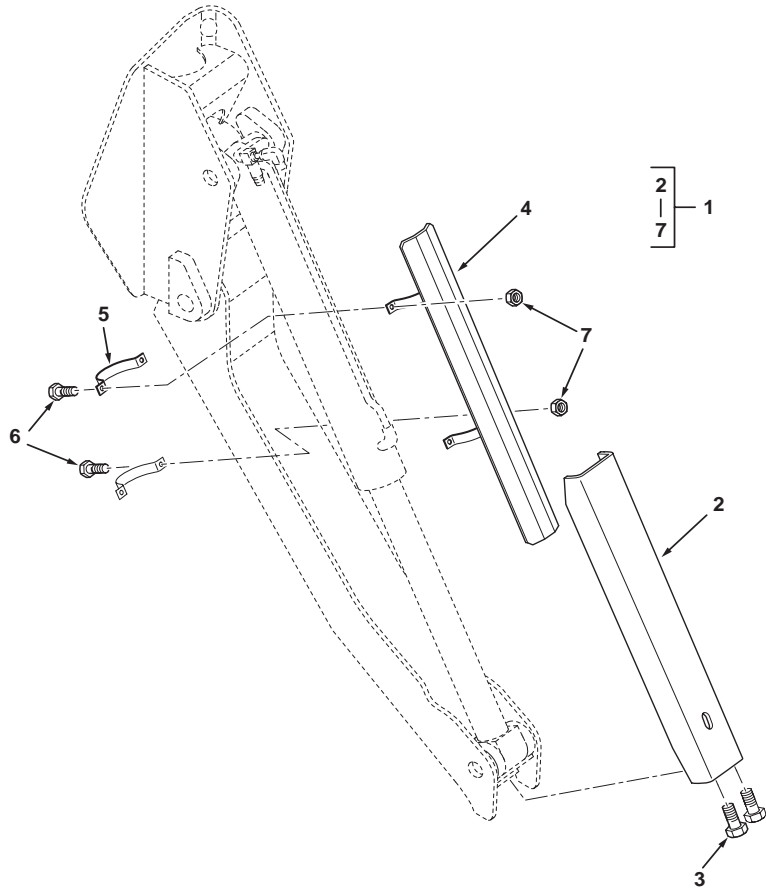

1	6107964M92			1	Guard Assy	Ensemble protection	Protector, Conj.
2	6107962M92	1		2	Protector	Protection	Protección
3	339081X1	1	M10 x 20	4	Screw	Vis	Tornillo
4	6107963M92	1		2	Guide	Guide	Guía
5	6108012M2	1		4	Clamp	Collier de serrage	Argolla de cierre
6	339761X1	1	M8 x 25	8	Screw	Vis	Tornillo
7	394367X1	1	M8	8	Nut, Lock	Écrou de blocage	Tuerca de retención



820 860 880 970 980
 TX760B TX860B
 TX870B TX970B

801 802 803 804 809 810 811 812 813 814 815 816 821 822 823 824 841 842 843
 844 851 852 853 854 922 923 932

98104C01.1

6199042M3

1

Jan-06

Rotating Beacon Kit
Coffret de Feu Intermittent
Juego de luz giratoria

Double
 Double
 Doble

AC-98015-01.1-A

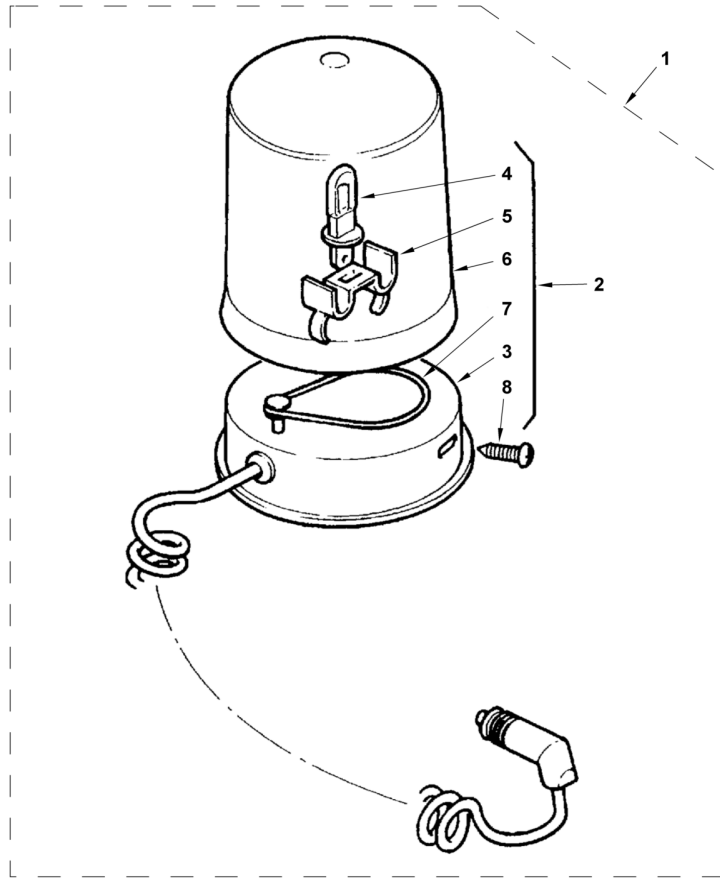

1	ACC02B		Beacon Kit Double	1	Accessory code	Code accessoire	Código accesorio
	3517622M91	1		2	Beacon, Rotating	Feu intermittent	Luz giratoria
2		2	Ref. 2	1	Base	Embase	Base
3	3523704M1	2	12V - 55W	1	Bulb	Lampe	Lámpara
4	6190229M1	2		1	Support	Support	Soporte
5	6190227M1	2		1	Lens	Lentille	Lente
6	6190228M1	2		1	Belt	Courroie	Correa
7	365915X1	2		1	Screw	Vis	Tornillo



820 860 880 970 980
 TX760B TX860B
 TX870B TX970B

801 803 805 807 813 815 817 821 823 825 831 833 841 843 845 851 853 855 921
 922 923 931 932

Rotating Beacon Kit
Coffret de Feu Intermittent
Juego de luz giratoria

Double
Double
Doble

C-98015-01.1-A

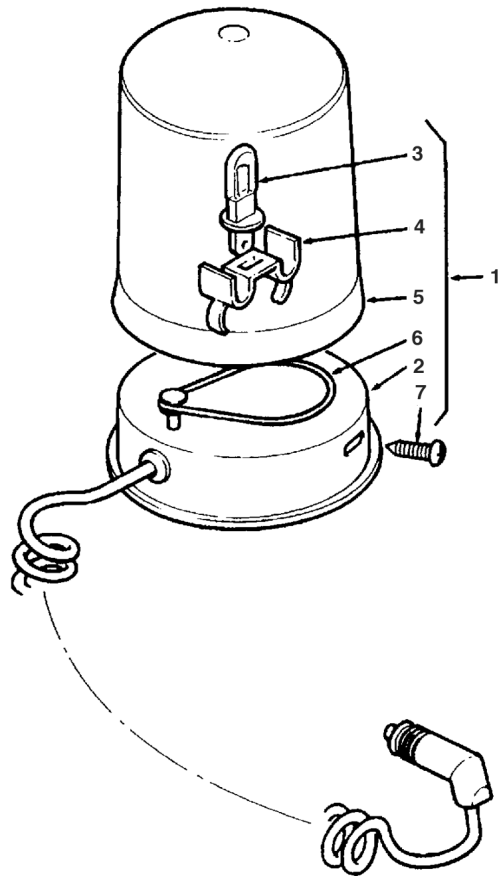

1	3517622M91			2	Beacon, Rotating	Feu intermittent	Luz giratoria
2		1	Ref. 1	1	Base	Embase	Base
3	3523704M1	1	12V - 55W	1	Bulb	Lampe	Lámpara
4	6190229M1	1		1	Support	Support	Soporte
5	6190227M1	1		1	Lens	Lentille	Lente
6	6190228M1	1		1	Belt	Courroie	Correa
7	365915X1	1		1	Screw	Vis	Tornillo



820 860 880 970 980
TX760B TX860B
TX870B TX970B

801 803 805 807 813 815 817 821 823 825 831 833 841 843 845 851 853 855 921
922 923 931 932

98015C01.1

6199042M3

1

Jan-06

Rotating Beacon Kit
Coffret de Feu Intermittent
Juego de luz giratoria

Single
 Simple
 Simple

AC-98016-01.1-A

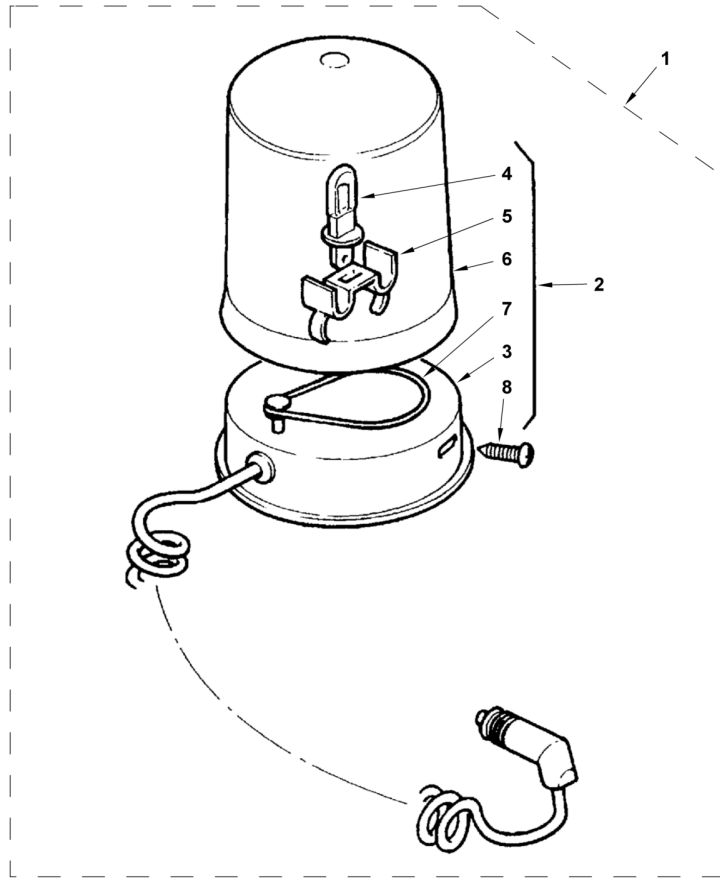

1	ACC02A		Beacon Kit Single	1	Accessory code	Code accessoire	Código accesorio
2	3517622M91	1		1	Beacon, Rotating	Feu intermittent	Luz giratoria
3		2	 Ref. 2	1	Base	Embase	Base
4	3523704M1	2	12V - 55W	1	Bulb	Lampe	Lámpara
5	6190229M1	2		1	Support	Support	Soporte
6	6190227M1	2		1	Lens	Lentille	Lente
7	6190228M1	2		1	Belt	Courroie	Correa
8	365915X1	2		1	Screw	Vis	Tornillo



820 860 880 970 980
 TX760B TX860B
 TX870B TX970B

801 803 805 807 809 811 813 815 817 821 823 825 831 833 841 843 845 851 853
 855 921 922 923 931 932

Rotating Beacon Kit
Coffret de Feu Intermittent
Juego de luz giratoria

Single
Simple
Simple

C-98016-01.1-A

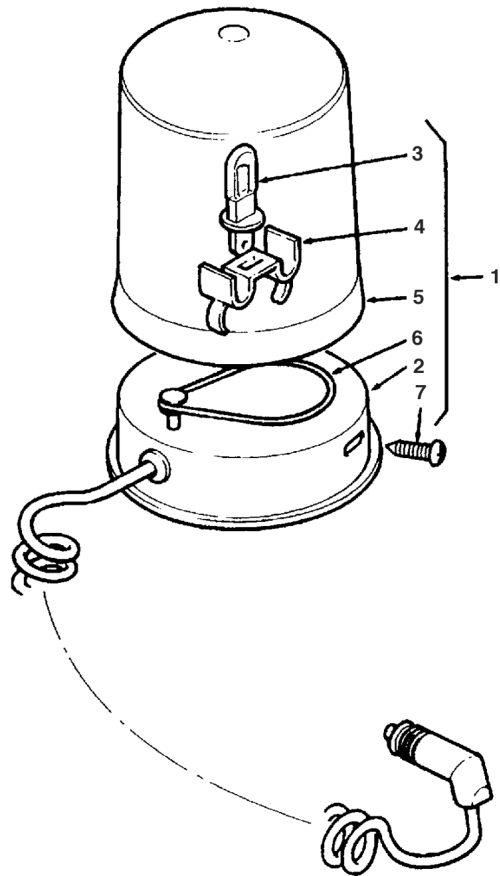

1	3517622M91			1	Beacon, Rotating	Feu intermittent	Luz giratoria
2		1	Ref. 1	1	Base	Embase	Base
3	3523704M1	1	12V - 55W	1	Bulb	Lampe	Lámpara
4	6190229M1	1		1	Support	Support	Soporte
5	6190227M1	1		1	Lens	Lentille	Lente
6	6190228M1	1		1	Belt	Courroie	Correa
7	365915X1	1		1	Screw	Vis	Tornillo



820 860 880 970 980
TX760B TX860B
TX870B TX970B

801 803 805 807 809 811 813 815 817 821 823 825 831 833 841 843 845 851 853
855 921 922 923 931 932

98016C01.1

6199042M3

1

Jan-06

Seat Armrest Kit
Coffret de Accoudoir de Siège
Juego de apoyabrazos de asiento

AC-98017-01.1-A

1	ACC04A			1	Accessory code	Code accessoire	Código accesorio
2	6102822M93	1		1	Kit, Armrest	Jeu d'accoudoirs	Juego de apoyabrazos
3	6102814M92	2		1	Armrest	Accoudoir	Apoyabrazos
4	6102815M92	2		1	Armrest	Accoudoir	Apoyabrazos
5	6102829M1	2		4	Screw	Vis	Tornillo
6	6107425M1	2		4	Spacer	Entretoise	Travesa

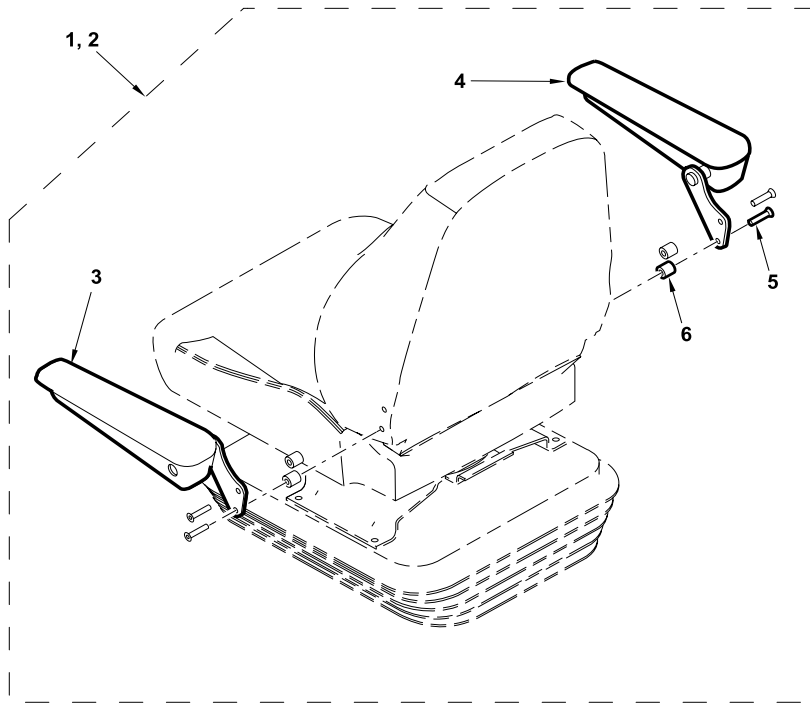

820 860 880 970 980
 TX760B TX860B
 TX870B TX970B

801 802 803 804 805 806 807 808 809 810 811 812 813 814 815 816 817 821 822
 823 824 825 831 832 833 834 841 842 843 844 845 851 852 853 854 855 921 922
 923 931 932

98017AC01.1

6199042M3

1

Jan-06

Seat Armrest Kit
Coffret de Accoudoir de Siège
Juego de apoyabrazos de asiento

C-98017-01.1-A

1	6102822M93			1	Kit, Armrest	Jeu d'accoudoirs	Juego de apoyabrazos
2	6102814M92	1		1	Armrest	Accoudoir	Apoyabrazos
3	6102815M92	1		1	Armrest	Accoudoir	Apoyabrazos
4	6102829M1	1		4	Screw	Vis	Tornillo
5	6107425M1	1		4	Spacer	Entretoise	Travesa

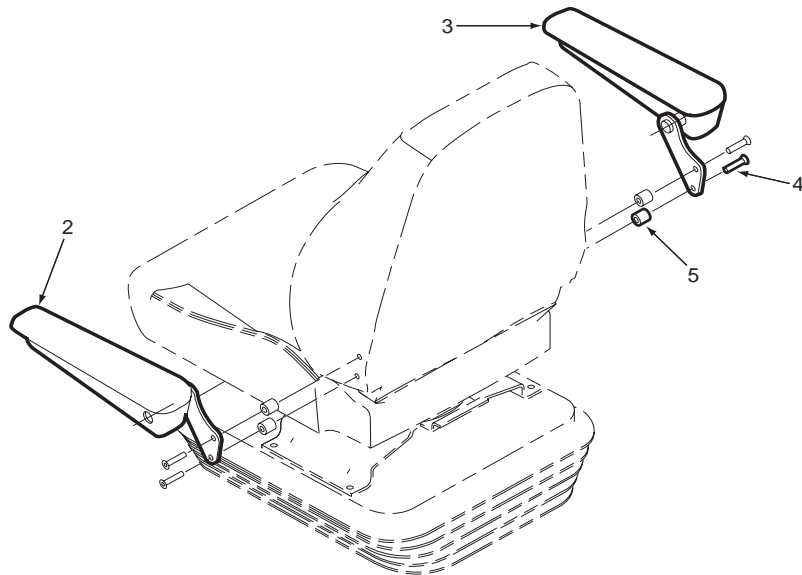

820 860 880 970 980
 TX760B TX860B
 TX870B TX970B

801 802 803 804 805 806 807 808 809 810 811 812 813 814 815 816 817 821 822
 823 824 825 831 832 833 834 841 842 843 844 845 851 852 853 854 855 921 922
 923 931 932

Seat Belt Kit
Coffret de Ceinture de Siège
Juego de cinturón de asiento

C-95022-01.1-A

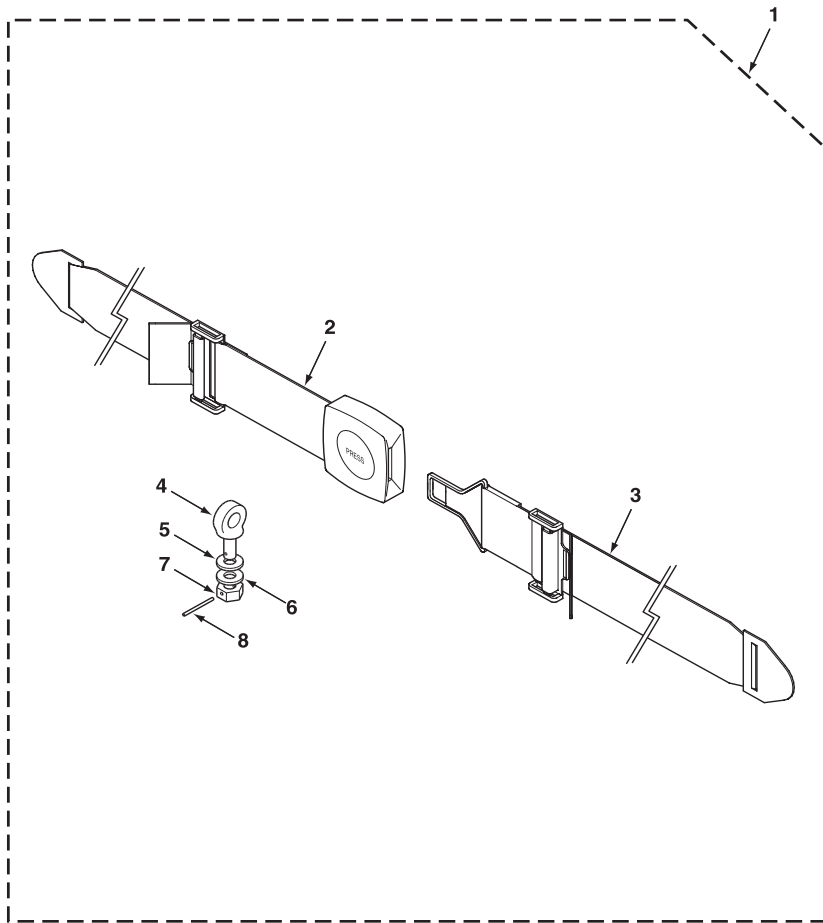

1	709093M91			1	Belt, Seat	Ceinture de sécurité	Cinturón, Seguridad
2		1	▶ Ref 1	1	Belt, Seat	Ceinture de sécurité	Cinturón, Seguridad
3		1	▶ Ref 1	1	Belt, Seat	Ceinture de sécurité	Cinturón, Seguridad
4	709403M1	1		2	Eyebolt	Boulon à œil	Perno de anilla
5	353432X1	1	7/16"	2	Washer	Rondelle	Arandela
6	369968X1	1		2	Washer, Special	Rondelle spéciale	Arandela especial
7	364201X1	1	7/16"-20 UNF	2	Nut	Écrou	Tuerca
8	354048X1	1	3/32" x 3/4"	2	Pin, Cotter	Goupille fendue	Pasador hendido



820 860 880 970 980
 TX760B TX860B
 TX870B TX970B

801 802 803 804 805 806 807 808 809 810 811 812 813 814 815 816 817 821 822
 823 824 825 831 832 833 834 841 842 843 844 845 851 852 853 854 855 921 922
 923 931 932

95022C01.1

6199042M3

1

Jan-06

Service Tool Kit
Coffret de Outillage d'entretien
Juego de herramientas de servicio

C-98019-01.1-A

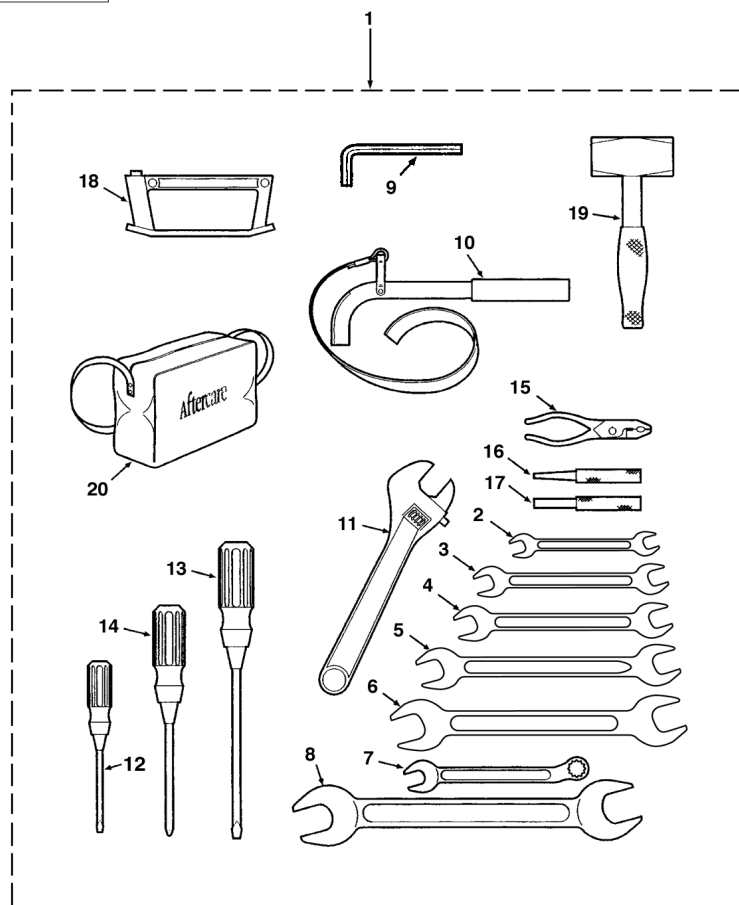

1	3621190M92		1	Kit, Tool	Kit d'outillage	Herramientas
2	1	10 x 11mm Ref. 1	1	Spanner	Clé	Llave inglesa
3	1	12 x 13mm Ref. 1	1	Spanner	Clé	Llave inglesa
4	1	14 x 15mm Ref. 1	1	Spanner	Clé	Llave inglesa
5	1	16 x 17mm Ref. 1	1	Spanner	Clé	Llave inglesa
6	1	18 x 19mm Ref. 1	1	Spanner	Clé	Llave inglesa
7	1	13mm Ref. 1	1	Spanner	Clé	Llave inglesa
8	1	24 x 27mm Ref. 1	1	Spanner	Clé	Llave inglesa
9	1	Ref. 1	1	Allen Key	Clé Allen	Llave Allen
10	1	24 x 27mm Ref. 1	1	Wrench	Clé	Llave
11	1	Adjustable Ref. 1	1	Spanner	Clé	Llave inglesa
12	1	Flat Ref. 1	1	Screwdriver	Tournevis	Destornillador
13	1	Flat Ref. 1	1	Screwdriver	Tournevis	Destornillador
14	1	Cross head Ref. 1	1	Screwdriver	Tournevis	Destornillador
15	1	Ref. 1	1	Pliers	Pinces	Alicates
16	1	Taper Ref. 1	1	Drift	Dérive	Deriva
17	1	Parallel Ref. 1	1	Drift	Dérive	Deriva
18	1	Ref. 1	1	Fuse remover	Dispositif ôter fus.	Quitafusibles
19	1	Ref. 1	1	Hammer	Marteau	Martillo
20	1	Ref. 1	1	Bag, Tool	Trousse à outils	Bolsa de herramientas



820 860 880 970 980
 TX760B TX860B
 TX870B TX970B

801 802 803 804 805 806 807 808 813 814 815 816 817 821 822 823 824 825 831
 832 833 834 841 842 843 844 845 851 852 853 854 855 921 922 923 931 932

98019C01.1

6199042M3

1

Jan-06

Service Tool Kit
Coffret de Outillage d'entretien
Juego de herramientas de servicio

Clamp
Collier
Abrazadera

C-98109-01.1-A

1	6108689M1		1	Clamp	Collier de serrage	Argolla de cierre
---	-----------	--	---	-------	--------------------	-------------------

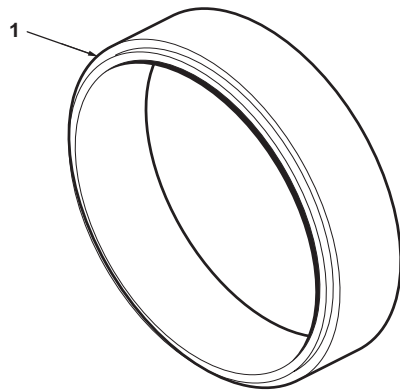

820 860 880 970 980
TX760B TX860B

805 806 807 808 817 825 845 855 921 931

98109C01.1

6199042M3

1

Jan-06

Spare Wheels - Front (M03 & M10)

C-98139-01.1-A

1	6109026M91Y 02	(A)	1	Wheel Assy	Ensemble de roue	Rueda, Conj.
2	6109027M91Y 02	1	13 x 20	Wheel	Roue	Rueda
3	6109838M1	1	16/70 x 20 10P R4	Tyre	Pneumatique	Neumático
4	842537M1	1		Valve Stem	Valve de gonflage	Válvula de inflado

A Not serviced - order details
 Non fourni - commander détails
 No suministradas - pedir detalles

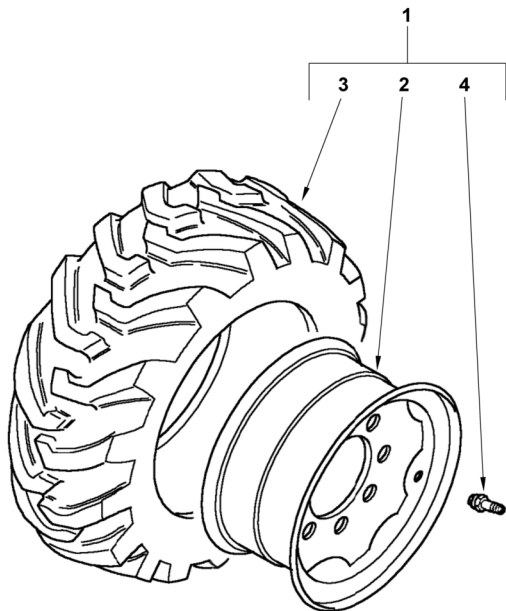

880
TX860B TX870B

841 842 843 844 845 851 852 853 854

Spare Wheels - Front (M03 & M10)

C-98150-01.1-A

1	6109026M91 W01	(A)	1	Wheel Assy	Ensemble de roue	Rueda, Conj.
2	6109027M91 W01	1 13 x 20	1	Wheel	Roue	Rueda
3	6109838M1	1 16/70 x 20 10P R4	1	Tyre	Pneumatique	Neumático
4	842537M1	1	1	Valve Stem	Valve de gonflage	Válvula de inflado

A Not serviced - order details
 Non fourni - commander détails
 No suministradas - pedir detalles

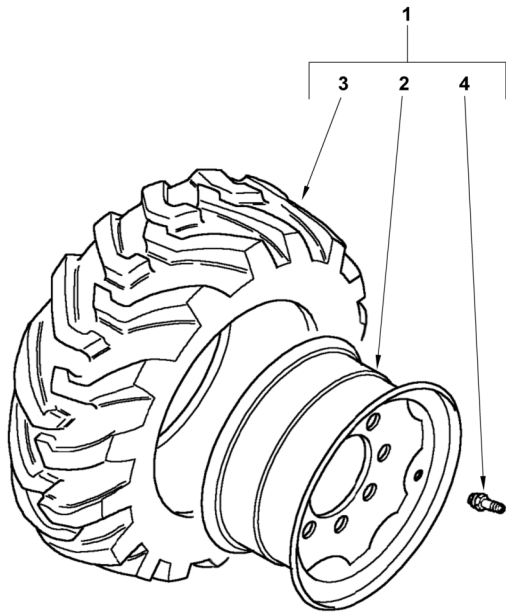

880
TX860B TX870B

841 842 843 844 845 851 852 853 854

Spare Wheels - Front (M04)

C-98140-01.1-A

1	6109579M91Y 02	(A)	1	Wheel Assy	Ensemble de roue	Rueda, Conj.
2	6109030M91Y 02	1 11 x 18	1	Wheel	Roue	Rueda
3	6109462M1	1 12.5/80 x 18 12PLY R4	1	Tyre	Pneumatique	Neumático
4	842537M1	1	1	Valve Stem	Valve de gonflage	Válvula de inflado

A Not serviced - order details
 Non fourni - commander détails
 No suministradas - pedir detalles

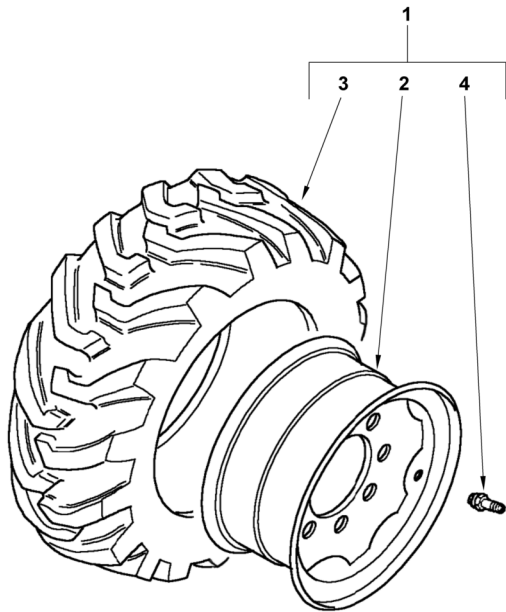

880
TX860B TX870B

841 842 843 844 851 852 853 854

Spare Wheels - Front (M04)

C-98151-01.1-A

1	6109579M91 W01	(A)	1	Wheel Assy	Ensemble de roue	Rueda, Conj.
2	6109030M91 W01	1 11 x 18	1	Wheel	Roue	Rueda
3	6109462M1	1 12.5/80 x 18 12PLY R4	1	Tyre	Pneumatique	Neumático
4	842537M1	1	1	Valve Stem	Valve de gonflage	Válvula de inflado

A Not serviced - order details
 Non fourni - commander détails
 No suministradas - pedir detalles

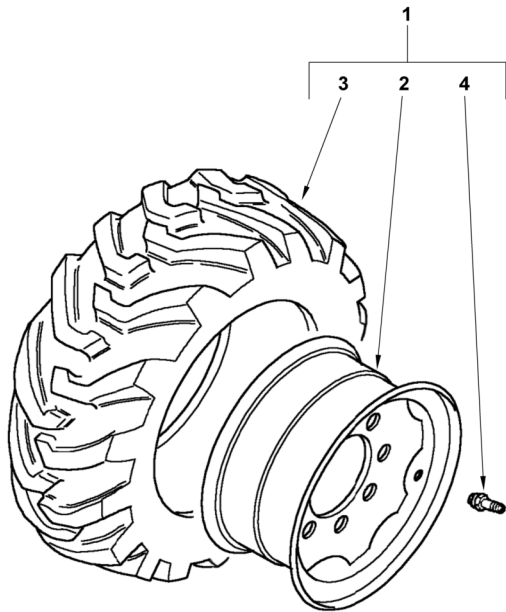

880
TX860B TX870B

841 842 843 844 851 852 853 854

Spare Wheels - Front (M09)

C-98143-01.1-A

1	6109581M91Y 02	(A)	1	Wheel Assy	Ensemble de roue	Rueda, Conj.
2	6109027M91Y 02	1	13 x 20	Wheel	Roue	Rueda
3	6109842M1	1	16/70 x 20 10P R1	Tyre	Pneumatique	Neumático
4	842537M1	1		Valve Stem	Valve de gonflage	Válvula de inflado

A Not serviced - order details
 Non fourni - commander détails
 No suministradas - pedir detalles

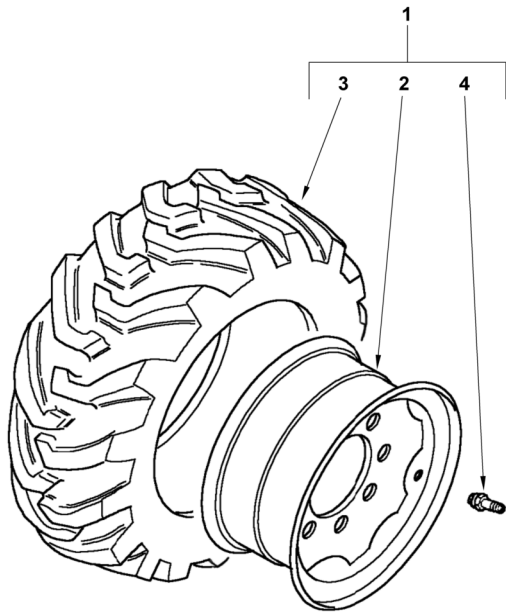

880
TX860B TX870B

841 842 843 844 845 851 852 853 854 855

Spare Wheels - Front (M09)

C-98154-01.1-A

1	6109581M91 W01	(A)	1	Wheel Assy	Ensemble de roue	Rueda, Conj.
2	6109027M91Y 02	1	13 x 20	Wheel	Roue	Rueda
3	6109842M1	1	16/70 x 20 10P R1	Tyre	Pneumatique	Neumático
4	842537M1	1		Valve Stem	Valve de gonflage	Válvula de inflado

A Not serviced - order details
 Non fourni - commander détails
 No suministradas - pedir detalles

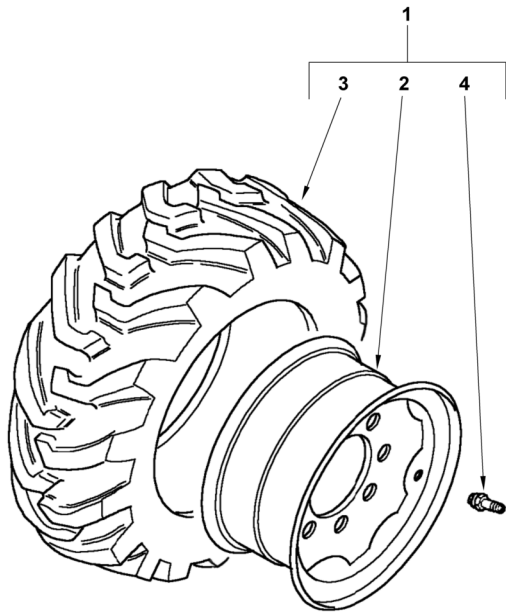

880
TX860B TX870B

841 842 843 844 845 851 852 853 854 855

Spare Wheels - Front (M20 & M22)

C-98147-01.1-A

1	6110519M91Y 02	(A)	1	Wheel Assy	Ensemble de roue	Rueda, Conj.
2	6109027M91Y 02	1 13 x 20	1	Wheel	Roue	Rueda
3	3520466M2	1	1	Tyre	Pneumatique	Neumático
4	842537M1	1	1	Valve Stem	Valve de gonflage	Válvula de inflado

A Not serviced - order details
 Non fourni - commander détails
 No suministradas - pedir detalles

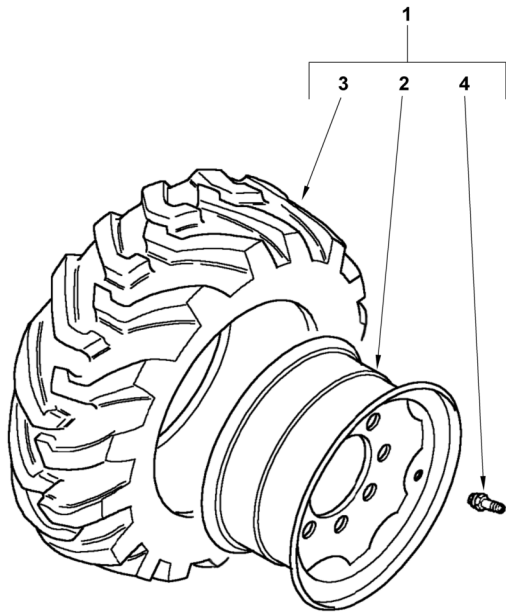

880
TX860B TX870B

841 842 843 844 845 851 852 853 854 855

Spare Wheels - Front (M20 & M22)

C-98158-01.1-A

1	6110519M91 W01	(A)	1	Wheel Assy	Ensemble de roue	Rueda, Conj.
2	6109027M91 W01	1 13 x 20	1	Wheel	Roue	Rueda
3	3520466M2	1	1	Tyre	Pneumatique	Neumático
4	842537M1	1	1	Valve Stem	Valve de gonflage	Válvula de inflado

A Not serviced - order details
 Non fourni - commander détails
 No suministradas - pedir detalles

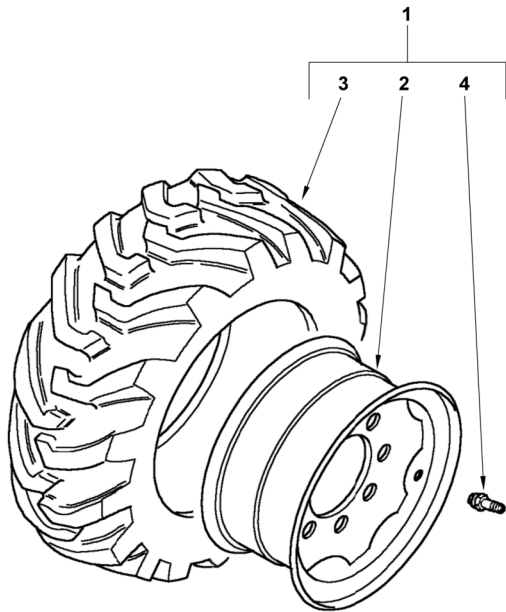

880
TX860B TX870B

841 842 843 844 845 851 852 853 854 855

Spare Wheels - Front (M21)

C-98148-01.1-A

1	6110584M91Y 02	(A)	1	Wheel Assy	Ensemble de roue	Rueda, Conj.
2	6109027M91Y 02	1 13 x 20	1	Wheel	Roue	Rueda
3	3520467M1	1	1	Tyre	Pneumatique	Neumático
4	842537M1	1	1	Valve Stem	Valve de gonflage	Válvula de inflado

A Not serviced - order details
 Non fourni - commander détails
 No suministradas - pedir detalles

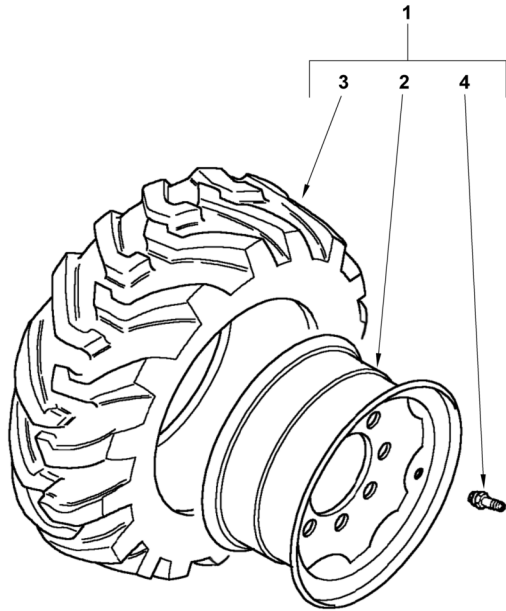

880
TX860B TX870B

841 842 843 844 845 851 852 853 854 855

Spare Wheels - Front (M21)

C-98159-01.1-A

1	6110584M91 W01	(A)	1	Wheel Assy	Ensemble de roue	Rueda, Conj.
2	6109027M91 W01	1 13 x 20	1	Wheel	Roue	Rueda
3	3520467M1	1	1	Tyre	Pneumatique	Neumático
4	842537M1	1	1	Valve Stem	Valve de gonflage	Válvula de inflado

A Not serviced - order details
 Non fourni - commander détails
 No suministradas - pedir detalles

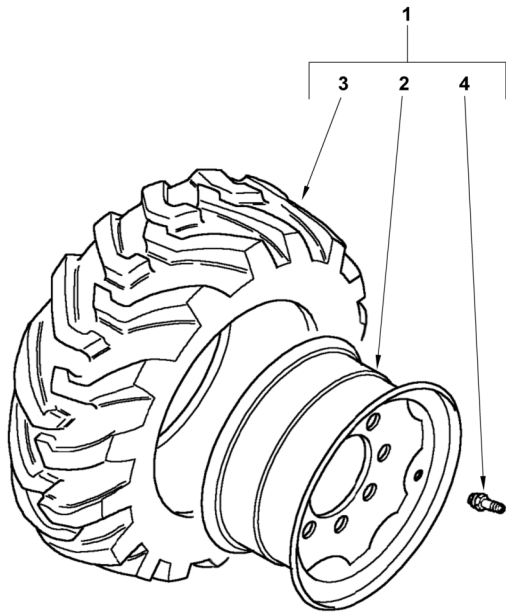

880
TX860B TX870B

841 842 843 844 845 851 852 853 854 855

Spare Wheels - Rear (M01 & M04)

C-98165-01.1-A

1	6109464M91Y02	(A)	1	Wheel Assy	Ensemble de roue	Rueda, Conj.
2	6103185M91	1 W15L	1	Rim, Wheel	Jante	Llanta
3	6109465M1	1 19.5L x 24 12PLY R4	1	Tyre	Pneumatique	Neumático
4	842537M1	1	1	Valve Stem	Valve de gonflage	Válvula de inflado

A Not serviced - order details
 Non fourni - commander détails
 No suministradas - pedir detalles

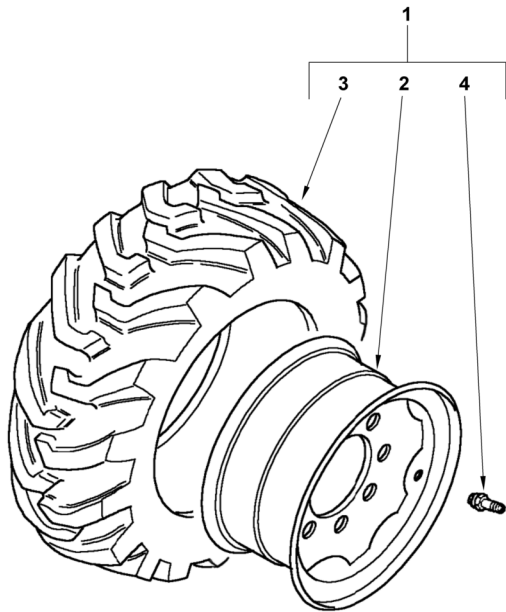

880
 TX860B TX870B

841 842 843 844

Spare Wheels - Rear (M01 & M04)

C-98177-01.1-A

1	6109464M91 W01	(A)	1	Wheel Assy	Ensemble de roue	Rueda, Conj.
2	6103185M91	1 W15L	1	Rim, Wheel	Jante	Llanta
3	6109465M1	1 19.5L x 24 12PLY R4	1	Tyre	Pneumatique	Neumático
4	842537M1	1	1	Valve Stem	Valve de gonflage	Válvula de inflado

A Not serviced - order details
 Non fourni - commander détails
 No suministradas - pedir detalles

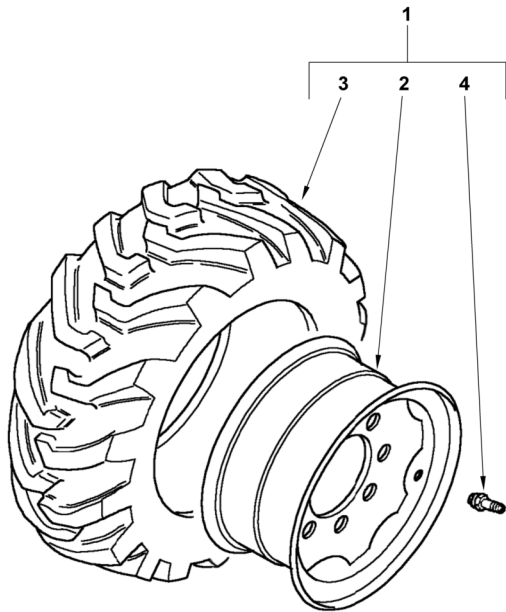

880
TX860B TX870B

841 842 843 844

Spare Wheels - Rear (M03 & M13)

C-98164-01.1-A

1	6103254M92Y 02	(A)	1	Wheel Assy	Ensemble de roue	Rueda, Conj.
2	6103191M91	1 DW15L	1	Rim, Wheel	Jante	Llanta
3	6109841M1	1 16.9 x 30 14P	1	Tyre	Pneumatique	Neumático
4	892595M1	1	1	Tube, Air	Chambre à air	Cámara de aire

A Not serviced - order details
 Non fourni - commander détails
 No suministradas - pedir detalles

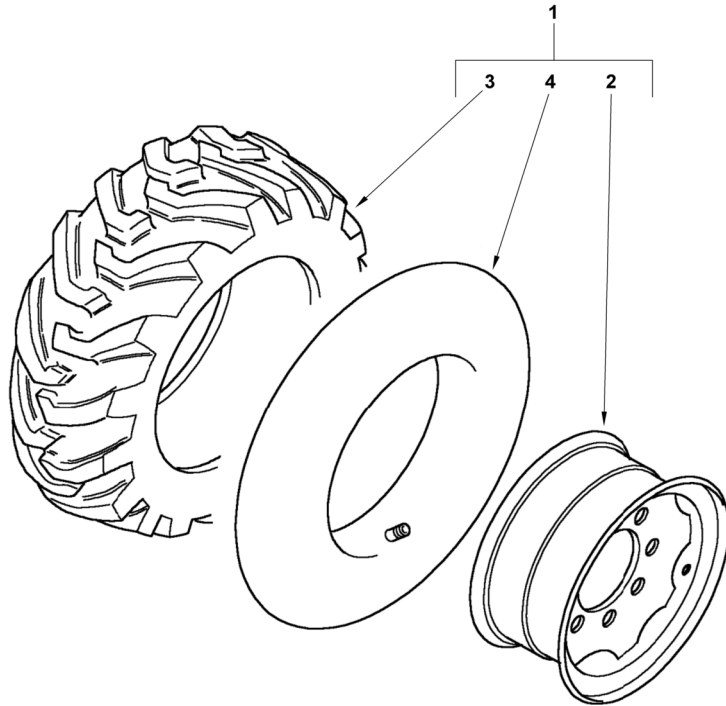

880
TX860B TX870B

841 842 843 844 845 851 852 853 854 855

Spare Wheels - Rear (M03 & M13)

C-98176-01.1-A

1	6103254M92 W01		(A)	1	Wheel Assy	Ensemble de roue	Rueda, Conj.
2	6103191M91	1	DW15L	1	Rim, Wheel	Jante	Llanta
3	6109841M1	1	16.9 x 30 14P	1	Tyre	Pneumatique	Neumático
4	892595M1	1		1	Tube, Air	Chambre à air	Cámara de aire

A Not serviced - order details
 Non fourni - commander détails
 No suministradas - pedir detalles

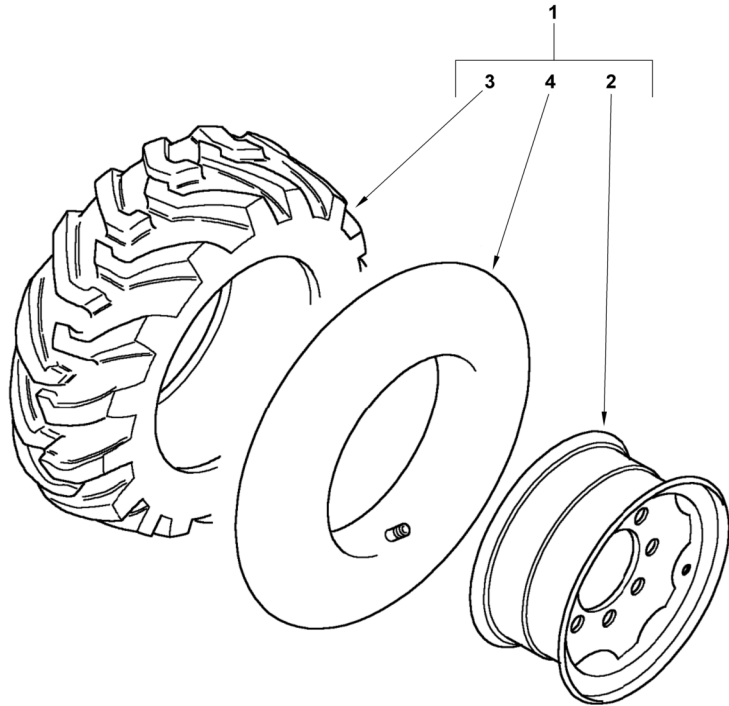

880
TX860B TX870B

841 842 843 844 845 851 852 853 854 855

Spare Wheels - Rear (M05, M09, M14 & M21)

C-98162-01.1-A

1	6103246M92Y 02	(A)	1	Wheel Assy	Ensemble de roue	Rueda, Conj.
2	6103187M91	1 DW16L	1	Rim, Wheel	Jante	Llanta
3	6109736M1	1 18.4 x 26 R1	1	Tyre	Pneumatique	Neumático
4	1474020M1	1	1	Tube, Air	Chambre à air	Cámara de aire

A Not serviced - order details
 Non fourni - commander détails
 No suministradas - pedir detalles

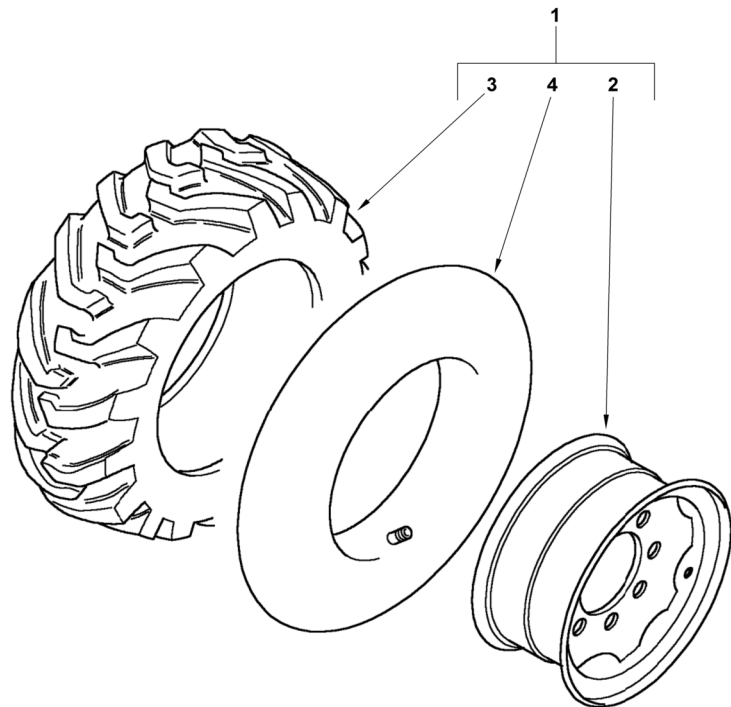

880
TX860B TX870B

841 842 843 844 845 851 852 853 854 855

Spare Wheels - Rear (M05, M09, M14 & M21)

C-98174-01.1-A

1	6103246M92Y 02	(A)	1	Wheel Assy	Ensemble de roue	Rueda, Conj.
2	6103187M91	1 DW16L	1	Rim, Wheel	Jante	Llanta
3	6109736M1	1 18.4 x 26 R1	1	Tyre	Pneumatique	Neumático
4	1474020M1	1	1	Tube, Air	Chambre à air	Cámara de aire

A Not serviced - order details
 Non fourni - commander détails
 No suministradas - pedir detalles

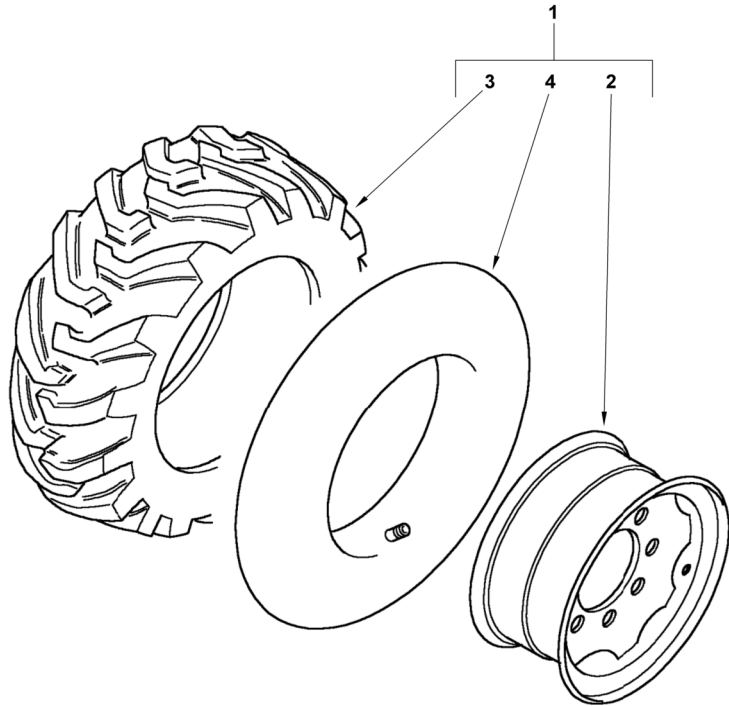

880
TX860B TX870B

841 842 843 844 845 851 852 853 854 855

Spare Wheels - Rear (M07, M10 & M12)

C-98161-01.1-A

1	6103250M92Y 02	(A)	1	Wheel Assy	Ensemble de roue	Rueda, Conj.
2	6103191M91	1 DW15L	1	Rim, Wheel	Jante	Llanta
3	6109839M1	1 16.9 x 30 10P	1	Tyre	Pneumatique	Neumático
4	842537M1	1	1	Valve Stem	Valve de gonflage	Válvula de inflado

A Not serviced - order details
 Non fourni - commander détails
 No suministradas - pedir detalles

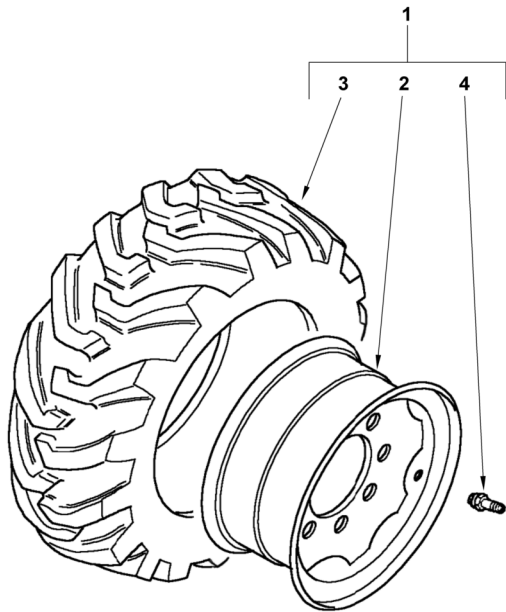

880
TX860B TX870B

841 842 843 844 845 851 852 853 854 855

Spare Wheels - Rear (M07, M10 & M12)

C-98173-01.1-A

1	6103250M92 W01		(A)	1	Wheel Assy	Ensemble de roue	Rueda, Conj.
2	6103191M91	1	DW15L	1	Rim, Wheel	Jante	Llanta
3	6109839M1	1	16.9 x 30 10P	1	Tyre	Pneumatique	Neumático
4	842537M1	1		1	Valve Stem	Valve de gonflage	Válvula de inflado

A Not serviced - order details
 Non fourni - commander détails
 No suministradas - pedir detalles

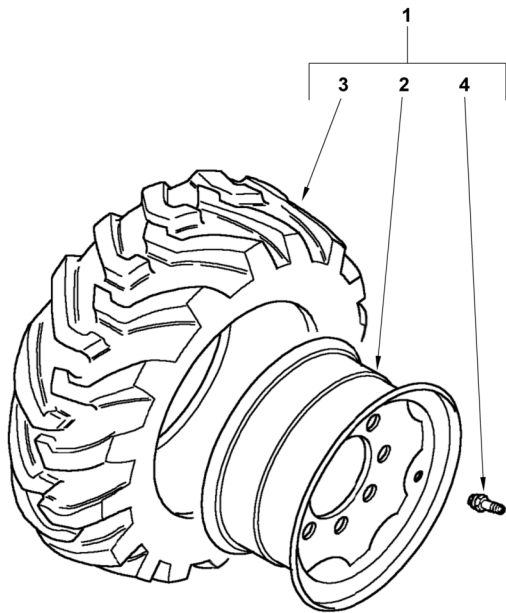

880
TX860B TX870B

841 842 843 844 845 851 852 853 854 855

Spare Wheels - Rear (M15)

C-98166-01.1-A

1	6108063M91Y 02	(A)	1	Wheel Assy	Ensemble de roue	Rueda, Conj.
2	6103183M91Y 02	1 W15L	1	Rim, Wheel	Jante	Llanta
3	3517779M2	1 24 - 16.9 12P R4	1	Tyre	Pneumatique	Neumático
4	842537M1	1	1	Valve Stem	Valve de gonflage	Válvula de inflado

A Not serviced - order details
 Non fourni - commander détails
 No suministradas - pedir detalles

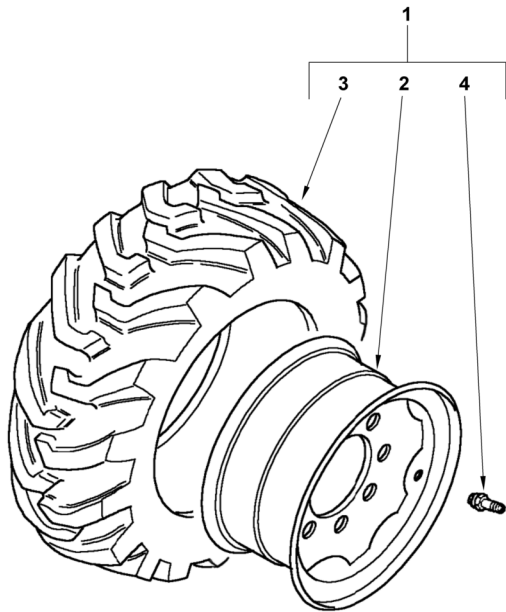

980
TX970B

931 932

98166C01.1

6199042M3

1

Jan-06

Spare Wheels - Rear (M15)

C-98178-01.1-A

1	6108063M91 W01	(A)	1	Wheel Assy	Ensemble de roue	Rueda, Conj.
2	6103183M91 W01	1 W15L	1	Rim, Wheel	Jante	Llanta
3	3517779M2	1 24 - 16.9 12P R4	1	Tyre	Pneumatique	Neumático
4	842537M1	1	1	Valve Stem	Valve de gonflage	Válvula de inflado

A Not serviced - order details
 Non fourni - commander détails
 No suministradas - pedir detalles

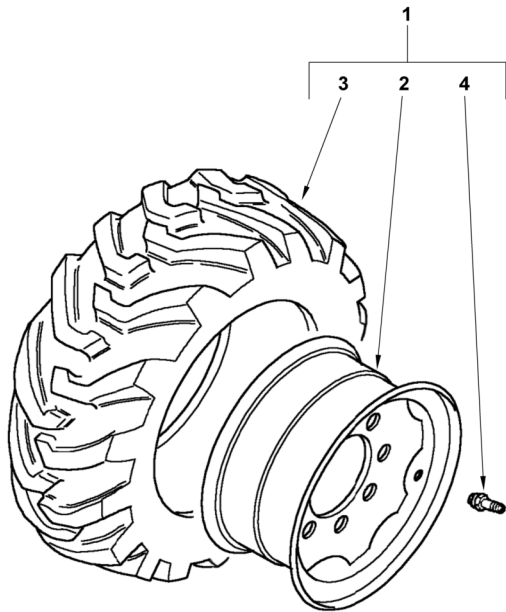

980
TX970B

931 932

98178C01.1

6199042M3

1

Jan-06

Spare Wheels - Rear (M16)

C-98167-01.1-A

1	6108065M91Y 02	(A)	2	Wheel Assy	Ensemble de roue	Rueda, Conj.
2	6103183M91Y 02	1 W15L	1	Rim, Wheel	Jante	Llanta
3	6106242M1	1 16.9 R24	1	Tyre	Pneumatique	Neumático
4	842537M1	1	1	Valve Stem	Valve de gonflage	Válvula de inflado

A Not serviced - order details
 Non fourni - commander détails
 No suministradas - pedir detalles

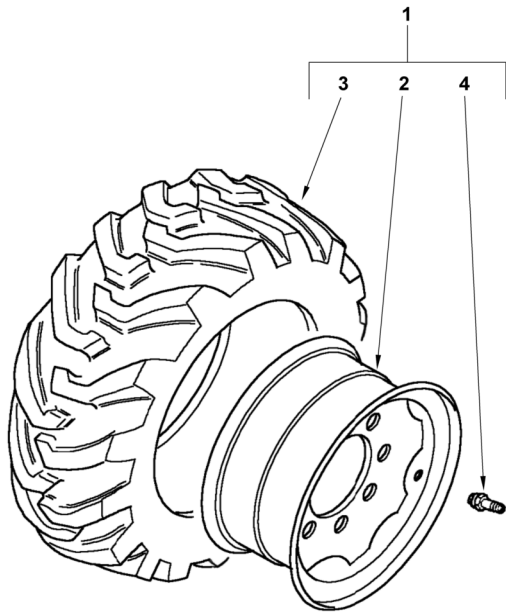

980
TX970B

931 932

98167C01.1

6199042M3

1

Jan-06

Spare Wheels - Rear (M16)

C-98179-01.1-A

1	6108065M91 W01	(A)	2	Wheel Assy	Ensemble de roue	Rueda, Conj.
2	6103183M91 W01	1 W15L	1	Rim, Wheel	Jante	Llanta
3	6106242M1	1 16.9 R24	1	Tyre	Pneumatique	Neumático
4	842537M1	1	1	Valve Stem	Valve de gonflage	Válvula de inflado

A Not serviced - order details
 Non fourni - commander détails
 No suministradas - pedir detalles

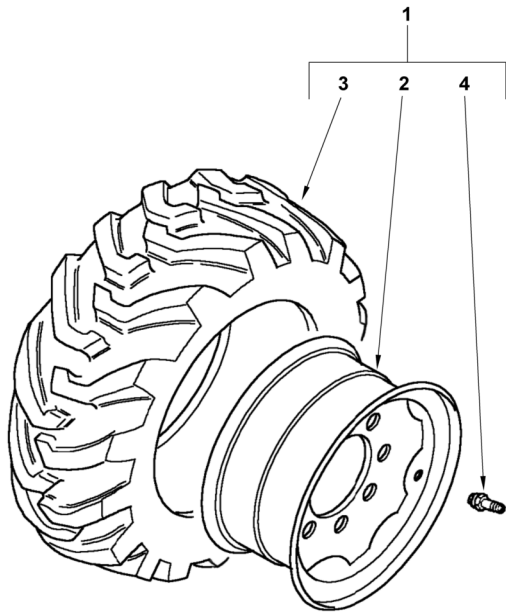

980
TX970B

931 932

98179C01.1

6199042M3

1

Jan-06

Spare Wheels - Rear (M17)

C-98168-01.1-A

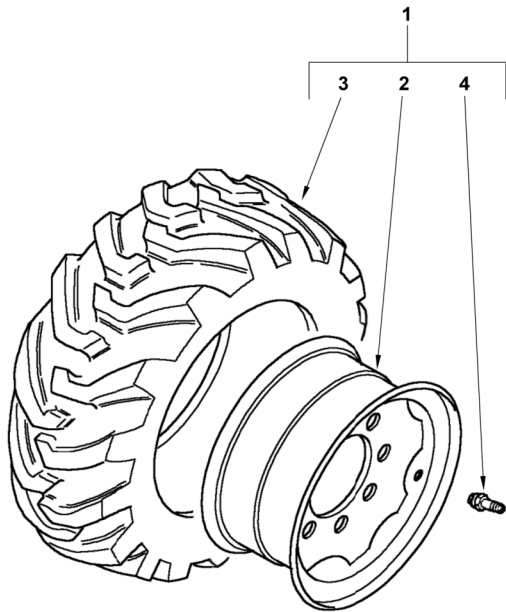

1	6108067M91Y 02	(A)	1	Wheel Assy	Ensemble de roue	Rueda, Conj.
2	6103183M91Y 02	1 W15L	1	Rim, Wheel	Jante	Llanta
3	6100225M1	1 17.5 LR24 x M27 TL146	1	Tyre	Pneumatique	Neumático
4	842537M1	1	1	Valve Stem	Valve de gonflage	Válvula de inflado

A Not serviced - order details
 Non fourni - commander détails
 No suministradas - pedir detalles



880 980
 TX860B TX970B

845 931 932

Spare Wheels - Rear (M20)

C-98170-01.1-A

1	6110523M91Y 02		(A)	1	Wheel Assy	Ensemble de roue	Rueda, Conj.
2	6103191M91Y 02	1		1	Rim, Wheel	Jante	Llanta
3	1456812M1	1		1	Tyre	Pneumatique	Neumático
4	842537M1	1		1	Valve Stem	Valve de gonflage	Válvula de inflado

A Not serviced - order details
 Non fourni - commander détails
 No suministradas - pedir detalles

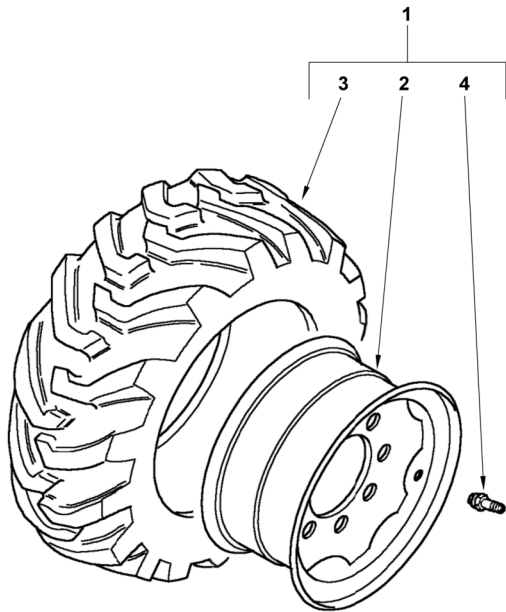

880
TX860B TX870B

841 842 843 844 851 852 853 854 855

Spare Wheels - Rear (M22)

C-98171-01.1-A

1	6110589M91Y 02		(A)	1	Wheel Assy	Ensemble de roue	Rueda, Conj.
2	6103191M91Y 02	1		1	Rim, Wheel	Jante	Llanta
3	1462951M1	1		1	Tyre	Pneumatique	Neumático
4	842537M1	1		1	Valve Stem	Valve de gonflage	Válvula de inflado

A Not serviced - order details
 Non fourni - commander détails
 No suministradas - pedir detalles

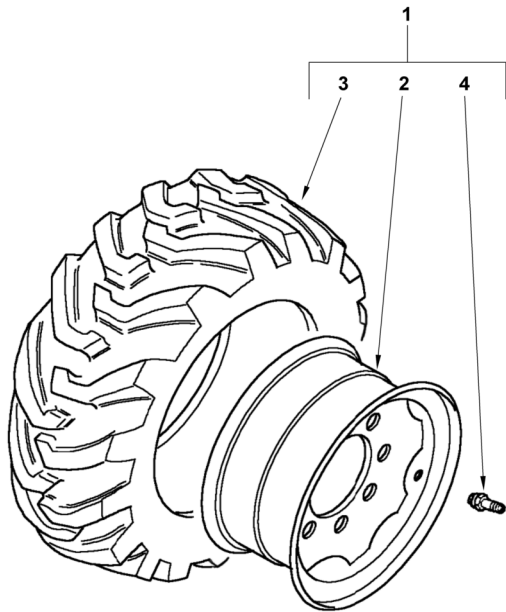

880
TX860B TX870B

841 842 843 844 845 851 852 853 854 855

Spare Wheels - Rear (M22)

C-98183-01.1-A

1	6110589M91 W01		(A)	1	Wheel Assy	Ensemble de roue	Rueda, Conj.
2	6103191M91 W01	1		1	Rim, Wheel	Jante	Llanta
3	1462951M1	1		1	Tyre	Pneumatique	Neumático
4	842537M1	1		1	Valve Stem	Valve de gonflage	Válvula de inflado

A Not serviced - order details
 Non fourni - commander détails
 No suministradas - pedir detalles

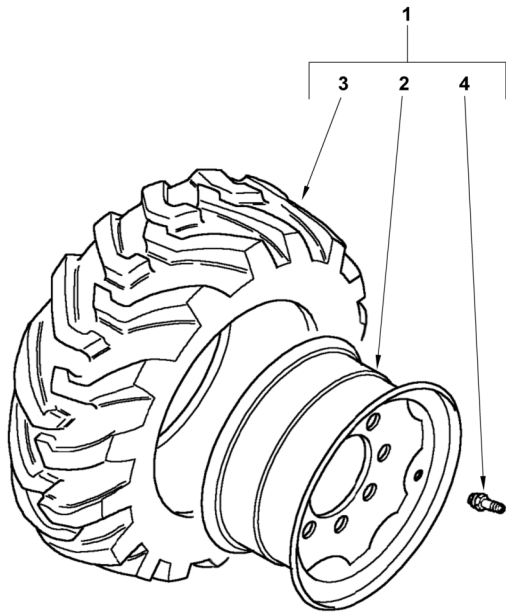

880
TX860B TX870B

841 842 843 844 845 851 852 853 854 855

Steering Wheel Spinner Knob Kit
Coffret de Poignée de Manœuvre Volant
Juego de asa de maniobra de volante

AC-98014-01.1-A

1	ACC01A			1	Accessory code	Code accessoire	Código accesorio
2	6106163M91	1		1	Knob	Boule	Bola

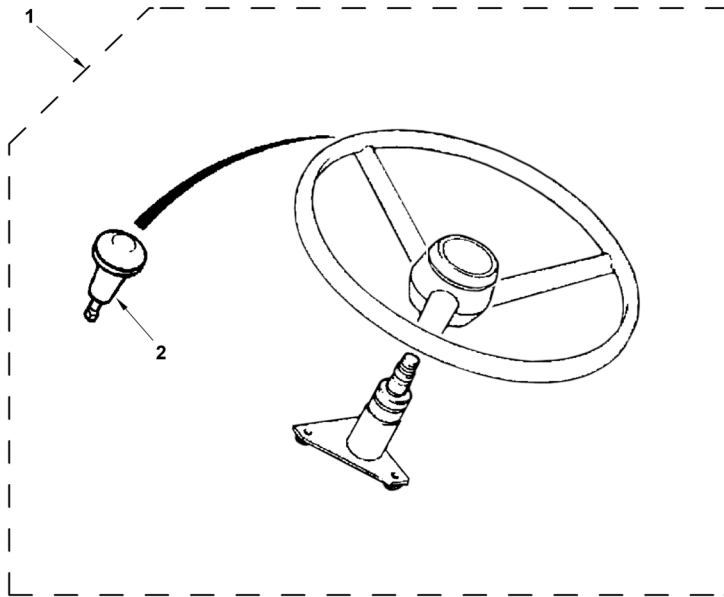

820 860 880 970 980
 TX760B TX860B
 TX870B TX970B

801 802 803 804 805 806 807 808 809 810 811 812 813 814 815 816 817 821 822
 823 824 825 831 832 833 834 841 842 843 844 845 851 852 853 854 855 921 922
 923 931 932

Steering Wheel Spinner Knob Kit
Coffret de Poignée de Manœuvre Volant
Juego de asa de maniobra de volante

C-98014-01.1-A

1	6106163M91		1	Knob	Boule	Bola
---	------------	--	---	------	-------	------

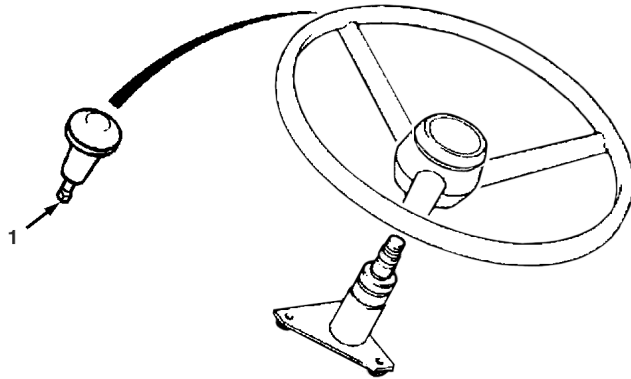

820 860 880 970 980
TX760B TX860B
TX870B TX970B

801 802 803 804 805 806 807 808 809 810 811 812 813 814 815 816 817 821 822
823 824 825 831 832 833 834 841 842 843 844 845 851 852 853 854 855 921 922
923 931 932

98014C01.1

6199042M3

1

Jan-06

Street Pads Kit
Coffret de Plaquettes Route
Juego de plataformas de calle

C-98110-01.1-A

1	6102860M92			2	Pad	Plaque antidérapante	Cinta antideslizante
2		1	➡ Ref.1	1	Pad	Plaque antidérapante	Cinta antideslizante
3	3516522M91	1		3	Pin, Linch	Goupille d'arrêt	Pasador de parada

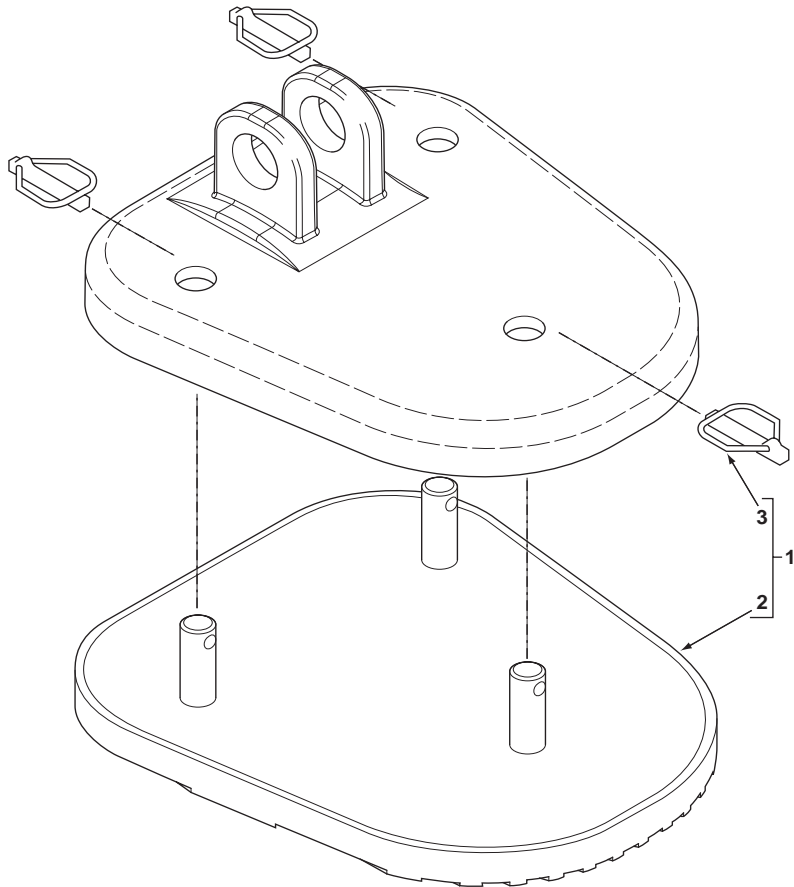

820 860 880 970 980
 TX760B TX860B

805 806 807 808 817 825 845 855 921 931

98110C01.1

6199042M3

1

Jan-06

Sunvisor Kit
Coffret de Visière
Juego de visera

C-98018-01.1-A

1	6099560M91		1	Shield, Sun	Pare-soleil	Parasol
2	3009666X1	M5 x 25	3	Screw	Vis	Tornillo

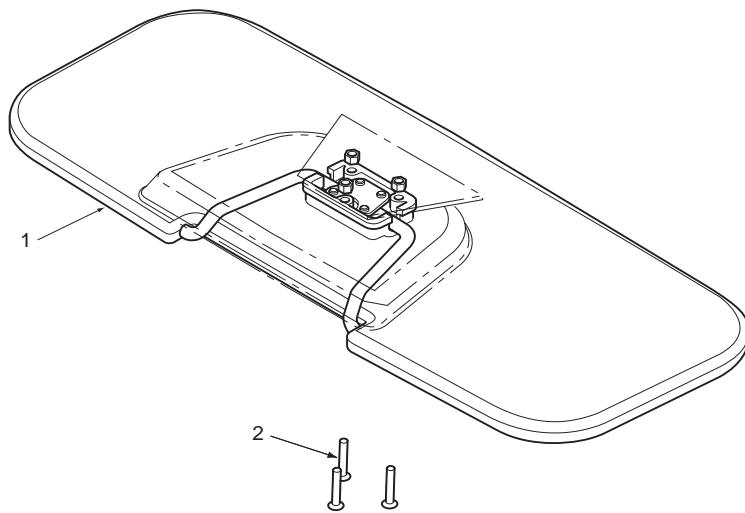

820 860 880 970 980
TX760B TX860B
TX870B TX970B

801 802 803 804 805 806 807 808 809 810 811 812 813 814 815 816 817 821 822
823 824 825 831 832 833 834 841 842 843 844 845 851 852 853 854 855 921 922
923 931 932

Tool Kit
Outillage - Clé à Roues
Herramienta

Wheel Brace + Grease Gun
Clé à Roues - Pompe à Graisse
Llave de ruedas + engrasador

C-89001-01.1-A

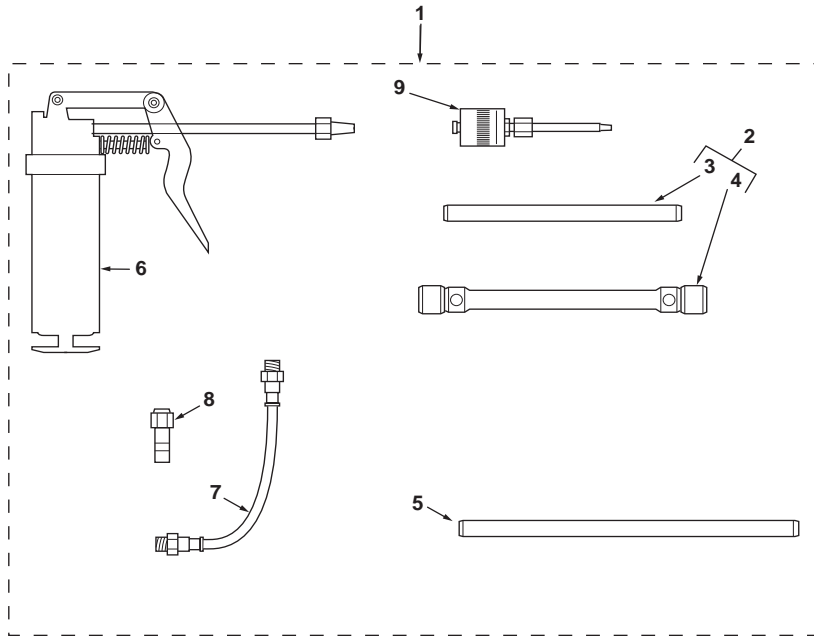

1	6106273M94			1	Kit, Tool	Kit d'outillage	Herramientas
2	6106272M92	1		1	Wrench	Clé	Llave
3		2	Ref.2	1	Bar	Barre	Barra
4		2	Ref.2	1	Wrench	Clé	Llave
5	6108796M1	1		1	Tube	Tubo	Tubo
6	3621101M1	1		1	Gun, Grease	Pompe à graisse	Bomba de grasa
7	3621108M1	1		1	Hose	Flexible	Tubo flexible
8	3621198M1	1		1	Coupling	Accouplement	Acoplamiento
9	6109585M1	1	Quick Grease	1	Adaptor	Adaptateur	Adaptador



820 860 880 970 980
 TX760B TX860B
 TX870B TX970B

801 802 803 804 805 806 807 808 809 810 811 812 813 814 815 816 817 821 822
 823 824 825 831 832 833 834 841 842 843 844 845 851 852 853 854 855 921 922
 923 931 932

89001C01.1

6199042M3

1

Jan-06

Tooth Guard Kit
Coffret de Protège-Dent
Juego de protección de dientes

With decal
Avec adhésif
Con adhesivo

Loader Bucket, 7-In-1
 Godet Chargeur 7-en-1
 Cuchara cargadora 7 x 1

Wide
 Wide
 Wide

C-95001-01.1-A

1	3519785M91		2386 mm	1	Guard Assy	Ensemble protection	Protector, Conj.
2	3522151M93	1	2386mm	1	Guard	Protecteur	Protector
3	1470338M1	1		2	Spring	Ressort	Muelle
4	6106687M1	1		2	Bracket	Patte de fixation	Pata de fijación
5	1471920M1	1		1	Decal	Adhésif	Adhesivo

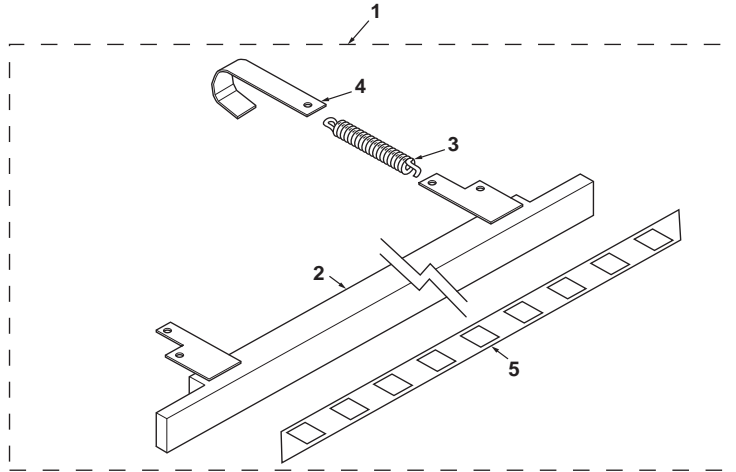

860 880 970
 TX860B TX870B

817 825 845 851 852 853 854 855 921

95001C01.1

6199042M3

1

Jan-06

Tooth Guard Kit
Coffret de Protège-Dent
Juego de protección de dientes

With decal
Avec adhésif
Con adhesivo

Loader Bucket, 7-In-1
 Godet Chargeur 7-en-1
 Cuchara cargadora 7 x 1

Narrow
 Narrow
 Narrow

C-95003-01.1-A

1	3519805M91		2286 mm	1	Guard Assy	Ensemble protection	Protector, Conj.
2	3516939M91	1	2286 mm	1	Guard	Protecteur	Protector
3	1470338M1	1		2	Spring	Ressort	Muelle
4	6106687M1	1		2	Bracket	Patte de fixation	Pata de fijación
5	1471920M1	1		1	Decal	Adhésif	Adhesivo

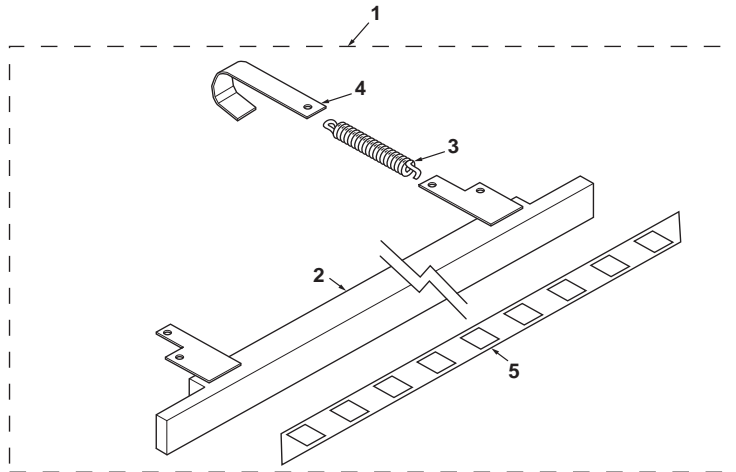

820 860 880
 TX760B TX860B

805 807 817 825 833 834 845 855

95003C01.1

6199042M3

1

Jan-06

Tooth Guard Kit
Coffret de Protège-Dent
Juego de protección de dientes

With decal
Avec adhésif
Con adhesivo

Standard Loader Bucket
 Godet Chargeur Standard
 Cuchara cargadora estándar

Narrow
 Narrow
 Narrow

C-95005-01.1-A

1	3516937M91			1	Guard Assy	Ensemble protection	Protector, Conj.
2	3516939M91	1	2286 mm	1	Guard	Protecteur	Protector
3	1470338M1	1		2	Spring	Ressort	Muelle
4	3516782M2	1		2	Hook	Crochet	Gancho
5	1471920M1	1		1	Decal	Adhésif	Adhesivo

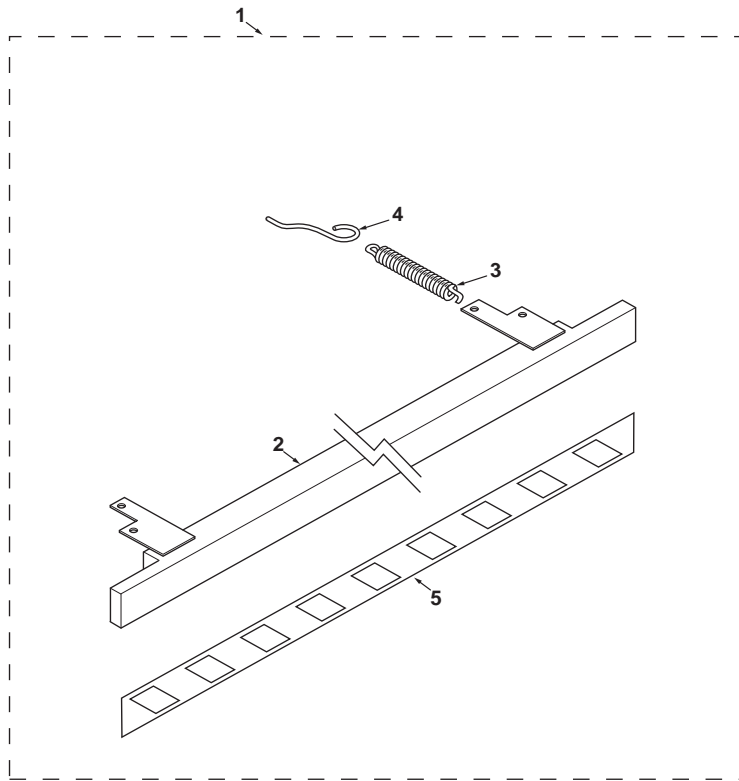

820 860 880
 TX760B TX860B

805 807 817 825 833 834 845 855

95005C01.1

6199042M3

1

Jan-06

Tooth Guard Kit
Coffret de Protège-Dent
Juego de protección de dientes

With decal
Avec adhésif
Con adhesivo

Standard Loader Bucket
 Godet Chargeur Standard
 Cuchara cargadora estándar

Wide
 Wide
 Wide

C-95007-01.1-A

1	3522150M94			1	Guard Assy	Ensemble protection	Protector, Conj.
2	3522151M93	1	2386mm	1	Guard	Protecteur	Protector
3	1470338M1	1		2	Spring	Ressort	Muelle
4	3516782M2	1		2	Hook	Crochet	Gancho
5	1471920M1	1		1	Decal	Adhésif	Adhesivo

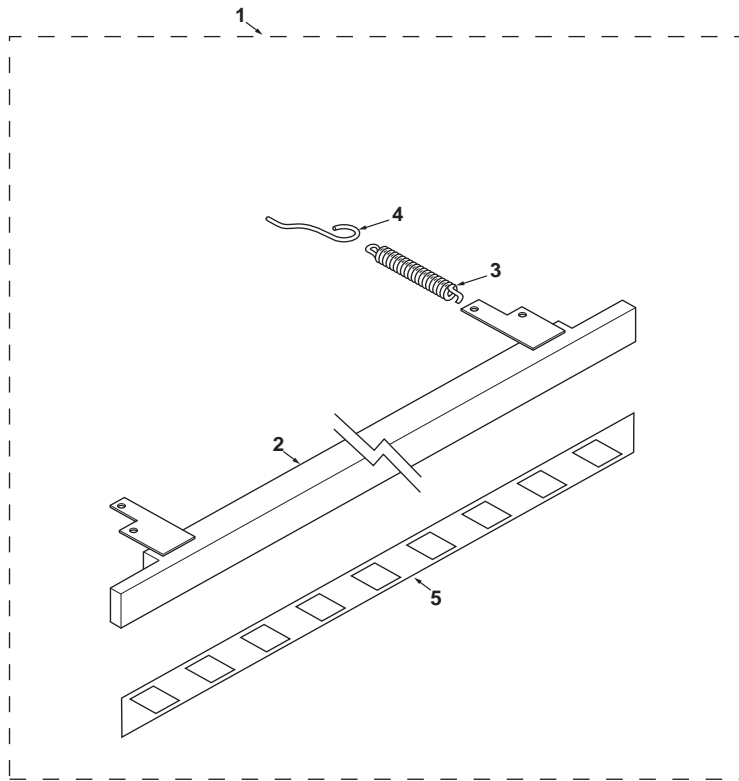

820 860 880
 TX760B TX860B

805 807 817 825 833 834 845 855

95007C01.1

6199042M3

1

Jan-06

Tooth Guard Kit
Coffret de Protège-Dent
Juego de protección de dientes

Without Decal
Sans adhésif
Sin adhesivo

Loader Bucket, 7-In-1
 Godet Chargeur 7-en-1
 Cuchara cargadora 7 x 1

Wide
 Wide
 Wide

C-95002-01.1-A

1	3519786M91		2386 mm	1	Guard Assy	Ensemble protection	Protector, Conj.
2	3522151M93	1	2386mm	1	Guard	Protecteur	Protector
3	1470338M1	1		2	Spring	Ressort	Muelle
4	6106687M1	1		2	Bracket	Patte de fixation	Pata de fijación

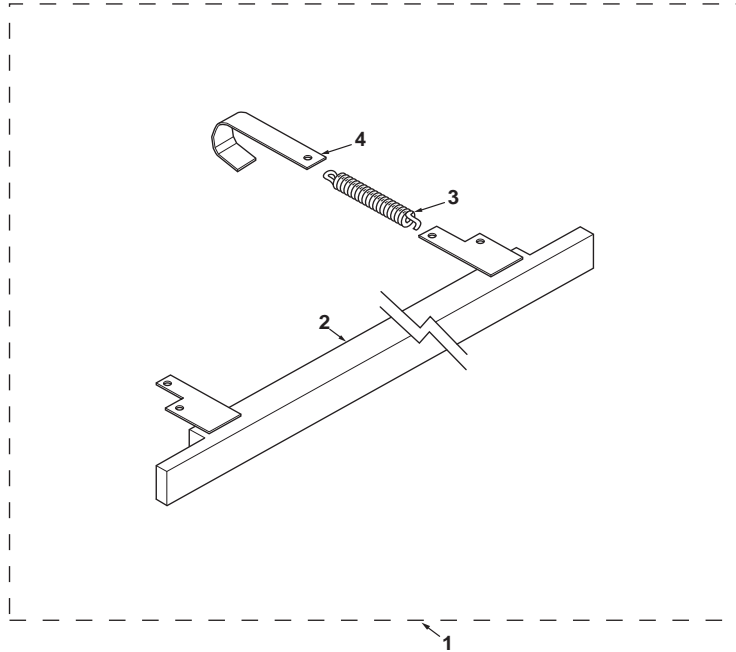

860 880 970 980
 TX860B TX870B
 TX970B

813 814 815 816 817 821 822 823 824 825 841 842 843 844 845 851 852 853 854
 855 921 922 923 931 932

95002C01.1

6199042M3

1

Jan-06

Tooth Guard Kit
Coffret de Protège-Dent
Juego de protección de dientes

Without Decal
Sans adhésif
Sin adhesivo

Loader Bucket, 7-In-1
 Godet Chargeur 7-en-1
 Cuchara cargadora 7 x 1

Narrow
 Narrow
 Narrow

C-95004-01.1-A

1	3519806M91		2286 mm	1	Guard Assy	Ensemble protection	Protector, Conj.
2	3516939M91	1	2286 mm	1	Guard	Protecteur	Protector
3	1470338M1	1		2	Spring	Ressort	Muelle
4	6106687M1	1		2	Bracket	Patte de fixation	Pata de fijación

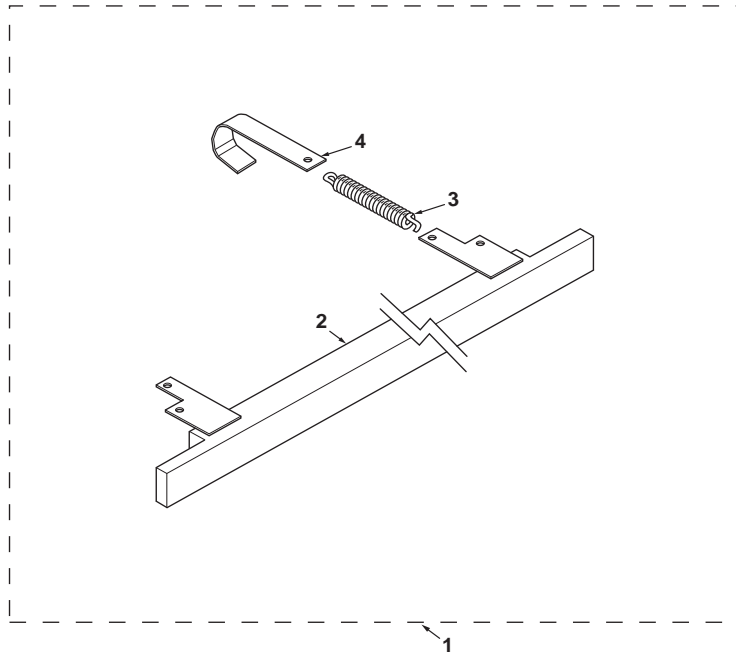

820 860 880
 TX760B TX860B
 TX870B

801 802 803 804 805 806 807 808 813 814 815 816 817 821 822 823 824 825 831
 832 833 834 841 842 843 844 845 851 852 853 854 855

95004C01.1

6199042M3

1

Jan-06

Tooth Guard Kit
Coffret de Protège-Dent
Juego de protección de dientes

Without Decal
Sans adhésif
Sin adhesivo

Standard Loader Bucket
 Godet Chargeur Standard
 Cuchara cargadora estándar

Narrow
 Narrow
 Narrow

C-95006-01.1-A

1	3516936M91		2286mm	1	Guard Assy	Ensemble protection	Protector, Conj.
2	3516939M91	1	2286 mm	1	Guard	Protecteur	Protector
3	1470338M1	1		2	Spring	Ressort	Muelle
4	3516782M2	1		2	Hook	Crochet	Gancho

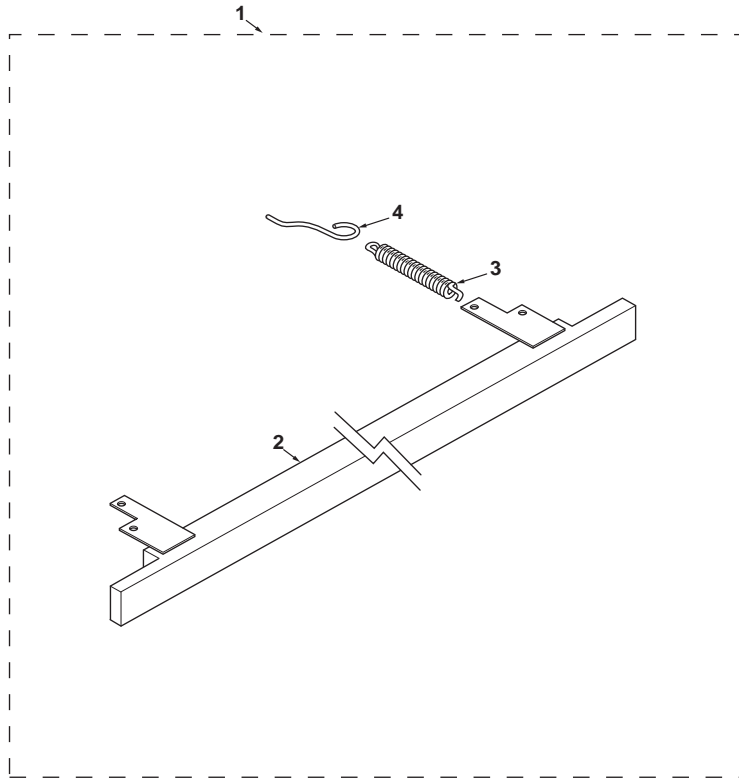

820 860 880
 TX760B TX860B
 TX870B

801 802 803 804 805 806 807 808 813 814 815 816 817 821 822 823 824 825 831
 832 833 834 841 842 843 844 845 851 852 853 854 855

95006C01.1

6199042M3

1

Jan-06

Tooth Guard Kit
Coffret de Protège-Dent
Juego de protección de dientes

Without Decal
Sans adhésif
Sin adhesivo

Standard Loader Bucket
 Godet Chargeur Standard
 Cuchara cargadora estándar

Wide
 Wide
 Wide

C-95008-01.1-A

1	3522149M94		2386mm	1	Guard Assy	Ensemble protection	Protector, Conj.
2	3522151M93	1	2386mm	1	Guard	Protecteur	Protector
3	1470338M1	1		2	Spring	Ressort	Muelle
4	3516782M2	1		2	Hook	Crochet	Gancho

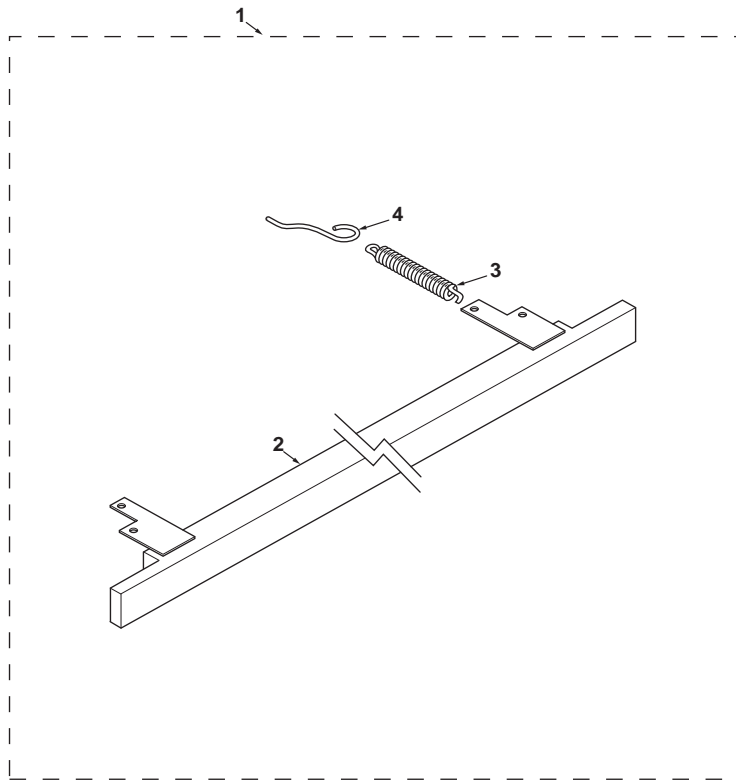

820 860 880 970 980
 TX760B TX860B
 TX870B TX970B

801 802 803 804 805 806 807 808 813 814 815 816 817 821 822 823 824 825 831
 832 833 834 841 842 843 844 845 851 852 853 854 855 921 922 923 931 932

95008C01.1

6199042M3

1

Jan-06

Transport Height Decal Kit
Coffret de Adhésif Hauteur
Juego de altura adhesivo

C-95009-01.1-A

1	6101996M1		1	Decal	Adhésif	Adhesivo
---	-----------	--	---	-------	---------	----------

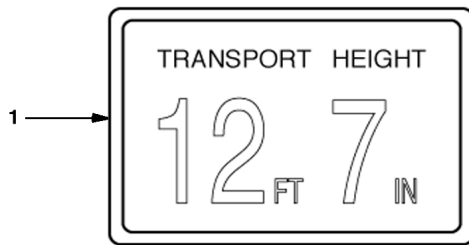

820 860 880 970 980
TX760B TX860B
TX870B TX970B

801 802 803 804 805 806 807 808 813 814 815 816 817 821 822 823 824 825 831
832 833 834 841 842 843 844 845 851 852 853 854 855 921 922 923 931 932

95009C01.1

6199042M3

1

Jan-06

Worklight Kit
Coffret de Feu de Travail
Juego de faro de trabajo

C-98105-01.1-A

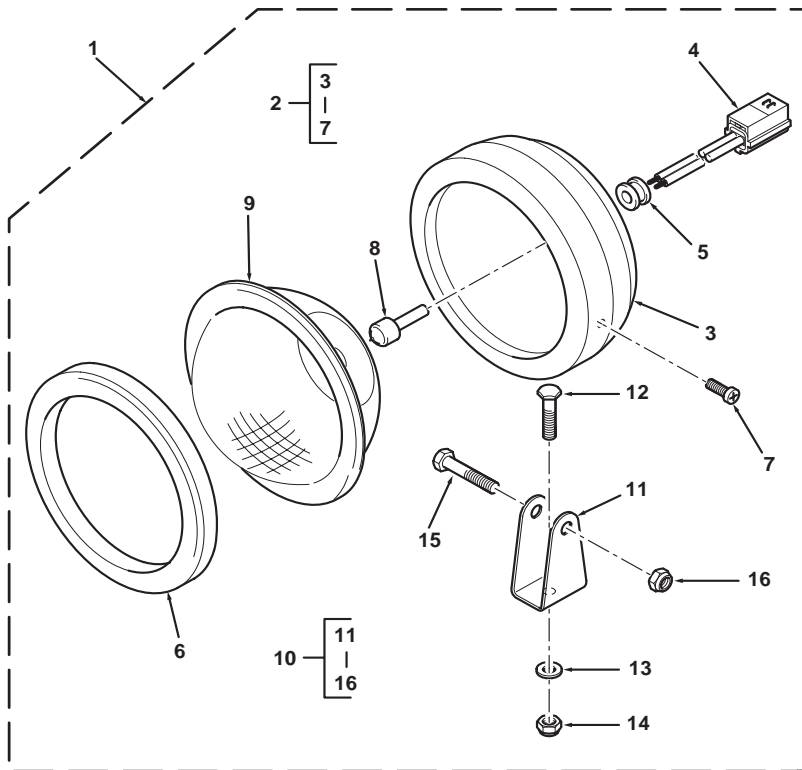

1	6110033M91			2	Lamp Assy, Work	Ensemble phare travail	Faro de trabajo, Conj.
2	6194001M91	1		1	Kit, Parts	Lot de pièces	Juego de piezas
3		2	Ref. 2	1	Body	Corps	Cuerpo
4		2	Ref. 2	1	Harness	Faisceau	Haz
5		2	Ref. 2	1	Grommet	Passe-fil	Pasa cable
6		2	Ref. 2	1	Rim	Jante	Corona
7		2	Ref. 2	1	Screw	Vis	Tornillo
8	3523689M1	1	12V - 55W	1	Bulb	Lampe	Lámpara
9	6194002M91	1		1	Reflector	Catadioptré	Reflector
10	6194003M91	1		1	Kit, Parts	Lot de pièces	Juego de piezas
11		10	Ref. 10	1	Bracket	Patte de fixation	Pata de fijación
12		10	Ref. 10	1	Bolt	Boulon	Perno
13		10	Ref. 10	1	Washer	Rondelle	Arandela
14		10	Ref. 10	1	Nut	Écrou	Tuerca
15		10	Ref. 10	1	Bolt	Boulon	Perno
16		10	Ref. 10	1	Nut	Écrou	Tuerca



820 860 880 970 980
 TX760B TX860B
 TX870B TX970B

801 803 805 807 809 811 813 815 817 821 823 825 831 833 841 843 845 851 853
 855 921 922 923 931 932

98105C01.1

6199042M3

1

Jan-06

Worklight Kit
Coffret de Feu de Travail
Juego de faro de trabajo

C-98185-01.1-A

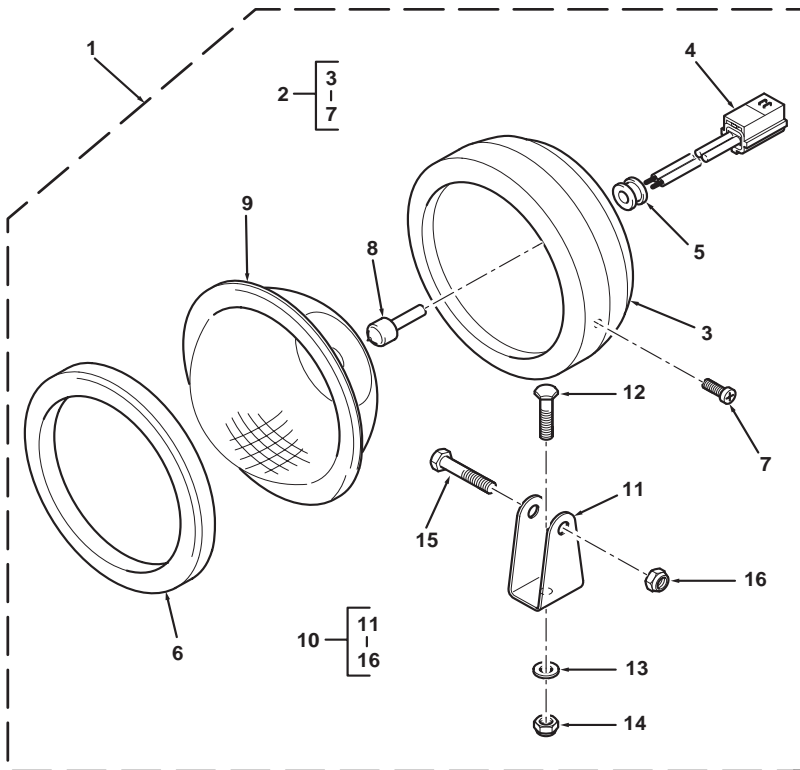

1	6110678M91			2	Lamp Assy, Work	Ensemble phare travail	Faro de trabajo, Conj.
2	6194299M91	1		1	Kit, Parts	Lot de pièces	Juego de piezas
3		2	▶ Ref. 2	1	Body	Corps	Cuerpo
4		2	▶ Ref. 2	1	Harness	Faisceau	Haz
5		2	▶ Ref. 2	1	Grommet	Passe-fil	Pasa cable
6		2	▶ Ref. 2	1	Rim	Jante	Corona
7		2	▶ Ref. 2	1	Screw	Vis	Tornillo
8	3523689M1	1	12V - 55W	1	Bulb	Lampe	Lámpara
9	6194002M91	1		1	Reflector	Catadioptre	Reflector
10	6194003M91	1		1	Kit, Parts	Lot de pièces	Juego de piezas
11		10	▶ Ref. 10	1	Bracket	Patte de fixation	Pata de fijación
12		10	▶ Ref. 10	1	Bolt	Boulon	Perno
13		10	▶ Ref. 10	1	Washer	Rondelle	Arandela
14		10	▶ Ref. 10	1	Nut	Écrou	Tuerca
15		10	▶ Ref. 10	1	Bolt	Boulon	Perno
16		10	▶ Ref. 10	1	Nut	Écrou	Tuerca



880
 TX760B TX860B
 TX870B

832 834 842 844 852

98185C01.1

6199042M3

1

Jan-06

B - Loader Buckets • Bennes de chargeur • Cucharas de la cargadora

Loader Bucket	66007C01.1	Godet Chargeur	Cuchara cargadora
Loader Bucket - 7 In 1	66005AC01.1	Godet Chargeur - 7 x 1	Cuchara cargadora - 7 x 1
Loader Bucket - 7 In 1	66005AC02.1	Godet Chargeur - 7 x 1	Cuchara cargadora - 7 x 1
Loader Bucket - 7 In 1	66005AC03.1	Godet Chargeur - 7 x 1	Cuchara cargadora - 7 x 1
Loader Bucket - 7 In 1	66005C01.1	Godet Chargeur - 7 x 1	Cuchara cargadora - 7 x 1
Loader Bucket - 7 In 1	66005C02.1	Godet Chargeur - 7 x 1	Cuchara cargadora - 7 x 1
Loader Bucket - 7 In 1	66005C03.1	Godet Chargeur - 7 x 1	Cuchara cargadora - 7 x 1
Loader Bucket - 7 In 1	66006AC01.1	Godet Chargeur - 7 x 1	Cuchara cargadora - 7 x 1
Loader Bucket - 7 In 1	66006AC02.1	Godet Chargeur - 7 x 1	Cuchara cargadora - 7 x 1
Loader Bucket - 7 In 1	66006AC03.1	Godet Chargeur - 7 x 1	Cuchara cargadora - 7 x 1
Loader Bucket - 7 In 1	66006C01.1	Godet Chargeur - 7 x 1	Cuchara cargadora - 7 x 1
Loader Bucket - 7 In 1	66006C02.1	Godet Chargeur - 7 x 1	Cuchara cargadora - 7 x 1
Loader Bucket - 7 In 1	66006C03.1	Godet Chargeur - 7 x 1	Cuchara cargadora - 7 x 1
Loader Bucket - Standard.....	66003AC01.1	Godet Chargeur - Standard	Cuchara cargadora - Estándar
Loader Bucket - Standard.....	66003C01.1	Godet Chargeur - Standard	Cuchara cargadora - Estándar
Loader Bucket - Standard.....	66004AC01.1	Godet Chargeur - Standard	Cuchara cargadora - Estándar
Loader Bucket - Standard.....	66004C01.1	Godet Chargeur - Standard	Cuchara cargadora - Estándar



Loader Bucket
 Godet Chargeur
 Cuchara cargadora

Less Bucket
 Sans godet
 Sin cuchara

C-66007-01.1-A

1	3518087M91			1	Bar	Barre	Barra
2	3518086M1	1		1	Bar	Barre	Barra
3	3516522M91	1		1	Pin, Linch	Goupille d'arrêt	Pasador de parada
4	3019327X1	1	M12 x 60	1	Pin	Axe	Pasador

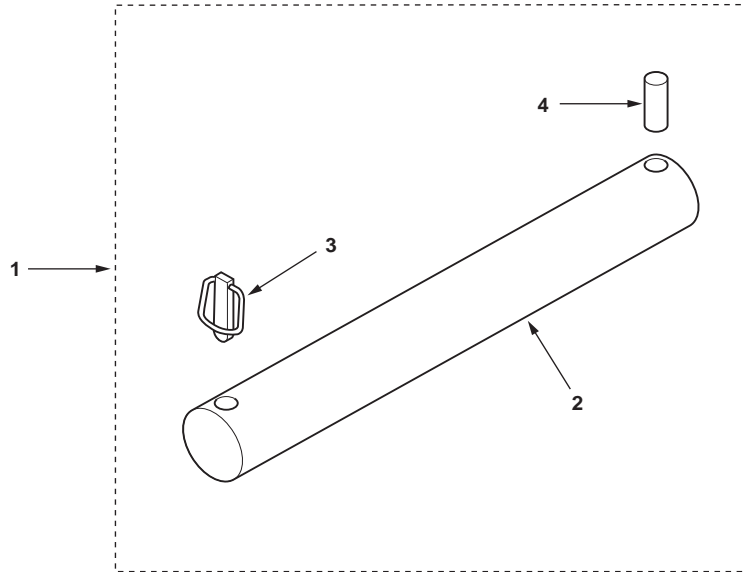

820 860 880 970 980
 TX760B TX860B
 TX870B TX970B

801 802 803 804 805 806 807 808 809 810 811 812 813 814 815 816 817 821 822
 823 824 825 831 832 833 834 841 842 843 845 851 852 853 854 855 921 922 923
 931 932

**Loader Bucket
Godet Chargeur
Cuchara cargadora**

**7 In 1
7 x 1
7 x 1**

AC-66005-01.1-A

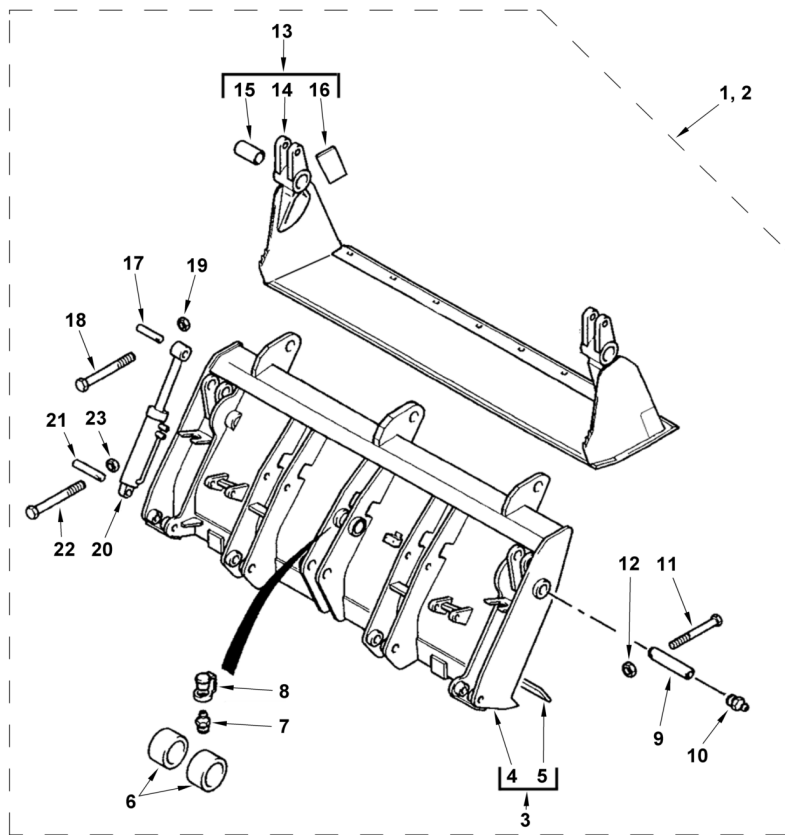

1	ACC42A		Bucket & Blade	1	Accessory code	Code accessoire	Código accesorio
2	6106218M92	1	1.0m³	1	Bucket 7 In 1	Godet 7 en 1	Cuchara - 7 X 1
3	6103622M92	2		1	Bucket 7 In 1	Godet 7 en 1	Cuchara - 7 X 1
4		3		1	Bucket	Godet	Cuchara
5	6103678M1	3	▶ Ref. 3 2310 mm	1	Blade, Dozer	Lame	Cuchilla
6	3520033M1	2		2	Bushing	Bague	Anillo
7	339608X1	2		1	Fitting, Grease	Graisneur	Engrasador
8	3516180M2	2		1	Cover	Cache	Tapa
9	3507539M1	2	45 x 203 mm	2	Pin	Axe	Pasador
10	365572X1	2		2	Fitting, Grease	Graisneur	Engrasador
11	3009504X1	2	M10 x 100	2	Screw	Vis	Tornillo
12	1440329X1	2	M10	2	Nut, Lock	Écrou de blocage	Tuerca de retención
13	6103648M92	2		1	Clam Assy	Ensemble de mâchoire	Mordaza, Conj.
14		13	▶ Ref. 13	1	Clam Assy	Ensemble de mâchoire	Mordaza, Conj.
15	3519689M1	13		2	Bushing	Bague	Anillo
16	6103657M1	13		2	Edge, Cutting	Lame d'attaque	Cuchilla de ataque
17	6106215M1	2	30 x 115 mm	2	Pin	Axe	Pasador
18	339891X1	2	M8 x 80	2	Screw	Vis	Tornillo
19	394367X1	2	M8	2	Nut, Lock	Écrou de blocage	Tuerca de retención
20		2	66005C03.1 1	2	Cylinder	Cylindre	Cilindro
21	3517159M1	2	30 x 145 mm	2	Pin	Axe	Pasador
22	390246X1	2	M8 x 70	2	Bolt	Boulon	Perno
23	394367X1	2	M8	2	Nut, Lock	Écrou de blocage	Tuerca de retención



820 860 880
TX760B TX860B
TX870B

801 802 803 804 805 806 807 808 809 810 811 812 813 814 815 816 817 821 822
823 824 825 831 832 833 834 841 842 843 845 851 852 853 854 855

66005AC01.1

6199042M3

1

Jan-06

Loader Bucket
 Godet Chargeur
 Cuchara cargadora

7 In 1
 7 x 1
 7 x 1

Bucket Pipework
 Tuyauteries Godet
 Tubazione di lavoro per benna

AC-66005-02.1-A

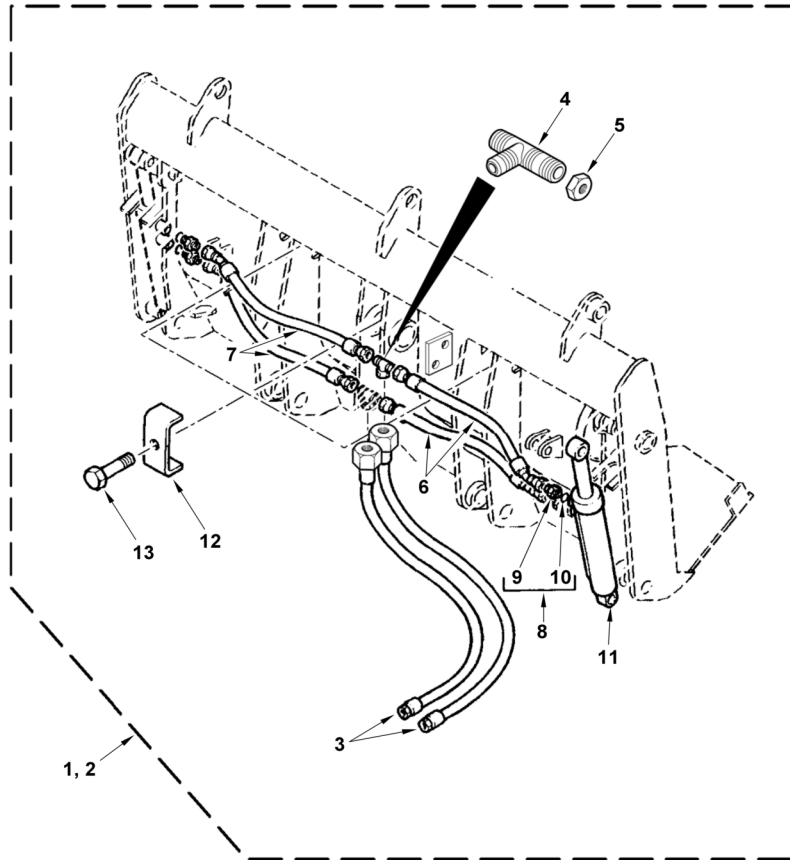

1	ACC42A		Continued Bucket & Blade	1	Accessory code	Code accessoire	Código accesorio
2	6106218M92	1	Continued 1.0m ³	1	Bucket 7 In 1	Godet 7 en 1	Cuchara - 7 X 1
3	6106214M91	2		2	Hose Assy	Ensemble de flexible	Flexible, Conj.
4	218-1236	2		2	Tee	Raccord en T	Te
5	356614X1	2		2	Nut, Lock	Écrou de blocage	Tuerca de retención
6	6106212M91	2		2	Hose Assy	Ensemble de flexible	Flexible, Conj.
7	6106213M91	2		2	Hose Assy	Ensemble de flexible	Flexible, Conj.
8	835091M91	2	9/16	4	Union	Union	Unión
9		8	➔ Ref. 8	1	Union	Union	Unión
10	831452M1	8		1	O-Ring	Joint torique	Junta de tipo O
11		2	👁 66005C03.1 1	2	Cylinder	Cylindre	Cilindro
12	3522094M2	2		3	Bracket, Clamp	Bride de fixation	Brida de fijación
13	339761X1	2	M8 x 25	3	Screw	Vis	Tornillo



820 860 880
 TX760B TX860B
 TX870B

801 802 803 804 805 806 807 808 809 810 811 812 813 814 815 816 817 821 822
 823 824 825 831 832 833 834 841 842 843 845 851 852 853 854 855

66005AC02.1

6199042M3

1

Jan-06

Loader Bucket
Godet Chargeur
Cuchara cargadora

7 In 1
7 x 1
7 x 1

Cylinder
Cylindre
Cilindro

AC-66005-03.1-A

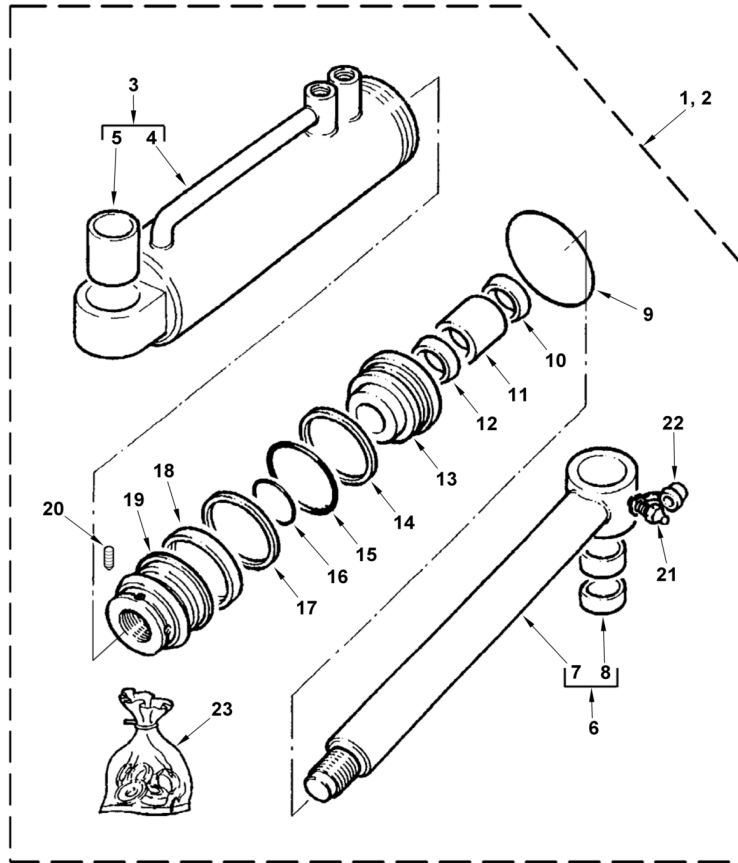

1	ACC42A		Bucket & Blade	1	Accessory code	Code accessoire	Código accesorio
2	6106632M91	1	● [66005C01.1 20] ● [66005C02.1 11]	2	Cylinder Assy	Ensemble de vérin	Gato, Conj.
3	5002708M91	2		1	Tube, Cylinder	Cylindre de vérin	Cilindro de gato
4		3	➤ Ref. 3	1	Tube, Cylinder	Cylindre de vérin	Cilindro de gato
5	5002510M1	3		1	Bushing	Bague	Anillo
6	5002711M91	2		1	Rod, Piston	Tige de vérin	Vástago cilindro
7		6	➤ Ref. 5	1	Rod, Piston	Tige de vérin	Vástago cilindro
8	5002717M1	6		2	Bushing	Bague	Anillo
9	3487205M1	2 (A)		1	O-Ring	Joint torique	Junta de tipo O
10	1605446M1	2 (A)		1	Wiper	Racleur	Raspador, Escobilla
11	3485978M1	2		1	Bearing, Gland	Coussinet de palier	Cojinete de palier
12	3485976M1	2 (A)		1	Seal	Joint	Junta
13	3624984M1	2		1	Gland, Cylinder	Palier de vérin	Palier de gato
14	1884170M1	2 (A)		1	Ring, Backup	Contre-joint	ContraJunta
15	359187X1	2 (A)		1	O-Ring	Joint torique	Junta de tipo O
16	3312583M1	2 (A)		1	O-Ring	Joint torique	Junta de tipo O
17	3485241M1	2 (A)		1	Ring	Anneau	Aro
18	3487067M1	2 (A)		1	Ring, Sealing	Bague d'étanchéité	Anillo, Estanqueidad
19	3624983M1	2		1	Piston	Piston	Pistón
20	3402928M1	2 (A)		1	Screw	Vis	Tornillo
21	365572X1	2		1	Fitting, Grease	Graisser	Engrasador
22	3516180M2	2		1	Cover	Cache	Tapa
23	6193231M91		(B)	1	Kit, Seal	Pochette de joints	Juego de juntas

A Included in kit marked (B)
Inclus dans jeu marqué (B)
Incluido en juego marcado (B)

B Contains items marked (A)
Comprend les pièces marquées (A)
Incluye las piezas marcadas (A)



820 860 880
TX760B TX860B
TX870B

801 802 803 804 805 806 807 808 809 810 811 812 813 814 815 816 817 821 822
823 824 825 831 832 833 834 841 842 843 845 851 852 853 854 855

66005AC03.1

6199042M3

1

Jan-06

**Loader Bucket
Godet Chargeur
Cuchara cargadora**

**7 In 1
7 x 1
7 x 1**

C-66005-01.1-A

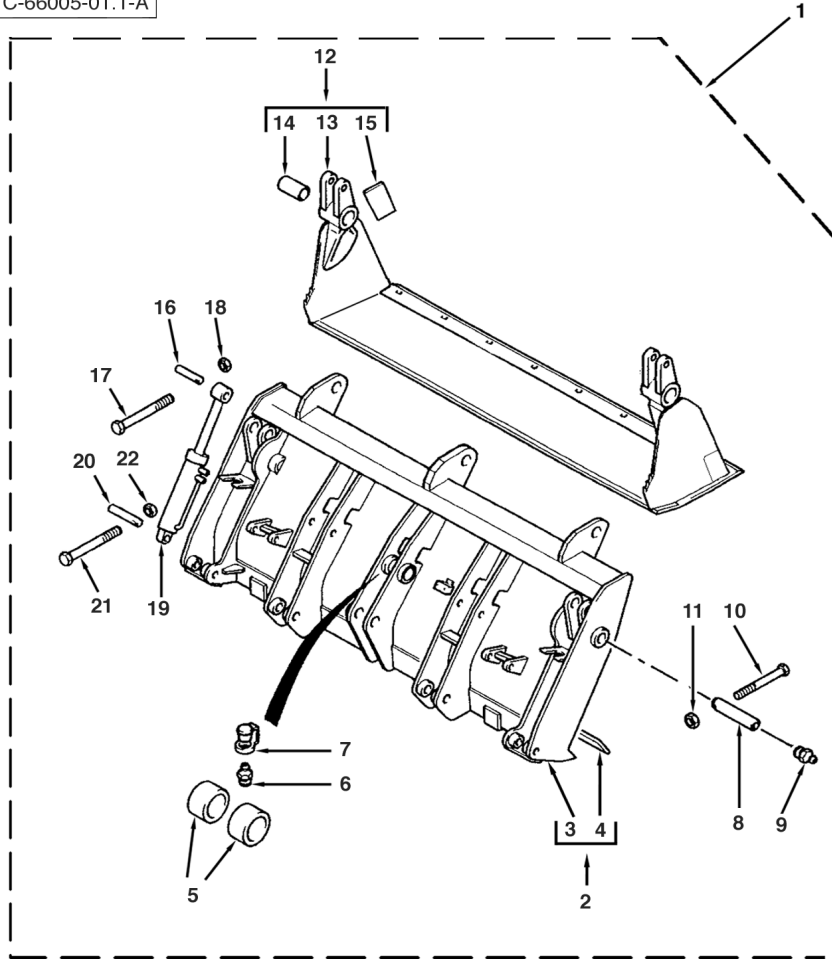

1	6106218M92		1.0m³	1	Bucket 7 In 1	Godet 7 en 1	Cuchara - 7 X 1
2	6103622M92	1		1	Bucket 7 In 1	Godet 7 en 1	Cuchara - 7 X 1
3		2		1	Bucket	Godet	Cuchara
4	6103678M1	2	➡ Ref.2 2310 mm	1	Blade, Dozer	Lame	Cuchilla
5	3520033M1	1		2	Bushing	Bague	Anillo
6	339608X1	1		1	Fitting, Grease	Graisser	Engrasador
7	3516180M2	1		1	Cover	Cache	Tapa
8	3507539M1	1	45 x 203 mm	2	Pin	Axe	Pasador
9	365572X1	1		2	Fitting, Grease	Graisser	Engrasador
10	3009504X1	1	M10 x 100	2	Screw	Vis	Tornillo
11	1440329X1	1	M10	2	Nut, Lock	Écrou de blocage	Tuerca de retención
12	6103648M92	1		1	Clam Assy	Ensemble de mâchoire	Mordaza, Conj.
13		12	➡ Ref.12	1	Clam Assy	Ensemble de mâchoire	Mordaza, Conj.
14	3519689M1	12		2	Bushing	Bague	Anillo
15	6103657M1	12		2	Edge, Cutting	Lame d'attaque	Cuchilla de ataque
16	6106215M1	1	30 x 115 mm	2	Pin	Axe	Pasador
17	339891X1	1	M8 x 80	2	Screw	Vis	Tornillo
18	394367X1	1	M8	2	Nut, Lock	Écrou de blocage	Tuerca de retención
19		1	66005C03.1 1	2	Cylinder	Cylindre	Cilindro
20	3517159M1	1	30 x 145 mm	2	Pin	Axe	Pasador
21	390246X1	1	M8 x 70	2	Bolt	Boulon	Perno
22	394367X1	1	M8	2	Nut, Lock	Écrou de blocage	Tuerca de retención



801 802 803 804 805 806 807 808 809 810 811 812 813 814 815 816 817 821 822
823 824 825 831 832 833 834 841 842 843 845 851 852 853 854 855

66005C01.1

6199042M3

1

Jan-06

Loader Bucket
Godet Chargeur
Cuchara cargadora

7 In 1
7 x 1
7 x 1
 Bucket Pipework
 Tuyauteries Godet
 Tubazione di lavoro per benna

C-66005-02.1-A

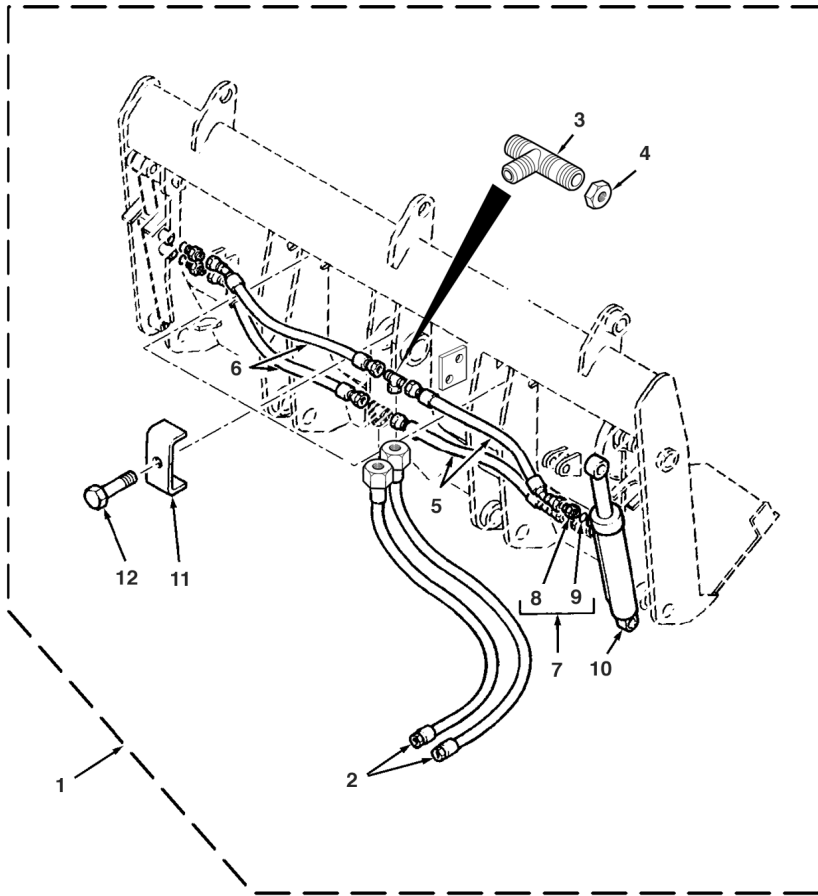

1	6106218M92		Continued 1.0m ³	1	Bucket 7 In 1	Godet 7 en 1	Cuchara - 7 X 1
2	6106214M91	1		2	Hose Assy	Ensemble de flexible	Flexible, Conj.
3	218-1236	1		2	Tee	Raccord en T	Te
4	356614X1	1		2	Nut, Lock	Écrou de blocage	Tuerca de retención
5	6106212M91	1		2	Hose Assy	Ensemble de flexible	Flexible, Conj.
6	6106213M91	1		2	Hose Assy	Ensemble de flexible	Flexible, Conj.
7	835091M91	1	9/16	4	Union	Union	Unión
8		7	Ref.7	1	Union	Union	Unión
9	831452M1	7		1	O-Ring	Joint torique	Junta de tipo O
10		1	66005C03.1 1	2	Cylinder	Cylindre	Cilindro
11	3522094M2	1		3	Bracket, Clamp	Bride de fixation	Brida de fijación
12	339761X1	1	M8 x 25	3	Screw	Vis	Tornillo



801 802 803 804 805 806 807 808 809 810 811 812 813 814 815 816 817 821 822
 823 824 825 831 832 833 834 841 842 843 845 851 852 853 854 855

66005C02.1

6199042M3

1

Jan-06

Loader Bucket
Godet Chargeur
Cuchara cargadora

7 In 1
7 x 1
7 x 1

Cylinder
Cylindre
Cilindro

C-66005-03.1-A

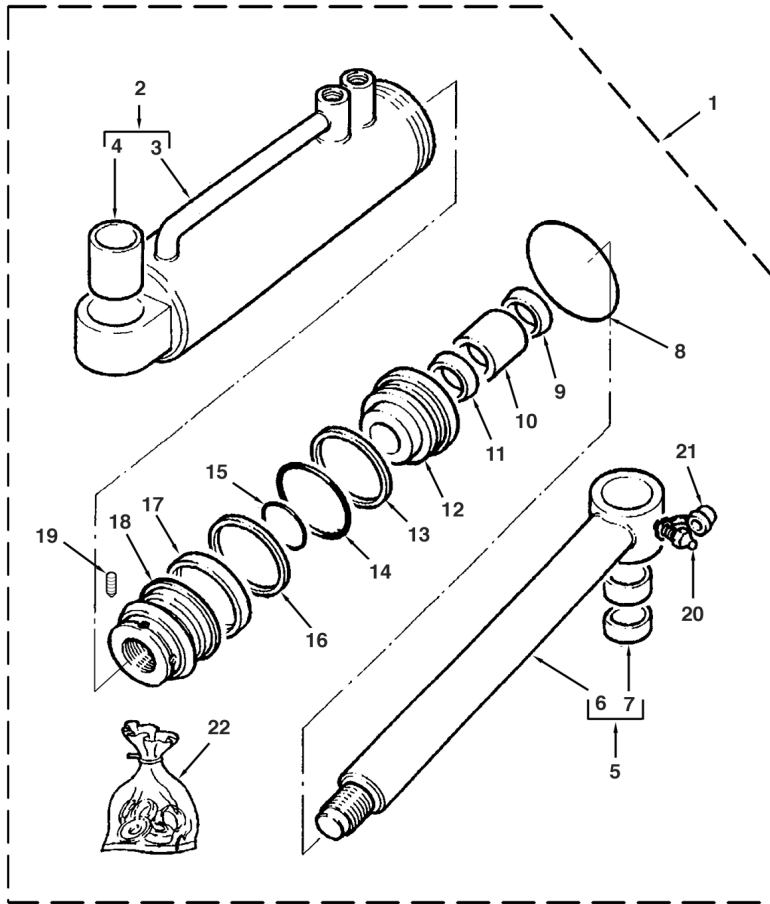

1	6106632M91	66005C01.1 19 66005C02.1 10	2	Cylinder Assy	Ensemble de vérin	Gato, Conj.
2	5002708M91	1	1	Tube, Cylinder	Cylindre de vérin	Cilindro de gato
3		2	1	Tube, Cylinder	Cylindre de vérin	Cilindro de gato
4	5002510M1	2	1	Bushing	Bague	Anillo
5	5002711M91	1	1	Rod, Piston	Tige de vérin	Vástago cilindro
6		5	1	Rod, Piston	Tige de vérin	Vástago cilindro
7	5002717M1	5	2	Bushing	Bague	Anillo
8	3487205M1	1 (A)	1	O-Ring	Joint torique	Junta de tipo O
9	1605446M1	1 (A)	1	Wiper	Racleur	Raspador, Escobilla
10	3485978M1	1	1	Bearing, Gland	Coussinet de palier	Cojinete de palier
11	3485976M1	1 (A)	1	Seal	Joint	Junta
12	3624984M1	1	1	Gland, Cylinder	Palier de vérin	Palier de gato
13	1884170M1	1 (A)	1	Ring, Backup	Contre-joint	Contrajunta
14	359187X1	1 (A)	1	O-Ring	Joint torique	Junta de tipo O
15	3312583M1	1 (A)	1	O-Ring	Joint torique	Junta de tipo O
16	3485241M1	1 (A)	1	Ring	Anneau	Aro
17	3487067M1	1 (A)	1	Ring, Sealing	Bague d'étanchéité	Anillo, Estanqueidad
18	3624983M1	1	1	Piston	Piston	Pistón
19	3402928M1	1 (A)	1	Screw	Vis	Tornillo
20	365572X1	1	1	Fitting, Grease	Graisser	Engrasador
21	3516180M2	1	1	Cover	Cache	Tapa
22	6193231M91	(B)	1	Kit, Seal	Pochette de joints	Juego de juntas

A Included in kit marked (B)
Inclus dans jeu marqué (B)
Incluido en juego marcado (B)

B Contains items marked (A)
Comprend les pièces marquées (A)
Incluye las piezas marcadas (A)



820 860 880
TX760B TX860B
TX870B

801 802 803 804 805 806 807 808 809 810 811 812 813 814 815 816 817 821 822
823 824 825 831 832 833 834 841 842 843 845 851 852 853 854 855

66005C03.1

6199042M3

1

Jan-06

**Loader Bucket
Godet Chargeur
Cuchara cargadora**

**7 In 1
7 x 1
7 x 1**

AC-66006-01.1-A

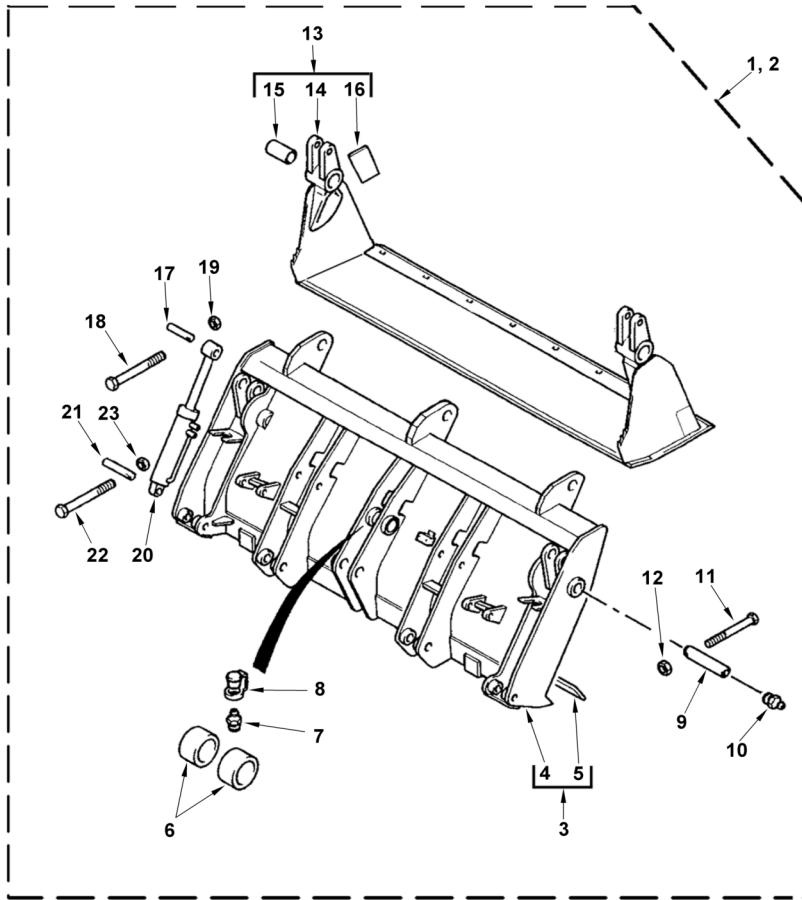

1	ACC42B		Bucket & Blade	1	Accessory code	Code accessoire	Código accesorio
2	6106283M92	1	1.2m ³	1	Bucket 7 In 1	Godet 7 en 1	Cuchara - 7 X 1
3	6103620M92	2		1	Bucket 7 In 1	Godet 7 en 1	Cuchara - 7 X 1
4		3	 Ref. 3	1	Bucket	Godet	Cuchara
5	3519514M1	3	2386 mm	1	Blade, Dozer	Lame	Cuchilla
6	3520033M1	2		2	Bushing	Bague	Anillo
7	339608X1	2		1	Fitting, Grease	Graisneur	Engrasador
8	3516180M2	2		1	Cover	Cache	Tapa
9	3507539M1	2	45 x 203 mm	2	Pin	Axe	Pasador
10	365572X1	2		2	Fitting, Grease	Graisneur	Engrasador
11	3009504X1	2	M10 x 100	2	Screw	Vis	Tornillo
12	1440329X1	2	M10	2	Nut, Lock	Écrou de blocage	Tuerca de retención
13	6103647M92	2		1	Clam Assy	Ensemble de mâchoire	Mordaza, Conj.
14		13	 Ref. 13	1	Clam Assy	Ensemble de mâchoire	Mordaza, Conj.
15	3519689M1	13		2	Bushing	Bague	Anillo
16	6103657M1	13		2	Edge, Cutting	Lame d'attaque	Cuchilla de ataque
17	6106215M1	2	30 x 115 mm	2	Pin	Axe	Pasador
18	339891X1	2	M8 x 80	2	Screw	Vis	Tornillo
19	394367X1	2	M8	2	Nut, Lock	Écrou de blocage	Tuerca de retención
20		2	 66006C03.1 1	2	Cylinder	Cylindre	Cilindro
21	3517159M1	2	30 x 145 mm	2	Pin	Axe	Pasador
22	390246X1	2	M8 x 70	2	Bolt	Boulon	Perno
23	394367X1	2	M8	2	Nut, Lock	Écrou de blocage	Tuerca de retención



860 880 970 980
TX860B TX870B
TX970B

809 810 811 812 813 814 815 816 817 821 822 823 824 825 841 842 843 844 845
851 852 853 854 855 921 922 923 931 932

66006AC01.1

6199042M3

1

Jan-06

**Loader Bucket
Godet Chargeur
Cuchara cargadora**

**7 In 1
7 x 1
7 x 1**

**Bucket Pipework
Tuyauteries Godet
Tubazione di lavoro per benna**

AC-66006-02.1-A

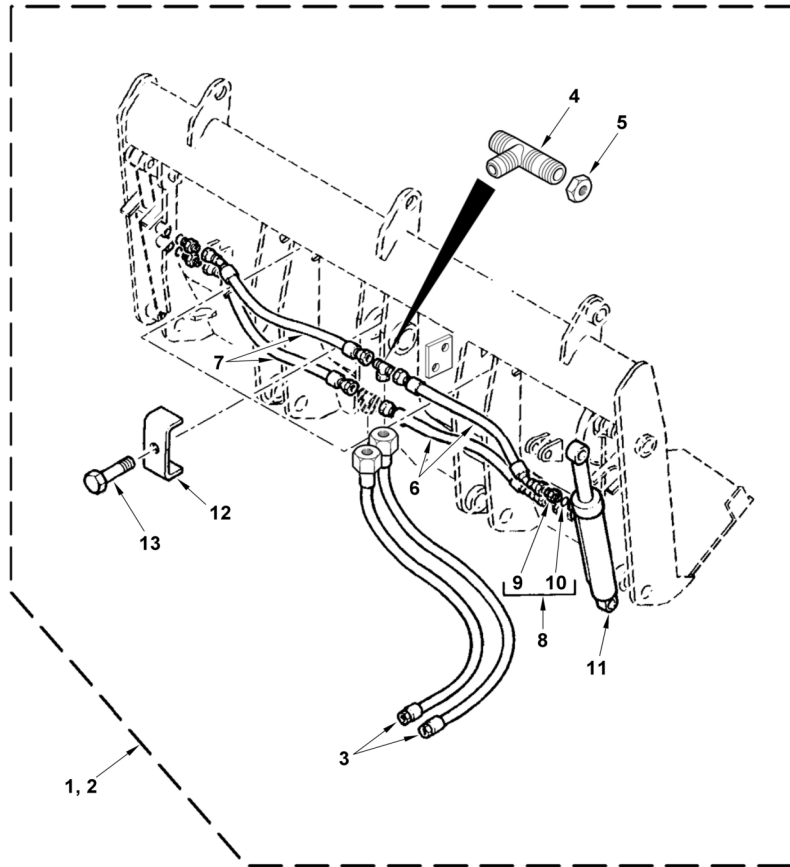

1	ACC42B		Continued Bucket & Blade	1	Accessory code	Code accessoire	Código accesorio
2	6106283M92	1	Continued 1.2m ³	1	Bucket 7 In 1	Godet 7 en 1	Cuchara - 7 X 1
3	6106214M91	2		2	Hose Assy	Ensemble de flexible	Flexible, Conj.
4	218-1236	2		2	Tee	Raccord en T	Te
5	356614X1	2		2	Nut, Lock	Écrou de blocage	Tuerca de retención
6	6106212M91	2		2	Hose Assy	Ensemble de flexible	Flexible, Conj.
7	6106213M91	2		2	Hose Assy	Ensemble de flexible	Flexible, Conj.
8	835091M91	2	9/16	4	Union	Union	Unión
9		8	➔ Ref. 8	1	Union	Union	Unión
10	831452M1	8		1	O-Ring	Joint torique	Junta de tipo O
11		2	👁 [66006C03.1 2]	2	Cylinder	Cylindre	Cilindro
12	3522094M2	2		3	Bracket, Clamp	Bride de fixation	Brida de fijación
13	339761X1	2	M8 x 25	3	Screw	Vis	Tornillo



860 880 970 980
TX860B TX870B
TX970B

809 810 811 812 813 814 815 816 817 821 822 823 824 825 841 842 843 844 845
851 852 853 854 855 921 922 923 931 932

66006AC02.1

6199042M3

1

Jan-06

Loader Bucket
Godet Chargeur
Cuchara cargadora

7 In 1
7 x 1
7 x 1

Cylinder
Cylindre
Cilindro

AC-66006-03.1-A

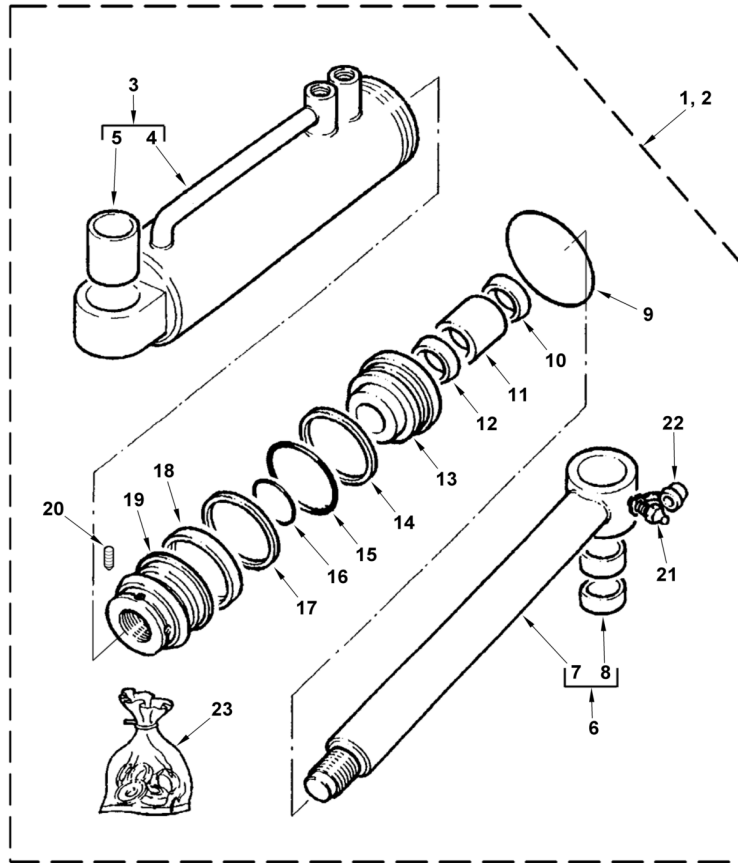

1	ACC42B		Bucket & Blade	1	Accessory code	Code accessoire	Código accesorio
2	6106632M91	1	● [66006C01.1 20] ● [66006C02.1 11]	2	Cylinder Assy	Ensemble de vérin	Gato, Conj.
3	5002708M91	2		1	Tube, Cylinder	Cylindre de vérin	Cilindro de gato
4		3	➤ Ref. 3	1	Tube, Cylinder	Cylindre de vérin	Cilindro de gato
5	5002510M1	3		1	Bushing	Bague	Anillo
6	5002711M91	2		1	Rod, Piston	Tige de vérin	Vástago cilindro
7		6	➤ Ref. 5	1	Rod, Piston	Tige de vérin	Vástago cilindro
8	5002717M1	6		2	Bushing	Bague	Anillo
9	3487205M1	2 (A)		1	O-Ring	Joint torique	Junta de tipo O
10	1605446M1	2 (A)		1	Wiper	Racleur	Raspador, Escobilla
11	3485978M1	2		1	Bearing, Gland	Coussinet de palier	Cojinete de palier
12	3485976M1	2 (A)		1	Seal	Joint	Junta
13	3624984M1	2		1	Gland, Cylinder	Palier de vérin	Palier de gato
14	1884170M1	2 (A)		1	Ring, Backup	Contre-joint	ContraJunta
15	359187X1	2 (A)		1	O-Ring	Joint torique	Junta de tipo O
16	3312583M1	2 (A)		1	O-Ring	Joint torique	Junta de tipo O
17	3485241M1	2 (A)		1	Ring	Anneau	Aro
18	3487067M1	2 (A)		1	Ring, Sealing	Bague d'étanchéité	Anillo, Estanqueidad
19	3624983M1	2		1	Piston	Piston	Pistón
20	3402928M1	2 (A)		1	Screw	Vis	Tornillo
21	365572X1	2		1	Fitting, Grease	Graisser	Engrasador
22	3516180M2	2		1	Cover	Cache	Tapa
23	6193231M91		(B)	1	Kit, Seal	Pochette de joints	Juego de juntas

A Included in kit marked (B)
Inclus dans jeu marqué (B)
Incluido en juego marcado (B)

B Contains items marked (A)
Comprend les pièces marquées (A)
Incluye las piezas marcadas (A)



860 880 970 980
TX860B TX870B
TX970B

809 810 811 812 813 814 815 816 817 821 822 823 824 825 841 842 843 844 845
851 852 853 854 855 921 922 923 931 932

66006AC03.1

6199042M3

1

Jan-06

**Loader Bucket
Godet Chargeur
Cuchara cargadora**

**7 In 1
7 x 1
7 x 1**

C-66006-01.1-A

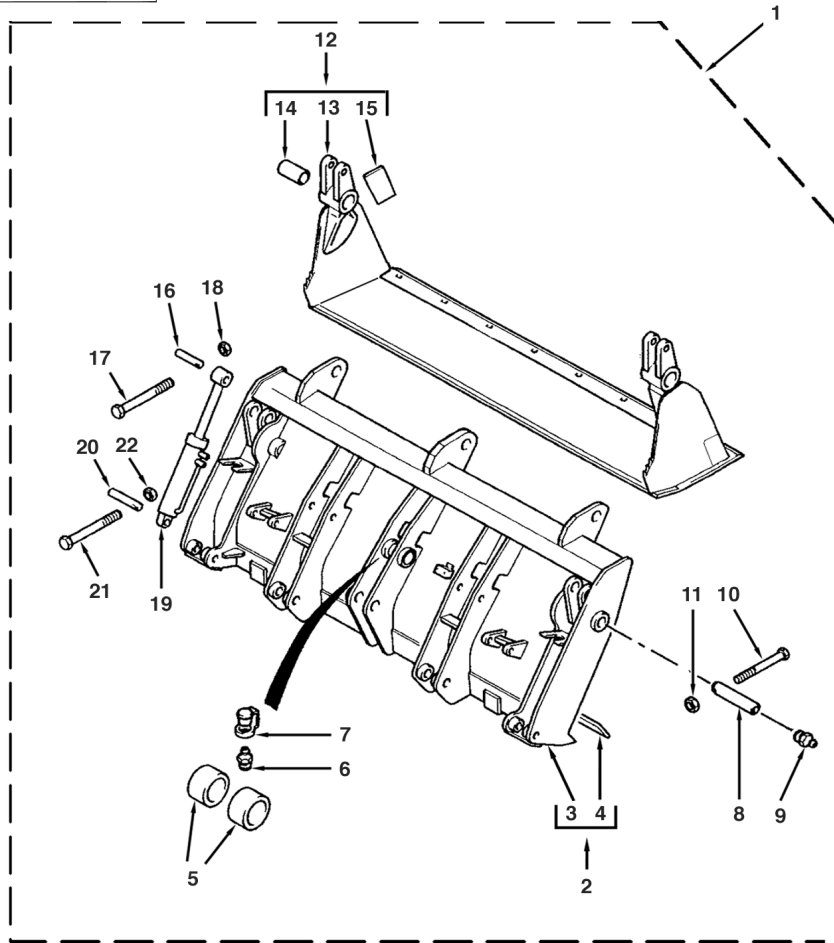

1	6106283M92		1.2m ³	1	Bucket 7 In 1	Godet 7 en 1	Cuchara - 7 X 1
2	6103620M92	1		1	Bucket 7 In 1	Godet 7 en 1	Cuchara - 7 X 1
4		2	Ref.2	1	Bucket	Godet	Cuchara
3	3519514M1	2	2386 mm	1	Blade, Dozer	Lame	Cuchilla
5	3520033M1	1		2	Bushing	Bague	Anillo
6	339608X1	1		1	Fitting, Grease	Graisser	Engrasador
7	3516180M2	1		1	Cover	Cache	Tapa
8	3507539M1	1	45 x 203 mm	2	Pin	Axe	Pasador
9	365572X1	1		2	Fitting, Grease	Graisser	Engrasador
10	3009504X1	1	M10 x 100	2	Screw	Vis	Tornillo
11	1440329X1	1	M10	2	Nut, Lock	Écrou de blocage	Tuerca de retención
12	6103647M92	1		1	Clam Assy	Ensemble de mâchoire	Mordaza, Conj.
13		12	Ref.12	1	Clam Assy	Ensemble de mâchoire	Mordaza, Conj.
14	3519689M1	12		2	Bushing	Bague	Anillo
15	6103657M1	12		2	Edge, Cutting	Lame d'attaque	Cuchilla de ataque
16	6106215M1	1	30 x 115 mm	2	Pin	Axe	Pasador
17	339891X1	1	M8 x 80	2	Screw	Vis	Tornillo
18	394367X1	1	M8	2	Nut, Lock	Écrou de blocage	Tuerca de retención
19		1	66006C03.1 1	2	Cylinder	Cylindre	Cilindro
20	3517159M1	1	30 x 145 mm	2	Pin	Axe	Pasador
21	390246X1	1	M8 x 70	2	Bolt	Boulon	Perno
22	394367X1	1	M8	2	Nut, Lock	Écrou de blocage	Tuerca de retención



860 880 970 980
TX860B TX870B
TX970B

809 810 811 812 813 814 815 816 817 821 822 823 824 825 841 842 843 844 845
851 852 853 854 855 921 922 923 931 932

66006C01.1

6199042M3

1

Jan-06

Loader Bucket
 Godet Chargeur
 Cuchara cargadora

7 In 1
 7 x 1
 7 x 1
 Bucket Pipework
 Tuyauteries Godet
 Tubazione di lavoro per benna

C-66006-02.1-A

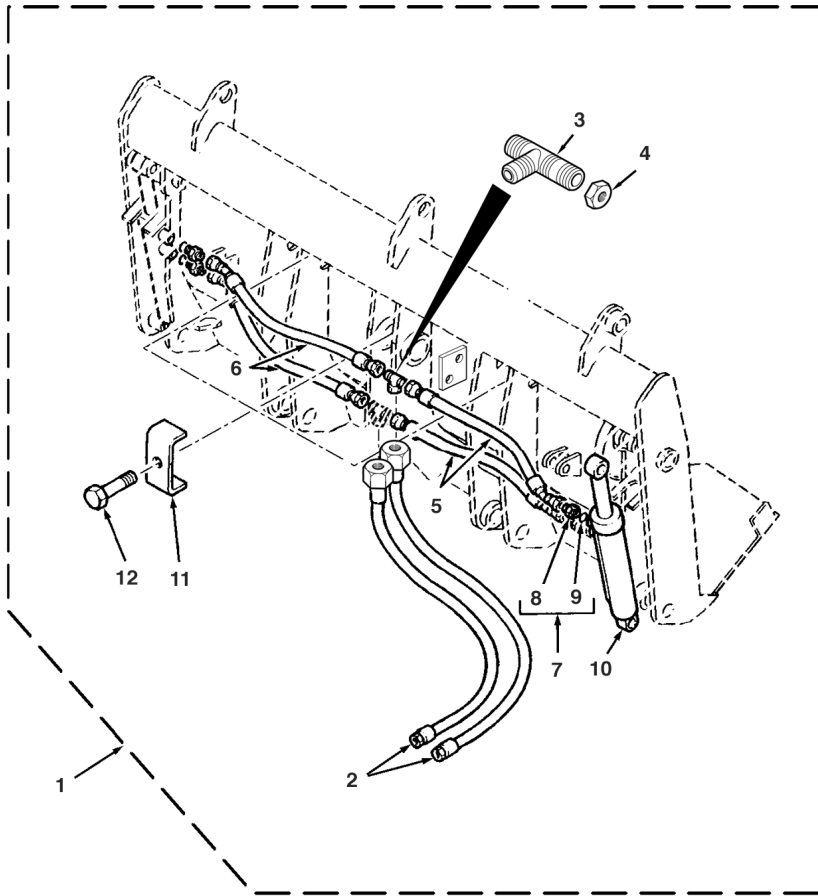

1	6106283M92		Continued 1.2m ³	1	Bucket 7 In 1	Godet 7 en 1	Cuchara - 7 X 1
2	6106214M91	1		2	Hose Assy	Ensemble de flexible	Flexible, Conj.
3	218-1236	1		2	Tee	Raccord en T	Te
4	356614X1	1		2	Nut, Lock	Écrou de blocage	Tuerca de retención
5	6106212M91	1		2	Hose Assy	Ensemble de flexible	Flexible, Conj.
6	6106213M91	1		2	Hose Assy	Ensemble de flexible	Flexible, Conj.
7	835091M91	1	9/16	4	Union	Union	Unión
8		7	Ref.7	1	Union	Union	Unión
9	831452M1	7		1	O-Ring	Joint torique	Junta de tipo O
10		1	66006C03.1 1	2	Cylinder	Cylindre	Cilindro
11	3522094M2	1		3	Bracket, Clamp	Bride de fixation	Brida de fijación
12	339761X1	1	M8 x 25	3	Screw	Vis	Tornillo



860 880 970 980
 TX860B TX870B
 TX970B

809 810 811 812 813 814 815 816 817 821 822 823 824 825 841 842 843 844 845
 851 852 853 854 855 921 922 923 931 932

66006C02.1

6199042M3

1

Jan-06

Loader Bucket
Godet Chargeur
Cuchara cargadora

7 In 1
7 x 1
7 x 1

Cylinder
Cylindre
Cilindro

C-66006-03.1-A

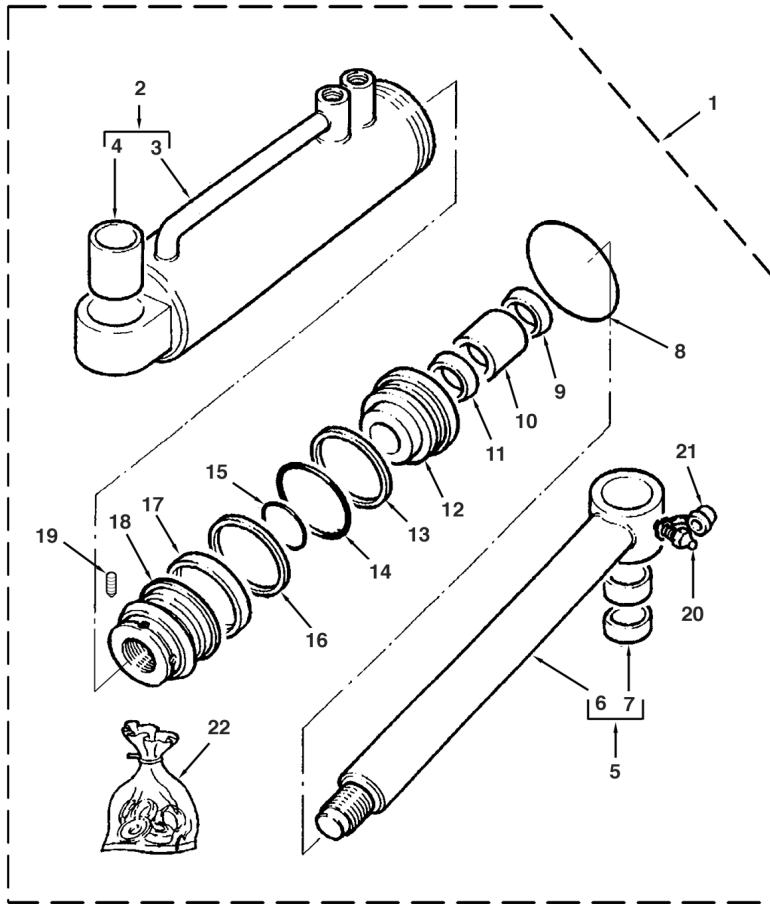

1	6106632M91	66006C01.1 19 66006C02.1 10	2	Cylinder Assy	Ensemble de vérin	Gato, Conj.
2	5002708M91	1	1	Tube, Cylinder	Cylindre de vérin	Cilindro de gato
3		2	1	Tube, Cylinder	Cylindre de vérin	Cilindro de gato
4	5002510M1	2	1	Bushing	Bague	Anillo
5	5002711M91	1	1	Rod, Piston	Tige de vérin	Vástago cilindro
6		5	1	Rod, Piston	Tige de vérin	Vástago cilindro
7	5002717M1	5	2	Bushing	Bague	Anillo
8	3487205M1	1 (A)	1	O-Ring	Joint torique	Junta de tipo O
9	1605446M1	1 (A)	1	Wiper	Racleur	Raspador, Escobilla
10	3485978M1	1	1	Bearing, Gland	Coussinet de palier	Cojinete de palier
11	3485976M1	1 (A)	1	Seal	Joint	Junta
12	3624984M1	1	1	Gland, Cylinder	Palier de vérin	Palier de gato
13	1884170M1	1 (A)	1	Ring, Backup	Contre-joint	Contrajunta
14	359187X1	1 (A)	1	O-Ring	Joint torique	Junta de tipo O
15	3312583M1	1 (A)	1	O-Ring	Joint torique	Junta de tipo O
16	3485241M1	1 (A)	1	Ring	Anneau	Aro
17	3487067M1	1 (A)	1	Ring, Sealing	Bague d'étanchéité	Anillo, Estanqueidad
18	3624983M1	1	1	Piston	Piston	Pistón
19	3402928M1	1 (A)	1	Screw	Vis	Tornillo
20	365572X1	1	1	Fitting, Grease	Graisser	Engrasador
21	3516180M2	1	1	Cover	Cache	Tapa
22	6193231M91	(B)	1	Kit, Seal	Pochette de joints	Juego de juntas

A Included in kit marked (B)
Inclus dans jeu marqué (B)
Incluido en juego marcado (B)

B Contains items marked (A)
Comprend les pièces marquées (A)
Incluye las piezas marcadas (A)



860 880 970 980
TX860B TX870B
TX970B

809 810 811 812 813 814 815 816 817 821 822 823 824 825 841 842 843 844 845
851 852 853 854 855 921 922 923 931 932

66006C03.1

6199042M3

1

Jan-06

Loader Bucket
Godet Chargeur
Cuchara cargadora

Standard
Standard
Estándar

For Use With Forks
 Utilise avec Fourchette
 Para uso con horquillas

AC-66003-01.1-A

1	ACC41A		Bucket & Blade	1	Accessory code	Code accessoire	Código accesorio
2	6108216M91	1	1.0m ³	1	Bucket Assy	Ensemble de godet	Cuchara, Conj.
3		2	 Ref.2	1	Bucket	Godet	Cuchara
4	6103468M1	2	1.0m ³ bucket 2310 mm	1	Blade, Dozer	Lame	Cuchilla
5	3516180M2	2		1	Cover	Cache	Tapa
6	339608X1	2		1	Fitting, Grease	Graisseur	Engrasador
7	3520033M1	2		2	Bushing	Bague	Anillo
8	6103458M1	2		2	Edge, Cutting	Lame d'attaque	Cuchilla de ataque

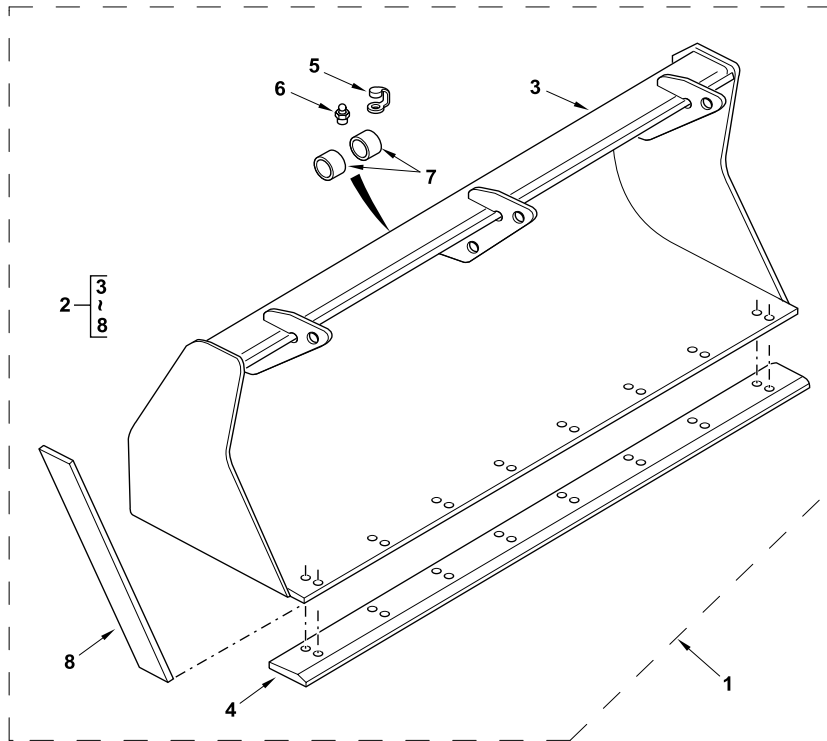

820 860 880
 TX760B TX860B
 TX870B

801 802 803 804 805 806 807 808 809 810 811 812 813 814 815 816 817 821 822
 823 824 825 831 832 833 834 841 842 843 845 851 852 853 854 855

66003AC01.1

6199042M3

1

Jan-06

Loader Bucket
Godet Chargeur
Cuchara cargadora

Standard
Standard
Estándar

For Use With Forks
 Utilise avec Fourchette
 Para uso con horquillas

C-66003-01.1-A

1	6108216M91		1.0m³	1	Bucket Assy	Ensemble de godet	Cuchara, Conj.
2		1	 Ref.1	1	Bucket	Godet	Cuchara
3	6103468M1	1	1.0m³ bucket 2310 mm	1	Blade, Dozer	Lame	Cuchilla
4	3516180M2	1		1	Cover	Cache	Tapa
5	339608X1	1		1	Fitting, Grease	Graisneur	Engrasador
6	3520033M1	1		2	Bushing	Bague	Anillo
7	6103458M1	1		2	Edge, Cutting	Lame d'attaque	Cuchilla de ataque

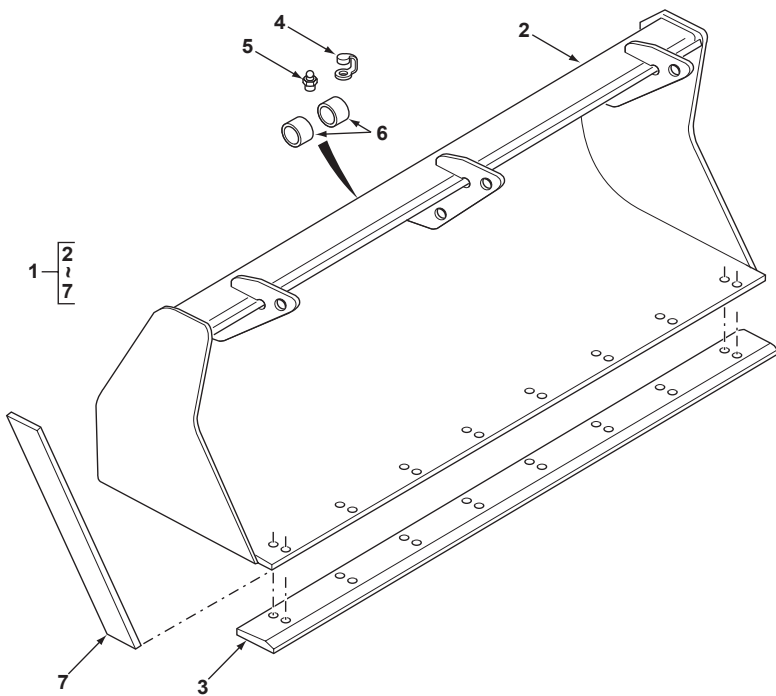

820 860 880
 TX760B TX860B
 TX870B

801 802 803 804 805 806 807 808 809 810 811 812 813 814 815 816 817 821 822
 823 824 825 831 832 833 834 841 842 843 845 851 852 853 854 855

66003C01.1

6199042M3

1

Jan-06

Loader Bucket
Godet Chargeur
Cuchara cargadora

Standard
Standard
Estándar

For Use With Forks
 Utilise avec Fourchette
 Para uso con horquillas

AC-66004-01.1-A

1	ACC41B		Bucket & Blade	1	Accessory code	Code accessoire	Código accesorio
2	6108217M91	1	1.2m ³	1	Bucket Assy	Ensemble de godet	Cuchara, Conj.
3		2	 Ref.3	1	Bucket	Godet	Cuchara
4	6103440M1	2	1.2m ³ bucket 2386 mm	1	Blade, Dozer	Lame	Cuchilla
5	3516180M2	2		1	Cover	Cache	Tapa
6	339608X1	2		1	Fitting, Grease	Graisseur	Engrasador
7	3520033M1	2		2	Bushing	Bague	Anillo
8	6103458M1	2		2	Edge, Cutting	Lame d'attaque	Cuchilla de ataque

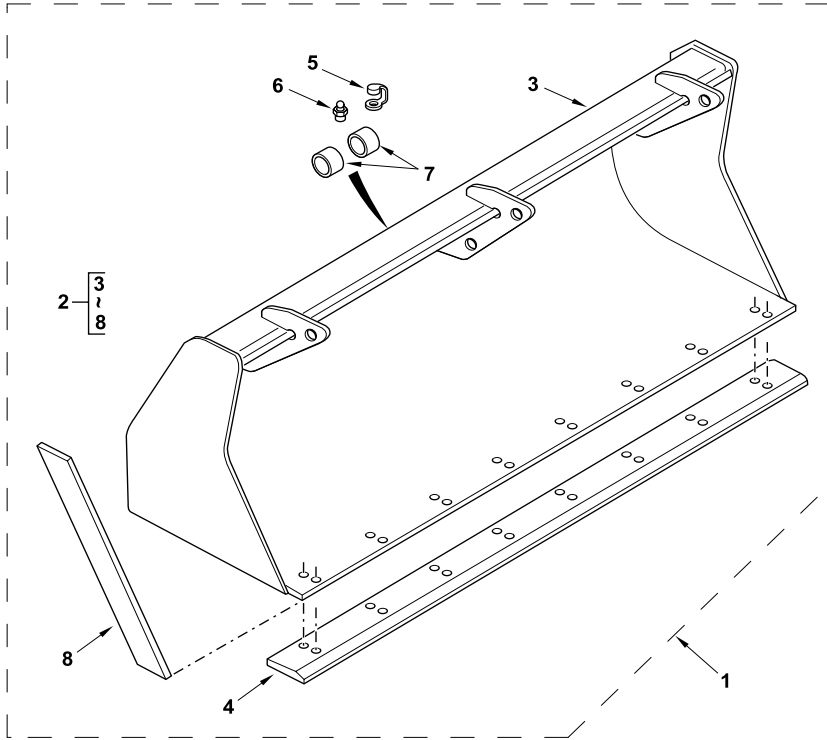

860 880 970 980
 TX860B TX870B
 TX970B

809 810 811 812 813 814 815 816 817 821 822 823 824 825 841 842 843 844 845
 851 852 853 854 855 921 922 923 931 932

66004AC01.1

6199042M3

1

Jan-06

Loader Bucket
Godet Chargeur
Cuchara cargadora

Standard
Standard
Estándar

For Use With Forks
 Utilise avec Fourchette
 Para uso con horquillas

C-66004-01.1-A

1	6108217M91		1.2m³	1	Bucket Assy	Ensemble de godet	Cuchara, Conj.
2		1	 Ref.1	1	Bucket	Godet	Cuchara
3	6103440M1	1	1.2m³ bucket 2386 mm	1	Blade, Dozer	Lame	Cuchilla
4	3516180M2	1		1	Cover	Cache	Tapa
5	339608X1	1		1	Fitting, Grease	Graisneur	Engrasador
6	3520033M1	1		2	Bushing	Bague	Anillo
7	6103458M1	1		2	Edge, Cutting	Lame d'attaque	Cuchilla de ataque

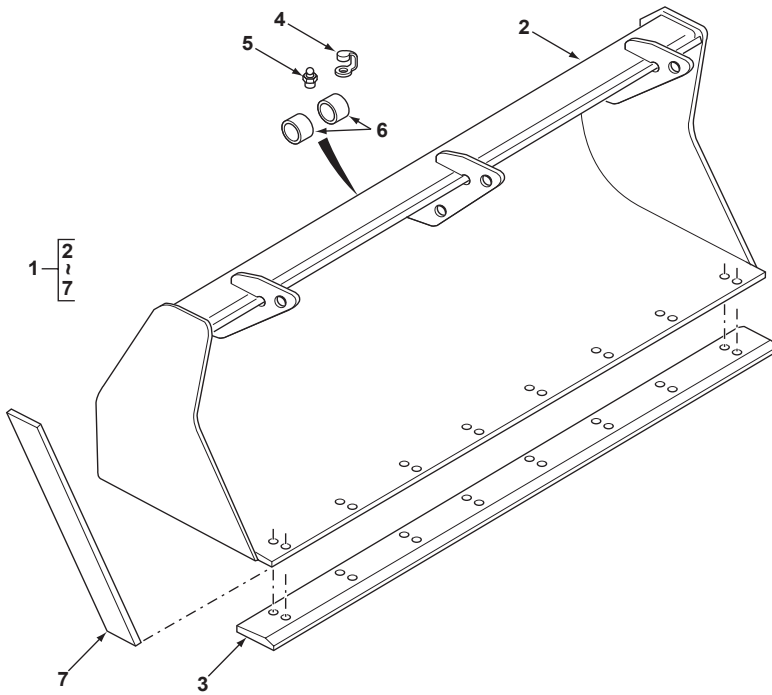

860 880 970 980
 TX860B TX870B
 TX970B

809 810 811 812 813 814 815 816 817 821 822 823 824 825 841 842 843 844 845
 851 852 853 854 855 921 922 923 931 932

66004C01.1

6199042M3

1

Jan-06

C - Digger Quick Attach • Dispositif de fixation rapide pour bras de pelle • Enganche rápido de la excavadora

Quick Attach, Digger - Sideshift.....	90003C03.1	Accouplement Rapide - Montage de Pelle Latéral	Acoplamiento rápido - Excavadora de montaje horizontal
Quick Attach, Digger - Sideshift.....	90003C04.1	Accouplement Rapide - Montage de Pelle Latéral	Acoplamiento rápido - Excavadora de montaje horizontal
Quick Attach, Digger - Sideshift.....	90004C01.1	Accouplement Rapide - Montage de Pelle Latéral	Acoplamiento rápido - Excavadora de montaje horizontal
Quick Attach, Digger - Sideshift.....	90004C02.1	Accouplement Rapide - Montage de Pelle Latéral	Acoplamiento rápido - Excavadora de montaje horizontal
Quick Attach, Digger - Sideshift.....	90004C03.1	Accouplement Rapide - Montage de Pelle Latéral	Acoplamiento rápido - Excavadora de montaje horizontal
Quick Attach, Digger - Sideshift.....	90011C01.1	Accouplement Rapide - Montage de Pelle Latéral	Acoplamiento rápido - Excavadora de montaje horizontal
Quick Attach, Digger - Sideshift.....	90011C02.1	Accouplement Rapide - Montage de Pelle Latéral	Acoplamiento rápido - Excavadora de montaje horizontal
Quick Attach, Digger - Sideshift.....	90011C03.1	Accouplement Rapide - Montage de Pelle Latéral	Acoplamiento rápido - Excavadora de montaje horizontal
Quick Attach, Digger - Sideshift.....	90012C01.1	Accouplement Rapide - Montage de Pelle Latéral	Acoplamiento rápido - Excavadora de montaje horizontal
Quick Attach, Digger - Sideshift.....	90012C02.1	Accouplement Rapide - Montage de Pelle Latéral	Acoplamiento rápido - Excavadora de montaje horizontal
Quick Attach, Digger - Sideshift.....	90012C03.1	Accouplement Rapide - Montage de Pelle Latéral	Acoplamiento rápido - Excavadora de montaje horizontal



Quick Attach, Digger
 Accouplement Rapide, Défonceuse
 Acoplamiento rápido

Abiljo
 Abiljo
 Abiljo

C-90017-01.1-A

1	6110753M91	(A) Spring Lock	1	Hitch Assy, Quick	Ensem. D'attel. Rapide	Engan. rápido, Conj.
---	------------	--------------------	---	-------------------	------------------------	----------------------

A Details to be advised
 Détails à demander
 Detalles que deben ser notificados

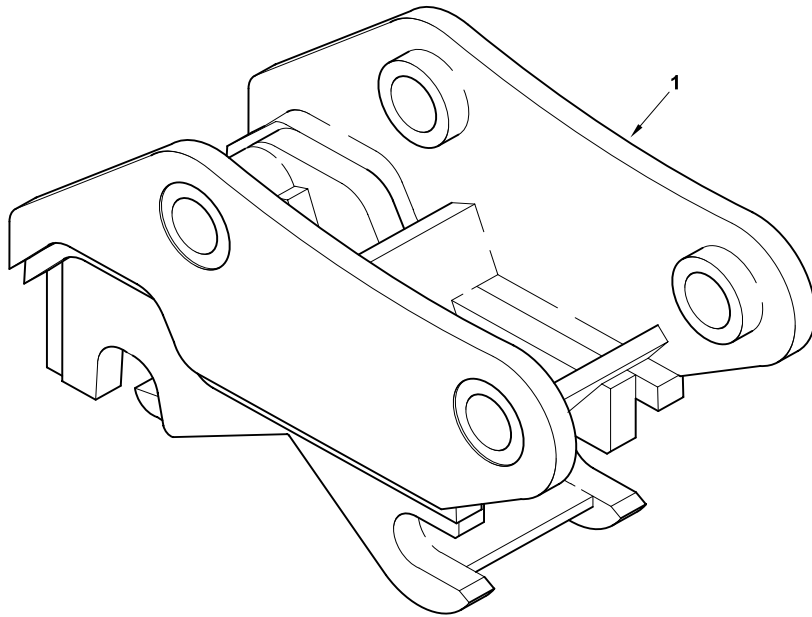

880 980
 TX760B TX860B
 TX870B TX970B

831 832 833 834 841 842 843 844 845 851 852 853 854 855 932

Quick Attach, Digger
Accouplement Rapide
Acoplamiento rápido

Centremount
Montage de Pelle
Excavadora de montaje central

Standard Dipper - Boom 4.5m
 Balancier Standard - Flèche 4.5m
 Balancín estándar - Pluma 4.5m

Miller
 Miller
 Miller

C-90005-01.1-A

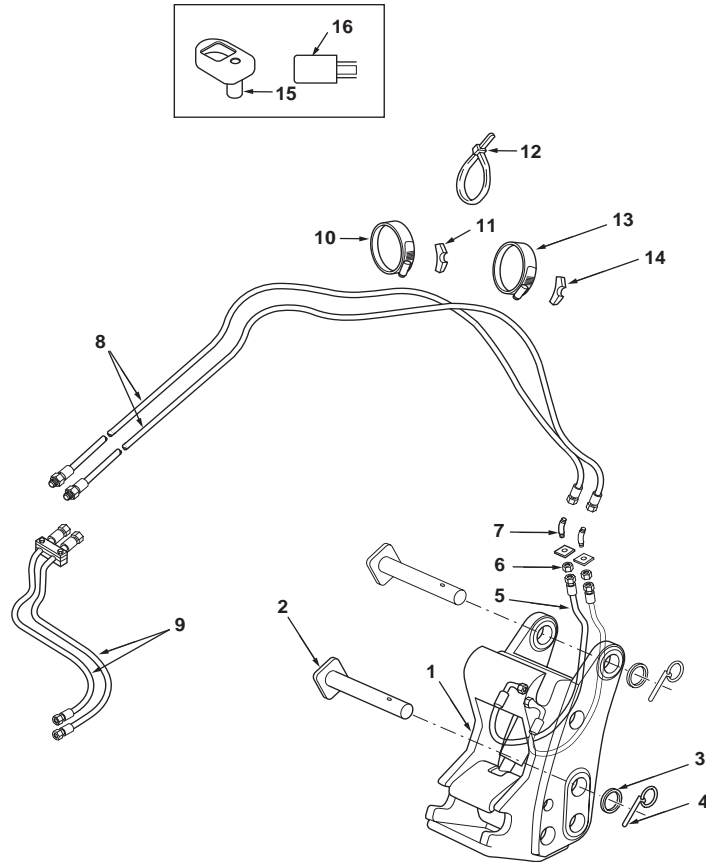

1	6108811M92	90005C04.1 1	1	Hitch Assy, Quick	Ensem. D'attel. Rapide	Engan. rápido, Conj.
2	3516519M94	45 x 302 mm	2	Pin	Axe	Pasador
3	3501790M1		2	Washer	Rondelle	Arandela
4	3516522M91		2	Pin, Linch	Goupille d'arrêt	Pasador de parada
5	6102923M91		2	Hose Assy	Ensemble de flexible	Flexible, Conj.
6	356612X1	7/16" UNF	2	Nut	Écrou	Tuerca
7	371089X1		2	Elbow, 45°	Coude à 45°	Codo, 45°
8	6106086M91		2	Hose Assy	Ensemble de flexible	Flexible, Conj.
9		90005C02.1 11	2	Hose Assy	Ensemble de flexible	Flexible, Conj.
10	3517732M1		1	Clip, Mounting	Collier de fixation	Argolla de fijación
11	D142787		1	Mount, Rubber	Support caoutchouc	Bloque de caucho
12	1664405M1		6	Tie, Cable	Attache câble	Enlace de Cable
13	3517731M1		1	Clip, Mounting	Collier de fixation	Argolla de fijación
14	D142787		1	Mount, Rubber	Support caoutchouc	Bloque de caucho
15	6101777M91	Switch	1	Cover	Cache	Tapa
16	6102490M1		1	Relay	Relais	Relé



820 860 880 970
 TX760B TX860B

801 802 803 804 813 814 821 822 831 832 841 842 851 852 922

90005C01.1

6199042M3

1

Jan-06

Quick Attach, Digger
Accouplement Rapide
Acoplamiento rápido

Centremount
Montage de Pelle
Excavadora de montaje central

Standard Dipper - Boom 4.5m
 Balancier Standard - Flèche 4.5m
 Balancín estándar - Pluma 4.5m

Miller
 Miller
 Miller

C-90005-02.1-A

1	365830X91		1	Union	Union	Unión
2		1  Ref. 1	1	Union	Union	Unión
3		1	1	O-Ring	Joint torique	Junta de tipo O
4	6109910M91	Q/A Feed	1	Hose Assy	Ensemble de flexible	Flexible, Conj.
5	6106011M91	90005C03.1 1	1	Valve, Solenoid	Électrovalve	Electroválvula
6	391244X1	M6 x 45	2	Bolt	Boulon	Perno
7	1441500X1	M6	2	Nut, Lock	Écrou de blocage	Tuerca de retención
8	370807X91		2	Elbow, 90°	Coude à 90°	Codo, 90°
9		8  Ref. 8	1	Elbow	Coude	Codo
10	831452M1	8	1	O-Ring	Joint torique	Junta de tipo O
11	3519882M92		2	Hose Assy	Ensemble de flexible	Flexible, Conj.
12	365065X91		2	Union	Union	Unión
13		12  Ref. 12	1	Union	Union	Unión
14	831452M1	12	1	O-Ring	Joint torique	Junta de tipo O
15	3519226M91	Q/A Return	1	Hose Assy	Ensemble de flexible	Flexible, Conj.

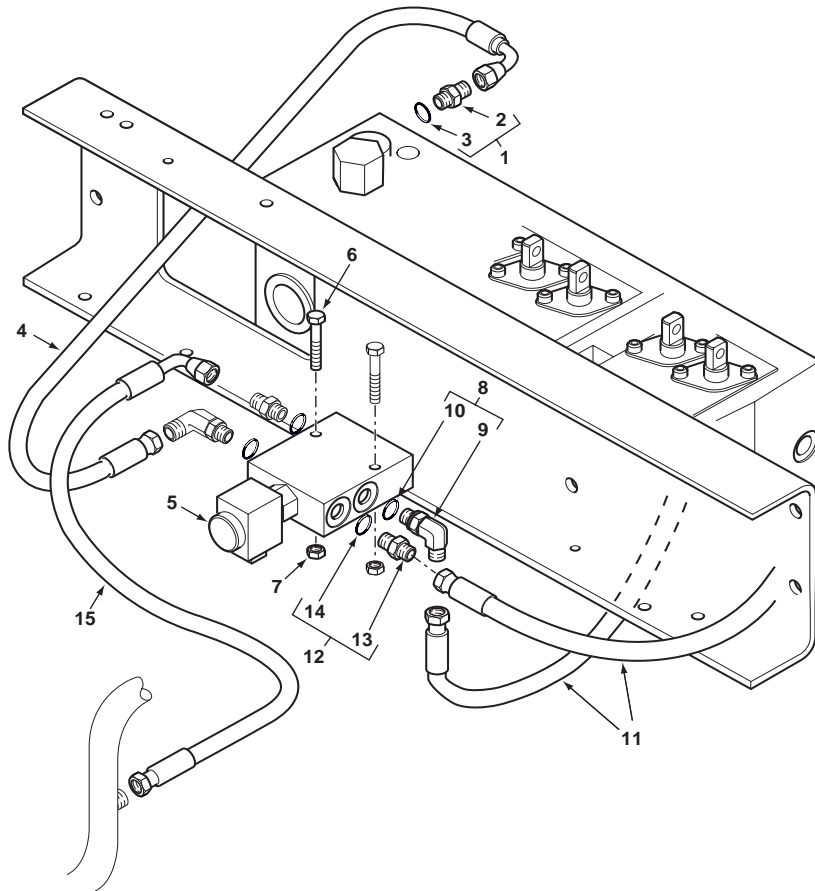

820 860 880 970
 TX760B TX860B

801 802 803 804 813 814 821 822 831 832 841 842 851 852 922

90005C02.1

6199042M3

1

Jan-06

Quick Attach, Digger
Accouplement Rapide
Acoplamiento rápido

Centremount
Montage de Pelle
Excavadora de montaje central

Solenoid Valve
Électrovanne
Electroválvula

C-90005-03.1-A

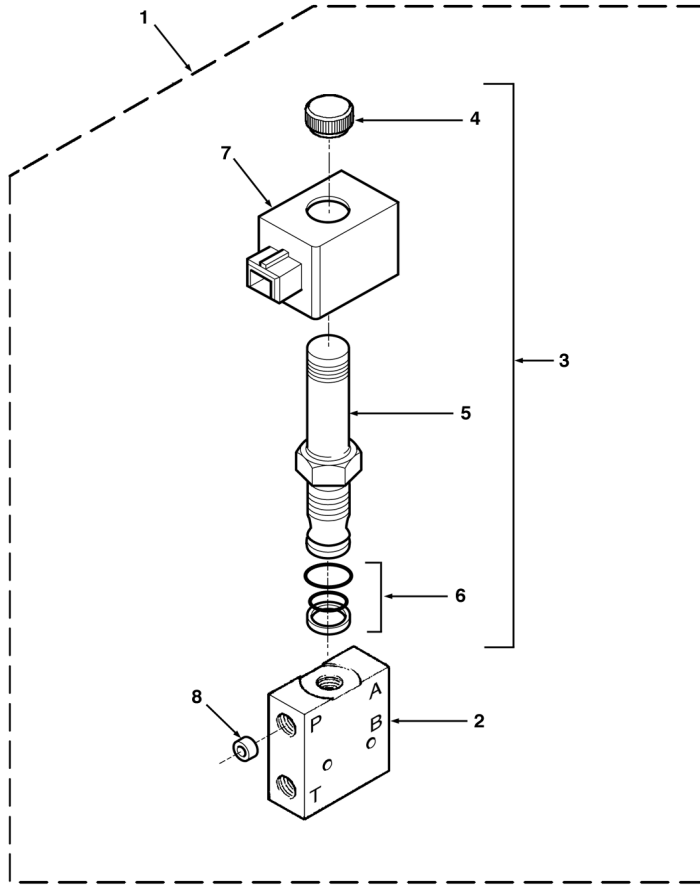

1	6106011M91		90005C02.1 5	1	Valve, Solenoid	Électrovalve	Electroválvula
2		1	Ref. 1	1	Body	Corps	Cuerpo
3	6193020M91	1		1	Solenoid Assy	Ensemble de solénoïde	Solenoïde, Conj.
4		3	Ref. 3	1	Nut	Écrou	Tuerca
5		3	Ref. 3	1	Cartridge	Cartouche	Cartucho
6	6193022M91	3		1	Kit, Seal	Pochette de joints	Juego de juntas
7	6191096M91	1	12V	1	Coil	Bobine	Bobina
8	6193021M1	1		1	Restrictor	Réduction	Reducción



820 860 880 970
TX760B TX860B

801 802 803 804 813 814 821 822 831 832 841 842 851 852 922

90005C03.1

6199042M3

1

Jan-06

Quick Attach, Digger
Accouplement Rapide
Acoplamiento rápido

Centremount
Montage de Pelle
Excavadora de montaje central

Quick Coupler
Attache Rapide
Acoplamiento rápido

Miller
 Miller
 Miller

C-90005-04.1-A

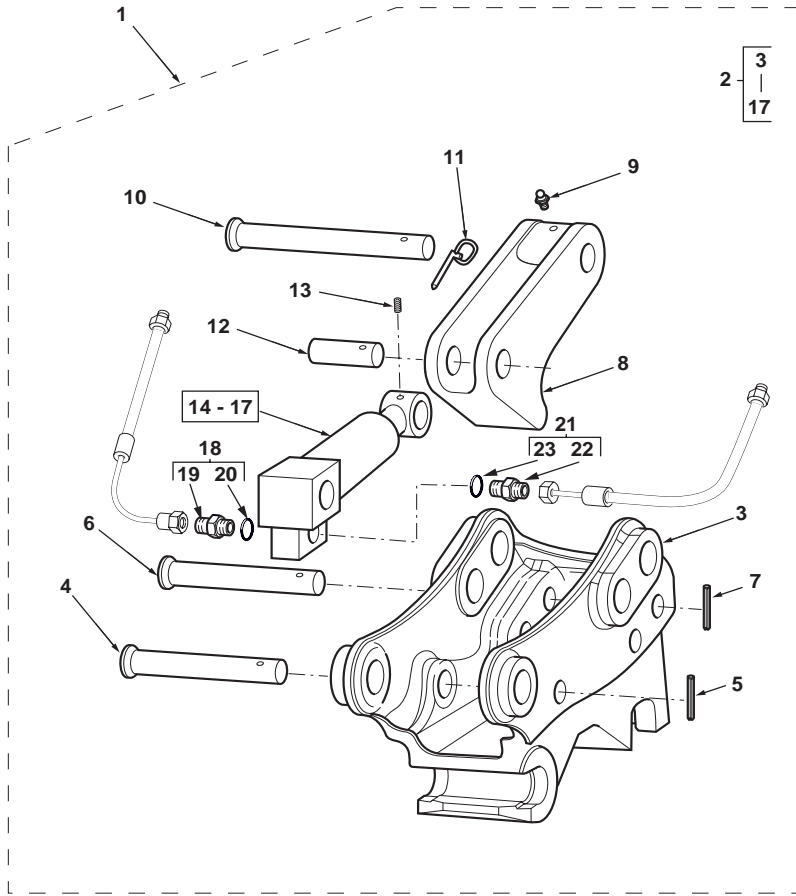

1	6108811M92			1	Hitch Assy, Quick	Ensem. D'attel. Rapide	Engan. rápido, Conj.
2	6102976M91	1		1	Hitch Assy, Quick	Ensem. D'attel. Rapide	Engan. rápido, Conj.
3	6193009M1	2		1	Body	Corps	Cuerpo
4	6193013M1	2	25 x 240 mm	1	Pin	Axe	Pasador
5	6193016M1	2		1	Pin, Roll	Goupille élastique	Pasador elástico
6	6193012M1	2	32 x 240 mm	1	Pin	Axe	Pasador
7	6193016M1	2		1	Pin, Roll	Goupille élastique	Pasador elástico
8	6193010M1	2		1	Hook	Crochet	Gancho
9	6193018M1	2		1	Fitting, Grease	Graisneur	Engrasador
10	6193015M1	2	32 x 240 mm	1	Pin	Axe	Pasador
11	6193017M1	2		1	Pin, Linch	Goupille d'arrêt	Pasador de parada
12	6193014M1	2	25 x 100 mm	1	Pin	Axe	Pasador
13	6193019M1	2		1	Screw	Vis	Tornillo
14	6193011M91	2		1	Cylinder Assy	Ensemble de vérin	Gato, Conj.
15	6193577M91	14	(A)	1	Valve, Check	Clapet anti-retour	Válvula de parada
16	6193578M91	14	(A) Check Valve	1	Kit, Seal	Pochette de joints	Juego de juntas
17	6193576M91	14	(A) Q/A Hyd. Cyl.	1	Kit, Seal	Pochette de joints	Juego de juntas
18	358741X91	1		1	Union	Union	Unión
19		18	➡ Ref. 18	1	Union	Union	Unión
20	831495M1	18		1	O-Ring	Joint torique	Junta de tipo O
21	6106088M91	1		1	Union	Union	Unión
22		21	➡ Ref. 21	1	Union	Union	Unión
23		21		1	O-Ring	Joint torique	Junta de tipo O

A Not illustrated
 Non illustrée
 No ilustrado



820 860 880 970
 TX760B TX860B

801 802 803 804 813 814 821 822 831 832 841 842 851 852 922

90005C04.1

6199042M3

1

Jan-06

Quick Attach, Digger
Accouplement Rapide
Acoplamiento rápido

Centremount
Montage de Pelle
Excavadora de montaje central

Standard Dipper - Boom 4.9m
 Balancier Standard - Flèche 4.9m
 Balancín estándar - Pluma 4.9m

Miller
 Miller
 Miller

C-90006-01.1-A

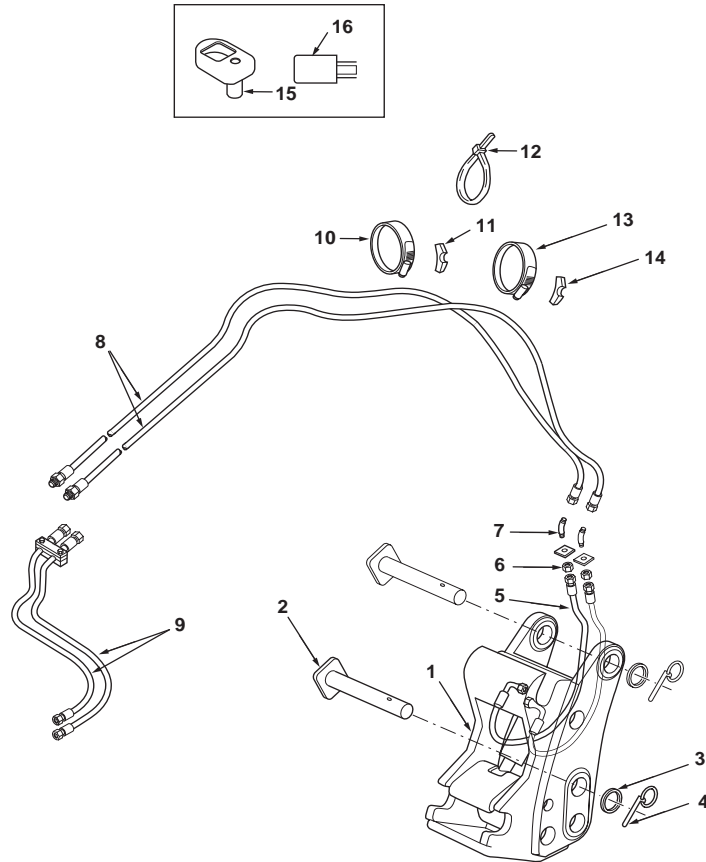

1	6108811M92	90006C04.1 1	1	Hitch Assy, Quick	Ensem. D'attel. Rapide	Engan. rápido, Conj.
2	3516519M94	45 x 302 mm	2	Pin	Axe	Pasador
3	3501790M1		2	Washer	Rondelle	Arandela
4	3516522M91		2	Pin, Linch	Goupille d'arrêt	Pasador de parada
5	6102923M91		2	Hose Assy	Ensemble de flexible	Flexible, Conj.
6	356612X1	7/16" UNF	2	Nut	Écrou	Tuerca
7	371089X1		2	Elbow, 45°	Coude à 45°	Codo, 45°
8	6106087M91		2	Hose Assy	Ensemble de flexible	Flexible, Conj.
9		90006C02.1 11	2	Hose Assy	Ensemble de flexible	Flexible, Conj.
10	3517732M1		1	Clip, Mounting	Collier de fixation	Argolla de fijación
11	D142787		1	Mount, Rubber	Support caoutchouc	Bloque de cauco
12	1664405M1		6	Tie, Cable	Attache câble	Enlace de Cable
13	3517731M1		1	Clip, Mounting	Collier de fixation	Argolla de fijación
14	D142787		1	Mount, Rubber	Support caoutchouc	Bloque de cauco
15	6101777M91	Switch	1	Cover	Cache	Tapa
16	6102490M1		1	Relay	Relais	Relé



860 880 970 980
 TX870B TX970B

815 816 823 824 843 844 853 854 923 932

90006C01.1

6199042M3

1

Jan-06





Quick Attach, Digger
Accouplement Rapide
Acoplamiento rápido

Centremount
Montage de Pelle
Excavadora de montaje central

Standard Dipper - Boom 4.9m
 Balancier Standard - Flèche 4.9m
 Balancín estándar - Pluma 4.9m

Miller
 Miller
 Miller

C-90006-02.1-A

1	365830X91		1	Union	Union	Unión
2		1  Ref. 1	1	Union	Union	Unión
3		1	1	O-Ring	Joint torique	Junta de tipo O
4	6109910M91	Q/A Feed	1	Hose Assy	Ensemble de flexible	Flexible, Conj.
5	6106011M91	 90006C03.1 1	1	Valve, Solenoid	Électrovalve	Electroválvula
6	391244X1	M6 x 45	2	Bolt	Boulon	Perno
7	1441500X1	M6	2	Nut, Lock	Écrou de blocage	Tuerca de retención
8	370807X91		2	Elbow, 90°	Coude à 90°	Codo, 90°
9		8  Ref. 8	1	Elbow	Coude	Codo
10	831452M1	8	1	O-Ring	Joint torique	Junta de tipo O
11	3519882M92		2	Hose Assy	Ensemble de flexible	Flexible, Conj.
12	365065X91		2	Union	Union	Unión
13		12  Ref. 12	1	Union	Union	Unión
14	831452M1	12	1	O-Ring	Joint torique	Junta de tipo O
15	3519226M91	Q/A Return	1	Hose Assy	Ensemble de flexible	Flexible, Conj.

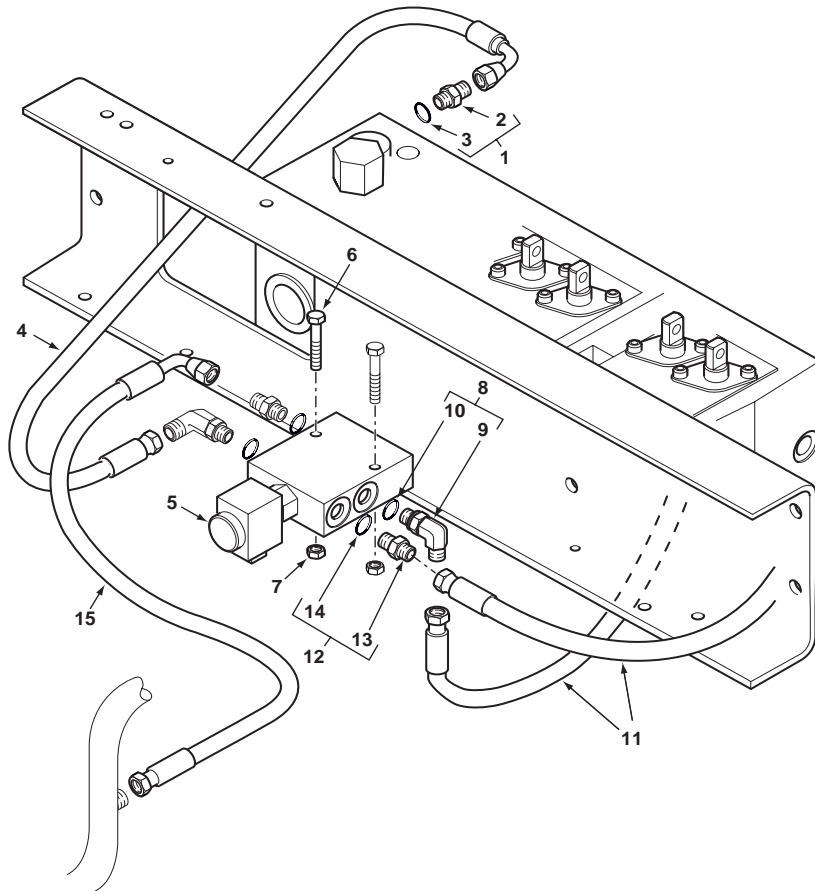

860 880 970 980
 TX870B TX970B

815 816 823 824 843 844 853 854 923 932

90006C02.1

6199042M3

1

Jan-06

Quick Attach, Digger
Accouplement Rapide
Acoplamiento rápido

Centremount
Montage de Pelle
Excavadora de montaje central

Solenoid Valve
Électrovanne
Electroválvula

C-90006-03.1-A

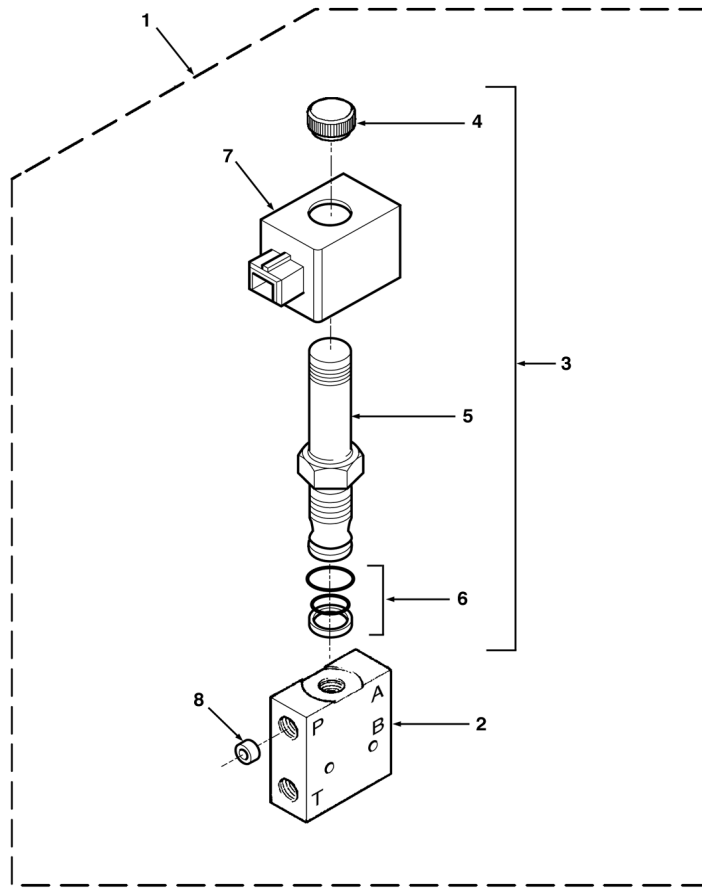

1	6106011M91		90006C02.1 5	1	Valve, Solenoid	Électrovalve	Electroválvula
2		1	Ref. 1	1	Body	Corps	Cuerpo
3	6193020M91	1		1	Solenoid Assy	Ensemble de solénoïde	Solenoïde, Conj.
4		3	Ref. 3	1	Nut	Écrou	Tuerca
5		3	Ref. 3	1	Cartridge	Cartouche	Cartucho
6	6193022M91	3		1	Kit, Seal	Pochette de joints	Juego de juntas
7	6191096M91	1	12V	1	Coil	Bobine	Bobina
8	6193021M1	1		1	Restrictor	Réduction	Reducción



860 880 970 980
TX870B TX970B

815 816 823 824 843 844 853 854 923 932

90006C03.1

6199042M3

1

Jan-06

Quick Attach, Digger
Accouplement Rapide
Acoplamiento rápido

Centremount
Montage de Pelle
Excavadora de montaje central

Quick Coupler
Attache Rapide
Acoplamiento rápido

Miller
 Miller
 Miller

C-90006-04.1-A

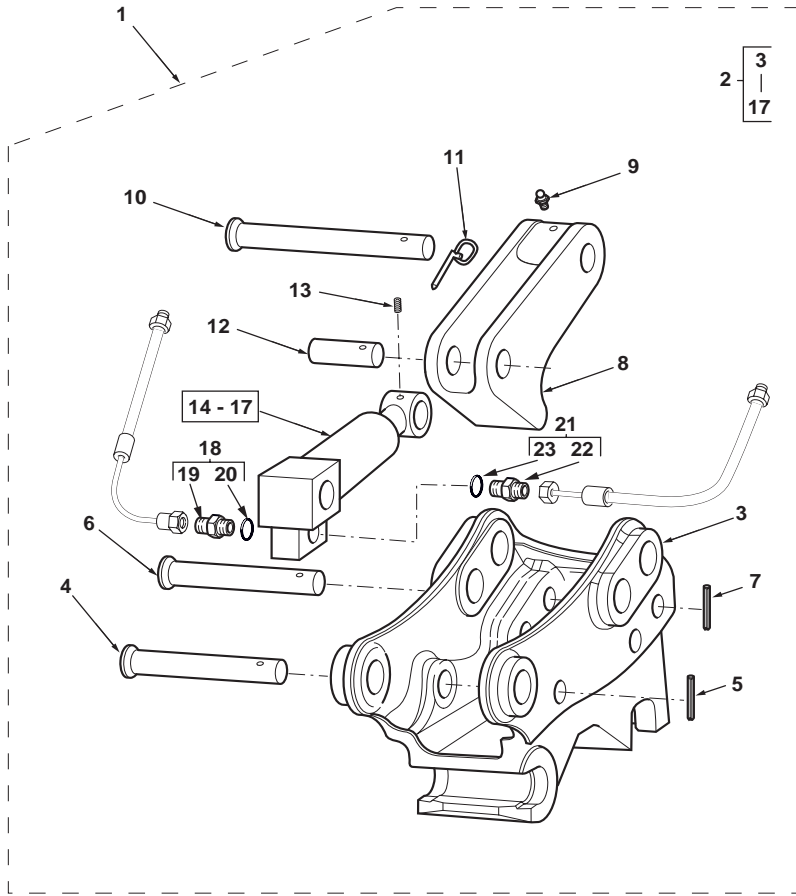

1	6108811M92			1	Hitch Assy, Quick	Ensem. D'attel. Rapide	Engan. rápido, Conj.
2	6102976M91	1		1	Hitch Assy, Quick	Ensem. D'attel. Rapide	Engan. rápido, Conj.
3	6193009M1	2		1	Body	Corps	Cuerpo
4	6193013M1	2	25 x 240 mm	1	Pin	Axe	Pasador
5	6193016M1	2		1	Pin, Roll	Goupille élastique	Pasador elástico
6	6193012M1	2	32 x 240 mm	1	Pin	Axe	Pasador
7	6193016M1	2		1	Pin, Roll	Goupille élastique	Pasador elástico
8	6193010M1	2		1	Hook	Crochet	Gancho
9	6193018M1	2		1	Fitting, Grease	Graisneur	Engrasador
10	6193015M1	2	32 x 240 mm	1	Pin	Axe	Pasador
11	6193017M1	2		1	Pin, Linch	Goupille d'arrêt	Pasador de parada
12	6193014M1	2	25 x 100 mm	1	Pin	Axe	Pasador
13	6193019M1	2		1	Screw	Vis	Tornillo
14	6193011M91	2		1	Cylinder Assy	Ensemble de vérin	Gato, Conj.
15	6193577M91	4	(A)	1	Valve, Check	Clapet anti-retour	Válvula de parada
16	6193578M91	4	(A)	1	Check Valve	Pochette de joints	Juego de juntas
17	6193576M91	4	(A)	1	Q/A Hyd. Cyl.	Pochette de joints	Juego de juntas
18	358741X91	1		1	Union	Union	Unión
19		18	➡ Ref. 18	1	Union	Union	Unión
20	831495M1	18		1	O-Ring	Joint torique	Junta de tipo O
21	6106088M91	1		1	Union	Union	Unión
22		21	➡ Ref. 21	1	Union	Union	Unión
23		21		1	O-Ring	Joint torique	Junta de tipo O

A Not illustrated
 Non illustrée
 No ilustrado



860 880 970 980
 TX870B TX970B

815 816 823 824 843 844 853 854 923 932

90006C04.1

6199042M3

1

Jan-06

Quick Attach, Digger
Accouplement Rapide
Acoplamiento rápido

Centremount
Montage de Pelle
Excavadora de montaje central

Telescopic Dipper - Boom 4.5m
 Balancier Téléscopique - Flèche 4.5m
 Balancín telescópico - Pluma 4.5m

Miller
 Miller
 Miller

C-90007-01.1-A

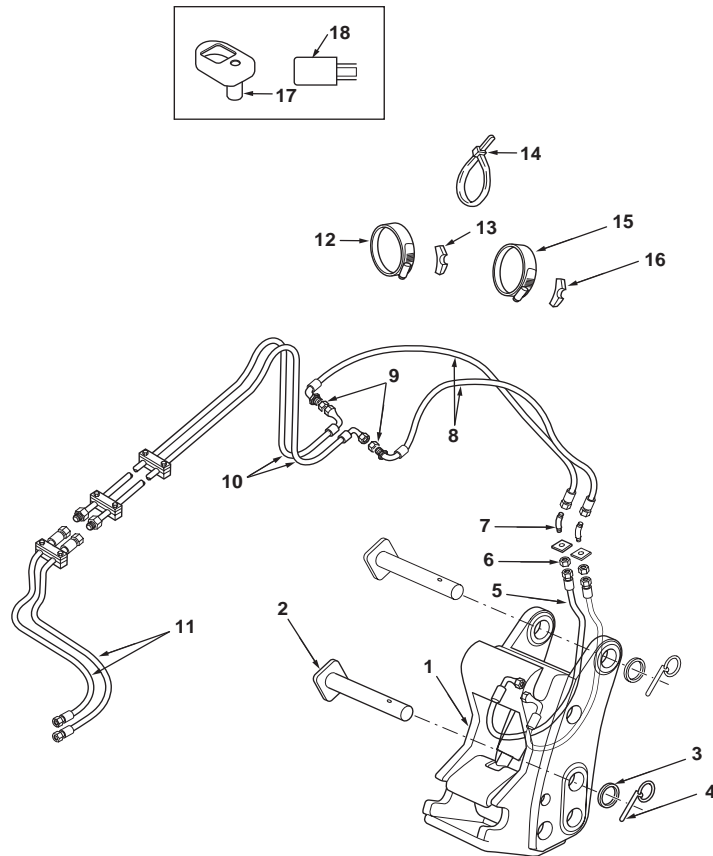

1	6108811M92	90007C04.1 1	1	Hitch Assy, Quick	Ensem. D'attel. Rapide	Engan. rápido, Conj.
2	3516519M94	45 x 302 mm	2	Pin	Axe	Pasador
3	3501790M1		2	Washer	Rondelle	Arandela
4	3516522M91		2	Pin, Linch	Goupille d'arrêt	Pasador de parada
5	6102923M91		2	Hose Assy	Ensemble de flexible	Flexible, Conj.
6	356612X1	7/16" UNF	2	Nut	Écrou	Tuerca
7	371089X1		2	Elbow, 45°	Coude à 45°	Codo, 45°
8	6102922M91		2	Hose Assy	Ensemble de flexible	Flexible, Conj.
9	356612X1	7/16" UNF	2	Nut	Écrou	Tuerca
10	3521945M95		2	Hose Assy	Ensemble de flexible	Flexible, Conj.
11		90007C02.1 11	2	Hose Assy	Ensemble de flexible	Flexible, Conj.
12	3517732M1		1	Clip, Mounting	Collier de fixation	Argolla de fijación
13	D142787		1	Mount, Rubber	Support caoutchouc	Bloque de caucho
14	1664405M1		6	Tie, Cable	Attache câble	Enlace de Cable
15	3517731M1		1	Clip, Mounting	Collier de fixation	Argolla de fijación
16	D142787		1	Mount, Rubber	Support caoutchouc	Bloque de caucho
17	6101777M91	Switch	1	Cover	Cache	Tapa
18	6102490M1		1	Relay	Relais	Relé



820 860 880 970
 TX760B TX860B

801 802 803 804 813 814 821 822 831 832 841 842 851 852 922

90007C01.1

6199042M3

1

Jan-06

Quick Attach, Digger
Accouplement Rapide
Acoplamiento rápido

Centremount
Montage de Pelle
Excavadora de montaje central

Telescopic Dipper - Boom 4.5m
 Balancier Télescopique - Flèche 4.5m
 Balancín telescópico - Pluma 4.5m

Miller
 Miller
 Miller

C-90007-02.1-A

1	365830X91			1	Union	Union	Unión
2		1	➔ Ref. 1	1	Union	Union	Unión
3		1		1	O-Ring	Joint torique	Junta de tipo O
4	6109910M91		Q/A Feed	1	Hose Assy	Ensemble de flexible	Flexible, Conj.
5	6106011M91		98007C03.1	1	Valve, Solenoid	Électrovalve	Electroválvula
6	391244X1		M6 x 45	2	Bolt	Boulon	Perno
7	1441500X1		M6	2	Nut, Lock	Écrou de blocage	Tuerca de retención
8	370807X91			2	Elbow, 90°	Coude à 90°	Codo, 90°
9		8	➔ Ref. 8	1	Elbow	Coude	Codo
10	831452M1			1	O-Ring	Joint torique	Junta de tipo O
11	3519882M92			2	Hose Assy	Ensemble de flexible	Flexible, Conj.
12	365065X91			2	Union	Union	Unión
13		12	➔ Ref. 12	1	Union	Union	Unión
14	831452M1			1	O-Ring	Joint torique	Junta de tipo O
15	3519226M91		Q/A Return	1	Hose Assy	Ensemble de flexible	Flexible, Conj.

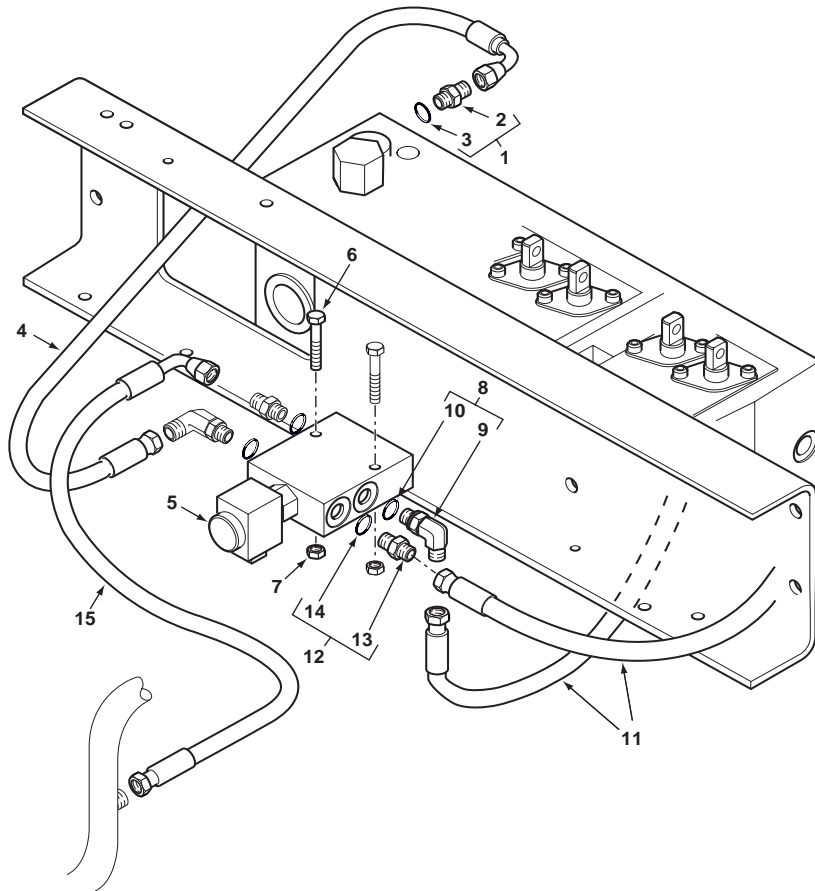

820 860 880 970
 TX760B TX860B

801 802 803 804 813 814 821 822 831 832 841 842 851 852 922

90007C02.1

6199042M3

1

Jan-06

Quick Attach, Digger
Accouplement Rapide
Acoplamiento rápido

Centremount
Montage de Pelle
Excavadora de montaje central

Solenoid Valve
 Electrovanne
 Electroválvula

C-90007-03.1-A

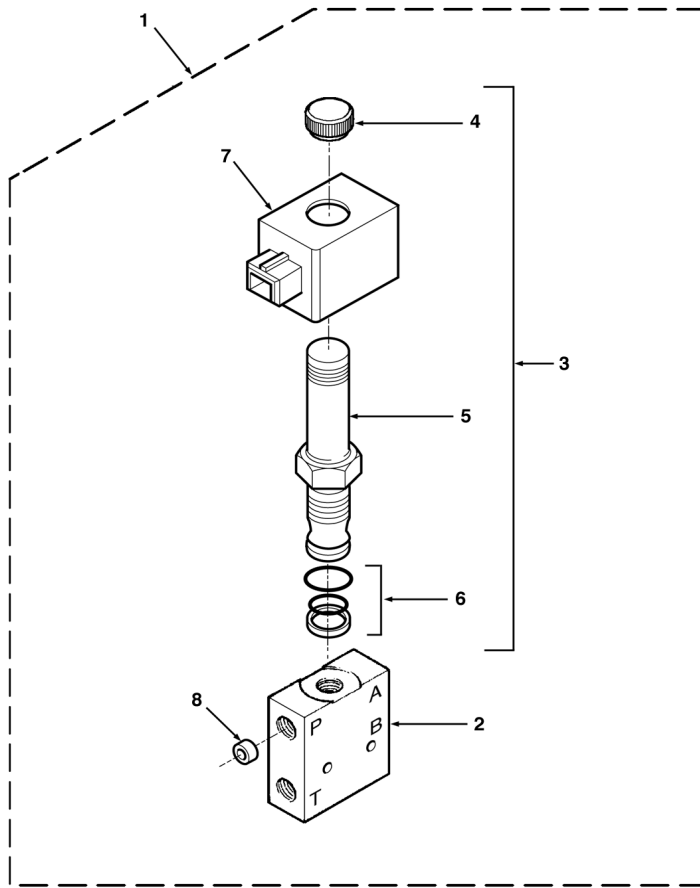

1	6106011M91		90007C02.1 5	1	Valve, Solenoid	Électrovalve	Electroválvula
2		1	Ref. 1	1	Body	Corps	Cuerpo
3	6193020M91	1		1	Solenoid Assy	Ensemble de solénoïde	Solenoïde, Conj.
4		3	Ref. 3	1	Nut	Écrou	Tuerca
5		3	Ref. 3	1	Cartridge	Cartouche	Cartucho
6	6193022M91	3		1	Kit, Seal	Pochette de joints	Juego de juntas
7	6191096M91	1	12V	1	Coil	Bobine	Bobina
8	6193021M1	1		1	Restrictor	Réduction	Reducción



820 860 880 970
 TX760B TX860B

801 802 803 804 813 814 821 822 831 832 841 842 851 852 922

90007C03.1

6199042M3

1

Jan-06

Quick Attach, Digger
Accouplement Rapide
Acoplamiento rápido

Centremount
Montage de Pelle
Excavadora de montaje central

Quick Coupler
Attache Rapide
Acoplamiento rápido

Miller
 Miller
 Miller

C-90007-04.1-A

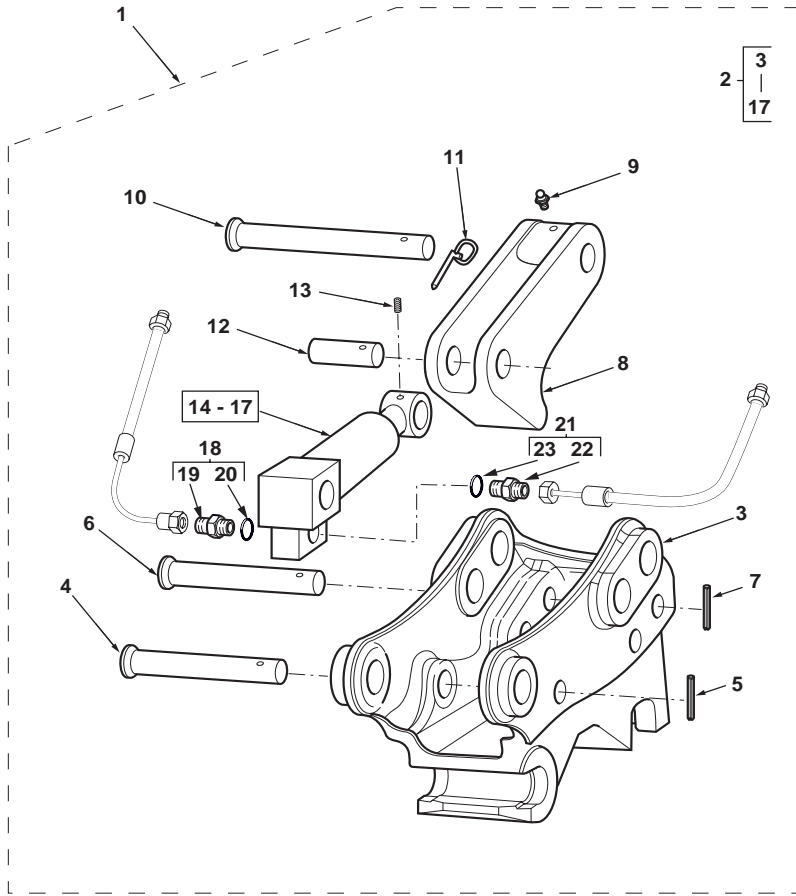

1	6108811M92			1	Hitch Assy, Quick	Ensem. D'attel. Rapide	Engan. rápido, Conj.
2	6102976M91	1		1	Hitch Assy, Quick	Ensem. D'attel. Rapide	Engan. rápido, Conj.
3	6193009M1	2		1	Body	Corps	Cuerpo
4	6193013M1	2	25 x 240 mm	1	Pin	Axe	Pasador
5	6193016M1	2		1	Pin, Roll	Goupille élastique	Pasador elástico
6	6193012M1	2	32 x 240 mm	1	Pin	Axe	Pasador
7	6193016M1	2		1	Pin, Roll	Goupille élastique	Pasador elástico
8	6193010M1	2		1	Hook	Crochet	Gancho
9	6193018M1	2		1	Fitting, Grease	Graisneur	Engrasador
10	6193015M1	2	32 x 240 mm	1	Pin	Axe	Pasador
11	6193017M1	2		1	Pin, Linch	Goupille d'arrêt	Pasador de parada
12	6193014M1	2	25 x 100 mm	1	Pin	Axe	Pasador
13	6193019M1	2		1	Screw	Vis	Tornillo
14	6193011M91	2		1	Cylinder Assy	Ensemble de vérin	Gato, Conj.
15	6193577M91	4	(A)	1	Valve, Check	Clapet anti-retour	Válvula de parada
16	6193578M91	4	(A)	1	Check Valve	Pochette de joints	Juego de juntas
17	6193576M91	4	(A)	1	Q/A Hyd. Cyl.	Pochette de joints	Juego de juntas
18	358741X91	1		1	Union	Union	Unión
19		18	➡ Ref. 18	1	Union	Union	Unión
20	831495M1	18		1	O-Ring	Joint torique	Junta de tipo O
21	6106088M91	1		1	Union	Union	Unión
22		21	➡ Ref. 21	1	Union	Union	Unión
23		21		1	O-Ring	Joint torique	Junta de tipo O

A Not illustrated
 Non illustrée
 No ilustrado



820 860 880 970
 TX760B TX860B

801 802 803 804 813 814 821 822 831 832 841 842 851 852 922

90007C04.1

6199042M3

1

Jan-06

Quick Attach, Digger
Accouplement Rapide
Acoplamiento rápido

Centremount
Montage de Pelle
Excavadora de montaje central

Telescopic Dipper - Boom 4.9m
 Balancier Télescopique - Flèche 4.9m
 Balancín telescópico - Pluma 4.9m

Miller
 Miller
 Miller

C-90008-01.1-A

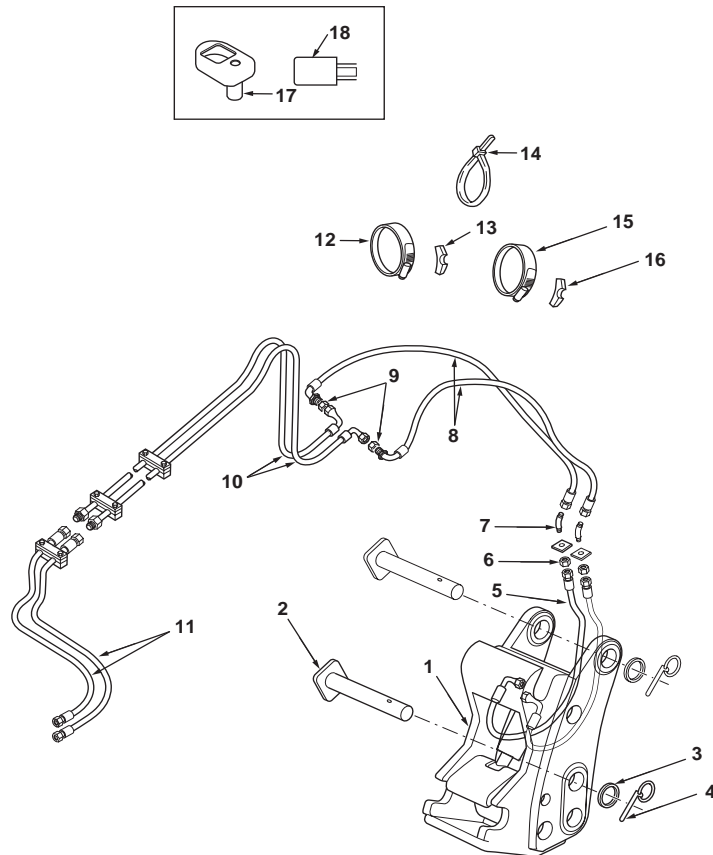

1	6108811M92	90008C04.1 1	1	Hitch Assy, Quick	Ensem. D'attel. Rapide	Engan. rápido, Conj.
2	3516519M94	45 x 302 mm	2	Pin	Axe	Pasador
3	3501790M1		2	Washer	Rondelle	Arandela
4	3516522M91		2	Pin, Linch	Goupille d'arrêt	Pasador de parada
5	6102923M91		2	Hose Assy	Ensemble de flexible	Flexible, Conj.
6	356612X1	7/16" UNF	2	Nut	Écrou	Tuerca
7	371089X1		2	Elbow, 45°	Coude à 45°	Codo, 45°
8	6102922M91		2	Hose Assy	Ensemble de flexible	Flexible, Conj.
9	356612X1	7/16" UNF	2	Nut	Écrou	Tuerca
10	3518145M91		2	Hose Assy	Ensemble de flexible	Flexible, Conj.
11		90008C02.1 11	2	Hose Assy	Ensemble de flexible	Flexible, Conj.
12	3517732M1		1	Clip, Mounting	Collier de fixation	Argolla de fijación
13	D142787		1	Mount, Rubber	Support caoutchouc	Bloque de caucho
14	1664405M1		6	Tie, Cable	Attache câble	Enlace de Cable
15	3517731M1		1	Clip, Mounting	Collier de fixation	Argolla de fijación
16	D142787		1	Mount, Rubber	Support caoutchouc	Bloque de caucho
17	6101777M91	Switch	1	Cover	Cache	Tapa
18	6102490M1		1	Relay	Relais	Relé



860 880 970 980
 TX870B TX970B

815 816 823 824 843 844 853 854 923 932

90008C01.1

6199042M3

1

Jan-06

Quick Attach, Digger
Accouplement Rapide
Acoplamiento rápido

Centremount
Montage de Pelle
Excavadora de montaje central

Telescopic Dipper - Boom 4.9m
 Balancier Télescopique - Flèche 4.9m
 Balancín telescópico - Pluma 4.9m

Miller
 Miller
 Miller

C-90008-02.1-A

1	365830X91			1	Union	Union	Unión
2		1	Ref. 1	1	Union	Union	Unión
3		1		1	O-Ring	Joint torique	Junta de tipo O
4	6109910M91		Q/A Feed	1	Hose Assy	Ensemble de flexible	Flexible, Conj.
5	6106011M91		98008C03.1	1	Valve, Solenoid	Électrovalve	Electroválvula
6	391244X1		M6 x 45	2	Bolt	Boulon	Perno
7	1441500X1		M6	2	Nut, Lock	Écrou de blocage	Tuerca de retención
8	370807X91			2	Elbow, 90°	Coude à 90°	Codo, 90°
9		8	Ref. 8	1	Elbow	Coude	Codo
10	831452M1			1	O-Ring	Joint torique	Junta de tipo O
11	3519882M92			2	Hose Assy	Ensemble de flexible	Flexible, Conj.
12	365065X91			2	Union	Union	Unión
13		12	Ref. 12	1	Union	Union	Unión
14	831452M1			1	O-Ring	Joint torique	Junta de tipo O
15	3519226M91		Q/A Return	1	Hose Assy	Ensemble de flexible	Flexible, Conj.

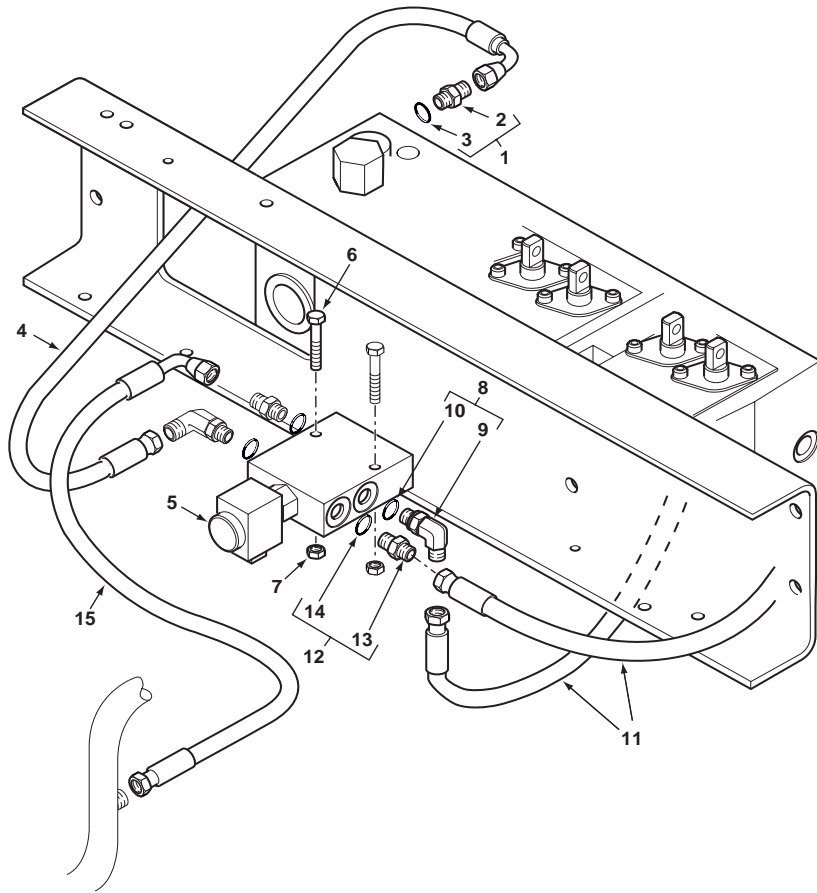

860 880 970 980
 TX870B TX970B

815 816 823 824 843 844 853 854 923 932

90008C02.1

6199042M3

1

Jan-06

Quick Attach, Digger
Accouplement Rapide
Acoplamiento rápido

Centremount
Montage de Pelle
Excavadora de montaje central

Solenoid Valve
Électrovanne
Electroválvula

C-90008-03.1-A

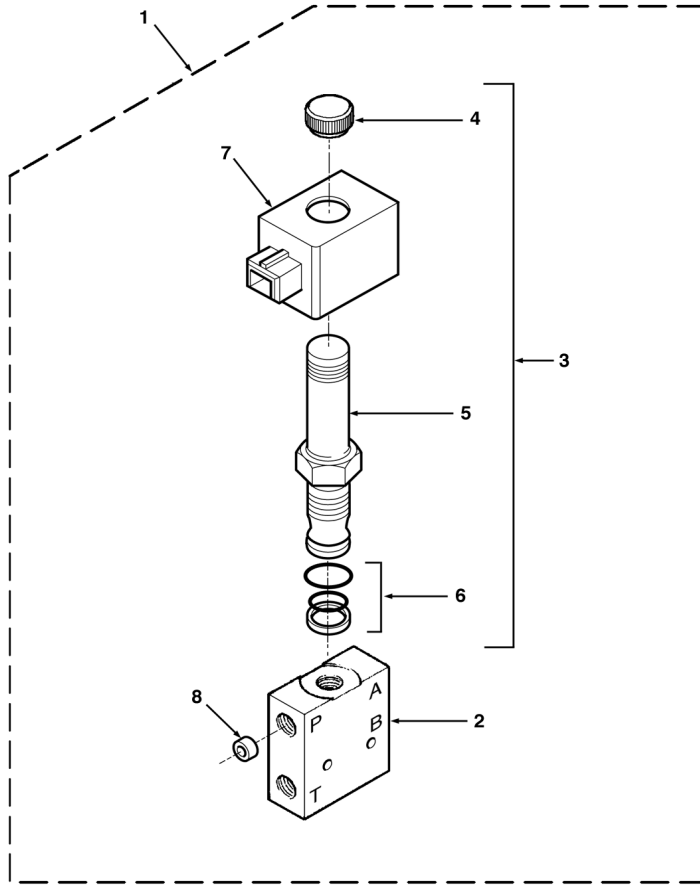

1	6106011M91		90008C02.1 5	1	Valve, Solenoid	Électrovalve	Electroválvula
2		1	Ref. 1	1	Body	Corps	Cuerpo
3	6193020M91	1		1	Solenoid Assy	Ensemble de solénoïde	Solenoïde, Conj.
4		3	Ref. 3	1	Nut	Écrou	Tuerca
5		3	Ref. 3	1	Cartridge	Cartouche	Cartucho
6	6193022M91	3		1	Kit, Seal	Pochette de joints	Juego de juntas
7	6191096M91	1	12V	1	Coil	Bobine	Bobina
8	6193021M1	1		1	Restrictor	Réduction	Reducción



860 880 970 980
TX870B TX970B

815 816 823 824 843 844 853 854 923 932

90008C03.1

6199042M3

1

Jan-06

Quick Attach, Digger
Accouplement Rapide
Acoplamiento rápido

Centremount
Montage de Pelle
Excavadora de montaje central

Quick Coupler
Attache Rapide
Acoplamiento rápido

Miller
 Miller
 Miller

C-90008-04.1-A

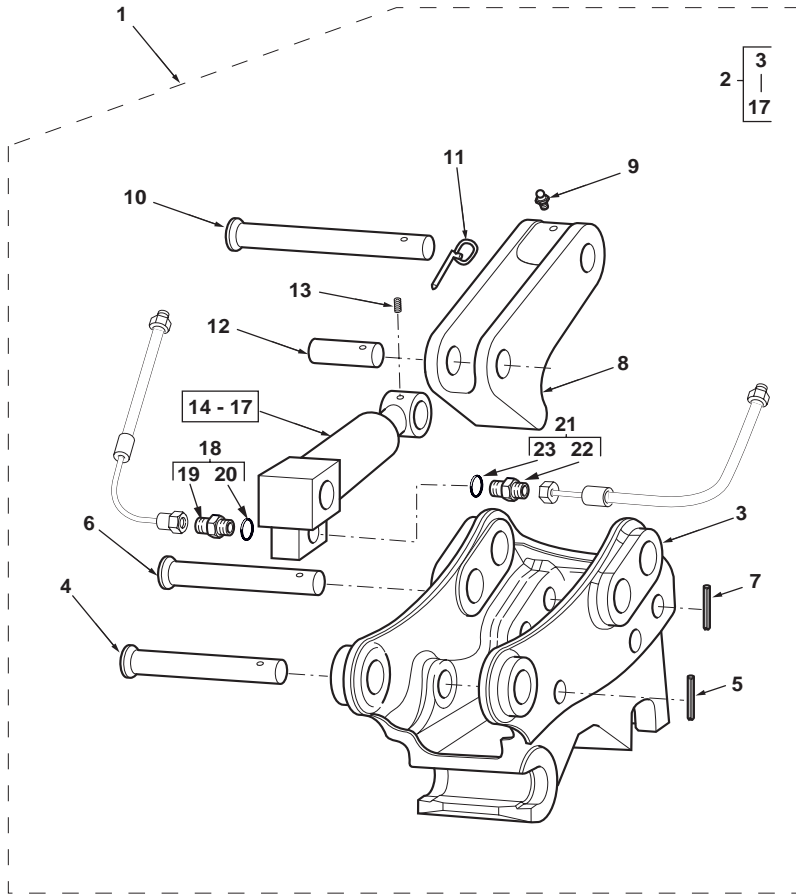

1	6108811M92			1	Hitch Assy, Quick	Ensem. D'attel. Rapide	Engan. rápido, Conj.
2	6102976M91	1		1	Hitch Assy, Quick	Ensem. D'attel. Rapide	Engan. rápido, Conj.
3	6193009M1	2		1	Body	Corps	Cuerpo
4	6193013M1	2	25 x 240 mm	1	Pin	Axe	Pasador
5	6193016M1	2		1	Pin, Roll	Goupille élastique	Pasador elástico
6	6193012M1	2	32 x 240 mm	1	Pin	Axe	Pasador
7	6193016M1	2		1	Pin, Roll	Goupille élastique	Pasador elástico
8	6193010M1	2		1	Hook	Crochet	Gancho
9	6193018M1	2		1	Fitting, Grease	Graisneur	Engrasador
10	6193015M1	2	32 x 240 mm	1	Pin	Axe	Pasador
11	6193017M1	2		1	Pin, Linch	Goupille d'arrêt	Pasador de parada
12	6193014M1	2	25 x 100 mm	1	Pin	Axe	Pasador
13	6193019M1	2		1	Screw	Vis	Tornillo
14	6193011M91	2		1	Cylinder Assy	Ensemble de vérin	Gato, Conj.
15	6193577M91	4	(A)	1	Valve, Check	Clapet anti-retour	Válvula de parada
16	6193578M91	4	(A)	1	Check Valve	Pochette de joints	Juego de juntas
17	6193576M91	4	(A)	1	Q/A Hyd. Cyl.	Pochette de joints	Juego de juntas
18	358741X91	1		1	Union	Union	Unión
19		18	➡ Ref. 18	1	Union	Union	Unión
20	831495M1	18		1	O-Ring	Joint torique	Junta de tipo O
21	6106088M91	1		1	Union	Union	Unión
22		21	➡ Ref. 21	1	Union	Union	Unión
23		21		1	O-Ring	Joint torique	Junta de tipo O

A Not illustrated
 Non illustrée
 No ilustrado



860 880 970 980
 TX870B TX970B

815 816 823 824 843 844 853 854 923 932

90008C04.1

6199042M3

1

Jan-06

Quick Attach, Digger
Accouplement Rapide
Acoplamiento rápido

Centremount
Montage de Pelle
Excavadora de montaje central

Standard Dipper
Balancier Standard
Balancín estándar

Less Q/A
 Less Q/A
 Less Q/A

C-90013-01.1-A

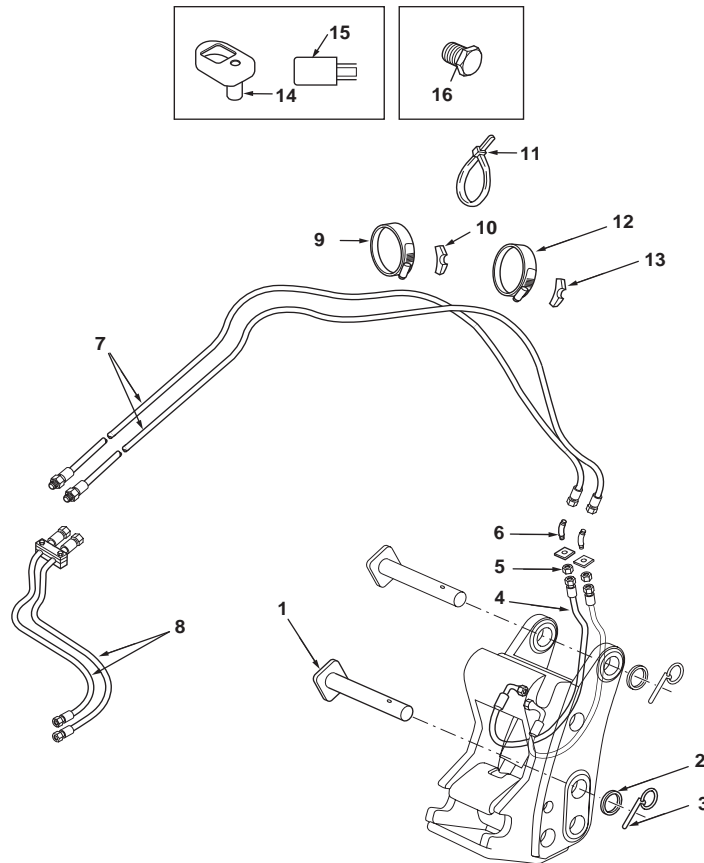

1	3516519M94	45 x 302 mm	2	Pin	Axe	Pasador
2	3501790M1		2	Washer	Rondelle	Arandela
3	3516522M91		2	Pin, Linch	Goupille d'arrêt	Pasador de parada
4	6102923M91		2	Hose Assy	Ensemble de flexible	Flexible, Conj.
5	356612X1	7/16" UNF	2	Nut	Écrou	Tuerca
6	371089X1		2	Elbow, 45°	Coude à 45°	Codo, 45°
7	6106086M91		2	Hose Assy	Ensemble de flexible	Flexible, Conj.
8		90013C02.1 11	2	Hose Assy	Ensemble de flexible	Flexible, Conj.
9	3517732M1		1	Clip, Mounting	Collier de fixation	Argolla de fijación
10	D142787		1	Mount, Rubber	Support caoutchouc	Bloque de caucho
11	1664405M1		6	Tie, Cable	Attache câble	Enlace de Cable
12	3517731M1		1	Clip, Mounting	Collier de fixation	Argolla de fijación
13	D142787		1	Mount, Rubber	Support caoutchouc	Bloque de caucho
14	6101777M91	Switch	1	Cover	Cache	Tapa
15	6102490M1		1	Relay	Relais	Relé
16	218-772		2	Plug	Bouchon	Tapón



880
 TX760B TX860B

831 832 841 842 851 852

90013C01.1

6199042M3

1

Jan-06

Quick Attach, Digger
Accouplement Rapide
Acoplamiento rápido

Centremount
Montage de Pelle
Excavadora de montaje central

Standard Dipper
Balancier Standard
Balancín estándar

Less Q/A
Less Q/A
Less Q/A

C-90013-02.1-A

1	365830X91		1	Union	Union	Unión
2		1  Ref. 1	1	Union	Union	Unión
3		1	1	O-Ring	Joint torique	Junta de tipo O
4	6109910M91	Q/A Feed	1	Hose Assy	Ensemble de flexible	Flexible, Conj.
5	6106011M91	 90013C03.1	1	Valve, Solenoid	Électrovalve	Electroválvula
6	391244X1	M6 x 45	2	Bolt	Boulon	Perno
7	1441500X1	M6	2	Nut, Lock	Écrou de blocage	Tuerca de retención
8	370807X91		2	Elbow, 90°	Coude à 90°	Codo, 90°
9		8  Ref. 8	1	Elbow	Coude	Codo
10	831452M1	8	1	O-Ring	Joint torique	Junta de tipo O
11	6102806M91		2	Hose Assy	Ensemble de flexible	Flexible, Conj.
12	365065X91		2	Union	Union	Unión
13		12  Ref. 12	1	Union	Union	Unión
14	831452M1	12	1	O-Ring	Joint torique	Junta de tipo O
15	3519226M91	Q/A Return	1	Hose Assy	Ensemble de flexible	Flexible, Conj.

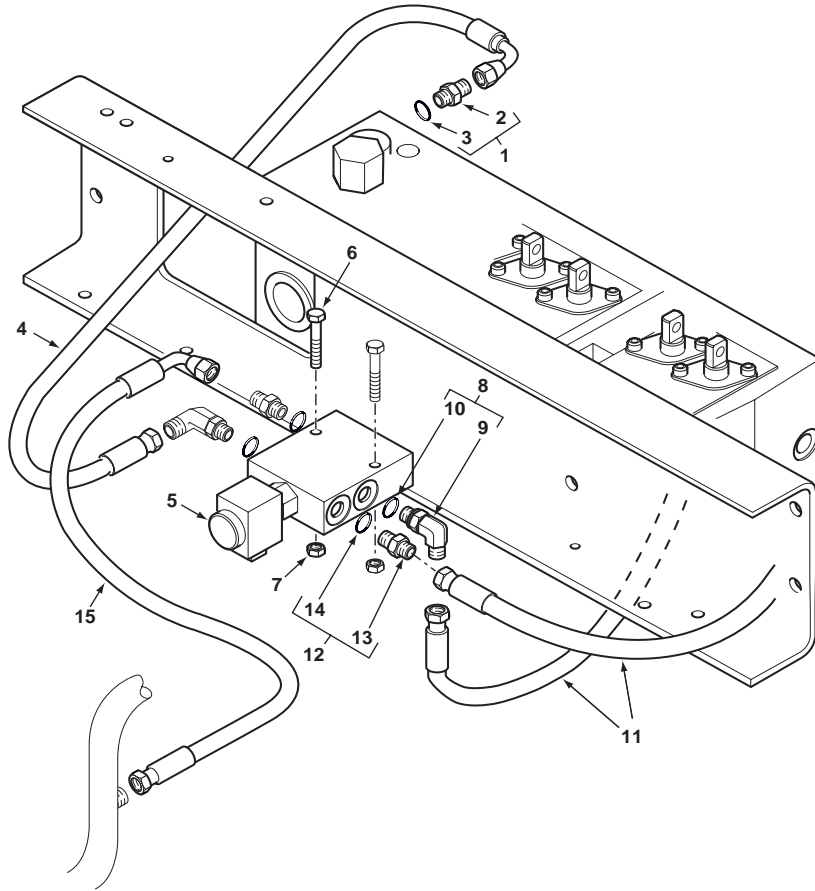

880
TX760B TX860B

831 832 841 842 851 852

90013C02.1

6199042M3

1

Jan-06

Quick Attach, Digger
Accouplement Rapide
Acoplamiento rápido

Centremount
Montage de Pelle
Excavadora de montaje central

Solenoid Valve
Électrovanne
Electroválvula

C-90013-03.1-A

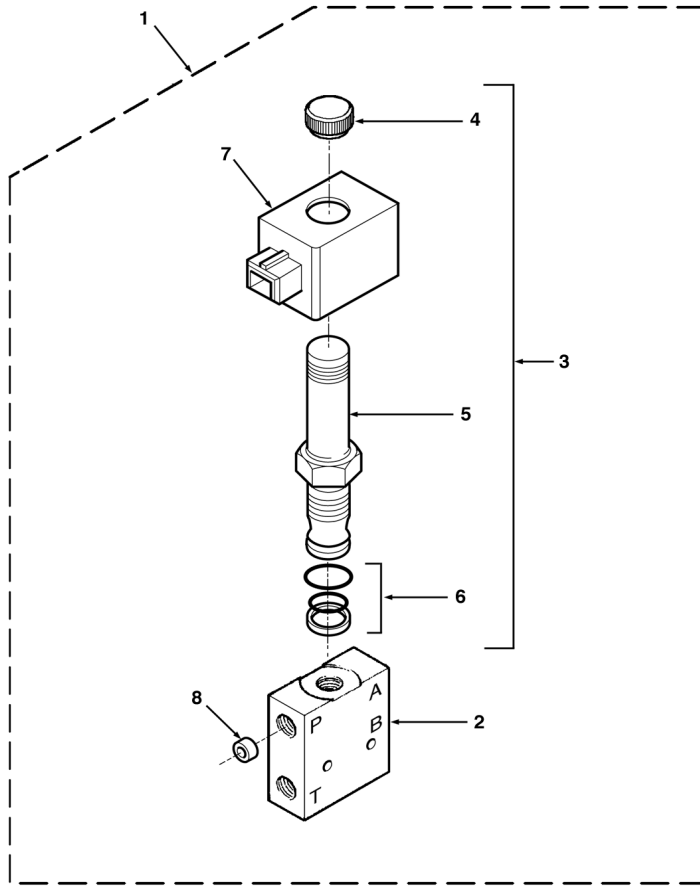

1	6106011M91		90013C02.1 5	1	Valve, Solenoid	Électrovalve	Electroválvula
2		1	Ref. 1	1	Body	Corps	Cuerpo
3	6193020M91	1		1	Solenoid Assy	Ensemble de solénoïde	Solenoïde, Conj.
4		3	Ref. 3	1	Nut	Écrou	Tuerca
5		3	Ref. 3	1	Cartridge	Cartouche	Cartucho
6	6193022M91	3		1	Kit, Seal	Pochette de joints	Juego de juntas
7	6191096M91	1	12V	1	Coil	Bobine	Bobina
8	6193021M1	1		1	Restrictor	Réduction	Reducción



880
 TX760B TX860B

831 832 841 842 851 852

90013C03.1

6199042M3

1

Jan-06

Quick Attach, Digger
Accouplement Rapide
Acoplamiento rápido

Centremount
Montage de Pelle
Excavadora de montaje central

Standard Dipper
Balancier Standard
Balancín estándar

Less Q/A
Less Q/A
Less Q/A

C-90014-01.1-A

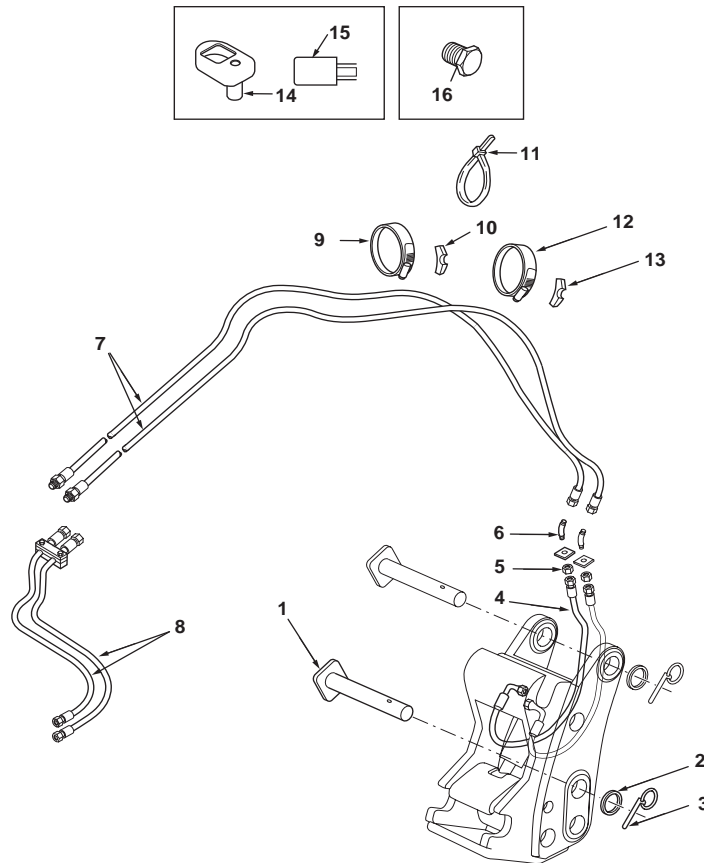

1	3516519M94	45 x 302 mm	2	Pin	Axe	Pasador
2	3501790M1		2	Washer	Rondelle	Arandela
3	3516522M91		2	Pin, Linch	Goupille d'arrêt	Pasador de parada
4	6102923M91		2	Hose Assy	Ensemble de flexible	Flexible, Conj.
5	356612X1	7/16" UNF	2	Nut	Écrou	Tuerca
6	371089X1		2	Elbow, 45°	Coude à 45°	Codo, 45°
7	6106087M91		2	Hose Assy	Ensemble de flexible	Flexible, Conj.
8		90014C02.1 11	2	Hose Assy	Ensemble de flexible	Flexible, Conj.
9	3517732M1		1	Clip, Mounting	Collier de fixation	Argolla de fijación
10	D142787		1	Mount, Rubber	Support caoutchouc	Bloque de caучо
11	1664405M1		6	Tie, Cable	Attache câble	Enlace de Cable
12	3517731M1		1	Clip, Mounting	Collier de fixation	Argolla de fijación
13	D142787		1	Mount, Rubber	Support caoutchouc	Bloque de caучо
14	6101777M91	Switch	1	Cover	Cache	Tapa
15	6102490M1		1	Relay	Relais	Relé
16	218-772		2	Plug	Bouchon	Tapón



880 980
TX870B TX970B

843 844 853 854 932

90014C01.1

6199042M3

1

Jan-06

Quick Attach, Digger
Accouplement Rapide
Acoplamiento rápido

Centremount
Montage de Pelle
Excavadora de montaje central

Standard Dipper
Balancier Standard
Balancín estándar

Less Q/A
Less Q/A
Less Q/A

C-90014-02.1-A

1	365830X91		1	Union	Union	Unión
2		1  Ref. 1	1	Union	Union	Unión
3		1	1	O-Ring	Joint torique	Junta de tipo O
4	6109910M91	Q/A Feed	1	Hose Assy	Ensemble de flexible	Flexible, Conj.
5	6106011M91	 90014C03.1	1	Valve, Solenoid	Électrovalve	Electroválvula
6	391244X1	M6 x 45	2	Bolt	Boulon	Perno
7	1441500X1	M6	2	Nut, Lock	Écrou de blocage	Tuerca de retención
8	370807X91		2	Elbow, 90°	Coude à 90°	Codo, 90°
9		8  Ref. 8	1	Elbow	Coude	Codo
10	831452M1	8	1	O-Ring	Joint torique	Junta de tipo O
11	6102806M91		2	Hose Assy	Ensemble de flexible	Flexible, Conj.
12	365065X91		2	Union	Union	Unión
13		12  Ref. 12	1	Union	Union	Unión
14	831452M1	12	1	O-Ring	Joint torique	Junta de tipo O
15	3519226M91	Q/A Return	1	Hose Assy	Ensemble de flexible	Flexible, Conj.

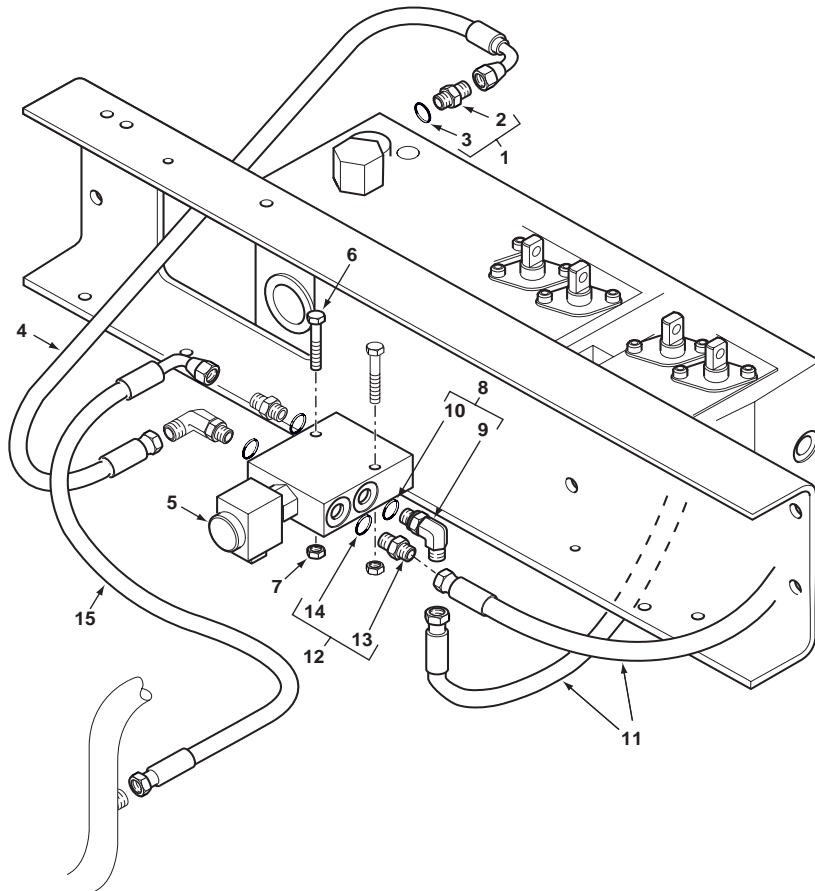

880 980
TX870B TX970B

843 844 853 854 932

90014C02.1

6199042M3

1

Jan-06

Quick Attach, Digger
Accouplement Rapide
Acoplamiento rápido

Centremount
Montage de Pelle
Excavadora de montaje central

Solenoid Valve
Électrovanne
Electroválvula

C-90014-03.1-A

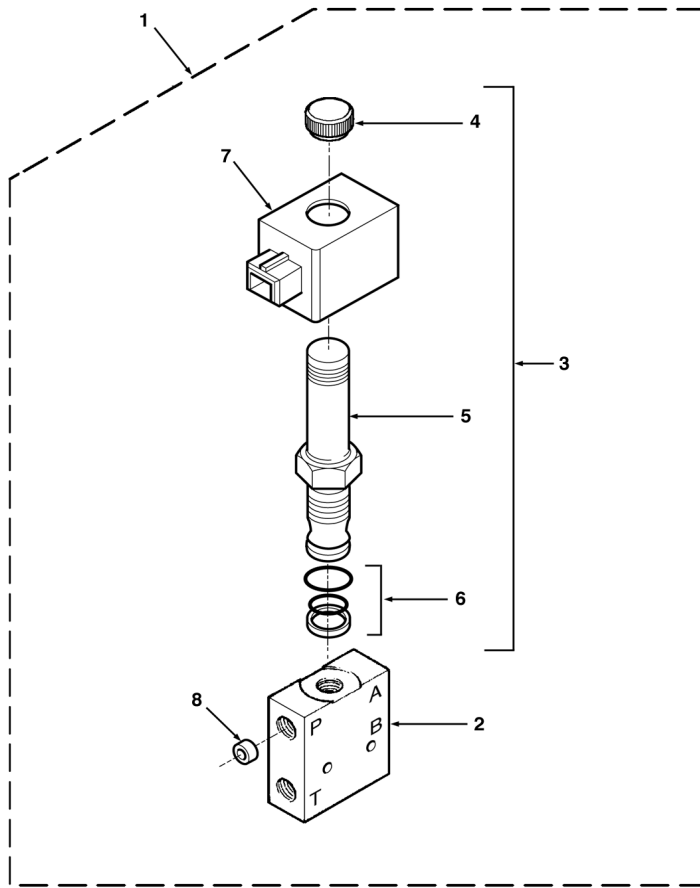

1	6106011M91		90014C02.1 5	1	Valve, Solenoid	Électrovalve	Electroválvula
2		1	Ref. 1	1	Body	Corps	Cuerpo
3	6193020M91	1		1	Solenoid Assy	Ensemble de solénoïde	Solenoïde, Conj.
4		3	Ref. 3	1	Nut	Écrou	Tuerca
5		3	Ref. 3	1	Cartridge	Cartouche	Cartucho
6	6193022M91	3		1	Kit, Seal	Pochette de joints	Juego de juntas
7	6191096M91	1	12V	1	Coil	Bobine	Bobina
8	6193021M1	1		1	Restrictor	Réduction	Reducción



880 980
 TX870B TX970B

843 844 853 854 932

90014C03.1

6199042M3

1

Jan-06

Quick Attach, Digger
Accouplement Rapide
Acoplamiento rápido

Centremount
Montage de Pelle
Excavadora de montaje central

Telescopic Dipper
Balancier Téléscopique
Balancín telescópico

Less Q/A
Less Q/A
Less Q/A

C-90015-01.1-A

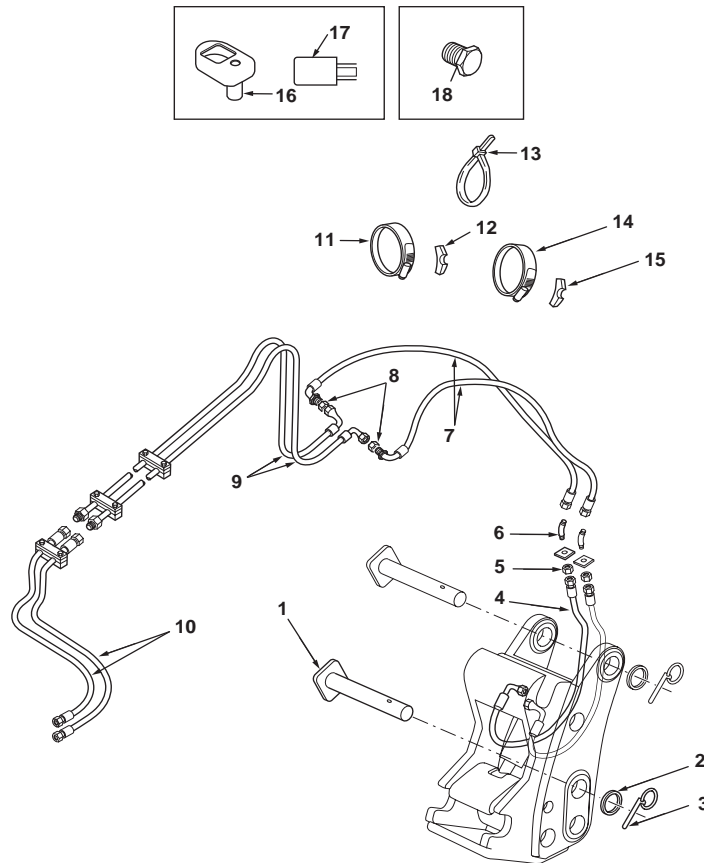

1	3516519M94	45 x 302 mm	2	Pin	Axe	Pasador
2	3501790M1		2	Washer	Rondelle	Arandela
3	3516522M91		2	Pin, Linch	Goupille d'arrêt	Pasador de parada
4	6102923M91		2	Hose Assy	Ensemble de flexible	Flexible, Conj.
5	356612X1	7/16" UNF	2	Nut	Écrou	Tuerca
6	371089X1		2	Elbow, 45°	Coude à 45°	Codo, 45°
7	6102922M91		2	Hose Assy	Ensemble de flexible	Flexible, Conj.
8	356612X1	7/16" UNF	2	Nut	Écrou	Tuerca
9	3521945M95		2	Hose Assy	Ensemble de flexible	Flexible, Conj.
10		90015C02.1 11	2	Hose Assy	Ensemble de flexible	Flexible, Conj.
11	3517732M1		1	Clip, Mounting	Collier de fixation	Argolla de fijación
12	D142787		1	Mount, Rubber	Support caoutchouc	Bloque de caoucho
13	1664405M1		6	Tie, Cable	Attache câble	Enlace de Cable
14	3517731M1		1	Clip, Mounting	Collier de fixation	Argolla de fijación
15	D142787		1	Mount, Rubber	Support caoutchouc	Bloque de caoucho
16	6101777M91	Switch	1	Cover	Cache	Tapa
17	6102490M1		1	Relay	Relais	Relé
18	218-772		2	Plug	Bouchon	Tapón



880
TX760B TX860B

831 832 841 842 851 852

90015C01.1

6199042M3

1

Jan-06

Quick Attach, Digger
Accouplement Rapide
Acoplamiento rápido

Centremount
Montage de Pelle
Excavadora de montaje central

Telescopic Dipper
Balancier Téléscopique
Balancín telescópico

Less Q/A
Less Q/A
Less Q/A

C-90015-02.1-A

1	365830X91		1	Union	Union	Unión
2		1  Ref. 1	1	Union	Union	Unión
3		1	1	O-Ring	Joint torique	Junta de tipo O
4	6109910M91	Q/A Feed	1	Hose Assy	Ensemble de flexible	Flexible, Conj.
5	6106011M91	 90015C03.1	1	Valve, Solenoid	Électrovalve	Electroválvula
6	391244X1	M6 x 45	2	Bolt	Boulon	Perno
7	1441500X1	M6	2	Nut, Lock	Écrou de blocage	Tuerca de retención
8	370807X91		2	Elbow, 90°	Coude à 90°	Codo, 90°
9		8  Ref. 8	1	Elbow	Coude	Codo
10	831452M1	8	1	O-Ring	Joint torique	Junta de tipo O
11	6102806M91		2	Hose Assy	Ensemble de flexible	Flexible, Conj.
12	365065X91		2	Union	Union	Unión
13		12  Ref. 12	1	Union	Union	Unión
14	831452M1	12	1	O-Ring	Joint torique	Junta de tipo O
15	3519226M91	Q/A Return	1	Hose Assy	Ensemble de flexible	Flexible, Conj.

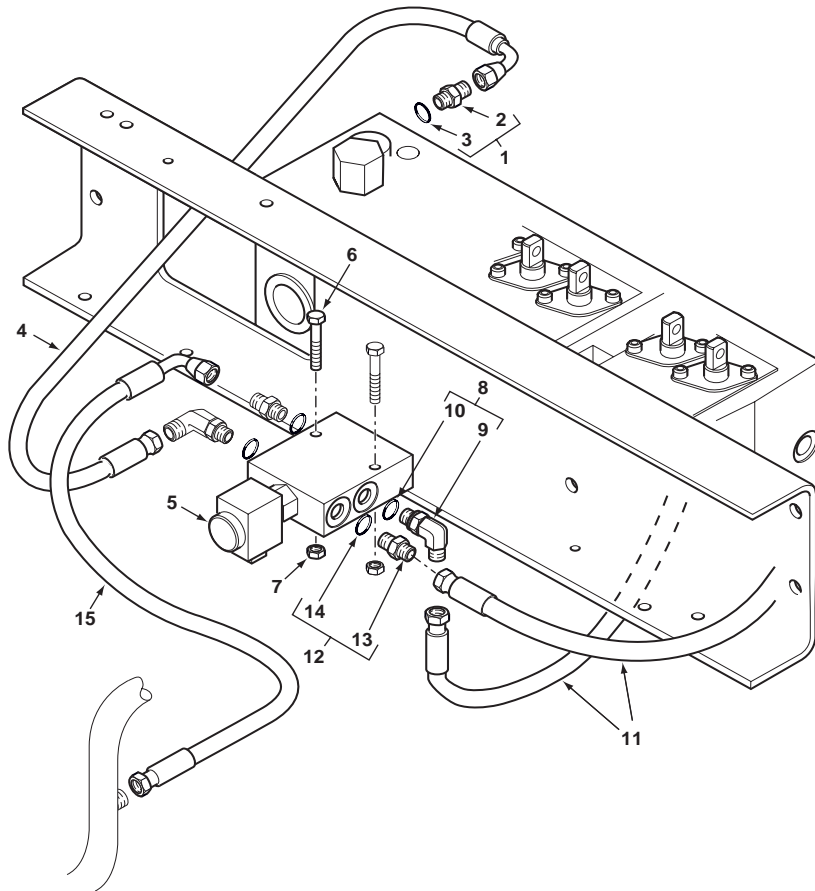

880
TX760B TX860B

831 832 841 842 851 852

90015C02.1

6199042M3

1

Jan-06

Quick Attach, Digger
Accouplement Rapide
Acoplamiento rápido

Centremount
Montage de Pelle
Excavadora de montaje central

Solenoid Valve
Électrovanne
Electroválvula

C-90015-03.1-A

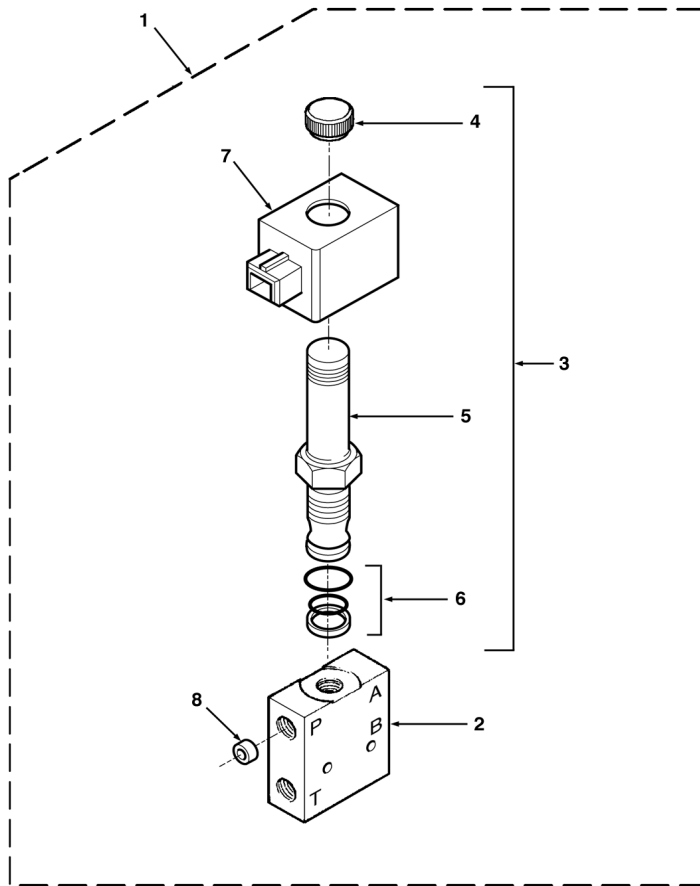

1	6106011M91		90015C02.1 5	1	Valve, Solenoid	Électrovalve	Electroválvula
2		1	Ref. 1	1	Body	Corps	Cuerpo
3	6193020M91	1		1	Solenoid Assy	Ensemble de solénoïde	Solenoïde, Conj.
4		3	Ref. 3	1	Nut	Écrou	Tuerca
5		3	Ref. 3	1	Cartridge	Cartouche	Cartucho
6	6193022M91	3		1	Kit, Seal	Pochette de joints	Juego de juntas
7	6191096M91	1	12V	1	Coil	Bobine	Bobina
8	6193021M1	1		1	Restrictor	Réduction	Reducción



880
TX760B TX860B

831 832 841 842 851 852

90015C03.1

6199042M3

1

Jan-06

Quick Attach, Digger
Accouplement Rapide
Acoplamiento rápido

Centremount
Montage de Pelle
Excavadora de montaje central

Telescopic Dipper
Balancier Téléscopique
Balancín telescópico

Less Q/A
 Less Q/A
 Less Q/A

C-90016-01.1-A

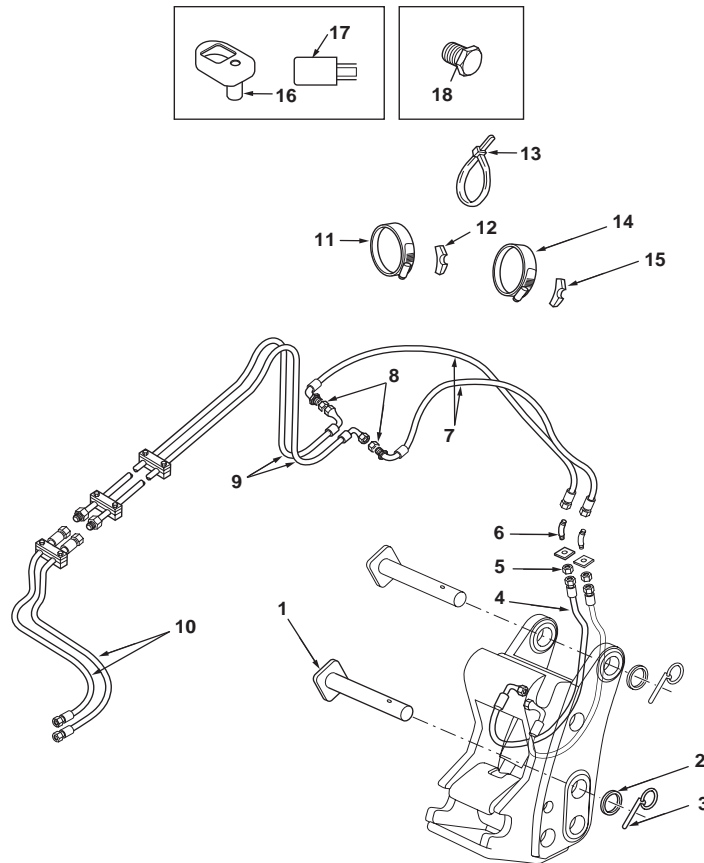

1	3516519M94	45 x 302 mm	2	Pin	Axe	Pasador
2	3501790M1		2	Washer	Rondelle	Arandela
3	3516522M91		2	Pin, Linch	Goupille d'arrêt	Pasador de parada
4	6102923M91		2	Hose Assy	Ensemble de flexible	Flexible, Conj.
5	356612X1	7/16" UNF	2	Nut	Écrou	Tuerca
6	371089X1		2	Elbow, 45°	Coude à 45°	Codo, 45°
7	6102922M91		2	Hose Assy	Ensemble de flexible	Flexible, Conj.
8	356612X1	7/16" UNF	2	Nut	Écrou	Tuerca
9	3518145M91		2	Hose Assy	Ensemble de flexible	Flexible, Conj.
10		90016C02.1 11	2	Hose Assy	Ensemble de flexible	Flexible, Conj.
11	3517732M1		1	Clip, Mounting	Collier de fixation	Argolla de fijación
12	D142787		1	Mount, Rubber	Support caoutchouc	Bloque de caoucho
13	1664405M1		6	Tie, Cable	Attache câble	Enlace de Cable
14	3517731M1		1	Clip, Mounting	Collier de fixation	Argolla de fijación
15	D142787		1	Mount, Rubber	Support caoutchouc	Bloque de caoucho
16	6101777M91	Switch	1	Cover	Cache	Tapa
17	6102490M1		1	Relay	Relais	Relé
18	218-772		2	Plug	Bouchon	Tapón



880 980
 TX870B TX970B

843 844 853 854 932

90016C01.1

6199042M3

1

Jan-06

Quick Attach, Digger
Accouplement Rapide
Acoplamiento rápido

Centremount
Montage de Pelle
Excavadora de montaje central

Telescopic Dipper
Balancier Télescopique
Balancín telescópico

Less Q/A
Less Q/A
Less Q/A

C-90016-02.1-A

1	365830X91		1	Union	Union	Unión
2		1  Ref. 1	1	Union	Union	Unión
3		1	1	O-Ring	Joint torique	Junta de tipo O
4	6109910M91	Q/A Feed	1	Hose Assy	Ensemble de flexible	Flexible, Conj.
5	6106011M91	 90016C03.1	1	Valve, Solenoid	Électrovalve	Electroválvula
6	391244X1	M6 x 45	2	Bolt	Boulon	Perno
7	1441500X1	M6	2	Nut, Lock	Écrou de blocage	Tuerca de retención
8	370807X91		2	Elbow, 90°	Coude à 90°	Codo, 90°
9		8  Ref. 8	1	Elbow	Coude	Codo
10	831452M1	8	1	O-Ring	Joint torique	Junta de tipo O
11	6102806M91		2	Hose Assy	Ensemble de flexible	Flexible, Conj.
12	365065X91		2	Union	Union	Unión
13		12  Ref. 12	1	Union	Union	Unión
14	831452M1	12	1	O-Ring	Joint torique	Junta de tipo O
15	3519226M91	Q/A Return	1	Hose Assy	Ensemble de flexible	Flexible, Conj.

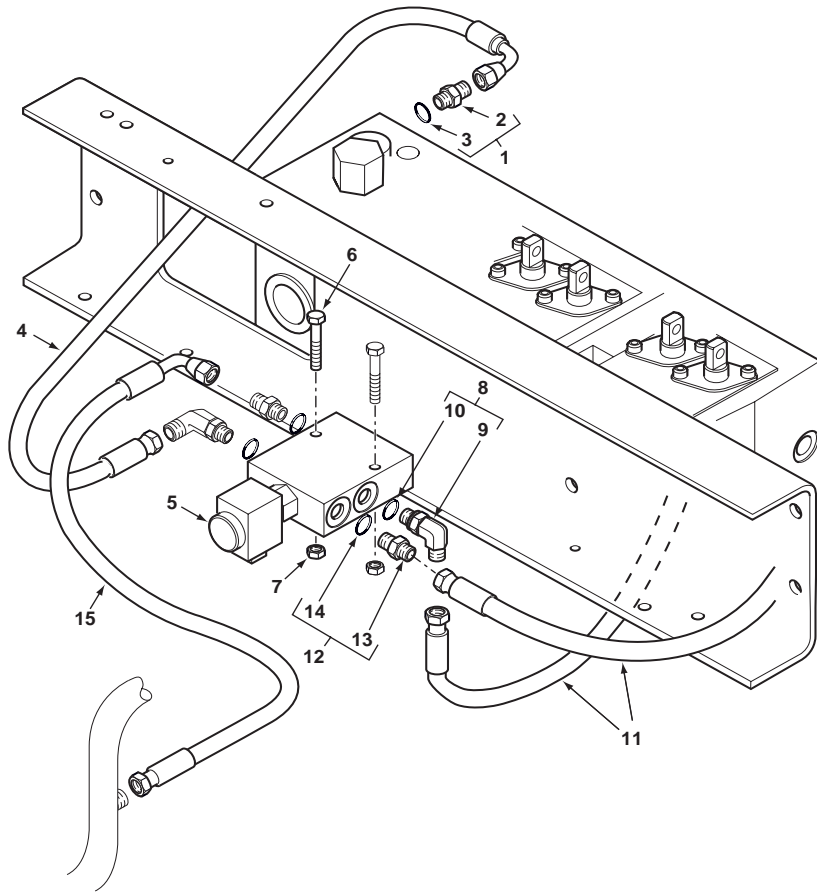

880 980
TX870B TX970B

843 844 853 854 932

90016C02.1

6199042M3

1

Jan-06

Quick Attach, Digger
Accouplement Rapide
Acoplamiento rápido

Centremount
Montage de Pelle
Excavadora de montaje central

Solenoid Valve
Électrovanne
Electroválvula

C-90016-03.1-A

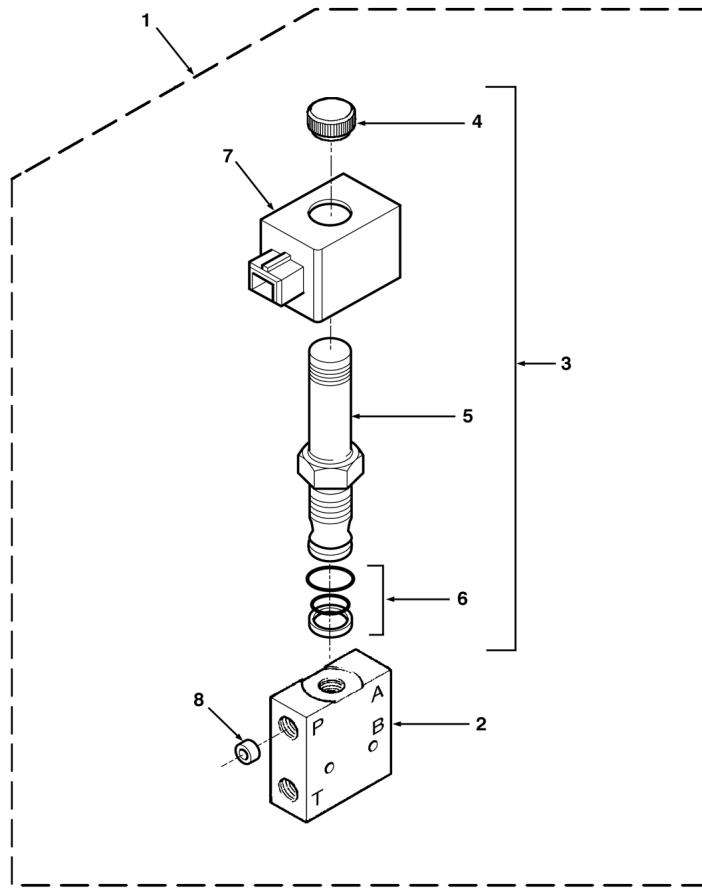

1	6106011M91		90016C02.1 5	1	Valve, Solenoid	Électrovalve	Electroválvula
2		1	Ref. 1	1	Body	Corps	Cuerpo
3	6193020M91	1		1	Solenoid Assy	Ensemble de solénoïde	Solenoïde, Conj.
4		3	Ref. 3	1	Nut	Écrou	Tuerca
5		3	Ref. 3	1	Cartridge	Cartouche	Cartucho
6	6193022M91	3		1	Kit, Seal	Pochette de joints	Juego de juntas
7	6191096M91	1	12V	1	Coil	Bobine	Bobina
8	6193021M1	1		1	Restrictor	Réduction	Reducción



880 980
TX870B TX970B

843 844 853 854 932

90016C03.1

6199042M3

1

Jan-06

Quick Attach, Digger
Accouplement Rapide
Acoplamiento rápido

Sideshift
Montage de Pelle Latéral
Excavadora de montaje horizontal

Standard Dipper
Balancier Standard
Balancín estándar

Miller
 Miller
 Miller

C-90001-01.1-A

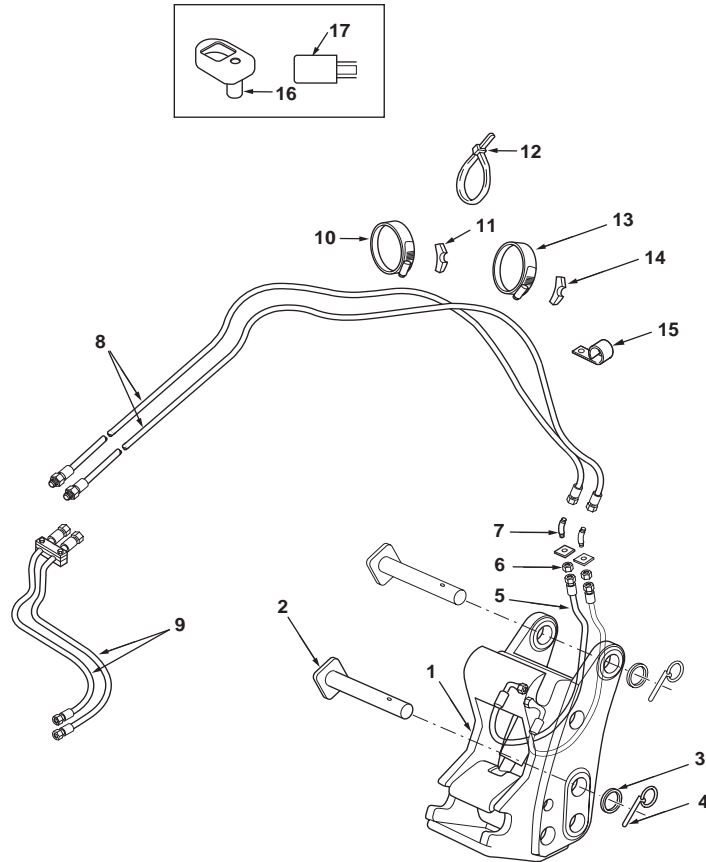

1	6108811M92	90001C04.1 1	1	Hitch Assy, Quick	Ensem. D'attel. Rapide	Engan. rápido, Conj.
2	3516519M94	45 x 302 mm	2	Pin	Axe	Pasador
3	3501790M1		2	Washer	Rondelle	Arandela
4	3516522M91		2	Pin, Linch	Goupille d'arrêt	Pasador de parada
5	6102923M91		2	Hose Assy	Ensemble de flexible	Flexible, Conj.
6	356612X1	7/16" UNF	2	Nut	Écrou	Tuerca
7	371089X1		2	Elbow, 45°	Coude à 45°	Codo, 45°
8	6106086M91		2	Hose Assy	Ensemble de flexible	Flexible, Conj.
9		90001C02.1 11	2	Hose Assy	Ensemble de flexible	Flexible, Conj.
10	3517732M1		1	Clip, Mounting	Collier de fixation	Argolla de fijación
11	D142787		1	Mount, Rubber	Support caoutchouc	Bloque de caucho
12	1664405M1		6	Tie, Cable	Attache câble	Enlace de Cable
13	3517731M1		1	Clip, Mounting	Collier de fixation	Argolla de fijación
14	D142787		1	Mount, Rubber	Support caoutchouc	Bloque de caucho
15	515-22127		4	Clip, Mounting	Collier de fixation	Argolla de fijación
16	6101777M91	Switch	1	Cover	Cache	Tapa
17	6102490M1		1	Relay	Relais	Relé



820 860 880 970 980
 TX760B TX860B

805 806 807 808 817 825 833 834 845 855 921 931

90001C01.1

6199042M3

1

Jan-06

Quick Attach, Digger
Accouplement Rapide
Acoplamiento rápido

Sideshift
Montage de Pelle Latéral
Excavadora de montaje horizontal

Standard Dipper
Balancier Standard
Balancín estándar

Miller
 Miller
 Miller

C-90001-02.1-A

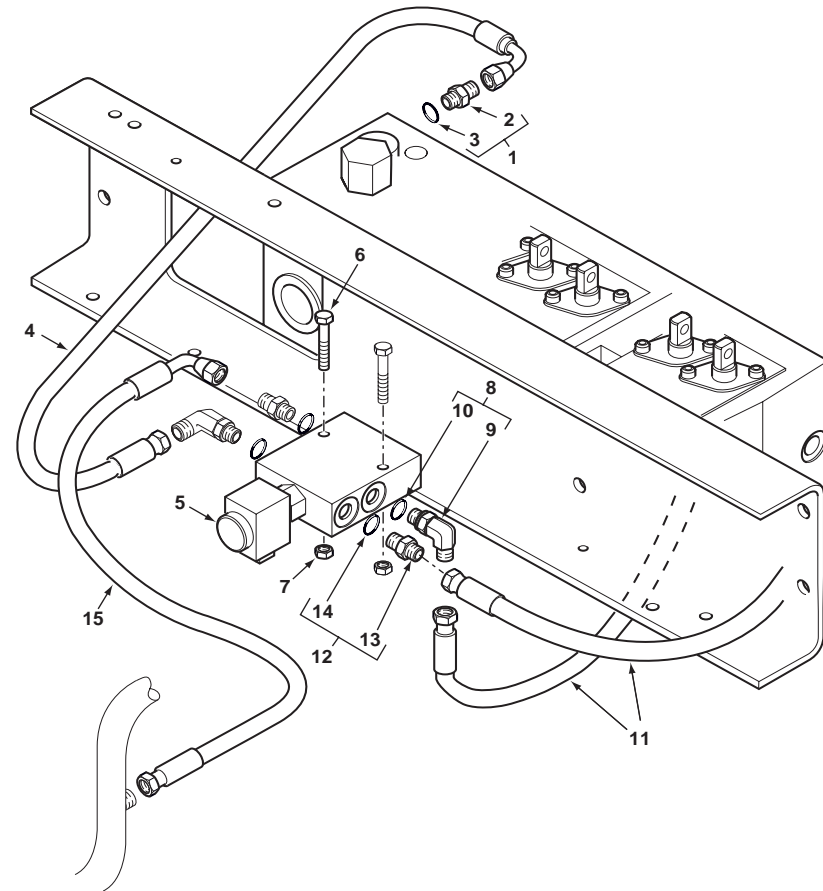

1	365830X91		1	Union	Union	Unión
2		1  Ref. 1	1	Union	Union	Unión
3		1	1	O-Ring	Joint torique	Junta de tipo O
4	6109910M91	Q/A Feed	1	Hose Assy	Ensemble de flexible	Flexible, Conj.
5	6106011M91	 98001C03.1	1	Valve, Solenoid	Électrovalve	Electroválvula
6	391244X1	M6 x 45	2	Bolt	Boulon	Perno
7	1441500X1	M6	2	Nut, Lock	Écrou de blocage	Tuerca de retención
8	370807X91		2	Elbow, 90°	Coude à 90°	Codo, 90°
9		8  Ref. 8	1	Elbow	Coude	Codo
10	831452M1	8	1	O-Ring	Joint torique	Junta de tipo O
11	6102806M91		2	Hose Assy	Ensemble de flexible	Flexible, Conj.
12	365065X91		2	Union	Union	Unión
13		12  Ref. 12	1	Union	Union	Unión
14	831452M1	12	1	O-Ring	Joint torique	Junta de tipo O
15	3519226M91	Q/A Return	1	Hose Assy	Ensemble de flexible	Flexible, Conj.



820 860 880 970 980
 TX760B TX860B

805 806 807 808 817 825 833 834 845 855 921 931

90001C02.1

6199042M3

1

Jan-06

Quick Attach, Digger
Accouplement Rapide
Acoplamiento rápido

Sideshift
Montage de Pelle Latéral
Excavadora de montaje horizontal

Solenoid Valve
 Electrovanne
 Electroválvula

C-90001-03.1-A

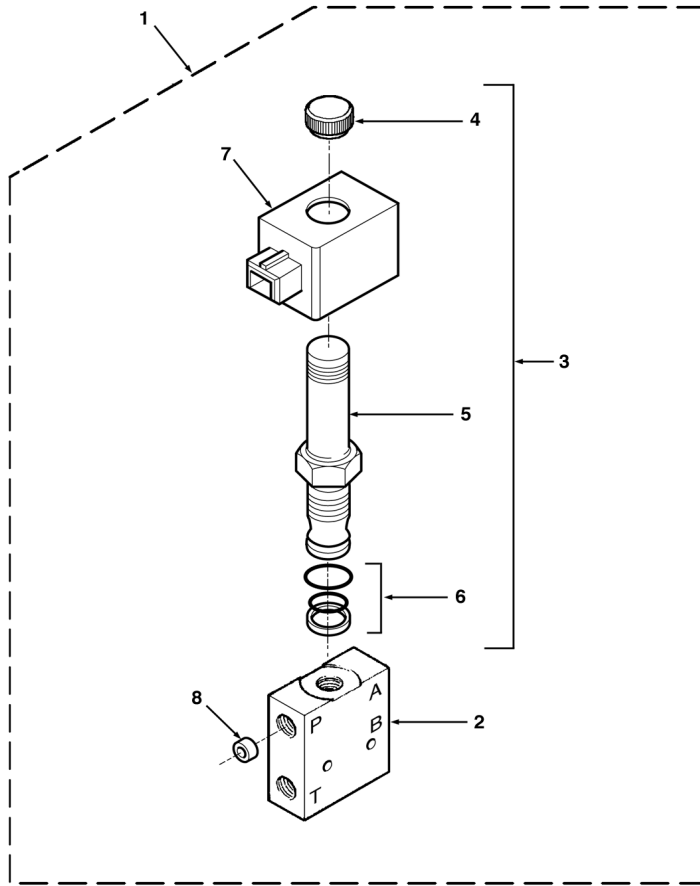

1	6106011M91		90001C02.1 5	1	Valve, Solenoid	Électrovalve	Electroválvula
2		1	Ref. 1	1	Body	Corps	Cuerpo
3	6193020M91	1		1	Solenoid Assy	Ensemble de solénoïde	Solenoïde, Conj.
4		3	Ref. 3	1	Nut	Écrou	Tuerca
5		3	Ref. 3	1	Cartridge	Cartouche	Cartucho
6	6193022M91	3		1	Kit, Seal	Pochette de joints	Juego de juntas
7	6191096M91	1	12V	1	Coil	Bobine	Bobina
8	6193021M1	1		1	Restrictor	Réduction	Reducción



820 860 880 970 980
 TX760B TX860B

805 806 807 808 817 825 833 834 845 855 921 931

90001C03.1

6199042M3

1

Jan-06

Quick Attach, Digger
Accouplement Rapide
Acoplamiento rápido

Sideshift
Montage de Pelle Latéral
Excavadora de montaje horizontal

Quick Coupler
Attache Rapide
Acoplamiento rápido

Miller
 Miller
 Miller

C-90001-04.1-A

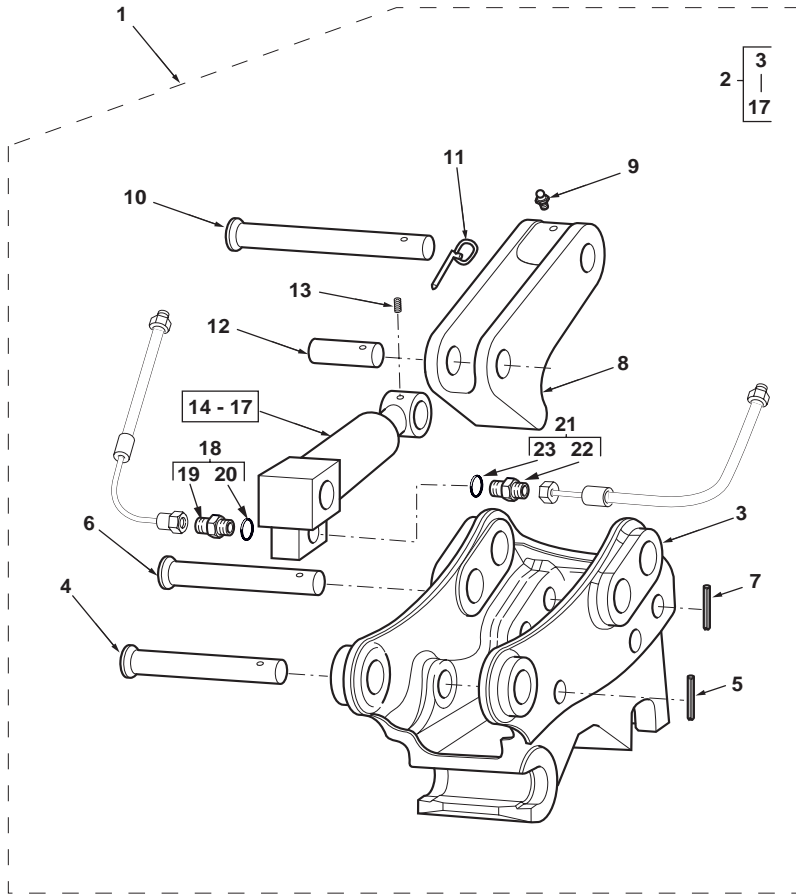

1	6108811M92			1	Hitch Assy, Quick	Ensem. D'attel. Rapide	Engan. rápido, Conj.
2	6102976M91	1		1	Hitch Assy, Quick	Ensem. D'attel. Rapide	Engan. rápido, Conj.
3	6193009M1	2		1	Body	Corps	Cuerpo
4	6193013M1	2	25 x 240 mm	1	Pin	Axe	Pasador
5	6193016M1	2		1	Pin, Roll	Goupille élastique	Pasador elástico
6	6193012M1	2	32 x 240 mm	1	Pin	Axe	Pasador
7	6193016M1	2		1	Pin, Roll	Goupille élastique	Pasador elástico
8	6193010M1	2		1	Hook	Crochet	Gancho
9	6193018M1	2		1	Fitting, Grease	Graisneur	Engrasador
10	6193015M1	2	32 x 240 mm	1	Pin	Axe	Pasador
11	6193017M1	2		1	Pin, Linch	Goupille d'arrêt	Pasador de parada
12	6193014M1	2	25 x 100 mm	1	Pin	Axe	Pasador
13	6193019M1	2		1	Screw	Vis	Tornillo
14	6193011M91	2		1	Cylinder Assy	Ensemble de vérin	Gato, Conj.
15	6193577M91	4	(A)	1	Valve, Check	Clapet anti-retour	Válvula de parada
16	6193578M91	4	(A)	1	Check Valve	Pochette de joints	Juego de juntas
17	6193576M91	4	(A)	1	Q/A Hyd. Cyl.	Pochette de joints	Juego de juntas
18	358741X91	1		1	Union	Union	Unión
19		18	➡ Ref. 18	1	Union	Union	Unión
20	831495M1	18		1	O-Ring	Joint torique	Junta de tipo O
21	6106088M91	1		1	Union	Union	Unión
22		21	➡ Ref. 21	1	Union	Union	Unión
23		21		1	O-Ring	Joint torique	Junta de tipo O

A Not illustrated
 Non illustrée
 No ilustrado



820 860 880 970 980
 TX760B TX860B

805 806 807 808 817 825 833 834 845 855 921 931

90001C04.1

6199042M3

1

Jan-06

Quick Attach, Digger
Accouplement Rapide
Acoplamiento rápido

Sideshift
Montage de Pelle Latéral
Excavadora de montaje horizontal

Standard Dipper
Balancier Standard
Balancín estándar

Less Q/A
Less Q/A
Less Q/A

C-90002-01.1-A

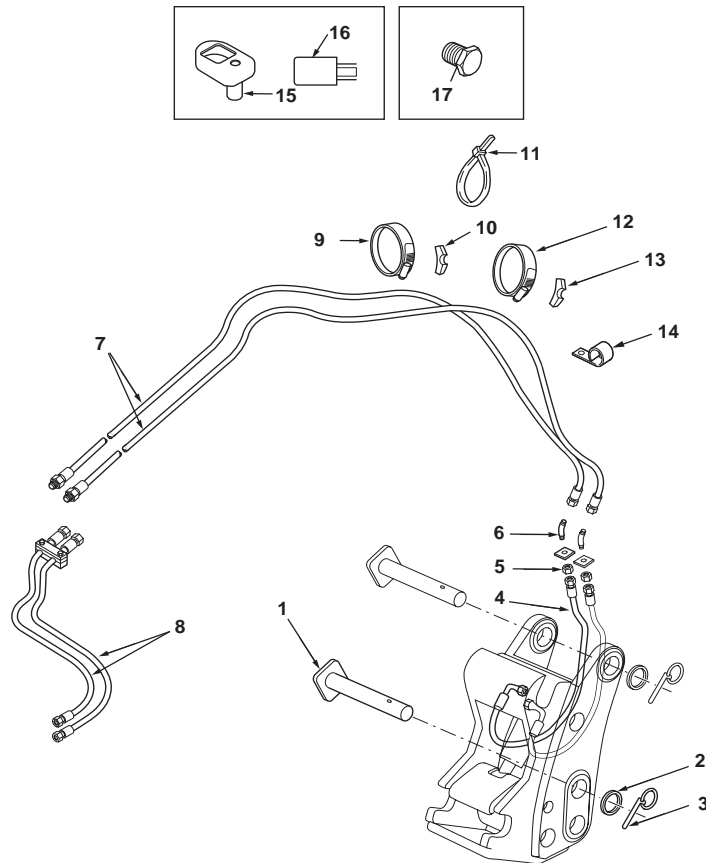

1	3516519M94	45 x 302 mm	2	Pin	Axe	Pasador
2	3501790M1		2	Washer	Rondelle	Arandela
3	3516522M91		2	Pin, Linch	Goupille d'arrêt	Pasador de parada
4	6102923M91		2	Hose Assy	Ensemble de flexible	Flexible, Conj.
5	356612X1	7/16" UNF	2	Nut	Écrou	Tuerca
6	371089X1		2	Elbow, 45°	Coude à 45°	Codo, 45°
7	6106086M91		2	Hose Assy	Ensemble de flexible	Flexible, Conj.
8		90002C02.1 11	2	Hose Assy	Ensemble de flexible	Flexible, Conj.
9	3517732M1		1	Clip, Mounting	Collier de fixation	Argolla de fijación
10	D142787		1	Mount, Rubber	Support caoutchouc	Bloque de caucho
11	1664405M1		6	Tie, Cable	Attache câble	Enlace de Cable
12	3517731M1		1	Clip, Mounting	Collier de fixation	Argolla de fijación
13	D142787		1	Mount, Rubber	Support caoutchouc	Bloque de caucho
14	515-22127		4	Clip, Mounting	Collier de fixation	Argolla de fijación
15	6101777M91	Switch	1	Cover	Cache	Tapa
16	6102490M1		1	Relay	Relais	Relé
17	218-772		2	Plug	Bouchon	Tapón



820 860 880 970 980
TX760B TX860B

805 806 807 808 817 825 833 834 845 855 921 931

90002C01.1

6199042M3

1

Jan-06

Quick Attach, Digger
Accouplement Rapide
Acoplamiento rápido

Sideshift
Montage de Pelle Latéral
Excavadora de montaje horizontal

Standard Dipper
Balancier Standard
Balancín estándar

Less Q/A
 Less Q/A
 Less Q/A

C-90002-02.1-A

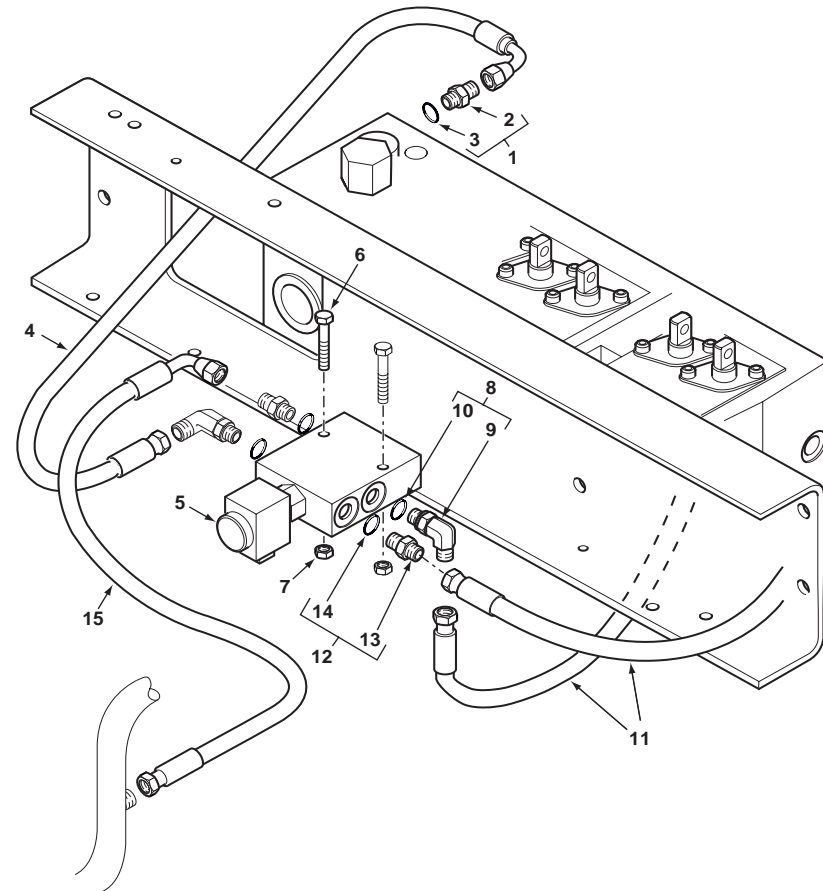

1	365830X91		1	Union	Union	Unión
2		1 Ref. 1	1	Union	Union	Unión
3		1	1	O-Ring	Joint torique	Junta de tipo O
4	6109910M91	Q/A Feed	1	Hose Assy	Ensemble de flexible	Flexible, Conj.
5	6106011M91	90002C03.1	1	Valve, Solenoid	Électrovalve	Electroválvula
6	391244X1	M6 x 45	2	Bolt	Boulon	Perno
7	1441500X1	M6	2	Nut, Lock	Écrou de blocage	Tuerca de retención
8	370807X91		2	Elbow, 90°	Coude à 90°	Codo, 90°
9		8 Ref. 8	1	Elbow	Coude	Codo
10	831452M1	8	1	O-Ring	Joint torique	Junta de tipo O
11	6102806M91		2	Hose Assy	Ensemble de flexible	Flexible, Conj.
12	365065X91		2	Union	Union	Unión
13		12 Ref. 12	1	Union	Union	Unión
14	831452M1	12	1	O-Ring	Joint torique	Junta de tipo O
15	3519226M91	Q/A Return	1	Hose Assy	Ensemble de flexible	Flexible, Conj.



820 860 880 970 980
 TX760B TX860B

805 806 807 808 817 825 833 834 845 855 921 931

90002C02.1

6199042M3

1

Jan-06

Quick Attach, Digger
Accouplement Rapide
Acoplamiento rápido

Sideshift
Montage de Pelle Latéral
Excavadora de montaje horizontal

Solenoid Valve
 Electrovanne
 Electroválvula

C-90002-03.1-A

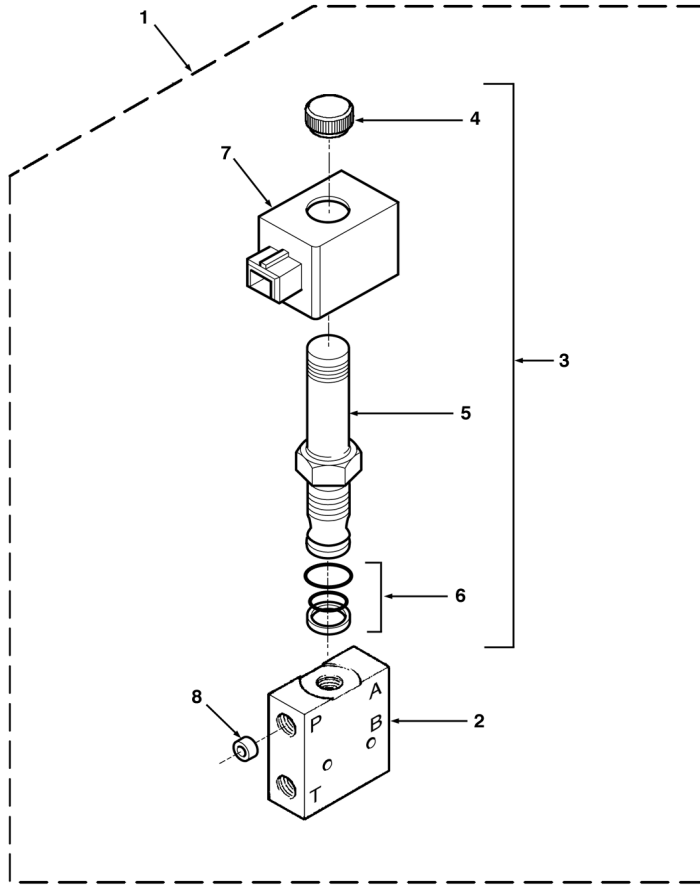

1	6106011M91		90002C02.1 5	1	Valve, Solenoid	Électrovalve	Electroválvula
2		1	Ref. 1	1	Body	Corps	Cuerpo
3	6193020M91	1		1	Solenoid Assy	Ensemble de solénoïde	Solenoïde, Conj.
4		3	Ref. 3	1	Nut	Écrou	Tuerca
5		3	Ref. 3	1	Cartridge	Cartouche	Cartucho
6	6193022M91	3		1	Kit, Seal	Pochette de joints	Juego de juntas
7	6191096M91	1	12V	1	Coil	Bobine	Bobina
8	6193021M1	1		1	Restrictor	Réduction	Reducción



820 860 880 970 980
 TX760B TX860B

805 806 807 808 817 825 833 834 845 855 921 931

90002C03.1

6199042M3

1

Jan-06

Quick Attach, Digger
Accouplement Rapide
Acoplamiento rápido

Sideshift
Montage de Pelle Latéral
Excavadora de montaje horizontal

Telescopic Dipper
Balancier Téléscopique
Balancín telescópico

Miller
 Miller
 Miller

C-90003-01.1-A

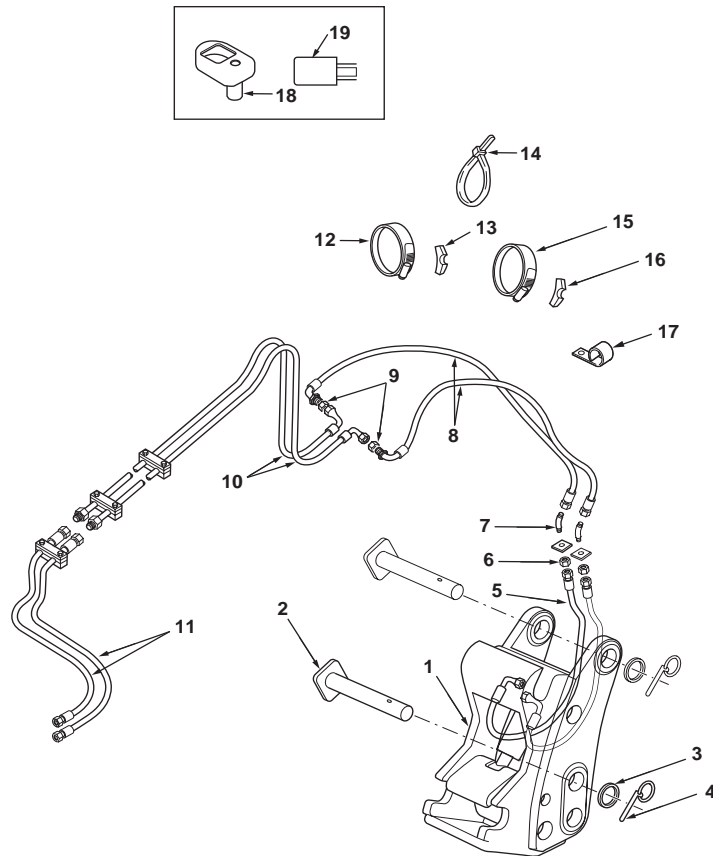

1	6108811M92	90003C04.1 1	1	Hitch Assy, Quick	Ensem. D'attel. Rapide	Engan. rápido, Conj.
2	3516519M94	45 x 302 mm	2	Pin	Axe	Pasador
3	3501790M1		2	Washer	Rondelle	Arandela
4	3516522M91		2	Pin, Linch	Goupille d'arrêt	Pasador de parada
5	6102923M91		2	Hose Assy	Ensemble de flexible	Flexible, Conj.
6	356612X1	7/16" UNF	2	Nut	Écrou	Tuerca
7	371089X1		2	Elbow, 45°	Coude à 45°	Codo, 45°
8	6102922M91		2	Hose Assy	Ensemble de flexible	Flexible, Conj.
9	356612X1	7/16" UNF	2	Nut	Écrou	Tuerca
10	3521945M95		2	Hose Assy	Ensemble de flexible	Flexible, Conj.
11		90003C02.1 11	2	Hose Assy	Ensemble de flexible	Flexible, Conj.
12	3517732M1		1	Clip, Mounting	Collier de fixation	Argolla de fijación
13	D142787		1	Mount, Rubber	Support caoutchouc	Bloque de caучо
14	1664405M1		6	Tie, Cable	Attache câble	Enlace de Cable
15	3517731M1		1	Clip, Mounting	Collier de fixation	Argolla de fijación
16	D142787		1	Mount, Rubber	Support caoutchouc	Bloque de caучо
17	515-22127		4	Clip, Mounting	Collier de fixation	Argolla de fijación
18	6101777M91	Switch	1	Cover	Cache	Tapa
19	6102490M1		1	Relay	Relais	Relé



820 860 880 970 980
 TX760B TX860B

805 806 807 808 817 825 833 834 845 855 921 931

90003C01.1

6199042M3

1

Jan-06

Quick Attach, Digger
Accouplement Rapide
Acoplamiento rápido

Sideshift
Montage de Pelle Latéral
Excavadora de montaje horizontal

Telescopic Dipper - Boom 4.5m
 Balancier Téléscopique - Flèche 4.5m
 Balancín telescópico - Pluma 4.5m

Miller
 Miller
 Miller

C-90003-02.1-A

1	365830X91			1	Union	Union	Unión
2		1	Ref. 1	1	Union	Union	Unión
3		1		1	O-Ring	Joint torique	Junta de tipo O
4	6109910M91		Q/A Feed	1	Hose Assy	Ensemble de flexible	Flexible, Conj.
5	6106011M91		98003C03.1	1	Valve, Solenoid	Électrovalve	Electroválvula
6	391244X1		M6 x 45	2	Bolt	Boulon	Perno
7	1441500X1		M6	2	Nut, Lock	Écrou de blocage	Tuerca de retención
8	370807X91			2	Elbow, 90°	Coude à 90°	Codo, 90°
9		8	Ref. 8	1	Elbow	Coude	Codo
10	831452M1		8	1	O-Ring	Joint torique	Junta de tipo O
11	6102806M91			2	Hose Assy	Ensemble de flexible	Flexible, Conj.
12	365065X91			2	Union	Union	Unión
13		12	Ref. 12	1	Union	Union	Unión
14	831452M1		12	1	O-Ring	Joint torique	Junta de tipo O
15	3519226M91		Q/A Return	1	Hose Assy	Ensemble de flexible	Flexible, Conj.

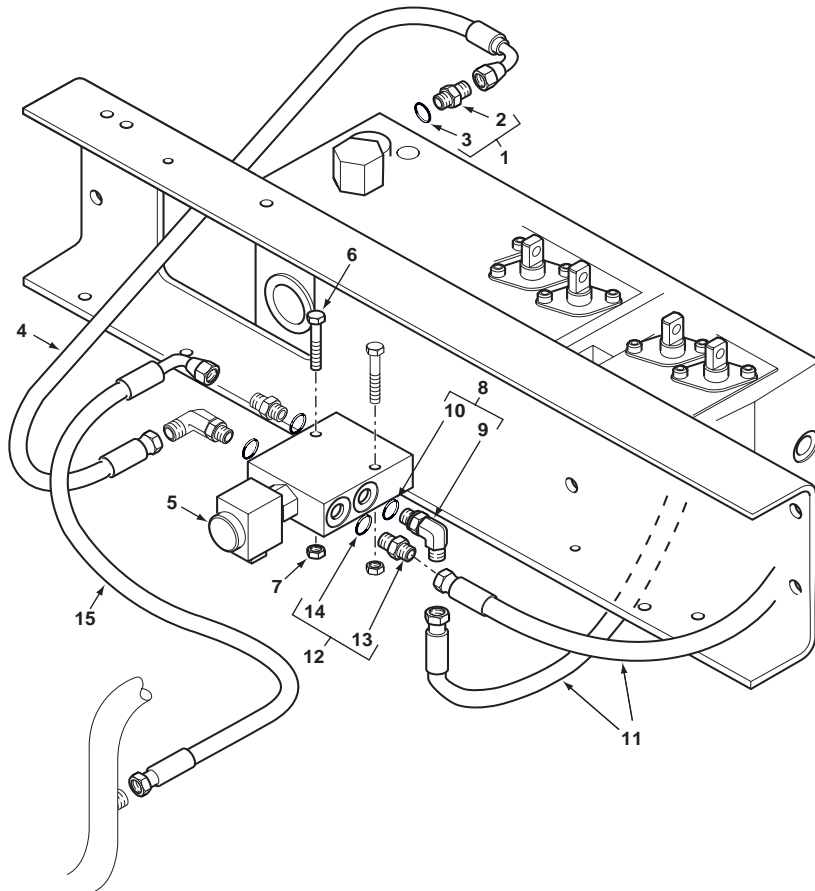

820 860 880 970 980
 TX760B TX860B

805 806 807 808 817 825 833 834 845 855 921 931

90003C02.1

6199042M3

1

Jan-06

Quick Attach, Digger
Accouplement Rapide
Acoplamiento rápido

Sideshift
Montage de Pelle Latéral
Excavadora de montaje horizontal

Solenoid Valve
 Electrovanne
 Electroválvula

C-90003-03.1-A

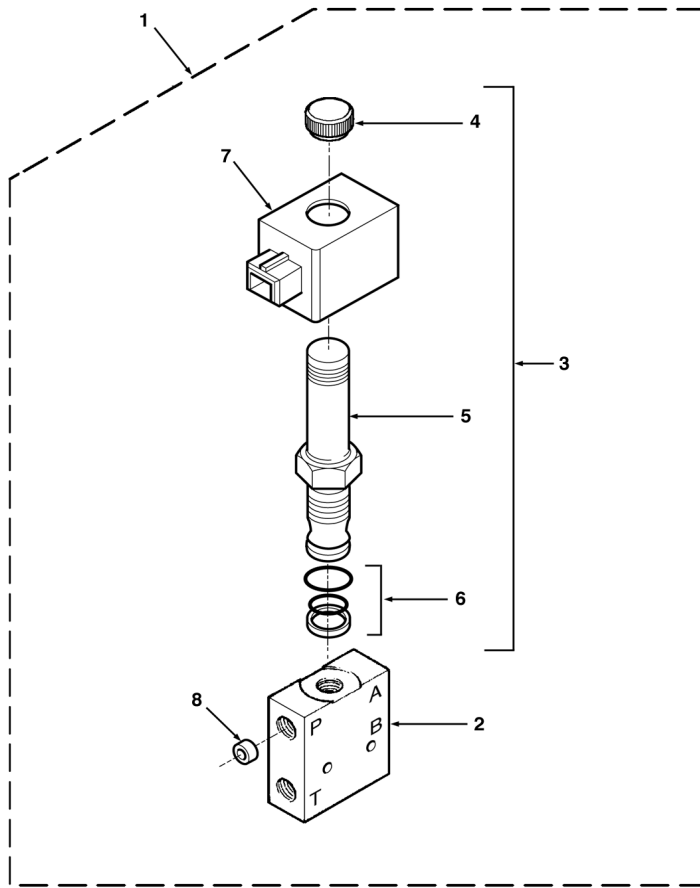

1	6106011M91		90003C02.1 5	1	Valve, Solenoid	Électrovalve	Electroválvula
2		1	Ref. 1	1	Body	Corps	Cuerpo
3	6193020M91	1		1	Solenoid Assy	Ensemble de solénoïde	Solenoïde, Conj.
4		3	Ref. 3	1	Nut	Écrou	Tuerca
5		3	Ref. 3	1	Cartridge	Cartouche	Cartucho
6	6193022M91	3		1	Kit, Seal	Pochette de joints	Juego de juntas
7	6191096M91	1	12V	1	Coil	Bobine	Bobina
8	6193021M1	1		1	Restrictor	Réduction	Reducción



820 860 880 970 980
 TX760B TX860B

805 806 807 808 817 825 833 834 845 855 921 931

90003C03.1

6199042M3

1

Jan-06

Quick Attach, Digger
Accouplement Rapide
Acoplamiento rápido

Sideshift
Montage de Pelle Latéral
Excavadora de montaje horizontal

Quick Coupler
Attache Rapide
Acoplamiento rápido

Miller
 Miller
 Miller

C-90003-04.1-A

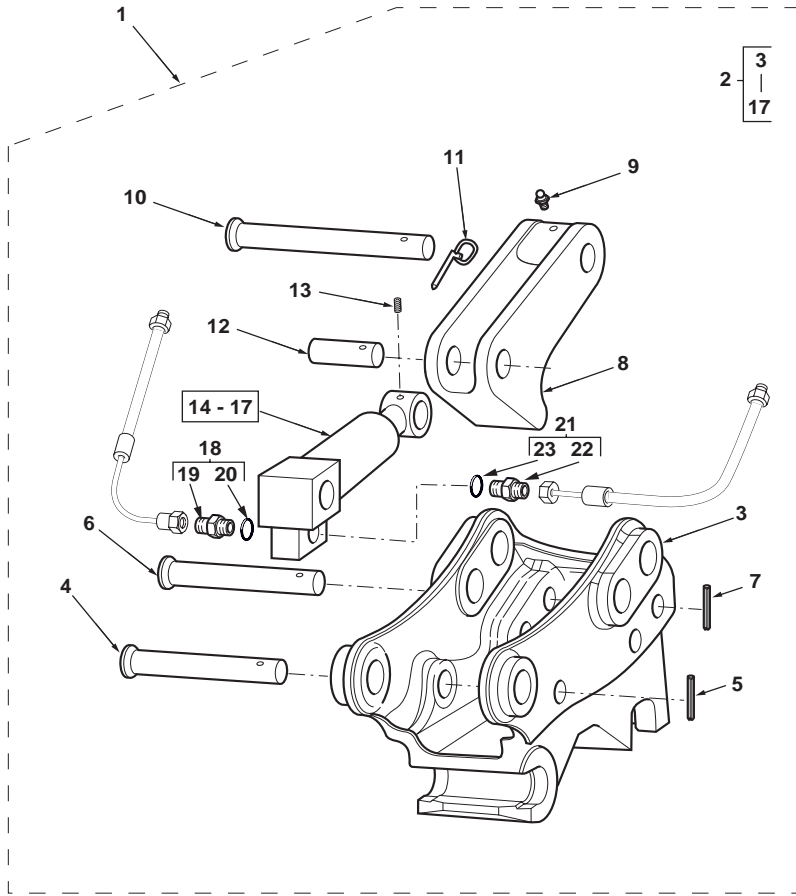

1	6108811M92			1	Hitch Assy, Quick	Ensem. D'attel. Rapide	Engan. rápido, Conj.
2	6102976M91	1		1	Hitch Assy, Quick	Ensem. D'attel. Rapide	Engan. rápido, Conj.
3	6193009M1	2		1	Body	Corps	Cuerpo
4	6193013M1	2	25 x 240 mm	1	Pin	Axe	Pasador
5	6193016M1	2		1	Pin, Roll	Goupille élastique	Pasador elástico
6	6193012M1	2	32 x 240 mm	1	Pin	Axe	Pasador
7	6193016M1	2		1	Pin, Roll	Goupille élastique	Pasador elástico
8	6193010M1	2		1	Hook	Crochet	Gancho
9	6193018M1	2		1	Fitting, Grease	Graisneur	Engrasador
10	6193015M1	2	32 x 240 mm	1	Pin	Axe	Pasador
11	6193017M1	2		1	Pin, Linch	Goupille d'arrêt	Pasador de parada
12	6193014M1	2	25 x 100 mm	1	Pin	Axe	Pasador
13	6193019M1	2		1	Screw	Vis	Tornillo
14	6193011M91	2		1	Cylinder Assy	Ensemble de vérin	Gato, Conj.
15	6193577M91	4	(A)	1	Valve, Check	Clapet anti-retour	Válvula de parada
16	6193578M91	4	(A)	1	Check Valve	Pochette de joints	Juego de juntas
17	6193576M91	4	(A)	1	Q/A Hyd. Cyl.	Pochette de joints	Juego de juntas
18	358741X91	1		1	Union	Union	Unión
19		18	➡ Ref. 18	1	Union	Union	Unión
20	831495M1	18		1	O-Ring	Joint torique	Junta de tipo O
21	6106088M91	1		1	Union	Union	Unión
22		21	➡ Ref. 21	1	Union	Union	Unión
23		21		1	O-Ring	Joint torique	Junta de tipo O

A Not illustrated
 Non illustrée
 No ilustrado



820 860 880 970 980
 TX760B TX860B

805 806 807 808 817 825 833 834 845 855 921 931

90003C04.1

6199042M3

1

Jan-06

Quick Attach, Digger
Accouplement Rapide
Acoplamiento rápido

Sideshift
Montage de Pelle Latéral
Excavadora de montaje horizontal

Telescopic Dipper
Balancier Téléscopique
Balancín telescópico

Less Q/A
 Less Q/A
 Less Q/A

C-90004-01.1-A

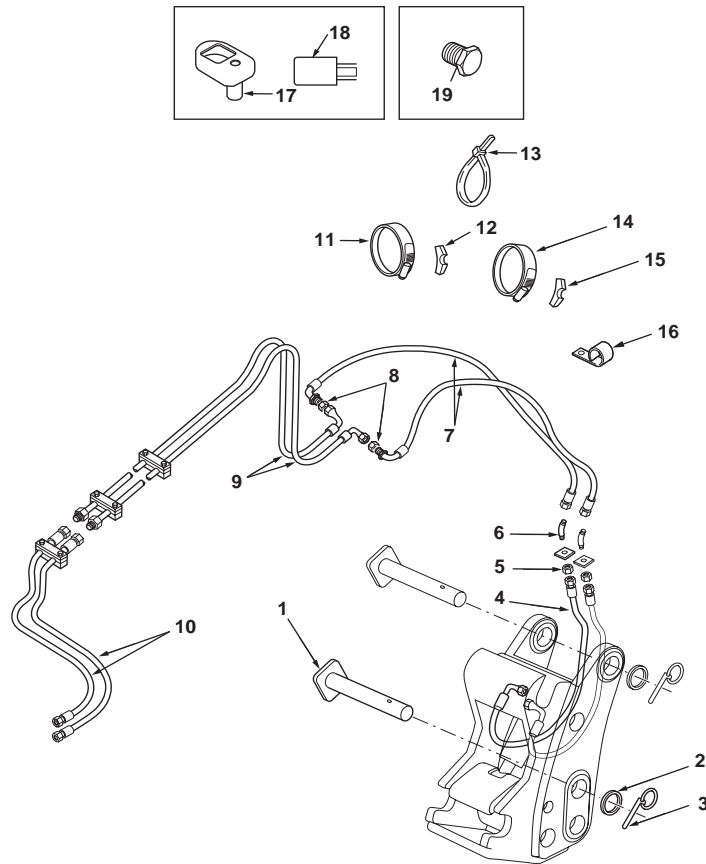

1	3516519M94	45 x 302 mm	2	Pin	Axe	Pasador
2	3501790M1		2	Washer	Rondelle	Arandela
3	3516522M91		2	Pin, Linch	Goupille d'arrêt	Pasador de parada
4	6102923M91		2	Hose Assy	Ensemble de flexible	Flexible, Conj.
5	356612X1	7/16" UNF	2	Nut	Écrou	Tuerca
6	371089X1		2	Elbow, 45°	Coude à 45°	Codo, 45°
7	6102922M91		2	Hose Assy	Ensemble de flexible	Flexible, Conj.
8	356612X1	7/16" UNF	2	Nut	Écrou	Tuerca
9	3521945M95		2	Hose Assy	Ensemble de flexible	Flexible, Conj.
10		90004C02.1 11	2	Hose Assy	Ensemble de flexible	Flexible, Conj.
11	3517732M1		1	Clip, Mounting	Collier de fixation	Argolla de fijación
12	D142787		1	Mount, Rubber	Support caoutchouc	Bloque de caoucho
13	1664405M1		6	Tie, Cable	Attache câble	Enlace de Cable
14	3517731M1		1	Clip, Mounting	Collier de fixation	Argolla de fijación
15	D142787		1	Mount, Rubber	Support caoutchouc	Bloque de caoucho
16	515-22127		4	Clip, Mounting	Collier de fixation	Argolla de fijación
17	6101777M91	Switch	1	Cover	Cache	Tapa
18	6102490M1		1	Relay	Relais	Relé
19	218-772		2	Plug	Bouchon	Tapón



820 860 880 970 980
 TX760B TX860B

805 806 807 808 817 825 833 834 845 855 921 931

90004C01.1

6199042M3

1

Jan-06

Quick Attach, Digger
Accouplement Rapide
Acoplamiento rápido

Sideshift
Montage de Pelle Latéral
Excavadora de montaje horizontal

Telescopic Dipper - Boom 4.5m
 Balancier Télescopique - Flèche 4.5m
 Balancín telescópico - Pluma 4.5m

Less Q/A
 Less Q/A
 Less Q/A

C-90004-02.1-A

1	365830X91			1	Union	Union	Unión
2		1	Ref. 1	1	Union	Union	Unión
3		1		1	O-Ring	Joint torique	Junta de tipo O
4	6109910M91		Q/A Feed	1	Hose Assy	Ensemble de flexible	Flexible, Conj.
5	6106011M91		98004C03.1	1	Valve, Solenoid	Électrovalve	Electroválvula
6	391244X1		M6 x 45	2	Bolt	Boulon	Perno
7	1441500X1		M6	2	Nut, Lock	Écrou de blocage	Tuerca de retención
8	370807X91			2	Elbow, 90°	Coude à 90°	Codo, 90°
9		8	Ref. 8	1	Elbow	Coude	Codo
10	831452M1		8	1	O-Ring	Joint torique	Junta de tipo O
11	6102806M91			2	Hose Assy	Ensemble de flexible	Flexible, Conj.
12	365065X91			2	Union	Union	Unión
13		12	Ref. 12	1	Union	Union	Unión
14	831452M1		12	1	O-Ring	Joint torique	Junta de tipo O
15	3519226M91		Q/A Return	1	Hose Assy	Ensemble de flexible	Flexible, Conj.

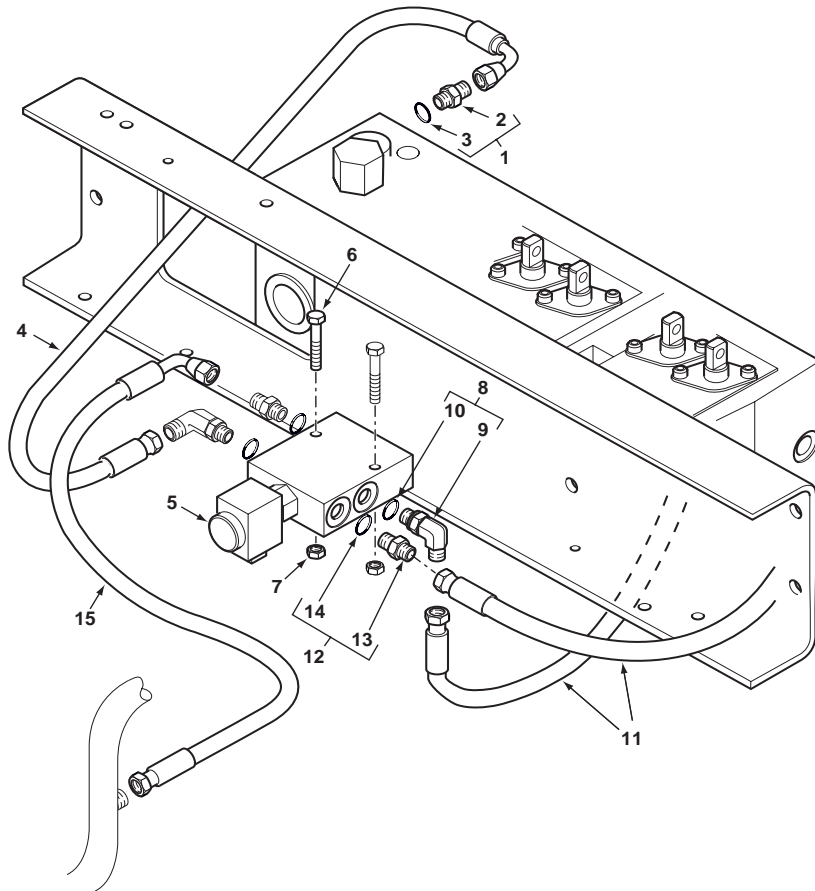

820 860 880 970 980
 TX760B TX860B

805 806 807 808 817 825 833 834 845 855 921 931

90004C02.1

6199042M3

1

Jan-06

Quick Attach, Digger
Accouplement Rapide
Acoplamiento rápido

Sideshift
Montage de Pelle Latéral
Excavadora de montaje horizontal

Solenoid Valve
 Electrovanne
 Electroválvula

C-90004-03.1-A

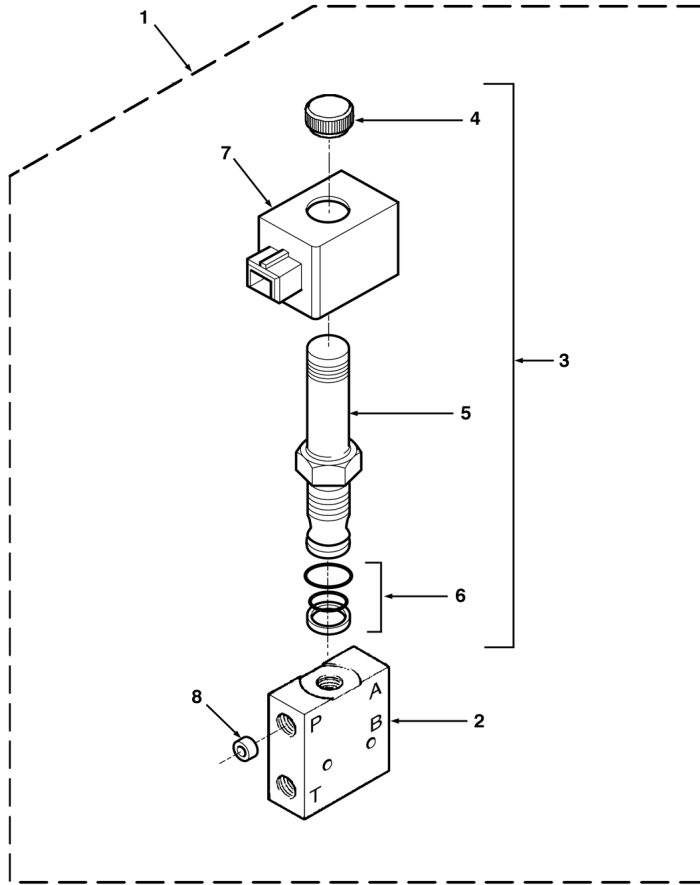

1	6106011M91		90004C02.1 5	1	Valve, Solenoid	Électrovalve	Electroválvula
2		1	Ref. 1	1	Body	Corps	Cuerpo
3	6193020M91	1		1	Solenoid Assy	Ensemble de solénoïde	Solenoïde, Conj.
4		3	Ref. 3	1	Nut	Écrou	Tuerca
5		3	Ref. 3	1	Cartridge	Cartouche	Cartucho
6	6193022M91	3		1	Kit, Seal	Pochette de joints	Juego de juntas
7	6191096M91	1	12V	1	Coil	Bobine	Bobina
8	6193021M1	1		1	Restrictor	Réduction	Reducción



820 860 880 970 980
 TX760B TX860B

805 806 807 808 817 825 833 834 845 855 921 931

90004C03.1

6199042M3

1

Jan-06

Quick Attach, Digger
Accouplement Rapide
Acoplamiento rápido

Sideshift
Montage de Pelle Latéral
Excavadora de montaje horizontal

Standard Dipper
Balancier Standard
Balancín estándar

JCB
 JCB
 JCB

C-90011-01.1-A

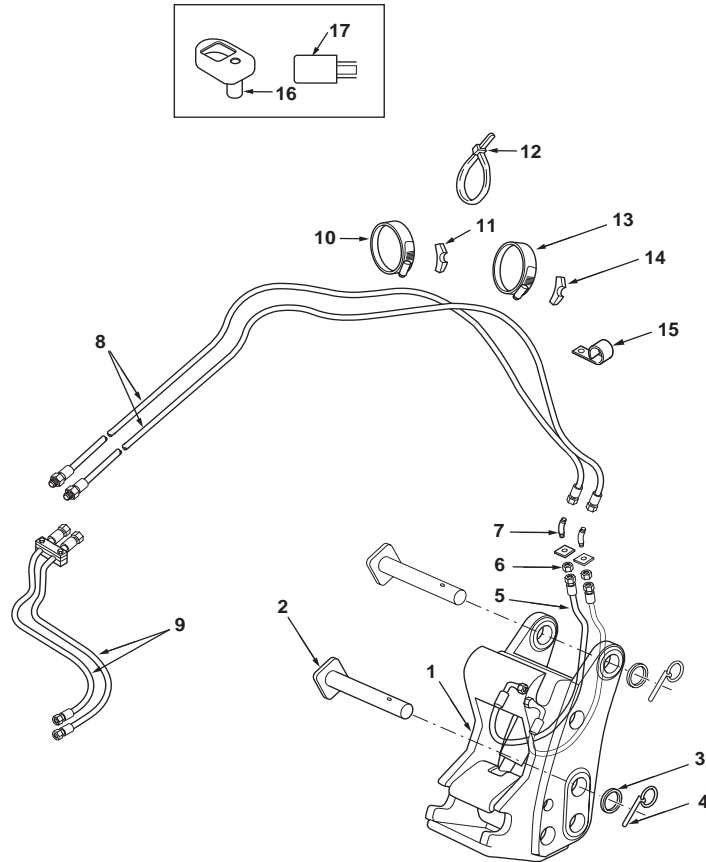

1	6110613M91	(A)	1	Hitch Assy, Quick	Ensem. D'attel. Rapide	Engan. rápido, Conj.
2	3516519M94	45 x 302 mm	2	Pin	Axe	Pasador
3	3501790M1		2	Washer	Rondelle	Arandela
4	3516522M91		2	Pin, Linch	Goupille d'arrêt	Pasador de parada
5	6102923M91		2	Hose Assy	Ensemble de flexible	Flexible, Conj.
6	356612X1	7/16" UNF	2	Nut	Écrou	Tuerca
7	371089X1		2	Elbow, 45°	Coude à 45°	Codo, 45°
8	6106086M91		2	Hose Assy	Ensemble de flexible	Flexible, Conj.
9		90011C02.1 11	2	Hose Assy	Ensemble de flexible	Flexible, Conj.
10	3517732M1		1	Clip, Mounting	Collier de fixation	Argolla de fijación
11	D142787		1	Mount, Rubber	Support caoutchouc	Bloque de caучо
12	1664405M1		6	Tie, Cable	Attache câble	Enlace de Cable
13	3517731M1		1	Clip, Mounting	Collier de fixation	Argolla de fijación
14	D142787		1	Mount, Rubber	Support caoutchouc	Bloque de caучо
15	515-22127		4	Clip, Mounting	Collier de fixation	Argolla de fijación
16	6101777M91	Switch	1	Cover	Cache	Tapa
17	6102490M1		1	Relay	Relais	Relé

A Details to be advised
 Détails à demander
 Detalles que deben ser notificados



880 980
 TX760B TX860B

833 834 845 855 931

90011C01.1

6199042M3

1

Jan-06



Quick Attach, Digger
Accouplement Rapide
Acoplamiento rápido

Sideshift
Montage de Pelle Latéral
Excavadora de montaje horizontal

Standard Dipper
 Balancier Standard
 Balancín estándar

JCB
 JCB
 JCB

C-90011-02.1-A

1	365830X91		1	Union	Union	Unión
2		1  Ref. 1	1	Union	Union	Unión
3		1	1	O-Ring	Joint torique	Junta de tipo O
4	6109910M91	Q/A Feed	1	Hose Assy	Ensemble de flexible	Flexible, Conj.
5	6106011M91	 98011C03.1	1	Valve, Solenoid	Électrovalve	Electroválvula
6	391244X1	M6 x 45	2	Bolt	Boulon	Perno
7	1441500X1	M6	2	Nut, Lock	Écrou de blocage	Tuerca de retención
8	370807X91		2	Elbow, 90°	Coude à 90°	Codo, 90°
9		8  Ref. 8	1	Elbow	Coude	Codo
10	831452M1	8	1	O-Ring	Joint torique	Junta de tipo O
11	6102806M91		2	Hose Assy	Ensemble de flexible	Flexible, Conj.
12	365065X91		2	Union	Union	Unión
13		12  Ref. 12	1	Union	Union	Unión
14	831452M1	12	1	O-Ring	Joint torique	Junta de tipo O
15	3519226M91	Q/A Return	1	Hose Assy	Ensemble de flexible	Flexible, Conj.

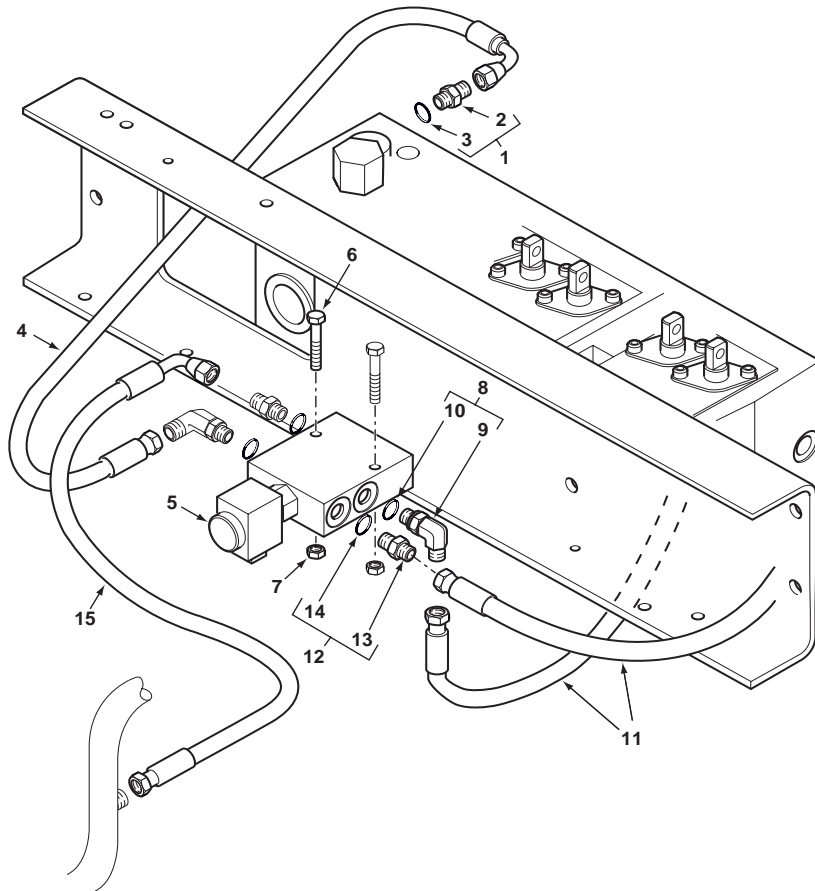

880 980
 TX760B TX860B

833 834 845 855 931

90011C02.1

6199042M3

1

Jan-06

Quick Attach, Digger
Accouplement Rapide
Acoplamiento rápido

Sideshift
Montage de Pelle Latéral
Excavadora de montaje horizontal

Solenoid Valve
 Electrovanne
 Electroválvula

C-90011-03.1-A

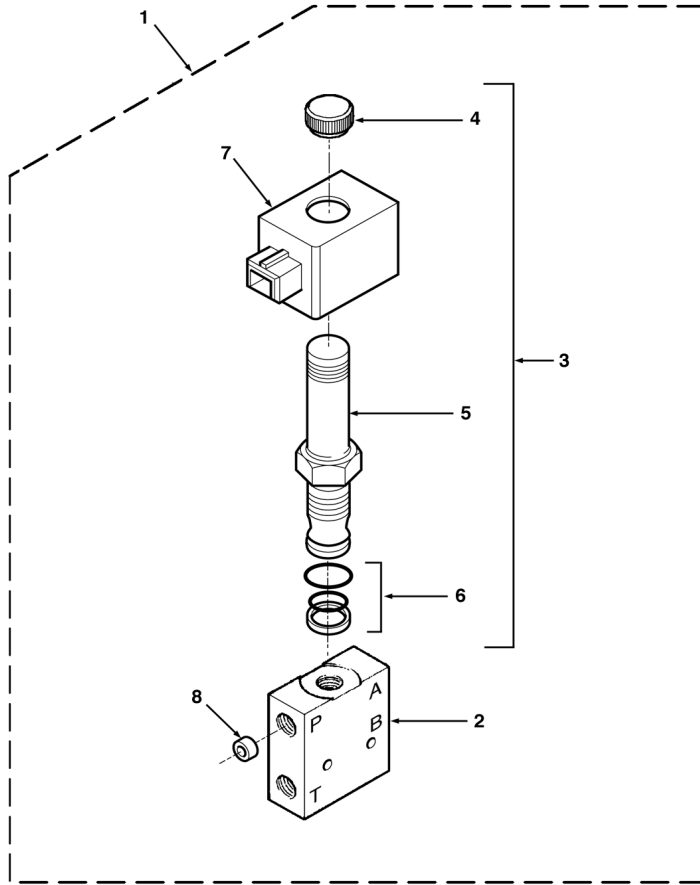

1	6106011M91		90011C02.1 5	1	Valve, Solenoid	Électrovalve	Electroválvula
2		1	Ref. 1	1	Body	Corps	Cuerpo
3	6193020M91	1		1	Solenoid Assy	Ensemble de solénoïde	Solenoid, Conj.
4		3	Ref. 3	1	Nut	Écrou	Tuerca
5		3	Ref. 3	1	Cartridge	Cartouche	Cartucho
6	6193022M91	3		1	Kit, Seal	Pochette de joints	Juego de juntas
7	6191096M91	1	12V	1	Coil	Bobine	Bobina
8	6193021M1	1		1	Restrictor	Réduction	Reducción



880 980
 TX760B TX860B

833 834 845 855 931

90011C03.1

6199042M3

1

Jan-06

Quick Attach, Digger
Accouplement Rapide
Acoplamiento rápido

Sideshift
Montage de Pelle Latéral
Excavadora de montaje horizontal

Telescopic Dipper
Balancier Téléscopique
Balancín telescópico

JCB
 JCB
 JCB

C-90012-01.1-A

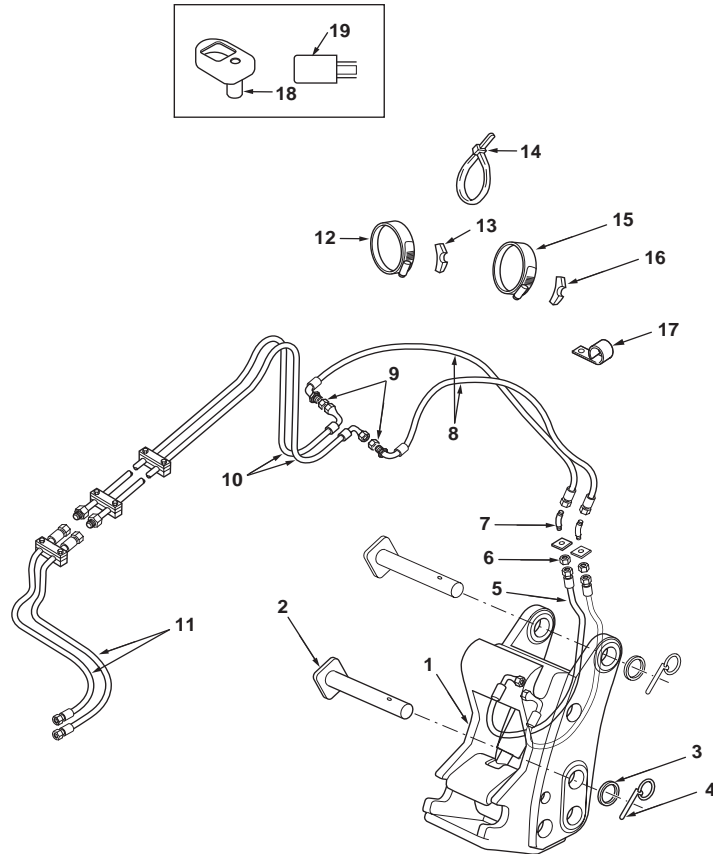

1	6110613M91	(A)	1	Hitch Assy, Quick	Ensem. D'attel. Rapide	Engan. rápido, Conj.
2	3516519M94	45 x 302 mm	2	Pin	Axe	Pasador
3	3501790M1		2	Washer	Rondelle	Arandela
4	3516522M91		2	Pin, Linch	Goupille d'arrêt	Pasador de parada
5	6102923M91		2	Hose Assy	Ensemble de flexible	Flexible, Conj.
6	356612X1	7/16" UNF	2	Nut	Écrou	Tuerca
7	371089X1		2	Elbow, 45°	Coude à 45°	Codo, 45°
8	6102922M91		2	Hose Assy	Ensemble de flexible	Flexible, Conj.
9	356612X1	7/16" UNF	2	Nut	Écrou	Tuerca
10	3521945M95		2	Hose Assy	Ensemble de flexible	Flexible, Conj.
11		90012C02.1 11	2	Hose Assy	Ensemble de flexible	Flexible, Conj.
12	3517732M1		1	Clip, Mounting	Collier de fixation	Argolla de fijación
13	D142787		1	Mount, Rubber	Support caoutchouc	Bloque de caucho
14	1664405M1		6	Tie, Cable	Attache câble	Enlace de Cable
15	3517731M1		1	Clip, Mounting	Collier de fixation	Argolla de fijación
16	D142787		1	Mount, Rubber	Support caoutchouc	Bloque de caucho
17	515-22127		4	Clip, Mounting	Collier de fixation	Argolla de fijación
18	6101777M91	Switch	1	Cover	Cache	Tapa
19	6102490M1		1	Relay	Relais	Relé

A Details to be advised
 Détails à demander
 Detalles que deben ser notificados



880 980
 TX760B TX860B

833 834 845 855 931

90012C01.1

6199042M3

1

Jan-06

Quick Attach, Digger
Accouplement Rapide
Acoplamiento rápido

Sideshift
Montage de Pelle Latéral
Excavadora de montaje horizontal

Telescopic Dipper - Boom 4.5m
 Balancier Télescopique - Flèche 4.5m
 Balancín telescópico - Pluma 4.5m

JCB
 JCB
 JCB

C-90012-02.1-A

1	365830X91			1	Union	Union	Unión
2		1	Ref. 1	1	Union	Union	Unión
3		1		1	O-Ring	Joint torique	Junta de tipo O
4	6109910M91		Q/A Feed	1	Hose Assy	Ensemble de flexible	Flexible, Conj.
5	6106011M91		98012C03.1	1	Valve, Solenoid	Électrovalve	Electroválvula
6	391244X1		M6 x 45	2	Bolt	Boulon	Perno
7	1441500X1		M6	2	Nut, Lock	Écrou de blocage	Tuerca de retención
8	370807X91			2	Elbow, 90°	Coude à 90°	Codo, 90°
9		8	Ref. 8	1	Elbow	Coude	Codo
10	831452M1		8	1	O-Ring	Joint torique	Junta de tipo O
11	6102806M91			2	Hose Assy	Ensemble de flexible	Flexible, Conj.
12	365065X91			2	Union	Union	Unión
13		12	Ref. 12	1	Union	Union	Unión
14	831452M1		12	1	O-Ring	Joint torique	Junta de tipo O
15	3519226M91		Q/A Return	1	Hose Assy	Ensemble de flexible	Flexible, Conj.

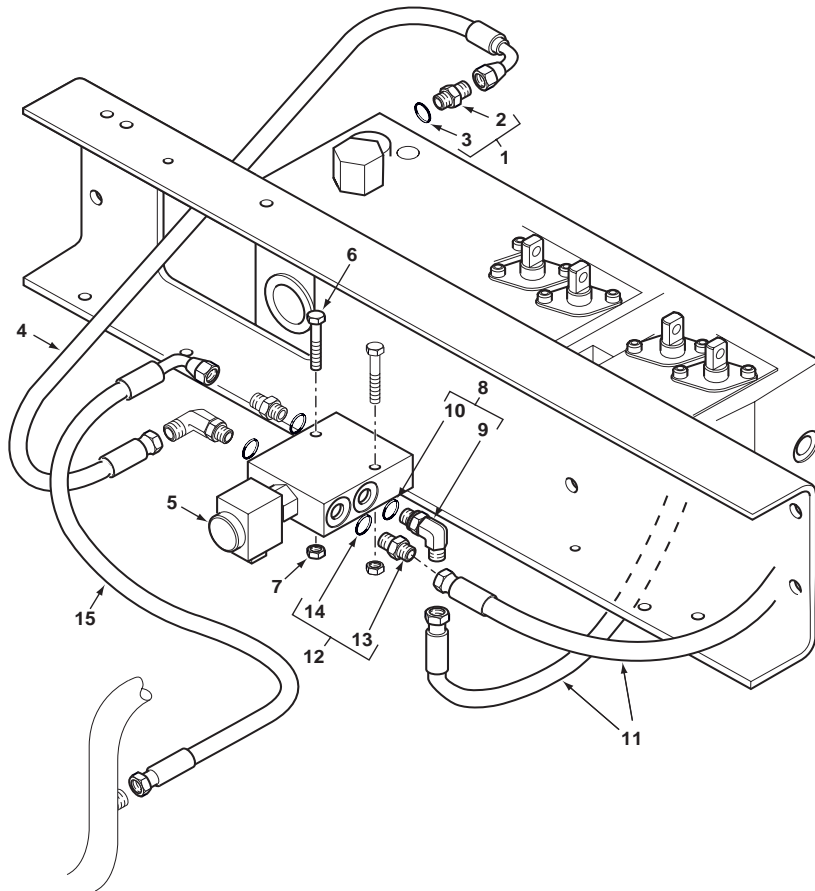

880 980
 TX760B TX860B

833 834 845 855 931

90012C02.1

6199042M3

1

Jan-06

Quick Attach, Digger
Accouplement Rapide
Acoplamiento rápido

Sideshift
Montage de Pelle Latéral
Excavadora de montaje horizontal

Solenoid Valve
Électrovanne
Electroválvula

C-90012-03.1-A

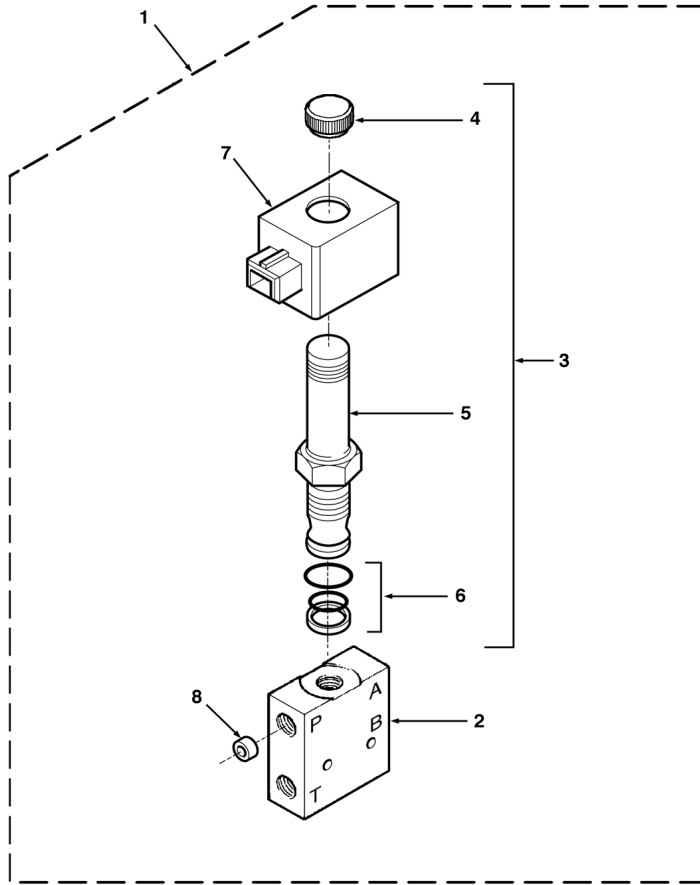

1	6106011M91		90012C02.1 5	1	Valve, Solenoid	Électrovalve	Electroválvula
2		1	Ref. 1	1	Body	Corps	Cuerpo
3	6193020M91	1		1	Solenoid Assy	Ensemble de solénoïde	Solenoid, Conj.
4		3	Ref. 3	1	Nut	Écrou	Tuerca
5		3	Ref. 3	1	Cartridge	Cartouche	Cartucho
6	6193022M91	3		1	Kit, Seal	Pochette de joints	Juego de juntas
7	6191096M91	1	12V	1	Coil	Bobine	Bobina
8	6193021M1	1		1	Restrictor	Réduction	Reducción



880 980
 TX760B TX860B

833 834 845 855 931

90012C03.1

6199042M3

1

Jan-06

D - Digger Boom and Dipperstick • Flèche et bras de pelle • Aguilón y pluma de la excavadora

Boom.....	72001C01.1	Flèche	Pluma
Boom.....	72002C01.1	Flèche	Pluma
Boom Transport Lock.....	69001C01.1	Verrouillage de Transport de Flèche	Bloqueo de transporte de pluma
Boom Transport Lock.....	69002C01.1	Verrouillage de Transport de Flèche	Bloqueo de transporte de pluma
Digger Bucket Linkage.....	74001AC01.1	Articulations Godet de Défonceuse	Articulaciones de cuchara retro
Digger Bucket Linkage.....	74001C01.1	Articulations Godet de Défonceuse	Articulaciones de cuchara retro
Digger Bucket Linkage - Case Buckets.....	74003AC01.1	Articulations Godet de Défonceuse - Godets Case	Articulaciones de cuchara retro - Cucharas case
Digger Bucket Linkage - Case Buckets.....	74003C01.1	Articulations Godet de Défonceuse - Godets Case	Articulaciones de cuchara retro - Cucharas case
Digger Bucket Linkage - JCB Buckets.....	74002C01.1	Articulations Godet de Défonceuse - Godets JCB	Articulaciones de cuchara retro - Cucharas JCB
Digger Controls.....	77001C01.1	Commandes Défonceuse	Mandos de equipo retro
Digger Controls.....	77002C01.1	Commandes Défonceuse	Mandos de equipo retro
Digger Controls.....	77003C01.1	Commandes Défonceuse	Mandos de equipo retro
Digger Controls - Servo.....	77007C01.1	Commandes Défonceuse - Servo	Mandos de equipo retro - Servo
Digger Controls - Servo.....	77007C02.1	Commandes Défonceuse - Servo	Mandos de equipo retro - Servo
Digger Controls - Servo.....	77007C03.1	Commandes Défonceuse - Servo	Mandos de equipo retro - Servo
Digger Controls - Servo.....	77007C04.1	Commandes Défonceuse - Servo	Mandos de equipo retro - Servo
Digger Controls - Servo.....	77007C05.1	Commandes Défonceuse - Servo	Mandos de equipo retro - Servo
Digger Controls - Servo.....	77007C06.1	Commandes Défonceuse - Servo	Mandos de equipo retro - Servo
Digger Controls - Servo.....	77008C01.1	Commandes Défonceuse - Servo	Mandos de equipo retro - Servo
Digger Controls - Servo.....	77008C02.1	Commandes Défonceuse - Servo	Mandos de equipo retro - Servo
Digger Controls - Servo.....	77008C03.1	Commandes Défonceuse - Servo	Mandos de equipo retro - Servo
Digger Controls - Servo.....	77008C04.1	Commandes Défonceuse - Servo	Mandos de equipo retro - Servo
Digger Controls - Servo.....	77008C05.1	Commandes Défonceuse - Servo	Mandos de equipo retro - Servo
Digger Controls - Servo.....	77008C06.1	Commandes Défonceuse - Servo	Mandos de equipo retro - Servo
Dipper - Extendahoe.....	73002C01.1	Balancier - Extendahoe	Balancín - Extendahoe
Dipper - Extendahoe.....	73002C02.1	Balancier - Extendahoe	Balancín - Extendahoe
Dipper - Extendahoe.....	73004C01.1	Balancier - Extendahoe	Balancín - Extendahoe
Dipper - Extendahoe.....	73004C02.1	Balancier - Extendahoe	Balancín - Extendahoe
Dipper - Extendahoe.....	73006C01.1	Balancier - Extendahoe	Balancín - Extendahoe
Dipper - Extendahoe.....	73006C02.1	Balancier - Extendahoe	Balancín - Extendahoe
Dipper - Standard.....	73001AC01.1	Balancier - Standard	Balancín - Estándar
Dipper - Standard.....	73001C01.1	Balancier - Standard	Balancín - Estándar
Dipper - Standard.....	73003AC01.1	Balancier - Standard	Balancín - Estándar
Dipper - Standard.....	73003C01.1	Balancier - Standard	Balancín - Estándar
Dipper - Standard.....	73005C01.1	Balancier - Standard	Balancín - Estándar
Less Dipper.....	73007C01.1	Sans balancier	Sin balancín
Stabiliser Controls.....	79005C01.1	Commandes Stabilisateurs	Mandos de estabilizadores
Stabiliser Controls.....	79006C01.1	Commandes Stabilisateurs	Mandos de estabilizadores



D - Digger Boom and Dipperstick • Flèche et bras de pelle • Aguilón y pluma de la excavadora

Stabiliser Controls - Centremount Digger.....	79002C01.1	Commandes Stabilisateurs - Montage de Pelle Central	Mandos de estabilizadores - Excavadora de montaje central
Stabiliser Controls - Centremount Digger.....	79002C02.1	Commandes Stabilisateurs - Montage de Pelle Central	Mandos de estabilizadores - Excavadora de montaje central
Stabiliser Controls - Centremount Digger.....	79003C01.1	Commandes Stabilisateurs - Montage de Pelle Central	Mandos de estabilizadores - Excavadora de montaje central
Stabiliser Controls - Sideshift Digger.....	79001C01.1	Commandes Stabilisateurs - Montage de Pelle Latéral	Mandos de estabilizadores - Excavadora de montaje lateral
Stabiliser Controls - Sideshift Digger.....	79001C02.1	Commandes Stabilisateurs - Montage de Pelle Latéral	Mandos de estabilizadores - Excavadora de montaje lateral
Stabiliser Controls - Sideshift Digger.....	79004C01.1	Commandes Stabilisateurs - Montage de Pelle Latéral	Mandos de estabilizadores - Excavadora de montaje lateral



Boom
Flèche
Pluma

C-72001-01.1-A

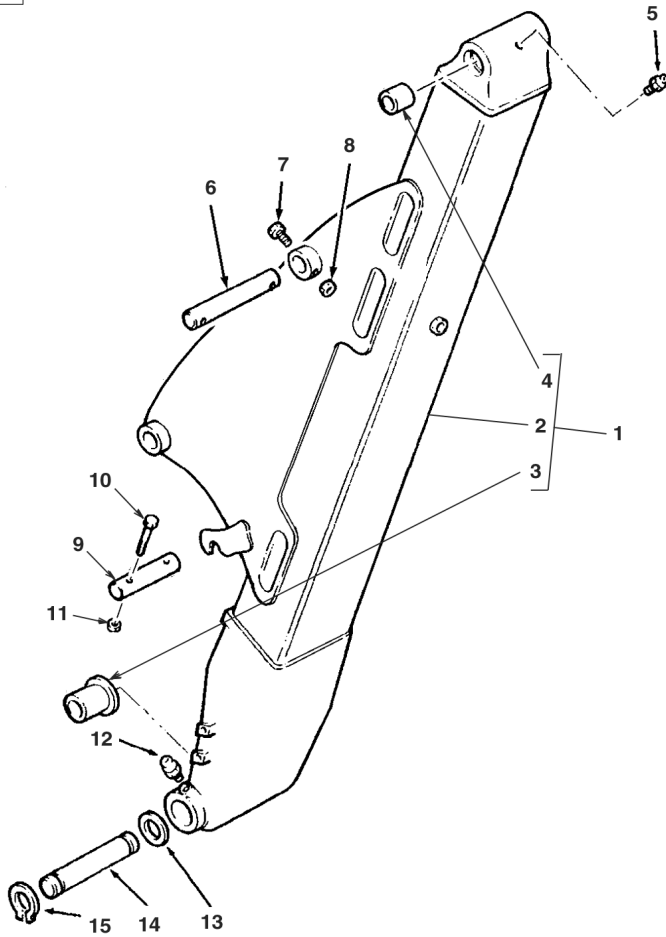

1	6102873M93	4.5m	1	Boom	Flèche	Pluma
2		1 Ref. 1	1	Boom	Flèche	Pluma
3	3501015M2	1	2	Bushing	Bague	Anillo
4	3500009M3	1	2	Bushing	Bague	Anillo
5	339608X1		1	Fitting, Grease	Graisseur	Engrasador
6	6102877M2	45 x 267 mm	2	Pin	Axe	Pasador
7	3501289M1	M10 x 110	2	Screw	Vis	Tornillo
8	1440329X1	M10	2	Nut, Lock	Écrou de blocage	Tuerca de retención
9	3522697M2	45 x 200 mm	1	Pin	Axe	Pasador
10	1442487X1	M10 x 130	1	Screw	Vis	Tornillo
11	1440329X1	M10	1	Nut, Lock	Écrou de blocage	Tuerca de retención
12	339608X1		1	Fitting, Grease	Graisseur	Engrasador
13	3519378M1		2	Washer	Rondelle	Arandela
14	3522698M2	50 x 325 mm	1	Pin	Axe	Pasador
15	391129X1		2	Ring, Snap	Anneau d'arrêt	Anillo de resorte



820 860 880 970 980
TX760B TX860B

801 802 803 804 805 806 807 808 809 810 813 814 817 821 822 825 831 832 833
834 841 842 845 851 852 855 921 922 931

72001C01.1

6199042M3

1

Jan-06

Boom
Flèche
Pluma

C-72002-01.1-A

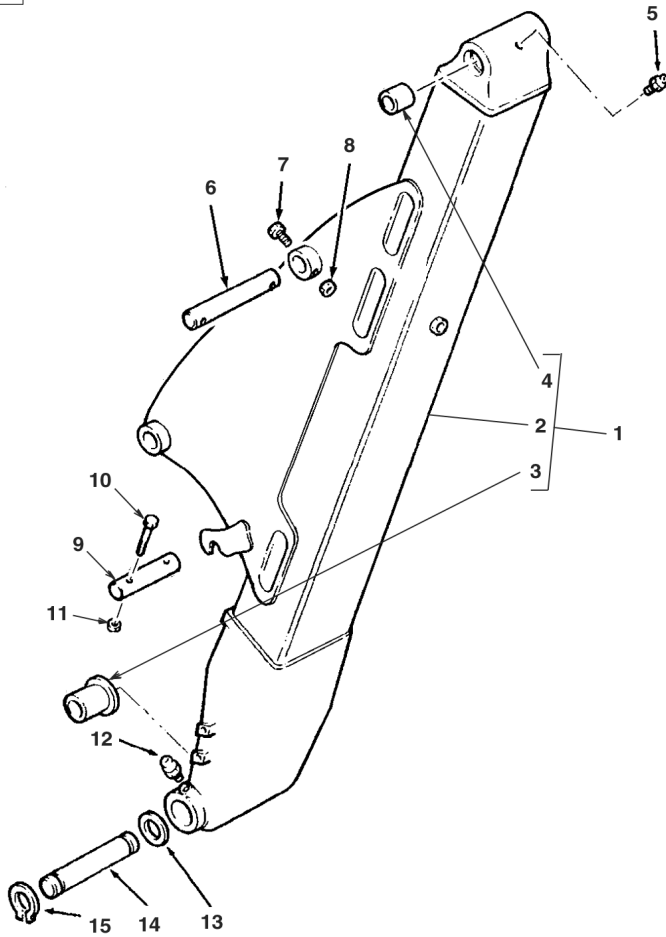

1	6102875M93	4.9m	1	Boom	Flèche	Pluma
2		1 Ref. 1	1	Boom	Flèche	Pluma
3	3501015M2	1	2	Bushing	Bague	Anillo
4	3500009M3	1	2	Bushing	Bague	Anillo
5	339608X1		1	Fitting, Grease	Graisseur	Engrasador
6	6102877M2	45 x 267 mm	2	Pin	Axe	Pasador
7	3501289M1	M10 x 110	2	Screw	Vis	Tornillo
8	1440329X1	M10	2	Nut, Lock	Écrou de blocage	Tuerca de retención
9	3522697M2	45 x 200 mm	1	Pin	Axe	Pasador
10	1442487X1	M10 x 130	1	Screw	Vis	Tornillo
11	1440329X1	M10	1	Nut, Lock	Écrou de blocage	Tuerca de retención
12	339608X1		1	Fitting, Grease	Graisseur	Engrasador
13	3519378M1		2	Washer	Rondelle	Arandela
14	3522698M2	50 x 325 mm	1	Pin	Axe	Pasador
15	391129X1		2	Ring, Snap	Anneau d'arrêt	Anillo de resorte



860 880 970 980
TX870B TX970B

811 812 815 816 823 824 843 844 853 854 923 932

72002C01.1

6199042M3

1

Jan-06

Boom Transport Lock
Verrouillage de Transport de Flèche
Bloqueo de transporte de pluma

Sideshift digger
 Montage de pelle latéral
 Excavadora de montaje horizontal

C-69001-01.1-A

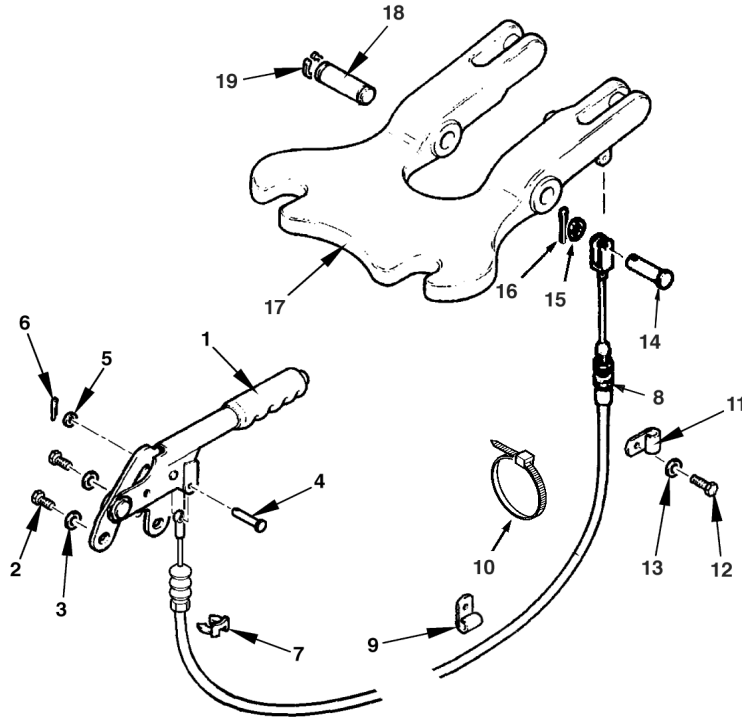

1	3522379M92		1	Lever, Control	Levier de commande	Palanca de mando
2	339124X1	M8 x 16	2	Screw	Vis	Tornillo
3	390972X1	M8	2	Washer	Rondelle	Arandela
4	3019192X1	dia 6	1	Pin	Axe	Pasador
5	390971X1	M6	1	Washer	Rondelle	Arandela
6	1442864X1		1	Pin, Split	Goupille	Pasador
7	3522777M1		1	Clip	Clip	Clip
8	6106281M91		1	Cable Assy	Ensemble de câble	Cable, Conj.
9	3517114M2		2	Clip, Mounting	Collier de fixation	Argolla de fijación
10	1664405M1		4	Tie, Cable	Attache câble	Enlace de Cable
11	3517114M2		1	Clip, Mounting	Collier de fixation	Argolla de fijación
12	339124X1	M8 x 16	1	Screw	Vis	Tornillo
13	390972X1	M8	1	Washer	Rondelle	Arandela
14	3019198X1		1	Pin	Axe	Pasador
15	390972X1	M8	1	Washer	Rondelle	Arandela
16	1442864X1		1	Pin, Split	Goupille	Pasador
17	3521747Z6		1	Latching Device	Verrou	Cerrojo
18	3521783M2	dia 30 mm	2	Pin	Axe	Pasador
19	392758X1		4	Ring, Snap	Anneau d'arrêt	Anillo de resorte



820 860 880 970 980
 TX760B TX860B

805 806 807 808 817 825 833 834 845 855 921 931

69001C01.1

6199042M3

1

Jan-06

Boom Transport Lock
Verrouillage de Transport de Flèche
Bloqueo de transporte de pluma

Centre mounted digger
 Montage de pelle central
 Excavadora de montaje central

C-69002-01.1-A

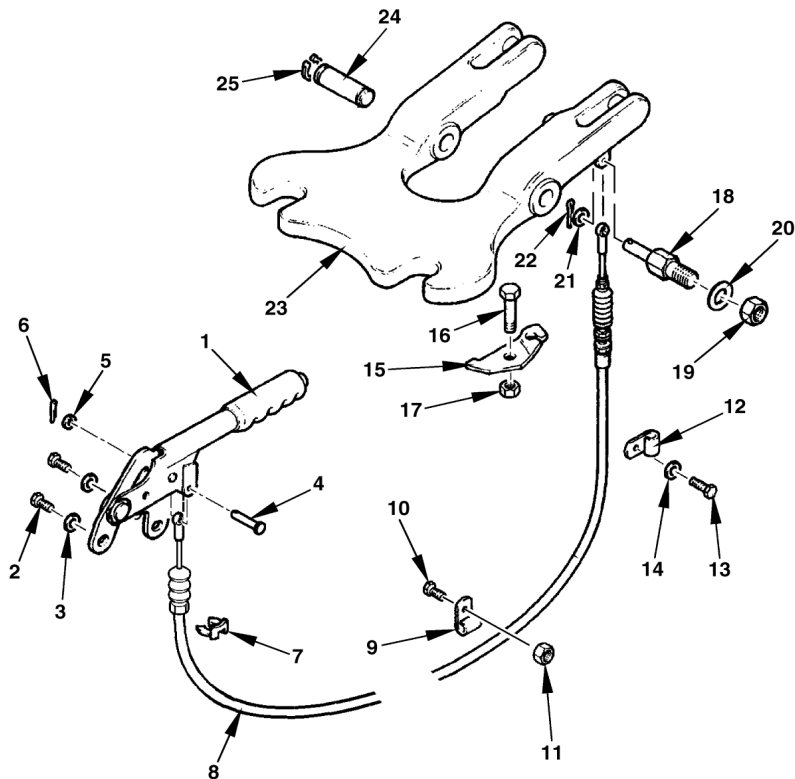

1	3522379M92		1	Lever, Control	Levier de commande	Palanca de mando
2	339124X1	M8 x 16	2	Screw	Vis	Tornillo
3	390972X1	M8	2	Washer	Rondelle	Arandela
4	3019192X1	dia 6	1	Pin	Axe	Pasador
5	390971X1	M6	1	Washer	Rondelle	Arandela
6	1442864X1		1	Pin, Split	Goupille	Pasador
7	3522777M1		1	Clip	Clip	Clip
8	6106282M91		1	Cable Assy	Ensemble de câble	Cable, Conj.
9	3517114M2		1	Clip, Mounting	Collier de fixation	Argolla de fijación
10	339337X1	M8 x 30	1	Bolt	Boulon	Perno
11	394367X1	M8	1	Nut, Lock	Écrou de blocage	Tuerca de retención
12	3517114M2		1	Clip, Mounting	Collier de fixation	Argolla de fijación
13	339124X1	M8 x 16	1	Screw	Vis	Tornillo
14	390972X1	M8	1	Washer	Rondelle	Arandela
15	3517697M2		1	Anchor	Ancre	Ancla
16	3516013M1	M10 x 40	1	Screw	Vis	Tornillo
17	1440329X1	M10	1	Nut, Lock	Écrou de blocage	Tuerca de retención
18	3517698M2		1	Pin	Axe	Pasador
19	339169X1	M8	1	Nut	Écrou	Tuerca
20	339374X1	M8	1	Washer, Lock	Rondelle de blocage	Arandela de freno
21	390971X1	M6	1	Washer	Rondelle	Arandela
22	1442864X1		1	Pin, Split	Goupille	Pasador
23	3521747M6		1	Latching Device	Verrou	Cerrojo
24	3521783M2	dia 30 mm	2	Pin	Axe	Pasador
25	392758X1		4	Ring, Snap	Anneau d'arrêt	Anillo de resorte



820 860 880 970 980
 TX760B TX860B
 TX870B TX970B

801 802 803 804 809 810 811 812 813 814 815 816 821 822 823 824 831 832 841
 842 843 844 851 852 853 854 922 923 932

69002C01.1

6199042M3

1

Jan-06

Digger Bucket Linkage
Articulations Godet de Défonceuse
Articulaciones de cuchara retro

AC-74001-01.1-A

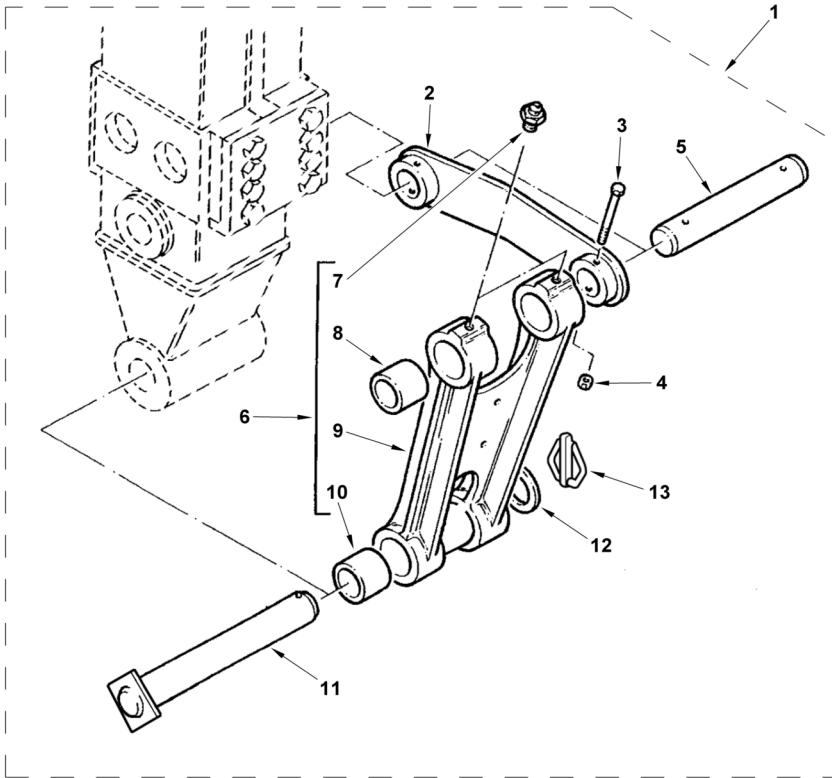

1	ACC15A		Continued Std Dipper & Linkage	1	Accessory code	Code accessoire	Código accesorio
2	3500023M91	1		2	Link Assy	Ensemble de maillon	Eslabón, Conj.
3	1441106X1	1	M10 x 100	4	Screw	Vis	Tornillo
4	1440329X1	1	M10	4	Nut, Lock	Écrou de blocage	Tuerca de retención
5	3522696M2	1	45 x 307 mm	2	Pin	Axe	Pasador
6	3522442M92	1		1	Link Assy	Ensemble de maillon	Eslabón, Conj.
7	339608X1	6		3	Fitting, Grease	Graisseur	Engrasador
8	3500009M3	6		2	Bushing	Bague	Anillo
9		6	➡ Ref. 6	1	Link	Maillon	Eslabón
10	3500009M3	6		2	Bushing	Bague	Anillo
11	3516519M94	1	45 x 302 mm	2	Pin	Axe	Pasador
12	3501790M1	1		2	Washer	Rondelle	Arandela
13	3516522M91	1		2	Pin, Linch	Goupille d'arrêt	Pasador de parada



820 860 880 970 980
 TX760B TX860B
 TX870B TX970B

801 802 803 804 805 806 807 808 809 810 811 812 813 814 815 816 817 821 822
 823 824 825 831 832 833 834 841 842 843 844 845 851 852 853 854 855 921 922
 923 931 932

74001AC01.1

6199042M3

1

Jan-06

Digger Bucket Linkage
Articulations Godet de Défonceuse
Articulaciones de cuchara retro

C-74001-01.1-A

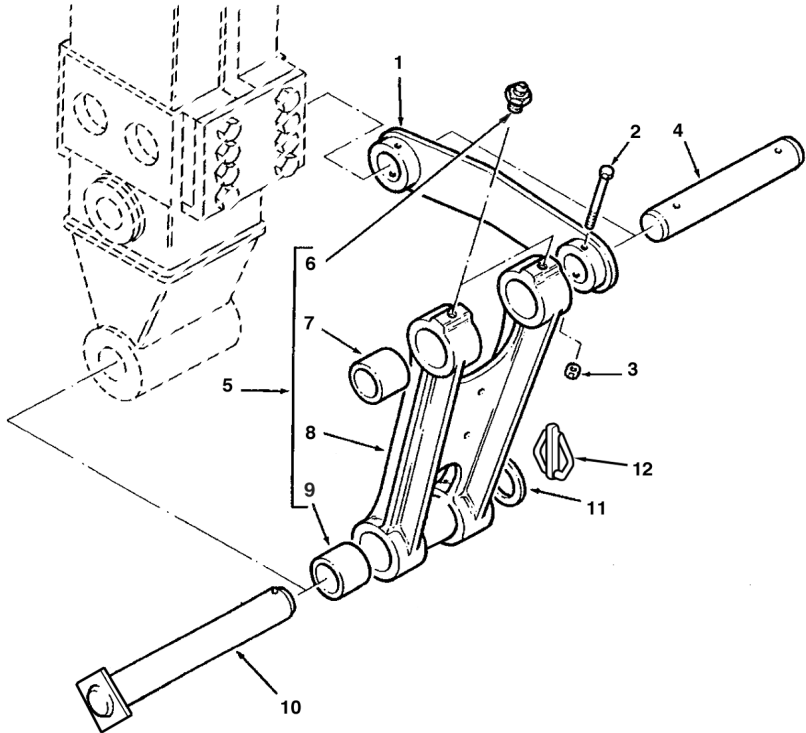

1	3500023M91		2	Link Assy	Ensemble de maillon	Eslabón, Conj.
2	1441106X1	M10 x 100	4	Screw	Vis	Tornillo
3	1440329X1	M10	4	Nut, Lock	Écrou de blocage	Tuerca de retención
4	3522696M2	45 x 307 mm	2	Pin	Axe	Pasador
5	3522442M92		1	Link Assy	Ensemble de maillon	Eslabón, Conj.
6	339608X1	5	3	Fitting, Grease	Graisseur	Engrasador
7	3500009M3	5	2	Bushing	Bague	Anillo
8		5  Ref. 5	1	Link	Maillon	Eslabón
9	3500009M3	5	2	Bushing	Bague	Anillo
10	3516519M94	45 x 302 mm	2	Pin	Axe	Pasador
11	3501790M1		2	Washer	Rondelle	Arandela
12	3516522M91		2	Pin, Linch	Goupille d'arrêt	Pasador de parada



820 860 880 970 980
 TX760B TX860B
 TX870B TX970B

801 802 803 804 805 806 807 808 809 810 811 812 813 814 815 816 817 821 822
 823 824 825 831 832 833 834 841 842 843 844 845 851 852 853 854 855 921 922
 923 931 932

74001C01.1

6199042M3

1

Jan-06

Digger Bucket Linkage
Articulations Godet de Défonceuse
Articulaciones de cuchara retro

Case Buckets
Godets Case
Cucharas case

AC-74003-01.1-A

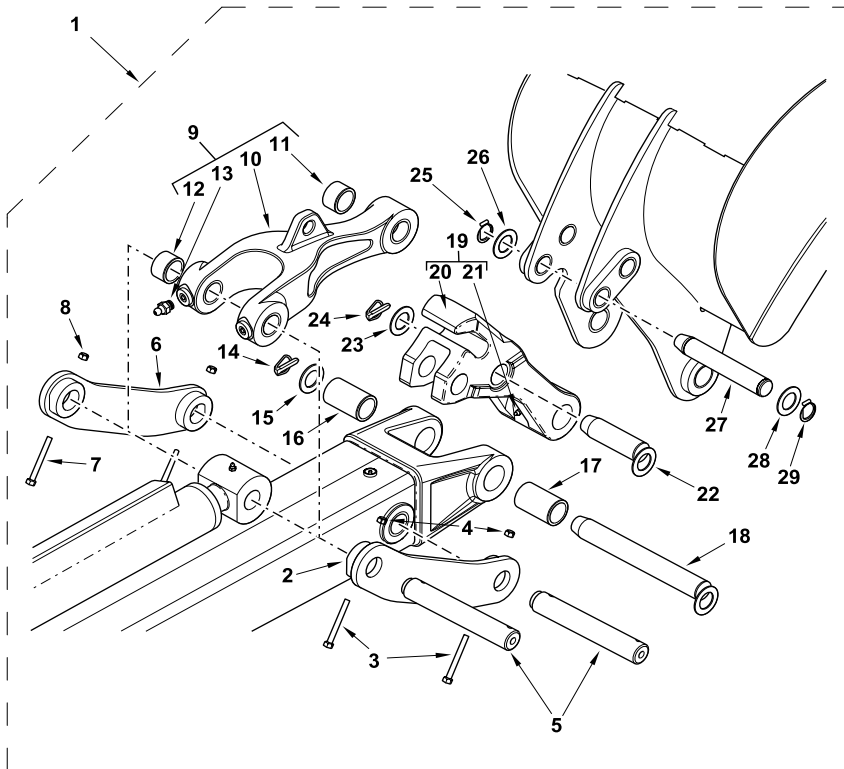

1	ACC16A	Continued Case Dipper & Linkage	1	Accessory code	Code accessoire	Código accesorio
2	6100171M91	1	1	Link Assy	Ensemble de maillon	Eslabón, Conj.
3	1441106X1	1 M10 x 100	2	Screw	Vis	Tornillo
4	1440329X1	1 M10	2	Nut, Lock	Écrou de blocage	Tuerca de retención
5	3522696M2	1 45 x 307 mm	2	Pin	Axe	Pasador
6	6100171M91	1	1	Link Assy	Ensemble de maillon	Eslabón, Conj.
7	1441106X1	1 M10 x 100	2	Screw	Vis	Tornillo
8	1440329X1	1 M10	2	Nut, Lock	Écrou de blocage	Tuerca de retención
9	6100167M92	1	1	Link Assy	Ensemble de maillon	Eslabón, Conj.
10		9	1	Link	Maillon	Eslabón
11	D127172	9	1	Bushing	Bague	Anillo
12	3500009M3	9	2	Bushing	Bague	Anillo
13	339608X1	9	3	Fitting, Grease	Graisseur	Engrasador
14	392181R1	1	1	Pin, Linch	Goupille d'arrêt	Pasador de parada
15	3501790M1	1	1	Washer	Rondelle	Arandela
16	D127168	1	1	Bushing	Bague	Anillo
17	D127168	1	1	Bushing	Bague	Anillo
18	D140655	1 44 x 349 mm	1	Pin Assy	Ensemble d'axe	Pasador, Conj.
19	6101312M91	1	1	Link, Connecting	Maillon de raccord	Eslabón de conexión
20		19	1	Link	Maillon	Eslabón
21	219-1	19	1	Fitting, Grease	Graisseur	Engrasador
22	D140653	1 44 x 152 mm	1	Pin Assy	Ensemble d'axe	Pasador, Conj.
23	3501790M1	1	1	Washer	Rondelle	Arandela
24	392181R1	1	1	Pin, Linch	Goupille d'arrêt	Pasador de parada
25	D25279	1	1	Circlip	Segment d'arrêt	Circlip
26	D143324	1	1	Washer	Rondelle	Arandela
27	D37614	1 1.5" x 9.68"	1	Pin	Axe	Pasador
28	D143324	1	2	Washer	Rondelle	Arandela
29	D25279	1	2	Circlip	Segment d'arrêt	Circlip



820 860 880 970 980
 TX760B TX860B
 TX870B TX970B

801 802 803 804 805 806 807 808 809 810 811 812 813 814 815 816 817 821 822
 823 824 825 831 832 833 834 841 842 843 844 845 851 852 853 854 855 921 922
 923 931 932

74003AC01.1

6199042M3

1

Jan-06

Digger Bucket Linkage
Articulations Godet de Défonceuse
Articulaciones de cuchara retro

Case Buckets
Godets Case
Cucharas case

C-74003-01.1-A

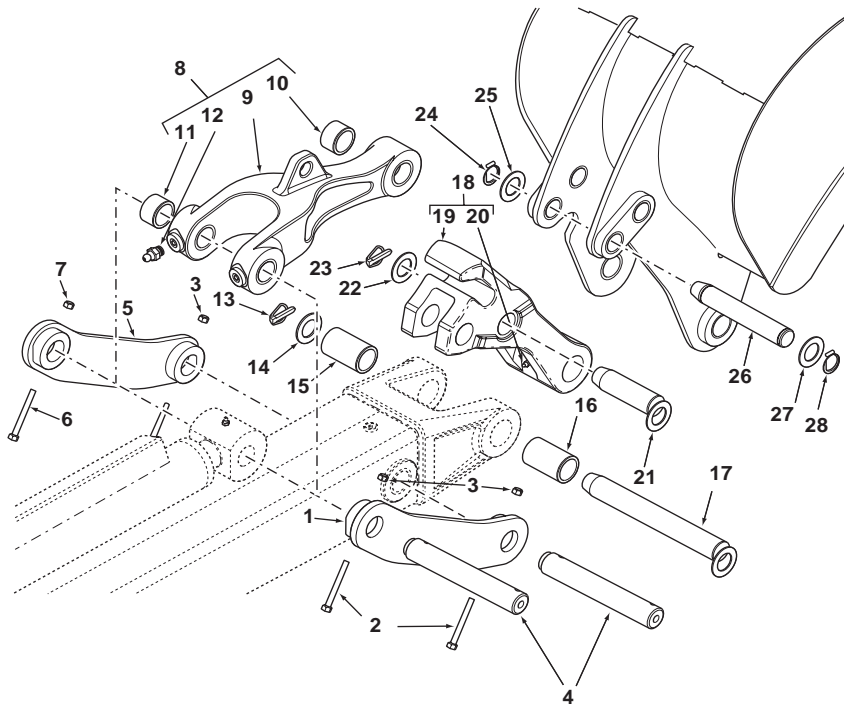

1	6100171M91		1	Link Assy	Ensemble de maillon	Eslabón, Conj.
2	1441106X1	M10 x 100	2	Screw	Vis	Tornillo
3	1440329X1	M10	2	Nut, Lock	Écrou de blocage	Tuerca de retención
4	3522696M2	45 x 307 mm	2	Pin	Axe	Pasador
5	6100171M91		1	Link Assy	Ensemble de maillon	Eslabón, Conj.
6	1441106X1	M10 x 100	2	Screw	Vis	Tornillo
7	1440329X1	M10	2	Nut, Lock	Écrou de blocage	Tuerca de retención
8	6100167M92		1	Link Assy	Ensemble de maillon	Eslabón, Conj.
9		8 Ref. 8	1	Link	Maillon	Eslabón
10	D127172	8	1	Bushing	Bague	Anillo
11	3500009M3	8	2	Bushing	Bague	Anillo
12	339608X1	8	3	Fitting, Grease	Graisser	Engrasador
13	392181R1		1	Pin, Linch	Goupille d'arrêt	Pasador de parada
14	3501790M1		1	Washer	Rondelle	Arandela
15	D127168		1	Bushing	Bague	Anillo
16	D127168		1	Bushing	Bague	Anillo
17	D140655	44 x 349 mm	1	Pin Assy	Ensemble d'axe	Pasador, Conj.
18	6101312M91		1	Link, Connecting	Maillon de raccord	Eslabón de conexión
19		18 Ref. 18	1	Link	Maillon	Eslabón
20	219-1	18	1	Fitting, Grease	Graisser	Engrasador
21	D140653	44 x 152 mm	1	Pin Assy	Ensemble d'axe	Pasador, Conj.
22	3501790M1		1	Washer	Rondelle	Arandela
23	392181R1		1	Pin, Linch	Goupille d'arrêt	Pasador de parada
24	D25279		1	Circlip	Segment d'arrêt	Circlip
25	D143324		1	Washer	Rondelle	Arandela
26	D37614	1.5" x 9.68"	1	Pin	Axe	Pasador
27	D143324		2	Washer	Rondelle	Arandela
28	D25279		2	Circlip	Segment d'arrêt	Circlip



820 860 880 970 980
 TX760B TX860B
 TX870B TX970B

801 802 803 804 805 806 807 808 809 810 811 812 813 814 815 816 817 821 822
 823 824 825 831 832 833 834 841 842 843 844 845 851 852 853 854 855 921 922
 923 931 932

74003C01.1

6199042M3

1

Jan-06

Digger Bucket Linkage
Articulations Godet de Défonceuse
Articulaciones de cuchara retro

JCB Buckets
Godets JCB
Cucharas JCB

C-74002-01.1-A

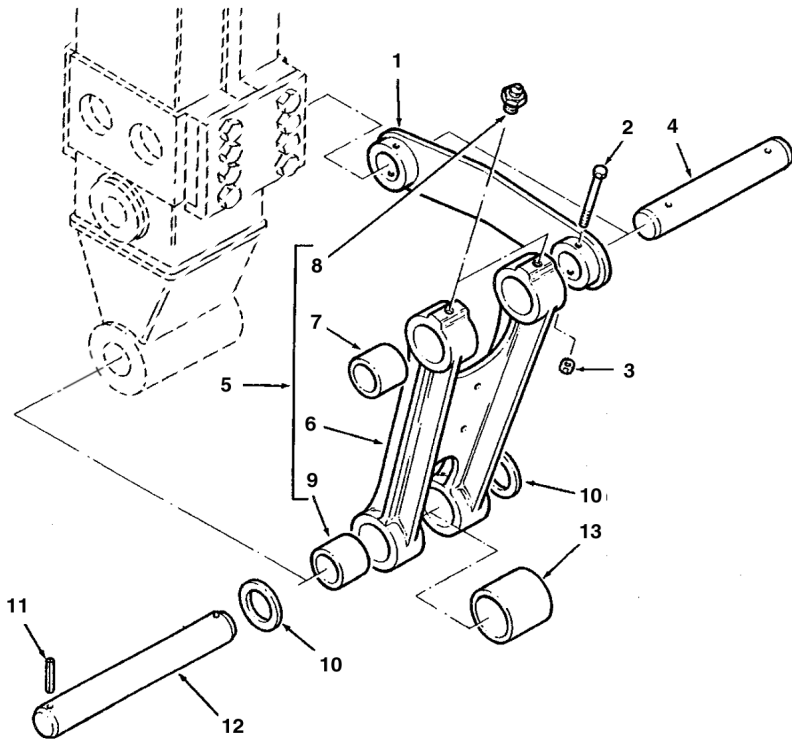

1	3500023M91		2	Link Assy	Ensemble de maillon	Eslabón, Conj.
2	1441106X1	M10 x 100	4	Screw	Vis	Tornillo
3	1440329X1	M10	4	Nut, Lock	Écrou de blocage	Tuerca de retención
4	3522696M2	45 x 307 mm	2	Pin	Axe	Pasador
5	3508449M92		1	Link Assy	Ensemble de maillon	Eslabón, Conj.
6		5 Ref.5	1	Link	Maillon	Eslabón
7	3500009M3	5	2	Bushing	Bague	Anillo
8	339608X1	5	4	Fitting, Grease	Graisseur	Engrasador
9	6106532M1	5	2	Bushing	Bague	Anillo
10	3501790M1		4	Washer	Rondelle	Arandela
11	375096X1		4	Pin, Linch	Goupille d'arrêt	Pasador de parada
12	6106549M1	45 x 364 mm	2	Pin	Axe	Pasador
13	3508456M1		1	Spacer	Entretoise	Traviesa



820 860 880 970 980
 TX760B TX860B
 TX870B TX970B

801 802 803 804 805 806 807 808 813 814 815 816 817 821 822 823 824 825 831
 832 833 834 841 842 843 844 845 851 852 853 854 855 921 922 923 931 932

74002C01.1

6199042M3

1

Jan-06

Digger Controls
Commandes Défonceuse
Mandos de equipo retro

Standard
 Standard
 Estándar

C-77001-01.1-A

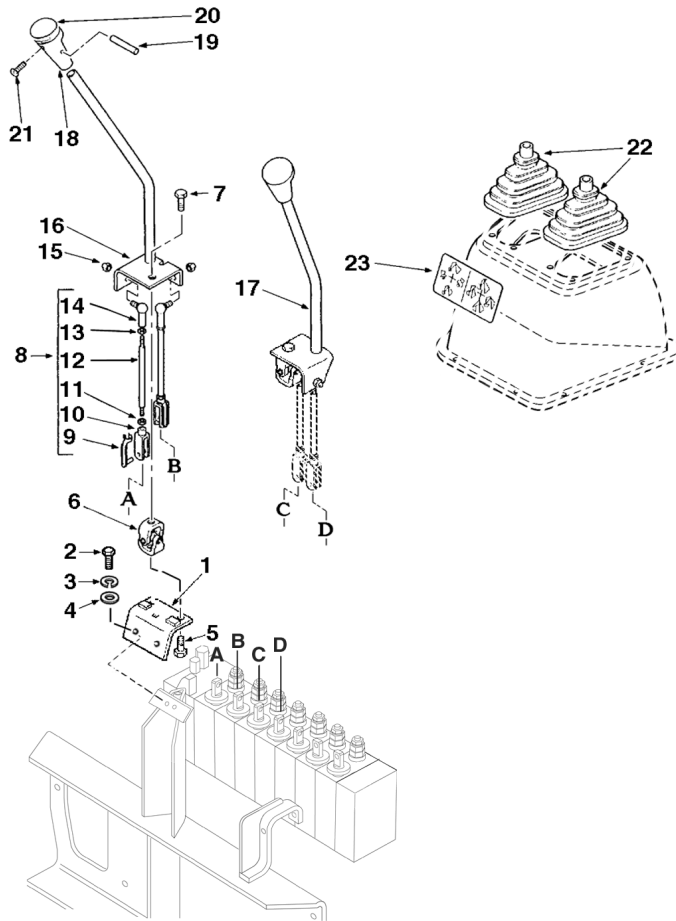

1	6106682M91		1	Support Assy	Ensemble de support	Apoyadero, Conj.
2	339124X1	M8 x 16	3	Screw	Vis	Tornillo
3	339374X1	M8	3	Washer, Lock	Rondelle de blocage	Arandela de freno
4	390972X1	M8	3	Washer	Rondelle	Arandela
5	354742X1	1/2" x 5/8"	2	Bolt	Boulon	Perno
6	3521075M91		2	Joint, Universal	Cardan	Cardán
7	354742X1	1/2" x 5/8"	2	Bolt	Boulon	Perno
8	6106905M91		4	Rod Assy	Ensemble tringlerie	Tirantes, Conj.
9	3520666M1	8	1	Pin, Clevis	Axe de chape	Eje de brida
10	3519590M1	8 LH Thread	1	Clevis	Chape	Brida
11	3519650M1	8 ◀ M8 LH Thread	1	Nut	Écrou	Tuerca
12		8 ▶ Ref. 8	1	Rod	Tringle	Vástago
13	339169X1	8 M8	1	Nut	Écrou	Tuerca
14	3517518M1	8	1	Ball Joint	Rotule	Rotula
15	394367X1	M8	4	Nut, Lock	Écrou de blocage	Tuerca de retención
16	6107130M91	▶	1	Lever Assy	Ensemble de levier	Palanca, Conj.
17	6107131M91	◀	1	Lever Assy	Ensemble de levier	Palanca, Conj.
18	3522621M5		2	Grip	Poignée de levier	Empuñ. Palanca
19	3019531X1		2	Pin, Roll	Goupille élastique	Pasador elástico
20	3522669M3		2	Cap	Chapeau	Sombbrero
21	3516886M1		4	Screw	Vis	Tornillo
22	6109905M1		2	Boot	Soufflet	Fuelle
23	6101890M1		1	Decal	Adhésif	Adhesivo



820 860 970
 TX760B TX860B
 TX870B

801 802 803 804 805 806 807 808 809 810 811 812 813 814 815 816 817 821 822
 823 824 825 921 922 923

77001C01.1

6199042M3

1

Jan-06

Digger Controls
Commandes Défonceuse
Mandos de equipo retro

ISO
 ISO
 Iso

C-77002-01.1-A

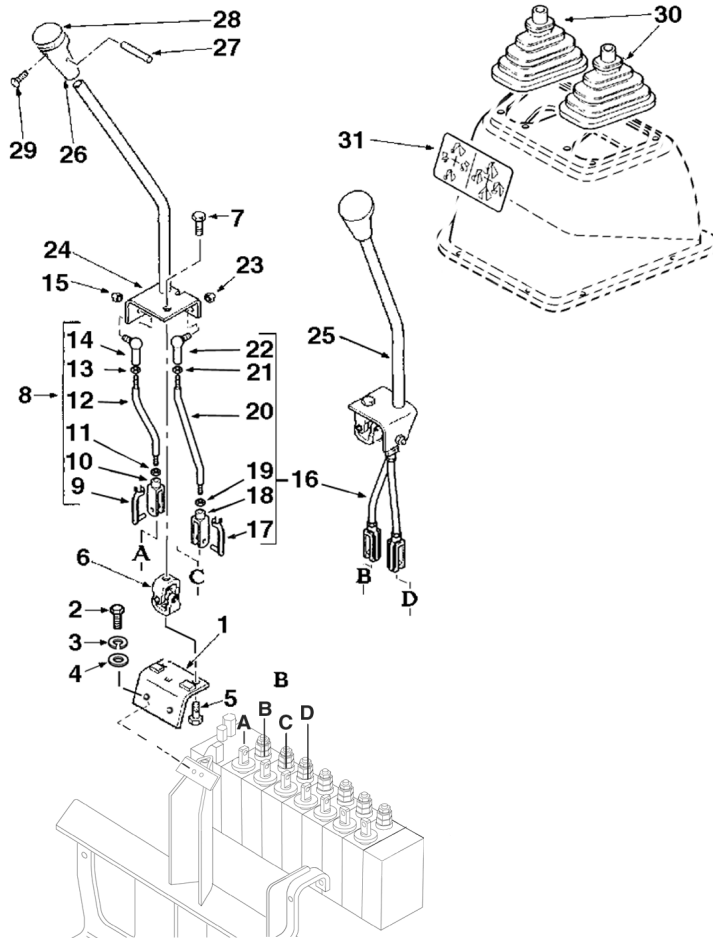

1	6106682M91		1	Support Assy	Ensemble de support	Apoyadero, Conj.
2	339124X1	M8 x 16	3	Screw	Vis	Tornillo
3	339374X1	M8	3	Washer, Lock	Rondelle de blocage	Arandela de freno
4	390972X1	M8	3	Washer	Rondelle	Arandela
5	354742X1	1/2" x 5/8"	2	Bolt	Boulon	Perno
6	3521075M91		2	Joint, Universal	Cardan	Cardán
7	354742X1	1/2" x 5/8"	2	Bolt	Boulon	Perno
8	6106905M91		2	Rod Assy	Ensemble tringlerie	Tirantes, Conj.
9	3520666M1	8	1	Pin, Clevis	Axe de chape	Eje de brida
10	3519590M1	8 LH Thread	1	Clevis	Chape	Brida
11	3519650M1	8 ◀ M8 LH Thread	1	Nut	Écrou	Tuerca
12		8 ▶ Ref. 8	1	Rod	Tringle	Vástago
13	339169X1	8 M8	1	Nut	Écrou	Tuerca
14	3517518M1	8	1	Ball Joint	Rotule	Rotula
15	394367X1	M8	2	Nut, Lock	Écrou de blocage	Tuerca de retención
16	6107371M91		2	Rod Assy	Ensemble tringlerie	Tirantes, Conj.
17	3520666M1	16	1	Pin, Clevis	Axe de chape	Eje de brida
18	3519590M1	16 LH Thread	1	Clevis	Chape	Brida
19	3519650M1	16 ◀ M8 LH Thread	1	Nut	Écrou	Tuerca
20		16 ▶ Ref. 16	1	Rod	Tringle	Vástago
21	339169X1	16 M8	1	Nut	Écrou	Tuerca
22	3517518M1	16	1	Ball Joint	Rotule	Rotula
23	394367X1	M8	2	Nut, Lock	Écrou de blocage	Tuerca de retención
24	6107130M91	▶	1	Lever Assy	Ensemble de levier	Palanca, Conj.
25	6107131M91	◀	1	Lever Assy	Ensemble de levier	Palanca, Conj.
26	3522621M5		2	Grip	Poignée de levier	Empuñ. Palanca
27	3019531X1		2	Pin, Roll	Goupille élastique	Pasador elástico
28	3522669M3		2	Cap	Chapeau	Sombbrero
29	3516886M1		4	Screw	Vis	Tornillo
30	6109905M1		2	Boot	Soufflet	Fuelle
31	6101895M1		1	Decal	Adhésif	Adhesivo



820 860 970
 TX760B TX860B
 TX870B

801 802 803 804 805 806 807 808 809 810 811 812 813 814 815 816 817 821 822
 823 824 825 921 922 923

77002C01.1

6199042M3

1

Jan-06

Digger Controls
Commandes Défonceuse
Mandos de equipo retro

X Pattern
 Motif En "X"
 Patrón "X"

C-77003-01.1-A

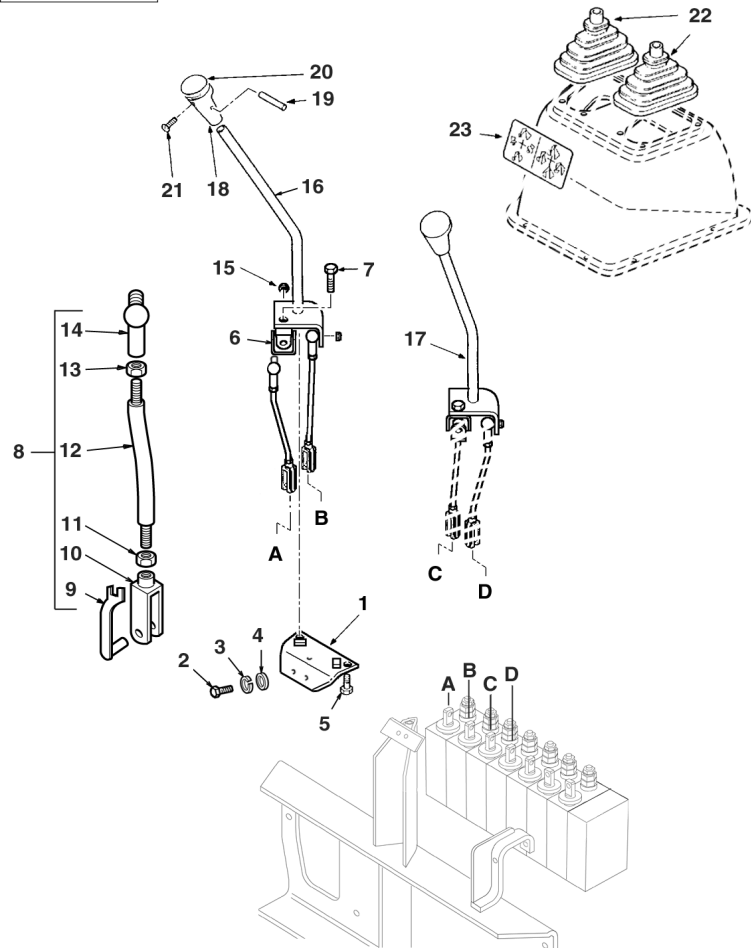

1	6106958M91		1	Bracket	Patte de fixation	Pata de fijación
2	339124X1	M8 x 16	3	Screw	Vis	Tornillo
3	339374X1	M8	3	Washer, Lock	Rondelle de blocage	Arandela de freno
4	390972X1	M8	3	Washer	Rondelle	Arandela
5	354742X1	1/2" x 5/8"	2	Bolt	Boulon	Perno
6	3521075M91		2	Joint, Universal	Cardan	Cardán
7	354742X1	1/2" x 5/8"	2	Bolt	Boulon	Perno
8	6106905M91		4	Rod Assy	Ensemble tringlerie	Tirantes, Conj.
9	3520666M1	8	1	Pin, Clevis	Axe de chape	Eje de brida
10	3519590M1	8 LH Thread	1	Clevis	Chape	Brida
11	3519650M1	8 ◀ M8 LH Thread	1	Nut	Écrou	Tuerca
12		8 ▶ Ref. 8	1	Rod	Tringle	Vástago
13	339169X1	8 M8	1	Nut	Écrou	Tuerca
14	3517518M1	8	1	Ball Joint	Rotule	Rotula
15	394367X1	M8	4	Nut, Lock	Écrou de blocage	Tuerca de retención
16	6107172M91	◀	1	Lever Assy	Ensemble de levier	Palanca, Conj.
17	6107173M91	▶	1	Lever Assy	Ensemble de levier	Palanca, Conj.
18	3522621M5		2	Grip	Poignée de levier	Empuñ. Palanca
19	3019531X1		2	Pin, Roll	Goupille élastique	Pasador elástico
20	3522669M3		2	Cap	Chapeau	Sombbrero
21	3516886M1		4	Screw	Vis	Tornillo
22	6109905M1		2	Boot	Soufflet	Fuelle
23	6101894M1		1	Decal	Adhésif	Adhesivo



820 860 970
 TX760B TX860B

805 806 807 808 817 825 921

77003C01.1

6199042M3

1

Jan-06

Digger Controls
Commandes Défonceuse
Mandos de equipo retro

Servo
Servo
Servo

Pivot
 Pivot
 Pivote

C-77007-01.1-A

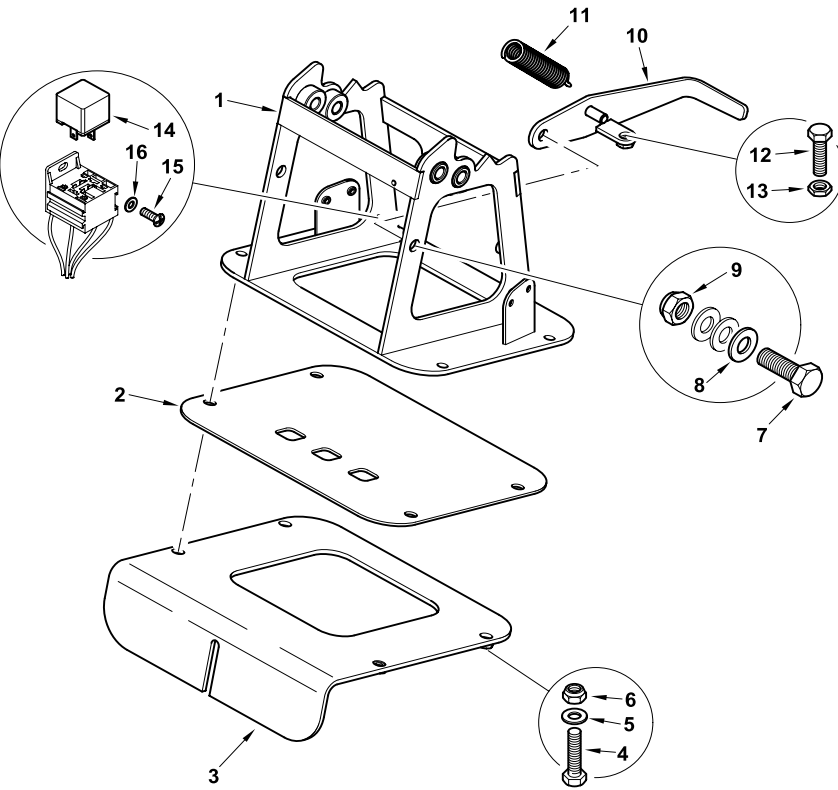

1	6110780M91		1	Pivot Assy	Ensemble de pivot	Pivote, Conj.
2	6110859M1	Rubber	1	Gasket	Joint	Empaquetadura
3	6110809M91		1	Plate, Base	Plaque de base	Placa de base
4	339009X1	M8 x 35	4	Screw	Vis	Tornillo
5	390972X1	M8	4	Washer	Rondelle	Arandela
6	394367X1	M8	4	Nut, Lock	Écrou de blocage	Tuerca de retención
7	3009507X1	M12 x 35	1	Bolt	Boulon	Perno
8	390735X1	M12	3	Washer	Rondelle	Arandela
9	1442190X1	M12	1	Nut, Lock	Écrou de blocage	Tuerca de retención
10	6110776M91		1	Pedal Assy	Ensemble de pédale	Pedal, Conj.
11	6110893M1		1	Spring	Ressort	Muelle
12	339337X1	M8 x 30	1	Bolt	Boulon	Perno
13	339169X1	M8	1	Nut	Écrou	Tuerca
14	6110473M1	Mini	1	Relay	Relais	Relé
15	3512552M1	M5 x 12	1	Screw	Vis	Tornillo
16	3512553M1	M5	1	Washer	Rondelle	Arandela



880 980
 TX760B TX860B
 TX870B TX970B

831 832 833 841 842 843 845 851 852 853 855 931 932

77007C01.1

6199042M3

1

Jan-06

Digger Controls
Commandes Défonceuse
Mandos de equipo retro

Servo
Servo
Servo

Control Bar
Commandez la barre
Control bar

C-77007-02.1-A

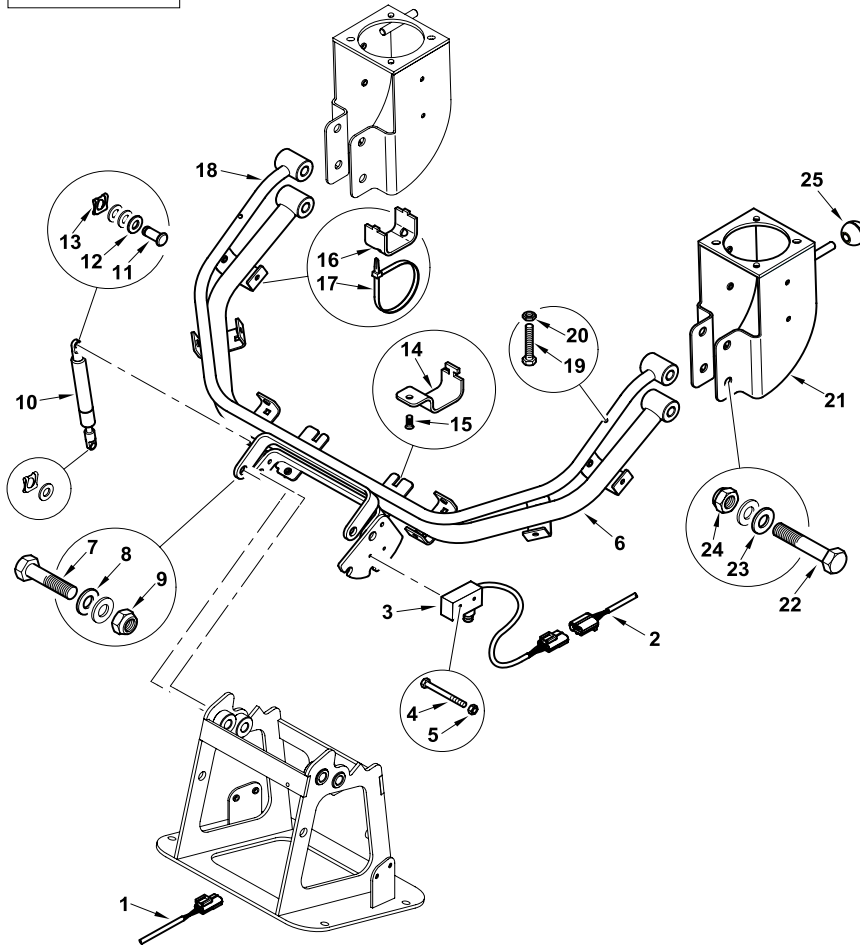

1	6110886M92	Supplementary Chassis	1	Harness Assy	Ensemble de faisceau	Haz, Conj.
2	6110885M92	Yolk	1	Harness Assy	Ensemble de faisceau	Haz, Conj.
3	6110884M91		1	Switch Assy	Ensemble commutat.	Conmutador, Conj.
4	6110887M1	M3 Special	2	Bolt	Boulon	Perno
5	391216X1	M3	2	Nut	Écrou	Tuerca
6	6110765M91		1	Bar	Barre	Barra
7	6110850M1	M12 x 50 Special	4	Bolt	Boulon	Perno
8	390735X1	M12	8	Washer	Rondelle	Arandela
9	1442190X1	M12	4	Nut, Lock	Écrou de blocage	Tuerca de retención
10	6110849M91		1	Gas Strut	Vérin à gaz	Gato de gas
11	6102816M1		1	Pin, Clevis	Axe de chape	Eje de brida
12	390972X1	M8	5	Washer	Rondelle	Arandela
13	3516322M1		2	Clip	Clip	Clip
14	6110890M1		2	Clamp	Collier de serrage	Argolla de cierre
15	3512552M1	M5 x 12	2	Screw	Vis	Tornillo
16	6110785M1		6	Clamp	Collier de serrage	Argolla de cierre
17	1876229M1		6	Tie, Cable	Attache câble	Enlace de Cable
18	6110770M91		1	Bar	Barre	Barra
19	339351X1	M6 x 25	2	Screw	Vis	Tornillo
20	391255X1	M6	2	Nut	Écrou	Tuerca
21	6110873M91	LH Joystick	1	Bracket Assy	Ensemble chaise palier	Cuchara, Conj.
21	6110808M91	RH Joystick	1	Bracket Assy	Ensemble chaise palier	Cuchara, Conj.
22	6110851M1	M12 x 65 Special	4	Bolt	Boulon	Perno
23	390735X1	M12	8	Washer	Rondelle	Arandela
24	1442190X1	M12	4	Nut, Lock	Écrou de blocage	Tuerca de retención
25	3517899M1		2	Knob	Boule	Bola



880 980
 TX760B TX860B
 TX870B TX970B

831 832 833 841 842 843 845 851 852 853 855 931 932

77007C02.1

6199042M3

1

Jan-06

Digger Controls
Commandes Défonceuse
Mandos de equipo retro

Servo
Servo
Servo

Pilot Control
 Asservissement
 Control pilotaje

C-77007-03.1-B

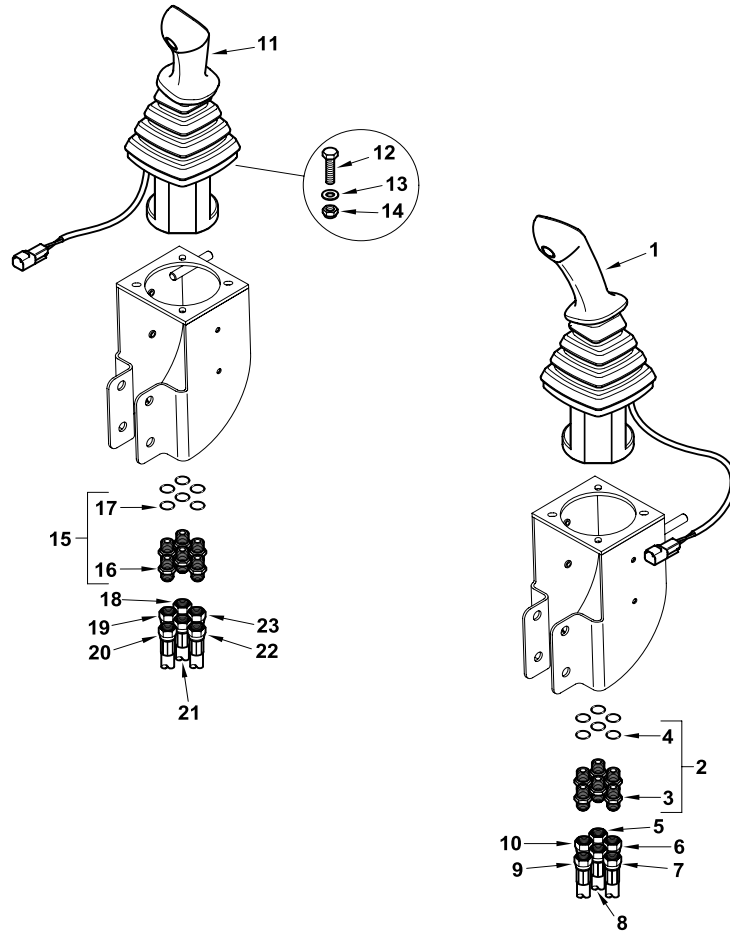

1	6110915M91	LH	1	Joystick	Manche	Palanca de mando
2	835091M91	9/16	6	Union	Union	Unión
3		2 Ref. 2	1	Union	Union	Unión
4	831452M1	2	1	O-Ring	Joint torique	Junta de tipo O
5	6110909M91	Tank 1900mm	1	Hose Assy	Ensemble de flexible	Flexible, Conj.
6	6110901M91	[77007C05.1 20] Boom (Orange) 1100mm	1	Hose Assy	Ensemble de flexible	Flexible, Conj.
7	6110904M91	Slew (Green) 1150mm	1	Hose Assy	Ensemble de flexible	Flexible, Conj.
8	6110907M91	Pressure (Grey) 2050mm	1	Hose Assy	Ensemble de flexible	Flexible, Conj.
9	6110896M91	[77007C05.1 33] Boom (Blue) 1000mm	1	Hose Assy	Ensemble de flexible	Flexible, Conj.
10	6110906M91	Slew (Purple) 1250mm	1	Hose Assy	Ensemble de flexible	Flexible, Conj.
11	6110916M91	RH	1	Joystick	Manche	Palanca de mando
12	339351X1	M6 x 25	8	Screw	Vis	Tornillo
13	390971X1	M6	16	Washer	Rondelle	Arandela
14	1441500X1	M6	8	Nut, Lock	Écrou de blocage	Tuerca de retención
15	835091M91	9/16	6	Union	Union	Unión
16		15 Ref. 15	1	Union	Union	Unión
17	831452M1	15	1	O-Ring	Joint torique	Junta de tipo O
18	6110910M91	Tank 2000mm	1	Hose Assy	Ensemble de flexible	Flexible, Conj.
19	6110903M91	Bucket (Brown) 1150mm	1	Hose Assy	Ensemble de flexible	Flexible, Conj.
20	6110898M91	[77007C05 24] Dipper (Red) 950mm	1	Hose Assy	Ensemble de flexible	Flexible, Conj.
21	6110908M91	Pressure (Grey) 1700mm	1	Hose Assy	Ensemble de flexible	Flexible, Conj.
22	6110905M91	Bucket (White) 1250mm	1	Hose Assy	Ensemble de flexible	Flexible, Conj.
22	6110899M91	[77007C05.1 38] Dipper (Yellow) 1050mm	1	Hose Assy	Ensemble de flexible	Flexible, Conj.



880 980
 TX760B TX860B
 TX870B TX970B

831 832 833 841 842 843 845 851 852 853 855 931 932

77007C03.1

6199042M3

1

Jan-06

Digger Controls
Commandes Défonceuse
Mandos de equipo retro

Servo
Servo
Servo

Trim
 Finition
 Ajuste

C-77007-04.1-B

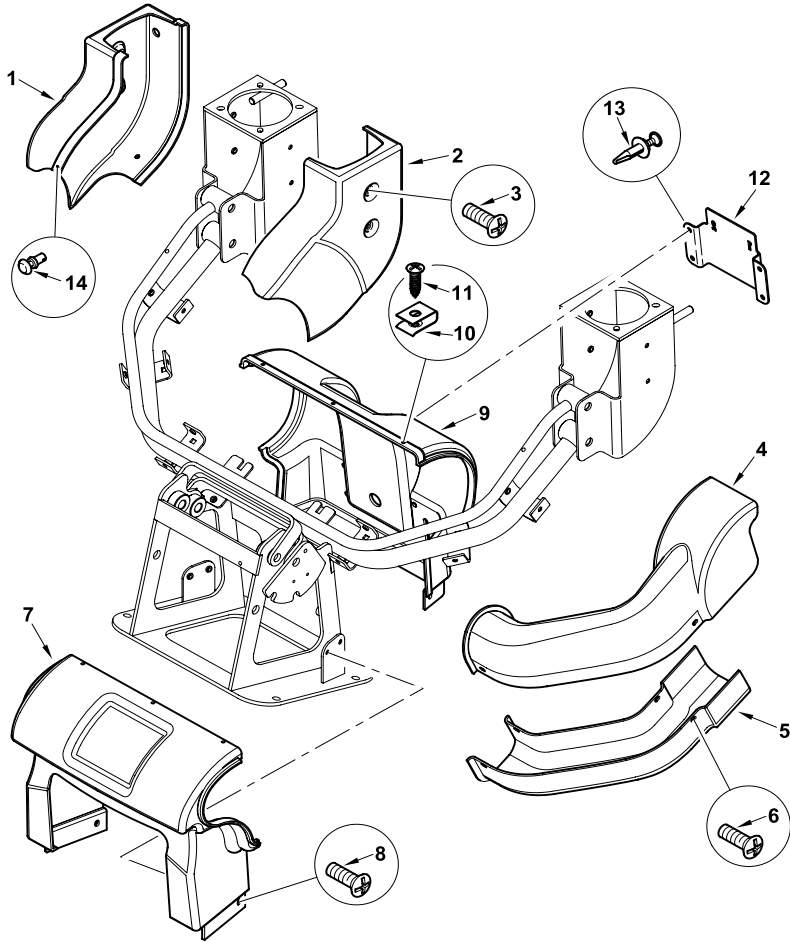

1	6110871M1	LH	1	Cover	Cache	Tapa
1	6110800M1	RH	1	Cover	Cache	Tapa
2	6110872M1	LH	1	Cover	Cache	Tapa
2	6110801M1	RH	1	Cover	Cache	Tapa
3	3512552M1	M5 x 12	12	Screw	Vis	Tornillo
4	6110804M1	LH	1	Cover	Cache	Tapa
4	6110805M1	RH	1	Cover	Cache	Tapa
5	6110802M1	LH	1	Cover	Cache	Tapa
5	6110803M1	RH	1	Cover	Cache	Tapa
6	3512552M1	M5 x 12	8	Screw	Vis	Tornillo
7	6110807M1	Rear	1	Cover	Cache	Tapa
8	3512552M1	M5 x 12	4	Screw	Vis	Tornillo
9	6110806M1	Front	1	Cover	Cache	Tapa
10	6110888M1		3	Nut, U	Écrou en U	Tuerca en U
11	6110889M1		3	Screw	Vis	Tornillo
12	6110952M1		1	Plate, Cover	Plaque de fermeture	Placa de cierre
13	6101591M1	Plastic	4	Rivet	Rivet	Remache
14	6111193M1	Plastic	2	Rivet	Rivet	Remache



880 980
 TX760B TX860B
 TX870B TX970B

831 832 833 841 842 843 845 851 852 853 855 931 932

77007C04.1

6199042M3

1

Jan-06

Digger Controls
Commandes Défonceuse
Mandos de equipo retro

Servo
Servo
Servo

Change over valve
 Valve de changement
 Válvula de cambio

C-77007-05.1-A

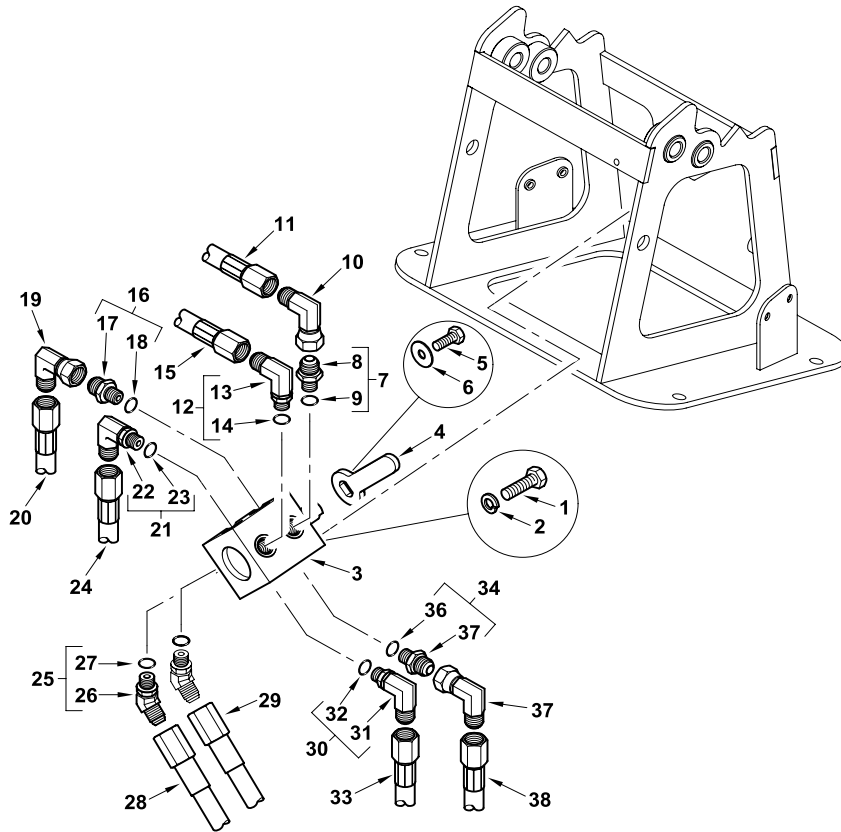

1	339666X1	M6 x 20	2	Screw	Vis	Tornillo
2	339375X1	M6	2	Washer, Lock	Rondelle de blocage	Arandela de freno
3	6110813M1		1	Valve, Control	Distributeur	Distribuidor
4	6110853M1		1	Lever	Levier	Palanca
5	339560X1	M6 x 16	1	Screw	Vis	Tornillo
6	391038X1	M6	1	Washer	Rondelle	Arandela
7	367407X91		1	Connector Assy	Ensemble connexion	Conexión, Conj.
8		7	1	Connector	Connecteur	Conector
9	831452M1	7	1	O-Ring	Joint torique	Junta de tipo O
10	364603X1	9/16	1	Elbow, 90°	Coude à 90°	Codo, 90°
11	6110902M91	Boom (Orange) 640mm	1	Hose Assy	Ensemble de flexible	Flexible, Conj.
12	373739X91		1	Elbow, 90°	Coude à 90°	Codo, 90°
13		12	1	Elbow	Coude	Codo
14	831452M1	12	1	O-Ring	Joint torique	Junta de tipo O
15	6110897M91	Dipper (Red) 470mm	1	Hose Assy	Ensemble de flexible	Flexible, Conj.
16	367407X91		1	Connector Assy	Ensemble connexion	Conexión, Conj.
17		16	1	Connector	Connecteur	Conector
18	831452M1	16	1	O-Ring	Joint torique	Junta de tipo O
19	364603X1	9/16	1	Elbow, 90°	Coude à 90°	Codo, 90°
20		Boom [77007C03.1 6]	1	Hose Assy	Ensemble de flexible	Flexible, Conj.
21	373739X91		1	Elbow, 90°	Coude à 90°	Codo, 90°
22		21	1	Elbow	Coude	Codo
23	831452M1	21	1	O-Ring	Joint torique	Junta de tipo O
24		Dipper [77007C03.1 19]	1	Hose Assy	Ensemble de flexible	Flexible, Conj.
25	6110919M91		2	Elbow, 45°	Coude à 45°	Codo, 45°
26		25	1	Elbow	Coude	Codo
27	831495M1	25	1	O-Ring	Joint torique	Junta de tipo O
28	6110895M91	Boom (Blue) 350mm	1	Hose Assy	Ensemble de flexible	Flexible, Conj.
29	6110900M91	Dipper (Yellow) 400mm	1	Hose Assy	Ensemble de flexible	Flexible, Conj.
30	373739X91		1	Elbow, 90°	Coude à 90°	Codo, 90°
31		30	1	Elbow	Coude	Codo
32	831452M1	30	1	O-Ring	Joint torique	Junta de tipo O
33		Boom [77007C03.1 9]	1	Hose Assy	Ensemble de flexible	Flexible, Conj.
34	367407X91		1	Connector Assy	Ensemble connexion	Conexión, Conj.
35		34	1	Connector	Connecteur	Conector
36	831452M1	34	1	O-Ring	Joint torique	Junta de tipo O
37	364603X1	9/16	1	Elbow, 90°	Coude à 90°	Codo, 90°
38	6110899M91	Dipper (Yellow) 1050mm	1	Hose Assy	Ensemble de flexible	Flexible, Conj.



880 980
 TX760B TX860B
 TX870B TX970B

831 832 833 841 842 843 845 851 852 853 855 931 932

77007C05.1

6199042M3

1

Jan-06

Digger Controls
Commandes Défonceuse
Mandos de equipo retro

Servo
Servo
Servo

Decals
 Adhésifs
 Adhesivos

C-77007-06.1-A

1	6110875M1	Raise/Lower	1	Decal	Adhésif	Adhesivo
2	6110953M1	Refer to OIB	1	Decal	Adhésif	Adhesivo
3	6110876M1	Pattern	1	Decal	Adhésif	Adhesivo
4	6110954M1	Terex Crown	1	Decal	Adhésif	Adhesivo

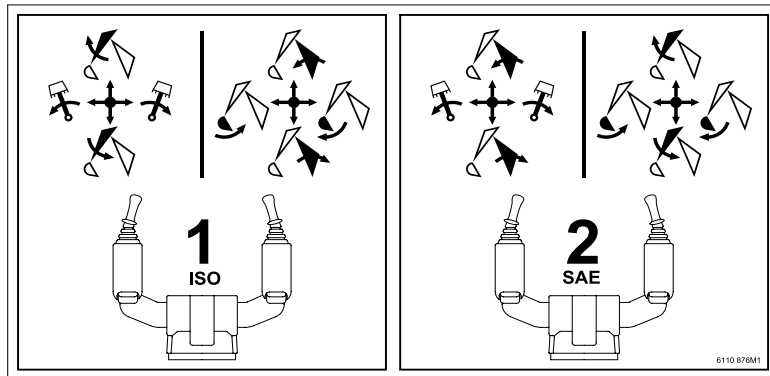
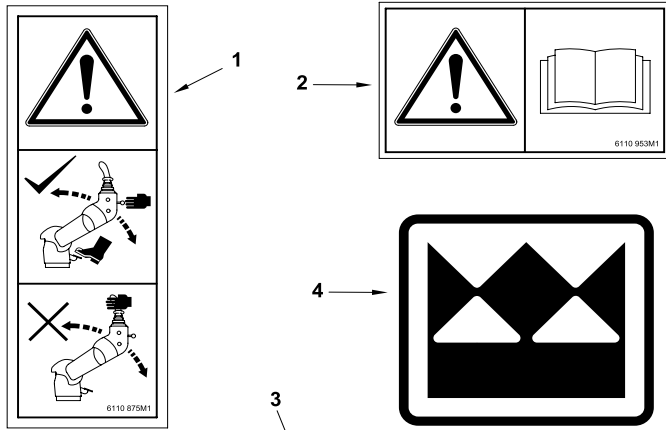

880 980
 TX760B TX860B
 TX870B TX970B

831 832 833 841 842 843 845 851 852 853 855 931 932

Digger Controls
Commandes Défonceuse
Mandos de equipo retro

Servo
Servo
Servo

Pivot
 Pivot
 Pivote

C-77008-01.1-A

1	6110949M91		1	Pivot Assy	Ensemble de pivot	Pivote, Conj.
2	6111250M1		1	Seal	Joint	Junta
3	6111082M91		1	Support Assy	Ensemble de support	Apoyadero, Conj.
4	390972X1	M8	4	Washer	Rondelle	Arandela
5	339287X1	M8 x 35	4	Screw	Vis	Tornillo
6	3009507X1	M12 x 35	1	Bolt	Boulon	Perno
7	390735X1	M12	3	Washer	Rondelle	Arandela
8	1442190X1	M12	1	Nut, Lock	Écrou de blocage	Tuerca de retención
9	6110776M91		1	Pedal Assy	Ensemble de pédale	Pedal, Conj.
10	6110893M1		1	Spring	Ressort	Muelle
11	339337X1	M8 x 30	1	Bolt	Boulon	Perno
12	339169X1	M8	1	Nut	Écrou	Tuerca
13	6110473M1	Mini	1	Relay	Relais	Relé
14	3512552M1	M5 x 12	1	Screw	Vis	Tornillo
15	3512553M1	M5	1	Washer	Rondelle	Arandela

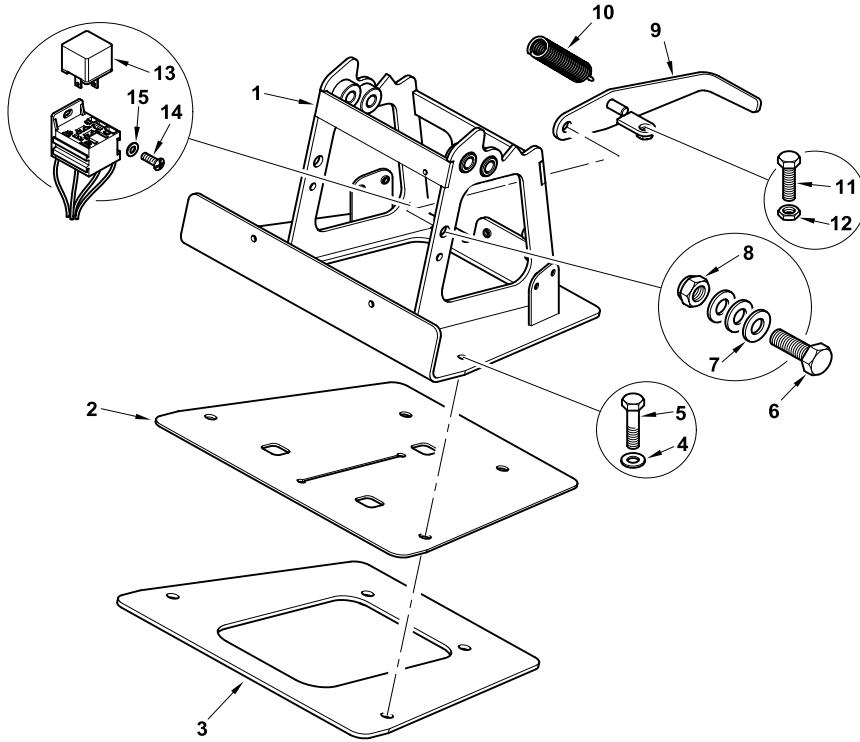

880
 TX760B TX860B
 TX870B

832 834 842 844 852 854

77008C01.1

6199042M3

1

Jan-06

Digger Controls
Commandes Défonceuse
Mandos de equipo retro

Servo
Servo
Servo

Control Bar
Commandez la barre
Control bar

C-77008-02.1-A

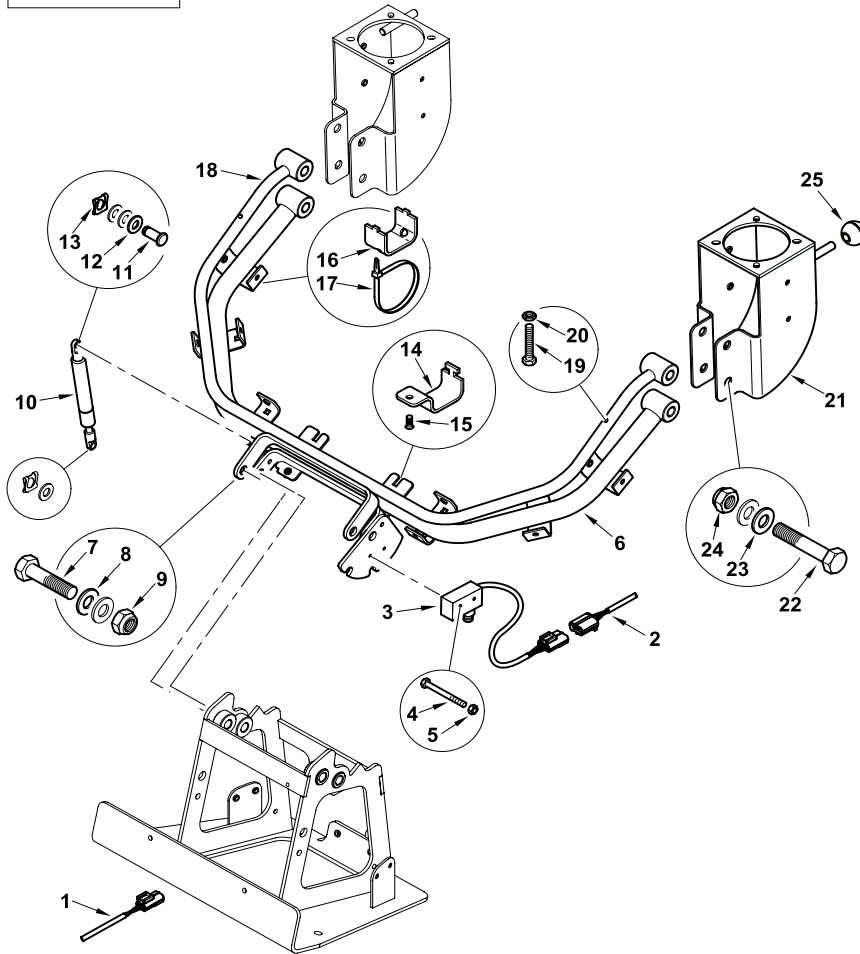

1	6110886M92	Supplementary Chassis	1	Harness Assy	Ensemble de faisceau	Haz, Conj.
2	6110885M92	Yolk	1	Harness Assy	Ensemble de faisceau	Haz, Conj.
3	6110884M91		1	Switch Assy	Ensemble commutat.	Conmutador, Conj.
4	6110887M1	M3 Special	2	Bolt	Boulon	Perno
5	391216X1	M3	2	Nut	Écrou	Tuerca
6	6110765M91		1	Bar	Barre	Barra
7	6110850M1	M12 x 50 Special	4	Bolt	Boulon	Perno
8	390735X1	M12	8	Washer	Rondelle	Arandela
9	1442190X1	M12	4	Nut, Lock	Écrou de blocage	Tuerca de retención
10	6110849M91		1	Gas Strut	Vérin à gaz	Gato de gas
11	6102816M1		1	Pin, Clevis	Axe de chape	Eje de brida
12	390972X1	M8	5	Washer	Rondelle	Arandela
13	3516322M1		2	Clip	Clip	Clip
14	6110890M1		2	Clamp	Collier de serrage	Argolla de cierre
15	3512552M1	M5 x 12	2	Screw	Vis	Tornillo
16	6110785M1		6	Clamp	Collier de serrage	Argolla de cierre
17	1876229M1		6	Tie, Cable	Attache câble	Enlace de Cable
18	6110770M91		1	Bar	Barre	Barra
19	339351X1	M6 x 25	2	Screw	Vis	Tornillo
20	391255X1	M6	2	Nut	Écrou	Tuerca
21	6110873M91	LH Joystick	1	Bracket Assy	Ensemble chaise palier	Cuchara, Conj.
21	6110808M91	RH Joystick	1	Bracket Assy	Ensemble chaise palier	Cuchara, Conj.
22	6110851M1	M12 x 65 Special	4	Bolt	Boulon	Perno
23	390735X1	M12	8	Washer	Rondelle	Arandela
24	1442190X1	M12	4	Nut, Lock	Écrou de blocage	Tuerca de retención
25	3517899M1		2	Knob	Boule	Bola



880
 TX760B TX860B
 TX870B

832 834 842 844 852 854

77008C02.1

6199042M3

1

Jan-06

Digger Controls
Commandes Défonceuse
Mandos de equipo retro

Servo
Servo
Servo

Pilot Control
 Asservissement
 Control pilotaje

C-77008-03.1-A

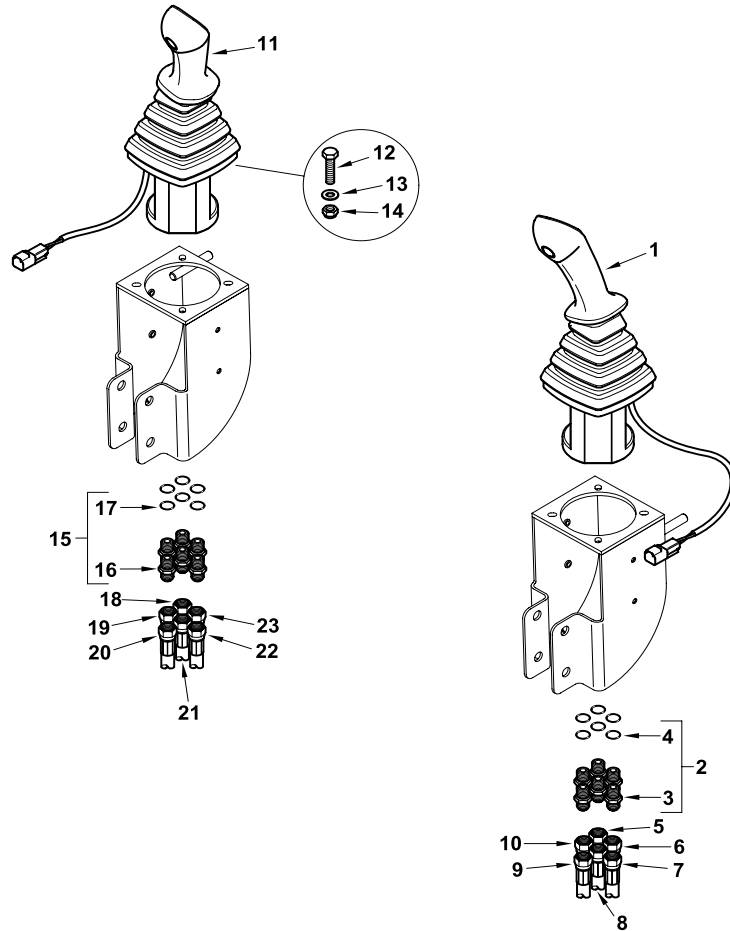

1	6110915M91	LH	1	Joystick	Manche	Palanca de mando
2	835091M91	9/16	6	Union	Union	Unión
3		2 Ref. 2	1	Union	Union	Unión
4	831452M1	2	1	O-Ring	Joint torique	Junta de tipo O
5	6110909M91	Tank 1900mm	1	Hose Assy	Ensemble de flexible	Flexible, Conj.
6	6110901M91	[77007C05.1 20] Boom (Orange) 1100mm	1	Hose Assy	Ensemble de flexible	Flexible, Conj.
7	6110904M91	Slew (Green) 1150mm	1	Hose Assy	Ensemble de flexible	Flexible, Conj.
8	6110907M91	Pressure (Grey) 2050mm	1	Hose Assy	Ensemble de flexible	Flexible, Conj.
9	6110896M91	[77007C05.1 33] Boom (Blue) 1000mm	1	Hose Assy	Ensemble de flexible	Flexible, Conj.
10	6110906M91	Slew (Purple) 1250mm	1	Hose Assy	Ensemble de flexible	Flexible, Conj.
11	6110916M91	RH	1	Joystick	Manche	Palanca de mando
12	339351X1	M6 x 25	8	Screw	Vis	Tornillo
13	390971X1	M6	16	Washer	Rondelle	Arandela
14	1441500X1	M6	8	Nut, Lock	Écrou de blocage	Tuerca de retención
15	835091M91	9/16	6	Union	Union	Unión
16		15 Ref. 15	1	Union	Union	Unión
17	831452M1	15	1	O-Ring	Joint torique	Junta de tipo O
18	6110910M91	Tank 2000mm	1	Hose Assy	Ensemble de flexible	Flexible, Conj.
19	6110903M91	Bucket (Brown) 1150mm	1	Hose Assy	Ensemble de flexible	Flexible, Conj.
20	6110898M91	[77007C05 24] Dipper (Red) 950mm	1	Hose Assy	Ensemble de flexible	Flexible, Conj.
21	6110908M91	Pressure (Grey) 1700mm	1	Hose Assy	Ensemble de flexible	Flexible, Conj.
22	6110905M91	Bucket (White) 1250mm	1	Hose Assy	Ensemble de flexible	Flexible, Conj.
22	6110899M91	[77007C05.1 38] Dipper (Yellow) 1050mm	1	Hose Assy	Ensemble de flexible	Flexible, Conj.



880
 TX760B TX860B
 TX870B

832 834 842 844 852 854

77008C03.1

6199042M3

1

Jan-06

Digger Controls
Commandes Défonceuse
Mandos de equipo retro

Servo
Servo
Servo

Trim
 Finition
 Ajuste

C-77008-04.1-A

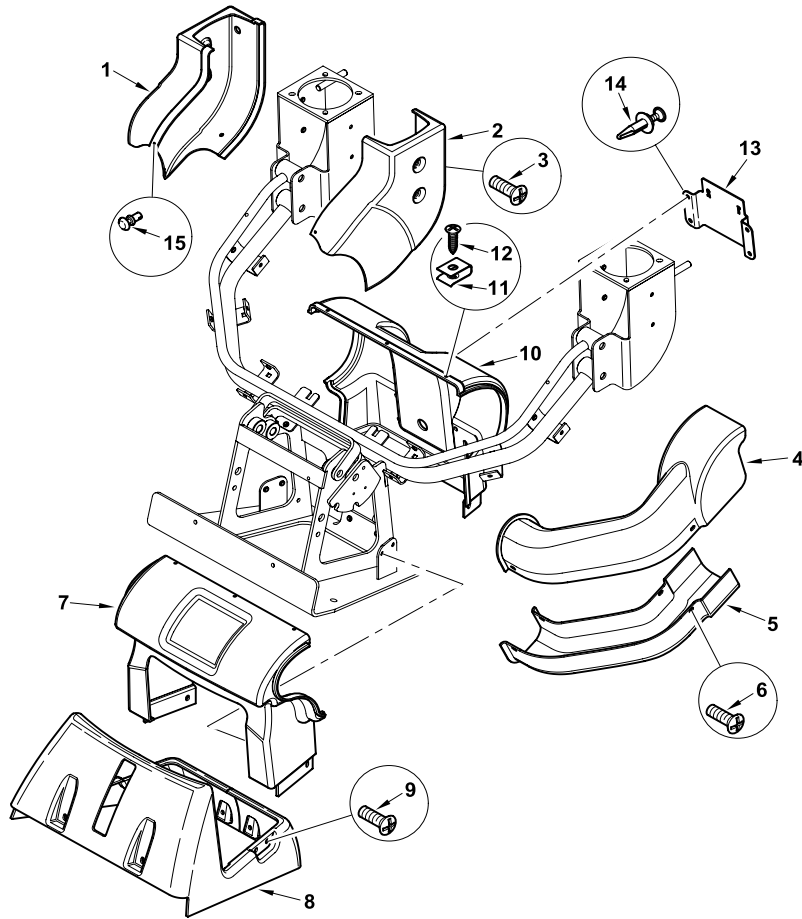

1	6110871M1	LH	1	Cover	Cache	Tapa
1	6110800M1	RH	1	Cover	Cache	Tapa
2	6110872M1	LH	1	Cover	Cache	Tapa
2	6110801M1	RH	1	Cover	Cache	Tapa
3	3512552M1	M5 x 12	12	Screw	Vis	Tornillo
4	6110804M1	LH	1	Cover	Cache	Tapa
4	6110805M1	RH	1	Cover	Cache	Tapa
5	6110802M1	LH	1	Cover	Cache	Tapa
5	6110803M1	RH	1	Cover	Cache	Tapa
6	3512552M1	M5 x 12	8	Screw	Vis	Tornillo
7	6110807M1	Rear	1	Cover	Cache	Tapa
8	6111080M1		1	Lower Skirt Moulding	Moulage Tablier inférieur	Moldura falda inferior
9	3512552M1	M5 x 12	4	Screw	Vis	Tornillo
10	6110806M1	Front	1	Cover	Cache	Tapa
11	6110888M1		3	Nut, U	Écrou en U	Tuerca en U
12	6110889M1		3	Screw	Vis	Tornillo
13	6110952M1		1	Plate, Cover	Plaque de fermeture	Placa de cierre
14	6101591M1	Plastic	4	Rivet	Rivet	Remache
15	6111193M1	Plastic	2	Rivet	Rivet	Remache



880
 TX760B TX860B
 TX870B

832 834 842 844 852 854

77008C04.1

6199042M3

1

Jan-06

Digger Controls
Commandes Défonceuse
Mandos de equipo retro

Servo
Servo
Servo

Change over valve
 Valve de changement
 Válvula de cambio

C-77008-05.1-A

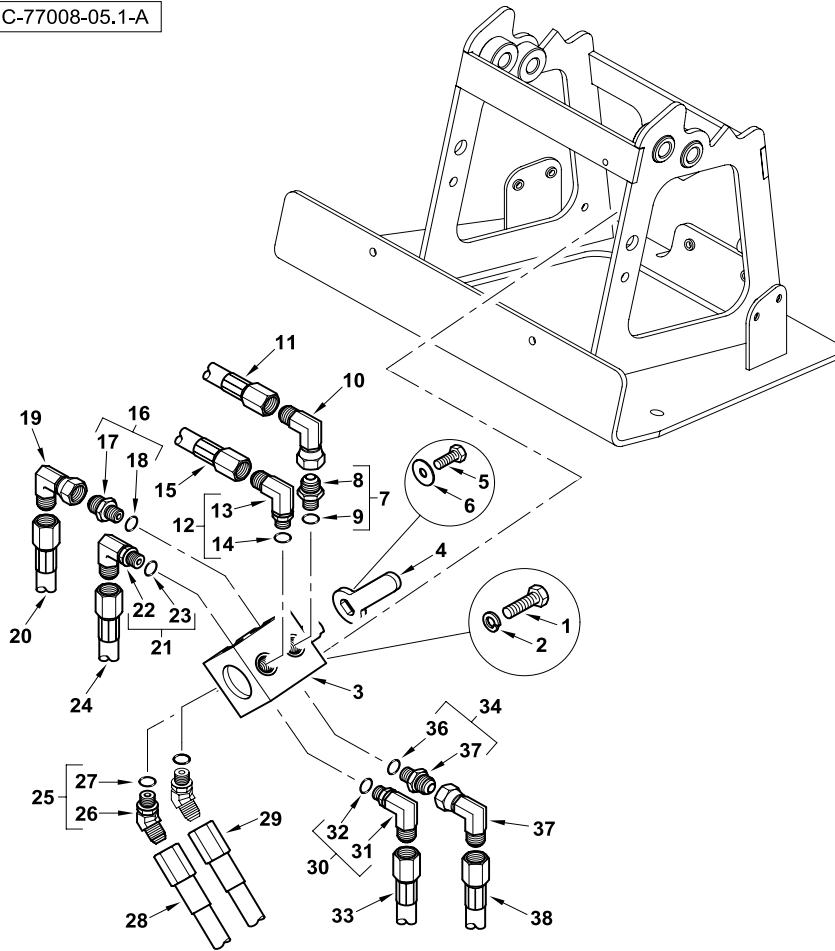

1	339666X1	M6 x 20	2	Screw	Vis	Tornillo
2	339375X1	M6	2	Washer, Lock	Rondelle de blocage	Arandela de freno
3	6110813M1		1	Valve, Control	Distributeur	Distribuidor
4	6110853M1		1	Lever	Levier	Palanca
5	339560X1	M6 x 16	1	Screw	Vis	Tornillo
6	391038X1	M6	1	Washer	Rondelle	Arandela
7	367407X91		1	Connector Assy	Ensemble connexion	Conexión, Conj.
8		7	1	Connector	Connecteur	Conector
9	831452M1	7	1	O-Ring	Joint torique	Junta de tipo O
10	364603X1	9/16	1	Elbow, 90°	Coude à 90°	Codo, 90°
11	6110902M91	Boom (Orange) 640mm	1	Hose Assy	Ensemble de flexible	Flexible, Conj.
12	373739X91		1	Elbow, 90°	Coude à 90°	Codo, 90°
13		12	1	Elbow	Coude	Codo
14	831452M1	12	1	O-Ring	Joint torique	Junta de tipo O
15	6110897M91	Dipper (Red) 470mm	1	Hose Assy	Ensemble de flexible	Flexible, Conj.
16	367407X91		1	Connector Assy	Ensemble connexion	Conexión, Conj.
17		16	1	Connector	Connecteur	Conector
18	831452M1	16	1	O-Ring	Joint torique	Junta de tipo O
19	364603X1	9/16	1	Elbow, 90°	Coude à 90°	Codo, 90°
20		Boom [77007C03.1 6]	1	Hose Assy	Ensemble de flexible	Flexible, Conj.
21	373739X91		1	Elbow, 90°	Coude à 90°	Codo, 90°
22		21	1	Elbow	Coude	Codo
23	831452M1	21	1	O-Ring	Joint torique	Junta de tipo O
24		Dipper [77007C03.1 19]	1	Hose Assy	Ensemble de flexible	Flexible, Conj.
25	6110919M91		2	Elbow, 45°	Coude à 45°	Codo, 45°
26		25	1	Elbow	Coude	Codo
27	831495M1	25	1	O-Ring	Joint torique	Junta de tipo O
28	6110895M91	Boom (Blue) 350mm	1	Hose Assy	Ensemble de flexible	Flexible, Conj.
29	6110900M91	Dipper (Yellow) 400mm	1	Hose Assy	Ensemble de flexible	Flexible, Conj.
30	373739X91		1	Elbow, 90°	Coude à 90°	Codo, 90°
31		30	1	Elbow	Coude	Codo
32	831452M1	30	1	O-Ring	Joint torique	Junta de tipo O
33		Boom [77007C03.1 9]	1	Hose Assy	Ensemble de flexible	Flexible, Conj.
34	367407X91		1	Connector Assy	Ensemble connexion	Conexión, Conj.
35		34	1	Connector	Connecteur	Conector
36	831452M1	34	1	O-Ring	Joint torique	Junta de tipo O
37	364603X1	9/16	1	Elbow, 90°	Coude à 90°	Codo, 90°
38	6110899M91	Dipper (Yellow) 1050mm	1	Hose Assy	Ensemble de flexible	Flexible, Conj.



880
 TX760B TX860B
 TX870B

832 834 842 844 852 854

Digger Controls
Commandes Défonceuse
Mandos de equipo retro

Servo
Servo
Servo

Decals
 Adhésifs
 Adhesivos

C-77008-06.1-A

1	6110875M1	Raise/Lower	1	Decal	Adhésif	Adhesivo
2	6111155M1	Pattern	1	Decal	Adhésif	Adhesivo
3	6110954M1	Terex Crown	1	Decal	Adhésif	Adhesivo
4	6110953M1	Refer to OIB	1	Decal	Adhésif	Adhesivo

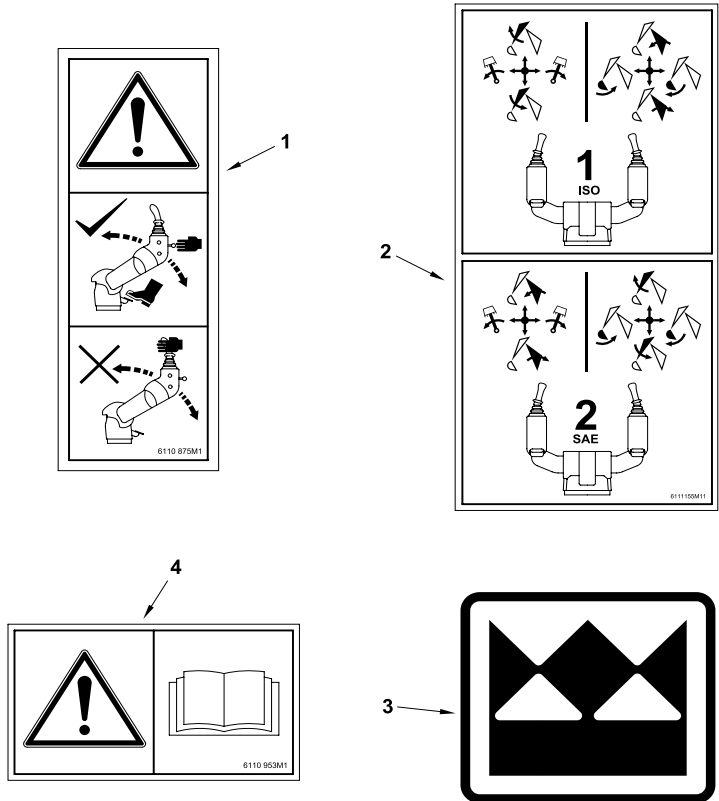

880
 TX760B TX860B
 TX870B

832 834 842 844 852 854

Dipper
Balancier
Balancín

Extendahoe
Extendahoe
Extendahoe

C-73002-01.1-A

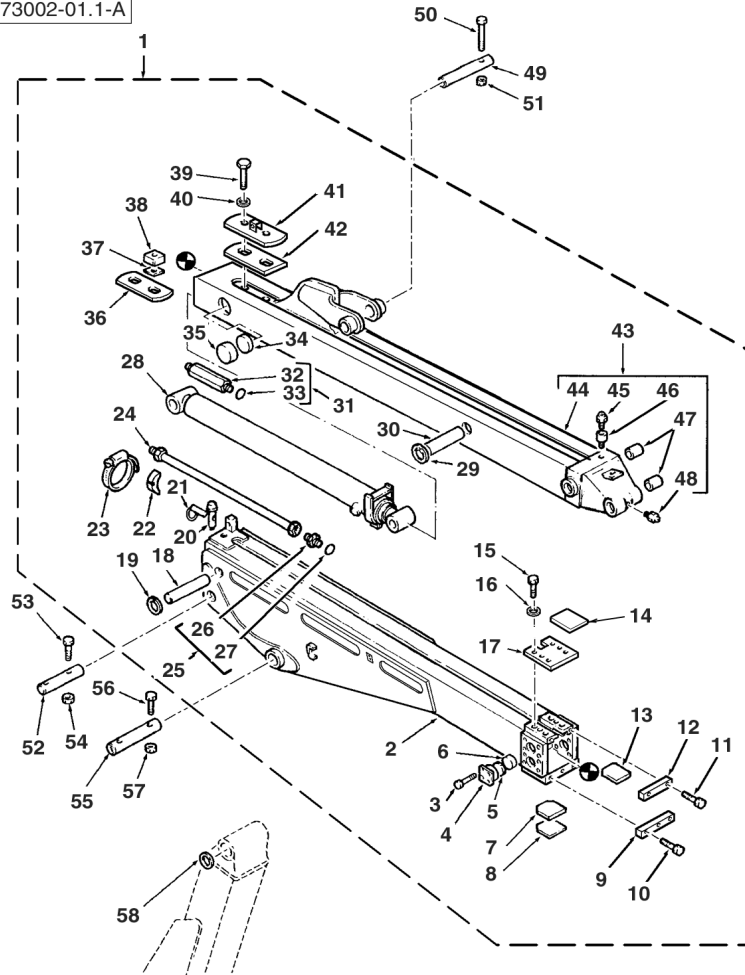

1	6109586M91			1	Dipperstick Assy	Ensemble de balancier	Balancín, Conj.
2	6100743M96	1		1	Housing Assy	Ensemble de carter	Cárter, Conj.
3	3009492X1	1	M10 x 25	16	Screw	Vis	Tornillo
4	6106121M1	1		4	Housing	Carter	Cárter
5	3510645M1	1	(E) 1,0 mm	X	Shim	Cale	Calce
5	3502476M1	1	(E) 2,0 mm	X	Shim	Cale	Calce
6	3502475M2	1	(A,C)	4	Pad, Wear	Patin d'usure	Patin de desgaste
7	3501658M2	1		1	Pad, Wear	Patin d'usure	Patin de desgaste
8	3510862M1	1	(E) 0,5 mm	X	Shim	Cale	Calce
8	3502940M1	1	(E) 1,0 mm	X	Shim	Cale	Calce
8	3502939M1	1	(E) 2,0 mm	X	Shim	Cale	Calce
8	3502938M1	1	(E) 4,0 mm	X	Shim	Cale	Calce
9	6106164M1	1		1	Plate	Plaque	Placa
10	6007797M1	1	M12 x 30	3	Screw	Vis	Tornillo
11	6007797M1	1	M12 x 30	2	Screw	Vis	Tornillo
12	6102971M1	1		1	Retainer	Dispositif de retenue	Fijación
13	3501658M2	1	(A,C)	1	Pad, Wear	Patin d'usure	Patin de desgaste
14	6108692M1	1	Read O.I.B.	4	Decal	Adhésif	Adhesivo
15	514-819	1	M12 x 35	6	Screw	Vis	Tornillo
16	385363X1	1	M12	6	Washer	Rondelle	Arandela
17	6102970M1	1		1	Plate	Plaque	Placa
18	3501624M1	1	31.7 x 195 mm	1	Pin	Axe	Pasador
19	355973X1	1		2	Ring, Snap	Anneau d'arrêt	Anillo de resorte
20	6108900M1	1		1	Pin	Axe	Pasador
21	810285M92	1		1	Pin, Linch	Goupille d'arrêt	Pasador de parada
22	D142787	1		2	Mount, Rubber	Support caoutchouc	Bloque de caucho
23	3517728M1	1		2	Clip	Clip	Clip
24	6100599M91	1		1	Tube Assy	Tuyauterie	Conjunto de tubería
25	835013M91	1		1	Connector Assy	Ensemble connexion	Conexión, Conj.
26		25	➡ Ref. 25	1	Union	Union	Unión
27	835024M1	25		1	O-Ring	Joint torique	Junta de tipo O
28	5000127M91	1	👁 73002C02.1 1	1	Cylinder Assy	Ensemble de vérin	Gato, Conj.
29	355973X1	1		2	Ring, Snap	Anneau d'arrêt	Anillo de resorte
30	3501625M1	1	31.7 x 133 mm	1	Pin	Axe	Pasador
31	6100603M91	1		1	Union	Union	Unión
32		31	➡ Ref. 31	1	Union	Union	Unión
33	835024M1	31		1	O-Ring	Joint torique	Junta de tipo O
34	3510644M1	1	(E) 1,0 mm	X	Shim	Cale	Calce



820 860 880 970 980
TX760B TX860B
TX870B TX970B

801 802 803 804 805 806 807 808 809 810 811 812 813 814 815 816 817 821 822
823 824 825 831 832 833 834 841 842 843 844 845 851 852 853 854 855 921 922
923 931 932

73002C01.1

6199042M3

1

Jan-06

Dipper
Balancier
Balancín

Extendahoe
Extendahoe
Extendahoe

C-73002-01.1-A

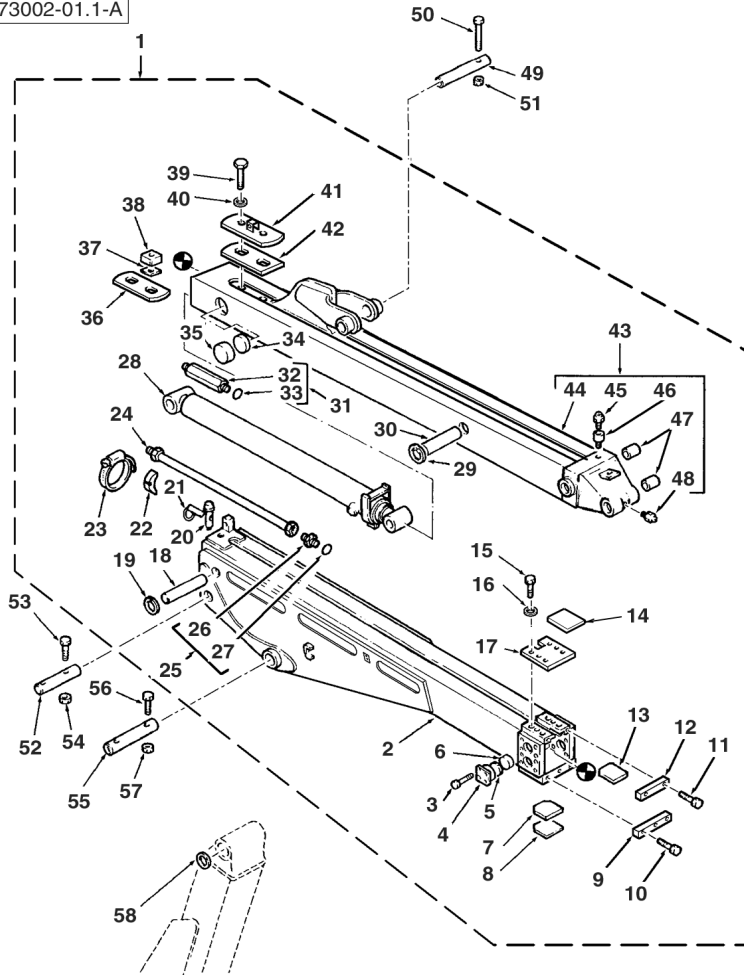

34	3502477M1	1	(E) 2,0 mm	X	Shim	Cale	Calce
35	3502473M2	1	(A) Torque Figures Inner	2	Pad, Wear	Patin d'usure	Patín de desgaste
36	6102559M1	1	(A) Lower	1	Pad, Wear	Patin d'usure	Patín de desgaste
37	3501975M2	1	Top 1,0 mm	2	Shim	Cale	Calce
37	3502975M2	1	Bottom 2,0 mm	2	Shim	Cale	Calce
37	3502976M2	1	3,0 mm	2	Shim	Cale	Calce
38	3501655M2	1		2	Spacer	Entretoise	Traviesa
39	3517491M1	1	(A) M24 x 90	2	Screw	Vis	Tornillo
40	896-11024	1	26 x 44 x 5 mm	2	Washer	Rondelle	Arandela
41	6102519M91	1		1	Plate	Plaque	Placa
42	6102518M1	1	(A) Upper	1	Pad, Wear	Patin d'usure	Patín de desgaste
43	3504158M98	1		1	Extension Assy	Ensemble de rallonge	Extensión, Conj.
44		43	Ref. 43	1	Body	Corps	Cuerpo
45	339608X1	43		1	Fitting, Grease	Graisneur	Engrasador
46	3504012M1	1		1	Adaptor	Adaptateur	Adaptador
47	3500009M3	1		4	Bushing	Bague	Anillo
48	339608X1	1		1	Fitting, Grease	Graisneur	Engrasador
49	3522720M2		45 x 250 mm	1	Pin	Axe	Pasador
50	3501289M1		M10 x 110	1	Screw	Vis	Tornillo
51	1440329X1		M10	1	Nut, Lock	Écrou de blocage	Tuerca de retención
52	3522693M2		45 x 310 mm	1	Pin	Axe	Pasador
53	3501289M1		M10 x 110	2	Screw	Vis	Tornillo
54	1440329X1		M10	2	Nut, Lock	Écrou de blocage	Tuerca de retención
55	3522693M2		45 x 310 mm	1	Pin	Axe	Pasador
56	3501289M1		M10 x 110	2	Screw	Vis	Tornillo
57	1440329X1		M10	2	Nut, Lock	Écrou de blocage	Tuerca de retención
58	3501027M1			2	Washer	Rondelle	Arandela
NI	6193766M91		(B)	1	Kit, Parts	Lot de pièces	Juego de piezas
NI	6193768M91		(D)	1	Kit, Parts	Lot de pièces	Juego de piezas
NI	3510860M91		(F)	1	Kit, Shim	Jeu de cales	Juego de calces

- A Included in kit marked (B)
Inclus dans jeu marqué (B)
Incluido en juego marcado (B)
- C Included in kit marked (D)
Inclus dans jeu marqué (D)
Incluido en juego marcado (D)
- E Included in kit marked (F)
Inclus dans jeu marqué (F)
Incluido en juego marcado (F)

- B Contains items marked (A)
Comprend les pièces marquées (A)
Incluye las piezas marcadas (A)
- D Contains items marked (C)
Comprend les pièces marquées (C)
Incluye las piezas marcadas (C)
- F Contains items marked (E)
Comprend les pièces marquées (E)
Incluye las piezas marcadas (E)



820 860 880 970 980
TX760B TX860B
TX870B TX970B

801 802 803 804 805 806 807 808 809 810 811 812 813 814 815 816 817 821 822
823 824 825 831 832 833 834 841 842 843 844 845 851 852 853 854 855 921 922
923 931 932

73002C01.1

6199042M3

1

Jan-06

Dipper
Balancier
Balancín

Extendahoe
Extendahoe
Extendahoe

Cylinder
Cylindre
Cilindro

C-73002-02.1-A

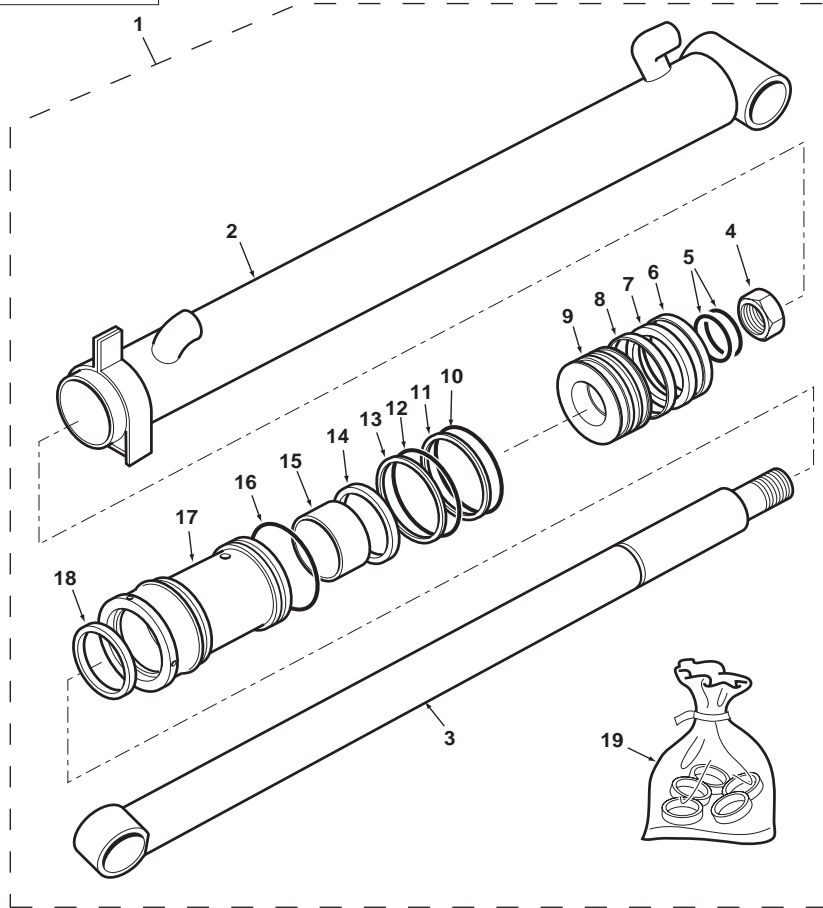

1	5000127M91		73002C01.1 28	1	Cylinder Assy	Ensemble de vérin	Gato, Conj.
2	5003920M91	1		1	Cylinder	Cylindre	Cilindro
3	5005266M91	1		1	Piston, Cylinder	Piston de vérin	Pistón de gato
4	1607689M1	1		1	Nut, Lock	Écrou de blocage	Tuerca de retención
5	1748324M1	1 (A)		2	O-Ring	Joint torique	Junta de tipo O
6	3487078M1	1		1	Ring	Anneau	Aro
7	3443573M2	1 (A)		1	Seal	Joint	Junta
8	3487078M1	1 (A)		1	Ring	Anneau	Aro
9	5003929M1	1		1	Piston	Piston	Pistón
10	1442891X1	1 (A)		1	O-Ring	Joint torique	Junta de tipo O
11	5001306M1	1 (A)		1	Ring, Backup	Contre-joint	ContraJunta
12	1441120X1	1 (A)		1	O-Ring	Joint torique	Junta de tipo O
13	1881527M1	1 (A)		1	Ring	Anneau	Aro
14	3485976M1	1 (A)		1	Seal	Joint	Junta
15	5001605M1	1		1	Bearing	Coussinet	Cojinete
16	3487585M1	1 (A)		1	O-Ring	Joint torique	Junta de tipo O
17	5004084M91	1		1	Bearing	Coussinet	Cojinete
18	1605446M1	1 (A)		1	Wiper	Racleur	Raspador, Escobilla
19	5005362M91	(B)		X	Kit, Seal	Pochette de joints	Juego de juntas

A Included in kit marked (B)
Inclus dans jeu marqué (B)
Incluido en juego marcado (B)

B Contains items marked (A)
Comprend les pièces marquées (A)
Incluye las piezas marcadas (A)



820 860 880 970 980
TX760B TX860B
TX870B TX970B

801 802 803 804 805 806 807 808 809 810 811 812 813 814 815 816 817 821 822
823 824 825 831 832 833 834 841 842 843 844 845 851 852 853 854 855 921 922
923 931 932

73002C02.1

6199042M3

1

Jan-06

Dipper
Balancier
Balancín

Extendahoe
Extendahoe
Extendahoe

Case Bucket
Godet Case
Cuchara de superficie

C-73004-01.1-A

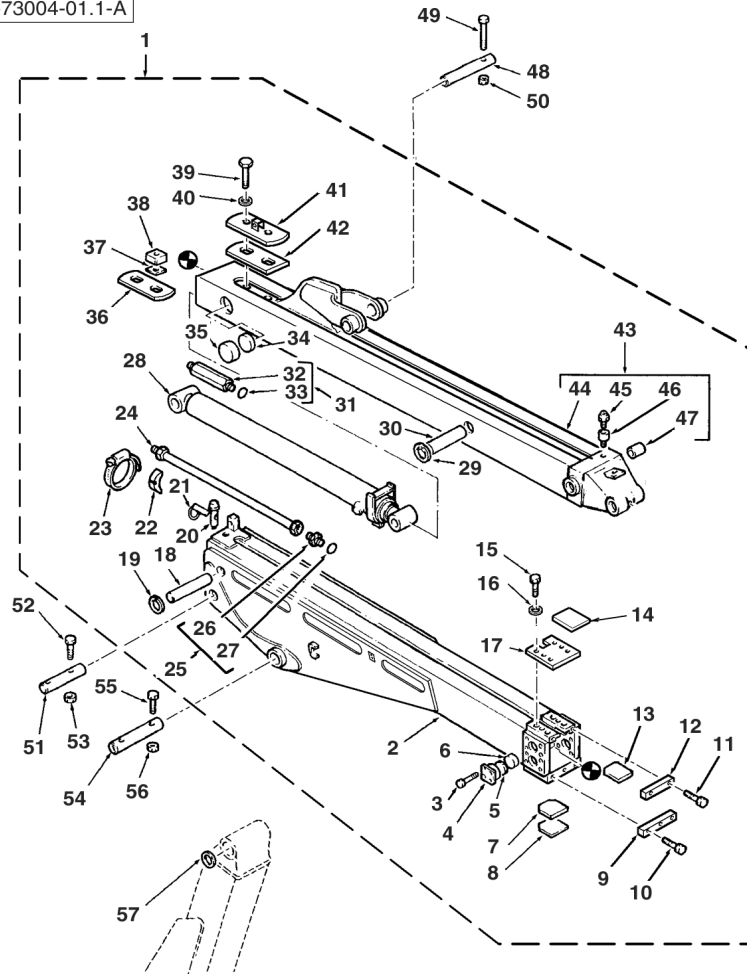

1	6109587M91			1	Dipperstick Assy	Ensemble de balancier	Balancín, Conj.
2	6100743M96	1		1	Housing Assy	Ensemble de carter	Cárter, Conj.
3	3009492X1	1	M10 x 25	16	Screw	Vis	Tornillo
4	6106121M1	1		4	Housing	Carter	Cárter
5	3510645M1	1	(E) 1,0 mm	X	Shim	Cale	Calce
5	3502476M1	1	(E) 2,0 mm	X	Shim	Cale	Calce
6	3502475M2	1	(A,C)	4	Pad, Wear	Patin d'usure	Patín de desgaste
7	3501658M2	1		1	Pad, Wear	Patin d'usure	Patín de desgaste
8	3510862M1	1	(E) 0,5 mm	X	Shim	Cale	Calce
8	3502940M1	1	(E) 1,0 mm	X	Shim	Cale	Calce
8	3502939M1	1	(E) 2,0 mm	X	Shim	Cale	Calce
8	3502938M1	1	(E) 4,0 mm	X	Shim	Cale	Calce
9	6106164M1	1		1	Plate	Plaque	Placa
10	6007797M1	1	M12 x 30	5	Screw	Vis	Tornillo
12	6102971M1	1		1	Retainer	Dispositif de retenue	Fijación
13	3501658M2	1	(A,C)	1	Pad, Wear	Patin d'usure	Patín de desgaste
14	6108692M1	1	Read O.I.B.	4	Decal	Adhésif	Adhesivo
15	514-819	1	M12 x 35	6	Screw	Vis	Tornillo
16	385363X1	1	M12	6	Washer	Rondelle	Arandela
17	6102970M1	1		1	Plate	Plaque	Placa
18	3501624M1	1	31.7 x 195 mm	1	Pin	Axe	Pasador
19	355973X1	1		2	Ring, Snap	Anneau d'arrêt	Anillo de resorte
20	6108900M1	1		1	Pin	Axe	Pasador
21	810285M92	1		1	Pin, Linch	Goupille d'arrêt	Pasador de parada
22	D142787	1		2	Mount, Rubber	Support caoutchouc	Bloque de caucho
23	3517728M1	1		2	Clip	Clip	Clip
24	6100599M91	1		1	Tube Assy	Tuyauterie	Conjunto de tubería
25	835013M91	1		1	Connector Assy	Ensemble connexion	Conexión, Conj.
26		25	➡ Ref. 25	1	Union	Union	Unión
27	835024M1	25		1	O-Ring	Joint torique	Junta de tipo O
28	5000127M91	1	👁 73004C02.1 1	1	Cylinder Assy	Ensemble de vérin	Gato, Conj.
29	355973X1	1		2	Ring, Snap	Anneau d'arrêt	Anillo de resorte
30	3501625M1	1	31.7 x 133 mm	1	Pin	Axe	Pasador
31	6100603M91	1		1	Union	Union	Unión
32		31	➡ Ref. 31	1	Union	Union	Unión
33	835024M1	31		1	O-Ring	Joint torique	Junta de tipo O
34	3510644M1	1	(E) 1,0 mm	X	Shim	Cale	Calce



820 860 880 970 980
TX760B TX860B
TX870B TX970B

801 802 803 804 805 806 807 808 813 814 815 816 817 821 822 823 824 825 831
832 833 834 841 842 843 844 845 851 852 853 854 855 921 922 923 931 932

73004C01.1

6199042M3

1

Jan-06

Dipper
Balancier
Balancín

Extendahoe
Extendahoe
Extendahoe

Case Bucket
Godet Case
Cuchara de superficie

C-73004-01.1-A

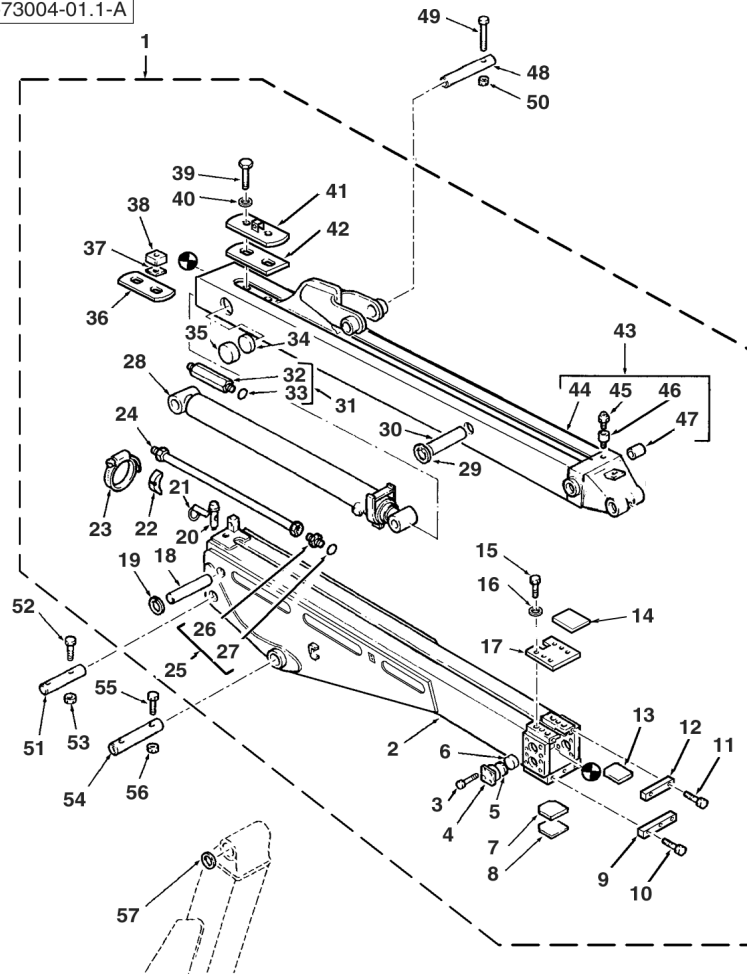

34	3502477M1	1	(E) 2,0 mm	X	Shim	Cale	Calce
35	3502473M2	1	(A) Inner	2	Pad, Wear	Patin d'usure	Patín de desgaste
36	6102559M1	1	(A) Torque Figures Lower	1	Pad, Wear	Patin d'usure	Patín de desgaste
37	3501975M2	1	1,0 mm	2	Shim	Cale	Calce
37	3502975M2	1	Top 2,0 mm	2	Shim	Cale	Calce
37	3502976M2	1	Bottom 3,0 mm	2	Shim	Cale	Calce
38	3501655M2	1		2	Spacer	Entretoise	Traviesa
39	3517491M1	1	(A) M24 x 90	2	Screw	Vis	Tornillo
40	896-11024	1	26 x 44 x 5 mm	2	Washer	Rondelle	Arandela
41	6102519M91	1		1	Plate	Plaque	Placa
42	6102518M1	1	(A) Upper	1	Pad, Wear	Patin d'usure	Patín de desgaste
43	6100303M93	1		1	Extension Assy	Ensemble de rallonge	Extensión, Conj.
44		43	Ref. 43	1	Body	Corps	Cuerpo
45	339608X1	43		1	Fitting, Grease	Graisneur	Engrasador
46	3504012M1	43		1	Adaptor	Adaptateur	Adaptador
47	3500009M3	43		2	Bushing	Bague	Anillo
48	3522720M2		45 x 250 mm	1	Pin	Axe	Pasador
49	3501289M1		M10 x 110	1	Screw	Vis	Tornillo
50	1440329X1		M10	1	Nut, Lock	Écrou de blocage	Tuerca de retención
51	3522693M2		45 x 310 mm	1	Pin	Axe	Pasador
52	3501289M1		M10 x 110	2	Screw	Vis	Tornillo
53	1440329X1		M10	2	Nut, Lock	Écrou de blocage	Tuerca de retención
54	3522693M2		45 x 310 mm	1	Pin	Axe	Pasador
55	3501289M1		M10 x 110	2	Screw	Vis	Tornillo
56	1440329X1		M10	2	Nut, Lock	Écrou de blocage	Tuerca de retención
57	3501027M1			2	Washer	Rondelle	Arandela
NI	6193766M91		(B)	1	Kit, Parts	Lot de pièces	Juego de piezas
NI	6193768M91		(D)	1	Kit, Parts	Lot de pièces	Juego de piezas
NI	3510860M91		(F)	1	Kit, Shim	Jeu de cales	Juego de calces

A Included in kit marked (B)
Inclus dans jeu marqué (B)
Incluido en juego marcado (B)

C Included in kit marked (D)
Inclus dans jeu marqué (D)
Incluido en juego marcado (D)

E Included in kit marked (F)
Inclus dans jeu marqué (F)
Incluido en juego marcado (F)

B Contains items marked (A)
Comprend les pièces marquées (A)
Incluye las piezas marcadas (A)

D Contains items marked (C)
Comprend les pièces marquées (C)
Incluye las piezas marcadas (C)

F Contains items marked (E)
Comprend les pièces marquées (E)
Incluye las piezas marcadas (E)



820 860 880 970 980
TX760B TX860B
TX870B TX970B

801 802 803 804 805 806 807 808 813 814 815 816 817 821 822 823 824 825 831
832 833 834 841 842 843 844 845 851 852 853 854 855 921 922 923 931 932

73004C01.1

6199042M3

1

Jan-06

Dipper
Balancier
Balancín

Extendahoe
Extendahoe
Extendahoe

Cylinder
Cylindre
Cilindro

C-73004-02.1-A

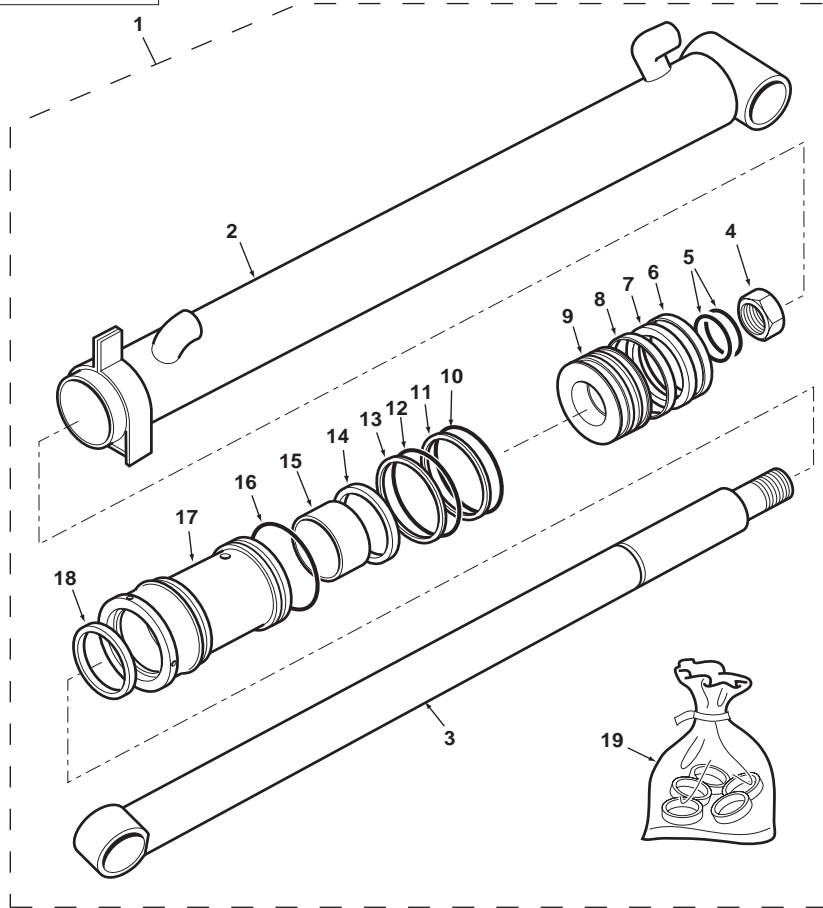

1	5000127M91		73004C01.1 28	1	Cylinder Assy	Ensemble de vérin	Gato, Conj.
2	5003920M91	1		1	Cylinder	Cylindre	Cilindro
3	5005266M91	1		1	Piston, Cylinder	Piston de vérin	Pistón de gato
4	1607689M1	1		1	Nut, Lock	Écrou de blocage	Tuerca de retención
5	1748324M1	1	(A)	2	O-Ring	Joint torique	Junta de tipo O
6	3487078M1	1		1	Ring	Anneau	Aro
7	3443573M2	1	(A)	1	Seal	Joint	Junta
8	3487078M1	1	(A)	1	Ring	Anneau	Aro
9	5003929M1	1		1	Piston	Piston	Pistón
10	1442891X1	1	(A)	1	O-Ring	Joint torique	Junta de tipo O
11	5001306M1	1	(A)	1	Ring, Backup	Contre-joint	ContraJunta
12	1441120X1	1	(A)	1	O-Ring	Joint torique	Junta de tipo O
13	1881527M1	1	(A)	1	Ring	Anneau	Aro
14	3485976M1	1	(A)	1	Seal	Joint	Junta
15	5001605M1	1		1	Bearing	Coussinet	Cojinete
16	3487585M1	1	(A)	1	O-Ring	Joint torique	Junta de tipo O
17	5004084M91	1		1	Bearing	Coussinet	Cojinete
18	1605446M1	1	(A)	1	Wiper	Racleur	Raspador, Escobilla
19	5005362M91		(B)	X	Kit, Seal	Pochette de joints	Juego de juntas

A Included in kit marked (B)
Inclus dans jeu marqué (B)
Incluido en juego marcado (B)

B Contains items marked (A)
Comprend les pièces marquées (A)
Incluye las piezas marcadas (A)



820 860 880 970 980
TX760B TX860B
TX870B TX970B

801 802 803 804 805 806 807 808 813 814 815 816 817 821 822 823 824 825 831
832 833 834 841 842 843 844 845 851 852 853 854 855 921 922 923 931 932

73004C02.1

6199042M3

1

Jan-06

Dipper
Balancier
Balancín

Extendahoe
Extendahoe
Extendahoe

JCB Bucket
Godet JCB
Cuchara JCB

C-73006-01.1-A

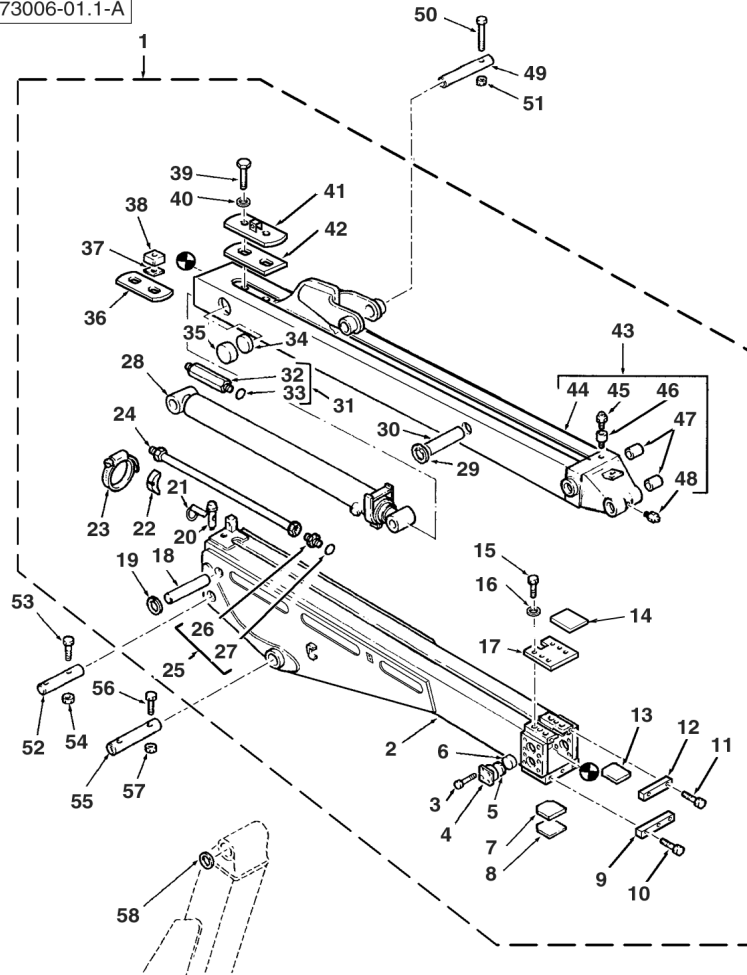

1	6108790M92			1	Dipperstick Assy	Ensemble de balancier	Balancín, Conj.
2	6100743M96	1		1	Housing Assy	Ensemble de carter	Cárter, Conj.
3	3009492X1	1	M10 x 25	16	Screw	Vis	Tornillo
4	6106121M1	1		4	Housing	Carter	Cárter
5	3510645M1	1	(E) 1,0 mm	X	Shim	Cale	Calce
5	3502476M1	1	(E) 2,0 mm	X	Shim	Cale	Calce
6	3502475M2	1	(A,C)	4	Pad, Wear	Patin d'usure	Patin de desgaste
7	3501658M2	1		1	Pad, Wear	Patin d'usure	Patin de desgaste
8	3510862M1	1	(E) 0,5 mm	X	Shim	Cale	Calce
8	3502940M1	1	(E) 1,0 mm	X	Shim	Cale	Calce
8	3502939M1	1	(E) 2,0 mm	X	Shim	Cale	Calce
8	3502938M1	1	(E) 4,0 mm	X	Shim	Cale	Calce
9	6106164M1	1		1	Plate	Plaque	Placa
10	6007797M1	1	M12 x 30	5	Screw	Vis	Tornillo
12	6102971M1	1		1	Retainer	Dispositif de retenue	Fijación
13	3501658M2	1	(A,C)	1	Pad, Wear	Patin d'usure	Patin de desgaste
14	6108692M1	1	Read O.I.B.	4	Decal	Adhésif	Adhesivo
15	514-819	1	M12 x 35	6	Screw	Vis	Tornillo
16	385363X1	1	M12	6	Washer	Rondelle	Arandela
17	6102970M1	1		1	Plate	Plaque	Placa
18	3501624M1	1	31.7 x 195 mm	1	Pin	Axe	Pasador
19	355973X1	1		2	Ring, Snap	Anneau d'arrêt	Anillo de resorte
20	6108900M1	1		1	Pin	Axe	Pasador
21	810285M92	1		1	Pin, Linch	Goupille d'arrêt	Pasador de parada
22	D142787	1		2	Mount, Rubber	Support caoutchouc	Bloque de caucho
23	3517728M1	1		2	Clip	Clip	Clip
24	6100599M91	1		1	Tube Assy	Tuyauterie	Conjunto de tubería
25	835013M91	1		1	Connector Assy	Ensemble connexion	Conexión, Conj.
26		25	➡ Ref. 25	1	Union	Union	Unión
27	835024M1	25		1	O-Ring	Joint torique	Junta de tipo O
28	5000127M91	1	👁 73006C02.1 1	1	Cylinder Assy	Ensemble de vérin	Gato, Conj.
29	355973X1	1		2	Ring, Snap	Anneau d'arrêt	Anillo de resorte
30	3501625M1	1	31.7 x 133 mm	1	Pin	Axe	Pasador
31	6100603M91	1		1	Union	Union	Unión
32		31	➡ Ref. 31	1	Union	Union	Unión
33	835024M1	31		1	O-Ring	Joint torique	Junta de tipo O
34	3510644M1	1	(E) 1,0 mm	X	Shim	Cale	Calce



820 860 880 970 980
TX760B TX860B
TX870B TX970B

801 802 803 804 805 806 807 808 813 814 815 816 817 821 822 823 824 825 831
832 833 834 841 842 843 844 845 851 852 853 854 855 921 922 923 931 932

73006C01.1

6199042M3

1

Jan-06

Dipper
Balancier
Balancín

Extendahoe
Extendahoe
Extendahoe

JCB Bucket
Godet JCB
Cuchara JCB

C-73006-01.1-A

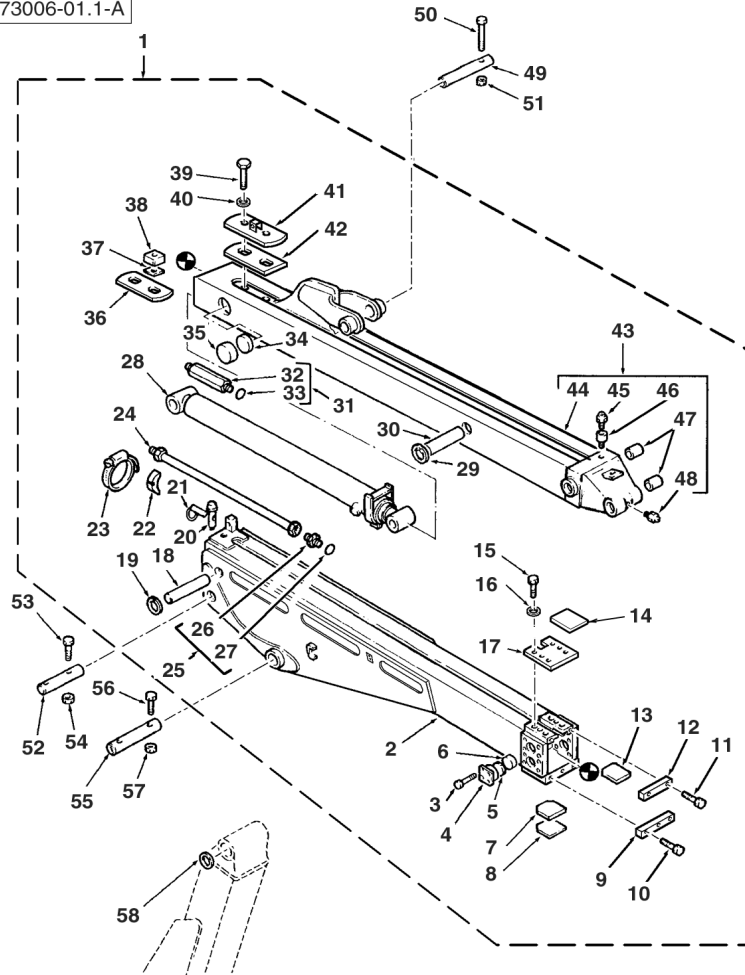

34	3502477M1	1	(E) 2,0 mm	X	Shim	Cale	Calce
35	3502473M2	1	(A) Inner	2	Pad, Wear	Patin d'usure	Patín de desgaste
36	6102559M1	1	(A) Torque Figures Lower	1	Pad, Wear	Patin d'usure	Patín de desgaste
37	3501975M2	1	1,0 mm	2	Shim	Cale	Calce
37	3502975M2	1	Top 2,0 mm	2	Shim	Cale	Calce
37	3502976M2	1	Bottom 3,0 mm	2	Shim	Cale	Calce
38	3501655M2	1		2	Spacer	Entretoise	Traviesa
39	3517491M1	1	(A) M24 x 90	2	Screw	Vis	Tornillo
40	896-11024	1	26 x 44 x 5 mm	2	Washer	Rondelle	Arandela
41	6102519M91	1		1	Plate	Plaque	Placa
42	6102518M1	1	(A) Upper	1	Pad, Wear	Patin d'usure	Patín de desgaste
43	6108789M91	1		1	Extension Assy	Ensemble de rallonge	Extensión, Conj.
44		43	Ref. 43	1	Body	Corps	Cuerpo
45	339608X1	43		1	Fitting, Grease	Graisneur	Engrasador
46	3504012M1	43		1	Adaptor	Adaptateur	Adaptador
47	6106532M1	43		2	Bushing	Bague	Anillo
48	339608X1			1	Fitting, Grease	Graisneur	Engrasador
49	3522720M2		45 x 250 mm	1	Pin	Axe	Pasador
50	3501289M1		M10 x 110	1	Screw	Vis	Tornillo
51	1440329X1		M10	1	Nut, Lock	Écrou de blocage	Tuerca de retención
52	3522693M2		45 x 310 mm	1	Pin	Axe	Pasador
53	3501289M1		M10 x 110	2	Screw	Vis	Tornillo
54	1440329X1		M10	2	Nut, Lock	Écrou de blocage	Tuerca de retención
55	3522693M2		45 x 310 mm	1	Pin	Axe	Pasador
56	3501289M1		M10 x 110	2	Screw	Vis	Tornillo
57	1440329X1		M10	2	Nut, Lock	Écrou de blocage	Tuerca de retención
58	3501027M1			2	Washer	Rondelle	Arandela
NI	6193766M91		(B)	1	Kit, Parts	Lot de pièces	Juego de piezas
NI	6193768M91		(D)	1	Kit, Parts	Lot de pièces	Juego de piezas
NI	3510860M91		(F)	1	Kit, Shim	Jeu de cales	Juego de calces

A Included in kit marked (B)
Inclus dans jeu marqué (B)
Incluido en juego marcado (B)

C Included in kit marked (D)
Inclus dans jeu marqué (D)
Incluido en juego marcado (D)

E Included in kit marked (F)
Inclus dans jeu marqué (F)
Incluido en juego marcado (F)

B Contains items marked (A)
Comprend les pièces marquées (A)
Incluye las piezas marcadas (A)

D Contains items marked (C)
Comprend les pièces marquées (C)
Incluye las piezas marcadas (C)

F Contains items marked (E)
Comprend les pièces marquées (E)
Incluye las piezas marcadas (E)



820 860 880 970 980
TX760B TX860B
TX870B TX970B

801 802 803 804 805 806 807 808 813 814 815 816 817 821 822 823 824 825 831
832 833 834 841 842 843 844 845 851 852 853 854 855 921 922 923 931 932

73006C01.1

6199042M3

1

Jan-06

Dipper
Balancier
Balancín

Extendahoe
Extendahoe
Extendahoe

Cylinder
Cylindre
Cilindro

C-73006-02.1-A

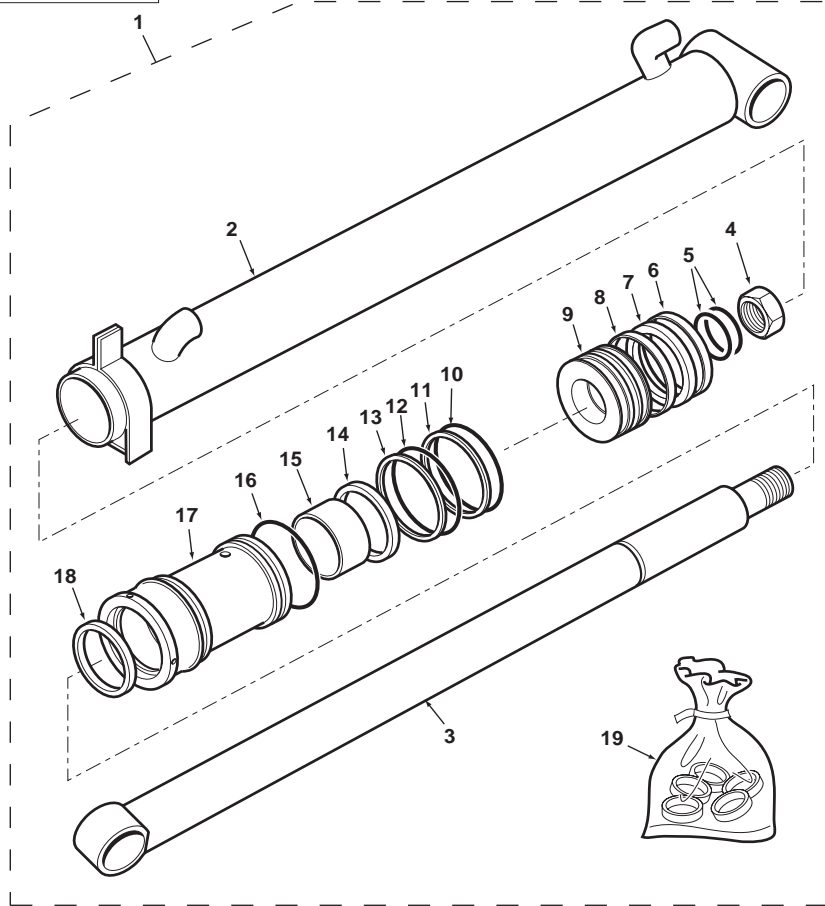

1	5000127M91		73006C01.1 28	1	Cylinder Assy	Ensemble de vérin	Gato, Conj.
2	5003920M91	1		1	Cylinder	Cylindre	Cilindro
3	5005266M91	1		1	Piston, Cylinder	Piston de vérin	Pistón de gato
4	1607689M1	1		1	Nut, Lock	Écrou de blocage	Tuerca de retención
5	1748324M1	1 (A)		2	O-Ring	Joint torique	Junta de tipo O
6	3487078M1	1		1	Ring	Anneau	Aro
7	3443573M2	1 (A)		1	Seal	Joint	Junta
8	3487078M1	1 (A)		1	Ring	Anneau	Aro
9	5003929M1	1		1	Piston	Piston	Pistón
10	1442891X1	1 (A)		1	O-Ring	Joint torique	Junta de tipo O
11	5001306M1	1 (A)		1	Ring, Backup	Contre-joint	ContraJunta
12	1441120X1	1 (A)		1	O-Ring	Joint torique	Junta de tipo O
13	1881527M1	1 (A)		1	Ring	Anneau	Aro
14	3485976M1	1 (A)		1	Seal	Joint	Junta
15	5001605M1	1		1	Bearing	Coussinet	Cojinete
16	3487585M1	1 (A)		1	O-Ring	Joint torique	Junta de tipo O
17	5004084M91	1		1	Bearing	Coussinet	Cojinete
18	1605446M1	1 (A)		1	Wiper	Racleur	Raspador, Escobilla
19	5005362M91		(B)	X	Kit, Seal	Pochette de joints	Juego de juntas

A Included in kit marked (B)
Inclus dans jeu marqué (B)
Incluido en juego marcado (B)

B Contains items marked (A)
Comprend les pièces marquées (A)
Incluye las piezas marcadas (A)



820 860 880 970 980
TX760B TX860B
TX870B TX970B

801 802 803 804 805 806 807 808 813 814 815 816 817 821 822 823 824 825 831
832 833 834 841 842 843 844 845 851 852 853 854 855 921 922 923 931 932

73006C02.1

6199042M3

1

Jan-06

Dipper
Balancier
Balancín

Standard
Standard
Estándar

AC-73001-01.1-A

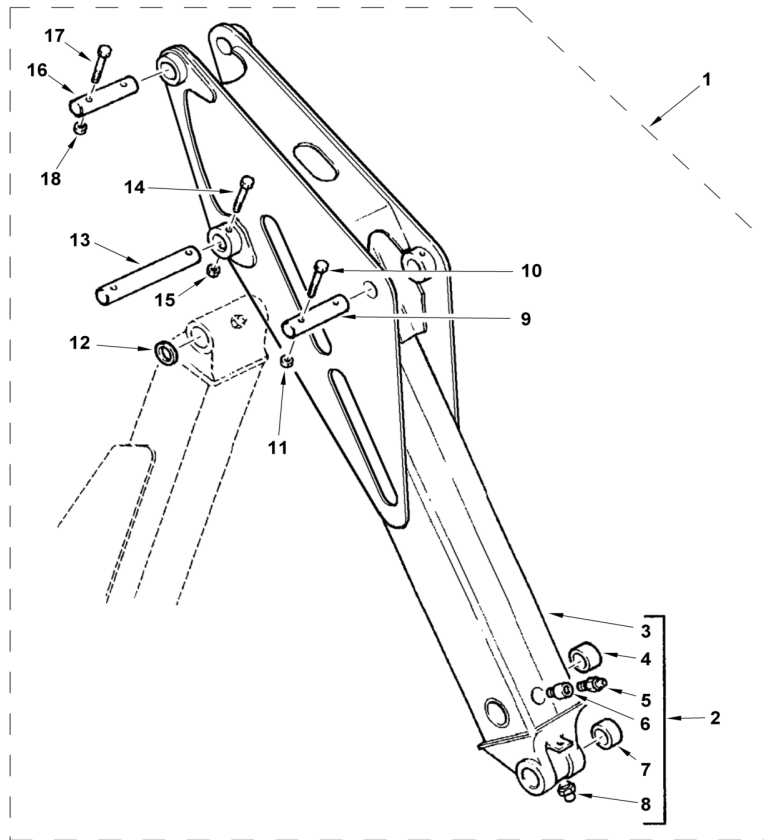

1	ACC15A		Std Dipper & Linkage	1	Accessory code	Code accessoire	Código accesorio
2	6100677M93	1		1	Dipperstick Assy	Ensemble de balancier	Balancín, Conj.
3		2	 Ref. 2	1	Dipper	En butte	Balancín
4	3500009M3	2		2	Bushing	Bague	Anillo
5	339608X1	2		1	Fitting, Grease	Graisseur	Engrasador
6	3504012M1	2		1	Adaptor	Adaptateur	Adaptador
7	3500009M3	2		2	Bushing	Bague	Anillo
8	339608X1	2		1	Fitting, Grease	Graisseur	Engrasador
9	3522694M2	1	45 x 230 mm	1	Pin	Axe	Pasador
10	3501289M1	1	M10 x 110	1	Screw	Vis	Tornillo
11	1440329X1	1	M10	1	Nut, Lock	Écrou de blocage	Tuerca de retención
12	3501027M1	1		2	Washer	Rondelle	Arandela
13	3522693M2	1	45 x 310 mm	1	Pin	Axe	Pasador
14	3501289M1	1	M10 x 110	2	Screw	Vis	Tornillo
15	1440329X1	1	M10	2	Nut, Lock	Écrou de blocage	Tuerca de retención
16	3522693M2	1	45 x 310 mm	1	Pin	Axe	Pasador
17	3501289M1	1	M10 x 110	2	Screw	Vis	Tornillo
18	1440329X1	1	M10	2	Nut, Lock	Écrou de blocage	Tuerca de retención



820 860 880 970 980
TX760B TX860B
TX870B TX970B

801 802 803 804 805 806 807 808 809 810 811 812 813 814 815 816 817 821 822
823 824 825 831 832 833 834 841 842 843 844 845 851 852 853 854 855 921 922
923 931 932

73001AC01.1

6199042M3

1

Jan-06

Dipper
Balancier
Balancín

Standard
Standard
Estándar

C-73001-01.1-A

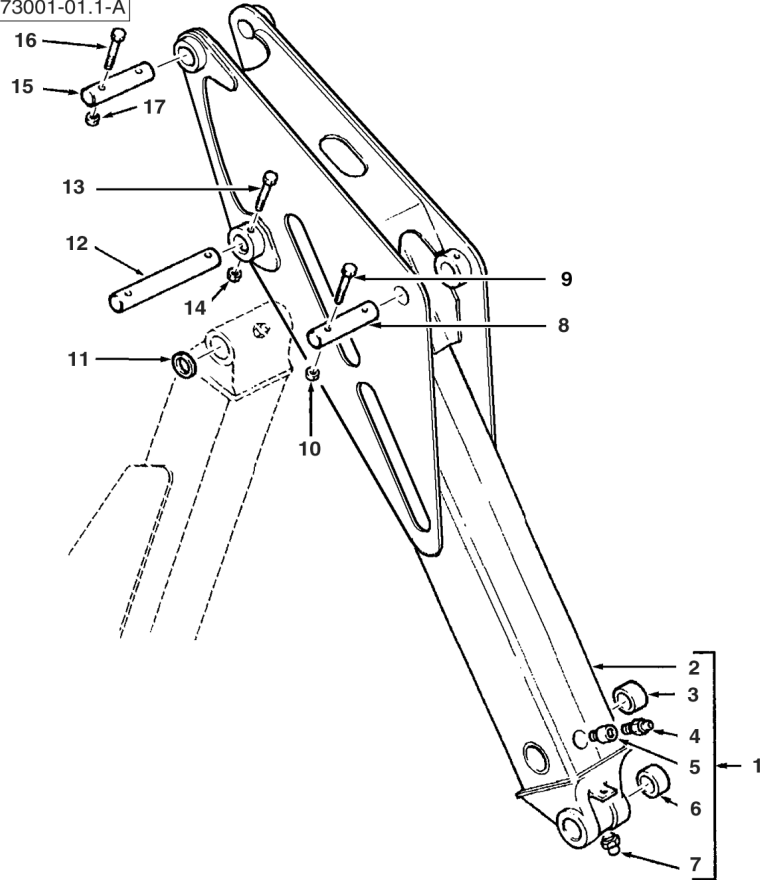

1	6100677M93		1	Dipperstick Assy	Ensemble de balancier	Balancín, Conj.
2		1	▶ Ref. 1	Dipper	En butte	Balancín
3	3500009M3	1		Bushing	Bague	Anillo
4	339608X1	1		Fitting, Grease	Graisseur	Engrasador
5	3504012M1	1		Adaptor	Adaptateur	Adaptador
6	3500009M3	1		Bushing	Bague	Anillo
7	339608X1	1		Fitting, Grease	Graisseur	Engrasador
8	3522694M2	45 x 230 mm	1	Pin	Axe	Pasador
9	3501289M1	M10 x 110	1	Screw	Vis	Tornillo
10	1440329X1	M10	1	Nut, Lock	Écrou de blocage	Tuerca de retención
11	3501027M1		2	Washer	Rondelle	Arandela
12	3522693M2	45 x 310 mm	1	Pin	Axe	Pasador
13	3501289M1	M10 x 110	2	Screw	Vis	Tornillo
14	1440329X1	M10	2	Nut, Lock	Écrou de blocage	Tuerca de retención
15	3522693M2	45 x 310 mm	1	Pin	Axe	Pasador
16	3501289M1	M10 x 110	2	Screw	Vis	Tornillo
17	1440329X1	M10	2	Nut, Lock	Écrou de blocage	Tuerca de retención



820 860 880 970 980
TX760B TX860B
TX870B TX970B

801 802 803 804 805 806 807 808 809 810 811 812 813 814 815 816 817 821 822
823 824 825 831 832 833 834 841 842 843 844 845 851 852 853 854 855 921 922
923 931 932

73001C01.1

6199042M3

1

Jan-06

Dipper
Balancier
Balancín

Standard
Standard
Estándar

Case Bucket
Godet Case
Cuchara de superficie

AC-73003-01.1-A

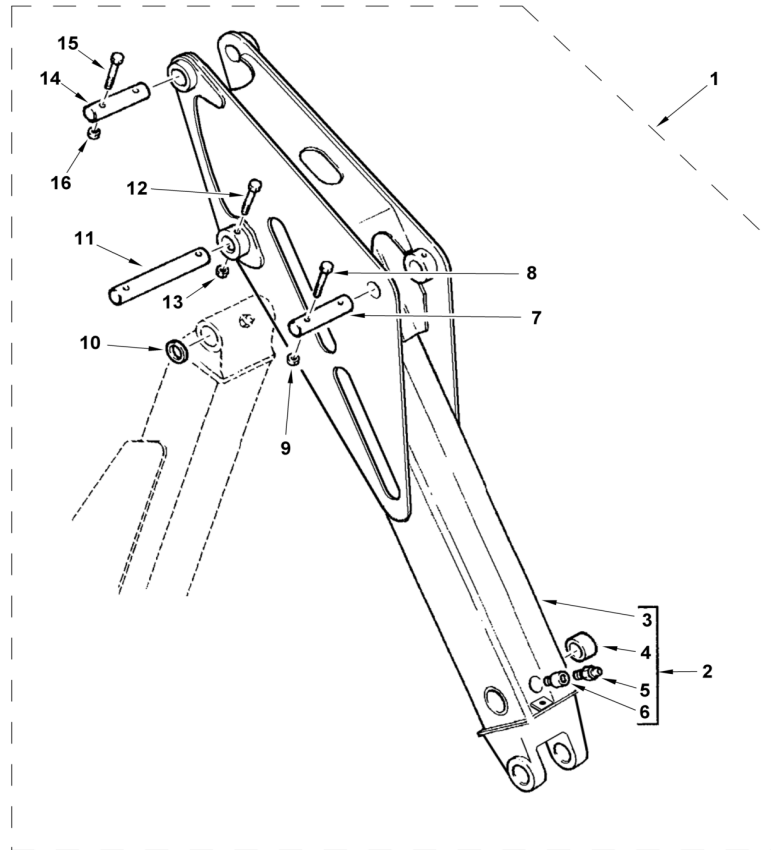

1	ACC16A		Case Dipper & Linkage	1	Accessory code	Code accessoire	Código accesorio
2	6100818M93	1		1	Dipperstick Assy	Ensemble de balancier	Balancín, Conj.
3		2	 Ref. 2	1	Dipper	En butte	Balancín
4	3500009M3	2		2	Bushing	Bague	Anillo
5	339608X1	2		1	Fitting, Grease	Graisseur	Engrasador
6	3504012M1	2		1	Adaptor	Adaptateur	Adaptador
7	3522694M2	1	45 x 230 mm	1	Pin	Axe	Pasador
8	3501289M1	1	M10 x 110	1	Screw	Vis	Tornillo
9	1440329X1	1	M10	1	Nut, Lock	Écrou de blocage	Tuerca de retención
10	3501027M1	1		2	Washer	Rondelle	Arandela
11	3522693M2	1	45 x 310 mm	1	Pin	Axe	Pasador
12	3501289M1	1	M10 x 110	2	Screw	Vis	Tornillo
13	1440329X1	1	M10	2	Nut, Lock	Écrou de blocage	Tuerca de retención
14	3522693M2	1	45 x 310 mm	1	Pin	Axe	Pasador
15	3501289M1	1	M10 x 110	2	Screw	Vis	Tornillo
16	1440329X1	1	M10	2	Nut, Lock	Écrou de blocage	Tuerca de retención



820 860 880 970 980
TX760B TX860B
TX870B TX970B

801 802 803 804 805 806 807 808 809 810 811 812 813 814 815 816 817 821 822
823 824 825 831 832 833 834 841 842 843 844 845 851 852 853 854 855 921 922
923 931 932

73003AC01.1

6199042M3

1

Jan-06

Dipper
Balancier
Balancín

Standard
Standard
Estándar

Case Bucket
Godet Case
Cuchara de superficie

C-73003-01.1-A

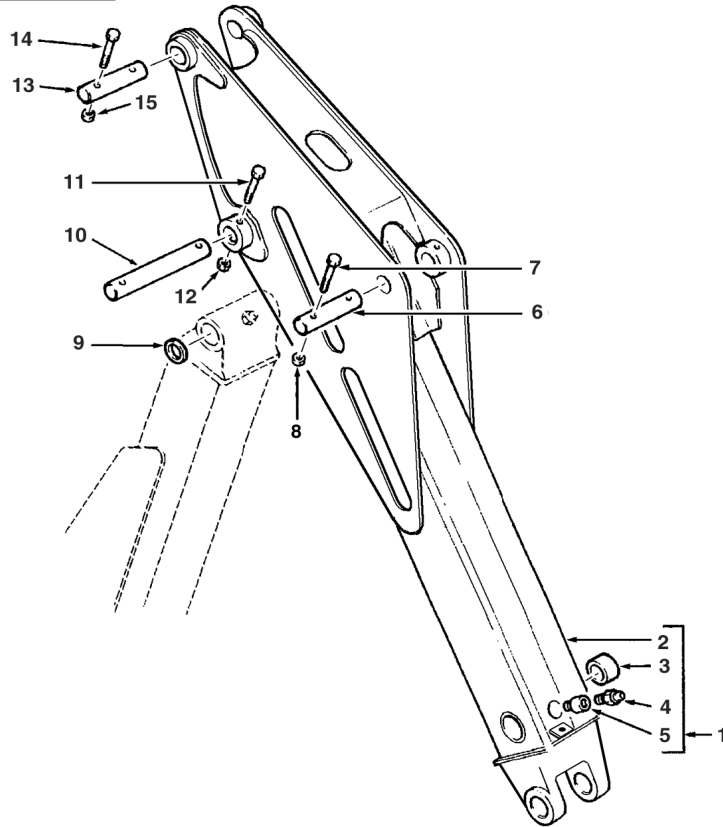

1	6100818M93		1	Dipperstick Assy	Ensemble de balancier	Balancín, Conj.
2		1	▶ Ref. 1	Dipper	En butte	Balancín
3	3500009M3	1		Bushing	Bague	Anillo
4	339608X1	1		Fitting, Grease	Graisseur	Engrasador
5	3504012M1	1		Adaptor	Adaptateur	Adaptador
6	3522694M2	45 x 230 mm	1	Pin	Axe	Pasador
7	3501289M1	M10 x 110	1	Screw	Vis	Tornillo
8	1440329X1	M10	1	Nut, Lock	Écrou de blocage	Tuerca de retención
9	3501027M1		2	Washer	Rondelle	Arandela
10	3522693M2	45 x 310 mm	1	Pin	Axe	Pasador
11	3501289M1	M10 x 110	2	Screw	Vis	Tornillo
12	1440329X1	M10	2	Nut, Lock	Écrou de blocage	Tuerca de retención
13	3522693M2	45 x 310 mm	1	Pin	Axe	Pasador
14	3501289M1	M10 x 110	2	Screw	Vis	Tornillo
15	1440329X1	M10	2	Nut, Lock	Écrou de blocage	Tuerca de retención



820 860 880 970 980
TX760B TX860B
TX870B TX970B

801 802 803 804 805 806 807 808 809 810 811 812 813 814 815 816 817 821 822
823 824 825 831 832 833 834 841 842 843 844 845 851 852 853 854 855 921 922
923 931 932

73003C01.1

6199042M3

1

Jan-06

Dipper
Balancier
Balancín

Standard
Standard
Estándar

JCB Bucket
Godet JCB
Cuchara JCB

C-73005-01.1-A

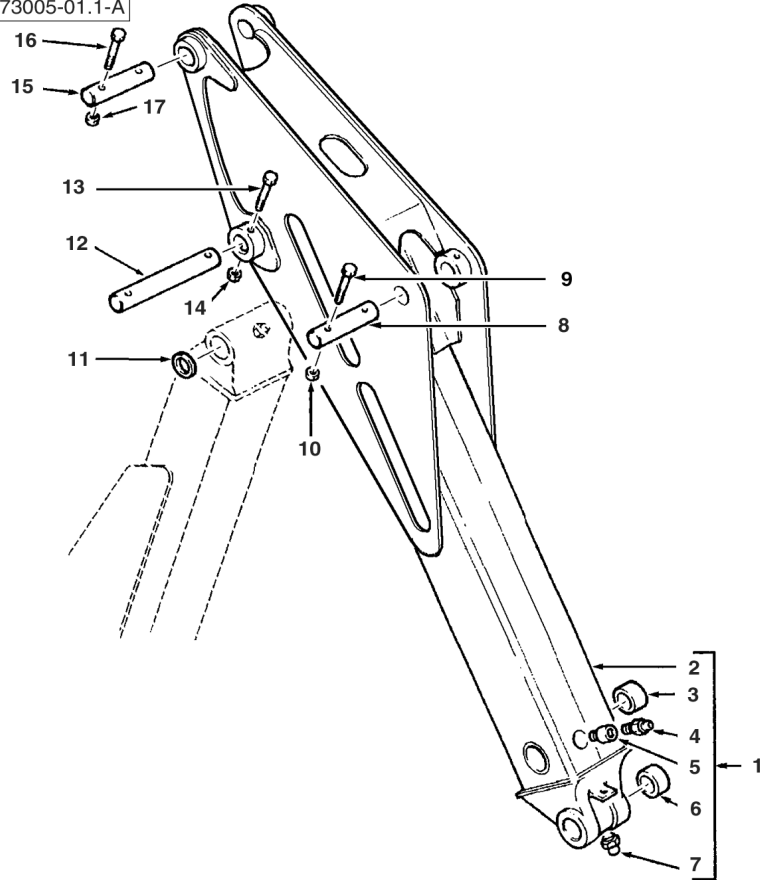

1	6108840M91		1	Dipperstick Assy	Ensemble de balancier	Balancín, Conj.
2		1	▶ Ref. 1	Dipper	En butte	Balancín
3	3500009M3	1		Bushing	Bague	Anillo
4	339608X1	1		Fitting, Grease	Graisseur	Engrasador
5	3504012M1	1		Adaptor	Adaptateur	Adaptador
6	3500009M3	1		Bushing	Bague	Anillo
7	339608X1	1		Fitting, Grease	Graisseur	Engrasador
8	3522694M2	45 x 230 mm	1	Pin	Axe	Pasador
9	3501289M1	M10 x 110	1	Screw	Vis	Tornillo
10	1440329X1	M10	1	Nut, Lock	Écrou de blocage	Tuerca de retención
11	3501027M1		2	Washer	Rondelle	Arandela
12	3522693M2	45 x 310 mm	1	Pin	Axe	Pasador
13	3501289M1	M10 x 110	2	Screw	Vis	Tornillo
14	1440329X1	M10	2	Nut, Lock	Écrou de blocage	Tuerca de retención
15	3522693M2	45 x 310 mm	1	Pin	Axe	Pasador
16	3501289M1	M10 x 110	2	Screw	Vis	Tornillo
17	1440329X1	M10	2	Nut, Lock	Écrou de blocage	Tuerca de retención



820 860 880 970 980
TX760B TX860B
TX870B TX970B

801 802 803 804 805 806 807 808 813 814 815 816 817 821 822 823 824 825 831
832 833 834 841 842 843 844 845 851 852 853 854 855 921 922 923 931 932

73005C01.1

6199042M3

1

Jan-06

Less Dipper
Sans balancier
Sin balancin

C-73007-01.1-A

1	356447X1	7/8	2	Plug, Blank-Off	Obturateur	Obturador
---	----------	-----	---	-----------------	------------	-----------

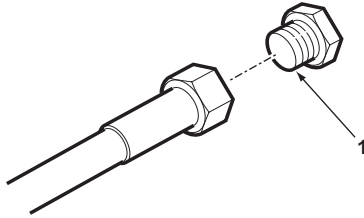

820 860 880 970
TX760B TX860B
TX870B

801 802 803 804 805 806 807 808 809 810 811 812 813 814 815 816 817 821 822
823 824 825 831 832 833 834 841 842 843 851 853 854 921 922 923

73007C01.1

6199042M3

1

Jan-06

Stabiliser Controls
Commandes Stabilisateurs
Mandos de estabilizadores

C-79005-01.1-A

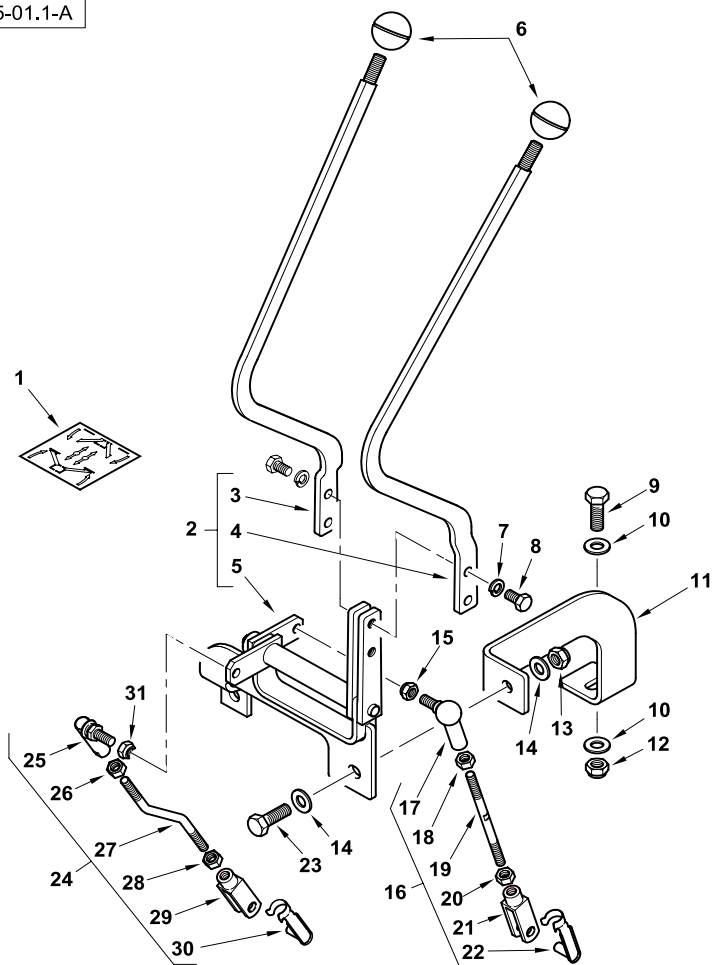

1	6106158M1			1	Decal	Adhésif	Adhesivo
2	6111092M91			1	Lever, Control	Levier de commande	Palanca de mando
3	6111088M91	2	▶	1	Lever Assy	Ensemble de levier	Palanca, Conj.
4	6111087M91	2	◀	1	Lever Assy	Ensemble de levier	Palanca, Conj.
5		2	▶ Ref. 2	1	Bracket	Patte de fixation	Pata de fijación
6	3517899M1			2	Knob	Boule	Bola
7	339374X1	M8		4	Washer, Lock	Rondelle de blocage	Arandela de freno
8	339124X1	M8 x 16		4	Screw	Vis	Tornillo
9	3009493X1	M10 x 30		1	Bolt	Boulon	Perno
10	390734X1	M10		2	Washer	Rondelle	Arandela
11	6111097M1			1	Bracket Assy	Ensemble chaise palier	Cuchara, Conj.
12	1440329X1	M10		1	Nut, Lock	Écrou de blocage	Tuerca de retención
13	1440329X1	M10		2	Nut, Lock	Écrou de blocage	Tuerca de retención
14	390734X1	M10		4	Washer	Rondelle	Arandela
15	394367X1	M8		1	Nut, Lock	Écrou de blocage	Tuerca de retención
16	6111110M91			1	Rod Assy	Ensemble tringlerie	Tirantes, Conj.
17	3517518M1	16		1	Ball Joint	Rotule	Rotula
18	339169X1	16	M8	1	Nut	Écrou	Tuerca
19	6111112M1	16		1	Rod	Tringle	Vástago
20	3519650M1	16	M8 LH Thread	1	Nut	Écrou	Tuerca
21	3519590M1	16	LH Thread	1	Clevis	Chape	Brida
22	3520666M1	16		1	Pin, Clevis	Axe de chape	Eje de brida
23	3009493X1	M10 x 30		2	Bolt	Boulon	Perno
24	6111111M91			1	Rod Assy	Ensemble tringlerie	Tirantes, Conj.
25	3519589M1	24		1	Ball Joint	Rotule	Rotula
26	339169X1	24	M8	1	Nut	Écrou	Tuerca
27	6111113M1	24		1	Rod	Tringle	Vástago
28	3519650M1	24	M8 LH Thread	1	Nut	Écrou	Tuerca
29	3519590M1	24	LH Thread	1	Clevis	Chape	Brida
30	3520666M1	24		1	Pin, Clevis	Axe de chape	Eje de brida
31	394367X1	M8		1	Nut, Lock	Écrou de blocage	Tuerca de retención



880
 TX760B TX860B
 TX870B

832 834 842 844 852 854

79005C01.1

6199042M3

1

Jan-06

Stabiliser Controls
Commandes Stabilisateurs
Mandos de estabilizadores

C-79006-01.1-A

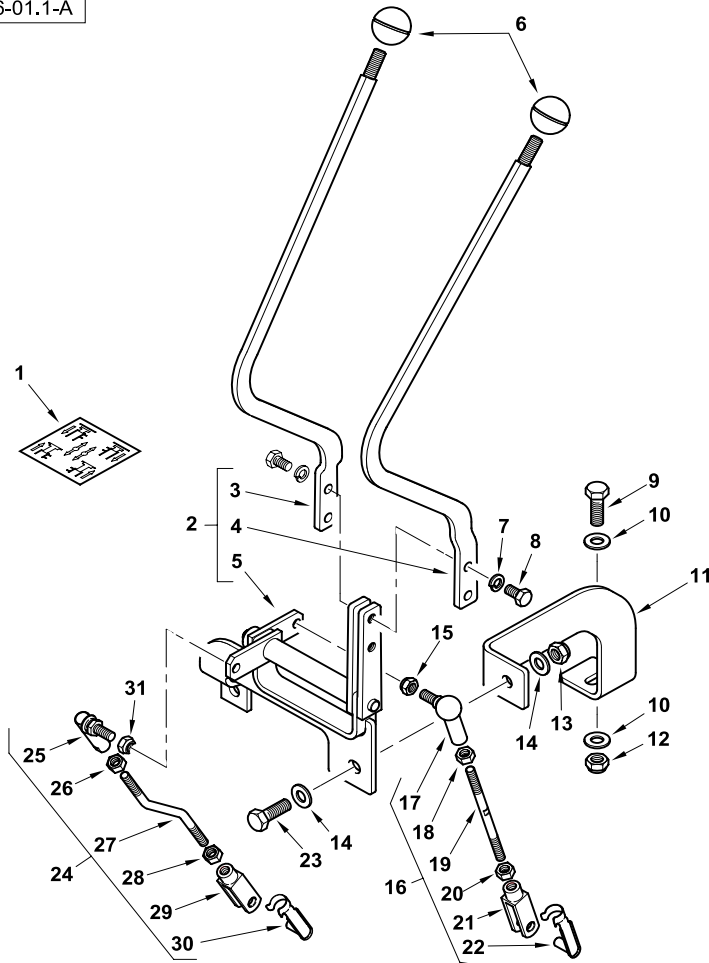

1	6106157M1		1	Decal	Adhésif	Adhesivo
2	6111092M91		1	Lever, Control	Levier de commande	Palanca de mando
3	6111088M91	2	▶	Lever Assy	Ensemble de levier	Palanca, Conj.
4	6111087M91	2	◀	Lever Assy	Ensemble de levier	Palanca, Conj.
5		2	➡ Ref. 2	Bracket	Patte de fixation	Pata de fijación
6	3517899M1		2	Knob	Boule	Bola
7	339374X1	M8	4	Washer, Lock	Rondelle de blocage	Arandela de freno
8	339124X1	M8 x 16	4	Screw	Vis	Tornillo
9	3009493X1	M10 x 30	1	Bolt	Boulon	Perno
10	390734X1	M10	2	Washer	Rondelle	Arandela
11	6111097M1		1	Bracket Assy	Ensemble chaise palier	Cuchara, Conj.
12	1440329X1	M10	1	Nut, Lock	Écrou de blocage	Tuerca de retención
13	1440329X1	M10	2	Nut, Lock	Écrou de blocage	Tuerca de retención
14	390734X1	M10	4	Washer	Rondelle	Arandela
15	394367X1	M8	1	Nut, Lock	Écrou de blocage	Tuerca de retención
16	6111110M91		1	Rod Assy	Ensemble tringlerie	Tirantes, Conj.
17	3517518M1	16	1	Ball Joint	Rotule	Rotula
18	339169X1	16	M8	1	Nut	Tuerca
19	6111112M1	16	1	Rod	Tringle	Vástago
20	3519650M1	16	M8 LH Thread	1	Nut	Tuerca
21	3519590M1	16	LH Thread	1	Clevis	Chape
22	3520666M1	16	1	Pin, Clevis	Axe de chape	Eje de brida
23	3009493X1	M10 x 30	2	Bolt	Boulon	Perno
24	6111111M91		1	Rod Assy	Ensemble tringlerie	Tirantes, Conj.
25	3519589M1	24	1	Ball Joint	Rotule	Rotula
26	339169X1	24	M8	1	Nut	Tuerca
27	6111113M1	24	1	Rod	Tringle	Vástago
28	3519650M1	24	M8 LH Thread	1	Nut	Tuerca
29	3519590M1	24	LH Thread	1	Clevis	Chape
30	3520666M1	24	1	Pin, Clevis	Axe de chape	Eje de brida
31	394367X1	M8	1	Nut, Lock	Écrou de blocage	Tuerca de retención



880
 TX760B TX860B
 TX870B

832 834 842 844 852 854

79006C01.1

6199042M3

1

Jan-06

Stabiliser Controls
Commandes Stabilisateurs
Mandos de estabilizadores

Centremount Digger
Montage de Pelle Central
Excavadora de montaje central

C-79002-01.1-A

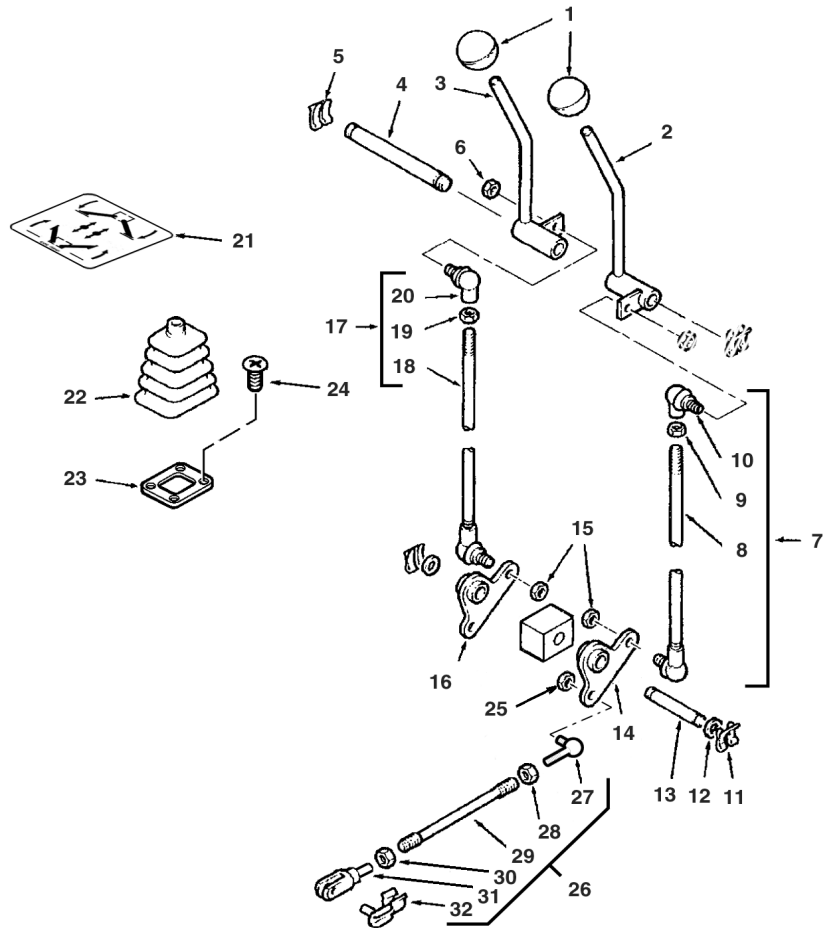

1	3517899M1		2	Knob	Boule	Bola
2	6100825M92	◀	1	Lever, Control	Levier de commande	Palanca de mando
3	6100826M92	▶	14	Lever Assy	Ensemble de levier	Palanca, Conj.
4	3521567M2		1	Pin	Axe	Pasador
5	3521460M1		2	Clip	Clip	Clip
6	394367X1	M8	2	Nut, Lock	Écrou de blocage	Tuerca de retención
7	6100874M91		1	Rod Assy	Ensemble tringlerie	Tirantes, Conj.
8		7 ▶ Ref. 7	1	Rod	Tringle	Vástago
9	392309X1	7 M8	1	Nut	Écrou	Tuerca
10	3520655M1	7	1	Ball Joint	Rotule	Rotula
11	3521461M1	M10	2	Clip	Clip	Clip
12	390734X1	M10	2	Washer	Rondelle	Arandela
13	6108468M1		1	Pin	Axe	Pasador
14	6107713M1		1	Pivot	Pivot	Pivote
15	394367X1	M8	2	Nut, Lock	Écrou de blocage	Tuerca de retención
16	6107713M1		1	Pivot	Pivot	Pivote
17	6100873M91		1	Rod Assy	Ensemble tringlerie	Tirantes, Conj.
18		17 ▶ Ref. 17	1	Rod	Tringle	Vástago
19	392309X1	17 M8	1	Nut	Écrou	Tuerca
20	3520655M1	17	1	Ball Joint	Rotule	Rotula
21	6106158M1		1	Decal	Adhésif	Adhesivo
22	6109925M1		2	Boot	Soufflet	Fuelle
23	6101343M2		2	Plate	Plaque	Placa
24	3521303M3		8	Fastener	Attache	Enganche
25	339169X1	M8	2	Nut	Écrou	Tuerca
26	6106905M91		2	Rod Assy	Ensemble tringlerie	Tirantes, Conj.
27	3517518M1	26	1	Ball Joint	Rotule	Rotula
28	339169X1	26 M8	1	Nut	Écrou	Tuerca
29		26 ▶ Ref. 26	1	Rod	Tringle	Vástago
30	3519650M1	26 M8 LH Thread	1	Nut	Écrou	Tuerca
31	3519590M1	26 LH Thread	1	Clevis	Chape	Brida
32	3520666M1	26	1	Pin, Clevis	Axe de chape	Eje de brida



820 860 880 970 980
 TX760B TX860B
 TX870B TX970B

801 803 809 811 813 815 816 821 823 824 831 841 843 851 853 922 923 932

79002C01.1

6199042M3

1

Jan-06

Stabiliser Controls
Commandes Stabilisateurs
Mandos de estabilizadores

Centremount Digger
Montage de Pelle Central
Excavadora de montaje central

C-79002-02.1-A

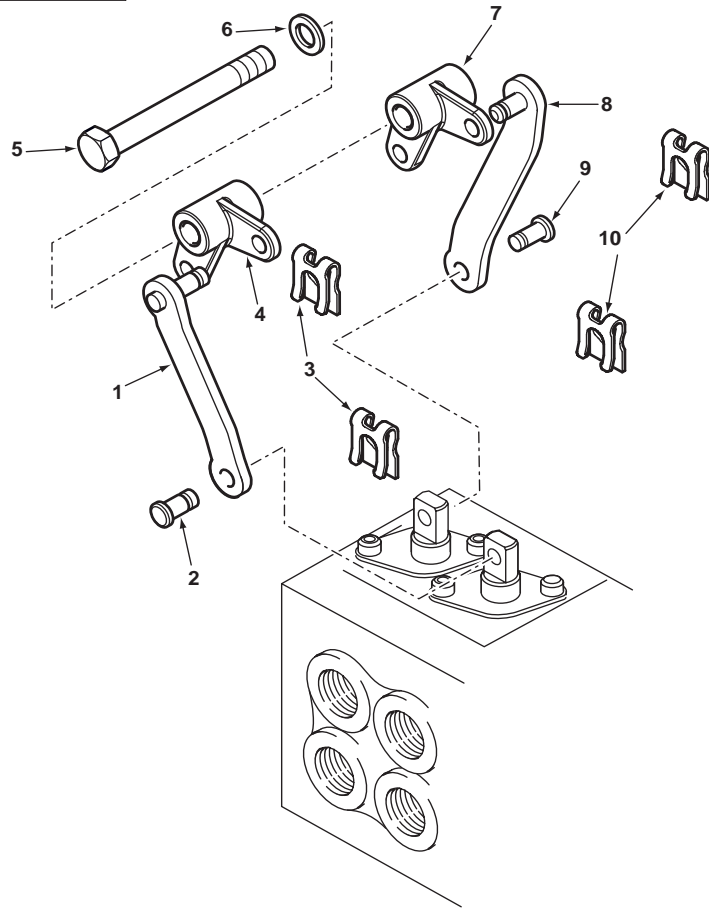

1	6106626M92		1	Link Assy	Ensemble de maillon	Eslabón, Conj.
2	6102816M1		1	Pin, Clevis	Axe de chape	Eje de brida
3	3516322M1		2	Clip	Clip	Clip
4	6108530M1		1	Lever Assy	Ensemble de levier	Palanca, Conj.
5	3009518X1	M12 x 110	1	Bolt	Boulon	Perno
6	339369X1	M12	1	Washer, Lock	Rondelle de blocage	Arandela de freno
7	6108530M1		1	Lever Assy	Ensemble de levier	Palanca, Conj.
8	6106626M92		1	Link Assy	Ensemble de maillon	Eslabón, Conj.
9	6102816M1		1	Pin, Clevis	Axe de chape	Eje de brida
10	3516322M1		2	Clip	Clip	Clip



820 860 880 970 980
 TX760B TX860B
 TX870B TX970B

801 803 809 811 813 815 816 821 823 824 831 841 843 851 853 922 923 932

79002C02.1

6199042M3

1

Jan-06

**Stabiliser Controls
Commandes Stabilisateurs
Mandos de estabilizadores**

**Centremount Digger
Montage de Pelle Central
Excavadora de montaje central**

4 Post ROPS
4 Poteau ROPS
4 poste ROPS

C-79003-01.1-A

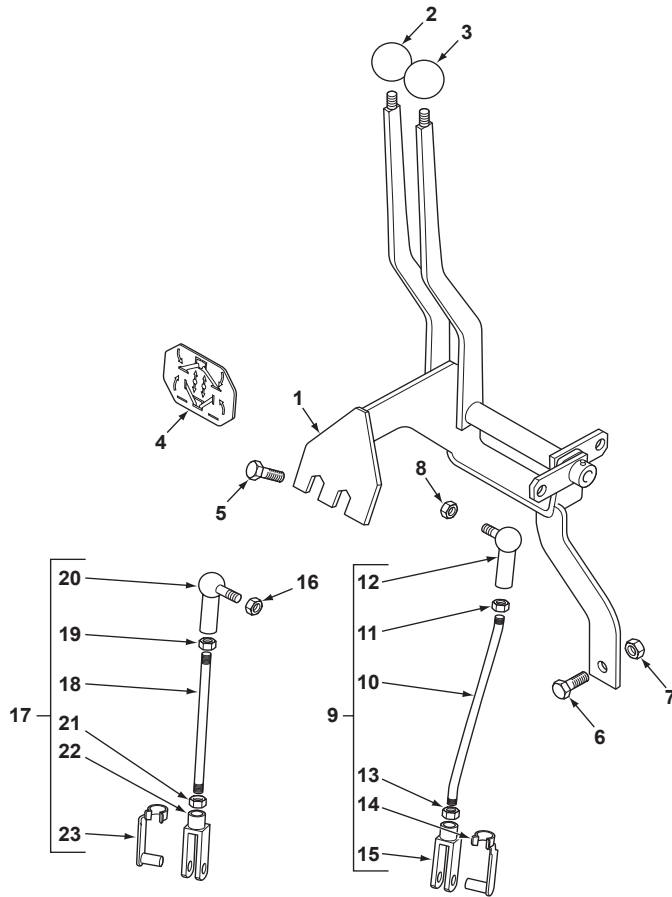

1	6109033M93		1	Lever Assy	Ensemble de levier	Palanca, Conj.
2	3517899M1		1	Knob	Boule	Bola
3	3517899M1		1	Knob	Boule	Bola
4	6106158M1		1	Decal	Adhésif	Adhesivo
5	339761X1	M8 x 25	2	Screw	Vis	Tornillo
6	3009493X1	M10 x 30	1	Bolt	Boulon	Perno
7	1440329X1	M10	1	Nut, Lock	Écrou de blocage	Tuerca de retención
8	394367X1	M8	1	Nut, Lock	Écrou de blocage	Tuerca de retención
9	6108430M92		1	Rod Assy	Ensemble tringlerie	Tirantes, Conj.
10		9	1	Ref. 9	Tringle	Vástago
11	339169X1	M8	1	Nut	Écrou	Tuerca
12	3517518M1	9	1	Ball Joint	Rotule	Rotula
13	3519650M1	9 M8 LH Thread	1	Nut	Écrou	Tuerca
14	3520666M1	9	1	Pin, Clevis	Axe de chape	Eje de brida
15	3520666M1	9	1	Pin, Clevis	Axe de chape	Eje de brida
16	394367X1	M8	1	Nut, Lock	Écrou de blocage	Tuerca de retención
17	6108429M91		1	Rod Assy	Ensemble tringlerie	Tirantes, Conj.
18		17	1	Ref. 17	Tringle	Vástago
19	339169X1	17 M8	1	Nut	Écrou	Tuerca
20	3517518M1	17	1	Ball Joint	Rotule	Rotula
21	3519650M1	17 M8 LH Thread	1	Nut	Écrou	Tuerca
22	3519590M1	17 LH Thread	1	Clevis	Chape	Brida
23	3520666M1	17	1	Pin, Clevis	Axe de chape	Eje de brida



820 860
TX760B TX860B
TX870B

802 804 810 812 814 816 822 824

79003C01.1

6199042M3

1

Jan-06

Stabiliser Controls
Commandes Stabilisateurs
Mandos de estabilizadores

Sideshift Digger
Montage de Pelle Latéral
Excavadora de montaje lateral

C-79001-01.1-A

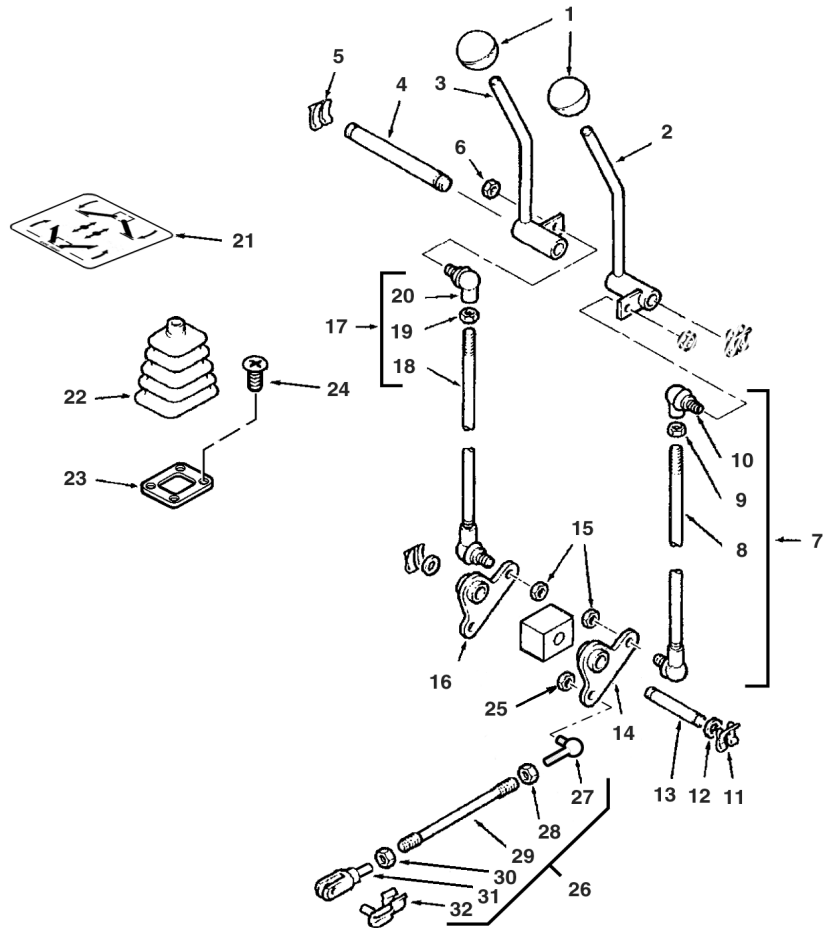

1	3517899M1		2	Knob	Boule	Bola
2	6100825M92	◀	1	Lever, Control	Levier de commande	Palanca de mando
3	6100826M92	▶	14	Lever Assy	Ensemble de levier	Palanca, Conj.
4	3521567M2		1	Pin	Axe	Pasador
5	3521460M1		2	Clip	Clip	Clip
6	394367X1	M8	2	Nut, Lock	Écrou de blocage	Tuerca de retención
7	6100874M91		1	Rod Assy	Ensemble tringlerie	Tirantes, Conj.
8		7 ▶ Ref. 7	1	Rod	Tringle	Vástago
9	392309X1	7 M8	1	Nut	Écrou	Tuerca
10	3520655M1	7	1	Ball Joint	Rotule	Rotula
11	3521461M1	M10	2	Clip	Clip	Clip
12	390734X1	M10	2	Washer	Rondelle	Arandela
13	6108468M1		1	Pin	Axe	Pasador
14	6107713M1		1	Pivot	Pivot	Pivote
15	394367X1	M8	2	Nut, Lock	Écrou de blocage	Tuerca de retención
16	6107713M1		1	Pivot	Pivot	Pivote
17	6100873M91		1	Rod Assy	Ensemble tringlerie	Tirantes, Conj.
18		17 ▶ Ref. 17	1	Rod	Tringle	Vástago
19	392309X1	17 M8	1	Nut	Écrou	Tuerca
20	3520655M1	17	1	Ball Joint	Rotule	Rotula
21	6106157M1		1	Decal	Adhésif	Adhesivo
22	6109925M1		2	Boot	Soufflet	Fuelle
23	6101343M2		2	Plate	Plaque	Placa
24	3521303M3		8	Fastener	Attache	Enganche
25	339169X1	M8	2	Nut	Écrou	Tuerca
26	6106905M91		2	Rod Assy	Ensemble tringlerie	Tirantes, Conj.
27	3517518M1	26	1	Ball Joint	Rotule	Rotula
28	339169X1	26 M8	1	Nut	Écrou	Tuerca
29		26 ▶ Ref. 26	1	Rod	Tringle	Vástago
30	3519650M1	26 M8 LH Thread	1	Nut	Écrou	Tuerca
31	3519590M1	26 LH Thread	1	Clevis	Chape	Brida
32	3520666M1	26	1	Pin, Clevis	Axe de chape	Eje de brida



820 860 880 970 980
 TX760B TX860B

805 806 807 808 817 825 833 845 855 921 931

79001C01.1

6199042M3

1

Jan-06

Stabiliser Controls
Commandes Stabilisateurs
Mandos de estabilizadores

Sideshift Digger
Montage de Pelle Latéral
Excavadora de montaje lateral

C-79001-02.1-A

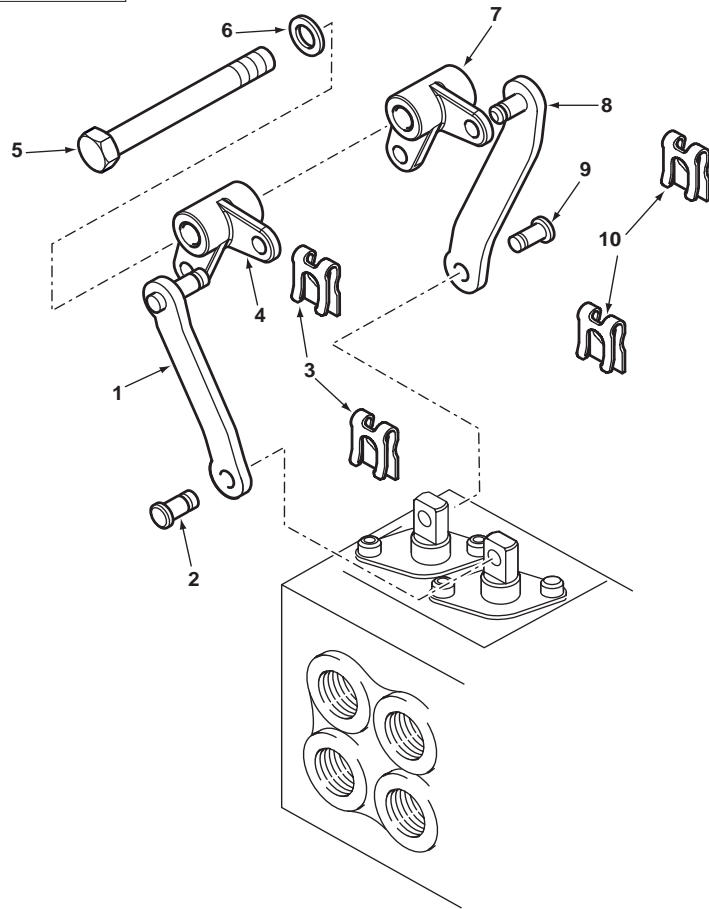

1	6106626M92		1	Link Assy	Ensemble de maillon	Eslabón, Conj.
2	6102816M1		1	Pin, Clevis	Axe de chape	Eje de brida
3	3516322M1		2	Clip	Clip	Clip
4	6108530M1		1	Lever Assy	Ensemble de levier	Palanca, Conj.
5	3009518X1	M12 x 110	1	Bolt	Boulon	Perno
6	339369X1	M12	1	Washer, Lock	Rondelle de blocage	Arandela de freno
7	6108530M1		1	Lever Assy	Ensemble de levier	Palanca, Conj.
8	6106626M92		1	Link Assy	Ensemble de maillon	Eslabón, Conj.
9	6102816M1		1	Pin, Clevis	Axe de chape	Eje de brida
10	3516322M1		2	Clip	Clip	Clip



820 860 880 970 980
 TX760B TX860B

805 806 807 808 817 825 833 845 855 921 931

79001C02.1

6199042M3

1

Jan-06

Stabiliser Controls
Commandes Stabilisateurs
Mandos de estabilizadores

Sideshift Digger
Montage de Pelle Latéral
Excavadora de montaje lateral

4 Post ROPS
 4 Poteau ROPS
 4 poste ROPS

C-79004-01.1-A

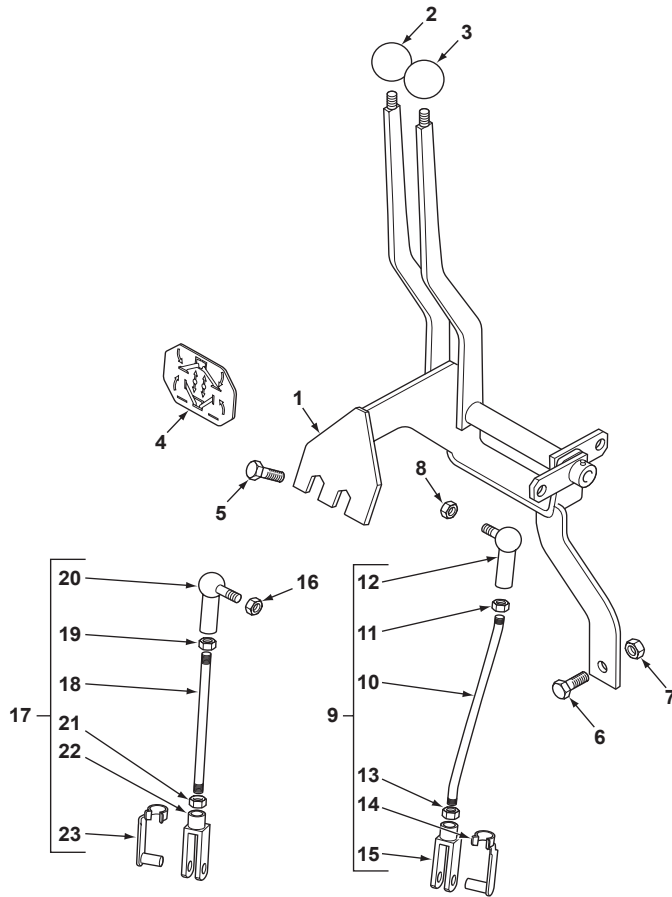

1	6109033M92		1	Lever Assy	Ensemble de levier	Palanca, Conj.
2	3517899M1		1	Knob	Boule	Bola
3	3517899M1		1	Knob	Boule	Bola
4	6106157M1		1	Decal	Adhésif	Adhesivo
5	339761X1	M8 x 25	2	Screw	Vis	Tornillo
6	3009493X1	M10 x 30	1	Bolt	Boulon	Perno
7	1440329X1	M10	1	Nut, Lock	Écrou de blocage	Tuerca de retención
8	394367X1	M8	1	Nut, Lock	Écrou de blocage	Tuerca de retención
9	6108430M92		1	Rod Assy	Ensemble tringlerie	Tirantes, Conj.
10		9	1	Rod	Tringle	Vástago
11	339169X1	M8	1	Nut	Écrou	Tuerca
12	3517518M1	9	1	Ball Joint	Rotule	Rotula
13	3519650M1	9 M8 LH Thread	1	Nut	Écrou	Tuerca
14	3520666M1	9	1	Pin, Clevis	Axe de chape	Eje de brida
15	3520666M1	9	1	Pin, Clevis	Axe de chape	Eje de brida
16	394367X1	M8	1	Nut, Lock	Écrou de blocage	Tuerca de retención
17	6108429M91		1	Rod Assy	Ensemble tringlerie	Tirantes, Conj.
18		17	1	Rod	Tringle	Vástago
19	339169X1	17 M8	1	Nut	Écrou	Tuerca
20	3517518M1	17	1	Ball Joint	Rotule	Rotula
21	3519650M1	17 M8 LH Thread	1	Nut	Écrou	Tuerca
22	3519590M1	17 LH Thread	1	Clevis	Chape	Brida
23	3520666M1	17	1	Pin, Clevis	Axe de chape	Eje de brida



820
TX760B

806 808

79004C01.1

6199042M3

1

Jan-06

E - Digger Swing System • Système de pivotement de la pelle • Sistema de oscilación de la excavadora

Digger Hydraulics - Sideshift	76036C07.1	Circuit Hydraulique Défonceuse - Montage de Pelle Latéral	Circuito hidráulico equipo retro - Excavadora de montaje horizontal
Digger Hydraulics - Sideshift	76036C08.1	Circuit Hydraulique Défonceuse - Montage de Pelle Latéral	Circuito hidráulico equipo retro - Excavadora de montaje horizontal
Digger Hydraulics - Sideshift	76036C09.1	Circuit Hydraulique Défonceuse - Montage de Pelle Latéral	Circuito hidráulico equipo retro - Excavadora de montaje horizontal
Digger Hydraulics - Sideshift	76037C01.1	Circuit Hydraulique Défonceuse - Montage de Pelle Latéral	Circuito hidráulico equipo retro - Excavadora de montaje horizontal
Digger Hydraulics - Sideshift	76037C02.1	Circuit Hydraulique Défonceuse - Montage de Pelle Latéral	Circuito hidráulico equipo retro - Excavadora de montaje horizontal
Digger Hydraulics - Sideshift	76037C03.1	Circuit Hydraulique Défonceuse - Montage de Pelle Latéral	Circuito hidráulico equipo retro - Excavadora de montaje horizontal
Digger Hydraulics - Sideshift	76037C04.1	Circuit Hydraulique Défonceuse - Montage de Pelle Latéral	Circuito hidráulico equipo retro - Excavadora de montaje horizontal
Digger Hydraulics - Sideshift	76037C05.1	Circuit Hydraulique Défonceuse - Montage de Pelle Latéral	Circuito hidráulico equipo retro - Excavadora de montaje horizontal
Digger Hydraulics - Sideshift	76037C06.1	Circuit Hydraulique Défonceuse - Montage de Pelle Latéral	Circuito hidráulico equipo retro - Excavadora de montaje horizontal
Digger Hydraulics - Sideshift	76037C07.1	Circuit Hydraulique Défonceuse - Montage de Pelle Latéral	Circuito hidráulico equipo retro - Excavadora de montaje horizontal
Digger Hydraulics - Sideshift	76037C08.1	Circuit Hydraulique Défonceuse - Montage de Pelle Latéral	Circuito hidráulico equipo retro - Excavadora de montaje horizontal
Digger Hydraulics - Sideshift	76037C09.1	Circuit Hydraulique Défonceuse - Montage de Pelle Latéral	Circuito hidráulico equipo retro - Excavadora de montaje horizontal
Digger Stabilisers - Centremount	70002C01.1	Stabilisateurs - Montage de Pelle Central	Estabilizadores - Excavadora de montaje central
Digger Stabilisers - Centremount	70002C02.1	Stabilisateurs - Montage de Pelle Central	Estabilizadores - Excavadora de montaje central
Digger Stabilisers - Centremount	70002C03.1	Stabilisateurs - Montage de Pelle Central	Estabilizadores - Excavadora de montaje central
Digger Stabilisers - Centremount	70002C04.1	Stabilisateurs - Montage de Pelle Central	Estabilizadores - Excavadora de montaje central
Digger Stabilisers - Centremount	70003C01.1	Stabilisateurs - Montage de Pelle Central	Estabilizadores - Excavadora de montaje central
Digger Stabilisers - Centremount	70003C02.1	Stabilisateurs - Montage de Pelle Central	Estabilizadores - Excavadora de montaje central
Digger Stabilisers - Centremount	70003C04.1	Stabilisateurs - Montage de Pelle Central	Estabilizadores - Excavadora de montaje central
Digger Stabilisers - Sideshift	70001C01.1	Stabilisateurs - Montage de Pelle Latéral	Estabilizadores - Excavadora de montaje horizontal
Digger Stabilisers - Sideshift	70001C02.1	Stabilisateurs - Montage de Pelle Latéral	Estabilizadores - Excavadora de montaje horizontal
Digger Stabilisers - Sideshift	70001C03.1	Stabilisateurs - Montage de Pelle Latéral	Estabilizadores - Excavadora de montaje horizontal
Digger Stabilisers - Sideshift	70004C01.1	Stabilisateurs - Montage de Pelle Latéral	Estabilizadores - Excavadora de montaje horizontal
Digger Stabilisers - Sideshift	70004C02.1	Stabilisateurs - Montage de Pelle Latéral	Estabilizadores - Excavadora de montaje horizontal
Digger Stabilisers - Sideshift	70004C03.1	Stabilisateurs - Montage de Pelle Latéral	Estabilizadores - Excavadora de montaje horizontal
Digger Stabilisers - Sideshift	70004C04.1	Stabilisateurs - Montage de Pelle Latéral	Estabilizadores - Excavadora de montaje horizontal
Digger Swing Pivot - Centremount	71002C01.1	Pivot d'orientation - Montage de Pelle Central	Pivote de orientación - Excavadora de montaje central
Digger Swing Pivot - Centremount	71002C02.1	Pivot d'orientation - Montage de Pelle Central	Pivote de orientación - Excavadora de montaje central
Digger Swing Pivot - Sideshift	71001C01.1	Pivot d'orientation - Montage de Pelle Latéral	Pivote de orientación - Excavadora de montaje horizontal
Digger Swing Pivot - Sideshift	71001C02.1	Pivot d'orientation - Montage de Pelle Latéral	Pivote de orientación - Excavadora de montaje horizontal
Hose Burst Kit.....	98039C01.1	Coffret de Éclatement de Tuyau	Juego de rotura de tubo flexible
Hose Burst Kit.....	98039C02.1	Coffret de Éclatement de Tuyau	Juego de rotura de tubo flexible
Hose Burst Kit.....	98040C01.1	Coffret de Éclatement de Tuyau	Juego de rotura de tubo flexible
Hose Burst Kit.....	98040C02.1	Coffret de Éclatement de Tuyau	Juego de rotura de tubo flexible



Digger Hydraulics
Circuit Hydraulique Défonceuse
Circuito hidráulico equipo retro

Centremount
Montage de Pelle Central
Excavadora de montaje central

Stabilizer Cylinder
Vérin de Stabilisateur
Gato de estabilizador

C-70003-03.1-A

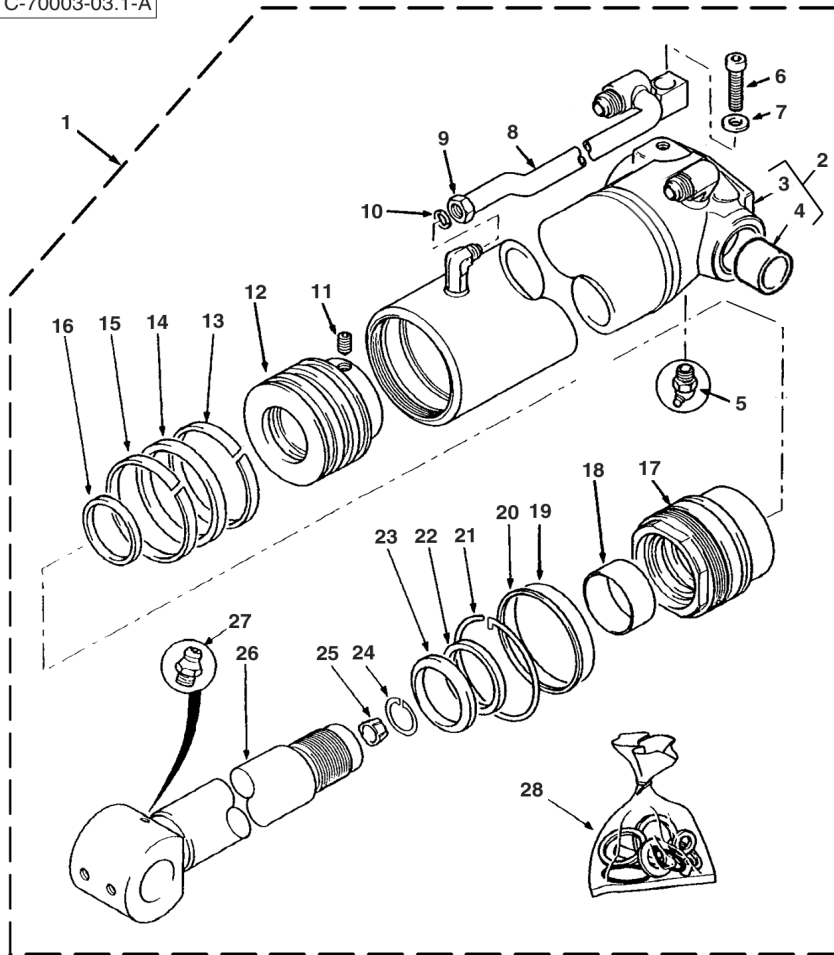

1	3622612M91	70003C01.1 7 70003C02.1 1	2	Cylinder Assy	Ensemble de vérin	Gato, Conj.
2	3624726M91	1	1	Tube, Cylinder	Cylindre de vérin	Cilindro de gato
3		2	1	Tube, Cylinder	Cylindre de vérin	Cilindro de gato
4	1606012M1	2	2	Bushing	Bague	Anillo
5	19575X	1	1	Fitting, Grease	Graisneur	Engrasador
6	3000258X1	1	1	Bolt	Boulon	Perno
7	390734X1	1	1	Washer	Rondelle	Arandela
8	3624727M91	1	1	Tube Assy	Tuyauterie	Conjunto de tubería
9	3624728M1	1	1	Nut	Écrou	Tuerca
10	3624729M1	1	1	Ring	Anneau	Aro
11	3402928M1	1	1	Screw	Vis	Tornillo
12	3484432M1	1	1	Piston, Cylinder	Piston de vérin	Pistón de gato
13	1033695M1	1 (A)	1	Ring	Anneau	Aro
14	5002310M1	1 (A)	1	Seal	Joint	Junta
15	1033695M1	1 (A)	1	Ring	Anneau	Aro
16	359185X1	1 (A)	1	O-Ring	Joint torique	Junta de tipo O
17	3623178M1	1	1	Gland, Cylinder	Palier de vérin	Palier de gato
18	3402380M1	1 (A)	1	Bushing	Bague	Anillo
19	359193X1	1 (A)	1	O-Ring	Joint torique	Junta de tipo O
20	1606735M1	1 (A)	1	Ring, Backup	Contre-joint	ContraJunta
21	3404681M1	1	1	Wire	Fil	Hilo
22	1606495M1	1 (A)	1	Seal	Joint	Junta
23	834500M1	1 (A)	1	Seal, Wiper	Joint de racleur	Junta raspador
24	3186587M1	1	1	Ring, Snap	Anneau d'arrêt	Anillo de resorte
25	3186586M1	1	1	Ring	Anneau	Aro
26	3441744M91	1	1	Rod, Piston	Tige de vérin	Vástago cilindro
27	MP1056	1	1	Fitting, Grease	Graisneur	Engrasador
28	3484453M94	(B)	1	Kit, Seal	Pochette de joints	Juego de juntas

A Included in kit marked (B)
 Inclus dans jeu marqué (B)
 Incluido en juego marcado (B)

B Contains items marked (A)
 Comprend les pièces marquées (A)
 Incluye las piezas marcadas (A)



820 860 880 970 980
 TX760B TX860B
 TX870B TX970B

801 802 803 804 813 814 815 816 821 822 823 824 831 832 841 842 843 844 851
 852 853 854 922 923 932

70003C03.1

6199042M3

1

Jan-06

Digger Hydraulics
Circuit Hydraulique Défonceuse
Circuito hidráulico equipo retro

Centremount
Montage de Pelle Central
Excavadora de montaje central

Bucket
 Godet
 Cuchara

Std. Spec.
 Std. Spec.
 Std. Spec.

C-76038-01.1-A

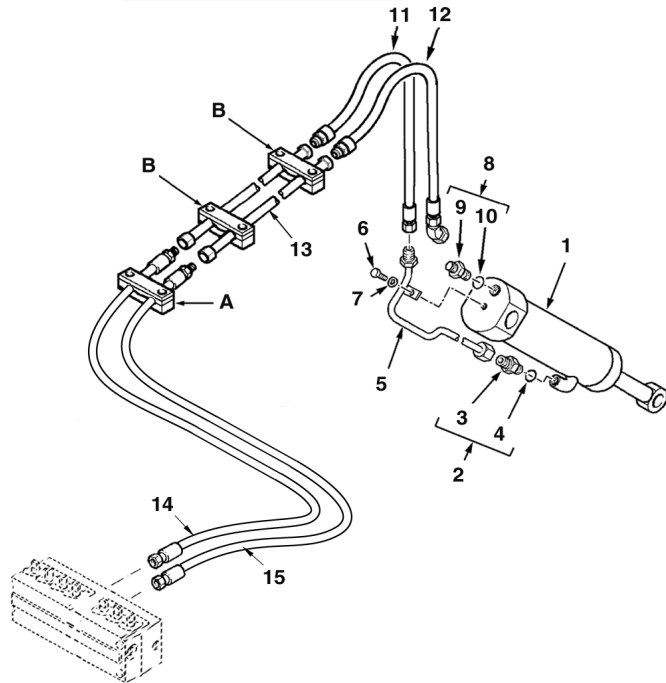
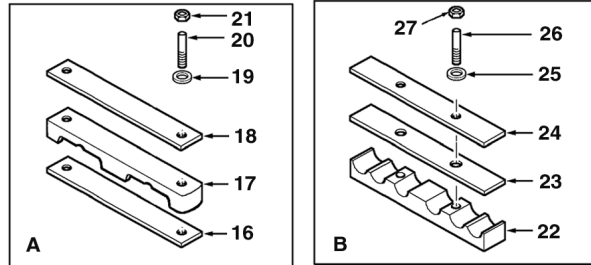

1	5000126M91	76038C02.1 1	1	Cylinder Assy	Ensemble de vérin	Gato, Conj.
2	835013M91		1	Connector Assy	Ensemble connexion	Conexión, Conj.
3		2 Ref. 2	1	Union	Union	Unión
4	835024M1	2	1	O-Ring	Joint torique	Junta de tipo O
5	6101540M91		1	Tube Assy	Tuyauterie	Conjunto de tubería
6	339123X1	M8 x 20	1	Bolt	Boulon	Perno
7	385361X1	M8	1	Washer	Rondelle	Arandela
8	835013M91		1	Connector Assy	Ensemble connexion	Conexión, Conj.
9		8 Ref. 8	1	Union	Union	Unión
10	835024M1	8	1	O-Ring	Joint torique	Junta de tipo O
11	6102309M91	Brown	1	Hose Assy	Ensemble de flexible	Flexible, Conj.
12	6107024M91	White	1	Hose Assy	Ensemble de flexible	Flexible, Conj.
13	6101771M91		2	Tube Assy	Tuyauterie	Conjunto de tubería
14	6102945M91	Brown	1	Hose Assy	Ensemble de flexible	Flexible, Conj.
15	6102942M91	White	1	Hose Assy	Ensemble de flexible	Flexible, Conj.
16	6102128M1		1	Pad	Plaque antidérapante	Cinta antideslizante
17	6102122M1		1	Bracket, Clamp	Bride de fixation	Brida de fijación
18	6102130M1		1	Plate	Plaque	Placa
19	390972X1	M8	2	Washer	Rondelle	Arandela
20	3516075M1	M8 x 65	2	Stud	Goujon	Espárrago
21	394367X1	M8	2	Nut, Lock	Écrou de blocage	Tuerca de retención
22	6102126M1		2	Bracket, Clamp	Bride de fixation	Brida de fijación
23	6102145M1		2	Pad	Plaque antidérapante	Cinta antideslizante
24	6102124M1		2	Plate	Plaque	Placa
25	390972X1	M8	4	Washer	Rondelle	Arandela
26	6108049M1		4	Stud	Goujon	Espárrago
27	394367X1	M8	4	Nut, Lock	Écrou de blocage	Tuerca de retención



820
 TX760B

801 802 803 804 831 832

76038C01.1

6199042M3

1

Jan-06

Digger Hydraulics
Circuit Hydraulique Défonceuse
Circuito hidráulico equipo retro

Centremount
Montage de Pelle Central
Excavadora de montaje central

Bucket Cylinder
Vérin de Godet
Gato de cuchara

Std. Spec.
 Std. Spec.
 Std. Spec.

C-76038-02.1-A

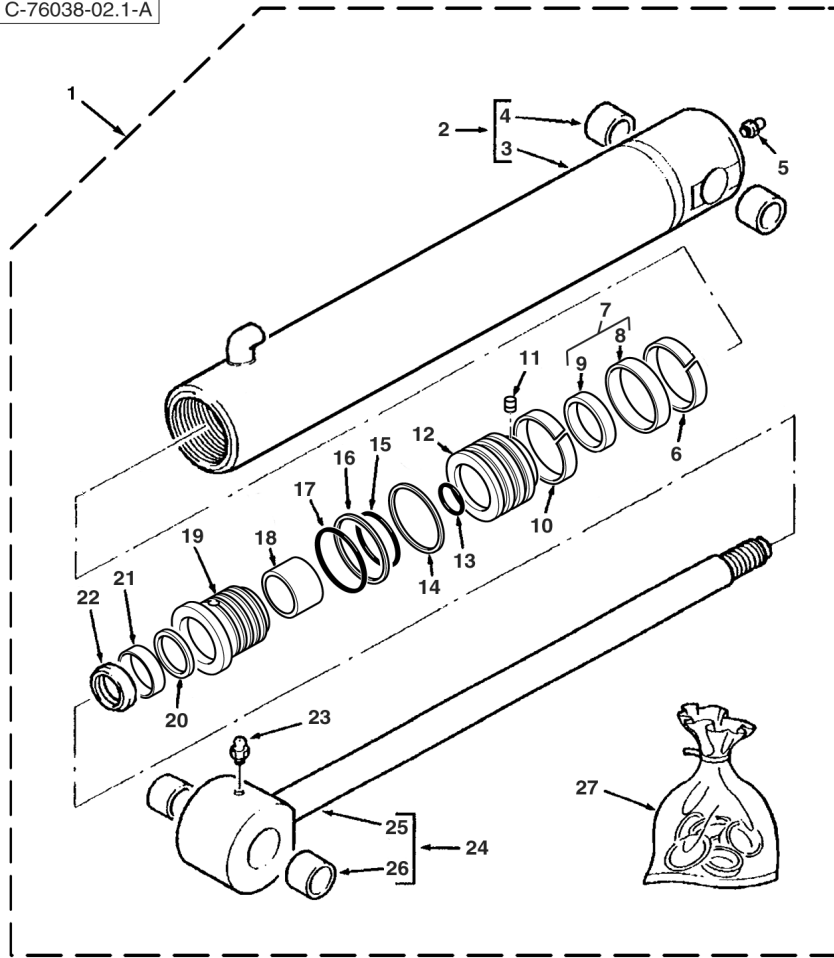

1	5000126M91		76038C01.1 1	1	Cylinder Assy	Ensemble de vérin	Gato, Conj.
2	5004008M91	1		1	Cylinder	Cylindre	Cilindro
3		3	Ref. 2	1	Tube, Cylinder	Cylindre de vérin	Cilindro de gato
4		3 (C)		1	Bushing	Bague	Anillo
5	339608X1	1		1	Fitting, Grease	Graisneur	Engrasador
6	3485892M1	1 (A)		1	Ring, Sealing	Bague d'étanchéité	Anillo, Estanqueidad
7	3485245M91	1 (A)		1	Seal Assy	Ensemble de joint	Junta, Conj.
8		7	Ref. 7	1	Seal	Joint	Junta
9		7	Ref. 7	1	Ring	Anneau	Aro
10	3485892M1	1 (A)		1	Ring, Sealing	Bague d'étanchéité	Anillo, Estanqueidad
11	3402928M1	1		1	Screw	Vis	Tornillo
12	3623372M1	1		1	Piston	Piston	Pistón
13	359186X1	1 (A)		1	O-Ring	Joint torique	Junta de tipo O
14	3623061M1	1		1	Ring, Piston	Segment de piston	Segmento de pistón
15	359193X1	1 (A)		1	O-Ring	Joint torique	Junta de tipo O
16	1606735M1	1 (A)		1	Ring, Backup	Contre-joint	ContraJunta
17	3487207M1	1 (A)		1	O-Ring	Joint torique	Junta de tipo O
18	3484615M1	1 (A)		1	Ring	Anneau	Aro
19	3623371M1	1		1	Bearing	Coussinet	Cojinete
20	3484055M1	1 (A)		1	Ring	Anneau	Aro
21	3485185M1	1 (A)		1	Seal	Joint	Junta
22	3487015M1	1 (A)		1	Ring	Anneau	Aro
23	339608X1	1		1	Fitting, Grease	Graisneur	Engrasador
24	5004012M91	1		1	Rod, Piston	Tige de vérin	Vástago cilindro
25		24	Ref. 24	1	Rod, Piston	Tige de vérin	Vástago cilindro
26		24 (C)		1	Bushing	Bague	Anillo
27	3623373M91		(B)	1	Kit, Seal	Pochette de joints	Juego de juntas

A Contains items marked (A)
 Comprend les pièces marquées (A)
 Incluye las piezas marcadas (A)

C Part number to be advised
 Référence pièce à demander
 Indicar número de pieza

B Included in kit marked (B)
 Inclus dans jeu marqué (B)
 Incluido en juego marcado (B)



820
 TX760B

801 802 803 804 831 832

76038C02.1

6199042M3

1

Jan-06

Digger Hydraulics
Circuit Hydraulique Défonceuse
Circuito hidráulico equipo retro

Centremount
Montage de Pelle Central
Excavadora de montaje central

Standard Dipper
Balancier Standard
Balancín estándar

Std. Spec.
 Std. Spec.
 Std. Spec.

C-76038-03.1-A

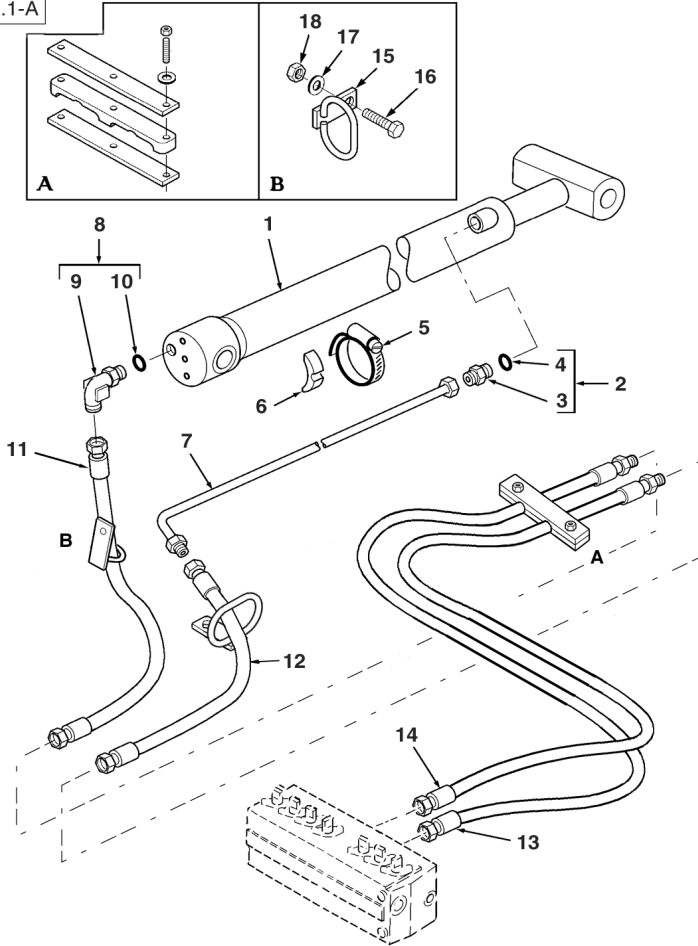

1	5000124M91	76038C04.1 1	1	Cylinder Assy	Ensemble de vérin	Gato, Conj.
2	835013M91		1	Connector Assy	Ensemble connexion	Conexión, Conj.
3		2 Ref. 2	1	Union	Union	Unión
4	835024M1	2	1	O-Ring	Joint torique	Junta de tipo O
5	3517733M1		1	Clamp	Collier de serrage	Argolla de cierre
6	L79937		1	Spacer	Entretoise	Travesa
7	6100976M92	(A)	1	Tube Assy	Tuyauterie	Conjunto de tubería
8	6101624M91	(A)	1	Elbow, 90°	Coude à 90°	Codo, 90°
9		8 (A)	1	Elbow	Coude	Codo
10	835024M1	8 (A)	1	O-Ring	Joint torique	Junta de tipo O
11	6101738M91	Yellow	1	Hose Assy	Ensemble de flexible	Flexible, Conj.
12	6101737M91	Red	1	Hose Assy	Ensemble de flexible	Flexible, Conj.
13	6102941M91	Yellow	1	Hose Assy	Ensemble de flexible	Flexible, Conj.
14	6102944M91	Red	1	Hose Assy	Ensemble de flexible	Flexible, Conj.
15	6101491M92		2	Support Assy	Ensemble de support	Apoyadero, Conj.
16	339761X1	M8 x 25	2	Screw	Vis	Tornillo
17	390972X1	M8	2	Washer	Rondelle	Arandela
18	394367X1	M8	2	Nut, Lock	Écrou de blocage	Tuerca de retención

A Without Hose Burst
 Sans éclatement de tuyau
 Sin rotura de tubo flexible



820
 TX760B

801 802 803 804 831 832

76038C03.1

6199042M3

1

Jan-06

Digger Hydraulics
Circuit Hydraulique Défonceuse
Circuito hidráulico equipo retro

Centremount
Montage de Pelle Central
Excavadora de montaje central

Dipper Cylinder
Vérin de Balancier
Gato de balancín

Std. Spec.
 Std. Spec.
 Std. Spec.

C-76038-04.1-A

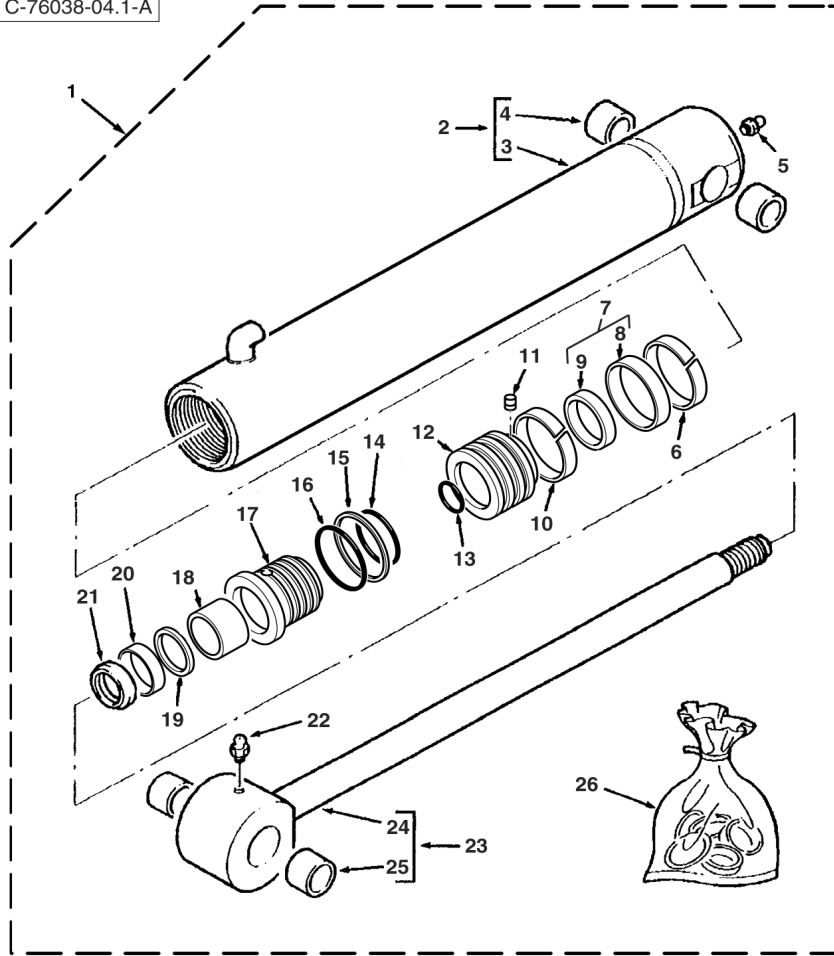

1	5000124M91	76038C03.1 1	1	Cylinder Assy	Ensemble de vérin	Gato, Conj.
2	5003982M91	1	1	Cylinder	Cylindre	Cilindro
3		2	1	Tube, Cylinder	Cylindre de vérin	Cilindro de gato
4	3484843M1	2	1	Bush	Bague	Casquillo
5	339608X1	1	1	Fitting, Grease	Graisneur	Engrasador
6	3485891M1	1 (A)	1	Ring	Anneau	Aro
7	3485247M91	1 (A)	1	Seal Assy	Ensemble de joint	Junta, Conj.
8		7	1	Seal	Joint	Junta
9		7	1	Ring	Anneau	Aro
10	3485891M1	1 (A)	1	Ring	Anneau	Aro
11	3402928M1	1	1	Screw	Vis	Tornillo
12	5003989M1	1	1	Piston	Piston	Pistón
13	3007182X1	1 (A)	1	O-Ring	Joint torique	Junta de tipo O
14	359196X1	1 (A)	1	O-Ring	Joint torique	Junta de tipo O
15	378545X1	1 (A)	1	Ring	Anneau	Aro
16	3487908M1	1 (A)	1	O-Ring	Joint torique	Junta de tipo O
17	5003988M1	1	1	Bearing	Coussinet	Cojinete
18	3623193M1	1 (A)	1	Ring	Anneau	Aro
19	3443388M1	1 (A)	1	Ring	Anneau	Aro
20	3443472M1	1 (A)	1	Seal	Joint	Junta
21	3403385M1	1 (A)	1	Ring, Wiper	Joint de racler	Junta raspador
22	339608X1	1	1	Fitting, Grease	Graisneur	Engrasador
23	5003985M91	1	1	Rod, Piston	Tige de vérin	Vástago cilindro
24		23	1	Rod, Piston	Tige de vérin	Vástago cilindro
25	3484843M1	23	1	Bush	Bague	Casquillo
26	5004401M91	(B)	1	Kit, Seal	Pochette de joints	Juego de juntas

A Included in kit marked (B)
 Inclus dans jeu marqué (B)
 Incluido en juego marcado (B)

B Contains items marked (A)
 Comprend les pièces marquées (A)
 Incluye las piezas marcadas (A)



820
 TX760B

801 802 803 804 831 832

76038C04.1

6199042M3

1

Jan-06

Digger Hydraulics
Circuit Hydraulique Défonceuse
Circuito hidráulico equipo retro

Centremount
Montage de Pelle Central
Excavadora de montaje central

Boom 4.5m
 Flèche 4.5m
 Pluma 4.5m

Std. Spec.
 Std. Spec.
 Std. Spec.

C-76038-05.1-A

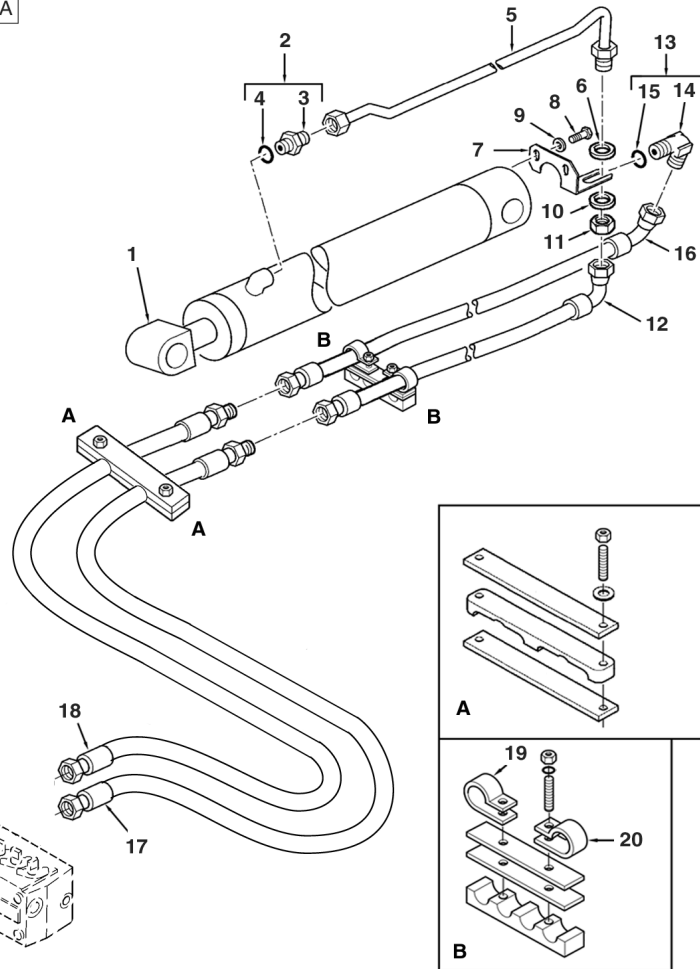

1	5000121M91	76038C06.1 1	1	Cylinder Assy	Ensemble de vérin	Gato, Conj.
2	835013M91		1	Connector Assy	Ensemble connexion	Conexión, Conj.
3		Ref. 2	1	Union	Union	Unión
4	835024M1	2	1	O-Ring	Joint torique	Junta de tipo O
5	6100855M91	(A)	1	Tube Assy	Tuyauterie	Conjunto de tubería
6	353763X1	(A)	1	Washer	Rondelle	Arandela
7	6100883M1	(A)	1	Bracket	Patte de fixation	Pata de fijación
8	339228X1	M8 x 12	2	Screw	Vis	Tornillo
9	339374X1	M8	2	Washer, Lock	Rondelle de blocage	Arandela de freno
10	353763X1	(A)	1	Washer	Rondelle	Arandela
11	355574X1	(A)	1	Nut	Écrou	Tuerca
12	6101735M92	(A) Orange	1	Hose Assy	Ensemble de flexible	Flexible, Conj.
13	835007M91	(A)	1	Elbow, 90°	Coude à 90°	Codo, 90°
14		Ref. 13	1	Elbow	Coude	Codo
15	835024M1	13	1	O-Ring	Joint torique	Junta de tipo O
16	6101736M92	Blue	1	Hose Assy	Ensemble de flexible	Flexible, Conj.
17	6102943M91	Orange	1	Hose Assy	Ensemble de flexible	Flexible, Conj.
18	6102940M91	Blue	1	Hose Assy	Ensemble de flexible	Flexible, Conj.
19	515-23270		1	Clip	Clip	Clip
20	515-23206		1	Clip	Clip	Clip

A Without Hose Burst
 Sans éclatement de tuyau
 Sin rotura de tubo flexible



801 802 803 804 831 832

76038C05.1

6199042M3

1

Jan-06

Digger Hydraulics
Circuit Hydraulique Défonceuse
Circuito hidráulico equipo retro

Centremount
Montage de Pelle Central
Excavadora de montaje central

Boom Cylinder
Vérin de Flèche
Gato de pluma

Std. Spec.
 Std. Spec.
 Std. Spec.

C-76038-06.1-A

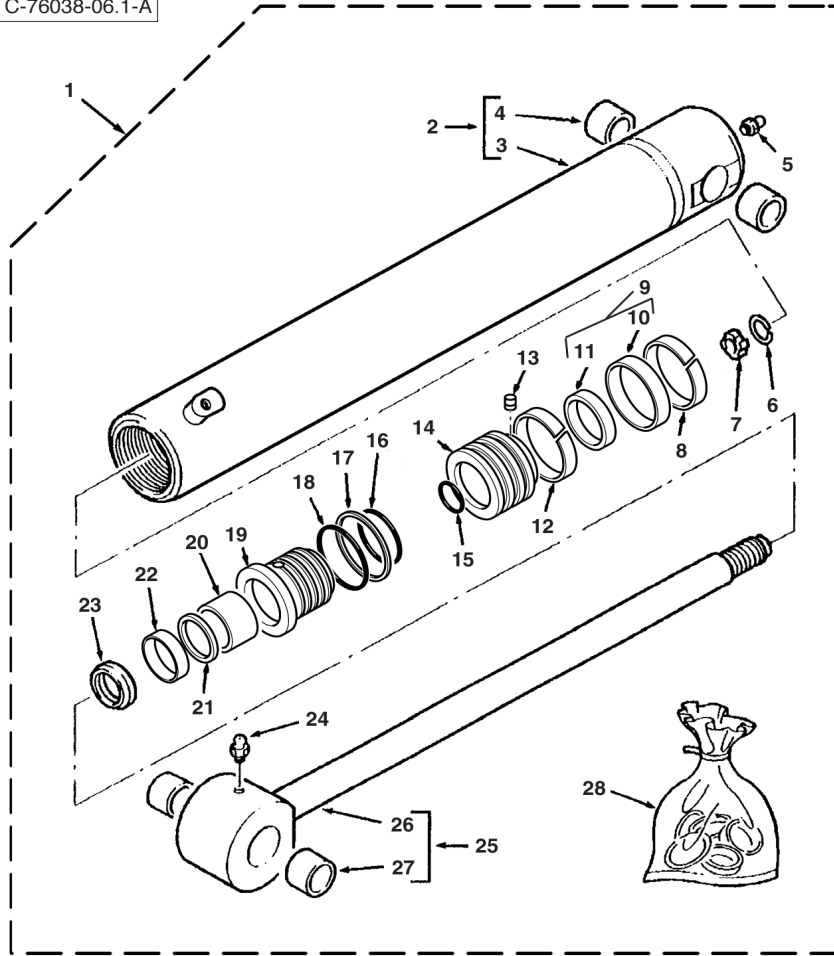

1	5000121M91	76030C05.1 1	1	Cylinder Assy	Ensemble de vérin	Gato, Conj.
2	5003974M91	1	1	Cylinder	Cylindre	Cilindro
3		2	1	Tube, Cylinder	Cylindre de vérin	Cilindro de gato
4		2 (C)	2	Bushing	Bague	Anillo
5	339608X1	1	1	Fitting, Grease	Graisseur	Engrasador
6	1609899M1	1	1	Ring, Snap	Anneau d'arrêt	Anillo de resorte
7	1609328M1	1	1	Ring	Anneau	Aro
8	3442376M1	1 (A)	1	Ring	Anneau	Aro
9	3485249M91	1 (A)	1	Seal	Joint	Junta
10		9	1	Seal	Joint	Junta
11		9	1	Seal	Joint	Junta
12	3442376M1	1	1	Ring	Anneau	Aro
13	3402928M1	1	1	Screw	Vis	Tornillo
14	5003980M1	1	1	Piston	Piston	Pistón
15	3007182X1	1 (A)	1	O-Ring	Joint torique	Junta de tipo O
16	359201X1	1 (A)	1	O-Ring	Joint torique	Junta de tipo O
17	1024334M1	1 (A)	1	Ring	Anneau	Aro
18	3487909M1	1 (A)	1	O-Ring	Joint torique	Junta de tipo O
19	5003979M1	1	1	Bearing	Coussinet	Cojinete
20	3623193M1	1 (A)	1	Ring	Anneau	Aro
21	3443388M1	1 (A)	1	Ring	Anneau	Aro
22	3443472M1	1 (A)	1	Seal	Joint	Junta
23	3403385M1	1 (A)	1	Ring, Wiper	Joint de racleur	Junta raspador
24	339608X1	1	1	Fitting, Grease	Graisseur	Engrasador
25	3441629M91	1	1	Rod, Piston	Tige de vérin	Vástago cilindro
26		25	1	Rod, Piston	Tige de vérin	Vástago cilindro
27	3484843M1	25	1	Bush	Bague	Casquillo
28	5004400M91	(B)	1	Kit, Seal	Pochette de joints	Juego de juntas

A Included in kit marked (B)
 Inclus dans jeu marqué (B)
 Incluido en juego marcado (B)
 Part number to be advised
 Référence pièce à demander
 Indicar número de pieza

B Contains items marked (A)
 Comprend les pièces marquées (A)
 Incluye las piezas marcadas (A)



820
 TX760B

801 802 803 804 831 832

76038C06.1

6199042M3

1

Jan-06

Digger Hydraulics
Circuit Hydraulique Défonceuse
Circuito hidráulico equipo retro

Centremount
Montage de Pelle Central
Excavadora de montaje central

Swing Components
Organes de Rotation
Componentes de rotación

Std. Spec.
 Std. Spec.
 Std. Spec.

C-76038-07.1-A

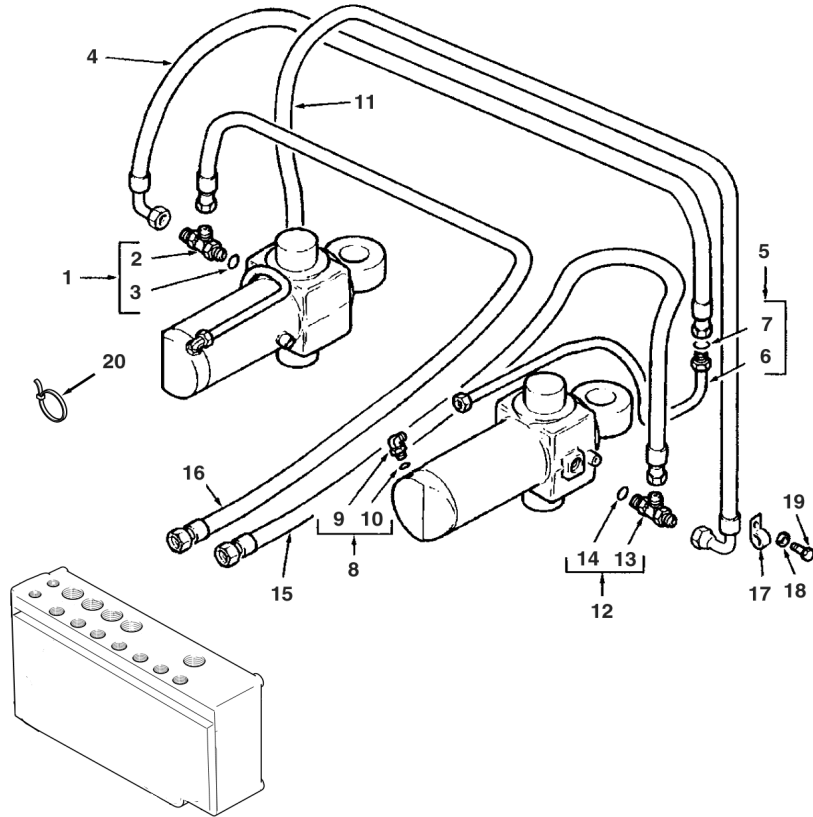

1	358728X91			1	Tee	Raccord en T	Te
2		1	▶ Ref. 1	1	Tee	Raccord en T	Te
3	831497M1	1		1	O-Ring	Joint torique	Junta de tipo O
4	6100716M91	840 mm		1	Hose Assy	Ensemble de flexible	Flexible, Conj.
5	6100587M91		◀	1	Tube Assy	Tuyauterie	Conjunto de tubería
5	6100589M91		▶	1	Tube Assy	Tuyauterie	Conjunto de tubería
6		5	▶ Ref. 5	1	Tube	Tube	Tubo
7	394923X1	5		1	O-Ring	Joint torique	Junta de tipo O
8	357197X91			2	Elbow, 90°	Coude à 90°	Codo, 90°
9		8	▶ Ref. 8	1	Elbow	Coude	Codo
10	831452M1	8		1	O-Ring	Joint torique	Junta de tipo O
11	6100716M91	840 mm		1	Hose Assy	Ensemble de flexible	Flexible, Conj.
12	358728X91			1	Tee	Raccord en T	Te
13		12	▶ Ref. 12	1	Tee	Raccord en T	Te
14	831497M1	12		1	O-Ring	Joint torique	Junta de tipo O
15	6100715M92	Purple 700mm		1	Hose Assy	Ensemble de flexible	Flexible, Conj.
16	6101866M93	Green 700mm		1	Hose Assy	Ensemble de flexible	Flexible, Conj.
17	3517114M2			2	Clip, Mounting	Collier de fixation	Argolla de fijación
18	385361X1	M8		2	Washer	Rondelle	Arandela
19	339228X1	M8 x 12		2	Screw	Vis	Tornillo
20	1862425M1			1	Tie, Cable	Attache câble	Enlace de Cable



820
TX760B

801 802 803 804 831 832

76038C07.1

6199042M3

1

Jan-06

Digger Hydraulics
Circuit Hydraulique Défonceuse
Circuito hidráulico equipo retro

Centremount
Montage de Pelle Central
Excavadora de montaje central

Bucket
 Godet
 Cuchara

Std. Spec.
 Std. Spec.
 Std. Spec.

C-76039-01.1-A

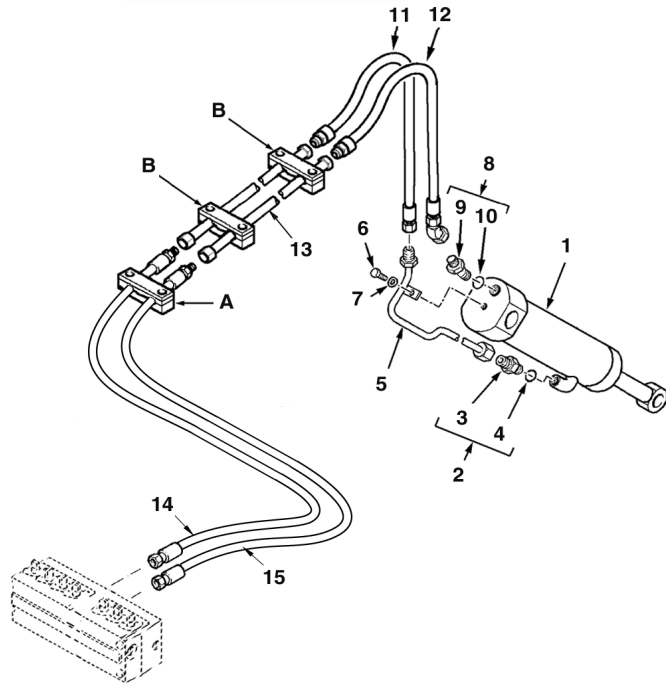
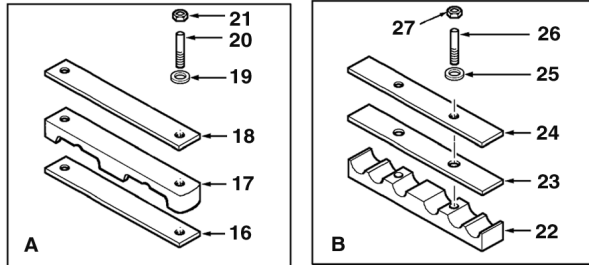

1	5000126M91	76039C02.1 1	1	Cylinder Assy	Ensemble de vérin	Gato, Conj.
2	835013M91		1	Connector Assy	Ensemble connexion	Conexión, Conj.
3		2 Ref. 2	1	Union	Union	Unión
4	835024M1	2	1	O-Ring	Joint torique	Junta de tipo O
5	6101540M91		1	Tube Assy	Tuyauterie	Conjunto de tubería
6	339123X1	M8 x 20	1	Bolt	Boulon	Perno
7	385361X1	M8	1	Washer	Rondelle	Arandela
8	835010M91		1	Elbow, 45°	Coude à 45°	Codo, 45°
9		8 Ref. 8	1	Elbow	Coude	Codo
10	835024M1	8	1	O-Ring	Joint torique	Junta de tipo O
11		(A)Brown	1	Hose Assy	Ensemble de flexible	Flexible, Conj.
12		(A)White	1	Hose Assy	Ensemble de flexible	Flexible, Conj.
13	6101771M91		2	Tube Assy	Tuyauterie	Conjunto de tubería
14	6102945M91	Brown	1	Hose Assy	Ensemble de flexible	Flexible, Conj.
15	6102942M91	White	1	Hose Assy	Ensemble de flexible	Flexible, Conj.
16	6102128M1		1	Pad	Plaque antidérapante	Cinta antideslizante
17	6102122M1		1	Bracket, Clamp	Bride de fixation	Brida de fijación
18	6102130M1		1	Plate	Plaque	Placa
19	390972X1	M8	2	Washer	Rondelle	Arandela
20	3516075M1	M8 x 65	2	Stud	Goujon	Espárrago
21	394367X1	M8	2	Nut, Lock	Écrou de blocage	Tuerca de retención
22	6102126M1		2	Bracket, Clamp	Bride de fixation	Brida de fijación
23	6102145M1		2	Pad	Plaque antidérapante	Cinta antideslizante
24	6102124M1		2	Plate	Plaque	Placa
25	390972X1	M8	4	Washer	Rondelle	Arandela
26	6108049M1		4	Stud	Goujon	Espárrago
27	394367X1	M8	4	Nut, Lock	Écrou de blocage	Tuerca de retención

A See extendahoe hydraulics section
 Voir la section circuit hydraulique extendahoe
 Ver la sección de la circuito hidráulico extendahoe



820
 TX760B

801 802 803 804 831 832

76039C01.1

6199042M3

1

Jan-06

Digger Hydraulics
Circuit Hydraulique Défonceuse
Circuito hidráulico equipo retro

Centremount
Montage de Pelle Central
Excavadora de montaje central

Bucket Cylinder
Vérin de Godet
Gato de cuchara

Std. Spec.
 Std. Spec.
 Std. Spec.

C-76039-02.1-A

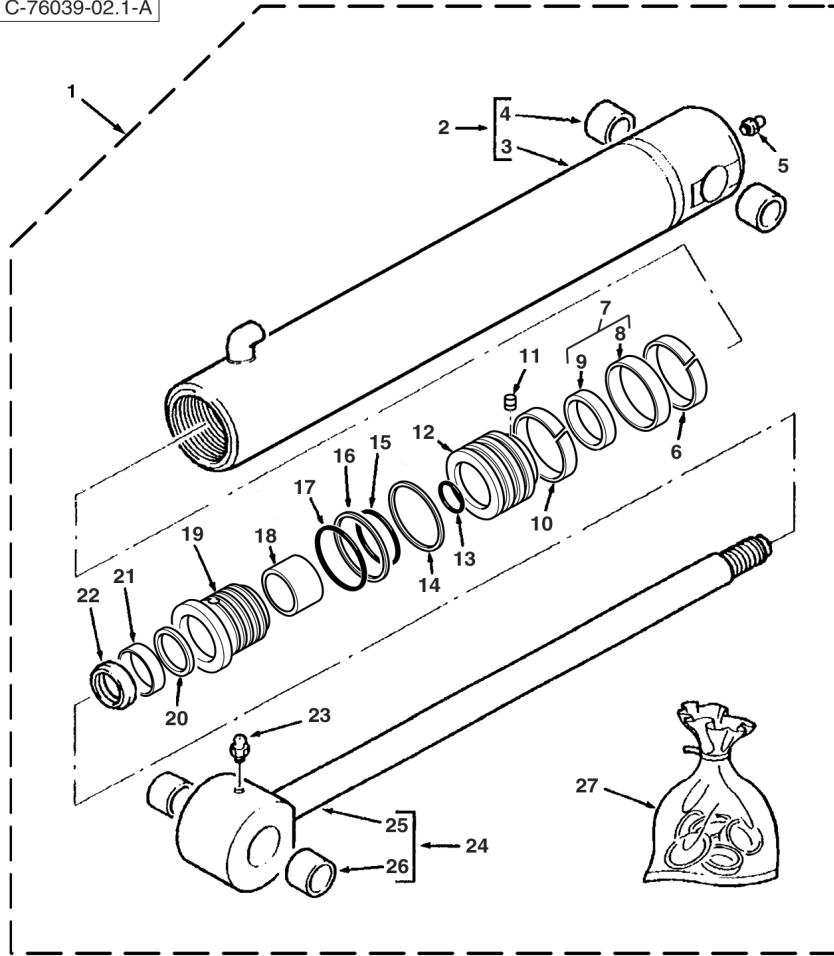

1	5000126M91		76039C01.1 1	1	Cylinder Assy	Ensemble de vérin	Gato, Conj.
2	5004008M91	1		1	Cylinder	Cylindre	Cilindro
3		3	Ref. 2	1	Tube, Cylinder	Cylindre de vérin	Cilindro de gato
4		3 (C)		1	Bushing	Bague	Anillo
5	339608X1	1		1	Fitting, Grease	Graisneur	Engrasador
6	3485892M1	1 (A)		1	Ring, Sealing	Bague d'étanchéité	Anillo, Estanqueidad
7	3485245M91	1 (A)		1	Seal Assy	Ensemble de joint	Junta, Conj.
8		7	Ref. 7	1	Seal	Joint	Junta
9		7	Ref. 7	1	Ring	Anneau	Aro
10	3485892M1	1 (A)		1	Ring, Sealing	Bague d'étanchéité	Anillo, Estanqueidad
11	3402928M1	1		1	Screw	Vis	Tornillo
12	3623372M1	1		1	Piston	Piston	Pistón
13	359186X1	1 (A)		1	O-Ring	Joint torique	Junta de tipo O
14	3623061M1	1		1	Ring, Piston	Segment de piston	Segmento de pistón
15	359193X1	1 (A)		1	O-Ring	Joint torique	Junta de tipo O
16	1606735M1	1 (A)		1	Ring, Backup	Contre-joint	ContraJunta
17	3487207M1	1 (A)		1	O-Ring	Joint torique	Junta de tipo O
18	3484615M1	1 (A)		1	Ring	Anneau	Aro
19	3623371M1	1		1	Bearing	Coussinet	Cojinete
20	3484055M1	1 (A)		1	Ring	Anneau	Aro
21	3485185M1	1 (A)		1	Seal	Joint	Junta
22	3487015M1	1 (A)		1	Ring	Anneau	Aro
23	339608X1	1		1	Fitting, Grease	Graisneur	Engrasador
24	5004012M91	1		1	Rod, Piston	Tige de vérin	Vástago cilindro
25		24	Ref. 24	1	Rod, Piston	Tige de vérin	Vástago cilindro
26		24 (C)		1	Bushing	Bague	Anillo
27	3623373M91		(B)	1	Kit, Seal	Pochette de joints	Juego de juntas

A Contains items marked (A)
 Comprend les pièces marquées (A)
 Incluye las piezas marcadas (A)
 C Part number to be advised
 Référence pièce à demander
 Indicar número de pieza

B Included in kit marked (B)
 Inclus dans jeu marqué (B)
 Incluido en juego marcado (B)



820
 TX760B

801 802 803 804 831 832

76039C02.1

6199042M3

1

Jan-06

Digger Hydraulics
Circuit Hydraulique Défonceuse
Circuito hidráulico equipo retro

Centremount
Montage de Pelle Central
Excavadora de montaje central

Telescopic Dipper
Balancier Téléscopique
Balancín telescópico

Std. Spec.
 Std. Spec.
 Std. Spec.

C-76039-03.1-A

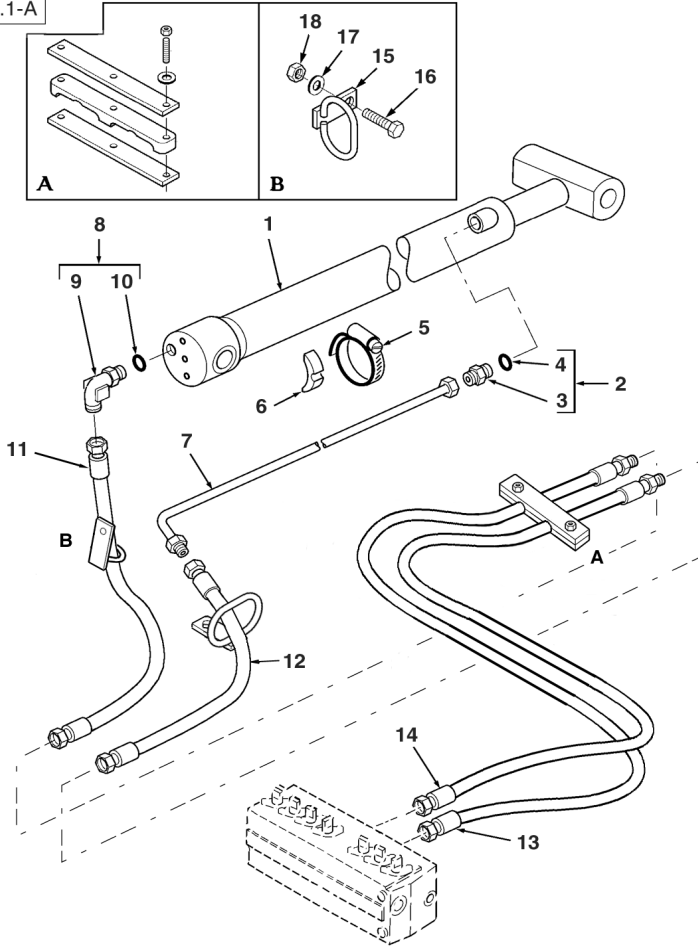

1	5000124M91	76039C04.1 1	1	Cylinder Assy	Ensemble de vérin	Gato, Conj.
2	835013M91		1	Connector Assy	Ensemble connexion	Conexión, Conj.
3		2 Ref. 2	1	Union	Union	Unión
4	835024M1	2	1	O-Ring	Joint torique	Junta de tipo O
5	3517733M1		1	Clamp	Collier de serrage	Argolla de cierre
6	L79937		1	Spacer	Entretoise	Travesa
7	6100976M92	(A)	1	Tube Assy	Tuyauterie	Conjunto de tubería
8	6101624M91	(A)	1	Elbow, 90°	Coude à 90°	Codo, 90°
9		8 (A) Ref. 8	1	Elbow	Coude	Codo
10	835024M1	8 (A)	1	O-Ring	Joint torique	Junta de tipo O
11	6101738M91	Yellow	1	Hose Assy	Ensemble de flexible	Flexible, Conj.
12	6101737M91	Red	1	Hose Assy	Ensemble de flexible	Flexible, Conj.
13	6102941M91	Yellow	1	Hose Assy	Ensemble de flexible	Flexible, Conj.
14	6102944M91	Red	1	Hose Assy	Ensemble de flexible	Flexible, Conj.
15	6101491M92		2	Support Assy	Ensemble de support	Apoyadero, Conj.
16	339761X1	M8 x 25	2	Screw	Vis	Tornillo
17	390972X1	M8	2	Washer	Rondelle	Arandela
18	394367X1	M8	2	Nut, Lock	Écrou de blocage	Tuerca de retención

A Without Hose Burst
 Sans éclatement de tuyau
 Sin rotura de tubo flexible



820
 TX760B

801 802 803 804 831 832

76039C03.1

6199042M3

1

Jan-06

Digger Hydraulics
Circuit Hydraulique Défonceuse
Circuito hidráulico equipo retro

Centremount
Montage de Pelle Central
Excavadora de montaje central

Dipper Cylinder
Vérin de Balancier
Gato de balancín

Std. Spec.
 Std. Spec.
 Std. Spec.

C-76039-04.1-A

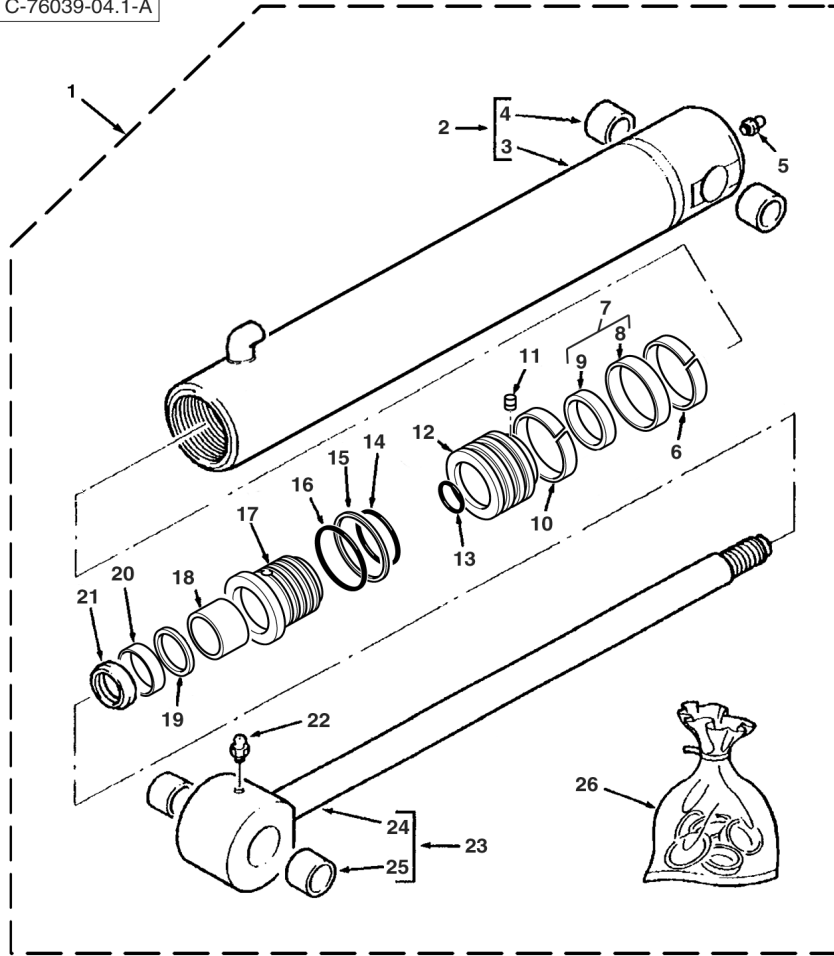

1	5000124M91		76039C03.1 1	1	Cylinder Assy	Ensemble de vérin	Gato, Conj.
2	5003982M91	1		1	Cylinder	Cylindre	Cilindro
3		2	Ref. 2	1	Tube, Cylinder	Cylindre de vérin	Cilindro de gato
4	3484843M1	2		1	Bush	Bague	Casquillo
5	339608X1	1		1	Fitting, Grease	Graisneur	Engrasador
6	3485891M1	1 (A)		1	Ring	Anneau	Aro
7	3485247M91	1 (A)		1	Seal Assy	Ensemble de joint	Junta, Conj.
8		7	Ref. 7	1	Seal	Joint	Junta
9		7	Ref. 7	1	Ring	Anneau	Aro
10	3485891M1	1 (A)		1	Ring	Anneau	Aro
11	3402928M1	1		1	Screw	Vis	Tornillo
12	5003989M1	1		1	Piston	Piston	Pistón
13	3007182X1	1 (A)		1	O-Ring	Joint torique	Junta de tipo O
14	359196X1	1 (A)		1	O-Ring	Joint torique	Junta de tipo O
15	378545X1	1 (A)		1	Ring	Anneau	Aro
16	3487908M1	1 (A)		1	O-Ring	Joint torique	Junta de tipo O
17	5003988M1	1		1	Bearing	Coussinet	Cojinete
18	3623193M1	1 (A)		1	Ring	Anneau	Aro
19	3443388M1	1 (A)		1	Ring	Anneau	Aro
20	3443472M1	1 (A)		1	Seal	Joint	Junta
21	3403385M1	1 (A)		1	Ring, Wiper	Joint de racler	Junta raspador
22	339608X1	1		1	Fitting, Grease	Graisneur	Engrasador
23	5003985M91	1		1	Rod, Piston	Tige de vérin	Vástago cilindro
24		23	Ref. 23	1	Rod, Piston	Tige de vérin	Vástago cilindro
25	3484843M1	23		1	Bush	Bague	Casquillo
26	5004401M91		(B)	1	Kit, Seal	Pochette de joints	Juego de juntas

A Included in kit marked (B)
 Inclus dans jeu marqué (B)
 Incluido en juego marcado (B)

B Contains items marked (A)
 Comprend les pièces marquées (A)
 Incluye las piezas marcadas (A)



820
 TX760B

801 802 803 804 831 832

76039C04.1

6199042M3

1

Jan-06

Digger Hydraulics
Circuit Hydraulique Défonceuse
Circuito hidráulico equipo retro

Centremount
Montage de Pelle Central
Excavadora de montaje central

Boom 4.5m
 Flèche 4.5m
 Pluma 4.5m

Std. Spec.
 Std. Spec.
 Std. Spec.

C-76039-05.1-A

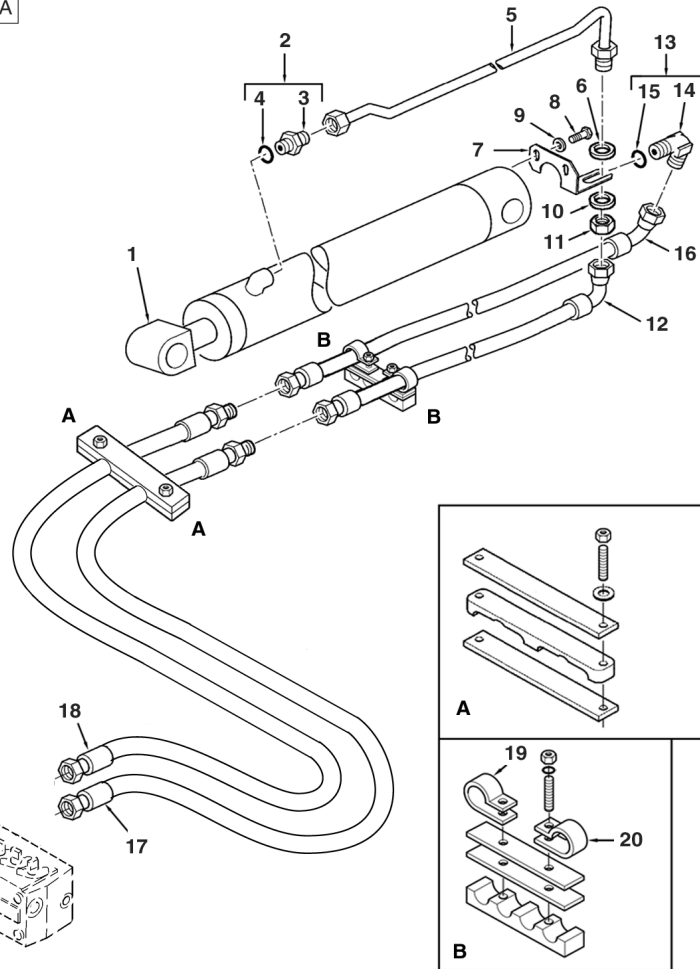

1	5000121M91	76039C06.1 1	1	Cylinder Assy	Ensemble de vérin	Gato, Conj.
2	835013M91		1	Connector Assy	Ensemble connexion	Conexión, Conj.
3		Ref. 2	1	Union	Union	Unión
4	835024M1	2	1	O-Ring	Joint torique	Junta de tipo O
5	6100855M91	(A)	1	Tube Assy	Tuyauterie	Conjunto de tubería
6	353763X1	(A)	1	Washer	Rondelle	Arandela
7	6100883M1	(A)	1	Bracket	Patte de fixation	Pata de fijación
8	339228X1	M8 x 12	2	Screw	Vis	Tornillo
9	339374X1	M8	2	Washer, Lock	Rondelle de blocage	Arandela de freno
10	353763X1	(A)	1	Washer	Rondelle	Arandela
11	355574X1	(A)	1	Nut	Écrou	Tuerca
12	6101735M92	(A) Orange	1	Hose Assy	Ensemble de flexible	Flexible, Conj.
13	835007M91	(A)	1	Elbow, 90°	Coude à 90°	Codo, 90°
14		Ref. 13	1	Elbow	Coude	Codo
15	835024M1	13	1	O-Ring	Joint torique	Junta de tipo O
16	6101736M92	Blue	1	Hose Assy	Ensemble de flexible	Flexible, Conj.
17	6102943M91	Orange	1	Hose Assy	Ensemble de flexible	Flexible, Conj.
18	6102940M91	Blue	1	Hose Assy	Ensemble de flexible	Flexible, Conj.
19	515-23270		1	Clip	Clip	Clip
20	515-23206		1	Clip	Clip	Clip

A Without Hose Burst
 Sans éclatement de tuyau
 Sin rotura de tubo flexible



820
 TX760B

801 802 803 804 831 832

76039C05.1

6199042M3

1

Jan-06

Digger Hydraulics
Circuit Hydraulique Défonceuse
Circuito hidráulico equipo retro

Centremount
Montage de Pelle Central
Excavadora de montaje central

Boom Cylinder
Vérin de Flèche
Gato de pluma

Std. Spec.
 Std. Spec.
 Std. Spec.

C-76039-06.1-A

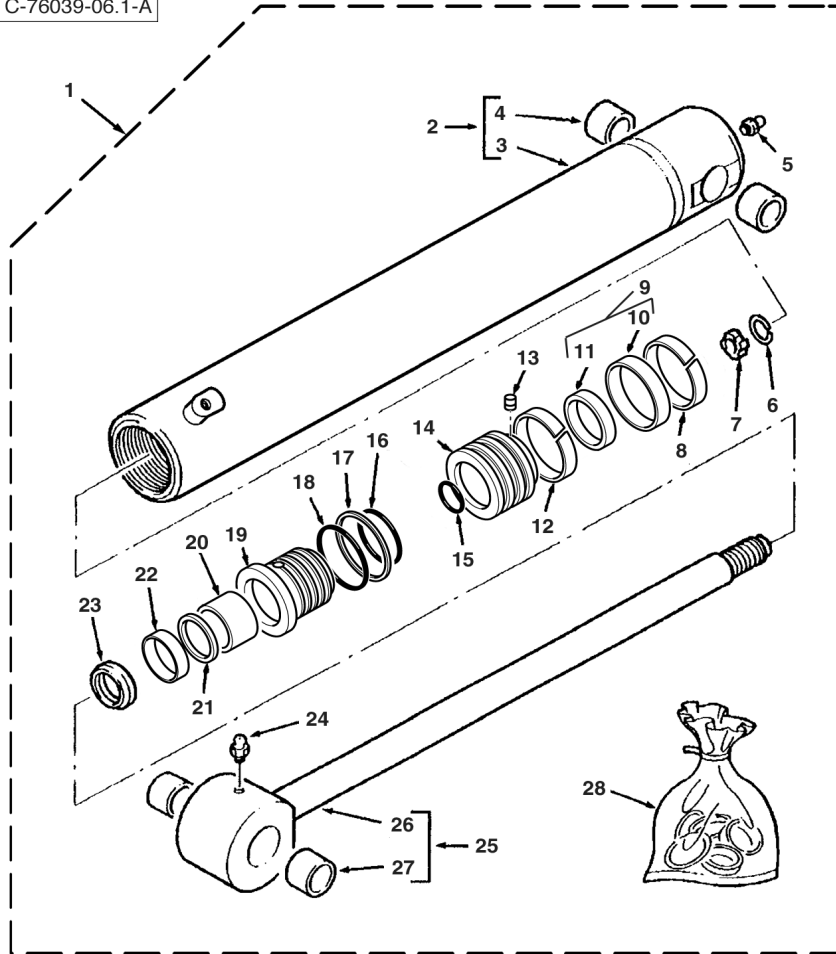

1	5000121M91		76039C05.1 1	1	Cylinder Assy	Ensemble de vérin	Gato, Conj.
2	5003974M91	1		1	Cylinder	Cylindre	Cilindro
3		2	Ref. 2	1	Tube, Cylinder	Cylindre de vérin	Cilindro de gato
4		2 (C)		2	Bushing	Bague	Anillo
5	339608X1	1		1	Fitting, Grease	Graisseur	Engrasador
6	1609899M1	1		1	Ring, Snap	Anneau d'arrêt	Anillo de resorte
7	1609328M1	1		1	Ring	Anneau	Aro
8	3442376M1	1 (A)		2	Ring	Anneau	Aro
9	3485249M91	1 (A)		1	Seal	Joint	Junta
10		9	Ref. 9	1	Seal	Joint	Junta
11		9	Ref. 9	1	Seal	Joint	Junta
12	3442376M1	1		1	Ring	Anneau	Aro
13	3402928M1	1		1	Screw	Vis	Tornillo
14	5003980M1	1		1	Piston	Piston	Pistón
15	3007182X1	1 (A)		1	O-Ring	Joint torique	Junta de tipo O
16	359201X1	1 (A)		1	O-Ring	Joint torique	Junta de tipo O
17	1024334M1	1 (A)		1	Ring	Anneau	Aro
18	3487909M1	1 (A)		1	O-Ring	Joint torique	Junta de tipo O
19	5003979M1	1		1	Bearing	Coussinet	Cojinete
20	3623193M1	1 (A)		1	Ring	Anneau	Aro
21	3443388M1	1 (A)		1	Ring	Anneau	Aro
22	3443472M1	1 (A)		1	Seal	Joint	Junta
23	3403385M1	1 (A)		1	Ring, Wiper	Joint de racleur	Junta raspador
24	339608X1	1		1	Fitting, Grease	Graisseur	Engrasador
25	3441629M91	1		1	Rod, Piston	Tige de vérin	Vástago cilindro
26		25	Ref. 25	1	Rod, Piston	Tige de vérin	Vástago cilindro
27	3484843M1	25		1	Bush	Bague	Casquillo
28	5004400M91	(B)		1	Kit, Seal	Pochette de joints	Juego de juntas

A Included in kit marked (B)
 Inclus dans jeu marqué (B)
 Incluido en juego marcado (B)
 Part number to be advised
 Référence pièce à demander
 Indicar número de pieza

B Contains items marked (A)
 Comprend les pièces marquées (A)
 Incluye las piezas marcadas (A)



820
 TX760B

801 802 803 804 831 832

76039C06.1

6199042M3

1

Jan-06

Digger Hydraulics
Circuit Hydraulique Défonceuse
Circuito hidráulico equipo retro

Centremount
Montage de Pelle Central
Excavadora de montaje central

Swing Components
Organes de Rotation
Componentes de rotación

Std. Spec.
 Std. Spec.
 Std. Spec.

C-76039-07.1-A

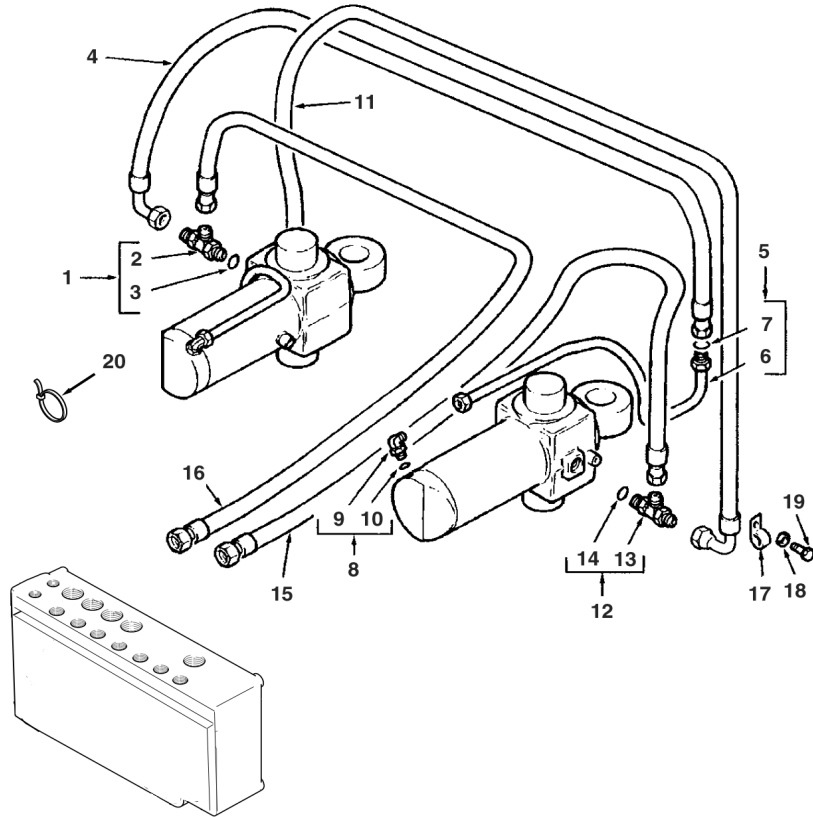

1	358728X91		1	Tee	Raccord en T	Te
2		1	▶ Ref. 1	1	Tee	Raccord en T
3	831497M1	1		1	O-Ring	Joint torique
4	6100716M91	840 mm		1	Hose Assy	Ensemble de flexible
5	6100587M91	▶		1	Tube Assy	Tuyauterie
5	6100589M91	▶		1	Tube Assy	Tuyauterie
6		5	▶ Ref. 5	1	Tube	Tube
7	394923X1	5		1	O-Ring	Joint torique
8	357197X91			2	Elbow, 90°	Coude à 90°
9		8	▶ Ref. 8	1	Elbow	Coude
10	831452M1	8		1	O-Ring	Joint torique
11	6100716M91	840 mm		1	Hose Assy	Ensemble de flexible
12	358728X91			1	Tee	Raccord en T
13		12	▶ Ref. 12	1	Tee	Raccord en T
14	831497M1	12		1	O-Ring	Joint torique
15	6100715M92	Purple 700mm		1	Hose Assy	Ensemble de flexible
16	6101866M93	Green 700mm		1	Hose Assy	Ensemble de flexible
17	3517114M2			2	Clip, Mounting	Collier de fixation
18	385361X1	M8		2	Washer	Rondelle
19	339228X1	M8 x 12		2	Screw	Vis
20	1862425M1			1	Tie, Cable	Attache câble



820
TX760B

801 802 803 804 831 832

76039C07.1

6199042M3

1

Jan-06

Digger Hydraulics
Circuit Hydraulique Défonceuse
Circuito hidráulico equipo retro

Centremount
Montage de Pelle Central
Excavadora de montaje central

Bucket
 Godet
 Cuchara

High Spec.
 High Spec.
 High Spec.

C-76040-01.1-A

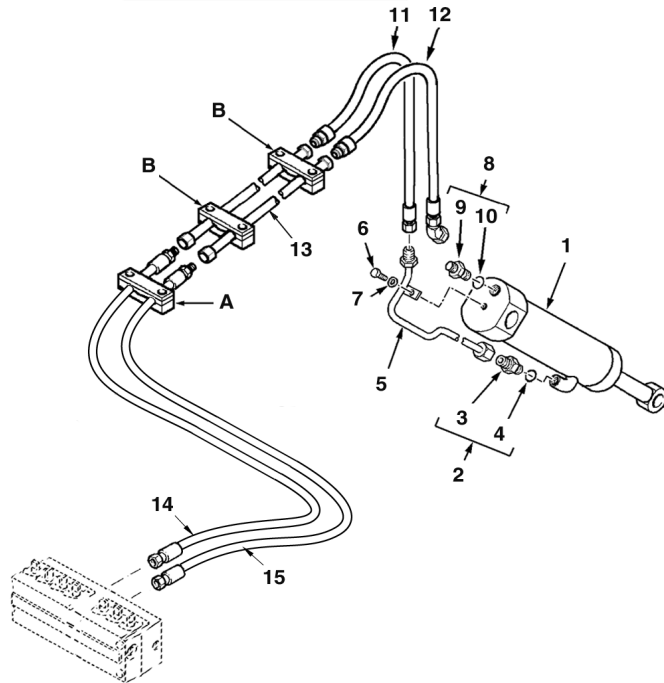
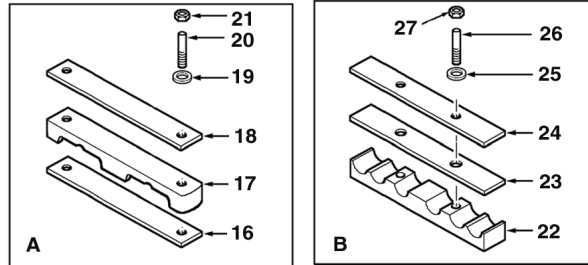

1	5000126M91	76040C02.1 1	1	Cylinder Assy	Ensemble de vérin	Gato, Conj.
2	835013M91		1	Connector Assy	Ensemble connexion	Conexión, Conj.
3		2 Ref. 2	1	Union	Union	Unión
4	835024M1	2	1	O-Ring	Joint torique	Junta de tipo O
5	6101540M91		1	Tube Assy	Tuyauterie	Conjunto de tubería
6	339123X1	M8 x 20	1	Bolt	Boulon	Perno
7	385361X1	M8	1	Washer	Rondelle	Arandela
8	835013M91		1	Connector Assy	Ensemble connexion	Conexión, Conj.
9		8 Ref. 8	1	Union	Union	Unión
10	835024M1	8	1	O-Ring	Joint torique	Junta de tipo O
11	6102309M91	Brown	1	Hose Assy	Ensemble de flexible	Flexible, Conj.
12	6107024M91	White	1	Hose Assy	Ensemble de flexible	Flexible, Conj.
13	6101771M91		2	Tube Assy	Tuyauterie	Conjunto de tubería
14	6102945M91	Brown	1	Hose Assy	Ensemble de flexible	Flexible, Conj.
15	6102942M91	White	1	Hose Assy	Ensemble de flexible	Flexible, Conj.
16	6102128M1		1	Pad	Plaque antidérapante	Cinta antideslizante
17	6102122M1		1	Bracket, Clamp	Bride de fixation	Brida de fijación
18	6102130M1		1	Plate	Plaque	Placa
19	390972X1	M8	2	Washer	Rondelle	Arandela
20	3516075M1	M8 x 65	2	Stud	Goujon	Espárrago
21	394367X1	M8	2	Nut, Lock	Écrou de blocage	Tuerca de retención
22	6102126M1		2	Bracket, Clamp	Bride de fixation	Brida de fijación
23	6102145M1		2	Pad	Plaque antidérapante	Cinta antideslizante
24	6102124M1		2	Plate	Plaque	Placa
25	390972X1	M8	4	Washer	Rondelle	Arandela
26	6108049M1		4	Stud	Goujon	Espárrago
27	394367X1	M8	4	Nut, Lock	Écrou de blocage	Tuerca de retención



860 880 970
 TX860B

809 810 813 814 821 822 841 842 851 852 922

76040C01.1

6199042M3

1

Jan-06

Digger Hydraulics
Circuit Hydraulique Défonceuse
Circuito hidráulico equipo retro

Centremount
Montage de Pelle Central
Excavadora de montaje central

Bucket Cylinder
Vérin de Godet
Gato de cuchara

High Spec.
 High Spec.
 High Spec.

C-76040-02.1-A

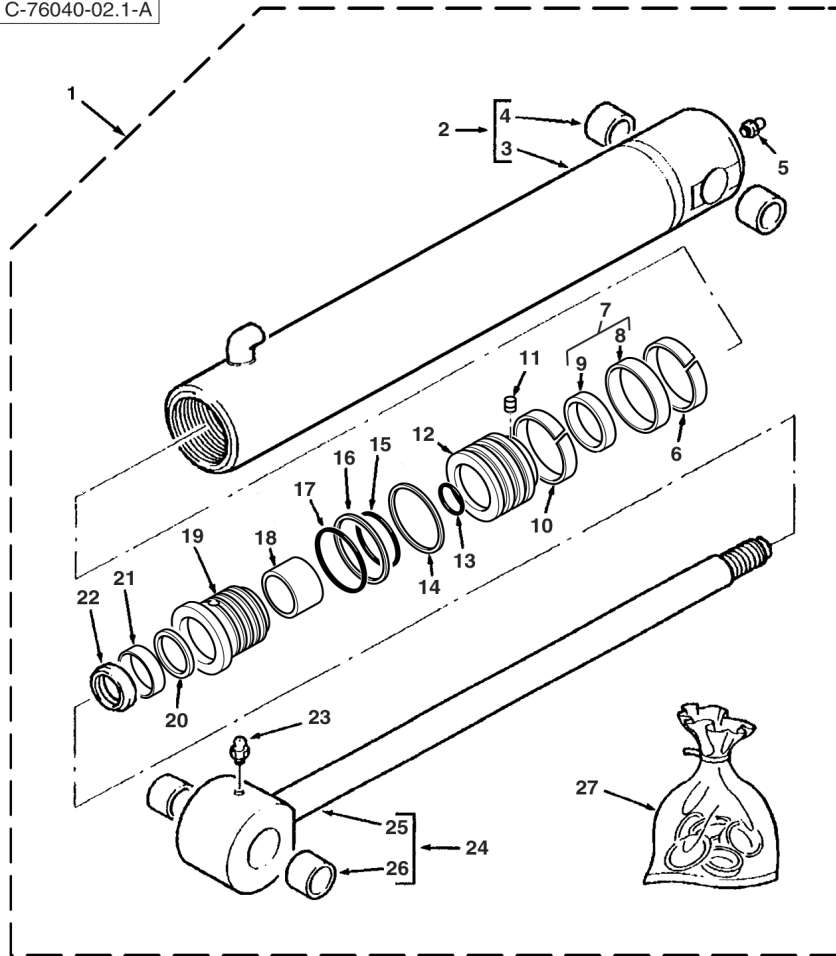

1	5000126M91		76040C01.1 1	1	Cylinder Assy	Ensemble de vérin	Gato, Conj.
2	5004008M91	1		1	Cylinder	Cylindre	Cilindro
3		3	Ref. 2	1	Tube, Cylinder	Cylindre de vérin	Cilindro de gato
4		3 (C)		1	Bushing	Bague	Anillo
5	339608X1	1		1	Fitting, Grease	Graisser	Engrasador
6	3485892M1	1 (A)		1	Ring, Sealing	Bague d'étanchéité	Anillo, Estanqueidad
7	3485245M91	1 (A)		1	Seal Assy	Ensemble de joint	Junta, Conj.
8		7	Ref. 7	1	Seal	Joint	Junta
9		7	Ref. 7	1	Ring	Anneau	Aro
10	3485892M1	1 (A)		1	Ring, Sealing	Bague d'étanchéité	Anillo, Estanqueidad
11	3402928M1	1		1	Screw	Vis	Tornillo
12	3623372M1	1		1	Piston	Piston	Pistón
13	359186X1	1 (A)		1	O-Ring	Joint torique	Junta de tipo O
14	3623061M1	1		1	Ring, Piston	Segment de piston	Segmento de pistón
15	359193X1	1 (A)		1	O-Ring	Joint torique	Junta de tipo O
16	1606735M1	1 (A)		1	Ring, Backup	Contre-joint	ContraJunta
17	3487207M1	1 (A)		1	O-Ring	Joint torique	Junta de tipo O
18	3484615M1	1 (A)		1	Ring	Anneau	Aro
19	3623371M1	1		1	Bearing	Coussinet	Cojinete
20	3484055M1	1 (A)		1	Ring	Anneau	Aro
21	3485185M1	1 (A)		1	Seal	Joint	Junta
22	3487015M1	1 (A)		1	Ring	Anneau	Aro
23	339608X1	1		1	Fitting, Grease	Graisser	Engrasador
24	5004012M91	1		1	Rod, Piston	Tige de vérin	Vástago cilindro
25		24	Ref. 24	1	Rod, Piston	Tige de vérin	Vástago cilindro
26		24 (C)		1	Bushing	Bague	Anillo
27	3623373M91		(B)	1	Kit, Seal	Pochette de joints	Juego de juntas

A Contains items marked (A)
 Comprend les pièces marquées (A)
 Incluye las piezas marcadas (A)

C Part number to be advised
 Référence pièce à demander
 Indicar número de pieza

B Included in kit marked (B)
 Inclus dans jeu marqué (B)
 Incluido en juego marcado (B)



860 880 970
 TX860B

809 810 813 814 821 822 841 842 851 852 922

76040C02.1

6199042M3

1

Jan-06

Digger Hydraulics
Circuit Hydraulique Défonceuse
Circuito hidráulico equipo retro

Centremount
Montage de Pelle Central
Excavadora de montaje central

Standard Dipper
Balancier Standard
Balancín estándar

High Spec.
 High Spec.
 High Spec.

C-76040-03.1-A

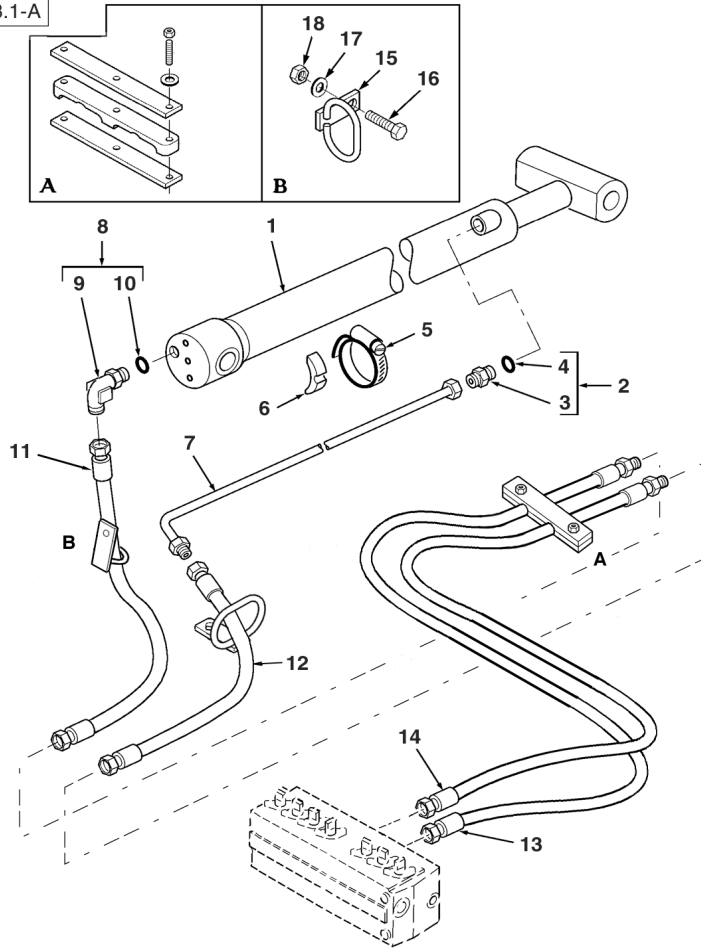

1	5000124M91	76040C04.1 1	1	Cylinder Assy	Ensemble de vérin	Gato, Conj.
2	835013M91		1	Connector Assy	Ensemble connexion	Conexión, Conj.
3		2 Ref. 2	1	Union	Union	Unión
4	835024M1	2	1	O-Ring	Joint torique	Junta de tipo O
5	3517733M1		1	Clamp	Collier de serrage	Argolla de cierre
6	L79937		1	Spacer	Entretoise	Travesa
7	6100976M92	(A)	1	Tube Assy	Tuyauterie	Conjunto de tubería
8	6101624M91	(A)	1	Elbow, 90°	Coude à 90°	Codo, 90°
9		8 (A)	1	Elbow	Coude	Codo
10	835024M1	8 (A)	1	O-Ring	Joint torique	Junta de tipo O
11	6101738M91	Yellow	1	Hose Assy	Ensemble de flexible	Flexible, Conj.
12	6101737M91	Red	1	Hose Assy	Ensemble de flexible	Flexible, Conj.
13	6102941M91	Yellow	1	Hose Assy	Ensemble de flexible	Flexible, Conj.
14	6102944M91	Red	1	Hose Assy	Ensemble de flexible	Flexible, Conj.
15	6101491M92		2	Support Assy	Ensemble de support	Apoyadero, Conj.
16	339761X1	M8 x 25	2	Screw	Vis	Tornillo
17	390972X1	M8	2	Washer	Rondelle	Arandela
18	394367X1	M8	2	Nut, Lock	Écrou de blocage	Tuerca de retención

A Without Hose Burst
 Sans éclatement de tuyau
 Sin rotura de tubo flexible



860 880 970
 TX860B

809 810 813 814 821 822 841 842 851 852 922

76040C03.1

6199042M3

1

Jan-06

Digger Hydraulics
Circuit Hydraulique Défonceuse
Circuito hidráulico equipo retro

Centremount
Montage de Pelle Central
Excavadora de montaje central

Dipper Cylinder
Vérin de Balancier
Gato de balancín

High Spec.
 High Spec.
 High Spec.

C-76040-04.1-A

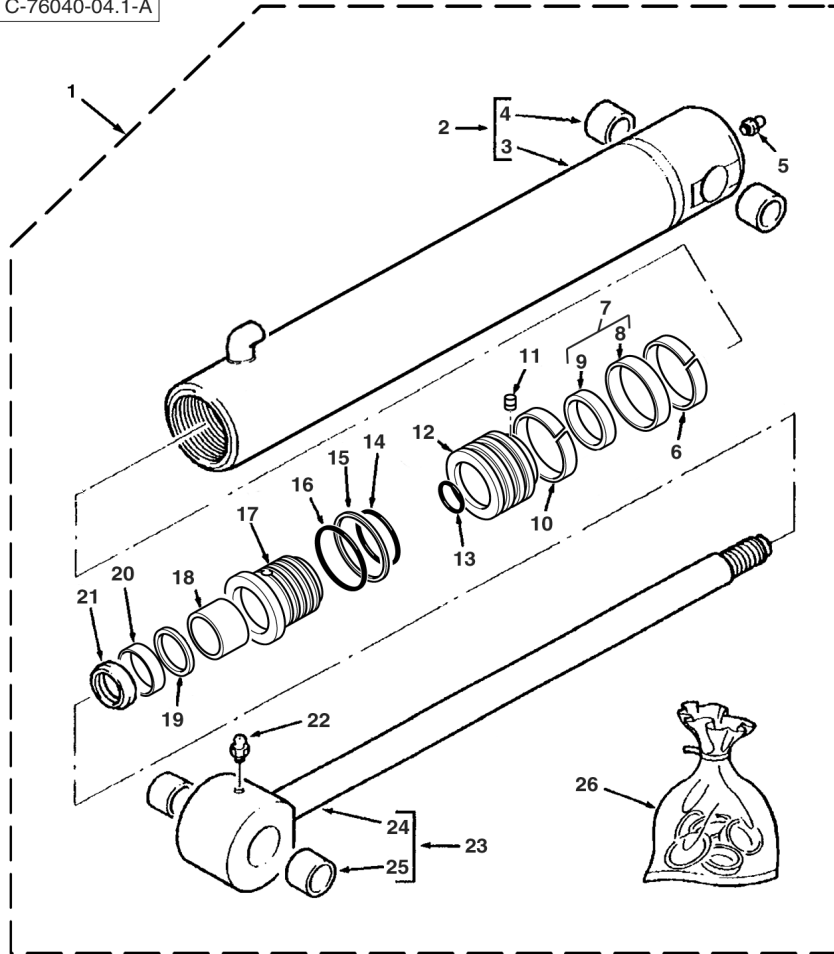

1	5000124M91	76040C03.1 1	1	Cylinder Assy	Ensemble de vérin	Gato, Conj.
2	5003982M91	1	1	Cylinder	Cylindre	Cilindro
3		2	1	Tube, Cylinder	Cylindre de vérin	Cilindro de gato
4	3484843M1	2	1	Bush	Bague	Casquillo
5	339608X1	1	1	Fitting, Grease	Graisneur	Engrasador
6	3485891M1	1 (A)	1	Ring	Anneau	Aro
7	3485247M91	1 (A)	1	Seal Assy	Ensemble de joint	Junta, Conj.
8		7	1	Seal	Joint	Junta
9		7	1	Ring	Anneau	Aro
10	3485891M1	1 (A)	1	Ring	Anneau	Aro
11	3402928M1	1	1	Screw	Vis	Tornillo
12	5003989M1	1	1	Piston	Piston	Pistón
13	3007182X1	1 (A)	1	O-Ring	Joint torique	Junta de tipo O
14	359196X1	1 (A)	1	O-Ring	Joint torique	Junta de tipo O
15	378545X1	1 (A)	1	Ring	Anneau	Aro
16	3487908M1	1 (A)	1	O-Ring	Joint torique	Junta de tipo O
17	5003988M1	1	1	Bearing	Coussinet	Cojinete
18	3623193M1	1 (A)	1	Ring	Anneau	Aro
19	3443388M1	1 (A)	1	Ring	Anneau	Aro
20	3443472M1	1 (A)	1	Seal	Joint	Junta
21	3403385M1	1 (A)	1	Ring, Wiper	Joint de racler	Junta raspador
22	339608X1	1	1	Fitting, Grease	Graisneur	Engrasador
23	5003985M91	1	1	Rod, Piston	Tige de vérin	Vástago cilindro
24		23	1	Rod, Piston	Tige de vérin	Vástago cilindro
25	3484843M1	23	1	Bush	Bague	Casquillo
26	5004401M91	(B)	1	Kit, Seal	Pochette de joints	Juego de juntas

A Included in kit marked (B)
 Inclus dans jeu marqué (B)
 Incluido en juego marcado (B)

B Contains items marked (A)
 Comprend les pièces marquées (A)
 Incluye las piezas marcadas (A)



860 880 970
 TX860B

809 810 813 814 821 822 841 842 851 852 922

76040C04.1

6199042M3

1

Jan-06

Digger Hydraulics
Circuit Hydraulique Défonceuse
Circuito hidráulico equipo retro

Centremount
Montage de Pelle Central
Excavadora de montaje central

Boom 4.5m
 Flèche 4.5m
 Pluma 4.5m

High Spec.
 High Spec.
 High Spec.

C-76040-05.1-A

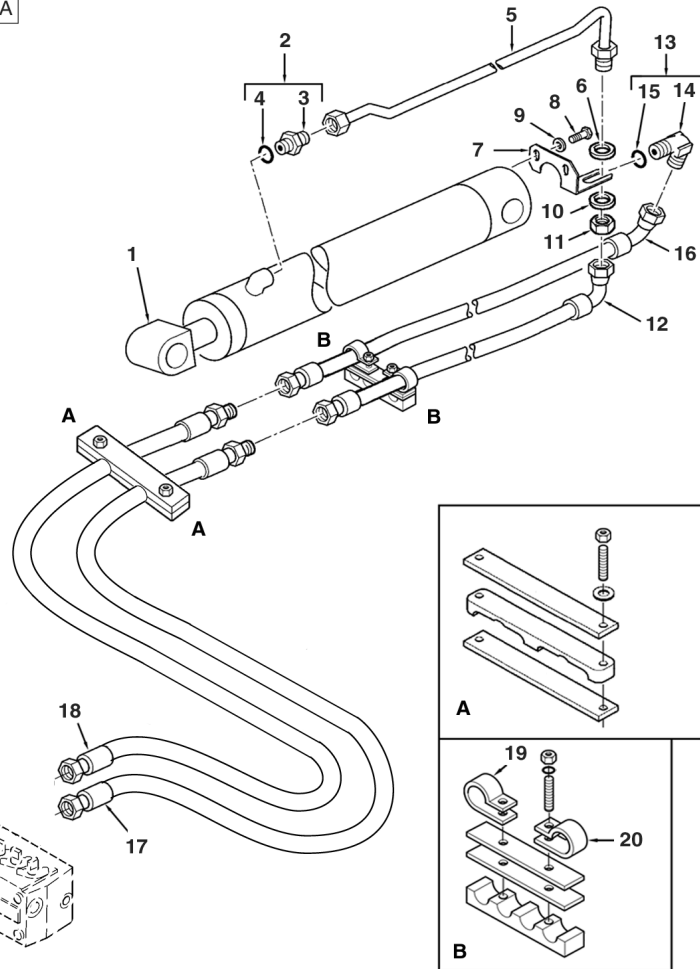

1	5000122M91	76040C06.1 1 4.5m Boom	1	Cylinder Assy	Ensemble de vérin	Gato, Conj.
2	835013M91		1	Connector Assy	Ensemble connexion	Conexión, Conj.
3		Ref. 2	1	Union	Union	Unión
4	835024M1		1	O-Ring	Joint torique	Junta de tipo O
5	6100855M91	(A)	1	Tube Assy	Tuyauterie	Conjunto de tubería
6	353763X1	(A)	1	Washer	Rondelle	Arandela
7	6100883M1	(A)	1	Bracket	Patte de fixation	Pata de fijación
8	339228X1	M8 x 12	2	Screw	Vis	Tornillo
9	339374X1	M8	2	Washer, Lock	Rondelle de blocage	Arandela de freno
10	353763X1	(A)	1	Washer	Rondelle	Arandela
11	355574X1	(A)	1	Nut	Écrou	Tuerca
12	6101735M92	(A)Orange	1	Hose Assy	Ensemble de flexible	Flexible, Conj.
13	835007M91	(A)	1	Elbow, 90°	Coude à 90°	Codo, 90°
14		Ref. 13	1	Elbow	Coude	Codo
15	835024M1		1	O-Ring	Joint torique	Junta de tipo O
16	6101736M92	Blue	1	Hose Assy	Ensemble de flexible	Flexible, Conj.
17	6102943M91	Orange	1	Hose Assy	Ensemble de flexible	Flexible, Conj.
18	6102940M91	Blue	1	Hose Assy	Ensemble de flexible	Flexible, Conj.
19	515-23270		1	Clip	Clip	Clip
20	515-23206		1	Clip	Clip	Clip

A Without Hose Burst
 Sans éclatement de tuyau
 Sin rotura de tubo flexible



860 880 970
 TX860B

809 810 813 814 821 822 841 842 851 852 922

76040C05.1

6199042M3

1

Jan-06

Digger Hydraulics
Circuit Hydraulique Défonceuse
Circuito hidráulico equipo retro

Centremount
Montage de Pelle Central
Excavadora de montaje central

Boom Cylinder
Vérin de Flèche
Gato de pluma

High Spec.
High Spec.
High Spec.

C-76040-06.1-A

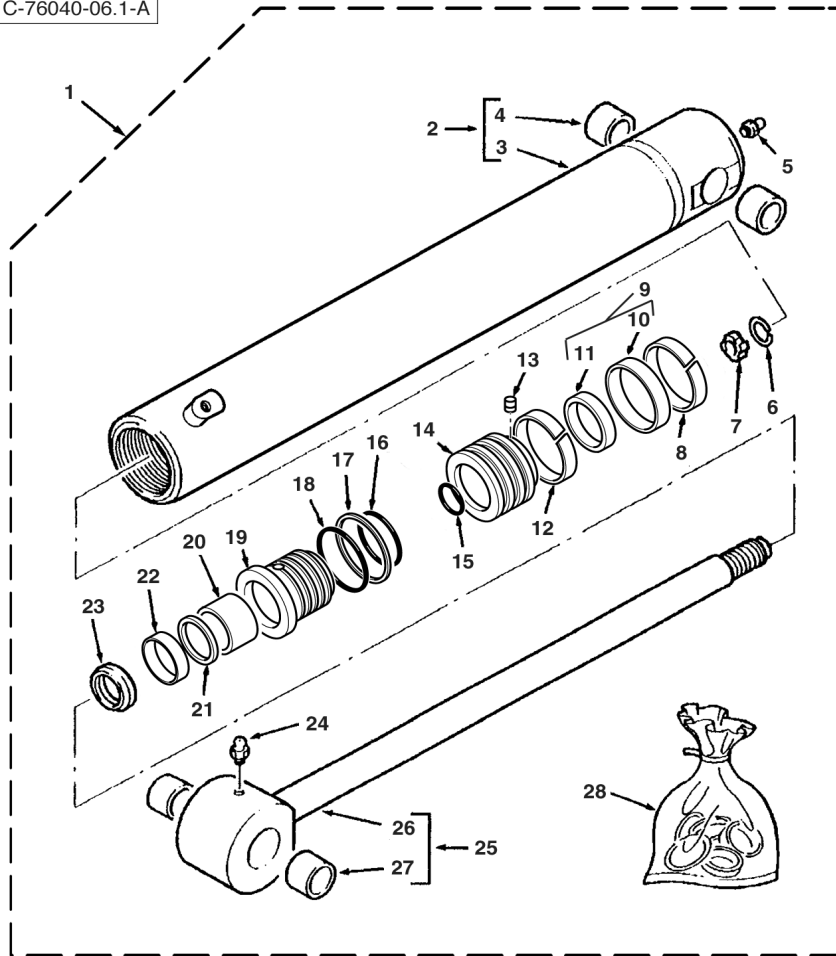

1	5000122M91	76040C05.1 1 4.5m Boom	1	Cylinder Assy	Ensemble de vérin	Gato, Conj.
2	5003912M91	1	1	Cylinder	Cylindre	Cilindro
3		2 Ref. 2	1	Tube, Cylinder	Cylindre de vérin	Cilindro de gato
4		2 (C)	2	Bushing	Bague	Anillo
5	339608X1	1	1	Fitting, Grease	Graisser	Engrasador
6	1609899M1	1	1	Ring, Snap	Anneau d'arrêt	Anillo de resorte
7	1609328M1	1	1	Ring	Anneau	Aro
8	3403852M1	1 (A)	1	Ring	Anneau	Aro
9	3485213M91	1 (A)	1	Seal Assy	Ensemble de joint	Junta, Conj.
10		9 Ref. 9	1	Seal	Joint	Junta
11		9 Ref. 9	1	Seal	Joint	Junta
12	3403852M1	1	1	Ring	Anneau	Aro
13	3402928M1	1	1	Screw	Vis	Tornillo
14	3484189M1	1	1	Piston	Piston	Pistón
15	3007182X1	1 (A)	1	O-Ring	Joint torique	Junta de tipo O
16	359203X1	1 (A)	1	O-Ring	Joint torique	Junta de tipo O
17	367120X1	1 (A)	1	Ring	Anneau	Aro
18	3487909M1	1 (A)	1	O-Ring	Joint torique	Junta de tipo O
19	3623202M1	1	1	Bearing	Coussinet	Cojinete
20	3623193M1	1 (A)	1	Ring	Anneau	Aro
21	3443388M1	1 (A)	1	Ring	Anneau	Aro
22	3443472M1	1 (A)	1	Seal	Joint	Junta
23	3403385M1	1 (A)	1	Ring, Wiper	Joint de racleur	Junta raspador
24	339608X1	1	1	Fitting, Grease	Graisser	Engrasador
25	3441629M91	1	1	Rod, Piston	Tige de vérin	Vástago cilindro
26		25 Ref. 25	1	Rod, Piston	Tige de vérin	Vástago cilindro
27	3484843M1	25	1	Bush	Bague	Casquillo
28	3623589M91	(B)	1	Kit, Seal	Pochette de joints	Juego de juntas

A Included in kit marked (B)
 Inclus dans jeu marqué (B)
 Incluido en juego marcado (B)

C Part number to be advised
 Référence pièce à demander
 Indicar número de pieza

B Contains items marked (A)
 Comprend les pièces marquées (A)
 Incluye las piezas marcadas (A)



860 880 970
 TX860B

809 810 813 814 821 822 841 842 851 852 922

76040C06.1

6199042M3

1

Jan-06

Digger Hydraulics
Circuit Hydraulique Défonceuse
Circuito hidráulico equipo retro

Centremount
Montage de Pelle Central
Excavadora de montaje central

Swing Components
Organes de Rotation
Componentes de rotación

High Spec.
 High Spec.
 High Spec.

C-76040-07.1-A

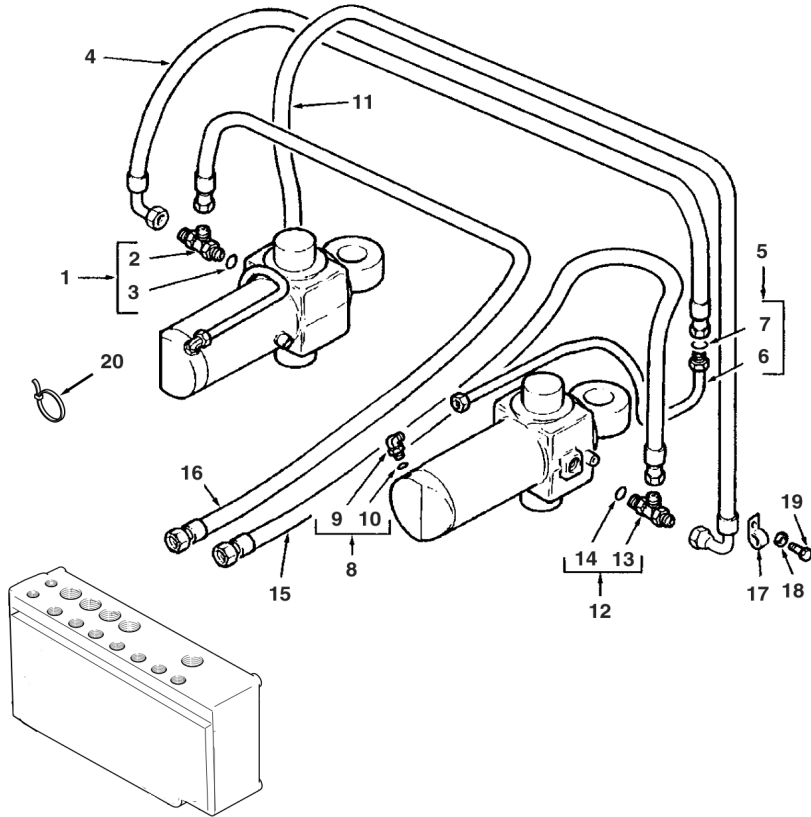

1	358728X91			1	Tee	Raccord en T	Te
2		1	▶ Ref. 1	1	Tee	Raccord en T	Te
3	831497M1	1		1	O-Ring	Joint torique	Junta de tipo O
4	6100716M91	840 mm		1	Hose Assy	Ensemble de flexible	Flexible, Conj.
5	6100587M91		◀	1	Tube Assy	Tuyauterie	Conjunto de tubería
5	6100589M91		▶	1	Tube Assy	Tuyauterie	Conjunto de tubería
6		5	▶ Ref. 5	1	Tube	Tube	Tubo
7	394923X1	5		1	O-Ring	Joint torique	Junta de tipo O
8	357197X91			2	Elbow, 90°	Coude à 90°	Codo, 90°
9		8	▶ Ref. 8	1	Elbow	Coude	Codo
10	831452M1	8		1	O-Ring	Joint torique	Junta de tipo O
11	6100716M91	840 mm		1	Hose Assy	Ensemble de flexible	Flexible, Conj.
12	358728X91			1	Tee	Raccord en T	Te
13		12	▶ Ref. 12	1	Tee	Raccord en T	Te
14	831497M1	12		1	O-Ring	Joint torique	Junta de tipo O
15	6100715M92	Purple 700mm		1	Hose Assy	Ensemble de flexible	Flexible, Conj.
16	6101866M93	Green 700mm		1	Hose Assy	Ensemble de flexible	Flexible, Conj.
17	3517114M2			2	Clip, Mounting	Collier de fixation	Argolla de fijación
18	385361X1	M8		2	Washer	Rondelle	Arandela
19	339228X1	M8 x 12		2	Screw	Vis	Tornillo
20	1862425M1			1	Tie, Cable	Attache câble	Enlace de Cable



860 880 970
 TX860B

809 810 813 814 821 822 841 842 851 852 922

76040C07.1

6199042M3

1

Jan-06

Digger Hydraulics
Circuit Hydraulique Défonceuse
Circuito hidráulico equipo retro

Centremount
Montage de Pelle Central
Excavadora de montaje central

Bucket
 Godet
 Cuchara

High Spec.
 High Spec.
 High Spec.

C-76041-01.1-A

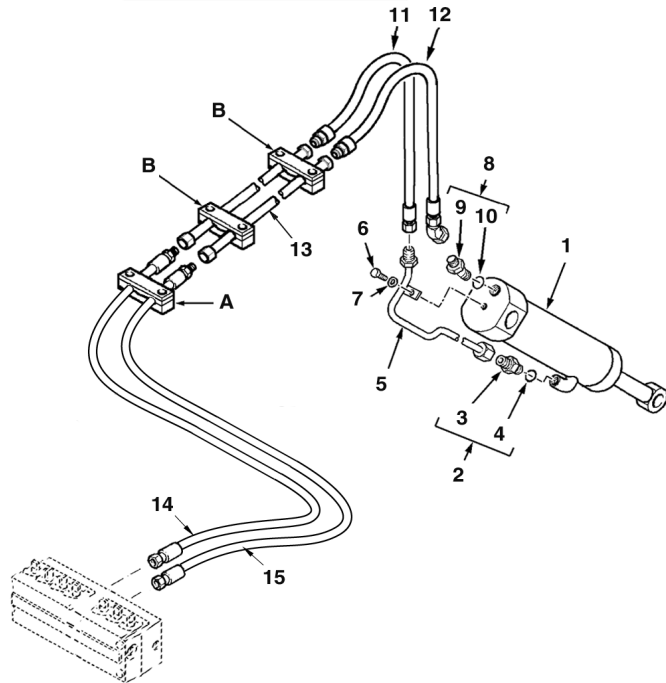
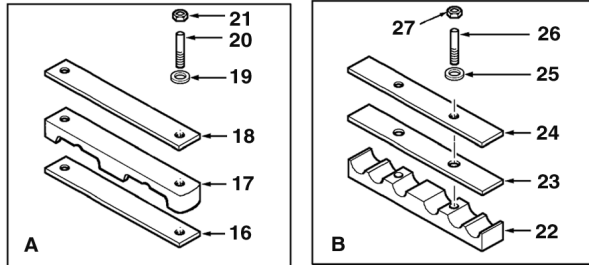

1	5000126M91	76041C02.1 1	1	Cylinder Assy	Ensemble de vérin	Gato, Conj.
2	835013M91		1	Connector Assy	Ensemble connexion	Conexión, Conj.
3		2 Ref. 2	1	Union	Union	Unión
4	835024M1	2	1	O-Ring	Joint torique	Junta de tipo O
5	6101540M91		1	Tube Assy	Tuyauterie	Conjunto de tubería
6	339123X1	M8 x 20	1	Bolt	Boulon	Perno
7	385361X1	M8	1	Washer	Rondelle	Arandela
8	835010M91		1	Elbow, 45°	Coude à 45°	Codo, 45°
9		8 Ref. 8	1	Elbow	Coude	Codo
10	835024M1	8	1	O-Ring	Joint torique	Junta de tipo O
11		(A)Brown	1	Hose Assy	Ensemble de flexible	Flexible, Conj.
12		(A)White	1	Hose Assy	Ensemble de flexible	Flexible, Conj.
13	6101771M91		2	Tube Assy	Tuyauterie	Conjunto de tubería
14	6102945M91	Brown	1	Hose Assy	Ensemble de flexible	Flexible, Conj.
15	6102942M91	White	1	Hose Assy	Ensemble de flexible	Flexible, Conj.
16	6102128M1		1	Pad	Plaque antidérapante	Cinta antideslizante
17	6102122M1		1	Bracket, Clamp	Bride de fixation	Brida de fijación
18	6102130M1		1	Plate	Plaque	Placa
19	390972X1	M8	2	Washer	Rondelle	Arandela
20	3516075M1	M8 x 65	2	Stud	Goujon	Espárrago
21	394367X1	M8	2	Nut, Lock	Écrou de blocage	Tuerca de retención
22	6102126M1		2	Bracket, Clamp	Bride de fixation	Brida de fijación
23	6102145M1		2	Pad	Plaque antidérapante	Cinta antideslizante
24	6102124M1		2	Plate	Plaque	Placa
25	390972X1	M8	4	Washer	Rondelle	Arandela
26	6108049M1		4	Stud	Goujon	Espárrago
27	394367X1	M8	4	Nut, Lock	Écrou de blocage	Tuerca de retención

A See extendahoe hydraulics section
 Voir la section circuit hydraulique extendahoe
 Ver la sección de la circuito hidráulico extendahoe



860 880 970
 TX860B

809 810 813 814 821 822 841 842 851 852 922

76041C01.1

6199042M3

1

Jan-06

Digger Hydraulics
Circuit Hydraulique Défonceuse
Circuito hidráulico equipo retro

Centremount
Montage de Pelle Central
Excavadora de montaje central

Bucket Cylinder
Vérin de Godet
Gato de cuchara

High Spec.
 High Spec.
 High Spec.

C-76041-02.1-A

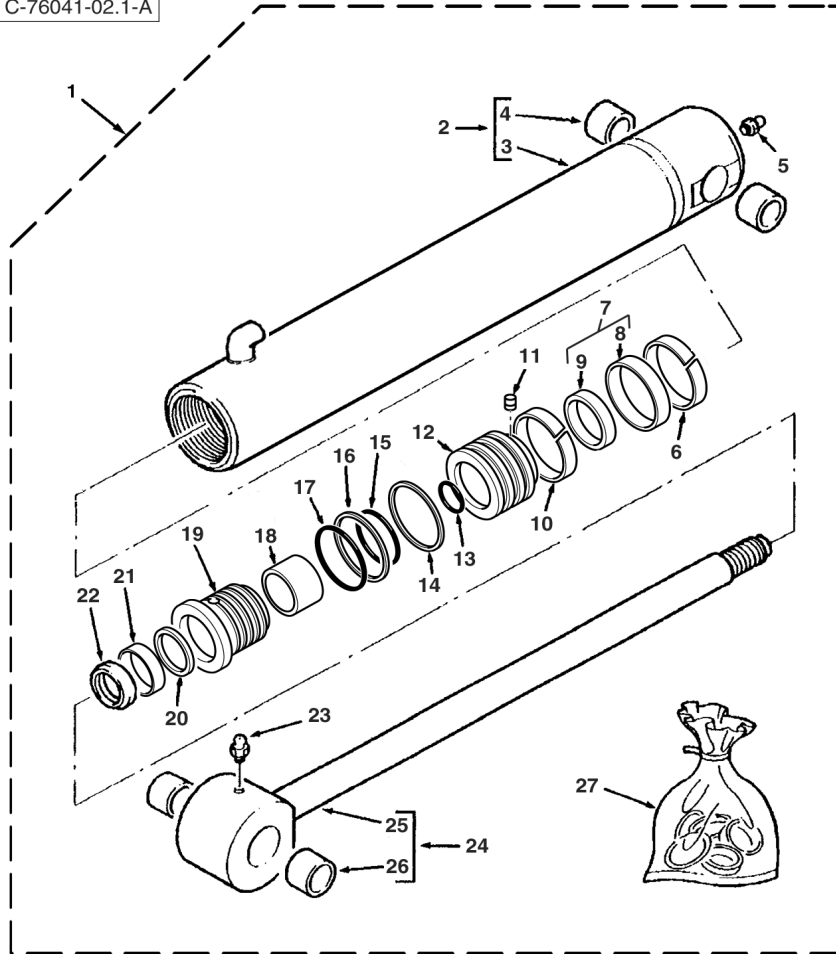

1	5000126M91		76041C01.1 1	1	Cylinder Assy	Ensemble de vérin	Gato, Conj.
2	5004008M91	1		1	Cylinder	Cylindre	Cilindro
3		3	Ref. 2	1	Tube, Cylinder	Cylindre de vérin	Cilindro de gato
4		3 (C)		1	Bushing	Bague	Anillo
5	339608X1	1		1	Fitting, Grease	Graisser	Engrasador
6	3485892M1	1 (A)		1	Ring, Sealing	Bague d'étanchéité	Anillo, Estanqueidad
7	3485245M91	1 (A)		1	Seal Assy	Ensemble de joint	Junta, Conj.
8		7	Ref. 7	1	Seal	Joint	Junta
9		7	Ref. 7	1	Ring	Anneau	Aro
10	3485892M1	1 (A)		1	Ring, Sealing	Bague d'étanchéité	Anillo, Estanqueidad
11	3402928M1	1		1	Screw	Vis	Tornillo
12	3623372M1	1		1	Piston	Piston	Pistón
13	359186X1	1 (A)		1	O-Ring	Joint torique	Junta de tipo O
14	3623061M1	1		1	Ring, Piston	Segment de piston	Segmento de pistón
15	359193X1	1 (A)		1	O-Ring	Joint torique	Junta de tipo O
16	1606735M1	1 (A)		1	Ring, Backup	Contre-joint	ContraJunta
17	3487207M1	1 (A)		1	O-Ring	Joint torique	Junta de tipo O
18	3484615M1	1 (A)		1	Ring	Anneau	Aro
19	3623371M1	1		1	Bearing	Coussinet	Cojinete
20	3484055M1	1 (A)		1	Ring	Anneau	Aro
21	3485185M1	1 (A)		1	Seal	Joint	Junta
22	3487015M1	1 (A)		1	Ring	Anneau	Aro
23	339608X1	1		1	Fitting, Grease	Graisser	Engrasador
24	5004012M91	1		1	Rod, Piston	Tige de vérin	Vástago cilindro
25		24	Ref. 24	1	Rod, Piston	Tige de vérin	Vástago cilindro
26		24 (C)		1	Bushing	Bague	Anillo
27	3623373M91		(B)	1	Kit, Seal	Pochette de joints	Juego de juntas

A Contains items marked (A)
 Comprend les pièces marquées (A)
 Incluye las piezas marcadas (A)

C Part number to be advised
 Référence pièce à demander
 Indicar número de pieza

B Included in kit marked (B)
 Inclus dans jeu marqué (B)
 Incluido en juego marcado (B)



860 880 970
 TX860B

809 810 813 814 821 822 841 842 851 852 922

76041C02.1

6199042M3

1

Jan-06

Digger Hydraulics
Circuit Hydraulique Défonceuse
Circuito hidráulico equipo retro

Centremount
Montage de Pelle Central
Excavadora de montaje central

Telescopic Dipper
Balancier Téléscopique
Balancín telescópico

High Spec.
 High Spec.
 High Spec.

C-76041-03.1-A

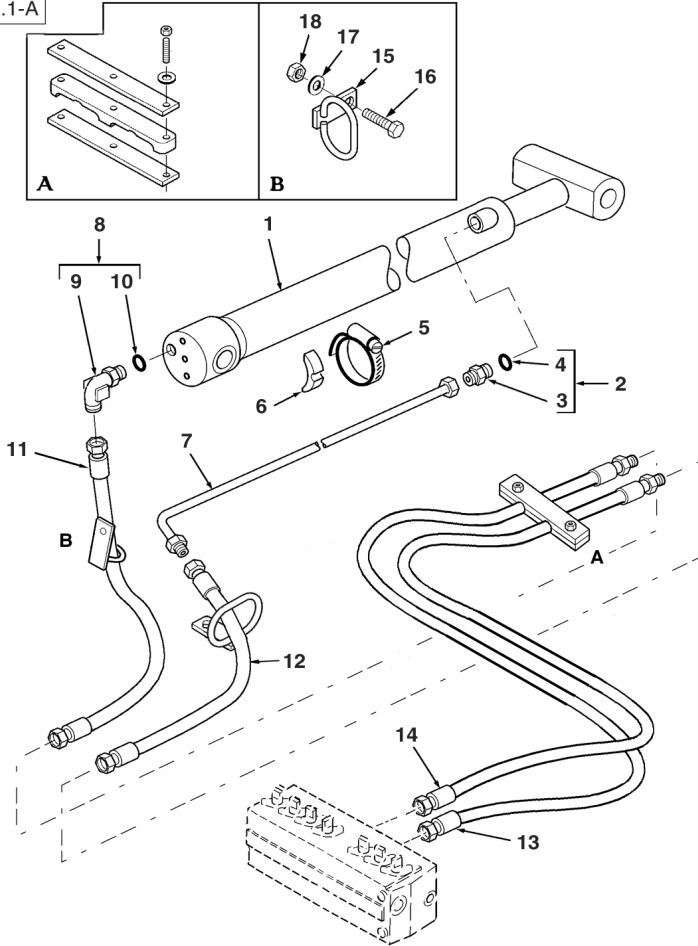

1	5000124M91	76041C04.1 1	1	Cylinder Assy	Ensemble de vérin	Gato, Conj.
2	835013M91		1	Connector Assy	Ensemble connexion	Conexión, Conj.
3		2 Ref. 2	1	Union	Union	Unión
4	835024M1	2	1	O-Ring	Joint torique	Junta de tipo O
5	3517733M1		1	Clamp	Collier de serrage	Argolla de cierre
6	L79937		1	Spacer	Entretoise	Travesa
7	6100976M92	(A)	1	Tube Assy	Tuyauterie	Conjunto de tubería
8	6101624M91	(A)	1	Elbow, 90°	Coude à 90°	Codo, 90°
9		8 (A) Ref. 8	1	Elbow	Coude	Codo
10	835024M1	8 (A)	1	O-Ring	Joint torique	Junta de tipo O
11	6101738M91	Yellow	1	Hose Assy	Ensemble de flexible	Flexible, Conj.
12	6101737M91	Red	1	Hose Assy	Ensemble de flexible	Flexible, Conj.
13	6102941M91	Yellow	1	Hose Assy	Ensemble de flexible	Flexible, Conj.
14	6102944M91	Red	1	Hose Assy	Ensemble de flexible	Flexible, Conj.
15	6101491M92		2	Support Assy	Ensemble de support	Apoyadero, Conj.
16	339761X1	M8 x 25	2	Screw	Vis	Tornillo
17	390972X1	M8	2	Washer	Rondelle	Arandela
18	394367X1	M8	2	Nut, Lock	Écrou de blocage	Tuerca de retención

A Without Hose Burst
 Sans éclatement de tuyau
 Sin rotura de tubo flexible



860 880 970
 TX860B

809 810 813 814 821 822 841 842 851 852 922

76041C03.1

6199042M3

1

Jan-06

Digger Hydraulics
Circuit Hydraulique Défonceuse
Circuito hidráulico equipo retro

Centremount
Montage de Pelle Central
Excavadora de montaje central

Dipper Cylinder
Vérin de Balancier
Gato de balancín

High Spec.
 High Spec.
 High Spec.

C-76041-04.1-A

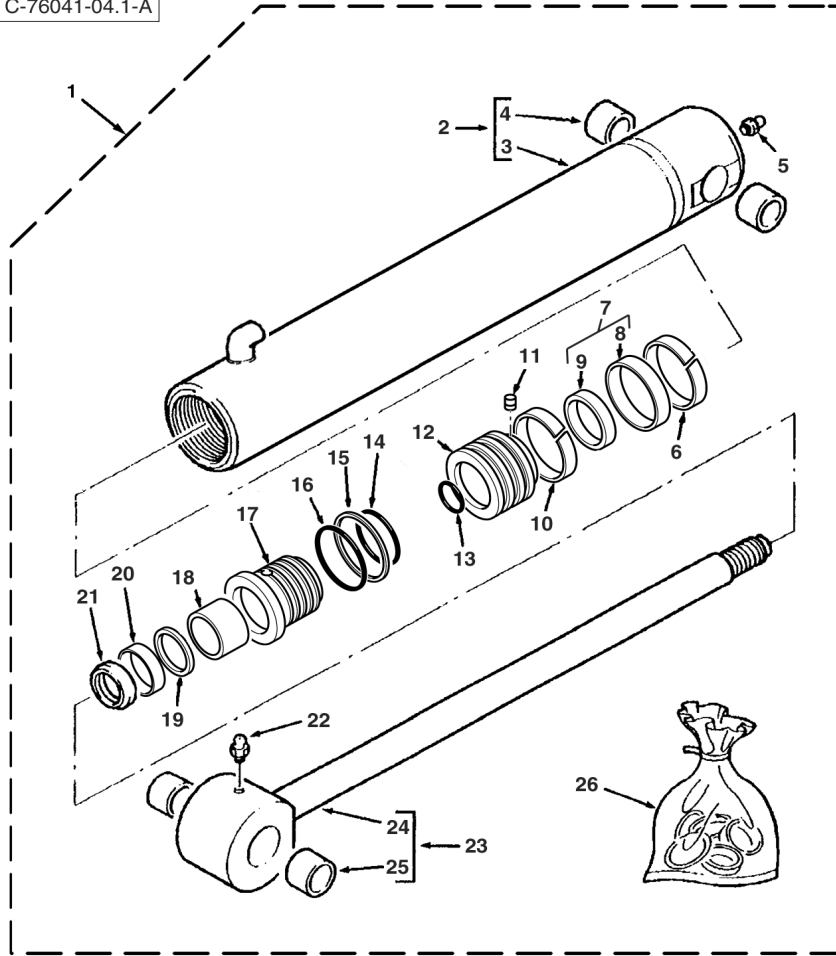

1	5000124M91		76041C03.1 1	1	Cylinder Assy	Ensemble de vérin	Gato, Conj.
2	5003982M91	1		1	Cylinder	Cylindre	Cilindro
3		2	Ref. 2	1	Tube, Cylinder	Cylindre de vérin	Cilindro de gato
4	3484843M1	2		1	Bush	Bague	Casquillo
5	339608X1	1		1	Fitting, Grease	Graisneur	Engrasador
6	3485891M1	1 (A)		1	Ring	Anneau	Aro
7	3485247M91	1 (A)		1	Seal Assy	Ensemble de joint	Junta, Conj.
8		7	Ref. 7	1	Seal	Joint	Junta
9		7	Ref. 7	1	Ring	Anneau	Aro
10	3485891M1	1 (A)		1	Ring	Anneau	Aro
11	3402928M1	1		1	Screw	Vis	Tornillo
12	5003989M1	1		1	Piston	Piston	Pistón
13	3007182X1	1 (A)		1	O-Ring	Joint torique	Junta de tipo O
14	359196X1	1 (A)		1	O-Ring	Joint torique	Junta de tipo O
15	378545X1	1 (A)		1	Ring	Anneau	Aro
16	3487908M1	1 (A)		1	O-Ring	Joint torique	Junta de tipo O
17	5003988M1	1		1	Bearing	Coussinet	Cojinete
18	3623193M1	1 (A)		1	Ring	Anneau	Aro
19	3443388M1	1 (A)		1	Ring	Anneau	Aro
20	3443472M1	1 (A)		1	Seal	Joint	Junta
21	3403385M1	1 (A)		1	Ring, Wiper	Joint de racler	Junta raspador
22	339608X1	1		1	Fitting, Grease	Graisneur	Engrasador
23	5003985M91	1		1	Rod, Piston	Tige de vérin	Vástago cilindro
24		23	Ref. 23	1	Rod, Piston	Tige de vérin	Vástago cilindro
25	3484843M1	23		1	Bush	Bague	Casquillo
26	5004401M91		(B)	1	Kit, Seal	Pochette de joints	Juego de juntas

A Included in kit marked (B)
 Inclus dans jeu marqué (B)
 Incluido en juego marcado (B)

B Contains items marked (A)
 Comprend les pièces marquées (A)
 Incluye las piezas marcadas (A)



860 880 970
 TX860B

809 810 813 814 821 822 841 842 851 852 922

76041C04.1

6199042M3

1

Jan-06

Digger Hydraulics
Circuit Hydraulique Défonceuse
Circuito hidráulico equipo retro

Centremount
Montage de Pelle Central
Excavadora de montaje central

Boom 4.5m
 Flèche 4.5m
 Pluma 4.5m

High Spec.
 High Spec.
 High Spec.

C-76041-05.1-A

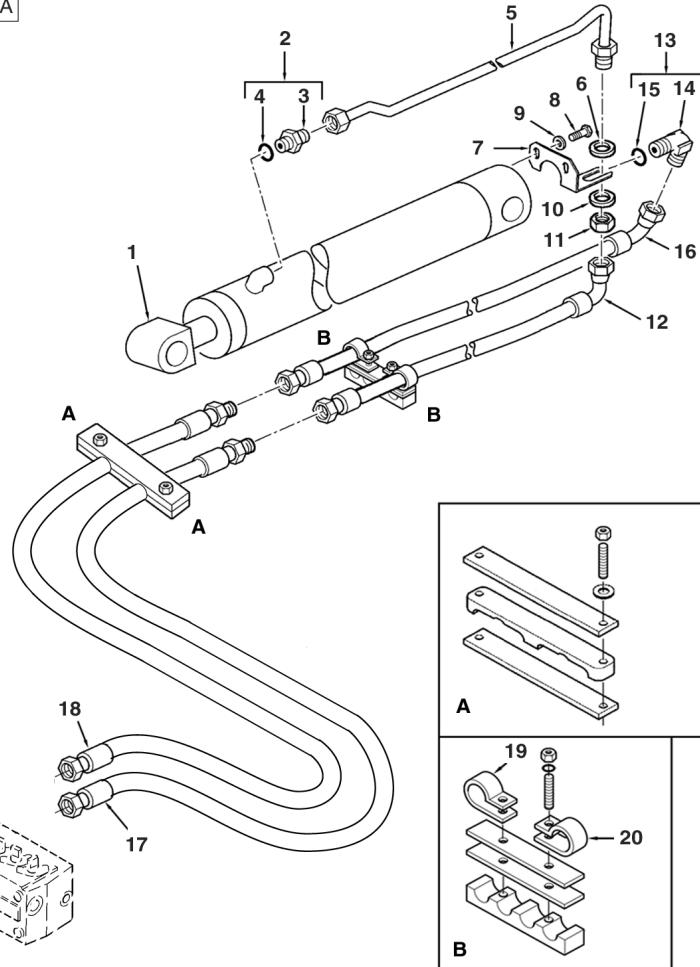

1	5000122M91	76041C06.1 1 4.5m Boom	1	Cylinder Assy	Ensemble de vérin	Gato, Conj.
2	835013M91		1	Connector Assy	Ensemble connexion	Conexión, Conj.
3		Ref. 2	1	Union	Union	Unión
4	835024M1		1	O-Ring	Joint torique	Junta de tipo O
5	6100855M91	(A)	1	Tube Assy	Tuyauterie	Conjunto de tubería
6	353763X1	(A)	1	Washer	Rondelle	Arandela
7	6100883M1	(A)	1	Bracket	Patte de fixation	Pata de fijación
8	339228X1	M8 x 12	2	Screw	Vis	Tornillo
9	339374X1	M8	2	Washer, Lock	Rondelle de blocage	Arandela de freno
10	353763X1	(A)	1	Washer	Rondelle	Arandela
11	355574X1	(A)	1	Nut	Écrou	Tuerca
12	6101735M92	(A)Orange	1	Hose Assy	Ensemble de flexible	Flexible, Conj.
13	835007M91	(A)	1	Elbow, 90°	Coude à 90°	Codo, 90°
14		Ref. 13	1	Elbow	Coude	Codo
15	835024M1		1	O-Ring	Joint torique	Junta de tipo O
16	6101736M92	Blue	1	Hose Assy	Ensemble de flexible	Flexible, Conj.
17	6102943M91	Orange	1	Hose Assy	Ensemble de flexible	Flexible, Conj.
18	6102940M91	Blue	1	Hose Assy	Ensemble de flexible	Flexible, Conj.
19	515-23270		1	Clip	Clip	Clip
20	515-23206		1	Clip	Clip	Clip

A Without Hose Burst
 Sans éclatement de tuyau
 Sin rotura de tubo flexible



860 880 970
 TX860B

809 810 813 814 821 822 841 842 851 852 922

76041C05.1

6199042M3

1

Jan-06

Digger Hydraulics
Circuit Hydraulique Défonceuse
Circuito hidráulico equipo retro

Centremount
Montage de Pelle Central
Excavadora de montaje central

Boom Cylinder
Vérin de Flèche
Gato de pluma

High Spec.
High Spec.
High Spec.

C-76041-06.1-A

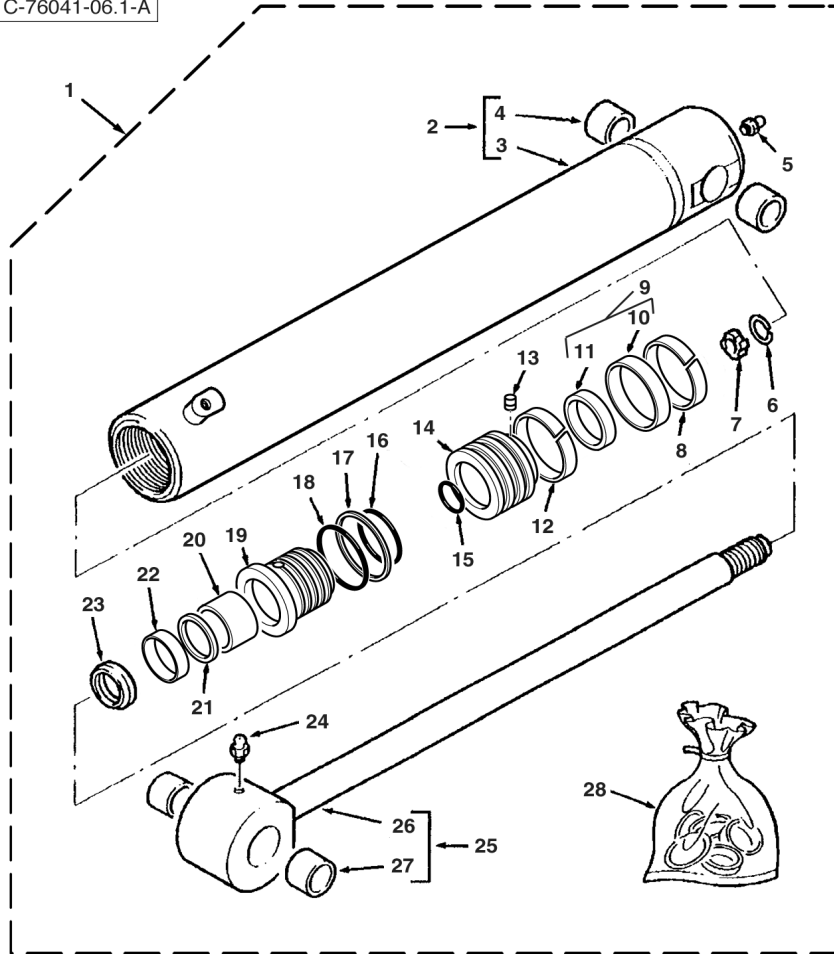

1	5000122M91	76041C05.1 1 4.5m Boom	1	Cylinder Assy	Ensemble de vérin	Gato, Conj.
2	5003912M91	1	1	Cylinder	Cylindre	Cilindro
3		2 Ref. 2	1	Tube, Cylinder	Cylindre de vérin	Cilindro de gato
4		(C)	2	Bushing	Bague	Anillo
5	339608X1	1	1	Fitting, Grease	Graisser	Engrasador
6	1609899M1	1	1	Ring, Snap	Anneau d'arrêt	Anillo de resorte
7	1609328M1	1	1	Ring	Anneau	Aro
8	3403852M1	1 (A)	1	Ring	Anneau	Aro
9	3485213M91	1 (A)	1	Seal Assy	Ensemble de joint	Junta, Conj.
10		9 Ref. 9	1	Seal	Joint	Junta
11		9 Ref. 9	1	Seal	Joint	Junta
12	3403852M1	1	1	Ring	Anneau	Aro
13	3402928M1	1	1	Screw	Vis	Tornillo
14	3484189M1	1	1	Piston	Piston	Pistón
15	3007182X1	1 (A)	1	O-Ring	Joint torique	Junta de tipo O
16	359203X1	1 (A)	1	O-Ring	Joint torique	Junta de tipo O
17	367120X1	1 (A)	1	Ring	Anneau	Aro
18	3487909M1	1 (A)	1	O-Ring	Joint torique	Junta de tipo O
19	3623202M1	1	1	Bearing	Coussinet	Cojinete
20	3623193M1	1 (A)	1	Ring	Anneau	Aro
21	3443388M1	1 (A)	1	Ring	Anneau	Aro
22	3443472M1	1 (A)	1	Seal	Joint	Junta
23	3403385M1	1 (A)	1	Ring, Wiper	Joint de racleur	Junta raspador
24	339608X1	1	1	Fitting, Grease	Graisser	Engrasador
25	3441629M91	1	1	Rod, Piston	Tige de vérin	Vástago cilindro
26		25 Ref. 25	1	Rod, Piston	Tige de vérin	Vástago cilindro
27	3484843M1	25	1	Bush	Bague	Casquillo
28	3623589M91	(B)	1	Kit, Seal	Pochette de joints	Juego de juntas

A Included in kit marked (B)
 Inclus dans jeu marqué (B)
 Incluido en juego marcado (B)

C Part number to be advised
 Référence pièce à demander
 Indicar número de pieza

B Contains items marked (A)
 Comprend les pièces marquées (A)
 Incluye las piezas marcadas (A)



860 880 970
 TX860B

809 810 813 814 821 822 841 842 851 852 922

76041C06.1

6199042M3

1

Jan-06

Digger Hydraulics
Circuit Hydraulique Défonceuse
Circuito hidráulico equipo retro

Centremount
Montage de Pelle Central
Excavadora de montaje central

Swing Components
Organes de Rotation
Componentes de rotación

High Spec.
 High Spec.
 High Spec.

C-76041-07.1-A

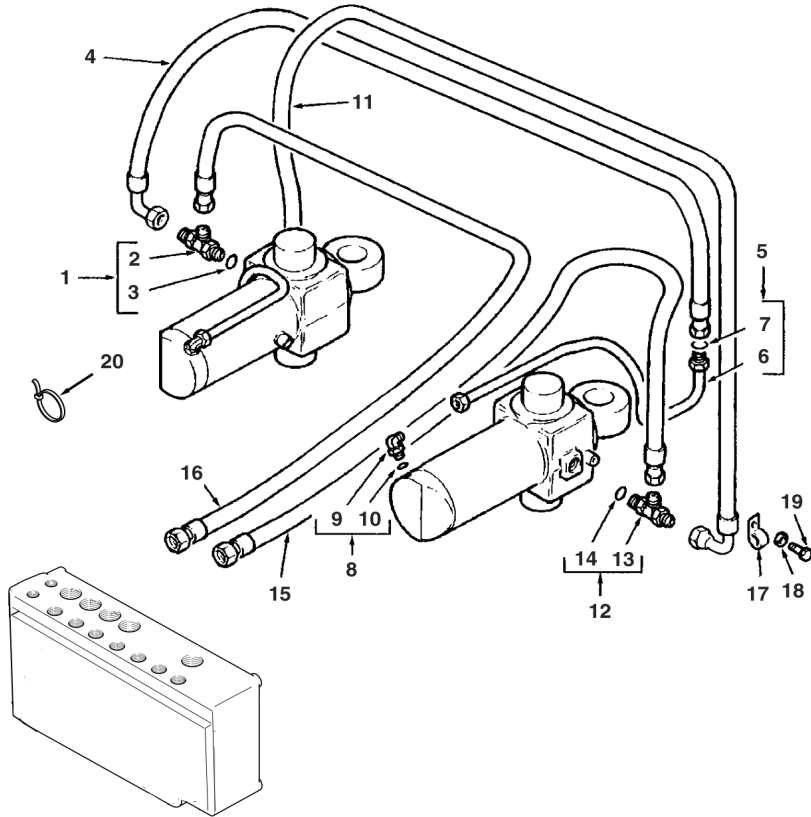

1	358728X91		1	Tee	Raccord en T	Te
2		1	▶ Ref. 1	1	Tee	Raccord en T
3	831497M1	1		1	O-Ring	Joint torique
4	6100716M91	840 mm		1	Hose Assy	Ensemble de flexible
5	6100587M91	▶		1	Tube Assy	Tuyauterie
5	6100589M91	▶		1	Tube Assy	Tuyauterie
6		5	▶ Ref. 5	1	Tube	Tube
7	394923X1	5		1	O-Ring	Joint torique
8	357197X91			2	Elbow, 90°	Coude à 90°
9		8	▶ Ref. 8	1	Elbow	Coude
10	831452M1	8		1	O-Ring	Joint torique
11	6100716M91	840 mm		1	Hose Assy	Ensemble de flexible
12	358728X91			1	Tee	Raccord en T
13		12	▶ Ref. 12	1	Tee	Raccord en T
14	831497M1	12		1	O-Ring	Joint torique
15	6100715M92	Purple 700mm		1	Hose Assy	Ensemble de flexible
16	6101866M93	Green 700mm		1	Hose Assy	Ensemble de flexible
17	3517114M2			2	Clip, Mounting	Collier de fixation
18	385361X1	M8		2	Washer	Rondelle
19	339228X1	M8 x 12		2	Screw	Vis
20	1862425M1			1	Tie, Cable	Attache câble



860 880 970
 TX860B

809 810 813 814 821 822 841 842 851 852 922

76041C07.1

6199042M3

1

Jan-06

Digger Hydraulics
Circuit Hydraulique Défonceuse
Circuito hidráulico equipo retro

Centremount
Montage de Pelle Central
Excavadora de montaje central

Bucket
 Godet
 Cuchara

4.9m
 4.9m
 4.9m

C-76042-01.1-A

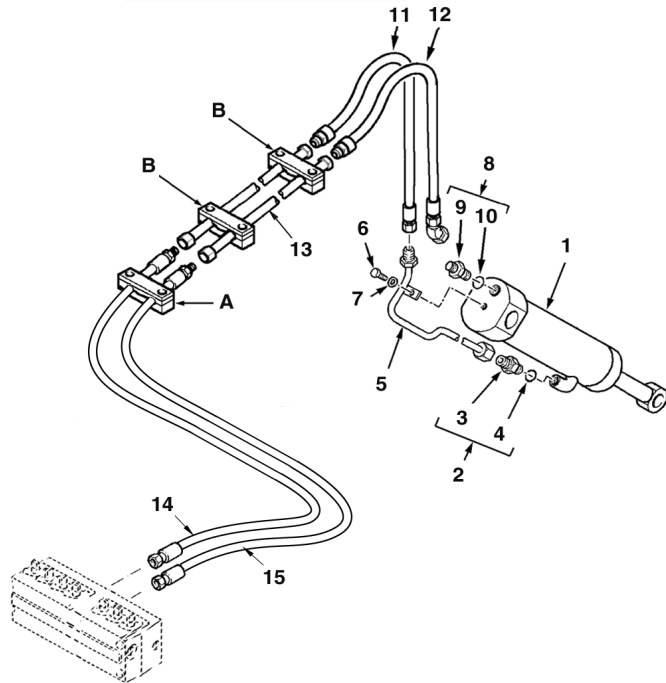
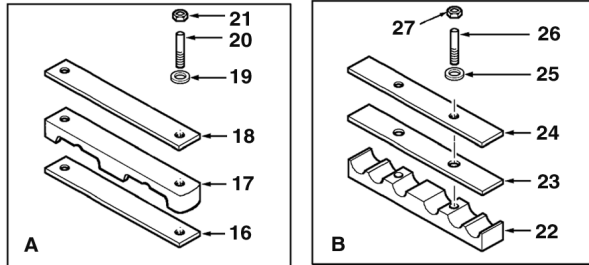

1	5000126M91	76042C02.1 1	1	Cylinder Assy	Ensemble de vérin	Gato, Conj.
2	835013M91		1	Connector Assy	Ensemble connexion	Conexión, Conj.
3		2 Ref. 2	1	Union	Union	Unión
4	835024M1	2	1	O-Ring	Joint torique	Junta de tipo O
5	6101540M91		1	Tube Assy	Tuyauterie	Conjunto de tubería
6	339123X1	M8 x 20	1	Bolt	Boulon	Perno
7	385361X1	M8	1	Washer	Rondelle	Arandela
8	835013M91		1	Connector Assy	Ensemble connexion	Conexión, Conj.
9		8 Ref. 8	1	Union	Union	Unión
10	835024M1	8	1	O-Ring	Joint torique	Junta de tipo O
11	6102309M91	Brown	1	Hose Assy	Ensemble de flexible	Flexible, Conj.
12	6107024M91	White	1	Hose Assy	Ensemble de flexible	Flexible, Conj.
13	6101431M91		2	Tube Assy	Tuyauterie	Conjunto de tubería
14	6102945M91	Brown	1	Hose Assy	Ensemble de flexible	Flexible, Conj.
15	6102942M91	White	1	Hose Assy	Ensemble de flexible	Flexible, Conj.
16	6102128M1		1	Pad	Plaque antidérapante	Cinta antideslizante
17	6102122M1		1	Bracket, Clamp	Bride de fixation	Brida de fijación
18	6102130M1		1	Plate	Plaque	Placa
19	390972X1	M8	2	Washer	Rondelle	Arandela
20	3516075M1	M8 x 65	2	Stud	Goujon	Espárrago
21	394367X1	M8	2	Nut, Lock	Écrou de blocage	Tuerca de retención
22	6102126M1		2	Bracket, Clamp	Bride de fixation	Brida de fijación
23	6102145M1		2	Pad	Plaque antidérapante	Cinta antideslizante
24	6102124M1		2	Plate	Plaque	Placa
25	390972X1	M8	4	Washer	Rondelle	Arandela
26	6108049M1		4	Stud	Goujon	Espárrago
27	394367X1	M8	4	Nut, Lock	Écrou de blocage	Tuerca de retención



860 880 970 980
 TX870B TX970B

811 812 815 816 823 824 843 844 853 854 923 932

76042C01.1

6199042M3

1

Jan-06

Digger Hydraulics
Circuit Hydraulique Défonceuse
Circuito hidráulico equipo retro

Centremount
Montage de Pelle Central
Excavadora de montaje central

Bucket Cylinder
Vérin de Godet
Gato de cuchara

4.9m
 4.9m
 4.9m

C-76042-02.1-A

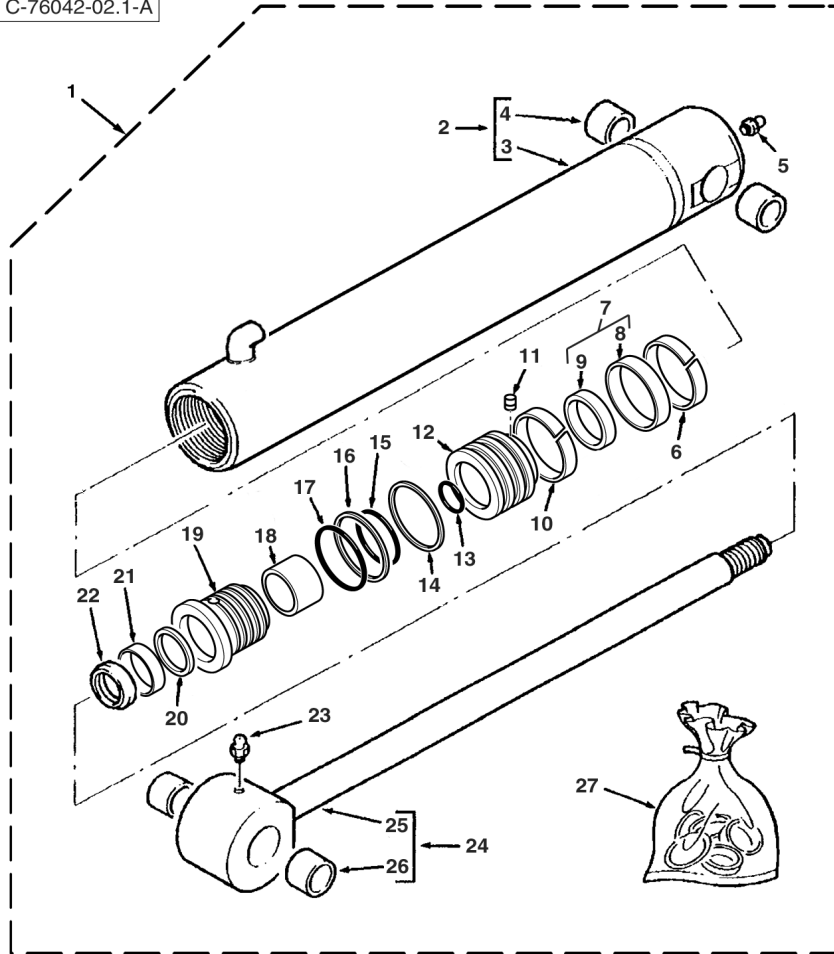

1	5000126M91		76042C01.1 1	1	Cylinder Assy	Ensemble de vérin	Gato, Conj.
2	5004008M91	1		1	Cylinder	Cylindre	Cilindro
3		3	Ref. 2	1	Tube, Cylinder	Cylindre de vérin	Cilindro de gato
4		3 (C)		1	Bushing	Bague	Anillo
5	339608X1	1		1	Fitting, Grease	Graisneur	Engrasador
6	3485892M1	1 (A)		1	Ring, Sealing	Bague d'étanchéité	Anillo, Estanqueidad
7	3485245M91	1 (A)		1	Seal Assy	Ensemble de joint	Junta, Conj.
8		7	Ref. 7	1	Seal	Joint	Junta
9		7	Ref. 7	1	Ring	Anneau	Aro
10	3485892M1	1 (A)		1	Ring, Sealing	Bague d'étanchéité	Anillo, Estanqueidad
11	3402928M1	1		1	Screw	Vis	Tornillo
12	3623372M1	1		1	Piston	Piston	Pistón
13	359186X1	1 (A)		1	O-Ring	Joint torique	Junta de tipo O
14	3623061M1	1		1	Ring, Piston	Segment de piston	Segmento de pistón
15	359193X1	1 (A)		1	O-Ring	Joint torique	Junta de tipo O
16	1606735M1	1 (A)		1	Ring, Backup	Contre-joint	ContraJunta
17	3487207M1	1 (A)		1	O-Ring	Joint torique	Junta de tipo O
18	3484615M1	1 (A)		1	Ring	Anneau	Aro
19	3623371M1	1		1	Bearing	Coussinet	Cojinete
20	3484055M1	1 (A)		1	Ring	Anneau	Aro
21	3485185M1	1 (A)		1	Seal	Joint	Junta
22	3487015M1	1 (A)		1	Ring	Anneau	Aro
23	339608X1	1		1	Fitting, Grease	Graisneur	Engrasador
24	5004012M91	1		1	Rod, Piston	Tige de vérin	Vástago cilindro
25		24	Ref. 24	1	Rod, Piston	Tige de vérin	Vástago cilindro
26		24 (C)		1	Bushing	Bague	Anillo
27	3623373M91		(B)	1	Kit, Seal	Pochette de joints	Juego de juntas

A Contains items marked (A)
 Comprend les pièces marquées (A)
 Incluye las piezas marcadas (A)

C Part number to be advised
 Référence pièce à demander
 Indicar número de pieza

B Included in kit marked (B)
 Inclus dans jeu marqué (B)
 Incluido en juego marcado (B)



860 880 970 980
 TX870B TX970B

811 812 815 816 823 824 843 844 853 854 923 932

76042C02.1

6199042M3

1

Jan-06

Digger Hydraulics
Circuit Hydraulique Défonceuse
Circuito hidráulico equipo retro

Centremount
Montage de Pelle Central
Excavadora de montaje central

Standard Dipper
Balancier Standard
Balancín estándar

4.9m
 4.9m
 4.9m

C-76042-03.1-A

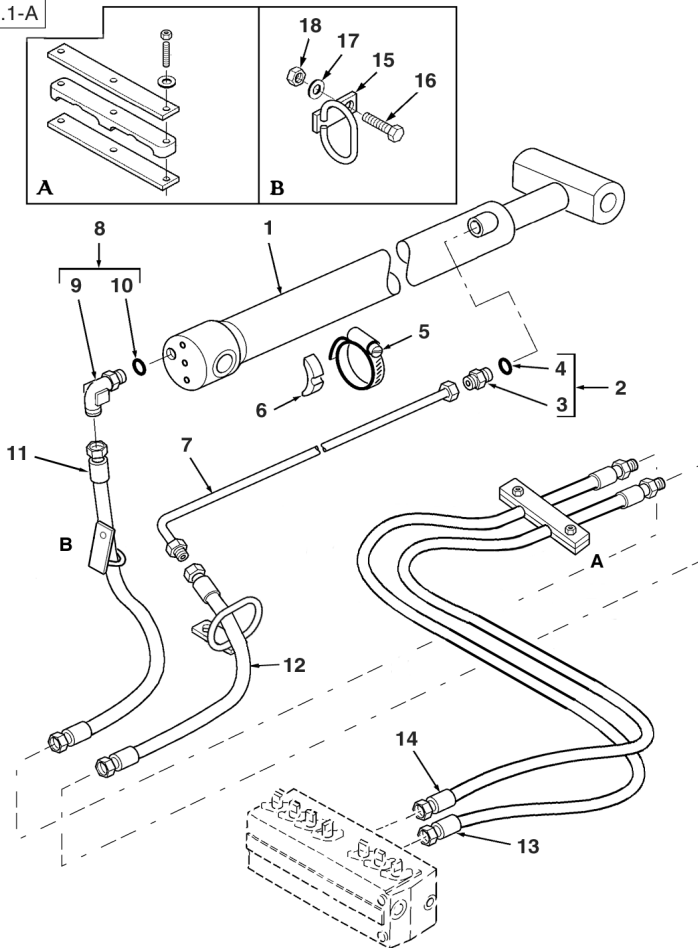

1	5000124M91	76042C04.1 1	1	Cylinder Assy	Ensemble de vérin	Gato, Conj.
2	835013M91		1	Connector Assy	Ensemble connexion	Conexión, Conj.
3		2 Ref. 2	1	Union	Union	Unión
4	835024M1	2	1	O-Ring	Joint torique	Junta de tipo O
5	3517733M1		1	Clamp	Collier de serrage	Argolla de cierre
6	L79937		1	Spacer	Entretoise	Travesa
7	6100976M92	(A)	1	Tube Assy	Tuyauterie	Conjunto de tubería
8	6101624M91	(A)	1	Elbow, 90°	Coude à 90°	Codo, 90°
9		8 (A) Ref. 8	1	Elbow	Coude	Codo
10	835024M1	8 (A)	1	O-Ring	Joint torique	Junta de tipo O
11	6101738M91	Yellow	1	Hose Assy	Ensemble de flexible	Flexible, Conj.
12	6101737M91	Red	1	Hose Assy	Ensemble de flexible	Flexible, Conj.
13	6102941M91	Yellow	1	Hose Assy	Ensemble de flexible	Flexible, Conj.
14	6102944M91	Red	1	Hose Assy	Ensemble de flexible	Flexible, Conj.
15	6101491M92		2	Support Assy	Ensemble de support	Apoyadero, Conj.
16	339761X1	M8 x 25	2	Screw	Vis	Tornillo
17	390972X1	M8	2	Washer	Rondelle	Arandela
18	394367X1	M8	2	Nut, Lock	Écrou de blocage	Tuerca de retención

A Without Hose Burst
 Sans éclatement de tuyau
 Sin rotura de tubo flexible



860 880 970 980
 TX870B TX970B

811 812 815 816 823 824 843 844 853 854 923 932

76042C03.1

6199042M3

1

Jan-06

Digger Hydraulics
Circuit Hydraulique Défonceuse
Circuito hidráulico equipo retro

Centremount
Montage de Pelle Central
Excavadora de montaje central

Dipper Cylinder
Vérin de Balancier
Gato de balancín

4.9m
 4.9m
 4.9m

C-76042-04.1-A

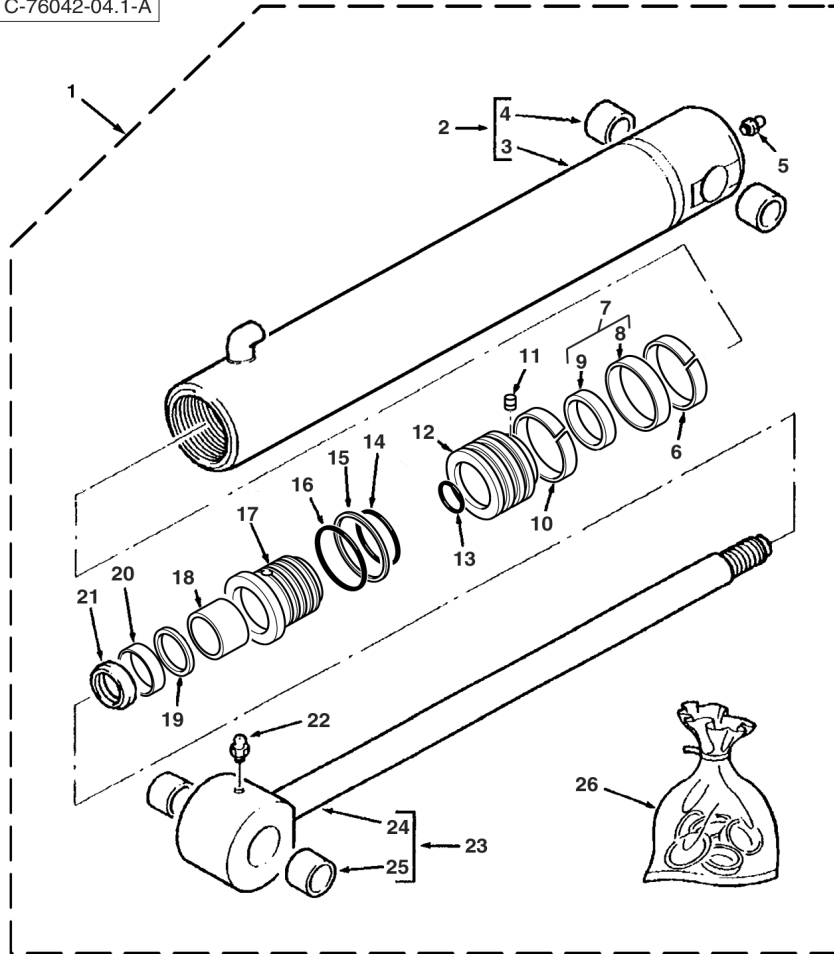

1	5000124M91	76042C03.1 1	1	Cylinder Assy	Ensemble de vérin	Gato, Conj.
2	5003982M91	1	1	Cylinder	Cylindre	Cilindro
3		2	1	Tube, Cylinder	Cylindre de vérin	Cilindro de gato
4	3484843M1	2	1	Bush	Bague	Casquillo
5	339608X1	1	1	Fitting, Grease	Graisneur	Engrasador
6	3485891M1	1 (A)	1	Ring	Anneau	Aro
7	3485247M91	1 (A)	1	Seal Assy	Ensemble de joint	Junta, Conj.
8		7	1	Seal	Joint	Junta
9		7	1	Ring	Anneau	Aro
10	3485891M1	1 (A)	1	Ring	Anneau	Aro
11	3402928M1	1	1	Screw	Vis	Tornillo
12	5003989M1	1	1	Piston	Piston	Pistón
13	3007182X1	1 (A)	1	O-Ring	Joint torique	Junta de tipo O
14	359196X1	1 (A)	1	O-Ring	Joint torique	Junta de tipo O
15	378545X1	1 (A)	1	Ring	Anneau	Aro
16	3487908M1	1 (A)	1	O-Ring	Joint torique	Junta de tipo O
17	5003988M1	1	1	Bearing	Coussinet	Cojinete
18	3623193M1	1 (A)	1	Ring	Anneau	Aro
19	3443388M1	1 (A)	1	Ring	Anneau	Aro
20	3443472M1	1 (A)	1	Seal	Joint	Junta
21	3403385M1	1 (A)	1	Ring, Wiper	Joint de racler	Junta raspador
22	339608X1	1	1	Fitting, Grease	Graisneur	Engrasador
23	5003985M91	1	1	Rod, Piston	Tige de vérin	Vástago cilindro
24		23	1	Rod, Piston	Tige de vérin	Vástago cilindro
25	3484843M1	23	1	Bush	Bague	Casquillo
26	5004401M91	(B)	1	Kit, Seal	Pochette de joints	Juego de juntas

A Included in kit marked (B)
 Inclus dans jeu marqué (B)
 Incluido en juego marcado (B)

B Contains items marked (A)
 Comprend les pièces marquées (A)
 Incluye las piezas marcadas (A)



860 880 970 980
 TX870B TX970B

811 812 815 816 823 824 843 844 853 854 923 932

76042C04.1

6199042M3

1

Jan-06

Digger Hydraulics
Circuit Hydraulique Défonceuse
Circuito hidráulico equipo retro

Centremount
Montage de Pelle Central
Excavadora de montaje central

Boom
 Flèche
 Pluma

4.9m
 4.9m
 4.9m

C-76042-05.1-A

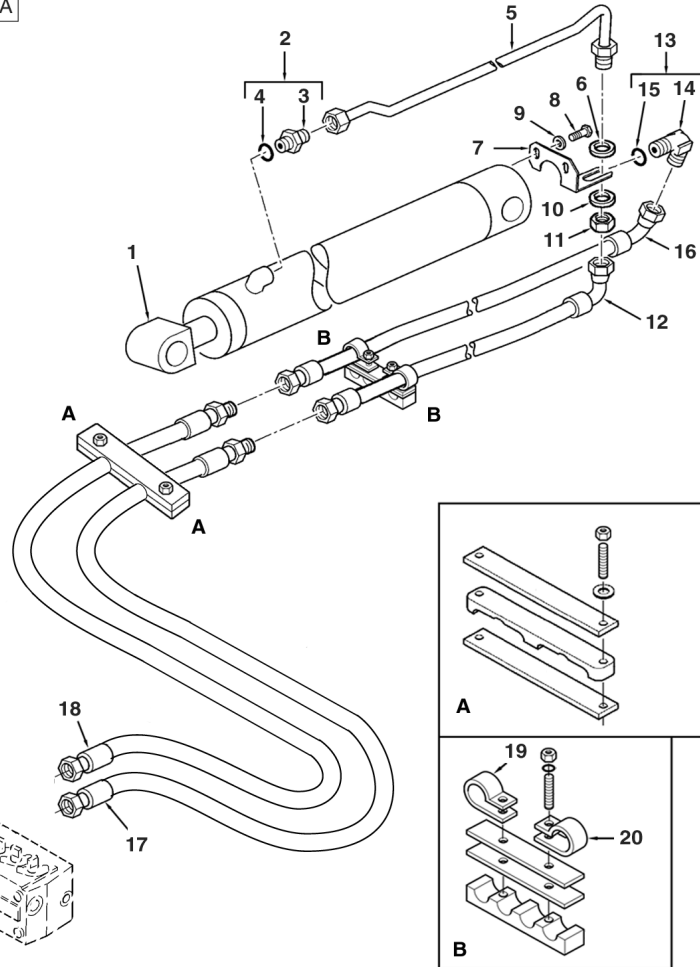

1	5000123M91	76042C06.1 1 4.9m Boom	1	Cylinder Assy	Ensemble de vérin	Gato, Conj.
2	835013M91		1	Connector Assy	Ensemble connexion	Conexión, Conj.
3		Ref. 2	1	Union	Union	Unión
4	835024M1		1	O-Ring	Joint torique	Junta de tipo O
5	6100993M91	(A)	1	Tube Assy	Tuyauterie	Conjunto de tubería
6	353763X1	(A)	1	Washer	Rondelle	Arandela
7	6100883M1	(A)	1	Bracket	Patte de fixation	Pata de fijación
8	339228X1	M8 x 12	2	Screw	Vis	Tornillo
9	339374X1	M8	2	Washer, Lock	Rondelle de blocage	Arandela de freno
10	353763X1	(A)	1	Washer	Rondelle	Arandela
11	355574X1	(A)	1	Nut	Écrou	Tuerca
12	6101735M92	(A)Orange	1	Hose Assy	Ensemble de flexible	Flexible, Conj.
13	835007M91	(A)	1	Elbow, 90°	Coude à 90°	Codo, 90°
14		Ref. 13	1	Elbow	Coude	Codo
15	835024M1		1	O-Ring	Joint torique	Junta de tipo O
16	6101736M92	Blue	1	Hose Assy	Ensemble de flexible	Flexible, Conj.
17	6102943M91	Orange	1	Hose Assy	Ensemble de flexible	Flexible, Conj.
18	6102940M91	Blue	1	Hose Assy	Ensemble de flexible	Flexible, Conj.
19	515-23270		1	Clip	Clip	Clip
20	515-23206		1	Clip	Clip	Clip

A Without Hose Burst
 Sans éclatement de tuyau
 Sin rotura de tubo flexible



860 880 970 980
 TX870B TX970B

811 812 815 816 823 824 843 844 853 854 923 932

76042C05.1

6199042M3

1

Jan-06

Digger Hydraulics
Circuit Hydraulique Défonceuse
Circuito hidráulico equipo retro

Centremount
Montage de Pelle Central
Excavadora de montaje central

Boom Cylinder
Vérin de Flèche
Gato de pluma

4.9m
 4.9m
 4.9m

C-76042-06.1-A

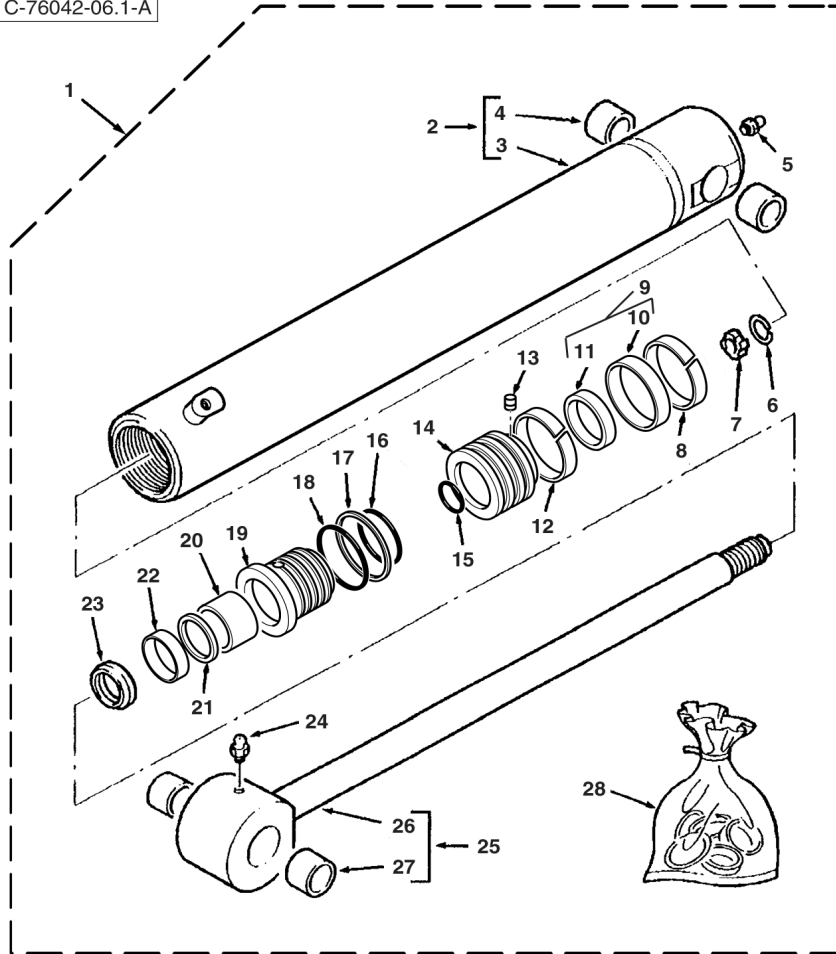

1	5000123M91	76042C05.1 1 4.9m Boom	1	Cylinder Assy	Ensemble de vérin	Gato, Conj.
2	5003993M91	1	1	Cylinder	Cylindre	Cilindro
3		2 Ref. 2	1	Tube, Cylinder	Cylindre de vérin	Cilindro de gato
4		(C)	2	Bushing	Bague	Anillo
5	339608X1	1	1	Fitting, Grease	Graisser	Engrasador
6	1609899M1	1	1	Ring, Snap	Anneau d'arrêt	Anillo de resorte
7	1609328M1	1	1	Ring	Anneau	Aro
8	3403852M1	1 (A)	1	Ring	Anneau	Aro
9	3485213M91	1 (A)	1	Seal Assy	Ensemble de joint	Junta, Conj.
10		9 Ref. 9	1	Seal	Joint	Junta
11		9 Ref. 9	1	Seal	Joint	Junta
12	3403852M1	1	1	Ring	Anneau	Aro
13	3402928M1	1	1	Screw	Vis	Tornillo
14	3484189M1	1	1	Piston	Piston	Pistón
15	3007182X1	1 (A)	1	O-Ring	Joint torique	Junta de tipo O
16	359203X1	1 (A)	1	O-Ring	Joint torique	Junta de tipo O
17	367120X1	1 (A)	1	Ring	Anneau	Aro
18	3487909M1	1 (A)	1	O-Ring	Joint torique	Junta de tipo O
19	3623202M1	1	1	Bearing	Coussinet	Cojinete
20	3623193M1	1 (A)	1	Ring	Anneau	Aro
21	3443388M1	1 (A)	1	Ring	Anneau	Aro
22	3443472M1	1 (A)	1	Seal	Joint	Junta
23	3403385M1	1 (A)	1	Ring, Wiper	Joint de racleur	Junta raspador
24	339608X1	1	1	Fitting, Grease	Graisser	Engrasador
25	3441722M91	1	1	Rod, Piston	Tige de vérin	Vástago cilindro
26		25 Ref. 25	1	Rod, Piston	Tige de vérin	Vástago cilindro
27	3484843M1	25	1	Bush	Bague	Casquillo
28	3623589M91	(B)	1	Kit, Seal	Pochette de joints	Juego de juntas

- A Included in kit marked (B)
 Inclus dans jeu marqué (B)
 Incluido en juego marcado (B)
- C Part number to be advised
 Référence pièce à demander
 Indicar número de pieza

- B Contains items marked (A)
 Comprend les pièces marquées (A)
 Incluye las piezas marcadas (A)



860 880 970 980
 TX870B TX970B

811 812 815 816 823 824 843 844 853 854 923 932

76042C06.1

6199042M3

1

Jan-06

Digger Hydraulics
Circuit Hydraulique Défonceuse
Circuito hidráulico equipo retro

Centremount
Montage de Pelle Central
Excavadora de montaje central

Swing Components
Organes de Rotation
Componentes de rotación

4.9m
 4.9m
 4.9m

C-76042-07.1-A

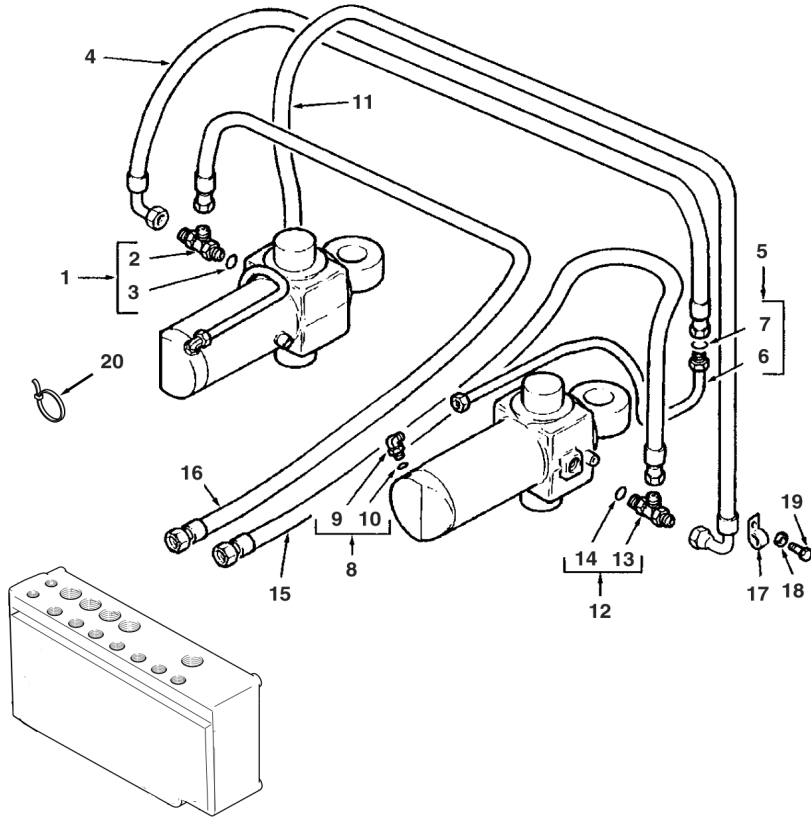

1	358728X91		1	Tee	Raccord en T	Te
2		1	▶ Ref. 1	1	Tee	Raccord en T
3	831497M1	1		1	O-Ring	Joint torique
4	6100716M91	840 mm		1	Hose Assy	Ensemble de flexible
5	6100587M91	▶		1	Tube Assy	Tuyauterie
5	6100589M91	▶		1	Tube Assy	Tuyauterie
6		5	▶ Ref. 5	1	Tube	Tube
7	394923X1	5		1	O-Ring	Joint torique
8	357197X91			2	Elbow, 90°	Coude à 90°
9		8	▶ Ref. 8	1	Elbow	Coude
10	831452M1	8		1	O-Ring	Joint torique
11	6100716M91	840 mm		1	Hose Assy	Ensemble de flexible
12	358728X91			1	Tee	Raccord en T
13		12	▶ Ref. 12	1	Tee	Raccord en T
14	831497M1	12		1	O-Ring	Joint torique
15	6100715M92	Purple 700mm		1	Hose Assy	Ensemble de flexible
16	6101866M93	Green 700mm		1	Hose Assy	Ensemble de flexible
17	3517114M2			2	Clip, Mounting	Collier de fixation
18	385361X1	M8		2	Washer	Rondelle
19	339228X1	M8 x 12		2	Screw	Vis
20	1862425M1			1	Tie, Cable	Attache câble



860 880 970 980
 TX870B TX970B

811 812 815 816 823 824 843 844 853 854 923 932

76042C07.1

6199042M3

1

Jan-06

Digger Hydraulics
Circuit Hydraulique Défonceuse
Circuito hidráulico equipo retro

Centremount
Montage de Pelle Central
Excavadora de montaje central

Bucket
 Godet
 Cuchara

4.9m
 4.9m
 4.9m

C-76043-01.1-A

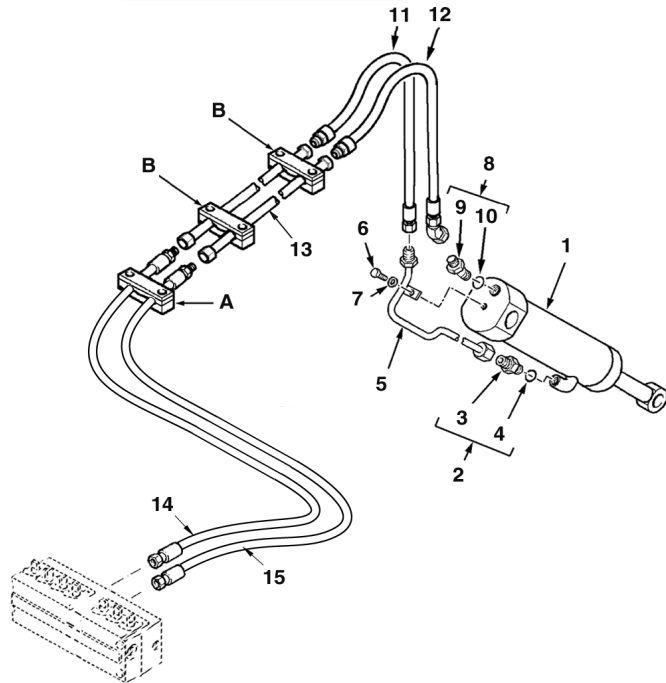
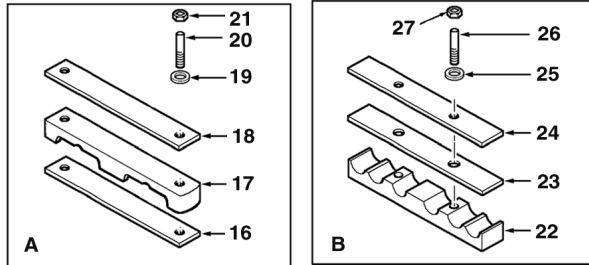

1	5000126M91	76043C02.1 1	1	Cylinder Assy	Ensemble de vérin	Gato, Conj.
2	835013M91		1	Connector Assy	Ensemble connexion	Conexión, Conj.
3		2 Ref. 2	1	Union	Union	Unión
4	835024M1	2	1	O-Ring	Joint torique	Junta de tipo O
5	6101540M91		1	Tube Assy	Tuyauterie	Conjunto de tubería
6	339123X1	M8 x 20	1	Bolt	Boulon	Perno
7	385361X1	M8	1	Washer	Rondelle	Arandela
8	835010M91		1	Elbow, 45°	Coude à 45°	Codo, 45°
9		8 Ref. 8	1	Elbow	Coude	Codo
10	835024M1	8	1	O-Ring	Joint torique	Junta de tipo O
11		(A)Brown	1	Hose Assy	Ensemble de flexible	Flexible, Conj.
12		(A)White	1	Hose Assy	Ensemble de flexible	Flexible, Conj.
13	6101431M91		2	Tube Assy	Tuyauterie	Conjunto de tubería
14	6102945M91	Brown	1	Hose Assy	Ensemble de flexible	Flexible, Conj.
15	6102942M91	White	1	Hose Assy	Ensemble de flexible	Flexible, Conj.
16	6102128M1		1	Pad	Plaque antidérapante	Cinta antideslizante
17	6102122M1		1	Bracket, Clamp	Bride de fixation	Brida de fijación
18	6102130M1		1	Plate	Plaque	Placa
19	390972X1	M8	2	Washer	Rondelle	Arandela
20	3516075M1	M8 x 65	2	Stud	Goujon	Espárrago
21	394367X1	M8	2	Nut, Lock	Écrou de blocage	Tuerca de retención
22	6102126M1		2	Bracket, Clamp	Bride de fixation	Brida de fijación
23	6102145M1		2	Pad	Plaque antidérapante	Cinta antideslizante
24	6102124M1		2	Plate	Plaque	Placa
25	390972X1	M8	4	Washer	Rondelle	Arandela
26	6108049M1		4	Stud	Goujon	Espárrago
27	394367X1	M8	4	Nut, Lock	Écrou de blocage	Tuerca de retención

A See extendahoe hydraulics section
 Voir la section circuit hydraulique extendahoe
 Ver la sección de la circuito hidráulico extendahoe



860 880 970 980
 TX870B TX970B

811 812 815 816 823 824 843 844 853 854 923 932

76043C01.1

6199042M3

1

Jan-06

Digger Hydraulics
Circuit Hydraulique Défonceuse
Circuito hidráulico equipo retro

Centremount
Montage de Pelle Central
Excavadora de montaje central

Bucket Cylinder
Vérin de Godet
Gato de cuchara

4.9m
 4.9m
 4.9m

C-76043-02.1-A

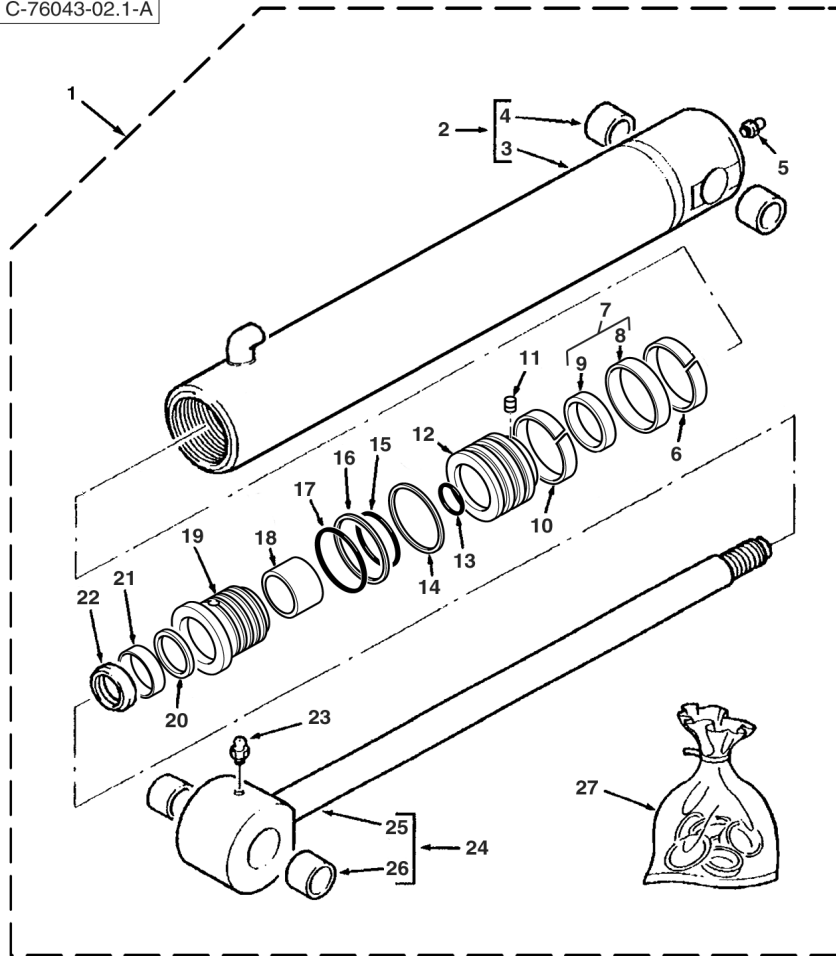

1	5000126M91		76043C01.1 1	1	Cylinder Assy	Ensemble de vérin	Gato, Conj.
2	5004008M91	1		1	Cylinder	Cylindre	Cilindro
3		3	Ref. 2	1	Tube, Cylinder	Cylindre de vérin	Cilindro de gato
4		3 (C)		1	Bushing	Bague	Anillo
5	339608X1	1		1	Fitting, Grease	Graisneur	Engrasador
6	3485892M1	1 (A)		1	Ring, Sealing	Bague d'étanchéité	Anillo, Estanqueidad
7	3485245M91	1 (A)		1	Seal Assy	Ensemble de joint	Junta, Conj.
8		7	Ref. 7	1	Seal	Joint	Junta
9		7	Ref. 7	1	Ring	Anneau	Aro
10	3485892M1	1 (A)		1	Ring, Sealing	Bague d'étanchéité	Anillo, Estanqueidad
11	3402928M1	1		1	Screw	Vis	Tornillo
12	3623372M1	1		1	Piston	Piston	Pistón
13	359186X1	1 (A)		1	O-Ring	Joint torique	Junta de tipo O
14	3623061M1	1		1	Ring, Piston	Segment de piston	Segmento de pistón
15	359193X1	1 (A)		1	O-Ring	Joint torique	Junta de tipo O
16	1606735M1	1 (A)		1	Ring, Backup	Contre-joint	ContraJunta
17	3487207M1	1 (A)		1	O-Ring	Joint torique	Junta de tipo O
18	3484615M1	1 (A)		1	Ring	Anneau	Aro
19	3623371M1	1		1	Bearing	Coussinet	Cojinete
20	3484055M1	1 (A)		1	Ring	Anneau	Aro
21	3485185M1	1 (A)		1	Seal	Joint	Junta
22	3487015M1	1 (A)		1	Ring	Anneau	Aro
23	339608X1	1		1	Fitting, Grease	Graisneur	Engrasador
24	5004012M91	1		1	Rod, Piston	Tige de vérin	Vástago cilindro
25		24	Ref. 24	1	Rod, Piston	Tige de vérin	Vástago cilindro
26		24 (C)		1	Bushing	Bague	Anillo
27	3623373M91		(B)	1	Kit, Seal	Pochette de joints	Juego de juntas

A Contains items marked (A)
 Comprend les pièces marquées (A)
 Incluye las piezas marcadas (A)
 C Part number to be advised
 Référence pièce à demander
 Indicar número de pieza

B Included in kit marked (B)
 Inclus dans jeu marqué (B)
 Incluido en juego marcado (B)



860 880 970 980
 TX870B TX970B

811 812 815 816 823 824 843 844 853 854 923 932

76043C02.1

6199042M3

1

Jan-06

Digger Hydraulics
Circuit Hydraulique Défonceuse
Circuito hidráulico equipo retro

Centremount
Montage de Pelle Central
Excavadora de montaje central

Telescopic Dipper
Balancier Téléscopique
Balancín telescópico

4.9m
 4.9m
 4.9m

C-76043-03.1-A

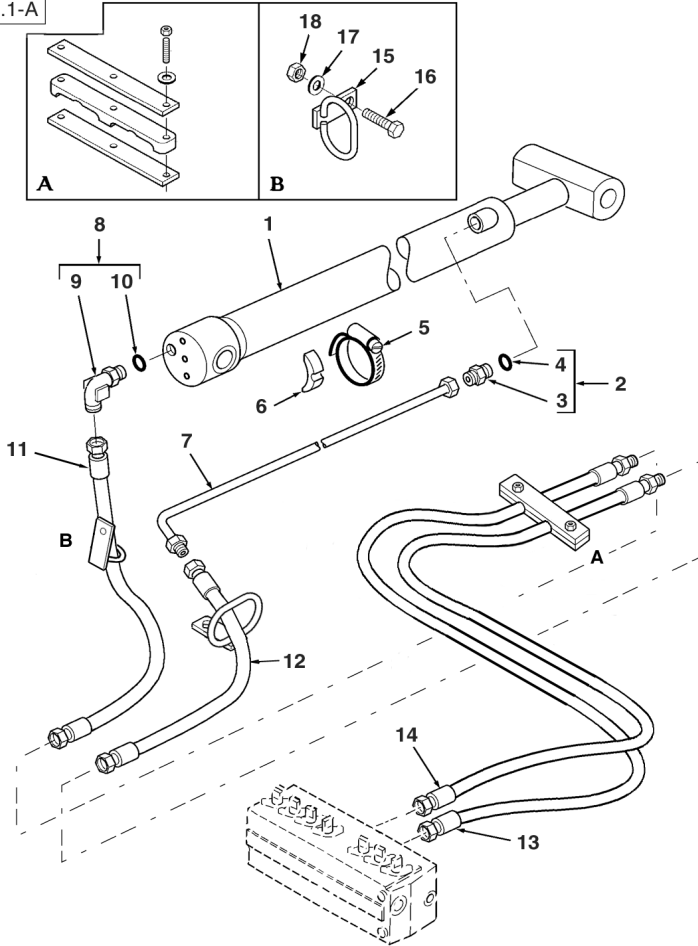

1	5000124M91	76043C04.1 1	1	Cylinder Assy	Ensemble de vérin	Gato, Conj.
2	835013M91		1	Connector Assy	Ensemble connexion	Conexión, Conj.
3		2 Ref. 2	1	Union	Union	Unión
4	835024M1	2	1	O-Ring	Joint torique	Junta de tipo O
5	3517733M1		1	Clamp	Collier de serrage	Argolla de cierre
6	L79937		1	Spacer	Entretoise	Travesa
7	6100976M92	(A)	1	Tube Assy	Tuyauterie	Conjunto de tubería
8	6101624M91	(A)	1	Elbow, 90°	Coude à 90°	Codo, 90°
9		8 (A) Ref. 8	1	Elbow	Coude	Codo
10	835024M1	8 (A)	1	O-Ring	Joint torique	Junta de tipo O
11	6101738M91	Yellow	1	Hose Assy	Ensemble de flexible	Flexible, Conj.
12	6101737M91	Red	1	Hose Assy	Ensemble de flexible	Flexible, Conj.
13	6102941M91	Yellow	1	Hose Assy	Ensemble de flexible	Flexible, Conj.
14	6102944M91	Red	1	Hose Assy	Ensemble de flexible	Flexible, Conj.
15	6101491M92		2	Support Assy	Ensemble de support	Apoyadero, Conj.
16	339761X1	M8 x 25	2	Screw	Vis	Tornillo
17	390972X1	M8	2	Washer	Rondelle	Arandela
18	394367X1	M8	2	Nut, Lock	Écrou de blocage	Tuerca de retención

A Without Hose Burst
 Sans éclatement de tuyau
 Sin rotura de tubo flexible



860 880 970 980
 TX870B TX970B

811 812 815 816 823 824 843 844 853 854 923 932

76043C03.1

6199042M3

1

Jan-06

Digger Hydraulics
Circuit Hydraulique Défonceuse
Circuito hidráulico equipo retro

Centremount
Montage de Pelle Central
Excavadora de montaje central

Dipper Cylinder
Vérin de Balancier
Gato de balancín

4.9m
 4.9m
 4.9m

C-76043-04.1-A

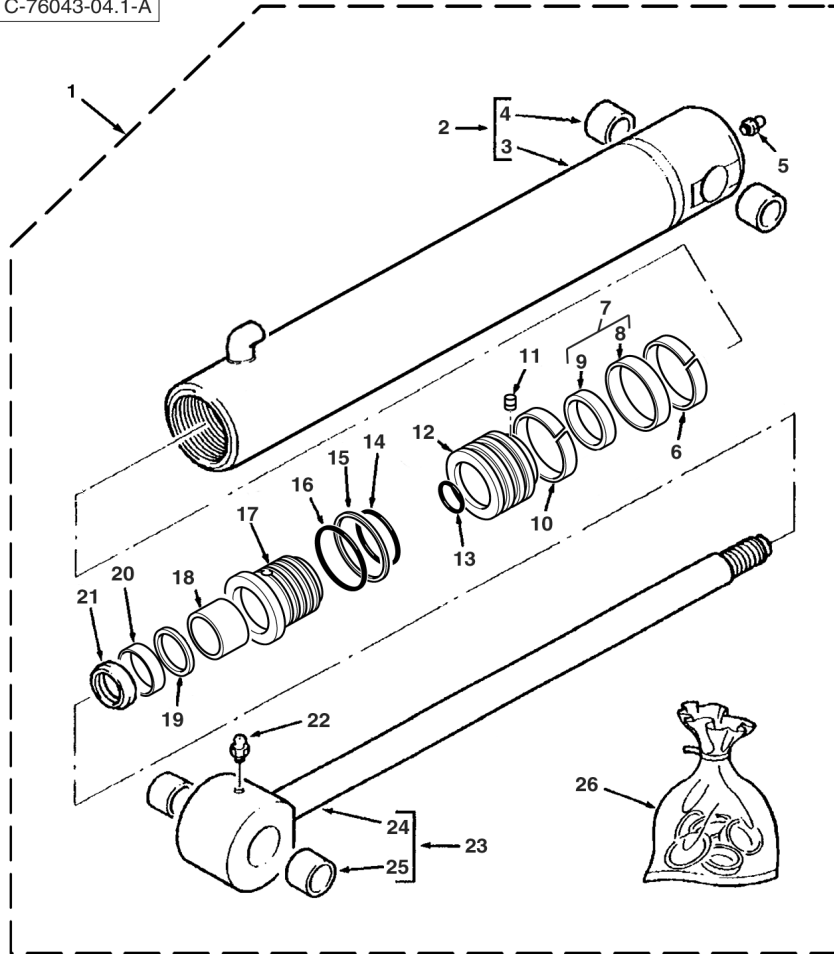

1	5000124M91	76043C03.1 1	1	Cylinder Assy	Ensemble de vérin	Gato, Conj.
2	5003982M91	1	1	Cylinder	Cylindre	Cilindro
3		2	1	Tube, Cylinder	Cylindre de vérin	Cilindro de gato
4	3484843M1	2	1	Bush	Bague	Casquillo
5	339608X1	1	1	Fitting, Grease	Graisneur	Engrasador
6	3485891M1	1 (A)	1	Ring	Anneau	Aro
7	3485247M91	1 (A)	1	Seal Assy	Ensemble de joint	Junta, Conj.
8		7	1	Seal	Joint	Junta
9		7	1	Ring	Anneau	Aro
10	3485891M1	1 (A)	1	Ring	Anneau	Aro
11	3402928M1	1	1	Screw	Vis	Tornillo
12	5003989M1	1	1	Piston	Piston	Pistón
13	3007182X1	1 (A)	1	O-Ring	Joint torique	Junta de tipo O
14	359196X1	1 (A)	1	O-Ring	Joint torique	Junta de tipo O
15	378545X1	1 (A)	1	Ring	Anneau	Aro
16	3487908M1	1 (A)	1	O-Ring	Joint torique	Junta de tipo O
17	5003988M1	1	1	Bearing	Coussinet	Cojinete
18	3623193M1	1 (A)	1	Ring	Anneau	Aro
19	3443388M1	1 (A)	1	Ring	Anneau	Aro
20	3443472M1	1 (A)	1	Seal	Joint	Junta
21	3403385M1	1 (A)	1	Ring, Wiper	Joint de racler	Junta raspador
22	339608X1	1	1	Fitting, Grease	Graisneur	Engrasador
23	5003985M91	1	1	Rod, Piston	Tige de vérin	Vástago cilindro
24		23	1	Rod, Piston	Tige de vérin	Vástago cilindro
25	3484843M1	23	1	Bush	Bague	Casquillo
26	5004401M91	(B)	1	Kit, Seal	Pochette de joints	Juego de juntas

A Included in kit marked (B)
 Inclus dans jeu marqué (B)
 Incluido en juego marcado (B)

B Contains items marked (A)
 Comprend les pièces marquées (A)
 Incluye las piezas marcadas (A)



860 880 970 980
 TX870B TX970B

811 812 815 816 823 824 843 844 853 854 923 932

76043C04.1

6199042M3

1

Jan-06

Digger Hydraulics
Circuit Hydraulique Défonceuse
Circuito hidráulico equipo retro

Centremount
Montage de Pelle Central
Excavadora de montaje central

Boom
 Flèche
 Pluma

4.9m
 4.9m
 4.9m

C-76043-05.1-A

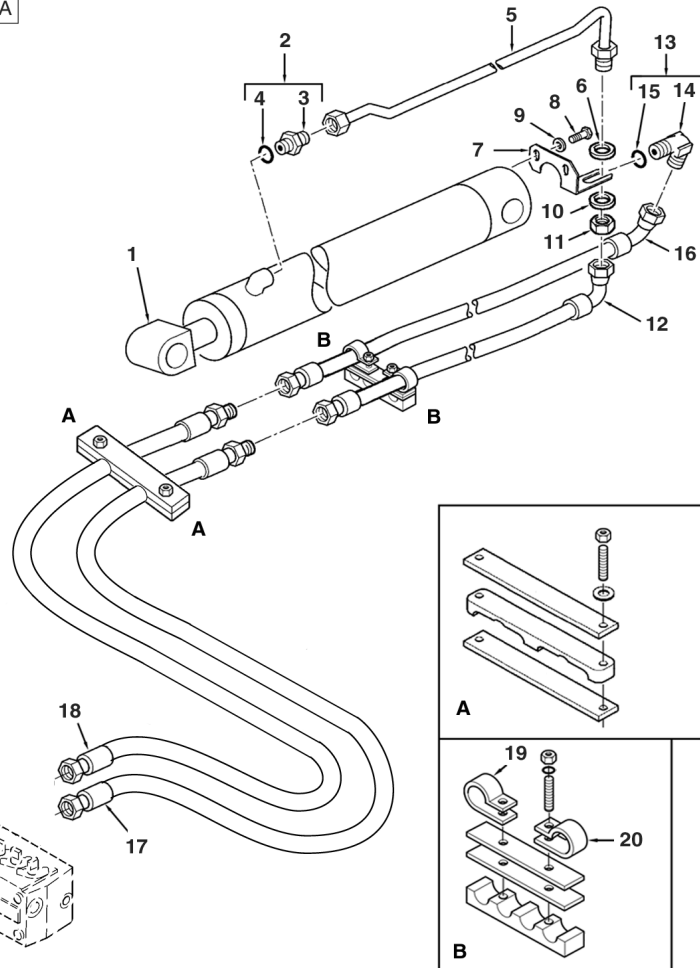

1	5000123M91	76043C06.1 1 4.9m Boom	1	Cylinder Assy	Ensemble de vérin	Gato, Conj.
2	835013M91		1	Connector Assy	Ensemble connexion	Conexión, Conj.
3		Ref. 2	1	Union	Union	Unión
4	835024M1		1	O-Ring	Joint torique	Junta de tipo O
5	6100993M91	(A)	1	Tube Assy	Tuyauterie	Conjunto de tubería
6	353763X1	(A)	1	Washer	Rondelle	Arandela
7	6100883M1	(A)	1	Bracket	Patte de fixation	Pata de fijación
8	339228X1	M8 x 12	2	Screw	Vis	Tornillo
9	339374X1	M8	2	Washer, Lock	Rondelle de blocage	Arandela de freno
10	353763X1	(A)	1	Washer	Rondelle	Arandela
11	355574X1	(A)	1	Nut	Écrou	Tuerca
12	6101735M92	(A)Orange	1	Hose Assy	Ensemble de flexible	Flexible, Conj.
13	835007M91	(A)	1	Elbow, 90°	Coude à 90°	Codo, 90°
14		Ref. 13	1	Elbow	Coude	Codo
15	835024M1		1	O-Ring	Joint torique	Junta de tipo O
16	6101736M92	Blue	1	Hose Assy	Ensemble de flexible	Flexible, Conj.
17	6102943M91	Orange	1	Hose Assy	Ensemble de flexible	Flexible, Conj.
18	6102940M91	Blue	1	Hose Assy	Ensemble de flexible	Flexible, Conj.
19	515-23270		1	Clip	Clip	Clip
20	515-23206		1	Clip	Clip	Clip

A Without Hose Burst
 Sans éclatement de tuyau
 Sin rotura de tubo flexible



860 880 970 980
 TX870B TX970B

811 812 815 816 823 824 843 844 853 854 923 932

76043C05.1

6199042M3

1

Jan-06

Digger Hydraulics
Circuit Hydraulique Défonceuse
Circuito hidráulico equipo retro

Centremount
Montage de Pelle Central
Excavadora de montaje central

Boom Cylinder
Vérin de Flèche
Gato de pluma

4.9m
 4.9m
 4.9m

C-76043-06.1-A

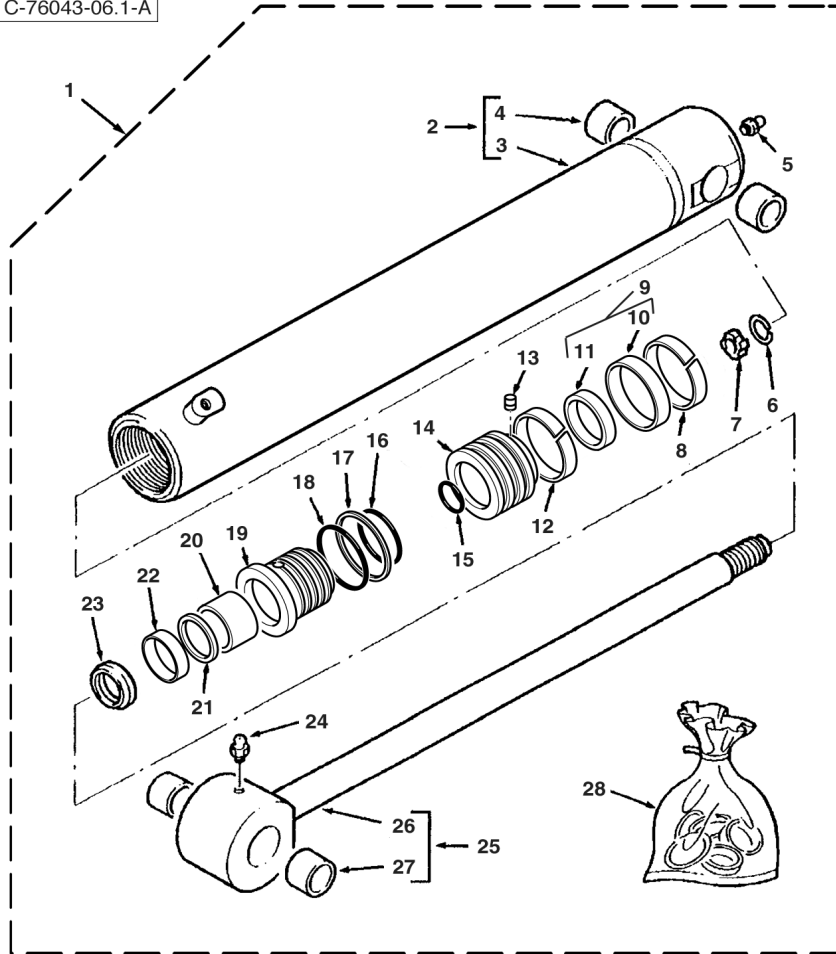

1	5000123M91	76043C05.1 1 4.9m Boom	1	Cylinder Assy	Ensemble de vérin	Gato, Conj.
2	5003993M91	1	1	Cylinder	Cylindre	Cilindro
3		2 Ref. 2	1	Tube, Cylinder	Cylindre de vérin	Cilindro de gato
4		(C)	2	Bushing	Bague	Anillo
5	339608X1	1	1	Fitting, Grease	Graisser	Engrasador
6	1609899M1	1	1	Ring, Snap	Anneau d'arrêt	Anillo de resorte
7	1609328M1	1	1	Ring	Anneau	Aro
8	3403852M1	1 (A)	1	Ring	Anneau	Aro
9	3485213M91	1 (A)	1	Seal Assy	Ensemble de joint	Junta, Conj.
10		9 Ref. 9	1	Seal	Joint	Junta
11		9 Ref. 9	1	Seal	Joint	Junta
12	3403852M1	1	1	Ring	Anneau	Aro
13	3402928M1	1	1	Screw	Vis	Tornillo
14	3484189M1	1	1	Piston	Piston	Pistón
15	3007182X1	1 (A)	1	O-Ring	Joint torique	Junta de tipo O
16	359203X1	1 (A)	1	O-Ring	Joint torique	Junta de tipo O
17	367120X1	1 (A)	1	Ring	Anneau	Aro
18	3487909M1	1 (A)	1	O-Ring	Joint torique	Junta de tipo O
19	3623202M1	1	1	Bearing	Coussinet	Cojinete
20	3623193M1	1 (A)	1	Ring	Anneau	Aro
21	3443388M1	1 (A)	1	Ring	Anneau	Aro
22	3443472M1	1 (A)	1	Seal	Joint	Junta
23	3403385M1	1 (A)	1	Ring, Wiper	Joint de racleur	Junta raspador
24	339608X1	1	1	Fitting, Grease	Graisser	Engrasador
25	3441722M91	1	1	Rod, Piston	Tige de vérin	Vástago cilindro
26		25 Ref. 25	1	Rod, Piston	Tige de vérin	Vástago cilindro
27	3484843M1	25	1	Bush	Bague	Casquillo
28	3623589M91	(B)	1	Kit, Seal	Pochette de joints	Juego de juntas

- A Included in kit marked (B)
 Inclus dans jeu marqué (B)
 Incluido en juego marcado (B)
- C Part number to be advised
 Référence pièce à demander
 Indicar número de pieza

- B Contains items marked (A)
 Comprend les pièces marquées (A)
 Incluye las piezas marcadas (A)



860 880 970 980
 TX870B TX970B

811 812 815 816 823 824 843 844 853 854 923 932

76043C06.1

6199042M3

1

Jan-06

Digger Hydraulics
Circuit Hydraulique Défonceuse
Circuito hidráulico equipo retro

Centremount
Montage de Pelle Central
Excavadora de montaje central

Swing Components
Organes de Rotation
Componentes de rotación

4.9m
 4.9m
 4.9m

C-76043-07.1-A

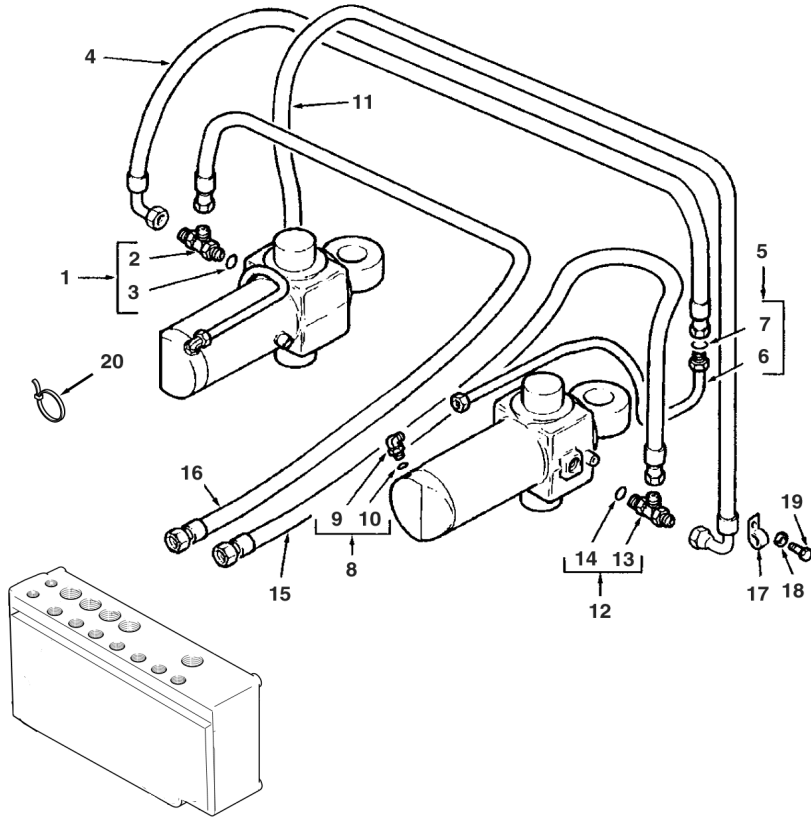

1	358728X91		1	Tee	Raccord en T	Te
2		1	▶ Ref. 1	1	Tee	Raccord en T
3	831497M1	1		1	O-Ring	Joint torique
4	6100716M91	840 mm		1	Hose Assy	Ensemble de flexible
5	6100587M91	▶		1	Tube Assy	Tuyauterie
5	6100589M91	▶		1	Tube Assy	Tuyauterie
6		5	▶ Ref. 5	1	Tube	Tube
7	394923X1	5		1	O-Ring	Joint torique
8	357197X91			2	Elbow, 90°	Coude à 90°
9		8	▶ Ref. 8	1	Elbow	Coude
10	831452M1	8		1	O-Ring	Joint torique
11	6100716M91	840 mm		1	Hose Assy	Ensemble de flexible
12	358728X91			1	Tee	Raccord en T
13		12	▶ Ref. 12	1	Tee	Raccord en T
14	831497M1	12		1	O-Ring	Joint torique
15	6100715M92	Purple 700mm		1	Hose Assy	Ensemble de flexible
16	6101866M93	Green 700mm		1	Hose Assy	Ensemble de flexible
17	3517114M2			2	Clip, Mounting	Collier de fixation
18	385361X1	M8		2	Washer	Rondelle
19	339228X1	M8 x 12		2	Screw	Vis
20	1862425M1			1	Tie, Cable	Attache câble



860 880 970 980
 TX870B TX970B

811 812 815 816 823 824 843 844 853 854 923 932

76043C07.1

6199042M3

1

Jan-06

Digger Hydraulics
Circuit Hydraulique Défonceuse
Circuito hidráulico equipo retro

Centremount
Montage de Pelle Central
Excavadora de montaje central

Bucket
 Godet
 Cuchara

Std. Spec.
 Std. Spec.
 Std. Spec.

C-76044-01.1-A

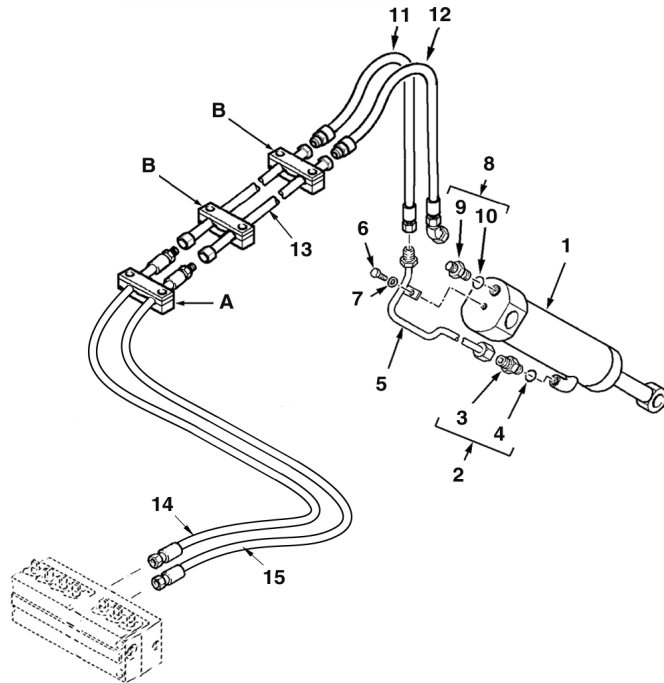
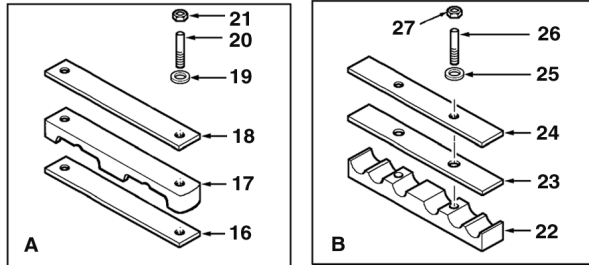

1	5000126M91	76044C02.1 1	1	Cylinder Assy	Ensemble de vérin	Gato, Conj.
2	835013M91		1	Connector Assy	Ensemble connexion	Conexión, Conj.
3		2 Ref. 2	1	Union	Union	Unión
4	835024M1	2	1	O-Ring	Joint torique	Junta de tipo O
5	6101540M91		1	Tube Assy	Tuyauterie	Conjunto de tubería
6	339123X1	M8 x 20	1	Bolt	Boulon	Perno
7	385361X1	M8	1	Washer	Rondelle	Arandela
8	835013M91		1	Connector Assy	Ensemble connexion	Conexión, Conj.
9		8 Ref. 8	1	Union	Union	Unión
10	835024M1	8	1	O-Ring	Joint torique	Junta de tipo O
11	6102309M91	Brown	1	Hose Assy	Ensemble de flexible	Flexible, Conj.
12	6107024M91	White	1	Hose Assy	Ensemble de flexible	Flexible, Conj.
13	6101771M91		2	Tube Assy	Tuyauterie	Conjunto de tubería
14	6102945M91	Brown	1	Hose Assy	Ensemble de flexible	Flexible, Conj.
15	6102942M91	White	1	Hose Assy	Ensemble de flexible	Flexible, Conj.
16	6102128M1		1	Pad	Plaque antidérapante	Cinta antideslizante
17	6102122M1		1	Bracket, Clamp	Bride de fixation	Brida de fijación
18	6102130M1		1	Plate	Plaque	Placa
19	390972X1	M8	2	Washer	Rondelle	Arandela
20	3516075M1	M8 x 65	2	Stud	Goujon	Espárrago
21	394367X1	M8	2	Nut, Lock	Écrou de blocage	Tuerca de retención
22	6102126M1		2	Bracket, Clamp	Bride de fixation	Brida de fijación
23	6102145M1		2	Pad	Plaque antidérapante	Cinta antideslizante
24	6102124M1		2	Plate	Plaque	Placa
25	390972X1	M8	4	Washer	Rondelle	Arandela
26	6108049M1		4	Stud	Goujon	Espárrago
27	394367X1	M8	4	Nut, Lock	Écrou de blocage	Tuerca de retención



820
 TX760B

801 802 803 804 831 832

76044C01.1

6199042M3

1

Jan-06

Digger Hydraulics
Circuit Hydraulique Défonceuse
Circuito hidráulico equipo retro

Centremount
Montage de Pelle Central
Excavadora de montaje central

Bucket Cylinder
Vérin de Godet
Gato de cuchara

Std. Spec.
 Std. Spec.
 Std. Spec.

C-76044-02.1-A

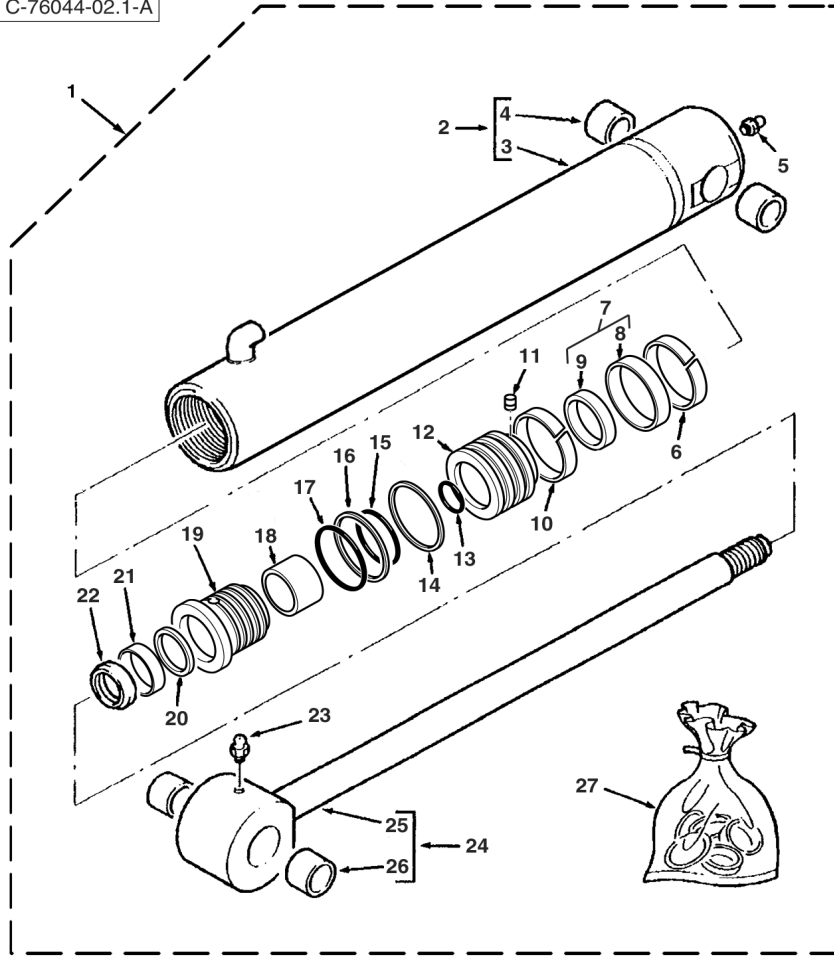

1	5000126M91		76044C01.1 1	1	Cylinder Assy	Ensemble de vérin	Gato, Conj.
2	5004008M91	1		1	Cylinder	Cylindre	Cilindro
3		3	Ref. 2	1	Tube, Cylinder	Cylindre de vérin	Cilindro de gato
4		3 (C)		1	Bushing	Bague	Anillo
5	339608X1	1		1	Fitting, Grease	Graisser	Engrasador
6	3485892M1	1 (A)		1	Ring, Sealing	Bague d'étanchéité	Anillo, Estanqueidad
7	3485245M91	1 (A)		1	Seal Assy	Ensemble de joint	Junta, Conj.
8		7	Ref. 7	1	Seal	Joint	Junta
9		7	Ref. 7	1	Ring	Anneau	Aro
10	3485892M1	1 (A)		1	Ring, Sealing	Bague d'étanchéité	Anillo, Estanqueidad
11	3402928M1	1		1	Screw	Vis	Tornillo
12	3623372M1	1		1	Piston	Piston	Pistón
13	359186X1	1 (A)		1	O-Ring	Joint torique	Junta de tipo O
14	3623061M1	1		1	Ring, Piston	Segment de piston	Segmento de pistón
15	359193X1	1 (A)		1	O-Ring	Joint torique	Junta de tipo O
16	1606735M1	1 (A)		1	Ring, Backup	Contre-joint	ContraJunta
17	3487207M1	1 (A)		1	O-Ring	Joint torique	Junta de tipo O
18	3484615M1	1 (A)		1	Ring	Anneau	Aro
19	3623371M1	1		1	Bearing	Coussinet	Cojinete
20	3484055M1	1 (A)		1	Ring	Anneau	Aro
21	3485185M1	1 (A)		1	Seal	Joint	Junta
22	3487015M1	1 (A)		1	Ring	Anneau	Aro
23	339608X1	1		1	Fitting, Grease	Graisser	Engrasador
24	5004012M91	1		1	Rod, Piston	Tige de vérin	Vástago cilindro
25		24	Ref. 24	1	Rod, Piston	Tige de vérin	Vástago cilindro
26		24 (C)		1	Bushing	Bague	Anillo
27	3623373M91		(B)	1	Kit, Seal	Pochette de joints	Juego de juntas

A Contains items marked (A)
 Comprend les pièces marquées (A)
 Incluye las piezas marcadas (A)
 C Part number to be advised
 Référence pièce à demander
 Indicar número de pieza

B Included in kit marked (B)
 Inclus dans jeu marqué (B)
 Incluido en juego marcado (B)



820
 TX760B

801 802 803 804 831 832

76044C02.1

6199042M3

1

Jan-06

Digger Hydraulics
Circuit Hydraulique Défonceuse
Circuito hidráulico equipo retro

Centremount
Montage de Pelle Central
Excavadora de montaje central

Standard Dipper
Balancier Standard
Balancín estándar

Std. Spec.
 Std. Spec.
 Std. Spec.

C-76044-03.1-A

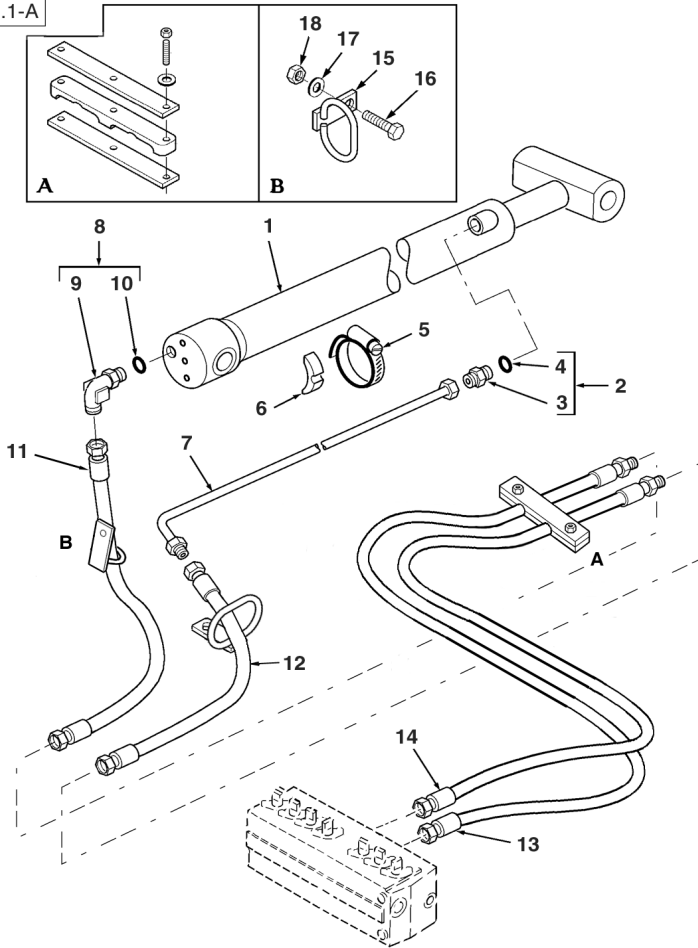

1	5000124M91	76044C04.1 1	1	Cylinder Assy	Ensemble de vérin	Gato, Conj.
2	835013M91		1	Connector Assy	Ensemble connexion	Conexión, Conj.
3		2 Ref. 2	1	Union	Union	Unión
4	835024M1	2	1	O-Ring	Joint torique	Junta de tipo O
5	3517733M1		1	Clamp	Collier de serrage	Argolla de cierre
6	L79937		1	Spacer	Entretoise	Travesa
7		(A,B)	1	Tube Assy	Tuyauterie	Conjunto de tubería
8		(A,B)	1	Elbow	Coude	Codo
9		8 (A,B) Ref. 8	1	Elbow	Coude	Codo
10		8 (A,B)	1	O-Ring	Joint torique	Junta de tipo O
11	6101738M91	Yellow	1	Hose Assy	Ensemble de flexible	Flexible, Conj.
12	6101737M91	Red	1	Hose Assy	Ensemble de flexible	Flexible, Conj.
13	6102941M91	Yellow	1	Hose Assy	Ensemble de flexible	Flexible, Conj.
14	6102944M91	Red	1	Hose Assy	Ensemble de flexible	Flexible, Conj.
15	6101491M92		2	Support Assy	Ensemble de support	Apoyadero, Conj.
16	339761X1	M8 x 25	2	Screw	Vis	Tornillo
17	390972X1	M8	2	Washer	Rondelle	Arandela
18	394367X1	M8	2	Nut, Lock	Écrou de blocage	Tuerca de retención

A Without Hose Burst
 Sans éclatement de tuyau
 Sin rotura de tubo flexible

B See hose burst section
 Voir la section éclatement de tuyau
 Ver la sección de rotura de tubo flexible



820
 TX760B

801 802 803 804 831 832

76044C03.1

6199042M3

1

Jan-06

Digger Hydraulics
Circuit Hydraulique Défonceuse
Circuito hidráulico equipo retro

Centremount
Montage de Pelle Central
Excavadora de montaje central

Dipper Cylinder
Vérin de Balancier
Gato de balancín

Std. Spec.
 Std. Spec.
 Std. Spec.

C-76044-04.1-A

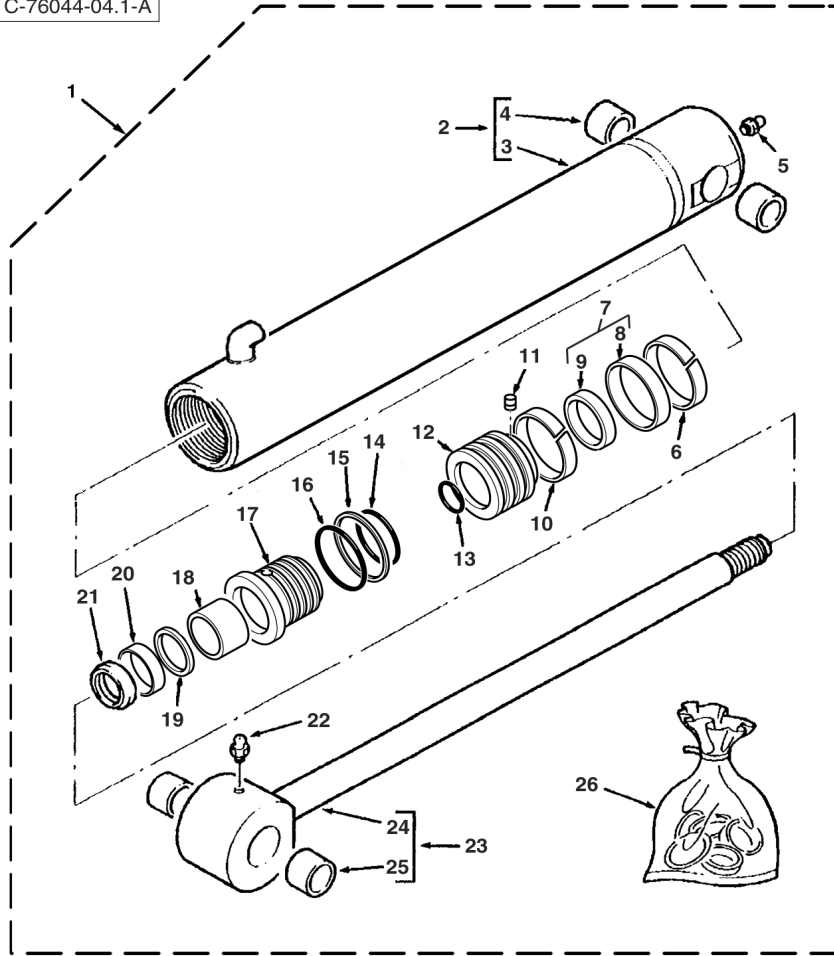

1	5000124M91		76044C03.1 1	1	Cylinder Assy	Ensemble de vérin	Gato, Conj.
2	5003982M91	1		1	Cylinder	Cylindre	Cilindro
3		2	Ref. 2	1	Tube, Cylinder	Cylindre de vérin	Cilindro de gato
4	3484843M1	2		1	Bush	Bague	Casquillo
5	339608X1	1		1	Fitting, Grease	Graisneur	Engrasador
6	3485891M1	1 (A)		1	Ring	Anneau	Aro
7	3485247M91	1 (A)		1	Seal Assy	Ensemble de joint	Junta, Conj.
8		7	Ref. 7	1	Seal	Joint	Junta
9		7	Ref. 7	1	Ring	Anneau	Aro
10	3485891M1	1 (A)		1	Ring	Anneau	Aro
11	3402928M1	1		1	Screw	Vis	Tornillo
12	5003989M1	1		1	Piston	Piston	Pistón
13	3007182X1	1 (A)		1	O-Ring	Joint torique	Junta de tipo O
14	359196X1	1 (A)		1	O-Ring	Joint torique	Junta de tipo O
15	378545X1	1 (A)		1	Ring	Anneau	Aro
16	3487908M1	1 (A)		1	O-Ring	Joint torique	Junta de tipo O
17	5003988M1	1		1	Bearing	Coussinet	Cojinete
18	3623193M1	1 (A)		1	Ring	Anneau	Aro
19	3443388M1	1 (A)		1	Ring	Anneau	Aro
20	3443472M1	1 (A)		1	Seal	Joint	Junta
21	3403385M1	1 (A)		1	Ring, Wiper	Joint de racler	Junta raspador
22	339608X1	1		1	Fitting, Grease	Graisneur	Engrasador
23	5003985M91	1		1	Rod, Piston	Tige de vérin	Vástago cilindro
24		23	Ref. 23	1	Rod, Piston	Tige de vérin	Vástago cilindro
25	3484843M1	23		1	Bush	Bague	Casquillo
26	5004401M91		(B)	1	Kit, Seal	Pochette de joints	Juego de juntas

A Included in kit marked (B)
 Inclus dans jeu marqué (B)
 Incluido en juego marcado (B)

B Contains items marked (A)
 Comprend les pièces marquées (A)
 Incluye las piezas marcadas (A)



820
 TX760B

801 802 803 804 831 832

76044C04.1

6199042M3

1

Jan-06

Digger Hydraulics
Circuit Hydraulique Défonceuse
Circuito hidráulico equipo retro

Centremount
Montage de Pelle Central
Excavadora de montaje central

Boom 4.5m
 Flèche 4.5m
 Pluma 4.5m

Std. Spec.
 Std. Spec.
 Std. Spec.

C-76044-05.1-A

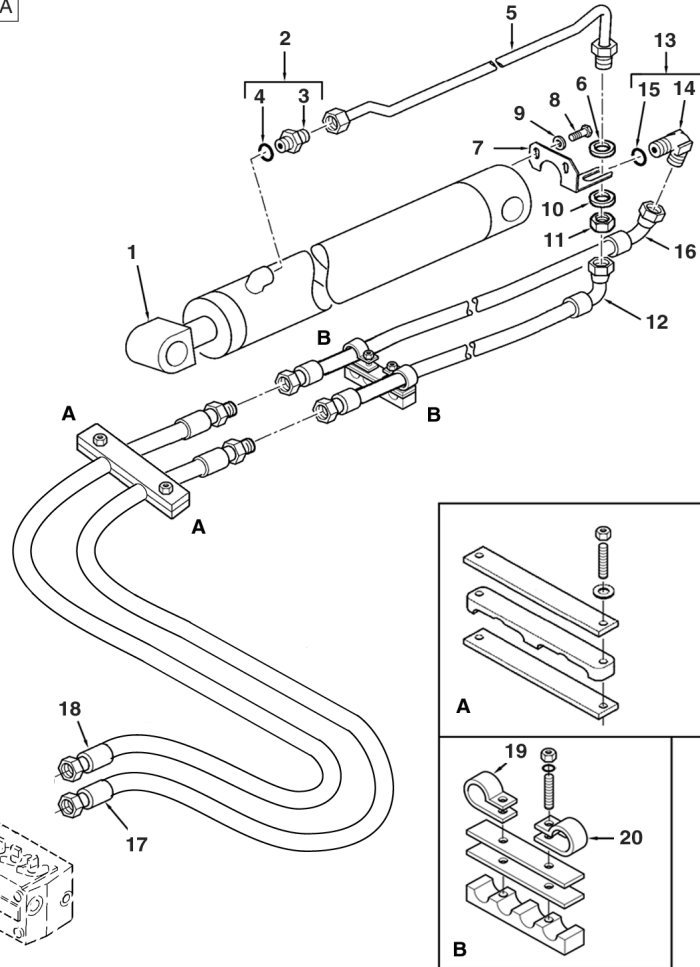

1	5000121M91	76044C06.1 1	1	Cylinder Assy	Ensemble de vérin	Gato, Conj.
2	835013M91		1	Connector Assy	Ensemble connexion	Conexión, Conj.
3		2 Ref. 2	1	Union	Union	Unión
4	835024M1	2	1	O-Ring	Joint torique	Junta de tipo O
5		(A,B)	1	Tube Assy	Tuyauterie	Conjunto de tubería
6		(A,B)	1	Washer	Rondelle	Arandela
7		(A,B)	1	Bracket	Patte de fixation	Pata de fijación
8	339228X1	M8 x 12	2	Screw	Vis	Tornillo
9	339374X1	M8	2	Washer, Lock	Rondelle de blocage	Arandela de freno
10		(A,B)	1	Washer	Rondelle	Arandela
11		(A,B)	1	Nut	Écrou	Tuerca
12		(A,B) Orange	1	Hose Assy	Ensemble de flexible	Flexible, Conj.
13		(A,B)	1	Elbow	Coude	Codo
14		13 (A,B)	1	Elbow	Coude	Codo
15		13 (A,B) Ref. 13	1	O-Ring	Joint torique	Junta de tipo O
16	6101736M92	Blue	1	Hose Assy	Ensemble de flexible	Flexible, Conj.
17	6102943M91	Orange	1	Hose Assy	Ensemble de flexible	Flexible, Conj.
18	6102940M91	Blue	1	Hose Assy	Ensemble de flexible	Flexible, Conj.
19	515-23270		1	Clip	Clip	Clip
20	515-23206		1	Clip	Clip	Clip

A Without Hose Burst
 Sans éclatement de tuyau
 Sin rotura de tubo flexible

B See hose burst section
 Voir la section éclatement de tuyau
 Ver la sección de rotura de tubo flexible



820
 TX760B

801 802 803 804 831 832

76044C05.1

6199042M3

1

Jan-06

Digger Hydraulics
Circuit Hydraulique Défonceuse
Circuito hidráulico equipo retro

Centremount
Montage de Pelle Central
Excavadora de montaje central

Boom Cylinder
Vérin de Flèche
Gato de pluma

Std. Spec.
 Std. Spec.
 Std. Spec.

C-76044-06.1-A

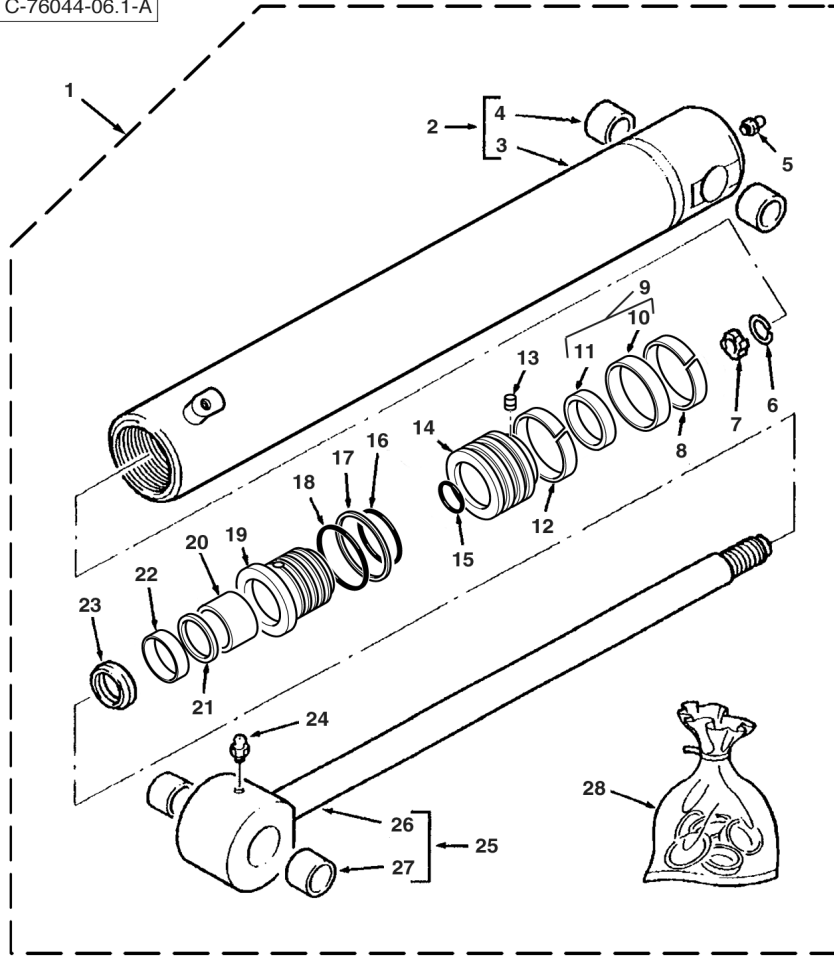

1	5000121M91		76044C05.1 1	1	Cylinder Assy	Ensemble de vérin	Gato, Conj.
2	5003974M91	1		1	Cylinder	Cylindre	Cilindro
3		2	Ref. 2	1	Tube, Cylinder	Cylindre de vérin	Cilindro de gato
4		2 (C)		2	Bushing	Bague	Anillo
5	339608X1	1		1	Fitting, Grease	Graisseur	Engrasador
6	1609899M1	1		1	Ring, Snap	Anneau d'arrêt	Anillo de resorte
7	1609328M1	1		1	Ring	Anneau	Aro
8	3442376M1	1 (A)		1	Ring	Anneau	Aro
9	3485249M91	1 (A)		1	Seal	Joint	Junta
10		9	Ref. 9	1	Seal	Joint	Junta
11		9	Ref. 9	1	Seal	Joint	Junta
12	3442376M1	1		1	Ring	Anneau	Aro
13	3402928M1	1		1	Screw	Vis	Tornillo
14	5003980M1	1		1	Piston	Piston	Pistón
15	3007182X1	1 (A)		1	O-Ring	Joint torique	Junta de tipo O
16	359201X1	1 (A)		1	O-Ring	Joint torique	Junta de tipo O
17	1024334M1	1 (A)		1	Ring	Anneau	Aro
18	3487909M1	1 (A)		1	O-Ring	Joint torique	Junta de tipo O
19	5003979M1	1		1	Bearing	Coussinet	Cojinete
20	3623193M1	1 (A)		1	Ring	Anneau	Aro
21	3443388M1	1 (A)		1	Ring	Anneau	Aro
22	3443472M1	1 (A)		1	Seal	Joint	Junta
23	3403385M1	1 (A)		1	Ring, Wiper	Joint de racleur	Junta raspador
24	339608X1	1		1	Fitting, Grease	Graisseur	Engrasador
25	3441629M91	1		1	Rod, Piston	Tige de vérin	Vástago cilindro
26		25	Ref. 25	1	Rod, Piston	Tige de vérin	Vástago cilindro
27	3484843M1	25		1	Bush	Bague	Casquillo
28	5004400M91	(B)		1	Kit, Seal	Pochette de joints	Juego de juntas

A Included in kit marked (B)
 Inclus dans jeu marqué (B)
 Incluido en juego marcado (B)
 Part number to be advised
 Référence pièce à demander
 Indicar número de pieza

B Contains items marked (A)
 Comprend les pièces marquées (A)
 Incluye las piezas marcadas (A)



820
 TX760B

801 802 803 804 831 832

76044C06.1

6199042M3

1

Jan-06

Digger Hydraulics
Circuit Hydraulique Défonceuse
Circuito hidráulico equipo retro

Centremount
Montage de Pelle Central
Excavadora de montaje central

Swing Components
Organes de Rotation
Componentes de rotación

Std. Spec.
 Std. Spec.
 Std. Spec.

C-76044-07.1-A

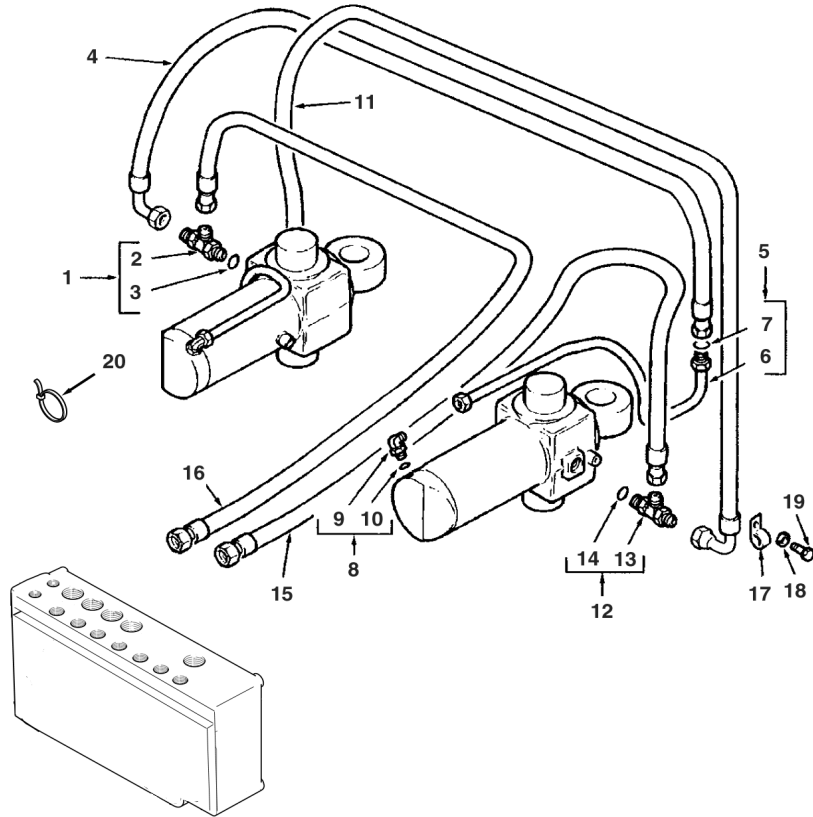

1	358728X91		1	Tee	Raccord en T	Te
2		1	▶ Ref. 1	1	Tee	Raccord en T
3	831497M1	1		1	O-Ring	Joint torique
4	6100716M91	840 mm		1	Hose Assy	Ensemble de flexible
5	6100587M91	▶		1	Tube Assy	Tuyauterie
5	6100589M91	▶		1	Tube Assy	Tuyauterie
6		5	▶ Ref. 5	1	Tube	Tube
7	394923X1	5		1	O-Ring	Joint torique
8	357197X91			2	Elbow, 90°	Coude à 90°
9		8	▶ Ref. 8	1	Elbow	Coude
10	831452M1	8		1	O-Ring	Joint torique
11	6100716M91	840 mm		1	Hose Assy	Ensemble de flexible
12	358728X91			1	Tee	Raccord en T
13		12	▶ Ref. 12	1	Tee	Raccord en T
14	831497M1	12		1	O-Ring	Joint torique
15	6100715M92	Purple 700mm		1	Hose Assy	Ensemble de flexible
16	6101866M93	Green 700mm		1	Hose Assy	Ensemble de flexible
17	3517114M2			2	Clip, Mounting	Collier de fixation
18	385361X1	M8		2	Washer	Rondelle
19	339228X1	M8 x 12		2	Screw	Vis
20	1862425M1			1	Tie, Cable	Attache câble



820
TX760B

801 802 803 804 831 832

76044C07.1

6199042M3

1

Jan-06

Digger Hydraulics
Circuit Hydraulique Défonceuse
Circuito hidráulico equipo retro

Centremount
Montage de Pelle Central
Excavadora de montaje central

Bucket
 Godet
 Cuchara

Std. Spec.
 Std. Spec.
 Std. Spec.

C-76045-01.1-A

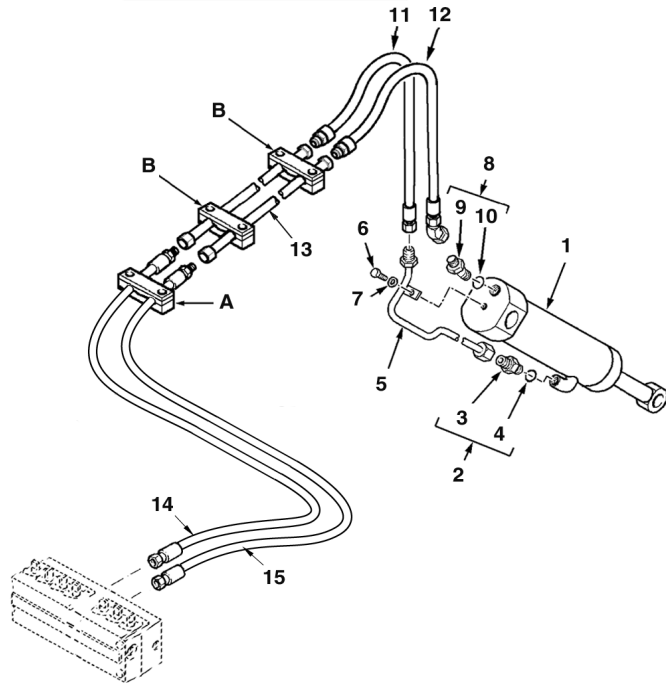
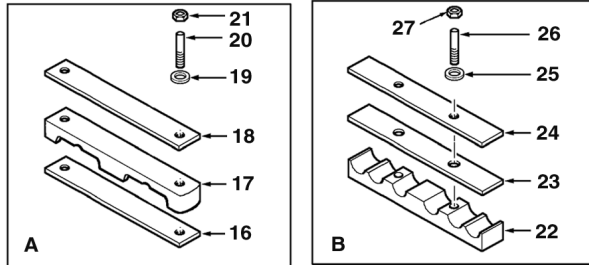

1	5000126M91	76045C02.1 1	1	Cylinder Assy	Ensemble de vérin	Gato, Conj.
2	835013M91		1	Connector Assy	Ensemble connexion	Conexión, Conj.
3		2 Ref. 2	1	Union	Union	Unión
4	835024M1	2	1	O-Ring	Joint torique	Junta de tipo O
5	6101540M91		1	Tube Assy	Tuyauterie	Conjunto de tubería
6	339123X1	M8 x 20	1	Bolt	Boulon	Perno
7	385361X1	M8	1	Washer	Rondelle	Arandela
8	835010M91		1	Elbow, 45°	Coude à 45°	Codo, 45°
9		8 Ref. 8	1	Elbow	Coude	Codo
10	835024M1	8	1	O-Ring	Joint torique	Junta de tipo O
11		(A)Brown	1	Hose Assy	Ensemble de flexible	Flexible, Conj.
12		(A)White	1	Hose Assy	Ensemble de flexible	Flexible, Conj.
13	6101771M91		2	Tube Assy	Tuyauterie	Conjunto de tubería
14	6102945M91	Brown	1	Hose Assy	Ensemble de flexible	Flexible, Conj.
15	6102942M91	White	1	Hose Assy	Ensemble de flexible	Flexible, Conj.
16	6102128M1		1	Pad	Plaque antidérapante	Cinta antideslizante
17	6102122M1		1	Bracket, Clamp	Bride de fixation	Brida de fijación
18	6102130M1		1	Plate	Plaque	Placa
19	390972X1	M8	2	Washer	Rondelle	Arandela
20	3516075M1	M8 x 65	2	Stud	Goujon	Espárrago
21	394367X1	M8	2	Nut, Lock	Écrou de blocage	Tuerca de retención
22	6102126M1		2	Bracket, Clamp	Bride de fixation	Brida de fijación
23	6102145M1		2	Pad	Plaque antidérapante	Cinta antideslizante
24	6102124M1		2	Plate	Plaque	Placa
25	390972X1	M8	4	Washer	Rondelle	Arandela
26	6108049M1		4	Stud	Goujon	Espárrago
27	394367X1	M8	4	Nut, Lock	Écrou de blocage	Tuerca de retención

A See extendahoe hydraulics section
 Voir la section circuit hydraulique extendahoe
 Ver la sección de la circuito hidráulico extendahoe



820 860
 TX760B TX860B

801 802 803 804 817 831 832

76045C01.1

6199042M3

1

Jan-06

Digger Hydraulics
Circuit Hydraulique Défonceuse
Circuito hidráulico equipo retro

Centremount
Montage de Pelle Central
Excavadora de montaje central

Bucket Cylinder
Vérin de Godet
Gato de cuchara

Std. Spec.
 Std. Spec.
 Std. Spec.

C-76045-02.1-A

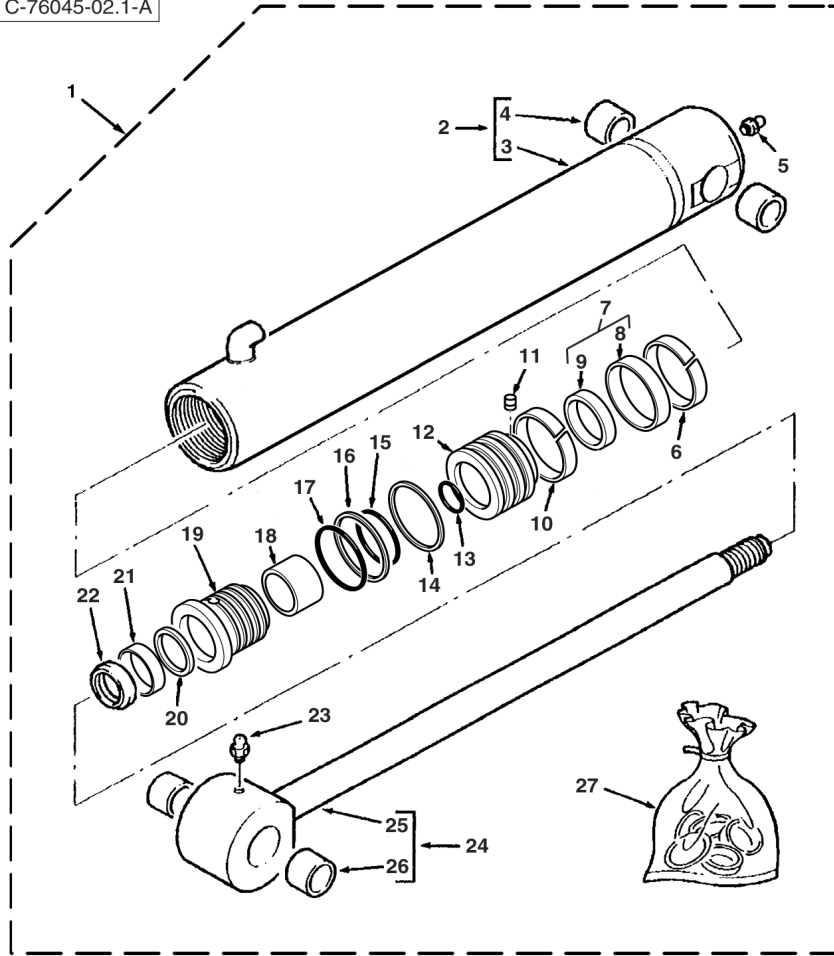

1	5000126M91		76045C01.1 1	1	Cylinder Assy	Ensemble de vérin	Gato, Conj.
2	5004008M91	1		1	Cylinder	Cylindre	Cilindro
3		3	Ref. 2	1	Tube, Cylinder	Cylindre de vérin	Cilindro de gato
4		3 (C)		1	Bushing	Bague	Anillo
5	339608X1	1		1	Fitting, Grease	Graisser	Engrasador
6	3485892M1	1 (A)		1	Ring, Sealing	Bague d'étanchéité	Anillo, Estanqueidad
7	3485245M91	1 (A)		1	Seal Assy	Ensemble de joint	Junta, Conj.
8		7	Ref. 7	1	Seal	Joint	Junta
9		7	Ref. 7	1	Ring	Anneau	Aro
10	3485892M1	1 (A)		1	Ring, Sealing	Bague d'étanchéité	Anillo, Estanqueidad
11	3402928M1	1		1	Screw	Vis	Tornillo
12	3623372M1	1		1	Piston	Piston	Pistón
13	359186X1	1 (A)		1	O-Ring	Joint torique	Junta de tipo O
14	3623061M1	1		1	Ring, Piston	Segment de piston	Segmento de pistón
15	359193X1	1 (A)		1	O-Ring	Joint torique	Junta de tipo O
16	1606735M1	1 (A)		1	Ring, Backup	Contre-joint	ContraJunta
17	3487207M1	1 (A)		1	O-Ring	Joint torique	Junta de tipo O
18	3484615M1	1 (A)		1	Ring	Anneau	Aro
19	3623371M1	1		1	Bearing	Coussinet	Cojinete
20	3484055M1	1 (A)		1	Ring	Anneau	Aro
21	3485185M1	1 (A)		1	Seal	Joint	Junta
22	3487015M1	1 (A)		1	Ring	Anneau	Aro
23	339608X1	1		1	Fitting, Grease	Graisser	Engrasador
24	5004012M91	1		1	Rod, Piston	Tige de vérin	Vástago cilindro
25		24	Ref. 24	1	Rod, Piston	Tige de vérin	Vástago cilindro
26		24 (C)		1	Bushing	Bague	Anillo
27	3623373M91		(B)	1	Kit, Seal	Pochette de joints	Juego de juntas

A Contains items marked (A)
 Comprend les pièces marquées (A)
 Incluye las piezas marcadas (A)
 C Part number to be advised
 Référence pièce à demander
 Indicar número de pieza

B Included in kit marked (B)
 Inclus dans jeu marqué (B)
 Incluido en juego marcado (B)



820 860
 TX760B TX860B

801 802 803 804 817 831 832

76045C02.1

6199042M3

1

Jan-06

Digger Hydraulics
Circuit Hydraulique Défonceuse
Circuito hidráulico equipo retro

Centremount
Montage de Pelle Central
Excavadora de montaje central

Telescopic Dipper
Balancier Téléscopique
Balancín telescópico

Std. Spec.
 Std. Spec.
 Std. Spec.

C-76045-03.1-A

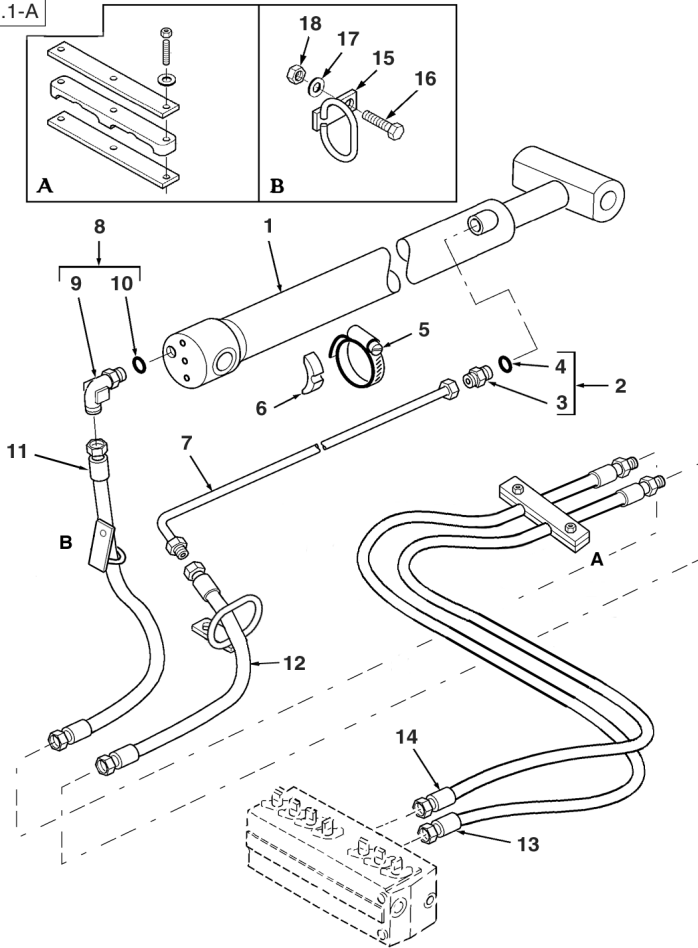

1	5000124M91	76045C04.1 1	1	Cylinder Assy	Ensemble de vérin	Gato, Conj.
2	835013M91		1	Connector Assy	Ensemble connexion	Conexión, Conj.
3		2 Ref. 2	1	Union	Union	Unión
4	835024M1	2	1	O-Ring	Joint torique	Junta de tipo O
5	3517733M1		1	Clamp	Collier de serrage	Argolla de cierre
6	L79937		1	Spacer	Entretoise	Travesa
7		(A,B)	1	Tube Assy	Tuyauterie	Conjunto de tubería
8		(A,B)	1	Elbow	Coude	Codo
9		8 (A,B) Ref. 8	1	Elbow	Coude	Codo
10		8 (A,B)	1	O-Ring	Joint torique	Junta de tipo O
11	6101738M91	Yellow	1	Hose Assy	Ensemble de flexible	Flexible, Conj.
12	6101737M91	Red	1	Hose Assy	Ensemble de flexible	Flexible, Conj.
13	6102941M91	Yellow	1	Hose Assy	Ensemble de flexible	Flexible, Conj.
14	6102944M91	Red	1	Hose Assy	Ensemble de flexible	Flexible, Conj.
15	6101491M92		2	Support Assy	Ensemble de support	Apoyadero, Conj.
16	339761X1	M8 x 25	2	Screw	Vis	Tornillo
17	390972X1	M8	2	Washer	Rondelle	Arandela
18	394367X1	M8	2	Nut, Lock	Écrou de blocage	Tuerca de retención

A Without Hose Burst
 Sans éclatement de tuyau
 Sin rotura de tubo flexible

B See hose burst section
 Voir la section éclatement de tuyau
 Ver la sección de rotura de tubo flexible



820 860
 TX760B TX860B

801 802 803 804 817 831 832

76045C03.1

6199042M3

1

Jan-06

Digger Hydraulics
Circuit Hydraulique Défonceuse
Circuito hidráulico equipo retro

Centremount
Montage de Pelle Central
Excavadora de montaje central

Dipper Cylinder
Vérin de Balancier
Gato de balancín

Std. Spec.
 Std. Spec.
 Std. Spec.

C-76045-04.1-A

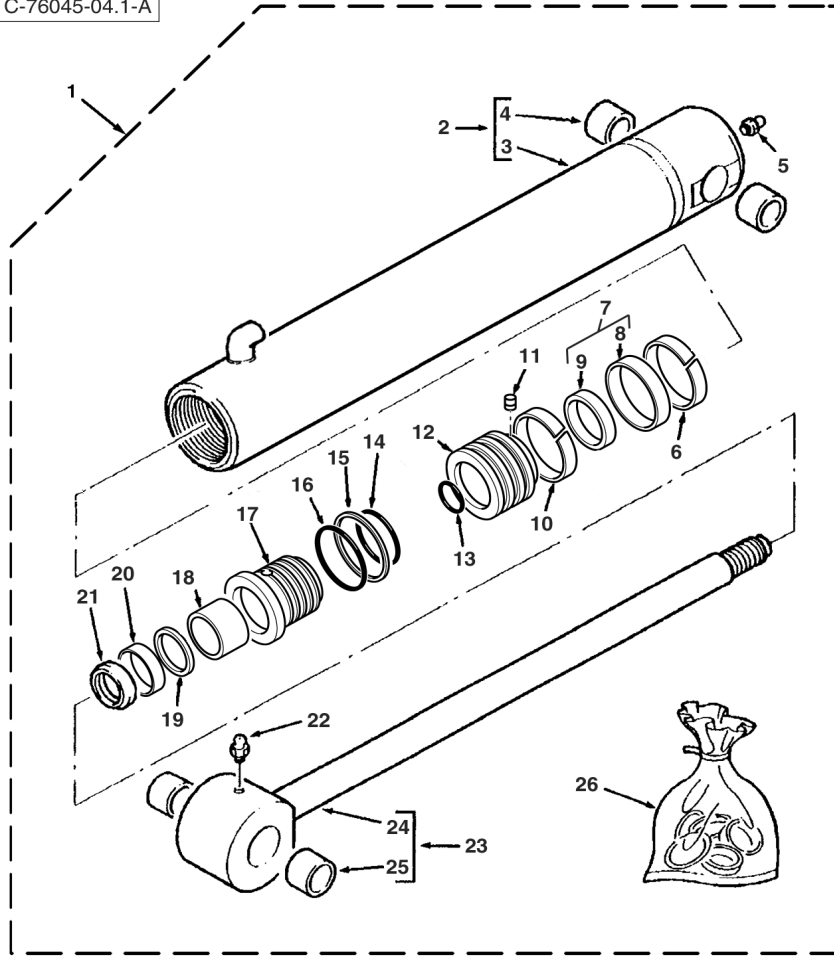

1	5000124M91		76045C03.1 1	1	Cylinder Assy	Ensemble de vérin	Gato, Conj.
2	5003982M91	1		1	Cylinder	Cylindre	Cilindro
3		2	Ref. 2	1	Tube, Cylinder	Cylindre de vérin	Cilindro de gato
4	3484843M1	2		1	Bush	Bague	Casquillo
5	339608X1	1		1	Fitting, Grease	Graisneur	Engrasador
6	3485891M1	1 (A)		1	Ring	Anneau	Aro
7	3485247M91	1 (A)		1	Seal Assy	Ensemble de joint	Junta, Conj.
8		7	Ref. 7	1	Seal	Joint	Junta
9		7	Ref. 7	1	Ring	Anneau	Aro
10	3485891M1	1 (A)		1	Ring	Anneau	Aro
11	3402928M1	1		1	Screw	Vis	Tornillo
12	5003989M1	1		1	Piston	Piston	Pistón
13	3007182X1	1 (A)		1	O-Ring	Joint torique	Junta de tipo O
14	359196X1	1 (A)		1	O-Ring	Joint torique	Junta de tipo O
15	378545X1	1 (A)		1	Ring	Anneau	Aro
16	3487908M1	1 (A)		1	O-Ring	Joint torique	Junta de tipo O
17	5003988M1	1		1	Bearing	Coussinet	Cojinete
18	3623193M1	1 (A)		1	Ring	Anneau	Aro
19	3443388M1	1 (A)		1	Ring	Anneau	Aro
20	3443472M1	1 (A)		1	Seal	Joint	Junta
21	3403385M1	1 (A)		1	Ring, Wiper	Joint de racler	Junta raspador
22	339608X1	1		1	Fitting, Grease	Graisneur	Engrasador
23	5003985M91	1		1	Rod, Piston	Tige de vérin	Vástago cilindro
24		23	Ref. 23	1	Rod, Piston	Tige de vérin	Vástago cilindro
25	3484843M1	23		1	Bush	Bague	Casquillo
26	5004401M91		(B)	1	Kit, Seal	Pochette de joints	Juego de juntas

A Included in kit marked (B)
 Inclus dans jeu marqué (B)
 Incluido en juego marcado (B)

B Contains items marked (A)
 Comprend les pièces marquées (A)
 Incluye las piezas marcadas (A)



820 860
 TX760B TX860B

801 802 803 804 817 831 832

76045C04.1

6199042M3

1

Jan-06

Digger Hydraulics
Circuit Hydraulique Défonceuse
Circuito hidráulico equipo retro

Centremount
Montage de Pelle Central
Excavadora de montaje central

Boom 4.5m
 Flèche 4.5m
 Pluma 4.5m

Std. Spec.
 Std. Spec.
 Std. Spec.

C-76045-05.1-A

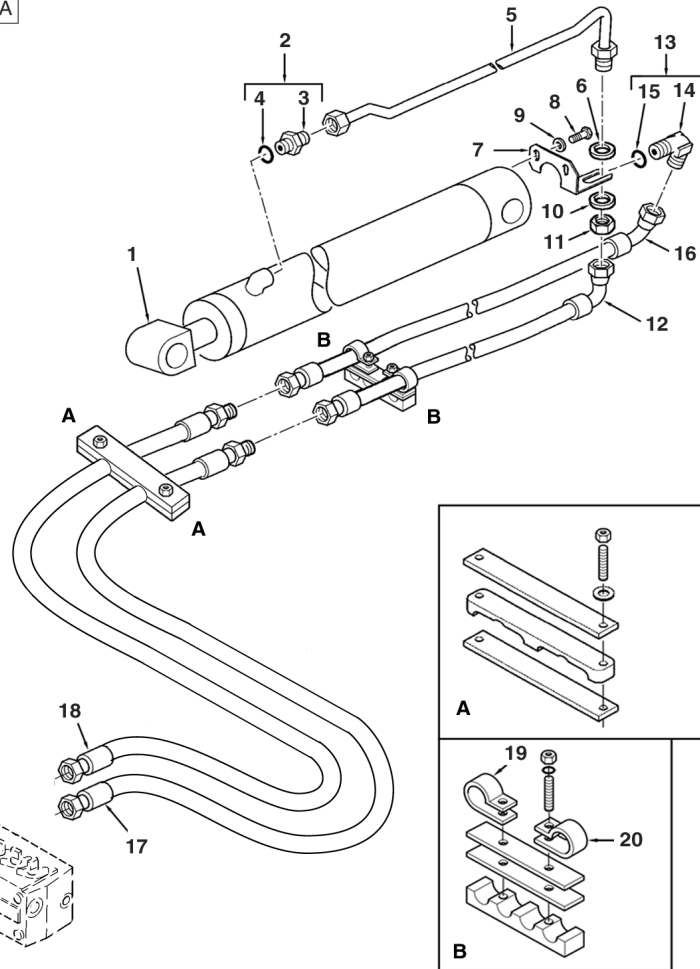

1	5000121M91	76045C06.1 1	1	Cylinder Assy	Ensemble de vérin	Gato, Conj.
2	835013M91		1	Connector Assy	Ensemble connexion	Conexión, Conj.
3		2 Ref. 2	1	Union	Union	Unión
4	835024M1	2	1	O-Ring	Joint torique	Junta de tipo O
5		(A,B)	1	Tube Assy	Tuyauterie	Conjunto de tubería
6		(A,B)	1	Washer	Rondelle	Arandela
7		(A,B)	1	Bracket	Patte de fixation	Pata de fijación
8	339228X1	M8 x 12	2	Screw	Vis	Tornillo
9	339374X1	M8	2	Washer, Lock	Rondelle de blocage	Arandela de freno
10		(A,B)	1	Washer	Rondelle	Arandela
11		(A,B)	1	Nut	Écrou	Tuerca
12		(A,B) Orange	1	Hose Assy	Ensemble de flexible	Flexible, Conj.
13		(A,B)	1	Elbow	Coude	Codo
14		13 (A,B)	1	Elbow	Coude	Codo
15		13 (A,B) Ref. 13	1	O-Ring	Joint torique	Junta de tipo O
16	6101736M92	Blue	1	Hose Assy	Ensemble de flexible	Flexible, Conj.
17	6102943M91	Orange	1	Hose Assy	Ensemble de flexible	Flexible, Conj.
18	6102940M91	Blue	1	Hose Assy	Ensemble de flexible	Flexible, Conj.
19	515-23270		1	Clip	Clip	Clip
20	515-23206		1	Clip	Clip	Clip

A Without Hose Burst
 Sans éclatement de tuyau
 Sin rotura de tubo flexible

B See hose burst section
 Voir la section éclatement de tuyau
 Ver la sección de rotura de tubo flexible



820 860
 TX760B TX860B

801 802 803 804 817 831 832

76045C05.1

6199042M3

1

Jan-06

Digger Hydraulics
Circuit Hydraulique Défonceuse
Circuito hidráulico equipo retro

Centremount
Montage de Pelle Central
Excavadora de montaje central

Boom Cylinder
Vérin de Flèche
Gato de pluma

Std. Spec.
 Std. Spec.
 Std. Spec.

C-76045-06.1-A

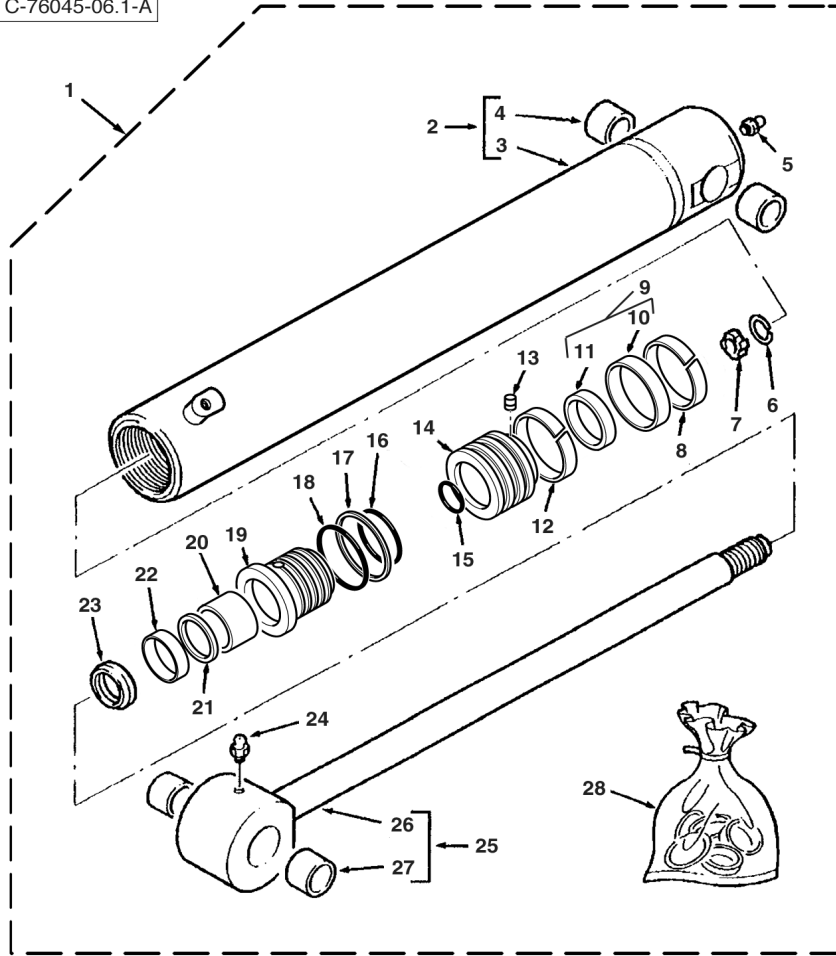

1	5000121M91	76045C05.1 1	1	Cylinder Assy	Ensemble de vérin	Gato, Conj.
2	5003974M91	1	1	Cylinder	Cylindre	Cilindro
3		2	1	Tube, Cylinder	Cylindre de vérin	Cilindro de gato
4		2 (C)	2	Bushing	Bague	Anillo
5	339608X1	1	1	Fitting, Grease	Graisseur	Engrasador
6	1609899M1	1	1	Ring, Snap	Anneau d'arrêt	Anillo de resorte
7	1609328M1	1	1	Ring	Anneau	Aro
8	3442376M1	1 (A)	2	Ring	Anneau	Aro
9	3485249M91	1 (A)	1	Seal	Joint	Junta
10		9	1	Seal	Joint	Junta
11		9	1	Seal	Joint	Junta
12	3442376M1	1	1	Ring	Anneau	Aro
13	3402928M1	1	1	Screw	Vis	Tornillo
14	5003980M1	1	1	Piston	Piston	Pistón
15	3007182X1	1 (A)	1	O-Ring	Joint torique	Junta de tipo O
16	359201X1	1 (A)	1	O-Ring	Joint torique	Junta de tipo O
17	1024334M1	1 (A)	1	Ring	Anneau	Aro
18	3487909M1	1 (A)	1	O-Ring	Joint torique	Junta de tipo O
19	5003979M1	1	1	Bearing	Coussinet	Cojinete
20	3623193M1	1 (A)	1	Ring	Anneau	Aro
21	3443388M1	1 (A)	1	Ring	Anneau	Aro
22	3443472M1	1 (A)	1	Seal	Joint	Junta
23	3403385M1	1 (A)	1	Ring, Wiper	Joint de racleur	Junta raspador
24	339608X1	1	1	Fitting, Grease	Graisseur	Engrasador
25	3441629M91	1	1	Rod, Piston	Tige de vérin	Vástago cilindro
26		25	1	Rod, Piston	Tige de vérin	Vástago cilindro
27	3484843M1	25	1	Bush	Bague	Casquillo
28	5004400M91	(B)	1	Kit, Seal	Pochette de joints	Juego de juntas

A Included in kit marked (B)
 Inclus dans jeu marqué (B)
 Incluido en juego marcado (B)
 Part number to be advised
 Référence pièce à demander
 Indicar número de pieza

B Contains items marked (A)
 Comprend les pièces marquées (A)
 Incluye las piezas marcadas (A)



820 860
 TX760B TX860B

801 802 803 804 817 831 832

76045C06.1

6199042M3

1

Jan-06

Digger Hydraulics
Circuit Hydraulique Défonceuse
Circuito hidráulico equipo retro

Centremount
Montage de Pelle Central
Excavadora de montaje central

Swing Components
Organes de Rotation
Componentes de rotación

Std. Spec.
 Std. Spec.
 Std. Spec.

C-76045-07.1-A

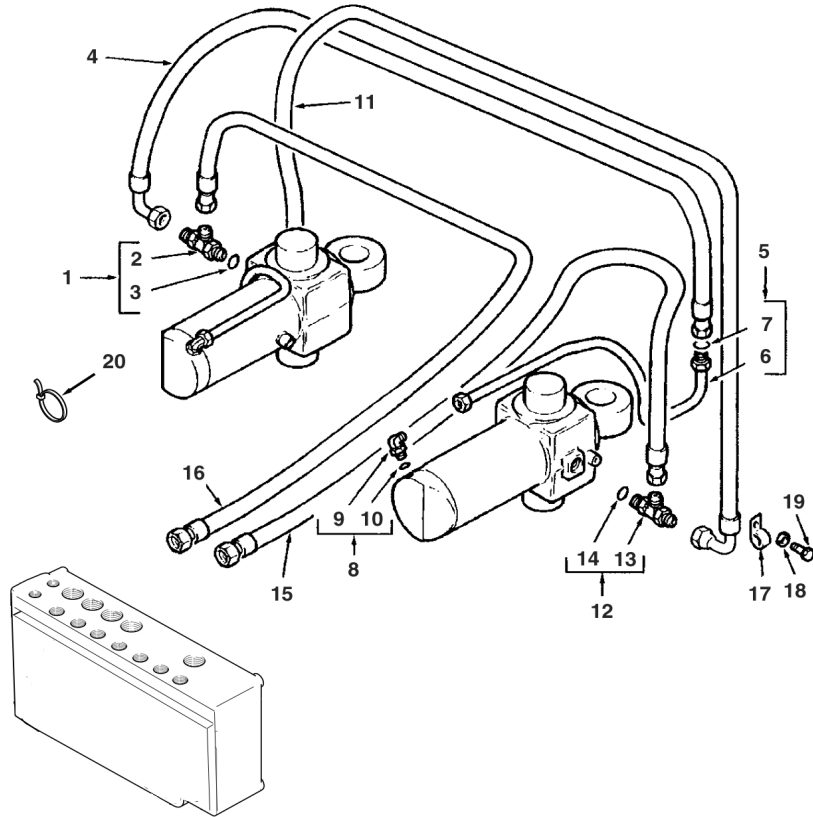

1	358728X91			1	Tee	Raccord en T	Te
2		1	▶ Ref. 1	1	Tee	Raccord en T	Te
3	831497M1	1		1	O-Ring	Joint torique	Junta de tipo O
4	6100716M91	840 mm		1	Hose Assy	Ensemble de flexible	Flexible, Conj.
5	6100587M91		◀	1	Tube Assy	Tuyauterie	Conjunto de tubería
5	6100589M91		▶	1	Tube Assy	Tuyauterie	Conjunto de tubería
6		5	▶ Ref. 5	1	Tube	Tube	Tubo
7	394923X1	5		1	O-Ring	Joint torique	Junta de tipo O
8	357197X91			2	Elbow, 90°	Coude à 90°	Codo, 90°
9		8	▶ Ref. 8	1	Elbow	Coude	Codo
10	831452M1	8		1	O-Ring	Joint torique	Junta de tipo O
11	6100716M91	840 mm		1	Hose Assy	Ensemble de flexible	Flexible, Conj.
12	358728X91			1	Tee	Raccord en T	Te
13		12	▶ Ref. 12	1	Tee	Raccord en T	Te
14	831497M1	12		1	O-Ring	Joint torique	Junta de tipo O
15	6100715M92	Purple 700mm		1	Hose Assy	Ensemble de flexible	Flexible, Conj.
16	6101866M93	Green 700mm		1	Hose Assy	Ensemble de flexible	Flexible, Conj.
17	3517114M2			2	Clip, Mounting	Collier de fixation	Argolla de fijación
18	385361X1	M8		2	Washer	Rondelle	Arandela
19	339228X1	M8 x 12		2	Screw	Vis	Tornillo
20	1862425M1			1	Tie, Cable	Attache câble	Enlace de Cable



820 860
 TX760B TX860B

801 802 803 804 817 831 832

76045C07.1

6199042M3

1

Jan-06

Digger Hydraulics
Circuit Hydraulique Défonceuse
Circuito hidráulico equipo retro

Centremount
Montage de Pelle Central
Excavadora de montaje central

Bucket
 Godet
 Cuchara

High Spec.
 High Spec.
 High Spec.

C-76046-01.1-A

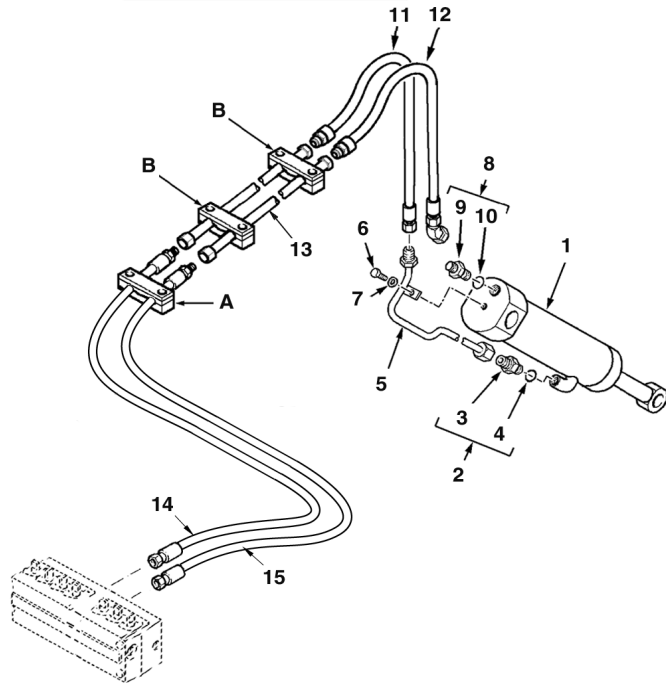
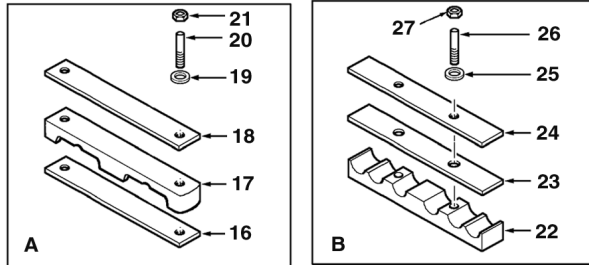

1	5000126M91	76046C02.1 1	1	Cylinder Assy	Ensemble de vérin	Gato, Conj.
2	835013M91		1	Connector Assy	Ensemble connexion	Conexión, Conj.
3		2 Ref. 2	1	Union	Union	Unión
4	835024M1	2	1	O-Ring	Joint torique	Junta de tipo O
5	6101540M91		1	Tube Assy	Tuyauterie	Conjunto de tubería
6	339123X1	M8 x 20	1	Bolt	Boulon	Perno
7	385361X1	M8	1	Washer	Rondelle	Arandela
8	835013M91		1	Connector Assy	Ensemble connexion	Conexión, Conj.
9		8 Ref. 8	1	Union	Union	Unión
10	835024M1	8	1	O-Ring	Joint torique	Junta de tipo O
11	6102309M91	Brown	1	Hose Assy	Ensemble de flexible	Flexible, Conj.
12	6107024M91	White	1	Hose Assy	Ensemble de flexible	Flexible, Conj.
13	6101771M91		2	Tube Assy	Tuyauterie	Conjunto de tubería
14	6102945M91	Brown	1	Hose Assy	Ensemble de flexible	Flexible, Conj.
15	6102942M91	White	1	Hose Assy	Ensemble de flexible	Flexible, Conj.
16	6102128M1		1	Pad	Plaque antidérapante	Cinta antideslizante
17	6102122M1		1	Bracket, Clamp	Bride de fixation	Brida de fijación
18	6102130M1		1	Plate	Plaque	Placa
19	390972X1	M8	2	Washer	Rondelle	Arandela
20	3516075M1	M8 x 65	2	Stud	Goujon	Espárrago
21	394367X1	M8	2	Nut, Lock	Écrou de blocage	Tuerca de retención
22	6102126M1		2	Bracket, Clamp	Bride de fixation	Brida de fijación
23	6102145M1		2	Pad	Plaque antidérapante	Cinta antideslizante
24	6102124M1		2	Plate	Plaque	Placa
25	390972X1	M8	4	Washer	Rondelle	Arandela
26	6108049M1		4	Stud	Goujon	Espárrago
27	394367X1	M8	4	Nut, Lock	Écrou de blocage	Tuerca de retención



860 880 970
 TX860B

813 814 821 822 841 842 851 852 922

76046C01.1

6199042M3

1

Jan-06

Digger Hydraulics
Circuit Hydraulique Défonceuse
Circuito hidráulico equipo retro

Centremount
Montage de Pelle Central
Excavadora de montaje central

Bucket Cylinder
Vérin de Godet
Gato de cuchara

High Spec.
 High Spec.
 High Spec.

C-76046-02.1-A

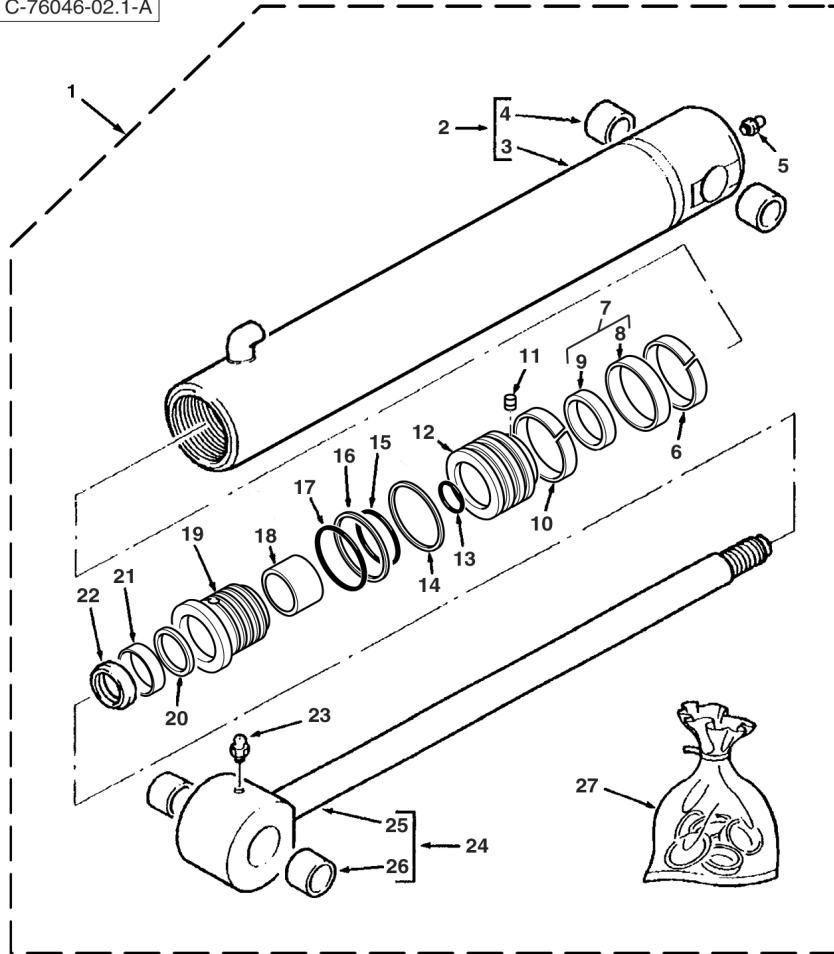

1	5000126M91		76046C01.1 1	1	Cylinder Assy	Ensemble de vérin	Gato, Conj.
2	5004008M91	1		1	Cylinder	Cylindre	Cilindro
3		3	Ref. 2	1	Tube, Cylinder	Cylindre de vérin	Cilindro de gato
4		3 (C)		1	Bushing	Bague	Anillo
5	339608X1	1		1	Fitting, Grease	Graisser	Engrasador
6	3485892M1	1 (A)		1	Ring, Sealing	Bague d'étanchéité	Anillo, Estanqueidad
7	3485245M91	1 (A)		1	Seal Assy	Ensemble de joint	Junta, Conj.
8		7	Ref. 7	1	Seal	Joint	Junta
9		7	Ref. 7	1	Ring	Anneau	Aro
10	3485892M1	1 (A)		1	Ring, Sealing	Bague d'étanchéité	Anillo, Estanqueidad
11	3402928M1	1		1	Screw	Vis	Tornillo
12	3623372M1	1		1	Piston	Piston	Pistón
13	359186X1	1 (A)		1	O-Ring	Joint torique	Junta de tipo O
14	3623061M1	1		1	Ring, Piston	Segment de piston	Segmento de pistón
15	359193X1	1 (A)		1	O-Ring	Joint torique	Junta de tipo O
16	1606735M1	1 (A)		1	Ring, Backup	Contre-joint	ContraJunta
17	3487207M1	1 (A)		1	O-Ring	Joint torique	Junta de tipo O
18	3484615M1	1 (A)		1	Ring	Anneau	Aro
19	3623371M1	1		1	Bearing	Coussinet	Cojinete
20	3484055M1	1 (A)		1	Ring	Anneau	Aro
21	3485185M1	1 (A)		1	Seal	Joint	Junta
22	3487015M1	1 (A)		1	Ring	Anneau	Aro
23	339608X1	1		1	Fitting, Grease	Graisser	Engrasador
24	5004012M91	1		1	Rod, Piston	Tige de vérin	Vástago cilindro
25		24	Ref. 24	1	Rod, Piston	Tige de vérin	Vástago cilindro
26		24 (C)		1	Bushing	Bague	Anillo
27	3623373M91		(B)	1	Kit, Seal	Pochette de joints	Juego de juntas

A Contains items marked (A)
 Comprend les pièces marquées (A)
 Incluye las piezas marcadas (A)
 C Part number to be advised
 Référence pièce à demander
 Indicar número de pieza

B Included in kit marked (B)
 Inclus dans jeu marqué (B)
 Incluido en juego marcado (B)



860 880 970
 TX860B

813 814 821 822 841 842 851 852 922

76046C02.1

6199042M3

1

Jan-06

Digger Hydraulics
Circuit Hydraulique Défonceuse
Circuito hidráulico equipo retro

Centremount
Montage de Pelle Central
Excavadora de montaje central

Standard Dipper
Balancier Standard
Balancín estándar

High Spec.
 High Spec.
 High Spec.

C-76046-03.1-A

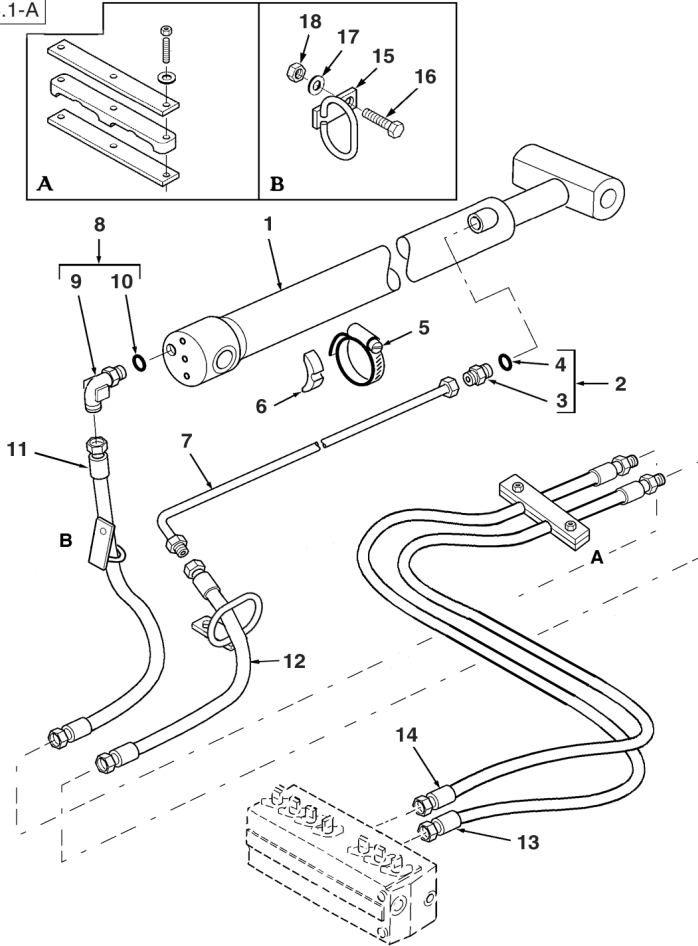

1	5000124M91	76046C04.1 1	1	Cylinder Assy	Ensemble de vérin	Gato, Conj.
2	835013M91		1	Connector Assy	Ensemble connexion	Conexión, Conj.
3		2 Ref. 2	1	Union	Union	Unión
4	835024M1	2	1	O-Ring	Joint torique	Junta de tipo O
5	3517733M1		1	Clamp	Collier de serrage	Argolla de cierre
6	L79937		1	Spacer	Entretoise	Travesa
7		(A,B)	1	Tube Assy	Tuyauterie	Conjunto de tubería
8		(A,B)	1	Elbow	Coude	Codo
9		(A,B) Ref. 8	1	Elbow	Coude	Codo
10		(A,B)	1	O-Ring	Joint torique	Junta de tipo O
11	6101738M91	Yellow	1	Hose Assy	Ensemble de flexible	Flexible, Conj.
12	6101737M91	Red	1	Hose Assy	Ensemble de flexible	Flexible, Conj.
13	6102941M91	Yellow	1	Hose Assy	Ensemble de flexible	Flexible, Conj.
14	6102944M91	Red	1	Hose Assy	Ensemble de flexible	Flexible, Conj.
15	6101491M92		2	Support Assy	Ensemble de support	Apoyadero, Conj.
16	339761X1	M8 x 25	2	Screw	Vis	Tornillo
17	390972X1	M8	2	Washer	Rondelle	Arandela
18	394367X1	M8	2	Nut, Lock	Écrou de blocage	Tuerca de retención

A Without Hose Burst
 Sans éclatement de tuyau
 Sin rotura de tubo flexible

B See hose burst section
 Voir la section éclatement de tuyau
 Ver la sección de rotura de tubo flexible



860 880 970
 TX860B

813 814 821 822 841 842 851 852 922

76046C03.1

6199042M3

1

Jan-06

Digger Hydraulics
Circuit Hydraulique Défonceuse
Circuito hidráulico equipo retro

Centremount
Montage de Pelle Central
Excavadora de montaje central

Dipper Cylinder
Vérin de Balancier
Gato de balancín

High Spec.
 High Spec.
 High Spec.

C-76046-04.1-A

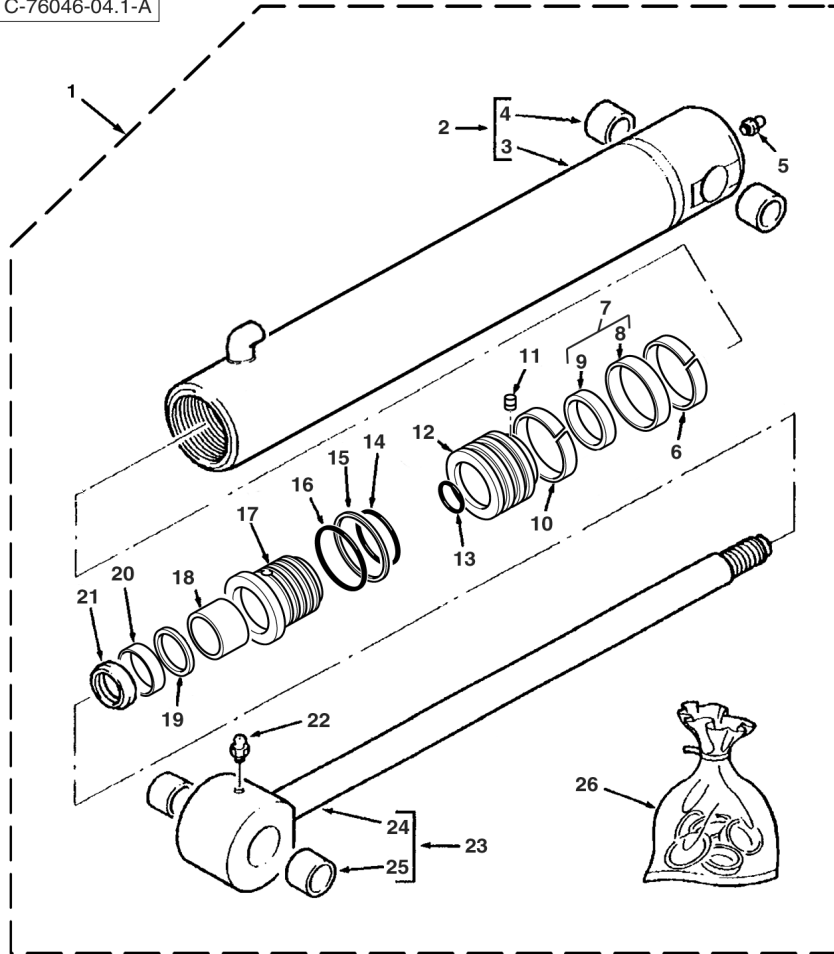

1	5000124M91		76046C03.1 1	1	Cylinder Assy	Ensemble de vérin	Gato, Conj.
2	5003982M91	1		1	Cylinder	Cylindre	Cilindro
3		2	Ref. 2	1	Tube, Cylinder	Cylindre de vérin	Cilindro de gato
4	3484843M1	2		1	Bush	Bague	Casquillo
5	339608X1	1		1	Fitting, Grease	Graisneur	Engrasador
6	3485891M1	1 (A)		1	Ring	Anneau	Aro
7	3485247M91	1 (A)		1	Seal Assy	Ensemble de joint	Junta, Conj.
8		7	Ref. 7	1	Seal	Joint	Junta
9		7	Ref. 7	1	Ring	Anneau	Aro
10	3485891M1	1 (A)		1	Ring	Anneau	Aro
11	3402928M1	1		1	Screw	Vis	Tornillo
12	5003989M1	1		1	Piston	Piston	Pistón
13	3007182X1	1 (A)		1	O-Ring	Joint torique	Junta de tipo O
14	359196X1	1 (A)		1	O-Ring	Joint torique	Junta de tipo O
15	378545X1	1 (A)		1	Ring	Anneau	Aro
16	3487908M1	1 (A)		1	O-Ring	Joint torique	Junta de tipo O
17	5003988M1	1		1	Bearing	Coussinet	Cojinete
18	3623193M1	1 (A)		1	Ring	Anneau	Aro
19	3443388M1	1 (A)		1	Ring	Anneau	Aro
20	3443472M1	1 (A)		1	Seal	Joint	Junta
21	3403385M1	1 (A)		1	Ring, Wiper	Joint de racler	Junta raspador
22	339608X1	1		1	Fitting, Grease	Graisneur	Engrasador
23	5003985M91	1		1	Rod, Piston	Tige de vérin	Vástago cilindro
24		23	Ref. 23	1	Rod, Piston	Tige de vérin	Vástago cilindro
25	3484843M1	23		1	Bush	Bague	Casquillo
26	5004401M91		(B)	1	Kit, Seal	Pochette de joints	Juego de juntas

A Included in kit marked (B)
 Inclus dans jeu marqué (B)
 Incluido en juego marcado (B)

B Contains items marked (A)
 Comprend les pièces marquées (A)
 Incluye las piezas marcadas (A)



860 880 970
 TX860B

813 814 821 822 841 842 851 852 922

76046C04.1

6199042M3

1

Jan-06

Digger Hydraulics
Circuit Hydraulique Défonceuse
Circuito hidráulico equipo retro

Centremount
Montage de Pelle Central
Excavadora de montaje central

Boom 4.5m
 Flèche 4.5m
 Pluma 4.5m

High Spec.
 High Spec.
 High Spec.

C-76046-05.1-A

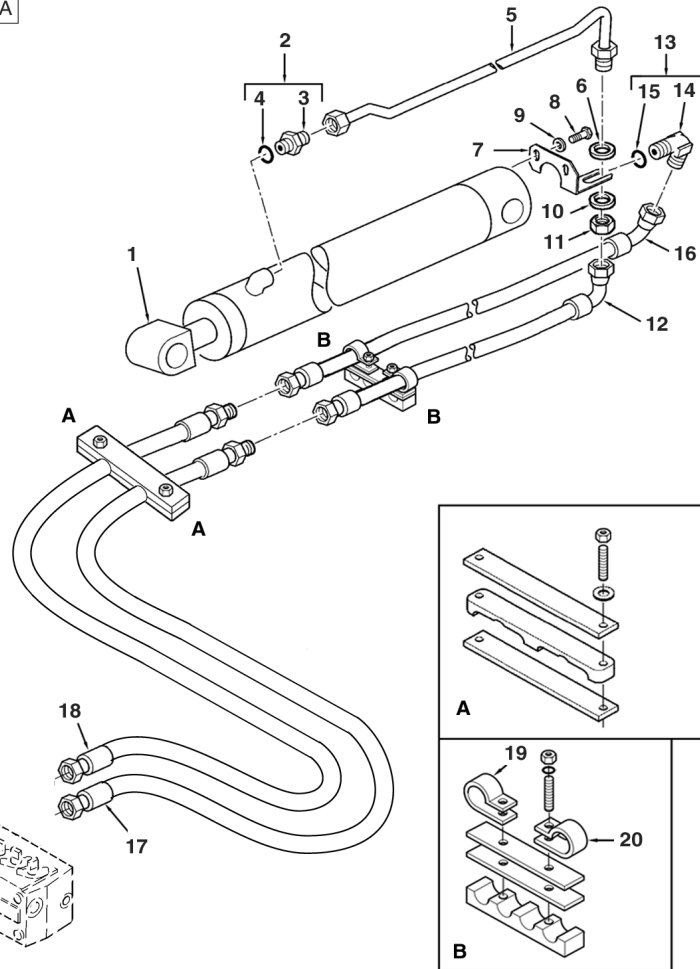

1	5000122M91	76046C06.1 1 4.5m Boom	1	Cylinder Assy	Ensemble de vérin	Gato, Conj.
2	835013M91		1	Connector Assy	Ensemble connexion	Conexión, Conj.
3		Ref. 2	1	Union	Union	Unión
4	835024M1		1	O-Ring	Joint torique	Junta de tipo O
5		(A,B)	1	Tube Assy	Tuyauterie	Conjunto de tubería
6		(A,B)	1	Washer	Rondelle	Arandela
7		(A,B)	1	Bracket	Patte de fixation	Pata de fijación
8	339228X1	M8 x 12	2	Screw	Vis	Tornillo
9	339374X1	M8	2	Washer, Lock	Rondelle de blocage	Arandela de freno
10		(A,B)	1	Washer	Rondelle	Arandela
11		(A,B)	1	Nut	Écrou	Tuerca
12		(A,B)Orange	1	Hose Assy	Ensemble de flexible	Flexible, Conj.
13		(A,B)	1	Elbow	Coude	Codo
14		(A,B) Ref. 13	1	Elbow	Coude	Codo
15		13 (A,B)	1	O-Ring	Joint torique	Junta de tipo O
16	6101736M92	Blue	1	Hose Assy	Ensemble de flexible	Flexible, Conj.
17	6102943M91	Orange	1	Hose Assy	Ensemble de flexible	Flexible, Conj.
18	6102940M91	Blue	1	Hose Assy	Ensemble de flexible	Flexible, Conj.
19	515-23270		1	Clip	Clip	Clip
20	515-23206		1	Clip	Clip	Clip

A Without Hose Burst
 Sans éclatement de tuyau
 Sin rotura de tubo flexible

B See hose burst section
 Voir la section éclatement de tuyau
 Ver la sección de rotura de tubo flexible



860 880 970
 TX860B

813 814 821 822 841 842 851 852 922

76046C05.1

6199042M3

1

Jan-06

Digger Hydraulics
Circuit Hydraulique Défonceuse
Circuito hidráulico equipo retro

Centremount
Montage de Pelle Central
Excavadora de montaje central

Boom Cylinder
Vérin de Flèche
Gato de pluma

High Spec.
High Spec.
High Spec.

C-76046-06.1-A

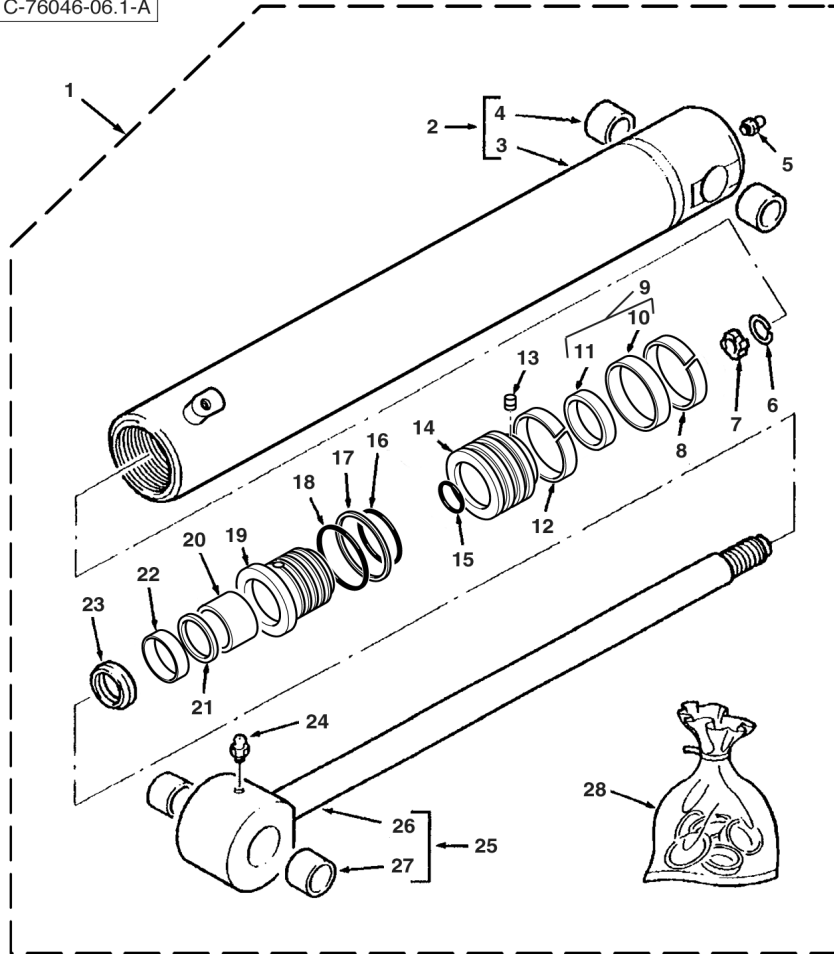

1	5000122M91	76046C05.1 1 4.5m Boom	1	Cylinder Assy	Ensemble de vérin	Gato, Conj.
2	5003912M91	1	1	Cylinder	Cylindre	Cilindro
3		2 Ref. 2	1	Tube, Cylinder	Cylindre de vérin	Cilindro de gato
4		2 (C)	2	Bushing	Bague	Anillo
5	339608X1	1	1	Fitting, Grease	Graisser	Engrasador
6	1609899M1	1	1	Ring, Snap	Anneau d'arrêt	Anillo de resorte
7	1609328M1	1	1	Ring	Anneau	Aro
8	3403852M1	1 (A)	1	Ring	Anneau	Aro
9	3485213M91	1 (A)	1	Seal Assy	Ensemble de joint	Junta, Conj.
10		9 Ref. 9	1	Seal	Joint	Junta
11		9 Ref. 9	1	Seal	Joint	Junta
12	3403852M1	1	1	Ring	Anneau	Aro
13	3402928M1	1	1	Screw	Vis	Tornillo
14	3484189M1	1	1	Piston	Piston	Pistón
15	3007182X1	1 (A)	1	O-Ring	Joint torique	Junta de tipo O
16	359203X1	1 (A)	1	O-Ring	Joint torique	Junta de tipo O
17	367120X1	1 (A)	1	Ring	Anneau	Aro
18	3487909M1	1 (A)	1	O-Ring	Joint torique	Junta de tipo O
19	3623202M1	1	1	Bearing	Coussinet	Cojinete
20	3623193M1	1 (A)	1	Ring	Anneau	Aro
21	3443388M1	1 (A)	1	Ring	Anneau	Aro
22	3443472M1	1 (A)	1	Seal	Joint	Junta
23	3403385M1	1 (A)	1	Ring, Wiper	Joint de racleur	Junta raspador
24	339608X1	1	1	Fitting, Grease	Graisser	Engrasador
25	3441629M91	1	1	Rod, Piston	Tige de vérin	Vástago cilindro
26		25 Ref. 25	1	Rod, Piston	Tige de vérin	Vástago cilindro
27	3484843M1	25	1	Bush	Bague	Casquillo
28	3623589M91	(B)	1	Kit, Seal	Pochette de joints	Juego de juntas

A Included in kit marked (B)
 Inclus dans jeu marqué (B)
 Incluido en juego marcado (B)

C Part number to be advised
 Référence pièce à demander
 Indicar número de pieza

B Contains items marked (A)
 Comprend les pièces marquées (A)
 Incluye las piezas marcadas (A)



860 880 970
 TX860B

813 814 821 822 841 842 851 852 922

76046C06.1

6199042M3

1

Jan-06

Digger Hydraulics
Circuit Hydraulique Défonceuse
Circuito hidráulico equipo retro

Centremount
Montage de Pelle Central
Excavadora de montaje central

Swing Components
Organes de Rotation
Componentes de rotación

High Spec.
 High Spec.
 High Spec.

C-76046-07.1-A

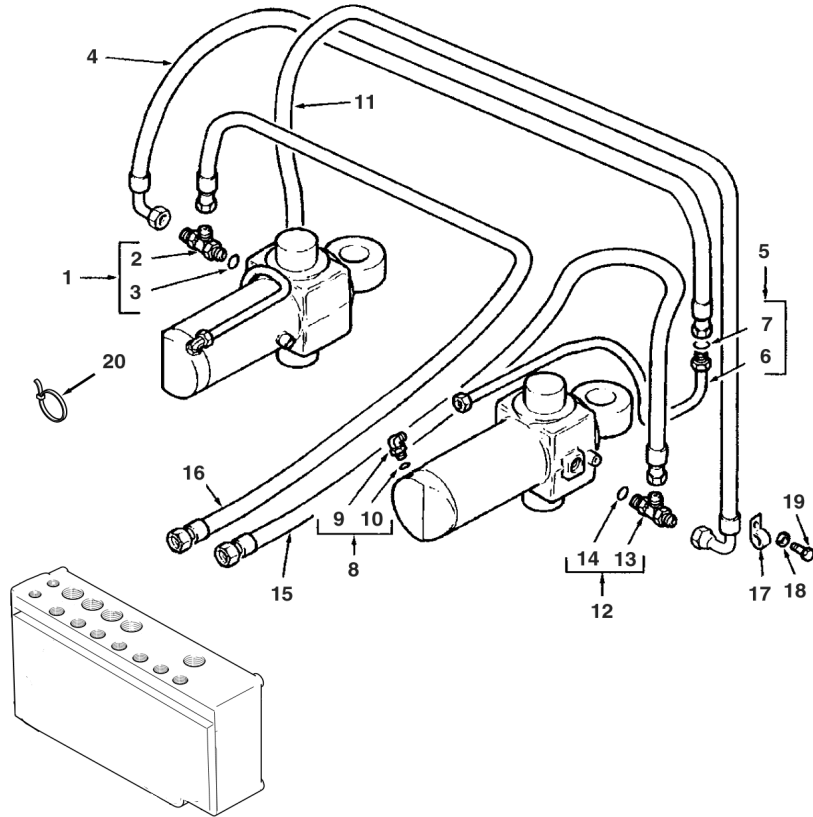

1	358728X91		1	Tee	Raccord en T	Te
2		1	▶ Ref. 1	1	Tee	Raccord en T
3	831497M1	1		1	O-Ring	Joint torique
4	6100716M91	840 mm		1	Hose Assy	Ensemble de flexible
5	6100587M91	▶		1	Tube Assy	Tuyauterie
5	6100589M91	▶		1	Tube Assy	Tuyauterie
6		5	▶ Ref. 5	1	Tube	Tube
7	394923X1	5		1	O-Ring	Joint torique
8	357197X91			2	Elbow, 90°	Coude à 90°
9		8	▶ Ref. 8	1	Elbow	Coude
10	831452M1	8		1	O-Ring	Joint torique
11	6100716M91	840 mm		1	Hose Assy	Ensemble de flexible
12	358728X91			1	Tee	Raccord en T
13		12	▶ Ref. 12	1	Tee	Raccord en T
14	831497M1	12		1	O-Ring	Joint torique
15	6100715M92	Purple 700mm		1	Hose Assy	Ensemble de flexible
16	6101866M93	Green 700mm		1	Hose Assy	Ensemble de flexible
17	3517114M2			2	Clip, Mounting	Collier de fixation
18	385361X1	M8		2	Washer	Rondelle
19	339228X1	M8 x 12		2	Screw	Vis
20	1862425M1			1	Tie, Cable	Attache câble



860 880 970
 TX860B

813 814 821 822 841 842 851 852 922

76046C07.1

6199042M3

1

Jan-06

Digger Hydraulics
Circuit Hydraulique Défonceuse
Circuito hidráulico equipo retro

Centremount
Montage de Pelle Central
Excavadora de montaje central

Bucket
 Godet
 Cuchara

High Spec.
 High Spec.
 High Spec.

C-76047-01.1-A

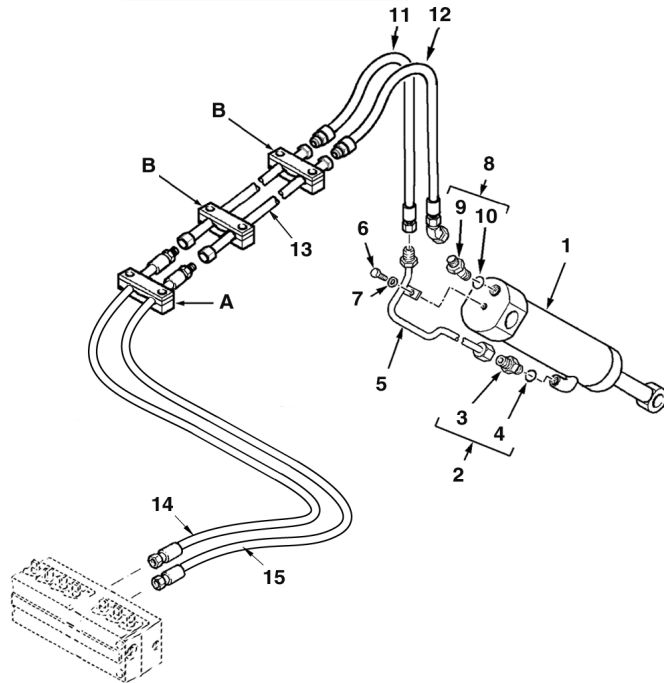
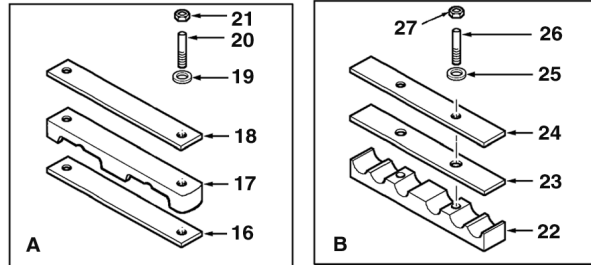

1	5000126M91	76047C02.1 1	1	Cylinder Assy	Ensemble de vérin	Gato, Conj.
2	835013M91		1	Connector Assy	Ensemble connexion	Conexión, Conj.
3		2 Ref. 2	1	Union	Union	Unión
4	835024M1	2	1	O-Ring	Joint torique	Junta de tipo O
5	6101540M91		1	Tube Assy	Tuyauterie	Conjunto de tubería
6	339123X1	M8 x 20	1	Bolt	Boulon	Perno
7	385361X1	M8	1	Washer	Rondelle	Arandela
8	835010M91		1	Elbow, 45°	Coude à 45°	Codo, 45°
9		8 Ref. 8	1	Elbow	Coude	Codo
10	835024M1	8	1	O-Ring	Joint torique	Junta de tipo O
11		(A)Brown	1	Hose Assy	Ensemble de flexible	Flexible, Conj.
12		(A)White	1	Hose Assy	Ensemble de flexible	Flexible, Conj.
13	6101771M91		2	Tube Assy	Tuyauterie	Conjunto de tubería
14	6102945M91	Brown	1	Hose Assy	Ensemble de flexible	Flexible, Conj.
15	6102942M91	White	1	Hose Assy	Ensemble de flexible	Flexible, Conj.
16	6102128M1		1	Pad	Plaque antidérapante	Cinta antideslizante
17	6102122M1		1	Bracket, Clamp	Bride de fixation	Brida de fijación
18	6102130M1		1	Plate	Plaque	Placa
19	390972X1	M8	2	Washer	Rondelle	Arandela
20	3516075M1	M8 x 65	2	Stud	Goujon	Espárrago
21	394367X1	M8	2	Nut, Lock	Écrou de blocage	Tuerca de retención
22	6102126M1		2	Bracket, Clamp	Bride de fixation	Brida de fijación
23	6102145M1		2	Pad	Plaque antidérapante	Cinta antideslizante
24	6102124M1		2	Plate	Plaque	Placa
25	390972X1	M8	4	Washer	Rondelle	Arandela
26	6108049M1		4	Stud	Goujon	Espárrago
27	394367X1	M8	4	Nut, Lock	Écrou de blocage	Tuerca de retención

A See extendahoe hydraulics section
 Voir la section circuit hydraulique extendahoe
 Ver la sección de la circuito hidráulico extendahoe



860 880 970
 TX860B

813 814 821 822 841 842 851 852 922

76047C01.1

6199042M3

1

Jan-06

Digger Hydraulics
Circuit Hydraulique Défonceuse
Circuito hidráulico equipo retro

Centremount
Montage de Pelle Central
Excavadora de montaje central

Bucket Cylinder
Vérin de Godet
Gato de cuchara

High Spec.
 High Spec.
 High Spec.

C-76047-02.1-A

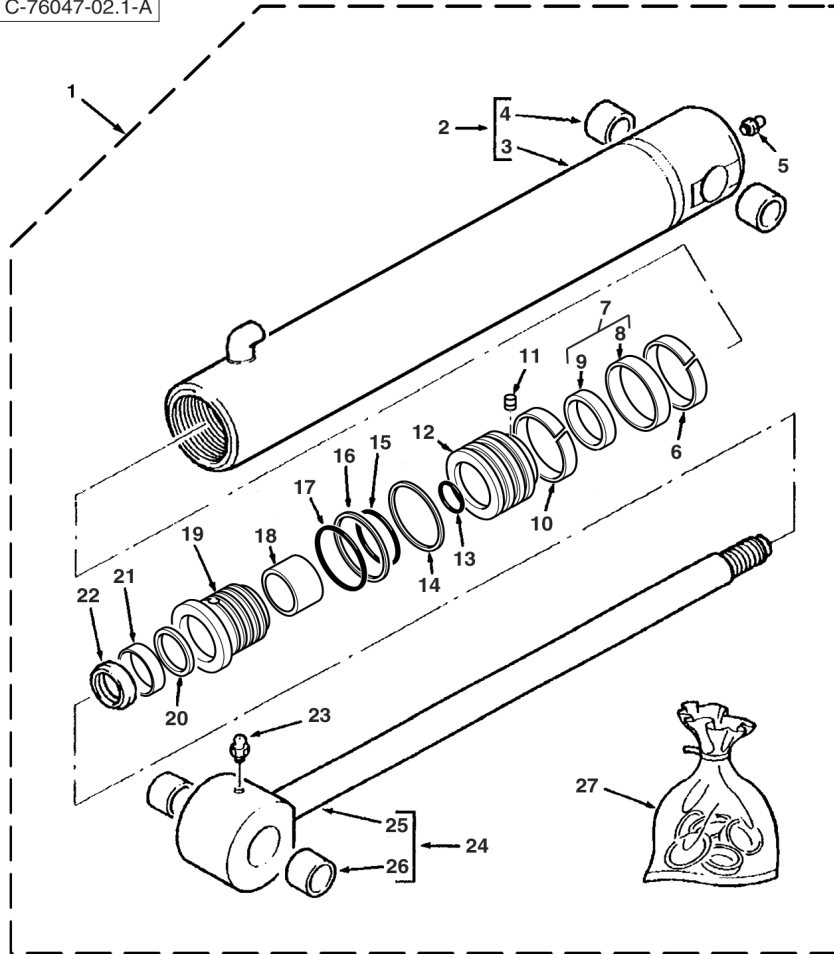

1	5000126M91		76047C01.1 1	1	Cylinder Assy	Ensemble de vérin	Gato, Conj.
2	5004008M91	1		1	Cylinder	Cylindre	Cilindro
3		3	Ref. 2	1	Tube, Cylinder	Cylindre de vérin	Cilindro de gato
4		3 (C)		1	Bushing	Bague	Anillo
5	339608X1	1		1	Fitting, Grease	Graisneur	Engrasador
6	3485892M1	1 (A)		1	Ring, Sealing	Bague d'étanchéité	Anillo, Estanqueidad
7	3485245M91	1 (A)		1	Seal Assy	Ensemble de joint	Junta, Conj.
8		7	Ref. 7	1	Seal	Joint	Junta
9		7	Ref. 7	1	Ring	Anneau	Aro
10	3485892M1	1 (A)		1	Ring, Sealing	Bague d'étanchéité	Anillo, Estanqueidad
11	3402928M1	1		1	Screw	Vis	Tornillo
12	3623372M1	1		1	Piston	Piston	Pistón
13	359186X1	1 (A)		1	O-Ring	Joint torique	Junta de tipo O
14	3623061M1	1		1	Ring, Piston	Segment de piston	Segmento de pistón
15	359193X1	1 (A)		1	O-Ring	Joint torique	Junta de tipo O
16	1606735M1	1 (A)		1	Ring, Backup	Contre-joint	ContraJunta
17	3487207M1	1 (A)		1	O-Ring	Joint torique	Junta de tipo O
18	3484615M1	1 (A)		1	Ring	Anneau	Aro
19	3623371M1	1		1	Bearing	Coussinet	Cojinete
20	3484055M1	1 (A)		1	Ring	Anneau	Aro
21	3485185M1	1 (A)		1	Seal	Joint	Junta
22	3487015M1	1 (A)		1	Ring	Anneau	Aro
23	339608X1	1		1	Fitting, Grease	Graisneur	Engrasador
24	5004012M91	1		1	Rod, Piston	Tige de vérin	Vástago cilindro
25		24	Ref. 24	1	Rod, Piston	Tige de vérin	Vástago cilindro
26		24 (C)		1	Bushing	Bague	Anillo
27	3623373M91		(B)	1	Kit, Seal	Pochette de joints	Juego de juntas

A Contains items marked (A)
 Comprend les pièces marquées (A)
 Incluye las piezas marcadas (A)
 C Part number to be advised
 Référence pièce à demander
 Indicar número de pieza

B Included in kit marked (B)
 Inclus dans jeu marqué (B)
 Incluido en juego marcado (B)



860 880 970
 TX860B

813 814 821 822 841 842 851 852 922

76047C02.1

6199042M3

1

Jan-06

Digger Hydraulics
Circuit Hydraulique Défonceuse
Circuito hidráulico equipo retro

Centremount
Montage de Pelle Central
Excavadora de montaje central

Telescopic Dipper
Balancier Téléscopique
Balancín telescópico

High Spec.
 High Spec.
 High Spec.

C-76047-03.1-A

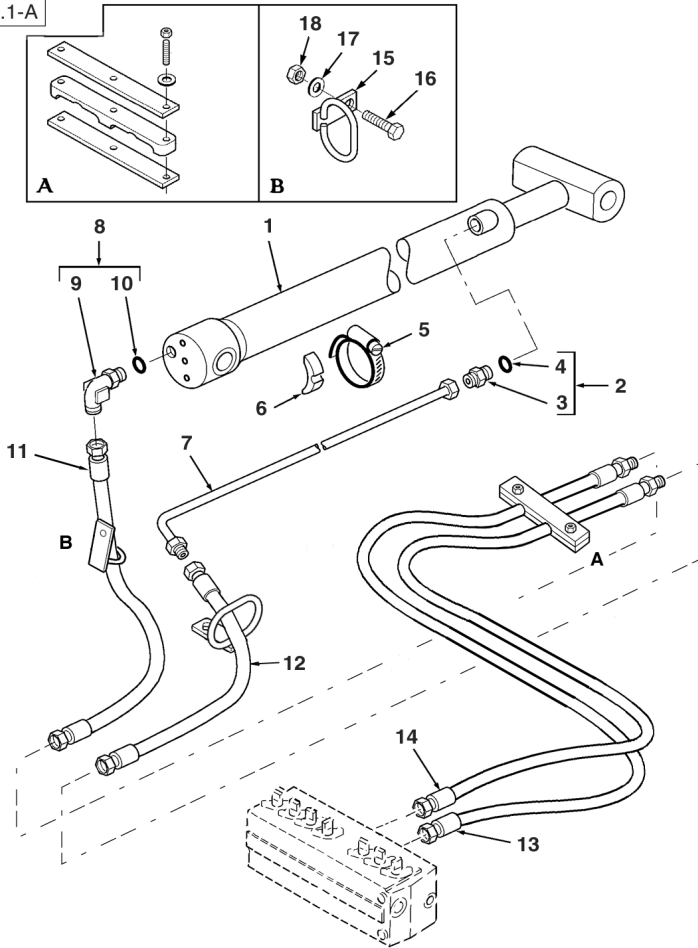

1	5000124M91	76047C04.1 1	1	Cylinder Assy	Ensemble de vérin	Gato, Conj.
2	835013M91		1	Connector Assy	Ensemble connexion	Conexión, Conj.
3		2 Ref. 2	1	Union	Union	Unión
4	835024M1	2	1	O-Ring	Joint torique	Junta de tipo O
5	3517733M1		1	Clamp	Collier de serrage	Argolla de cierre
6	L79937		1	Spacer	Entretoise	Travesa
7		(A,B)	1	Tube Assy	Tuyauterie	Conjunto de tubería
8		(A,B)	1	Elbow	Coude	Codo
9		8 (A,B) Ref. 8	1	Elbow	Coude	Codo
10		8 (A,B)	1	O-Ring	Joint torique	Junta de tipo O
11	6101738M91	Yellow	1	Hose Assy	Ensemble de flexible	Flexible, Conj.
12	6101737M91	Red	1	Hose Assy	Ensemble de flexible	Flexible, Conj.
13	6102941M91	Yellow	1	Hose Assy	Ensemble de flexible	Flexible, Conj.
14	6102944M91	Red	1	Hose Assy	Ensemble de flexible	Flexible, Conj.
15	6101491M92		2	Support Assy	Ensemble de support	Apoyadero, Conj.
16	339761X1	M8 x 25	2	Screw	Vis	Tornillo
17	390972X1	M8	2	Washer	Rondelle	Arandela
18	394367X1	M8	2	Nut, Lock	Écrou de blocage	Tuerca de retención

A Without Hose Burst
 Sans éclatement de tuyau
 Sin rotura de tubo flexible

B See hose burst section
 Voir la section éclatement de tuyau
 Ver la sección de rotura de tubo flexible



860 880 970
 TX860B

813 814 821 822 841 842 851 852 922

76047C03.1

6199042M3

1

Jan-06

Digger Hydraulics
Circuit Hydraulique Défonceuse
Circuito hidráulico equipo retro

Centremount
Montage de Pelle Central
Excavadora de montaje central

Dipper Cylinder
Vérin de Balancier
Gato de balancín

High Spec.
High Spec.
High Spec.

C-76047-04.1-A

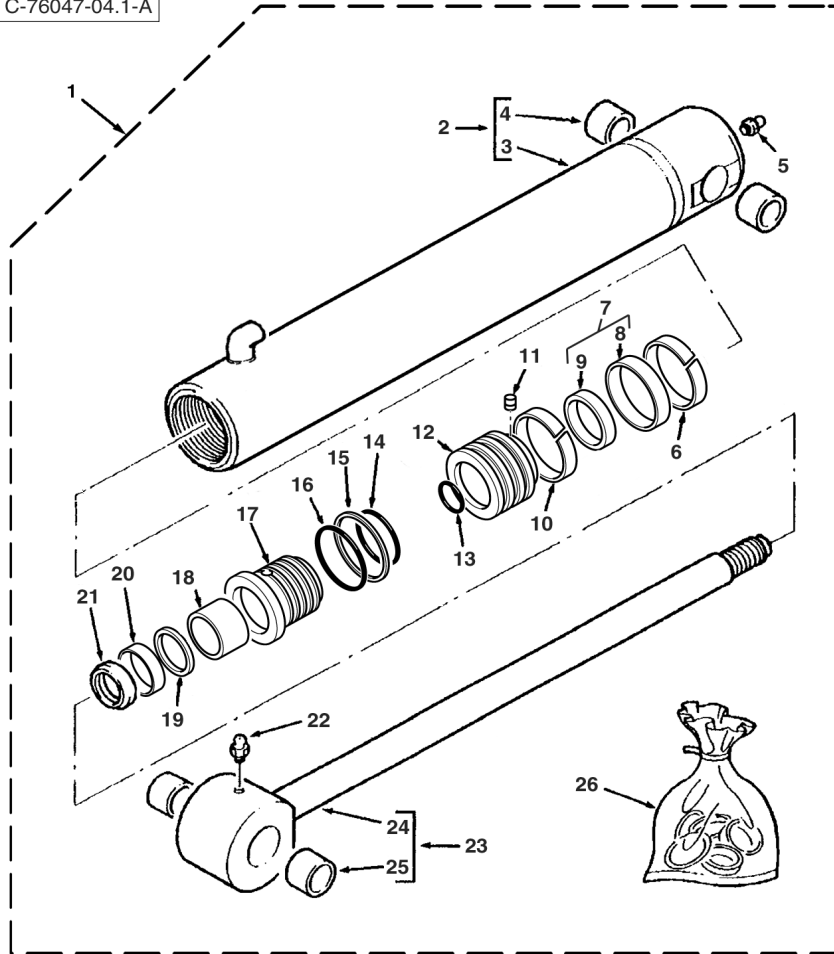

1	5000124M91		76047C03.1 1	1	Cylinder Assy	Ensemble de vérin	Gato, Conj.
2	5003982M91	1		1	Cylinder	Cylindre	Cilindro
3		2	Ref. 2	1	Tube, Cylinder	Cylindre de vérin	Cilindro de gato
4	3484843M1	2		1	Bush	Bague	Casquillo
5	339608X1	1		1	Fitting, Grease	Graisneur	Engrasador
6	3485891M1	1 (A)		1	Ring	Anneau	Aro
7	3485247M91	1 (A)		1	Seal Assy	Ensemble de joint	Junta, Conj.
8		7	Ref. 7	1	Seal	Joint	Junta
9		7	Ref. 7	1	Ring	Anneau	Aro
10	3485891M1	1 (A)		1	Ring	Anneau	Aro
11	3402928M1	1		1	Screw	Vis	Tornillo
12	5003989M1	1		1	Piston	Piston	Pistón
13	3007182X1	1 (A)		1	O-Ring	Joint torique	Junta de tipo O
14	359196X1	1 (A)		1	O-Ring	Joint torique	Junta de tipo O
15	378545X1	1 (A)		1	Ring	Anneau	Aro
16	3487908M1	1 (A)		1	O-Ring	Joint torique	Junta de tipo O
17	5003988M1	1		1	Bearing	Coussinet	Cojinete
18	3623193M1	1 (A)		1	Ring	Anneau	Aro
19	3443388M1	1 (A)		1	Ring	Anneau	Aro
20	3443472M1	1 (A)		1	Seal	Joint	Junta
21	3403385M1	1 (A)		1	Ring, Wiper	Joint de racleur	Junta raspador
22	339608X1	1		1	Fitting, Grease	Graisneur	Engrasador
23	5003985M91	1		1	Rod, Piston	Tige de vérin	Vástago cilindro
24		23	Ref. 23	1	Rod, Piston	Tige de vérin	Vástago cilindro
25	3484843M1	23		1	Bush	Bague	Casquillo
26	5004401M91		(B)	1	Kit, Seal	Pochette de joints	Juego de juntas

A Included in kit marked (B)
Inclus dans jeu marqué (B)
Incluido en juego marcado (B)

B Contains items marked (A)
Comprend les pièces marquées (A)
Incluye las piezas marcadas (A)



860 880 970
TX860B

813 814 821 822 841 842 851 852 922

76047C04.1

6199042M3

1

Jan-06

Digger Hydraulics
Circuit Hydraulique Défonceuse
Circuito hidráulico equipo retro

Centremount
Montage de Pelle Central
Excavadora de montaje central

Boom 4.5m
 Flèche 4.5m
 Pluma 4.5m

High Spec.
 High Spec.
 High Spec.

C-76047-05.1-A

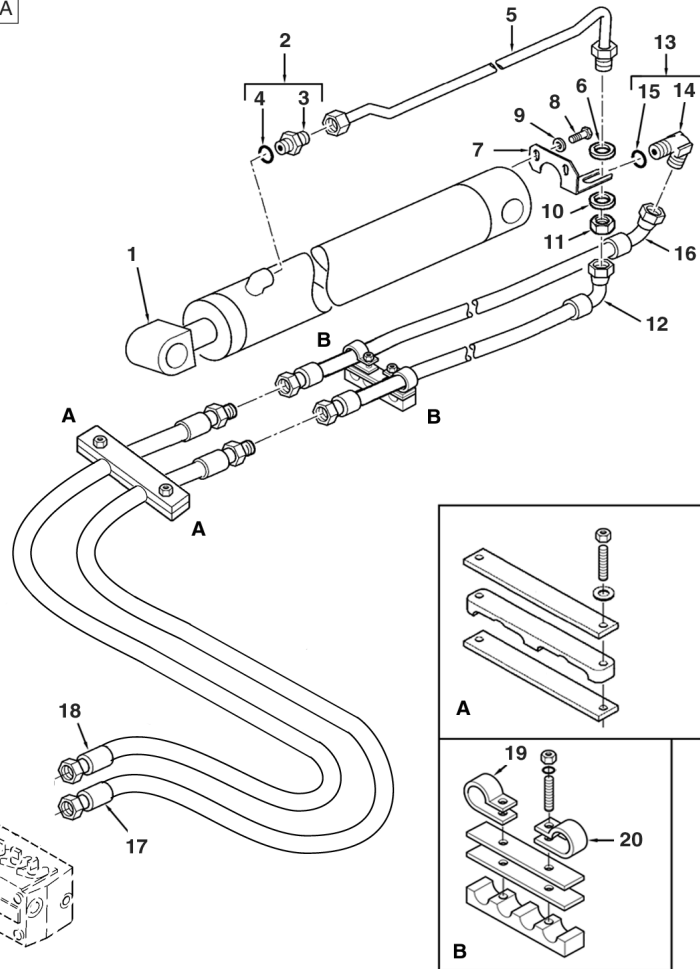

1	5000122M91	76047C06.1 1 4.5m Boom	1	Cylinder Assy	Ensemble de vérin	Gato, Conj.
2	835013M91		1	Connector Assy	Ensemble connexion	Conexión, Conj.
3		Ref. 2	1	Union	Union	Unión
4	835024M1		1	O-Ring	Joint torique	Junta de tipo O
5		(A,B)	1	Tube Assy	Tuyauterie	Conjunto de tubería
6		(A,B)	1	Washer	Rondelle	Arandela
7		(A,B)	1	Bracket	Patte de fixation	Pata de fijación
8	339228X1	M8 x 12	2	Screw	Vis	Tornillo
9	339374X1	M8	2	Washer, Lock	Rondelle de blocage	Arandela de freno
10		(A,B)	1	Washer	Rondelle	Arandela
11		(A,B)	1	Nut	Écrou	Tuerca
12		(A,B)Orange	1	Hose Assy	Ensemble de flexible	Flexible, Conj.
13		(A,B)	1	Elbow	Coude	Codo
14		(A,B)	1	Elbow	Coude	Codo
15		Ref. 13	1	O-Ring	Joint torique	Junta de tipo O
16	6101736M92	Blue	1	Hose Assy	Ensemble de flexible	Flexible, Conj.
17	6102943M91	Orange	1	Hose Assy	Ensemble de flexible	Flexible, Conj.
18	6102940M91	Blue	1	Hose Assy	Ensemble de flexible	Flexible, Conj.
19	515-23270		1	Clip	Clip	Clip
20	515-23206		1	Clip	Clip	Clip

A Without Hose Burst
 Sans éclatement de tuyau
 Sin rotura de tubo flexible

B See hose burst section
 Voir la section éclatement de tuyau
 Ver la sección de rotura de tubo flexible



860 880 970
 TX860B

813 814 821 822 841 842 851 852 922

76047C05.1

6199042M3

1

Jan-06

Digger Hydraulics
Circuit Hydraulique Défonceuse
Circuito hidráulico equipo retro

Centremount
Montage de Pelle Central
Excavadora de montaje central

Boom Cylinder
Vérin de Flèche
Gato de pluma

High Spec.
High Spec.
High Spec.

C-76047-06.1-A

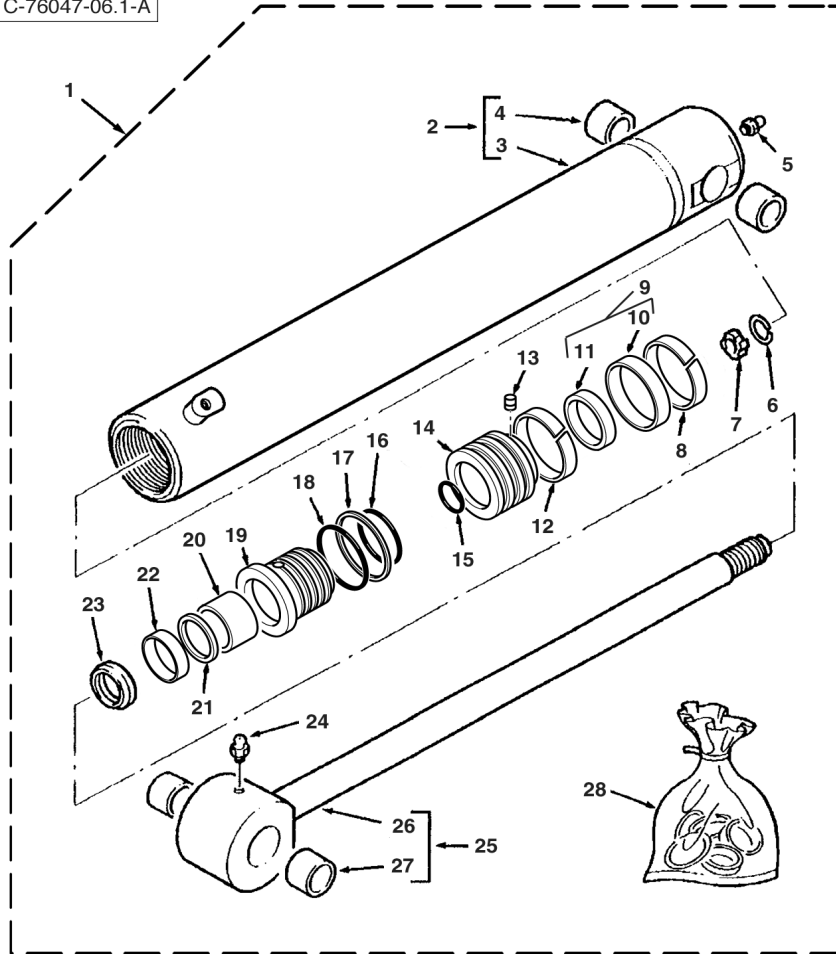

1	5000122M91	76047C05.1 1 4.5m Boom	1	Cylinder Assy	Ensemble de vérin	Gato, Conj.
2	5003912M91	1	1	Cylinder	Cylindre	Cilindro
3		2 Ref. 2	1	Tube, Cylinder	Cylindre de vérin	Cilindro de gato
4		2 (C)	2	Bushing	Bague	Anillo
5	339608X1	1	1	Fitting, Grease	Graisser	Engrasador
6	1609899M1	1	1	Ring, Snap	Anneau d'arrêt	Anillo de resorte
7	1609328M1	1	1	Ring	Anneau	Aro
8	3403852M1	1 (A)	1	Ring	Anneau	Aro
9	3485213M91	1 (A)	1	Seal Assy	Ensemble de joint	Junta, Conj.
10		9 Ref. 9	1	Seal	Joint	Junta
11		9 Ref. 9	1	Seal	Joint	Junta
12	3403852M1	1	1	Ring	Anneau	Aro
13	3402928M1	1	1	Screw	Vis	Tornillo
14	3484189M1	1	1	Piston	Piston	Pistón
15	3007182X1	1 (A)	1	O-Ring	Joint torique	Junta de tipo O
16	359203X1	1 (A)	1	O-Ring	Joint torique	Junta de tipo O
17	367120X1	1 (A)	1	Ring	Anneau	Aro
18	3487909M1	1 (A)	1	O-Ring	Joint torique	Junta de tipo O
19	3623202M1	1	1	Bearing	Coussinet	Cojinete
20	3623193M1	1 (A)	1	Ring	Anneau	Aro
21	3443388M1	1 (A)	1	Ring	Anneau	Aro
22	3443472M1	1 (A)	1	Seal	Joint	Junta
23	3403385M1	1 (A)	1	Ring, Wiper	Joint de racleur	Junta raspador
24	339608X1	1	1	Fitting, Grease	Graisser	Engrasador
25	3441629M91	1	1	Rod, Piston	Tige de vérin	Vástago cilindro
26		25 Ref. 25	1	Rod, Piston	Tige de vérin	Vástago cilindro
27	3484843M1	25	1	Bush	Bague	Casquillo
28	3623589M91	(B)	1	Kit, Seal	Pochette de joints	Juego de juntas

A Included in kit marked (B)
 Inclus dans jeu marqué (B)
 Incluido en juego marcado (B)

C Part number to be advised
 Référence pièce à demander
 Indicar número de pieza

B Contains items marked (A)
 Comprend les pièces marquées (A)
 Incluye las piezas marcadas (A)



860 880 970
 TX860B

813 814 821 822 841 842 851 852 922

76047C06.1

6199042M3

1

Jan-06

Digger Hydraulics
Circuit Hydraulique Défonceuse
Circuito hidráulico equipo retro

Centremount
Montage de Pelle Central
Excavadora de montaje central

Swing Components
Organes de Rotation
Componentes de rotación

High Spec.
 High Spec.
 High Spec.

C-76047-07.1-A

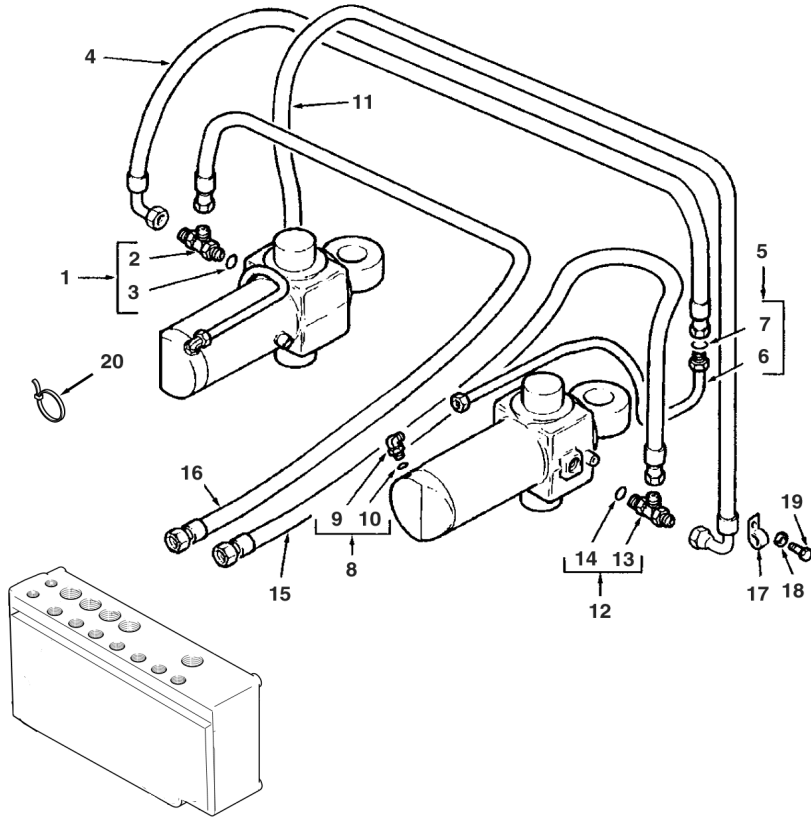

1	358728X91			1	Tee	Raccord en T	Te
2		1	▶ Ref. 1	1	Tee	Raccord en T	Te
3	831497M1	1		1	O-Ring	Joint torique	Junta de tipo O
4	6100716M91	840 mm		1	Hose Assy	Ensemble de flexible	Flexible, Conj.
5	6100587M91		◀	1	Tube Assy	Tuyauterie	Conjunto de tubería
5	6100589M91		▶	1	Tube Assy	Tuyauterie	Conjunto de tubería
6		5	▶ Ref. 5	1	Tube	Tube	Tubo
7	394923X1	5		1	O-Ring	Joint torique	Junta de tipo O
8	357197X91			2	Elbow, 90°	Coude à 90°	Codo, 90°
9		8	▶ Ref. 8	1	Elbow	Coude	Codo
10	831452M1	8		1	O-Ring	Joint torique	Junta de tipo O
11	6100716M91	840 mm		1	Hose Assy	Ensemble de flexible	Flexible, Conj.
12	358728X91			1	Tee	Raccord en T	Te
13		12	▶ Ref. 12	1	Tee	Raccord en T	Te
14	831497M1	12		1	O-Ring	Joint torique	Junta de tipo O
15	6100715M92	Purple 700mm		1	Hose Assy	Ensemble de flexible	Flexible, Conj.
16	6101866M93	Green 700mm		1	Hose Assy	Ensemble de flexible	Flexible, Conj.
17	3517114M2			2	Clip, Mounting	Collier de fixation	Argolla de fijación
18	385361X1	M8		2	Washer	Rondelle	Arandela
19	339228X1	M8 x 12		2	Screw	Vis	Tornillo
20	1862425M1			1	Tie, Cable	Attache câble	Enlace de Cable



860 880 970
 TX860B

813 814 821 822 841 842 851 852 922

76047C07.1

6199042M3

1

Jan-06

Digger Hydraulics
Circuit Hydraulique Défonceuse
Circuito hidráulico equipo retro

Centremount
Montage de Pelle Central
Excavadora de montaje central

Bucket
 Godet
 Cuchara

4.9m
 4.9m
 4.9m

C-76048-01.1-A

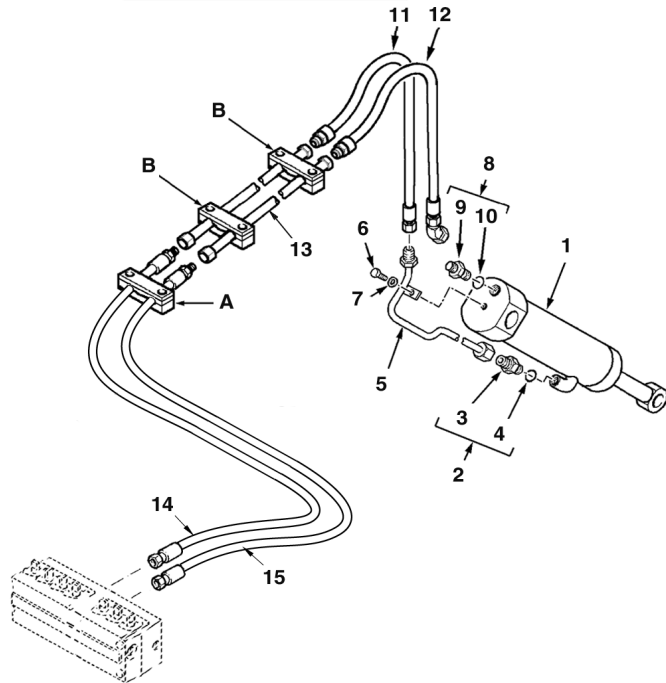
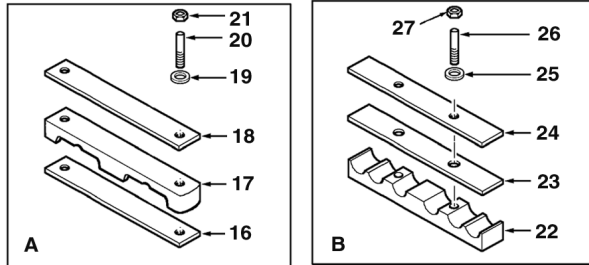

1	5000126M91	76048C02.1 1	1	Cylinder Assy	Ensemble de vérin	Gato, Conj.
2	835013M91		1	Connector Assy	Ensemble connexion	Conexión, Conj.
3		2 Ref. 2	1	Union	Union	Unión
4	835024M1	2	1	O-Ring	Joint torique	Junta de tipo O
5	6101540M91		1	Tube Assy	Tuyauterie	Conjunto de tubería
6	339123X1	M8 x 20	1	Bolt	Boulon	Perno
7	385361X1	M8	1	Washer	Rondelle	Arandela
8	835013M91		1	Connector Assy	Ensemble connexion	Conexión, Conj.
9		8 Ref. 8	1	Union	Union	Unión
10	835024M1	8	1	O-Ring	Joint torique	Junta de tipo O
11	6102309M91	Brown	1	Hose Assy	Ensemble de flexible	Flexible, Conj.
12	6107024M91	White	1	Hose Assy	Ensemble de flexible	Flexible, Conj.
13	6101431M91		2	Tube Assy	Tuyauterie	Conjunto de tubería
14	6102945M91	Brown	1	Hose Assy	Ensemble de flexible	Flexible, Conj.
15	6102942M91	White	1	Hose Assy	Ensemble de flexible	Flexible, Conj.
16	6102128M1		1	Pad	Plaque antidérapante	Cinta antideslizante
17	6102122M1		1	Bracket, Clamp	Bride de fixation	Brida de fijación
18	6102130M1		1	Plate	Plaque	Placa
19	390972X1	M8	2	Washer	Rondelle	Arandela
20	3516075M1	M8 x 65	2	Stud	Goujon	Espárrago
21	394367X1	M8	2	Nut, Lock	Écrou de blocage	Tuerca de retención
22	6102126M1		2	Bracket, Clamp	Bride de fixation	Brida de fijación
23	6102145M1		2	Pad	Plaque antidérapante	Cinta antideslizante
24	6102124M1		2	Plate	Plaque	Placa
25	390972X1	M8	4	Washer	Rondelle	Arandela
26	6108049M1		4	Stud	Goujon	Espárrago
27	394367X1	M8	4	Nut, Lock	Écrou de blocage	Tuerca de retención



860 880 970 980
 TX870B TX970B

815 816 823 824 843 844 853 854 923 932

76048C01.1

6199042M3

1

Jan-06

Digger Hydraulics
Circuit Hydraulique Défonceuse
Circuito hidráulico equipo retro

Centremount
Montage de Pelle Central
Excavadora de montaje central

Bucket Cylinder
Vérin de Godet
Gato de cuchara

4.9m
 4.9m
 4.9m

C-76048-02.1-A

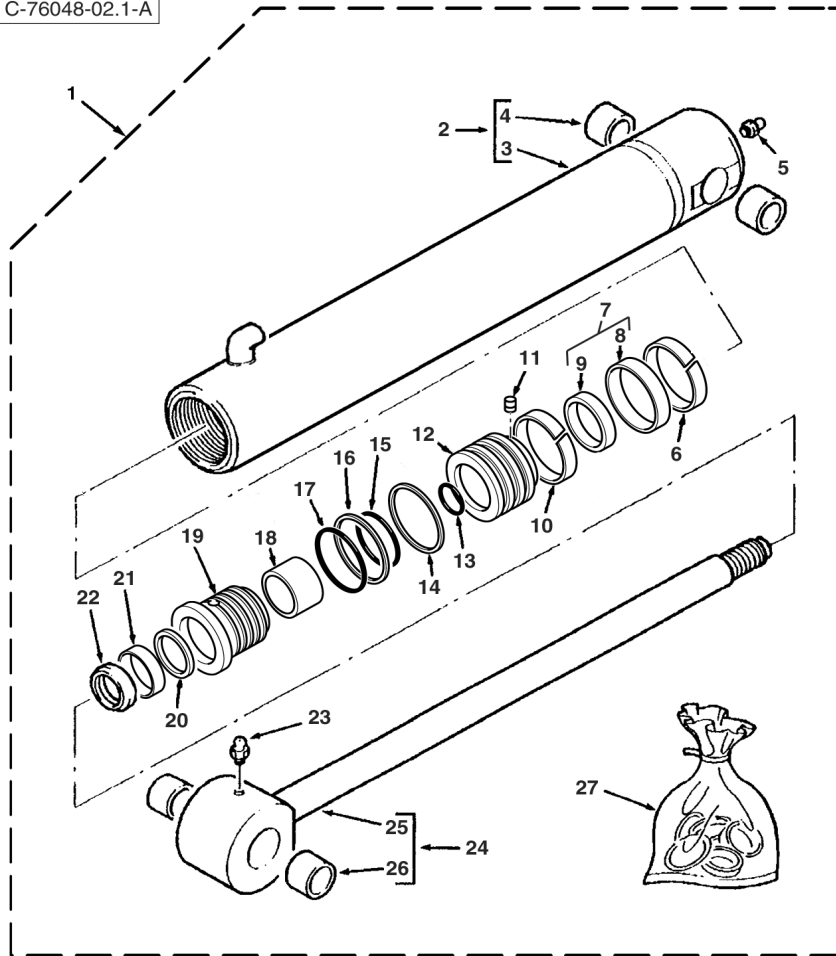

1	5000126M91		76048C01.1 1	1	Cylinder Assy	Ensemble de vérin	Gato, Conj.
2	5004008M91	1		1	Cylinder	Cylindre	Cilindro
3		3	Ref. 2	1	Tube, Cylinder	Cylindre de vérin	Cilindro de gato
4		3 (C)		1	Bushing	Bague	Anillo
5	339608X1	1		1	Fitting, Grease	Graisneur	Engrasador
6	3485892M1	1 (A)		1	Ring, Sealing	Bague d'étanchéité	Anillo, Estanqueidad
7	3485245M91	1 (A)		1	Seal Assy	Ensemble de joint	Junta, Conj.
8		7	Ref. 7	1	Seal	Joint	Junta
9		7	Ref. 7	1	Ring	Anneau	Aro
10	3485892M1	1 (A)		1	Ring, Sealing	Bague d'étanchéité	Anillo, Estanqueidad
11	3402928M1	1		1	Screw	Vis	Tornillo
12	3623372M1	1		1	Piston	Piston	Pistón
13	359186X1	1 (A)		1	O-Ring	Joint torique	Junta de tipo O
14	3623061M1	1		1	Ring, Piston	Segment de piston	Segmento de pistón
15	359193X1	1 (A)		1	O-Ring	Joint torique	Junta de tipo O
16	1606735M1	1 (A)		1	Ring, Backup	Contre-joint	ContraJunta
17	3487207M1	1 (A)		1	O-Ring	Joint torique	Junta de tipo O
18	3484615M1	1 (A)		1	Ring	Anneau	Aro
19	3623371M1	1		1	Bearing	Coussinet	Cojinete
20	3484055M1	1 (A)		1	Ring	Anneau	Aro
21	3485185M1	1 (A)		1	Seal	Joint	Junta
22	3487015M1	1 (A)		1	Ring	Anneau	Aro
23	339608X1	1		1	Fitting, Grease	Graisneur	Engrasador
24	5004012M91	1		1	Rod, Piston	Tige de vérin	Vástago cilindro
25		24	Ref. 24	1	Rod, Piston	Tige de vérin	Vástago cilindro
26		24 (C)		1	Bushing	Bague	Anillo
27	3623373M91		(B)	1	Kit, Seal	Pochette de joints	Juego de juntas

- A Contains items marked (A)
 Comprend les pièces marquées (A)
 Incluye las piezas marcadas (A)
- C Part number to be advised
 Référence pièce à demander
 Indicar número de pieza

- B Included in kit marked (B)
 Inclus dans jeu marqué (B)
 Incluido en juego marcado (B)



860 880 970 980
 TX870B TX970B

815 816 823 824 843 844 853 854 923 932

76048C02.1

6199042M3

1

Jan-06

Digger Hydraulics
Circuit Hydraulique Défonceuse
Circuito hidráulico equipo retro

Centremount
Montage de Pelle Central
Excavadora de montaje central

Standard Dipper
Balancier Standard
Balancín estándar

4.9m
 4.9m
 4.9m

C-76048-03.1-A

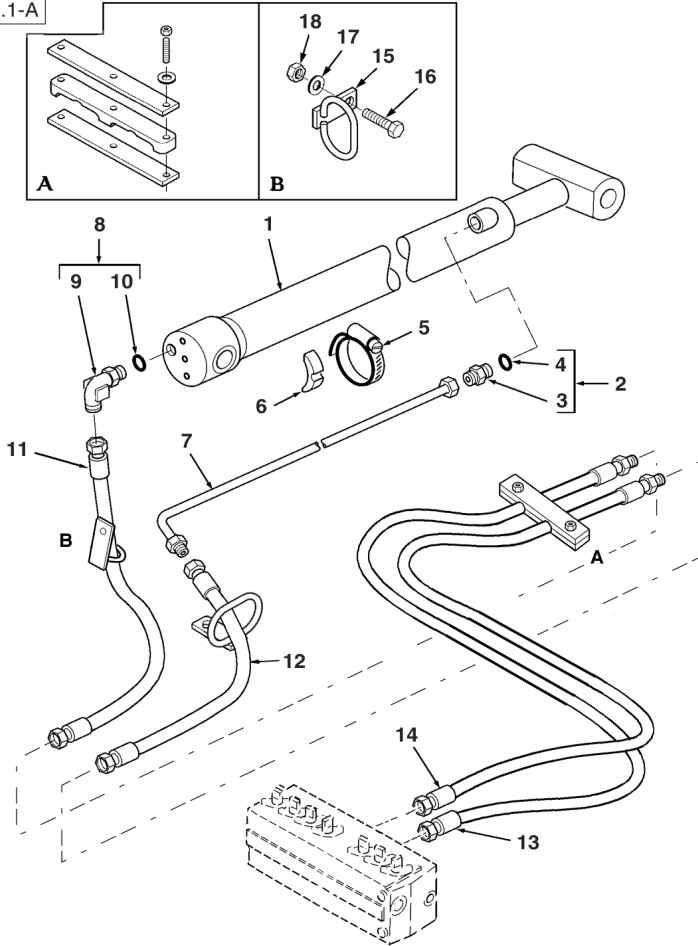

1	5000124M91	76048C04.1 1	1	Cylinder Assy	Ensemble de vérin	Gato, Conj.
2	835013M91		1	Connector Assy	Ensemble connexion	Conexión, Conj.
3		2 Ref. 2	1	Union	Union	Unión
4	835024M1	2	1	O-Ring	Joint torique	Junta de tipo O
5	3517733M1		1	Clamp	Collier de serrage	Argolla de cierre
6	L79937		1	Spacer	Entretoise	Travesa
7		(A,B)	1	Tube Assy	Tuyauterie	Conjunto de tubería
8		(A,B)	1	Elbow	Coude	Codo
9		8 (A,B) Ref. 8	1	Elbow	Coude	Codo
10		8 (A,B)	1	O-Ring	Joint torique	Junta de tipo O
11	6101738M91	Yellow	1	Hose Assy	Ensemble de flexible	Flexible, Conj.
12	6101737M91	Red	1	Hose Assy	Ensemble de flexible	Flexible, Conj.
13	6102941M91	Yellow	1	Hose Assy	Ensemble de flexible	Flexible, Conj.
14	6102944M91	Red	1	Hose Assy	Ensemble de flexible	Flexible, Conj.
15	6101491M92		2	Support Assy	Ensemble de support	Apoyadero, Conj.
16	339761X1	M8 x 25	2	Screw	Vis	Tornillo
17	390972X1	M8	2	Washer	Rondelle	Arandela
18	394367X1	M8	2	Nut, Lock	Écrou de blocage	Tuerca de retención

A Without Hose Burst
 Sans éclatement de tuyau
 Sin rotura de tubo flexible

B See hose burst section
 Voir la section éclatement de tuyau
 Ver la sección de rotura de tubo flexible



860 880 970 980
 TX870B TX970B

815 816 823 824 843 844 853 854 923 932

76048C03.1

6199042M3

1

Jan-06

Digger Hydraulics
Circuit Hydraulique Défonceuse
Circuito hidráulico equipo retro

Centremount
Montage de Pelle Central
Excavadora de montaje central

Dipper Cylinder
Vérin de Balancier
Gato de balancín

4.9m
 4.9m
 4.9m

C-76048-04.1-A

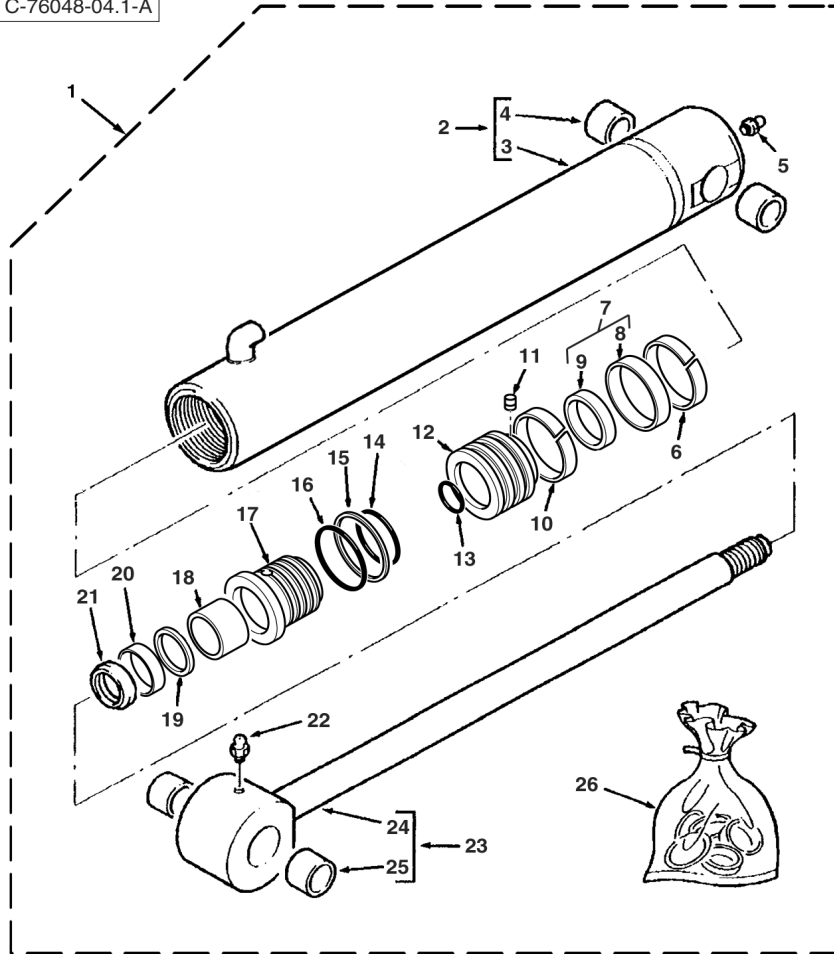

1	5000124M91		76048C03.1 1	1	Cylinder Assy	Ensemble de vérin	Gato, Conj.
2	5003982M91	1		1	Cylinder	Cylindre	Cilindro
3		2	Ref. 2	1	Tube, Cylinder	Cylindre de vérin	Cilindro de gato
4	3484843M1	2		1	Bush	Bague	Casquillo
5	339608X1	1		1	Fitting, Grease	Graisneur	Engrasador
6	3485891M1	1 (A)		1	Ring	Anneau	Aro
7	3485247M91	1 (A)		1	Seal Assy	Ensemble de joint	Junta, Conj.
8		7	Ref. 7	1	Seal	Joint	Junta
9		7	Ref. 7	1	Ring	Anneau	Aro
10	3485891M1	1 (A)		1	Ring	Anneau	Aro
11	3402928M1	1		1	Screw	Vis	Tornillo
12	5003989M1	1		1	Piston	Piston	Pistón
13	3007182X1	1 (A)		1	O-Ring	Joint torique	Junta de tipo O
14	359196X1	1 (A)		1	O-Ring	Joint torique	Junta de tipo O
15	378545X1	1 (A)		1	Ring	Anneau	Aro
16	3487908M1	1 (A)		1	O-Ring	Joint torique	Junta de tipo O
17	5003988M1	1		1	Bearing	Coussinet	Cojinete
18	3623193M1	1 (A)		1	Ring	Anneau	Aro
19	3443388M1	1 (A)		1	Ring	Anneau	Aro
20	3443472M1	1 (A)		1	Seal	Joint	Junta
21	3403385M1	1 (A)		1	Ring, Wiper	Joint de racler	Junta raspador
22	339608X1	1		1	Fitting, Grease	Graisneur	Engrasador
23	5003985M91	1		1	Rod, Piston	Tige de vérin	Vástago cilindro
24		23	Ref. 23	1	Rod, Piston	Tige de vérin	Vástago cilindro
25	3484843M1	23		1	Bush	Bague	Casquillo
26	5004401M91		(B)	1	Kit, Seal	Pochette de joints	Juego de juntas

A Included in kit marked (B)
 Inclus dans jeu marqué (B)
 Incluido en juego marcado (B)

B Contains items marked (A)
 Comprend les pièces marquées (A)
 Incluye las piezas marcadas (A)



860 880 970 980
 TX870B TX970B

815 816 823 824 843 844 853 854 923 932

76048C04.1

6199042M3

1

Jan-06

Digger Hydraulics
Circuit Hydraulique Défonceuse
Circuito hidráulico equipo retro

Centremount
Montage de Pelle Central
Excavadora de montaje central

Boom
 Flèche
 Pluma

4.9m
 4.9m
 4.9m

C-76048-05.1-A

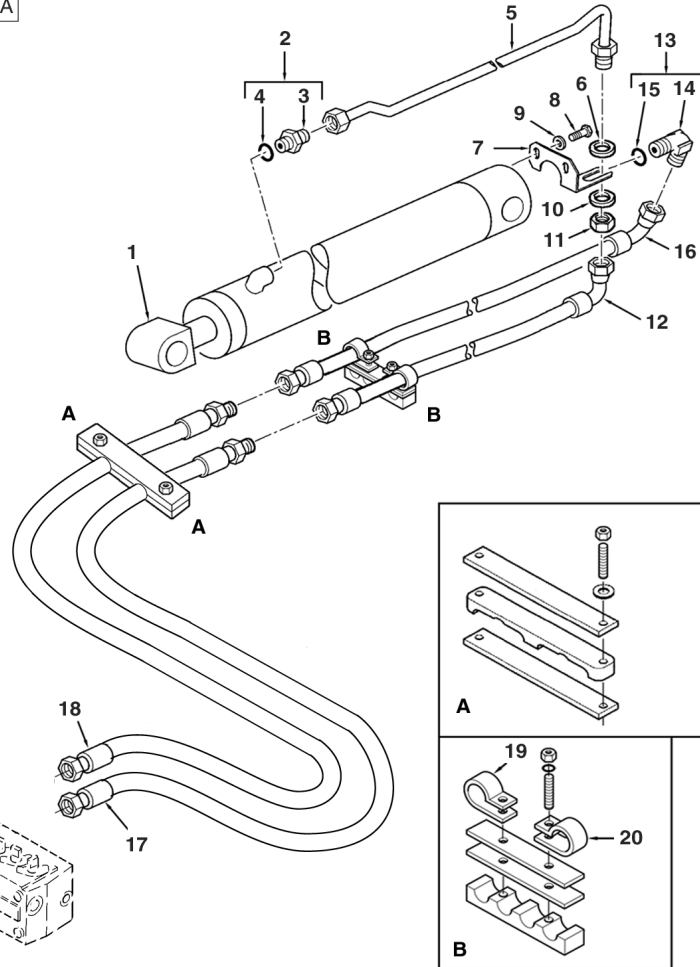

1	5000123M91	76048C06.1 1 4.9m Boom	1	Cylinder Assy	Ensemble de vérin	Gato, Conj.
2	835013M91		1	Connector Assy	Ensemble connexion	Conexión, Conj.
3		Ref. 2	1	Union	Union	Unión
4	835024M1		1	O-Ring	Joint torique	Junta de tipo O
5		(A,B)	1	Tube Assy	Tuyauterie	Conjunto de tubería
6		(A,B)	1	Washer	Rondelle	Arandela
7		(A,B)	1	Bracket	Patte de fixation	Pata de fijación
8	339228X1	M8 x 12	2	Screw	Vis	Tornillo
9	339374X1	M8	2	Washer, Lock	Rondelle de blocage	Arandela de freno
10		(A,B)	1	Washer	Rondelle	Arandela
11		(A,B)	1	Nut	Écrou	Tuerca
12		(A,B)Orange	1	Hose Assy	Ensemble de flexible	Flexible, Conj.
13		(A,B)	1	Elbow	Coude	Codo
14		(A,B) Ref. 13	1	Elbow	Coude	Codo
15		13	1	O-Ring	Joint torique	Junta de tipo O
16	6101736M92	Blue	1	Hose Assy	Ensemble de flexible	Flexible, Conj.
17	6102943M91	Orange	1	Hose Assy	Ensemble de flexible	Flexible, Conj.
18	6102940M91	Blue	1	Hose Assy	Ensemble de flexible	Flexible, Conj.
19	515-23270		1	Clip	Clip	Clip
20	515-23206		1	Clip	Clip	Clip

A Without Hose Burst
 Sans éclatement de tuyau
 Sin rotura de tubo flexible

B See hose burst section
 Voir la section éclatement de tuyau
 Ver la sección de rotura de tubo flexible



860 880 970 980
 TX870B TX970B

815 816 823 824 843 844 853 854 923 932

76048C05.1

6199042M3

1

Jan-06

Digger Hydraulics
Circuit Hydraulique Défonceuse
Circuito hidráulico equipo retro

Centremount
Montage de Pelle Central
Excavadora de montaje central

Boom Cylinder
Vérin de Flèche
Gato de pluma

4.9m
 4.9m
 4.9m

C-76048-06.1-A

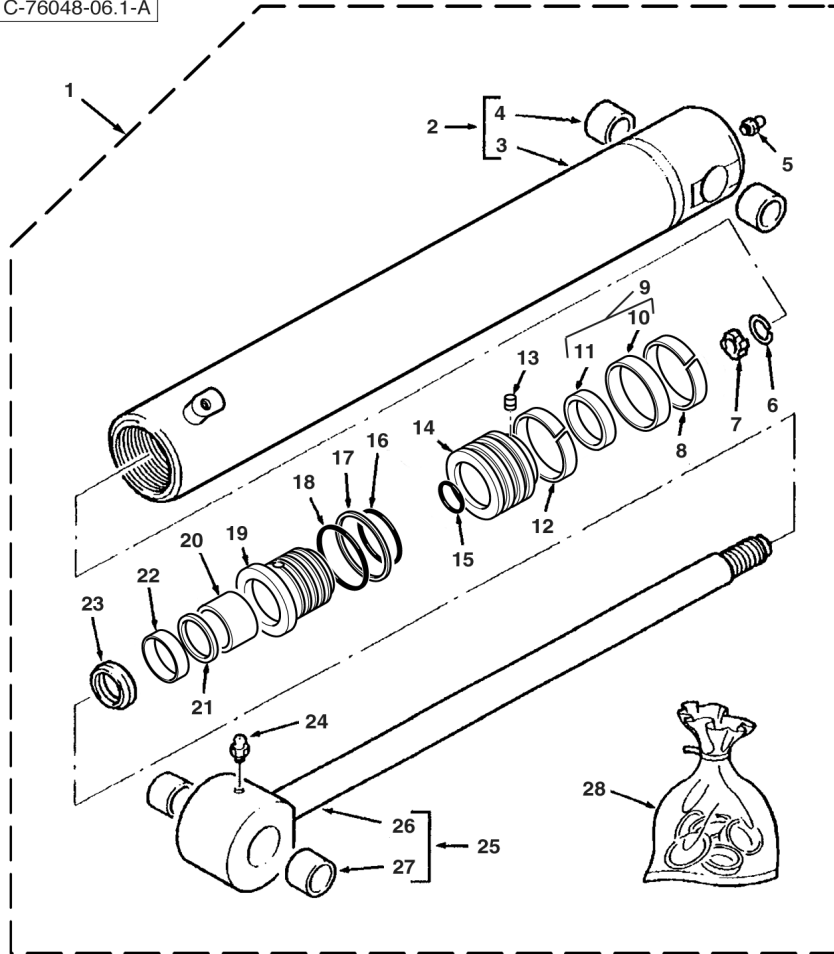

1	5000123M91	76048C05.1 1 4.9m Boom	1	Cylinder Assy	Ensemble de vérin	Gato, Conj.
2	5003993M91	1	1	Cylinder	Cylindre	Cilindro
3		2	1	Tube, Cylinder	Cylindre de vérin	Cilindro de gato
4		2 (C)	2	Bushing	Bague	Anillo
5	339608X1	1	1	Fitting, Grease	Graisser	Engrasador
6	1609899M1	1	1	Ring, Snap	Anneau d'arrêt	Anillo de resorte
7	1609328M1	1	1	Ring	Anneau	Aro
8	3403852M1	1 (A)	1	Ring	Anneau	Aro
9	3485213M91	1 (A)	1	Seal Assy	Ensemble de joint	Junta, Conj.
10		9	1	Seal	Joint	Junta
11		9	1	Seal	Joint	Junta
12	3403852M1	1	1	Ring	Anneau	Aro
13	3402928M1	1	1	Screw	Vis	Tornillo
14	3484189M1	1	1	Piston	Piston	Pistón
15	3007182X1	1 (A)	1	O-Ring	Joint torique	Junta de tipo O
16	359203X1	1 (A)	1	O-Ring	Joint torique	Junta de tipo O
17	367120X1	1 (A)	1	Ring	Anneau	Aro
18	3487909M1	1 (A)	1	O-Ring	Joint torique	Junta de tipo O
19	3623202M1	1	1	Bearing	Coussinet	Cojinete
20	3623193M1	1 (A)	1	Ring	Anneau	Aro
21	3443388M1	1 (A)	1	Ring	Anneau	Aro
22	3443472M1	1 (A)	1	Seal	Joint	Junta
23	3403385M1	1 (A)	1	Ring, Wiper	Joint de racleur	Junta raspador
24	339608X1	1	1	Fitting, Grease	Graisser	Engrasador
25	3441722M91	1	1	Rod, Piston	Tige de vérin	Vástago cilindro
26		25	1	Rod, Piston	Tige de vérin	Vástago cilindro
27	3484843M1	25	1	Bush	Bague	Casquillo
28	3623589M91	(B)	1	Kit, Seal	Pochette de joints	Juego de juntas

- A Included in kit marked (B)
 Inclus dans jeu marqué (B)
 Incluido en juego marcado (B)
- C Part number to be advised
 Référence pièce à demander
 Indicar número de pieza

- B Contains items marked (A)
 Comprend les pièces marquées (A)
 Incluye las piezas marcadas (A)



860 880 970 980
 TX870B TX970B

815 816 823 824 843 844 853 854 923 932

76048C06.1

6199042M3

1

Jan-06

Digger Hydraulics
Circuit Hydraulique Défonceuse
Circuito hidráulico equipo retro

Centremount
Montage de Pelle Central
Excavadora de montaje central

Swing Components
Organes de Rotation
Componentes de rotación

4.9m
 4.9m
 4.9m

C-76048-07.1-A

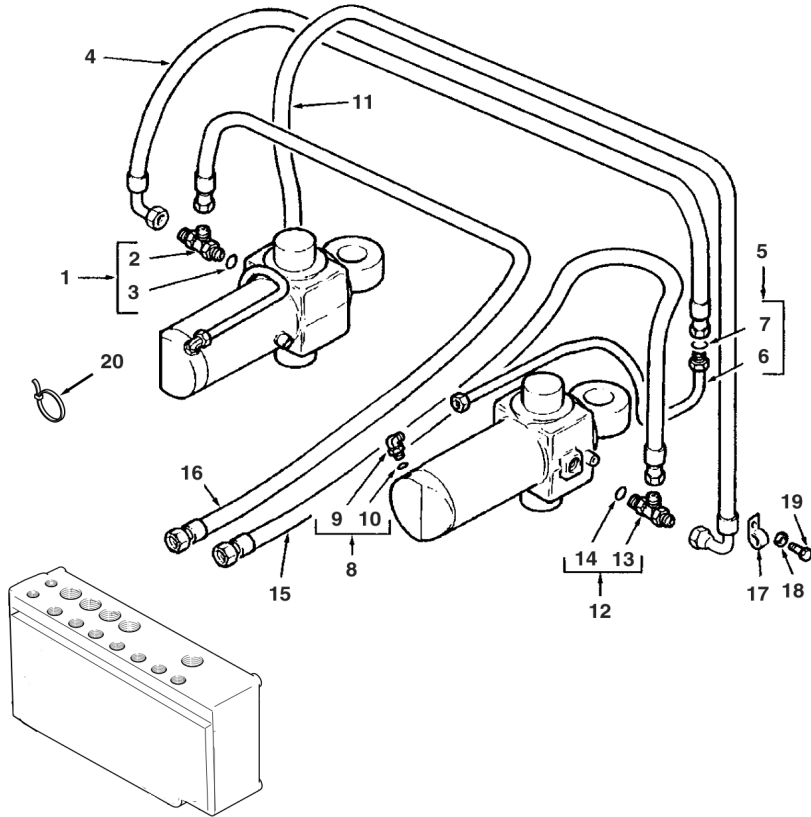

1	358728X91		1	Tee	Raccord en T	Te
2		1	▶ Ref. 1	1	Tee	Raccord en T
3	831497M1	1		1	O-Ring	Joint torique
4	6100716M91	840 mm		1	Hose Assy	Ensemble de flexible
5	6100587M91	◀		1	Tube Assy	Tuyauterie
5	6100589M91	▶		1	Tube Assy	Tuyauterie
6		5	▶ Ref. 5	1	Tube	Tube
7	394923X1	5		1	O-Ring	Joint torique
8	357197X91			2	Elbow, 90°	Coude à 90°
9		8	▶ Ref. 8	1	Elbow	Coude
10	831452M1	8		1	O-Ring	Joint torique
11	6100716M91	840 mm		1	Hose Assy	Ensemble de flexible
12	358728X91			1	Tee	Raccord en T
13		12	▶ Ref. 12	1	Tee	Raccord en T
14	831497M1	12		1	O-Ring	Joint torique
15	6100715M92	Purple 700mm		1	Hose Assy	Ensemble de flexible
16	6101866M93	Green 700mm		1	Hose Assy	Ensemble de flexible
17	3517114M2			2	Clip, Mounting	Collier de fixation
18	385361X1	M8		2	Washer	Rondelle
19	339228X1	M8 x 12		2	Screw	Vis
20	1862425M1			1	Tie, Cable	Attache câble



860 880 970 980
 TX870B TX970B

815 816 823 824 843 844 853 854 923 932

76048C07.1

6199042M3

1

Jan-06

Digger Hydraulics
Circuit Hydraulique Défonceuse
Circuito hidráulico equipo retro

Centremount
Montage de Pelle Central
Excavadora de montaje central

Bucket
 Godet
 Cuchara

4.9m
 4.9m
 4.9m

C-76049-01.1-A

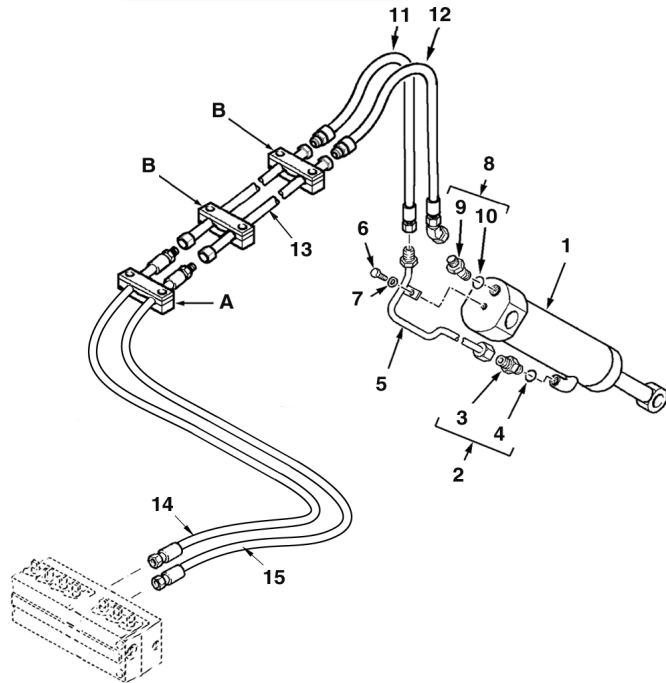
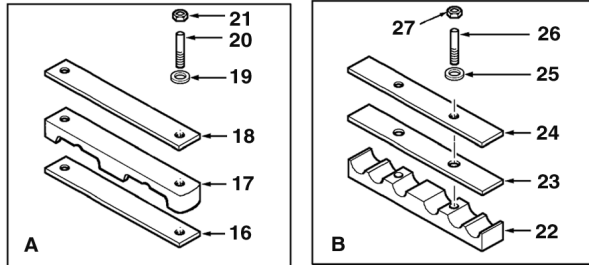

1	5000126M91	76049C02.1 1	1	Cylinder Assy	Ensemble de vérin	Gato, Conj.
2	835013M91		1	Connector Assy	Ensemble connexion	Conexión, Conj.
3		2 Ref. 2	1	Union	Union	Unión
4	835024M1	2	1	O-Ring	Joint torique	Junta de tipo O
5	6101540M91		1	Tube Assy	Tuyauterie	Conjunto de tubería
6	339123X1	M8 x 20	1	Bolt	Boulon	Perno
7	385361X1	M8	1	Washer	Rondelle	Arandela
8	835010M91		1	Elbow, 45°	Coude à 45°	Codo, 45°
9		8 Ref. 8	1	Elbow	Coude	Codo
10	835024M1	8	1	O-Ring	Joint torique	Junta de tipo O
11		(A)Brown	1	Hose Assy	Ensemble de flexible	Flexible, Conj.
12		(A)White	1	Hose Assy	Ensemble de flexible	Flexible, Conj.
13	6101431M91		2	Tube Assy	Tuyauterie	Conjunto de tubería
14	6102945M91	Brown	1	Hose Assy	Ensemble de flexible	Flexible, Conj.
15	6102942M91	White	1	Hose Assy	Ensemble de flexible	Flexible, Conj.
16	6102128M1		1	Pad	Plaque antidérapante	Cinta antideslizante
17	6102122M1		1	Bracket, Clamp	Bride de fixation	Brida de fijación
18	6102130M1		1	Plate	Plaque	Placa
19	390972X1	M8	2	Washer	Rondelle	Arandela
20	3516075M1	M8 x 65	2	Stud	Goujon	Espárrago
21	394367X1	M8	2	Nut, Lock	Écrou de blocage	Tuerca de retención
22	6102126M1		2	Bracket, Clamp	Bride de fixation	Brida de fijación
23	6102145M1		2	Pad	Plaque antidérapante	Cinta antideslizante
24	6102124M1		2	Plate	Plaque	Placa
25	390972X1	M8	4	Washer	Rondelle	Arandela
26	6108049M1		4	Stud	Goujon	Espárrago
27	394367X1	M8	4	Nut, Lock	Écrou de blocage	Tuerca de retención

A See extendahoe hydraulics section
 Voir la section circuit hydraulique extendahoe
 Ver la sección de la circuito hidráulico extendahoe



860 880 970 980
 TX870B TX970B

815 816 823 824 843 844 853 854 923 932

76049C01.1

6199042M3

1

Jan-06

Digger Hydraulics
Circuit Hydraulique Défonceuse
Circuito hidráulico equipo retro

Centremount
Montage de Pelle Central
Excavadora de montaje central

Bucket Cylinder
Vérin de Godet
Gato de cuchara

4.9m
 4.9m
 4.9m

C-76049-02.1-A

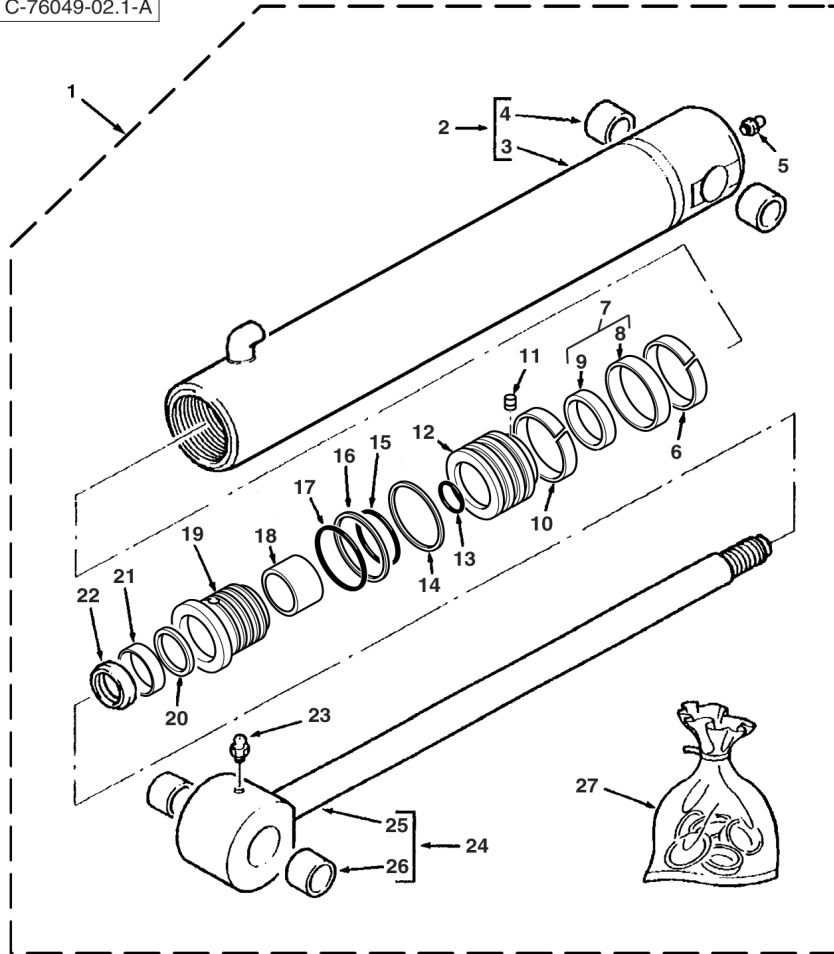

1	5000126M91		76049C01.1 1	1	Cylinder Assy	Ensemble de vérin	Gato, Conj.
2	5004008M91	1		1	Cylinder	Cylindre	Cilindro
3		3	Ref. 2	1	Tube, Cylinder	Cylindre de vérin	Cilindro de gato
4		3 (C)		1	Bushing	Bague	Anillo
5	339608X1	1		1	Fitting, Grease	Graisneur	Engrasador
6	3485892M1	1 (A)		1	Ring, Sealing	Bague d'étanchéité	Anillo, Estanqueidad
7	3485245M91	1 (A)		1	Seal Assy	Ensemble de joint	Junta, Conj.
8		7	Ref. 7	1	Seal	Joint	Junta
9		7	Ref. 7	1	Ring	Anneau	Aro
10	3485892M1	1 (A)		1	Ring, Sealing	Bague d'étanchéité	Anillo, Estanqueidad
11	3402928M1	1		1	Screw	Vis	Tornillo
12	3623372M1	1		1	Piston	Piston	Pistón
13	359186X1	1 (A)		1	O-Ring	Joint torique	Junta de tipo O
14	3623061M1	1		1	Ring, Piston	Segment de piston	Segmento de pistón
15	359193X1	1 (A)		1	O-Ring	Joint torique	Junta de tipo O
16	1606735M1	1 (A)		1	Ring, Backup	Contre-joint	ContraJunta
17	3487207M1	1 (A)		1	O-Ring	Joint torique	Junta de tipo O
18	3484615M1	1 (A)		1	Ring	Anneau	Aro
19	3623371M1	1		1	Bearing	Coussinet	Cojinete
20	3484055M1	1 (A)		1	Ring	Anneau	Aro
21	3485185M1	1 (A)		1	Seal	Joint	Junta
22	3487015M1	1 (A)		1	Ring	Anneau	Aro
23	339608X1	1		1	Fitting, Grease	Graisneur	Engrasador
24	5004012M91	1		1	Rod, Piston	Tige de vérin	Vástago cilindro
25		24	Ref. 24	1	Rod, Piston	Tige de vérin	Vástago cilindro
26		24 (C)		1	Bushing	Bague	Anillo
27	3623373M91		(B)	1	Kit, Seal	Pochette de joints	Juego de juntas

A Contains items marked (A)
 Comprend les pièces marquées (A)
 Incluye las piezas marcadas (A)
 C Part number to be advised
 Référence pièce à demander
 Indicar número de pieza

B Included in kit marked (B)
 Inclus dans jeu marqué (B)
 Incluido en juego marcado (B)



860 880 970 980
 TX870B TX970B

815 816 823 824 843 844 853 854 923 932

76049C02.1

6199042M3

1

Jan-06

Digger Hydraulics
Circuit Hydraulique Défonceuse
Circuito hidráulico equipo retro

Centremount
Montage de Pelle Central
Excavadora de montaje central

Telescopic Dipper
Balancier Téléscopique
Balancín telescópico

4.9m
 4.9m
 4.9m

C-76049-03.1-A

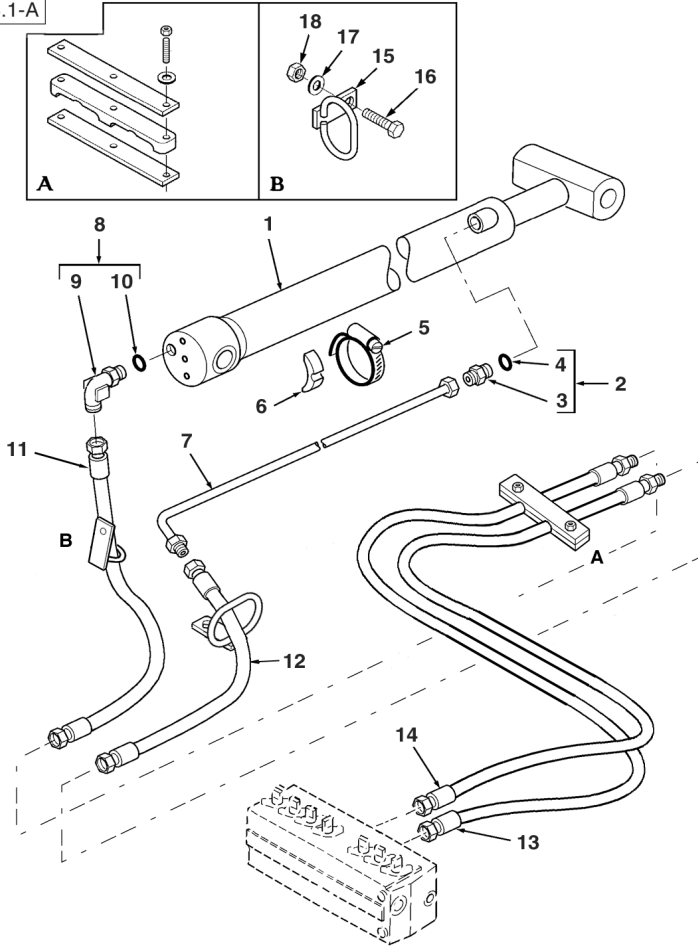

1	5000124M91	76049C04.1 1	1	Cylinder Assy	Ensemble de vérin	Gato, Conj.
2	835013M91		1	Connector Assy	Ensemble connexion	Conexión, Conj.
3		2 Ref. 2	1	Union	Union	Unión
4	835024M1	2	1	O-Ring	Joint torique	Junta de tipo O
5	3517733M1		1	Clamp	Collier de serrage	Argolla de cierre
6	L79937		1	Spacer	Entretoise	Travesa
7		(A,B)	1	Tube Assy	Tuyauterie	Conjunto de tubería
8		(A,B)	1	Elbow	Coude	Codo
9		8 (A,B) Ref. 8	1	Elbow	Coude	Codo
10		8 (A,B)	1	O-Ring	Joint torique	Junta de tipo O
11	6101738M91	Yellow	1	Hose Assy	Ensemble de flexible	Flexible, Conj.
12	6101737M91	Red	1	Hose Assy	Ensemble de flexible	Flexible, Conj.
13	6102941M91	Yellow	1	Hose Assy	Ensemble de flexible	Flexible, Conj.
14	6102944M91	Red	1	Hose Assy	Ensemble de flexible	Flexible, Conj.
15	6101491M92		2	Support Assy	Ensemble de support	Apoyadero, Conj.
16	339761X1	M8 x 25	2	Screw	Vis	Tornillo
17	390972X1	M8	2	Washer	Rondelle	Arandela
18	394367X1	M8	2	Nut, Lock	Écrou de blocage	Tuerca de retención

A Without Hose Burst
 Sans éclatement de tuyau
 Sin rotura de tubo flexible

B See hose burst section
 Voir la section éclatement de tuyau
 Ver la sección de rotura de tubo flexible



860 880 970 980
 TX870B TX970B

815 816 823 824 843 844 853 854 923 932

76049C03.1

6199042M3

1

Jan-06

Digger Hydraulics
Circuit Hydraulique Défonceuse
Circuito hidráulico equipo retro

Centremount
Montage de Pelle Central
Excavadora de montaje central

Dipper Cylinder
Vérin de Balancier
Gato de balancín

4.9m
 4.9m
 4.9m

C-76049-04.1-A

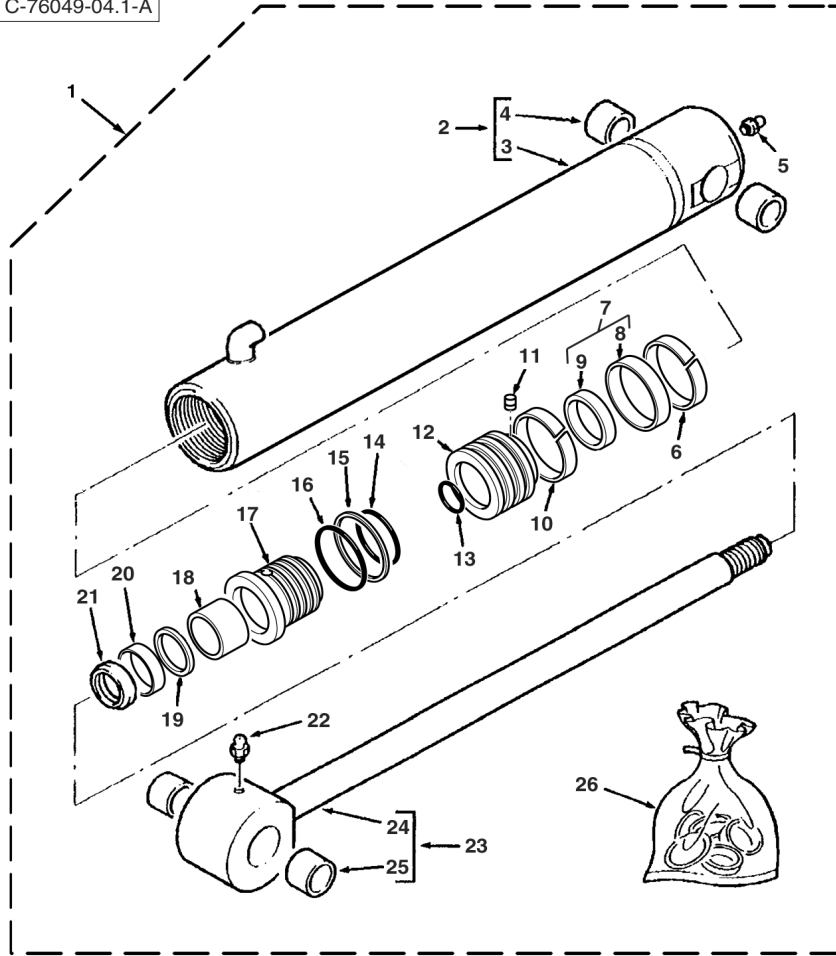

1	5000124M91		76049C03.1 1	1	Cylinder Assy	Ensemble de vérin	Gato, Conj.
2	5003982M91	1		1	Cylinder	Cylindre	Cilindro
3		2	Ref. 2	1	Tube, Cylinder	Cylindre de vérin	Cilindro de gato
4	3484843M1	2		1	Bush	Bague	Casquillo
5	339608X1	1		1	Fitting, Grease	Graisneur	Engrasador
6	3485891M1	1 (A)		1	Ring	Anneau	Aro
7	3485247M91	1 (A)		1	Seal Assy	Ensemble de joint	Junta, Conj.
8		7	Ref. 7	1	Seal	Joint	Junta
9		7	Ref. 7	1	Ring	Anneau	Aro
10	3485891M1	1 (A)		1	Ring	Anneau	Aro
11	3402928M1	1		1	Screw	Vis	Tornillo
12	5003989M1	1		1	Piston	Piston	Pistón
13	3007182X1	1 (A)		1	O-Ring	Joint torique	Junta de tipo O
14	359196X1	1 (A)		1	O-Ring	Joint torique	Junta de tipo O
15	378545X1	1 (A)		1	Ring	Anneau	Aro
16	3487908M1	1 (A)		1	O-Ring	Joint torique	Junta de tipo O
17	5003988M1	1		1	Bearing	Coussinet	Cojinete
18	3623193M1	1 (A)		1	Ring	Anneau	Aro
19	3443388M1	1 (A)		1	Ring	Anneau	Aro
20	3443472M1	1 (A)		1	Seal	Joint	Junta
21	3403385M1	1 (A)		1	Ring, Wiper	Joint de racler	Junta raspador
22	339608X1	1		1	Fitting, Grease	Graisneur	Engrasador
23	5003985M91	1		1	Rod, Piston	Tige de vérin	Vástago cilindro
24		23	Ref. 23	1	Rod, Piston	Tige de vérin	Vástago cilindro
25	3484843M1	23		1	Bush	Bague	Casquillo
26	5004401M91		(B)	1	Kit, Seal	Pochette de joints	Juego de juntas

A Included in kit marked (B)
 Inclus dans jeu marqué (B)
 Incluido en juego marcado (B)

B Contains items marked (A)
 Comprend les pièces marquées (A)
 Incluye las piezas marcadas (A)



860 880 970 980
 TX870B TX970B

815 816 823 824 843 844 853 854 923 932

76049C04.1

6199042M3

1

Jan-06

Digger Hydraulics
Circuit Hydraulique Défonceuse
Circuito hidráulico equipo retro

Centremount
Montage de Pelle Central
Excavadora de montaje central

Boom
 Flèche
 Pluma

4.9m
 4.9m
 4.9m

C-76049-05.1-A

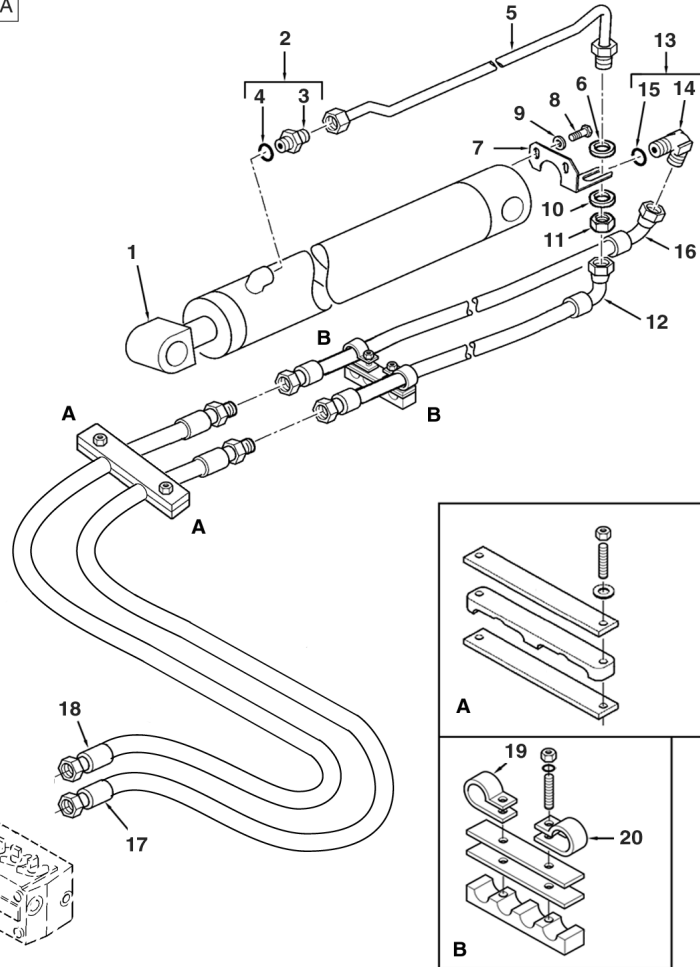

1	5000123M91	76049C06.1 1 4.9m Boom	1	Cylinder Assy	Ensemble de vérin	Gato, Conj.
2	835013M91		1	Connector Assy	Ensemble connexion	Conexión, Conj.
3		Ref. 2	1	Union	Union	Unión
4	835024M1		1	O-Ring	Joint torique	Junta de tipo O
5		(A,B)	1	Tube Assy	Tuyauterie	Conjunto de tubería
6		(A,B)	1	Washer	Rondelle	Arandela
7		(A,B)	1	Bracket	Patte de fixation	Pata de fijación
8	339228X1	M8 x 12	2	Screw	Vis	Tornillo
9	339374X1	M8	2	Washer, Lock	Rondelle de blocage	Arandela de freno
10		(A,B)	1	Washer	Rondelle	Arandela
11		(A,B)	1	Nut	Écrou	Tuerca
12		(A,B)Orange	1	Hose Assy	Ensemble de flexible	Flexible, Conj.
13		(A,B)	1	Elbow	Coude	Codo
14		(A,B) Ref. 13	1	Elbow	Coude	Codo
15		13 (A,B)	1	O-Ring	Joint torique	Junta de tipo O
16	6101736M92	Blue	1	Hose Assy	Ensemble de flexible	Flexible, Conj.
17	6102943M91	Orange	1	Hose Assy	Ensemble de flexible	Flexible, Conj.
18	6102940M91	Blue	1	Hose Assy	Ensemble de flexible	Flexible, Conj.
19	515-23270		1	Clip	Clip	Clip
20	515-23206		1	Clip	Clip	Clip

A Without Hose Burst
 Sans éclatement de tuyau
 Sin rotura de tubo flexible

B See hose burst section
 Voir la section éclatement de tuyau
 Ver la sección de rotura de tubo flexible



860 880 970 980
 TX870B TX970B

815 816 823 824 843 844 853 854 923 932

76049C05.1

6199042M3

1

Jan-06

Digger Hydraulics
Circuit Hydraulique Défonceuse
Circuito hidráulico equipo retro

Centremount
Montage de Pelle Central
Excavadora de montaje central

Boom Cylinder
Vérin de Flèche
Gato de pluma

4.9m
4.9m
4.9m

C-76049-06.1-A

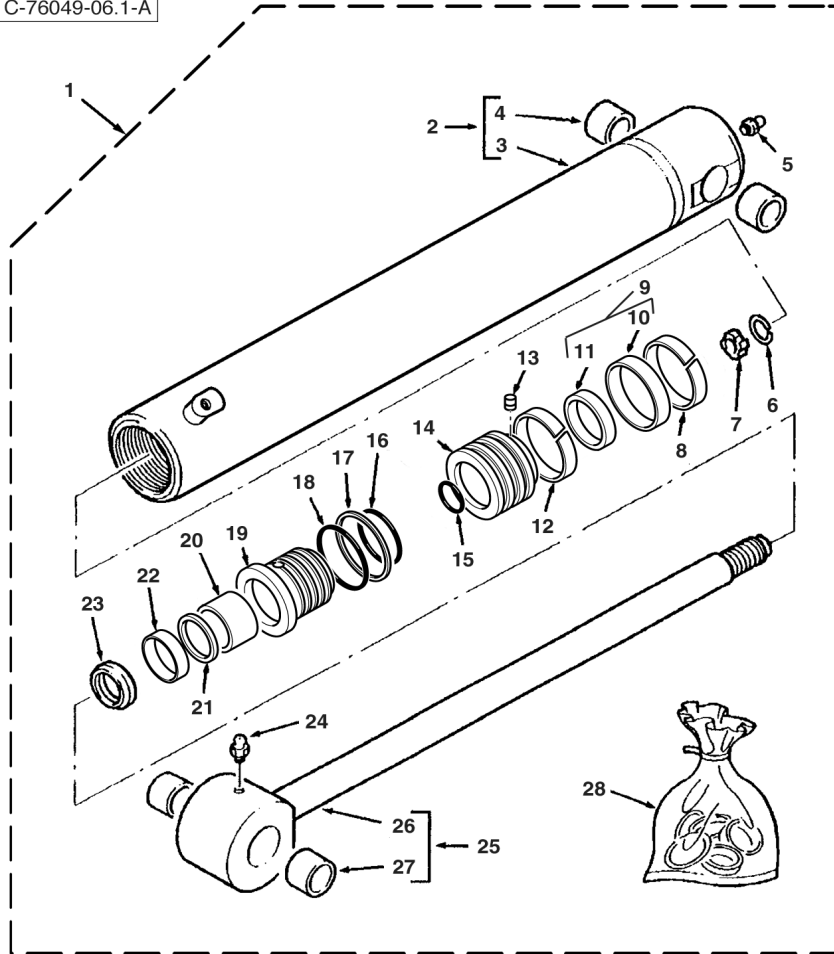

1	5000123M91	76049C05.1 1 4.9m Boom	1	Cylinder Assy	Ensemble de vérin	Gato, Conj.
2	5003993M91	1	1	Cylinder	Cylindre	Cilindro
3		2	1	Tube, Cylinder	Cylindre de vérin	Cilindro de gato
4		2 (C)	2	Bushing	Bague	Anillo
5	339608X1	1	1	Fitting, Grease	Graisseur	Engrasador
6	1609899M1	1	1	Ring, Snap	Anneau d'arrêt	Anillo de resorte
7	1609328M1	1	1	Ring	Anneau	Aro
8	3403852M1	1 (A)	1	Ring	Anneau	Aro
9	3485213M91	1 (A)	1	Seal Assy	Ensemble de joint	Junta, Conj.
10		9	1	Seal	Joint	Junta
11		9	1	Seal	Joint	Junta
12	3403852M1	1	1	Ring	Anneau	Aro
13	3402928M1	1	1	Screw	Vis	Tornillo
14	3484189M1	1	1	Piston	Piston	Pistón
15	3007182X1	1 (A)	1	O-Ring	Joint torique	Junta de tipo O
16	359203X1	1 (A)	1	O-Ring	Joint torique	Junta de tipo O
17	367120X1	1 (A)	1	Ring	Anneau	Aro
18	3487909M1	1 (A)	1	O-Ring	Joint torique	Junta de tipo O
19	3623202M1	1	1	Bearing	Coussinet	Cojinete
20	3623193M1	1 (A)	1	Ring	Anneau	Aro
21	3443388M1	1 (A)	1	Ring	Anneau	Aro
22	3443472M1	1 (A)	1	Seal	Joint	Junta
23	3403385M1	1 (A)	1	Ring, Wiper	Joint de racleur	Junta raspador
24	339608X1	1	1	Fitting, Grease	Graisseur	Engrasador
25	3441722M91	1	1	Rod, Piston	Tige de vérin	Vástago cilindro
26		25	1	Rod, Piston	Tige de vérin	Vástago cilindro
27	3484843M1	25	1	Bush	Bague	Casquillo
28	3623589M91	(B)	1	Kit, Seal	Pochette de joints	Juego de juntas

A Included in kit marked (B)
 Inclus dans jeu marqué (B)
 Incluido en juego marcado (B)

C Part number to be advised
 Référence pièce à demander
 Indicar número de pieza

B Contains items marked (A)
 Comprend les pièces marquées (A)
 Incluye las piezas marcadas (A)



860 880 970 980
 TX870B TX970B

815 816 823 824 843 844 853 854 923 932

76049C06.1

6199042M3

1

Jan-06

Digger Hydraulics
Circuit Hydraulique Défonceuse
Circuito hidráulico equipo retro

Centremount
Montage de Pelle Central
Excavadora de montaje central

Swing Components
Organes de Rotation
Componentes de rotación

4.9m
 4.9m
 4.9m

C-76049-07.1-A

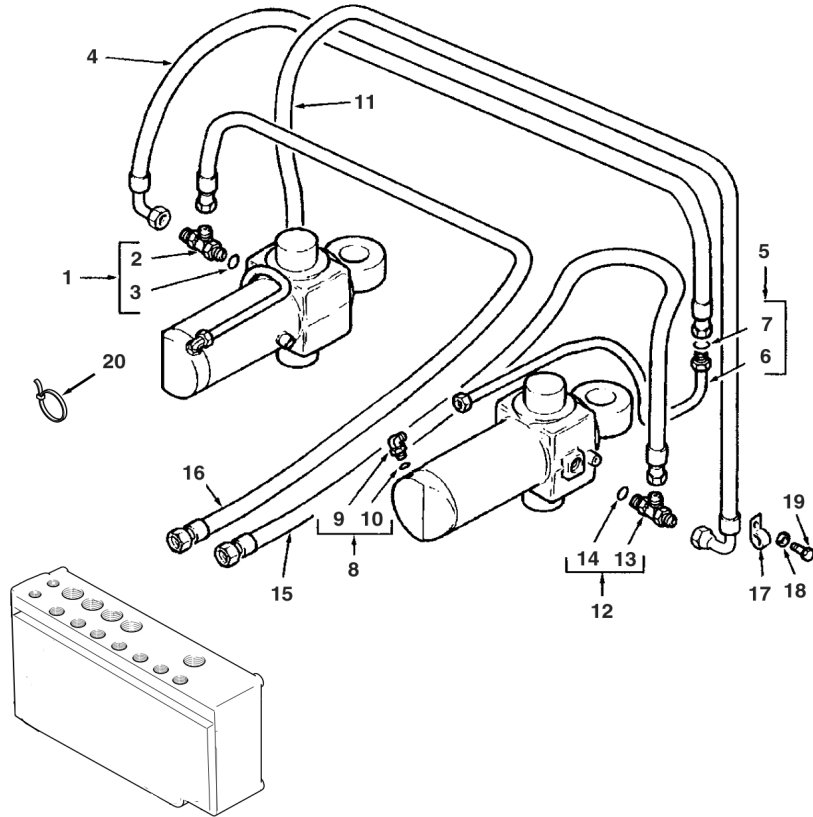

1	358728X91		1	Tee	Raccord en T	Te
2		1	▶ Ref. 1	1	Tee	Raccord en T
3	831497M1	1		1	O-Ring	Joint torique
4	6100716M91	840 mm		1	Hose Assy	Ensemble de flexible
5	6100587M91	▶		1	Tube Assy	Tuyauterie
5	6100589M91	▶		1	Tube Assy	Tuyauterie
6		5	▶ Ref. 5	1	Tube	Tube
7	394923X1	5		1	O-Ring	Joint torique
8	357197X91			2	Elbow, 90°	Coude à 90°
9		8	▶ Ref. 8	1	Elbow	Coude
10	831452M1	8		1	O-Ring	Joint torique
11	6100716M91	840 mm		1	Hose Assy	Ensemble de flexible
12	358728X91			1	Tee	Raccord en T
13		12	▶ Ref. 12	1	Tee	Raccord en T
14	831497M1	12		1	O-Ring	Joint torique
15	6100715M92	Purple 700mm		1	Hose Assy	Ensemble de flexible
16	6101866M93	Green 700mm		1	Hose Assy	Ensemble de flexible
17	3517114M2			2	Clip, Mounting	Collier de fixation
18	385361X1	M8		2	Washer	Rondelle
19	339228X1	M8 x 12		2	Screw	Vis
20	1862425M1			1	Tie, Cable	Attache câble



860 880 970 980
 TX870B TX970B

815 816 823 824 843 844 853 854 923 932

76049C07.1

6199042M3

1

Jan-06

Digger Hydraulics
Circuit Hydraulique Défonceuse
Circuito hidráulico equipo retro

Sideshift
Montage de Pelle Latéral
Excavadora de montaje horizontal

Bucket
 Godet
 Cuchara

Std. Spec.
 Std. Spec.
 Std. Spec.

C-76030-01.1-A

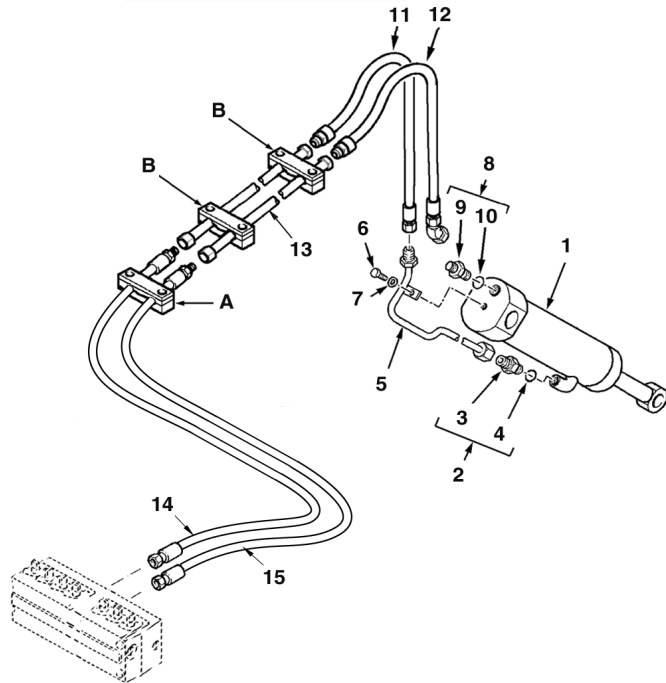
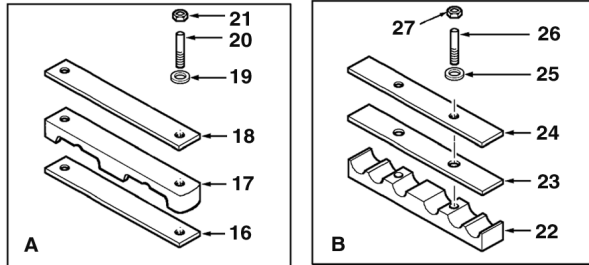

1	5000126M91	76030C02.1	1	Cylinder Assy	Ensemble de vérin	Gato, Conj.
2	835013M91		1	Connector Assy	Ensemble connexion	Conexión, Conj.
3		2 Ref. 2	1	Union	Union	Unión
4	835024M1	2	1	O-Ring	Joint torique	Junta de tipo O
5	6101540M91		1	Tube Assy	Tuyauterie	Conjunto de tubería
6	339123X1	M8 x 20	1	Bolt	Boulon	Perno
7	385361X1	M8	1	Washer	Rondelle	Arandela
8	835013M91		1	Connector Assy	Ensemble connexion	Conexión, Conj.
9		8 Ref. 8	1	Union	Union	Unión
10	835024M1	8	1	O-Ring	Joint torique	Junta de tipo O
11	6102309M91	Brown	1	Hose Assy	Ensemble de flexible	Flexible, Conj.
12	6107024M91	White	1	Hose Assy	Ensemble de flexible	Flexible, Conj.
13	6101771M91		2	Tube Assy	Tuyauterie	Conjunto de tubería
14	6108762M91	Brown	1	Hose Assy	Ensemble de flexible	Flexible, Conj.
15	6108763M91	White	1	Hose Assy	Ensemble de flexible	Flexible, Conj.
16	6102128M1		1	Pad	Plaque antidérapante	Cinta antideslizante
17	6102122M1		1	Bracket, Clamp	Bride de fixation	Brida de fijación
18	6102130M1		1	Plate	Plaque	Placa
19	390972X1	M8	2	Washer	Rondelle	Arandela
20	3516075M1	M8 x 65	2	Stud	Goujon	Espárrago
21	394367X1	M8	2	Nut, Lock	Écrou de blocage	Tuerca de retención
22	6102126M1		2	Bracket, Clamp	Bride de fixation	Brida de fijación
23	6102145M1		2	Pad	Plaque antidérapante	Cinta antideslizante
24	6102124M1		2	Plate	Plaque	Placa
25	390972X1	M8	4	Washer	Rondelle	Arandela
26	6108049M1		4	Stud	Goujon	Espárrago
27	394367X1	M8	4	Nut, Lock	Écrou de blocage	Tuerca de retención



820
 TX760B

805 806 807 808 833 834

76030C01.1

6199042M3

1

Jan-06

Digger Hydraulics
Circuit Hydraulique Défonceuse
Circuito hidráulico equipo retro

Sideshift
Montage de Pelle Latéral
Excavadora de montaje horizontal

Bucket Cylinder
Vérin de Godet
Gato de cuchara

Std. Spec.
 Std. Spec.
 Std. Spec.

C-76030-02.1-A

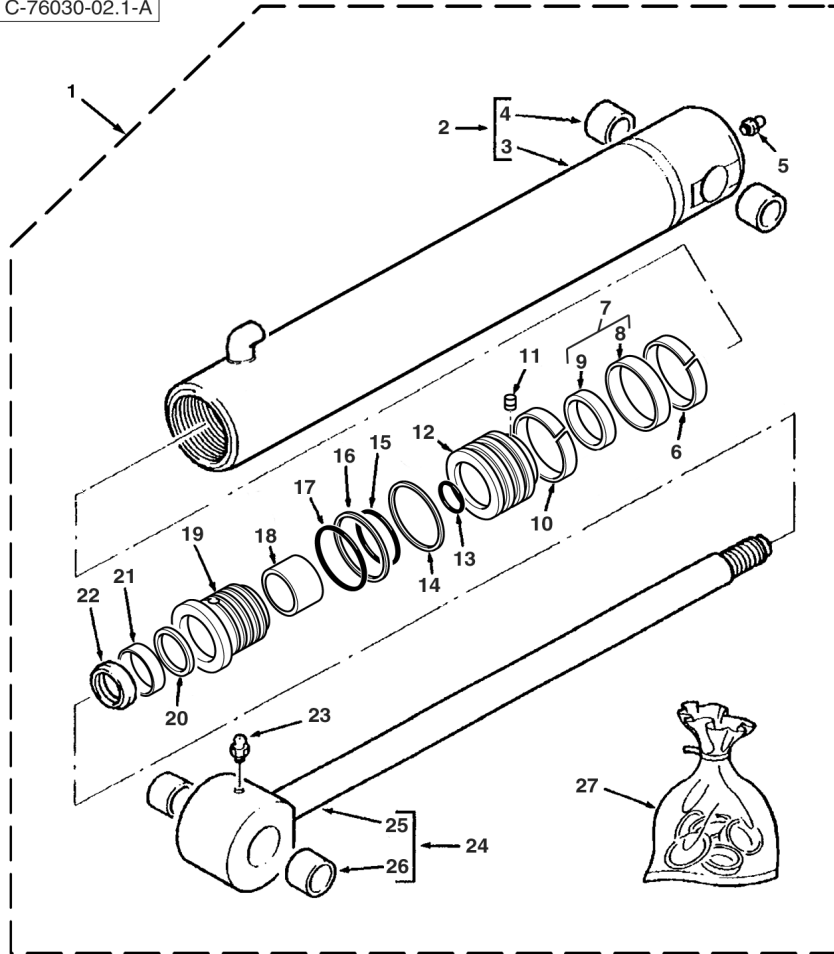

1	5000126M91		76030C01.1	1	Cylinder Assy	Ensemble de vérin	Gato, Conj.
2	5004008M91	1		1	Cylinder	Cylindre	Cilindro
3		3	Ref. 2	1	Tube, Cylinder	Cylindre de vérin	Cilindro de gato
4		3 (C)		1	Bushing	Bague	Anillo
5	339608X1	1		1	Fitting, Grease	Graisneur	Engrasador
6	3485892M1	1 (A)		1	Ring, Sealing	Bague d'étanchéité	Anillo, Estanqueidad
7	3485245M91	1 (A)		1	Seal Assy	Ensemble de joint	Junta, Conj.
8		7	Ref. 7	1	Seal	Joint	Junta
9		7	Ref. 7	1	Ring	Anneau	Aro
10	3485892M1	1 (A)		1	Ring, Sealing	Bague d'étanchéité	Anillo, Estanqueidad
11	3402928M1	1		1	Screw	Vis	Tornillo
12	3623372M1	1		1	Piston	Piston	Pistón
13	359186X1	1 (A)		1	O-Ring	Joint torique	Junta de tipo O
14	3623061M1	1		1	Ring, Piston	Segment de piston	Segmento de pistón
15	359193X1	1 (A)		1	O-Ring	Joint torique	Junta de tipo O
16	1606735M1	1 (A)		1	Ring, Backup	Contre-joint	ContraJunta
17	3487207M1	1 (A)		1	O-Ring	Joint torique	Junta de tipo O
18	3484615M1	1 (A)		1	Ring	Anneau	Aro
19	3623371M1	1		1	Bearing	Coussinet	Cojinete
20	3484055M1	1 (A)		1	Ring	Anneau	Aro
21	3485185M1	1 (A)		1	Seal	Joint	Junta
22	3487015M1	1 (A)		1	Ring	Anneau	Aro
23	339608X1	1		1	Fitting, Grease	Graisneur	Engrasador
24	5004012M91	1		1	Rod, Piston	Tige de vérin	Vástago cilindro
25		24	Ref. 24	1	Rod, Piston	Tige de vérin	Vástago cilindro
26		24 (C)		1	Bushing	Bague	Anillo
27	3623373M91		(B)	1	Kit, Seal	Pochette de joints	Juego de juntas

A Contains items marked (A)
 Comprend les pièces marquées (A)
 Incluye las piezas marcadas (A)

C Part number to be advised
 Référence pièce à demander
 Indicar número de pieza

B Included in kit marked (B)
 Inclus dans jeu marqué (B)
 Incluido en juego marcado (B)



820
 TX760B

805 806 807 808 833 834

76030C02.1

6199042M3

1

Jan-06

Digger Hydraulics
Circuit Hydraulique Défonceuse
Circuito hidráulico equipo retro

Sideshift
Montage de Pelle Latéral
Excavadora de montaje horizontal

Standard Dipper
Balancier Standard
Balancín estándar

Std. Spec.
 Std. Spec.
 Std. Spec.

C-76030-03.1-A

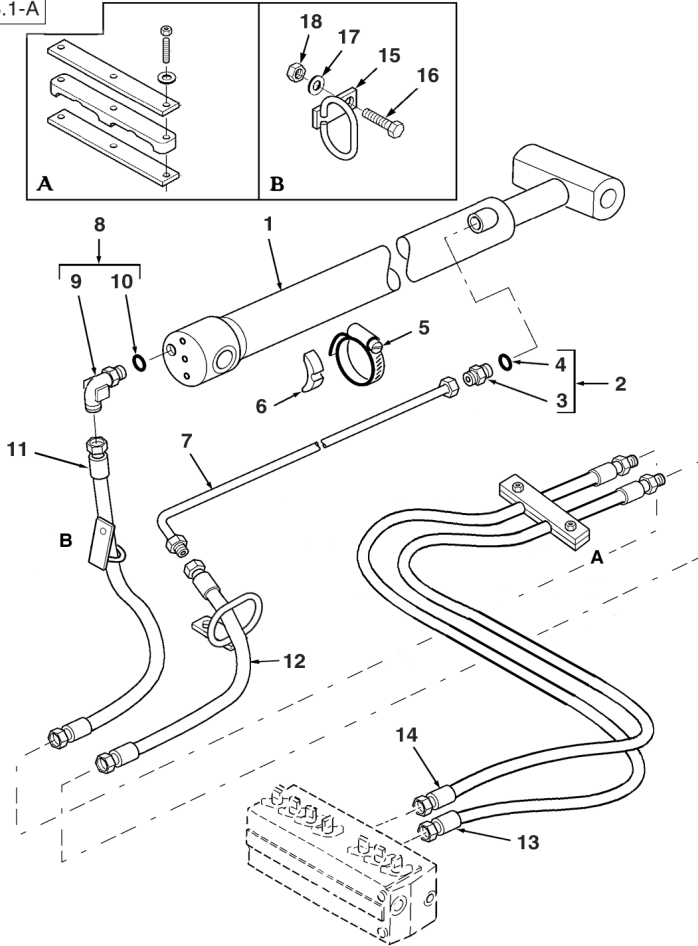

1	5000124M91	76030C04.1	1	Cylinder Assy	Ensemble de vérin	Gato, Conj.
2	835013M91		1	Connector Assy	Ensemble connexion	Conexión, Conj.
3		2	1	Union	Union	Unión
4	835024M1	2	1	O-Ring	Joint torique	Junta de tipo O
5	3517733M1		1	Clamp	Collier de serrage	Argolla de cierre
6	L79937		1	Spacer	Entretoise	Travesa
7	6100976M92	(A)	1	Tube Assy	Tuyauterie	Conjunto de tubería
8	6101624M91	(A)	1	Elbow, 90°	Coude à 90°	Codo, 90°
9		8	1	Elbow	Coude	Codo
10	835024M1	8	1	O-Ring	Joint torique	Junta de tipo O
11	6101738M91	Yellow	1	Hose Assy	Ensemble de flexible	Flexible, Conj.
12	6101737M91	Red	1	Hose Assy	Ensemble de flexible	Flexible, Conj.
13	6108767M91	Yellow	1	Hose Assy	Ensemble de flexible	Flexible, Conj.
14	6108766M91	Red	1	Hose Assy	Ensemble de flexible	Flexible, Conj.
15	6101491M92		2	Support Assy	Ensemble de support	Apoyadero, Conj.
16	339761X1	M8 x 25	2	Screw	Vis	Tornillo
17	390972X1	M8	2	Washer	Rondelle	Arandela
18	394367X1	M8	2	Nut, Lock	Écrou de blocage	Tuerca de retención

A Without Hose Burst
 Sans éclatement de tuyau
 Sin rotura de tubo flexible



820
 TX760B

805 806 807 808 833 834

76030C03.1

6199042M3

1

Jan-06

Digger Hydraulics
Circuit Hydraulique Défonceuse
Circuito hidráulico equipo retro

Sideshift
Montage de Pelle Latéral
Excavadora de montaje horizontal

Dipper Cylinder
Vérin de Balancier
Gato de balancín

Std. Spec.
 Std. Spec.
 Std. Spec.

C-76030-04.1-A

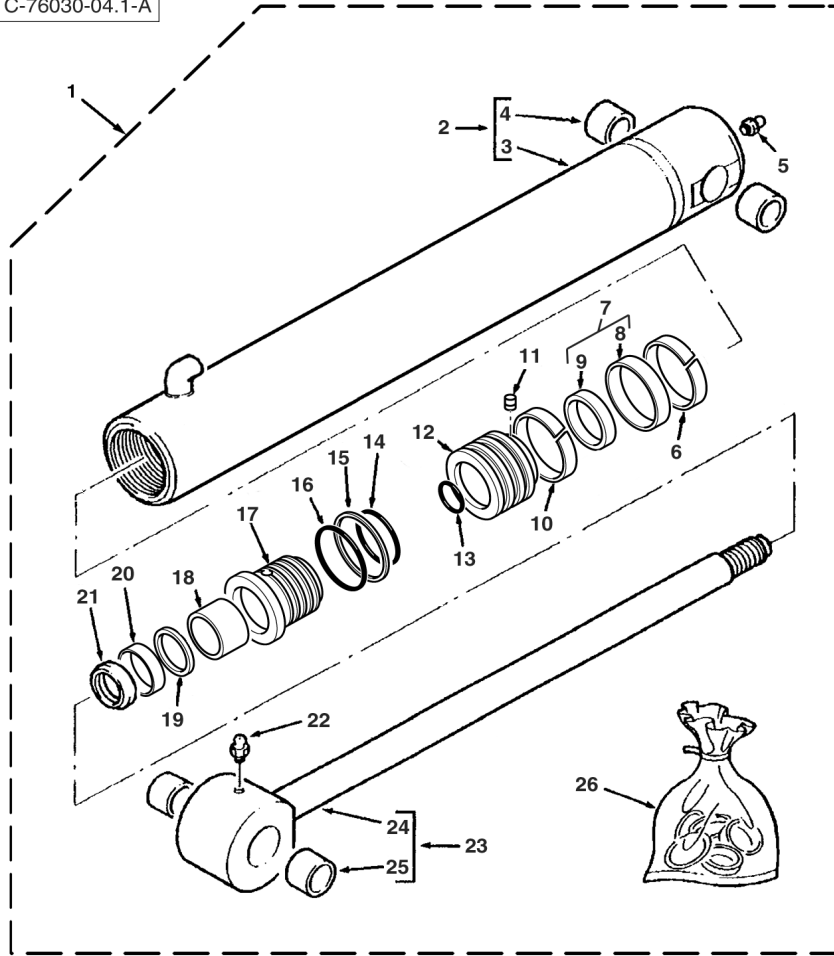

1	5000124M91	76030C03.1	1	Cylinder Assy	Ensemble de vérin	Gato, Conj.
2	5003982M91		1	Cylinder	Cylindre	Cilindro
3		Ref. 2	1	Tube, Cylinder	Cylindre de vérin	Cilindro de gato
4	3484843M1		2	Bush	Bague	Casquillo
5	339608X1		1	Fitting, Grease	Graisneur	Engrasador
6	3485891M1	(A)	1	Ring	Anneau	Aro
7	3485247M91	(A)	1	Seal Assy	Ensemble de joint	Junta, Conj.
8		Ref. 7	1	Seal	Joint	Junta
9		Ref. 7	1	Ring	Anneau	Aro
10	3485891M1	(A)	1	Ring	Anneau	Aro
11	3402928M1		1	Screw	Vis	Tornillo
12	5003989M1		1	Piston	Piston	Pistón
13	3007182X1	(A)	1	O-Ring	Joint torique	Junta de tipo O
14	359196X1	(A)	1	O-Ring	Joint torique	Junta de tipo O
15	378545X1	(A)	1	Ring	Anneau	Aro
16	3487908M1	(A)	1	O-Ring	Joint torique	Junta de tipo O
17	5003988M1		1	Bearing	Coussinet	Cojinete
18	3623193M1	(A)	1	Ring	Anneau	Aro
19	3443388M1	(A)	1	Ring	Anneau	Aro
20	3443472M1	(A)	1	Seal	Joint	Junta
21	3403385M1	(A)	1	Ring, Wiper	Joint de racleur	Junta raspador
22	339608X1		1	Fitting, Grease	Graisneur	Engrasador
23	5003985M91		1	Rod, Piston	Tige de vérin	Vástago cilindro
24		Ref. 23	1	Rod, Piston	Tige de vérin	Vástago cilindro
25	3484843M1		23	Bush	Bague	Casquillo
26	5004401M91	(B)	1	Kit, Seal	Pochette de joints	Juego de juntas

A Included in kit marked (B)
 Inclus dans jeu marqué (B)
 Incluido en juego marcado (B)

B Contains items marked (A)
 Comprend les pièces marquées (A)
 Incluye las piezas marcadas (A)



820
 TX760B

805 806 807 808 833 834

76030C04.1

6199042M3

1

Jan-06

Digger Hydraulics
Circuit Hydraulique Défonceuse
Circuito hidráulico equipo retro

Sideshift
Montage de Pelle Latéral
Excavadora de montaje horizontal

Boom
 Flèche
 Pluma

Std. Spec.
 Std. Spec.
 Std. Spec.

C-76030-05.1-A

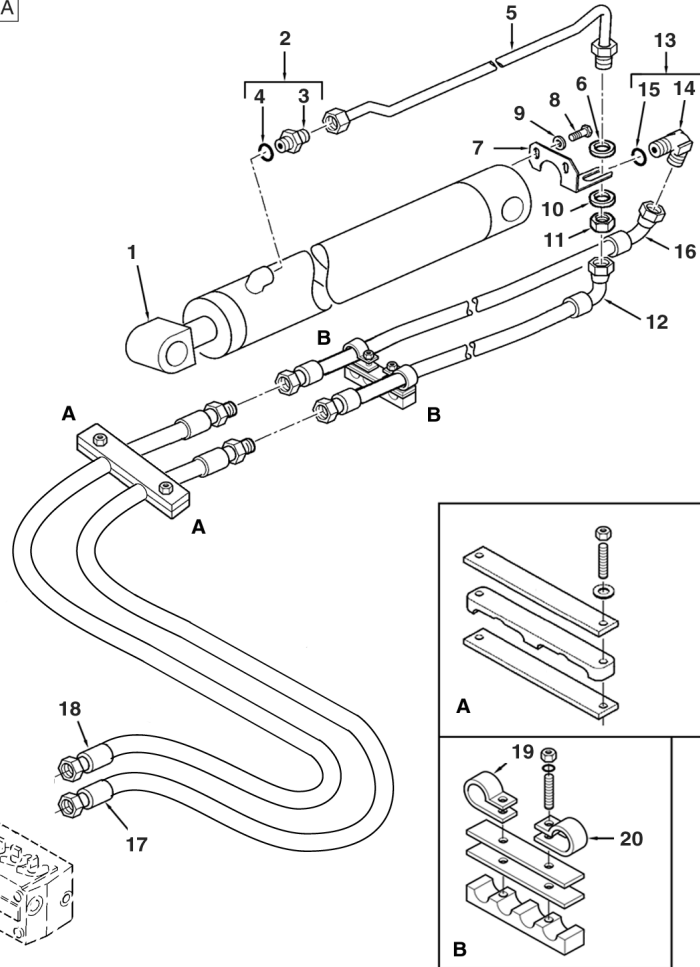

1	5000121M91	76030C06.1	1	Cylinder Assy	Ensemble de vérin	Gato, Conj.
2	835013M91		1	Connector Assy	Ensemble connexion	Conexión, Conj.
3		2	1	Union	Union	Unión
4	835024M1	2	1	O-Ring	Joint torique	Junta de tipo O
5	6100855M91	(A)	1	Tube Assy	Tuyauterie	Conjunto de tubería
6	353763X1	(A)	1	Washer	Rondelle	Arandela
7	6100883M1	(A)	1	Bracket	Patte de fixation	Pata de fijación
8	339228X1	M8 x 12	2	Screw	Vis	Tornillo
9	339374X1	M8	2	Washer, Lock	Rondelle de blocage	Arandela de freno
10	353763X1	(A)	1	Washer	Rondelle	Arandela
11	355574X1	(A)	1	Nut	Écrou	Tuerca
12	6101735M92	(A) Orange	1	Hose Assy	Ensemble de flexible	Flexible, Conj.
13	835007M91	(A)	1	Elbow, 90°	Coude à 90°	Codo, 90°
14		13	1	Elbow	Coude	Codo
15	835024M1	13	1	O-Ring	Joint torique	Junta de tipo O
16	6101736M92	Blue	1	Hose Assy	Ensemble de flexible	Flexible, Conj.
17	6108761M91	Orange	1	Hose Assy	Ensemble de flexible	Flexible, Conj.
18	6108760M91	Blue	1	Hose Assy	Ensemble de flexible	Flexible, Conj.
19	515-23270		1	Clip	Clip	Clip
20	515-23206		1	Clip	Clip	Clip

A Without Hose Burst
 Sans éclatement de tuyau
 Sin rotura de tubo flexible



820
 TX760B

805 806 807 808 833 834

76030C05.1

6199042M3

1

Jan-06

Digger Hydraulics
Circuit Hydraulique Défonceuse
Circuito hidráulico equipo retro

Sideshift
Montage de Pelle Latéral
Excavadora de montaje horizontal

Boom Cylinder
Vérin de Flèche
Gato de pluma

Std. Spec.
 Std. Spec.
 Std. Spec.

C-76030-06.1-A

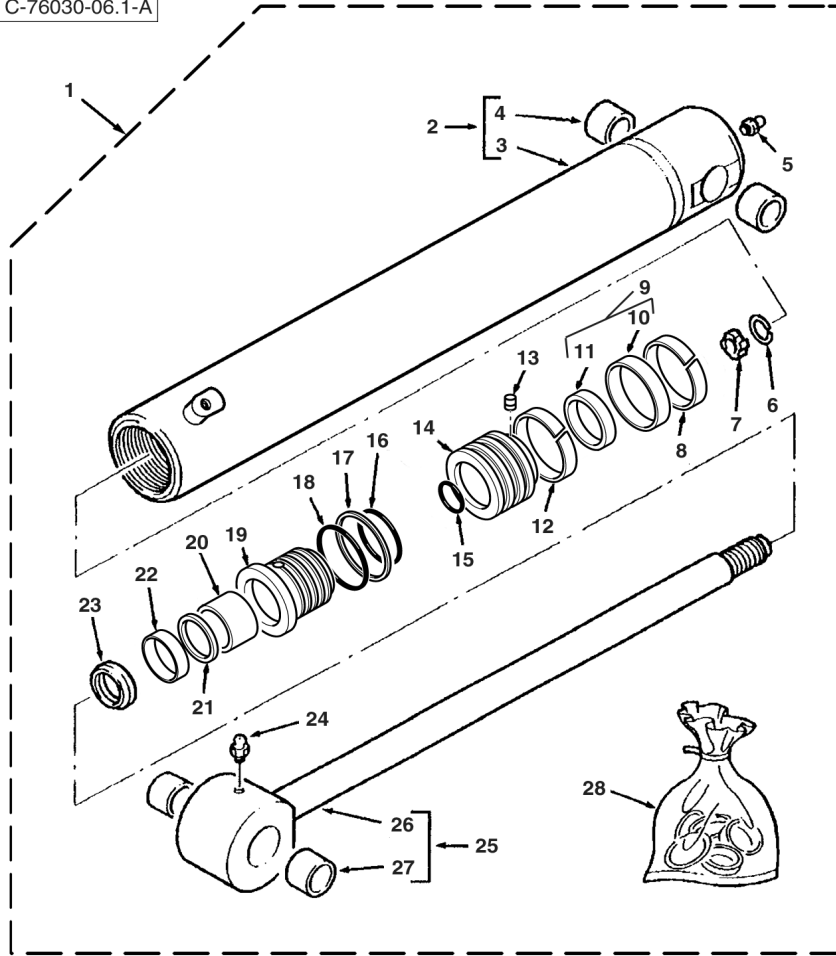

1	5000121M91	76030C05.1	1	Cylinder Assy	Ensemble de vérin	Gato, Conj.
2	5003974M91		1	Cylinder	Cylindre	Cilindro
3		2	Ref. 2	Tube, Cylinder	Cylindre de vérin	Cilindro de gato
4		2 (C)		Bushing	Bague	Anillo
5	339608X1		1	Fitting, Grease	Graisneur	Engrasador
6	1609899M1		1	Ring, Snap	Anneau d'arrêt	Anillo de resorte
7	1609328M1		1	Ring	Anneau	Aro
8	3442376M1	(A)	2	Ring	Anneau	Aro
9	3485249M91	(A)	1	Seal	Joint	Junta
10		9	Ref. 9	Seal	Joint	Junta
11		9	Ref. 9	Seal	Joint	Junta
13	3402928M1		1	Screw	Vis	Tornillo
14	5003980M1		1	Piston	Piston	Pistón
15	3007182X1	(A)	1	O-Ring	Joint torique	Junta de tipo O
16	359201X1	(A)	1	O-Ring	Joint torique	Junta de tipo O
17	1024334M1	(A)	1	Ring	Anneau	Aro
18	3487909M1	(A)	1	O-Ring	Joint torique	Junta de tipo O
19	5003979M1		1	Bearing	Coussinet	Cojinete
20	3623193M1	(A)	1	Ring	Anneau	Aro
21	3443388M1	(A)	1	Ring	Anneau	Aro
22	3443472M1	(A)	1	Seal	Joint	Junta
23	3403385M1	(A)	1	Ring, Wiper	Joint de racleur	Junta raspador
24	339608X1		1	Fitting, Grease	Graisneur	Engrasador
25	3441629M91		1	Rod, Piston	Tige de vérin	Vástago cilindro
26		25	Ref. 25	Rod, Piston	Tige de vérin	Vástago cilindro
27	3484843M1	25		Bush	Bague	Casquillo
28	5004400M91	(B)	1	Kit, Seal	Pochette de joints	Juego de juntas

A Included in kit marked (B)
 Inclus dans jeu marqué (B)
 Incluido en juego marcado (B)

C Part number to be advised
 Référence pièce à demander
 Indicar número de pieza

B Contains items marked (A)
 Comprend les pièces marquées (A)
 Incluye las piezas marcadas (A)



820
 TX760B

805 806 807 808 833 834

76030C06.1

6199042M3

1

Jan-06

Digger Hydraulics
Circuit Hydraulique Défonceuse
Circuito hidráulico equipo retro

Sideshift
Montage de Pelle Latéral
Excavadora de montaje horizontal

Swing Components
Organes de Rotation
Componentes de rotación

Std. Spec.
 Std. Spec.
 Std. Spec.

C-76030-07.1-A

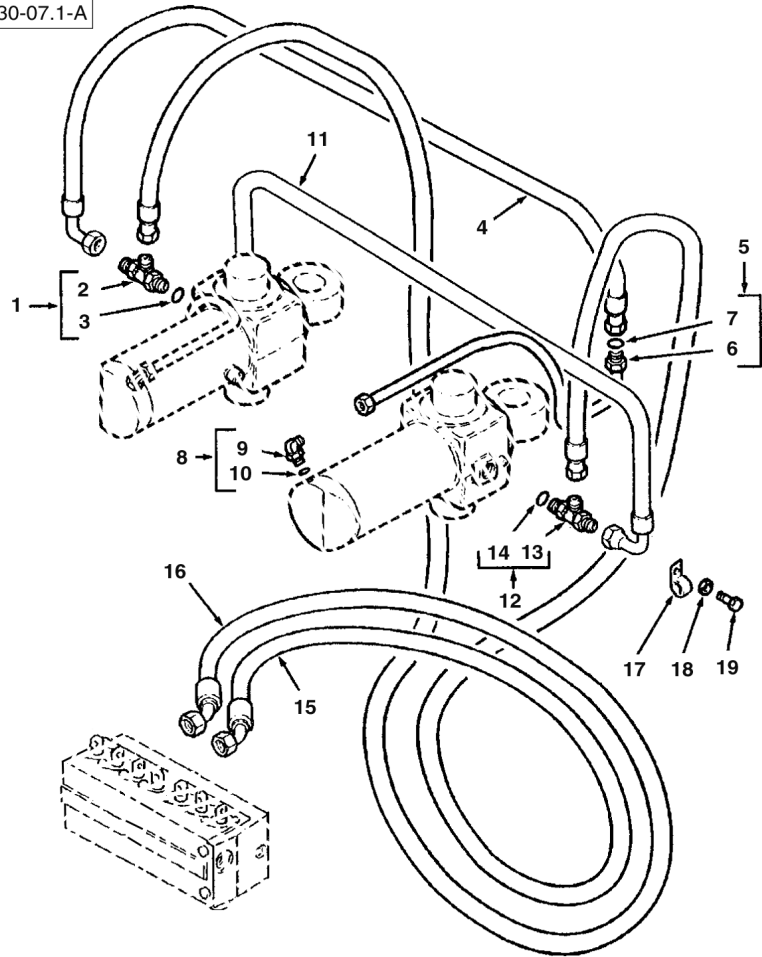

1	358728X91		1	Tee	Raccord en T	Te
2		1	▶ Ref. 1	1	Tee	Raccord en T
3	831497M1	1		1	O-Ring	Joint torique
4	6100716M91	840 mm		1	Hose Assy	Ensemble de flexible
5	6100587M91	◀		1	Tube Assy	Tuyauterie
5	6100589M91	▶		1	Tube Assy	Tuyauterie
6		5	▶ Ref. 5	1	Tube	Tube
7	394923X1	5		1	O-Ring	Joint torique
8	357197X91			2	Elbow, 90°	Coude à 90°
9		8	▶ Ref. 8	1	Elbow	Coude
10	831452M1	8		1	O-Ring	Joint torique
11	6100716M91	840 mm		1	Hose Assy	Ensemble de flexible
12	358728X91			1	Tee	Raccord en T
13		12	▶ Ref. 12	1	Tee	Raccord en T
14	831497M1	12		1	O-Ring	Joint torique
15	6107456M91	◀ 1745 mm		1	Hose Assy	Ensemble de flexible
16	6107455M91	▶ 1745 mm		1	Hose Assy	Ensemble de flexible
17	3517114M2			2	Clip, Mounting	Collier de fixation
18	385361X1	M8		2	Washer	Rondelle
19	339228X1	M8 x 12		2	Screw	Vis



820
TX760B

805 806 807 808 833 834

76030C07.1

6199042M3

1

Jan-06

Digger Hydraulics
 Circuit Hydraulique Défonceuse
 Circuito hidráulico equipo retro

Sideshift
 Montage de Pelle Latéral
 Excavadora de montaje horizontal

Clamp
 Collier
 Abrazadera

Std. Spec.
 Std. Spec.
 Std. Spec.

C-76030-08.1-A

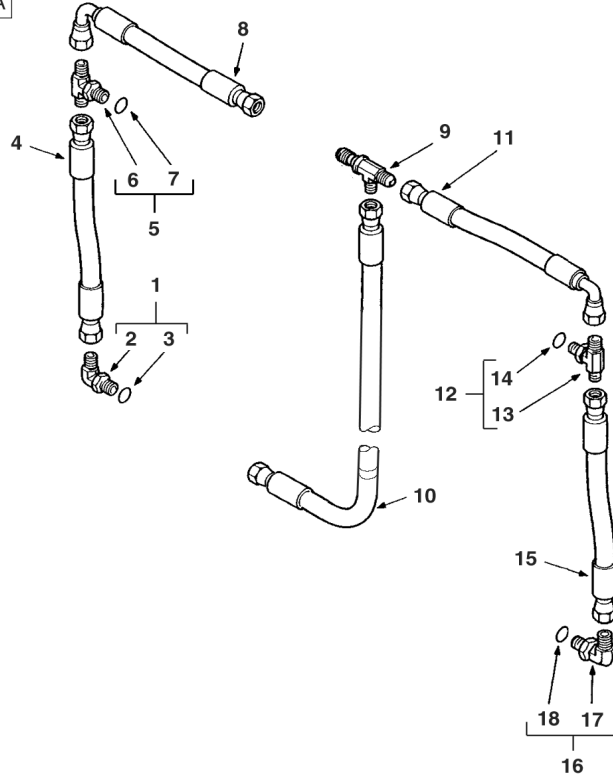

1	358761X91			1	Elbow, 90°	Coude à 90°	Codo, 90°
2		1	▶ Ref. 1	1	Elbow	Coude	Codo
3	831496M1	1		1	O-Ring	Joint torique	Junta de tipo O
4	3521882M94			1	Hose Assy	Ensemble de flexible	Flexible, Conj.
5	358827X91			1	Tee	Raccord en T	Te
6		5	▶ Ref. 5	1	Tee	Raccord en T	Te
7	831496M1	5		1	O-Ring	Joint torique	Junta de tipo O
8	3521878M93			1	Hose Assy	Ensemble de flexible	Flexible, Conj.
9	356558X1			1	Tee	Raccord en T	Te
10	6110207M91	Clamp		1	Hose Assy	Ensemble de flexible	Flexible, Conj.
11	3521878M93			1	Hose Assy	Ensemble de flexible	Flexible, Conj.
12	358827X91			1	Tee	Raccord en T	Te
13		12	▶ Ref. 12	1	Tee	Raccord en T	Te
14	831496M1	12		1	O-Ring	Joint torique	Junta de tipo O
15	3521882M94			1	Hose Assy	Ensemble de flexible	Flexible, Conj.
16	358761X91			1	Elbow, 90°	Coude à 90°	Codo, 90°
17		16	▶ Ref. 16	1	Elbow	Coude	Codo
18	831496M1	16		1	O-Ring	Joint torique	Junta de tipo O



820
 TX760B

805 806 807 808 833 834

76030C08.1

6199042M3

1

Jan-06

Digger Hydraulics
Circuit Hydraulique Défonceuse
Circuito hidráulico equipo retro

Sideshift
Montage de Pelle Latéral
Excavadora de montaje horizontal

Attachment
Attache
Equipo

C-76030-09.1-A

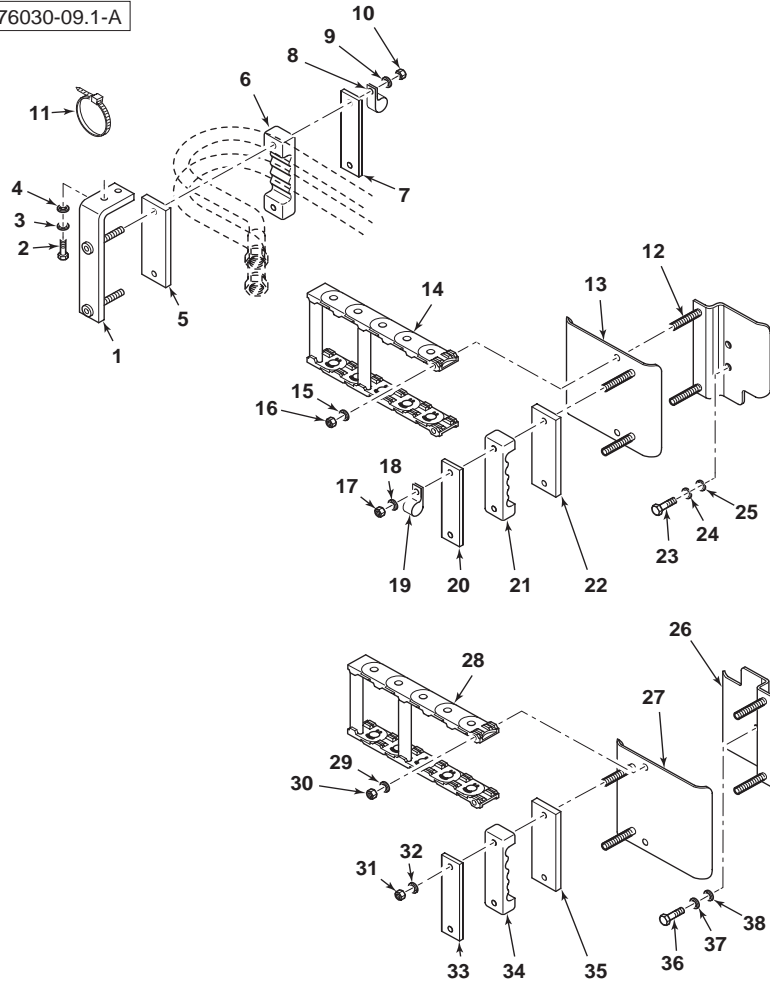

1	6107934M91		2	Bracket, Clamp	Bride de fixation	Brida de fijación
2	339761X1	M8 x 25	4	Screw	Vis	Tornillo
3	390972X1	M8	4	Washer	Rondelle	Arandela
4	339374X1	M8	4	Washer, Lock	Rondelle de blocage	Arandela de freno
5	6102197M1		2	Pad, Rubber	Plaque de caoutchouc	Placa, Caucho
6	6101216M1	◀	1	Clamp	Collier de serrage	Argolla de cierre
6	6101859M1	▶	1	Clamp	Collier de serrage	Argolla de cierre
7	6101215M1		2	Plate	Plaque	Placa
8	515-22159		1	Clip, Mounting	Collier de fixation	Argolla de fijación
9	390972X1	M8	4	Washer	Rondelle	Arandela
10	394367X1	M8	4	Nut, Lock	Écrou de blocage	Tuerca de retención
11	1862425M1		1	Tie, Cable	Attache câble	Enlace de Cable
12	6102307M91	▶	1	Bracket, Clamp	Bride de fixation	Brida de fijación
13	6101424M91		1	Plate Assy	Ensemble de plaque	Placa, Conj.
14	6102199M92		1	Chain	Chaîne	Cadena
15	390971X1	M6	2	Washer	Rondelle	Arandela
16	1441500X1	M6	2	Nut, Lock	Écrou de blocage	Tuerca de retención
17	394367X1	M8	2	Nut, Lock	Écrou de blocage	Tuerca de retención
18	390972X1	M8	2	Washer	Rondelle	Arandela
19	515-22159		1	Clip, Mounting	Collier de fixation	Argolla de fijación
20	6101215M1		1	Plate	Plaque	Placa
21	6101859M1		1	Clamp	Collier de serrage	Argolla de cierre
22	6102197M1		1	Pad, Rubber	Plaque de caoutchouc	Placa, Caucho
23	3009492X1	M10 x 25	2	Screw	Vis	Tornillo
24	339376X1	M10	2	Washer, Lock	Rondelle de blocage	Arandela de freno
25	390734X1	M10	2	Washer	Rondelle	Arandela
26	6102308M91	◀	1	Bracket, Clamp	Bride de fixation	Brida de fijación
27	6101424M91		1	Plate Assy	Ensemble de plaque	Placa, Conj.
28	6102199M92		1	Chain	Chaîne	Cadena
29	390971X1	M6	2	Washer	Rondelle	Arandela
30	1441500X1	M6	2	Nut, Lock	Écrou de blocage	Tuerca de retención
31	394367X1	M8	2	Nut, Lock	Écrou de blocage	Tuerca de retención
32	390972X1	M8	2	Washer	Rondelle	Arandela
33	6101215M1		1	Plate	Plaque	Placa
34	6101216M1	◀	1	Clamp	Collier de serrage	Argolla de cierre
35	6102197M1		1	Pad, Rubber	Plaque de caoutchouc	Placa, Caucho
36	3009492X1	M10 x 25	2	Screw	Vis	Tornillo
37	339376X1	M10	2	Washer, Lock	Rondelle de blocage	Arandela de freno
38	390734X1	M10	2	Washer	Rondelle	Arandela



820
TX760B

805 806 807 808 833 834

76030C09.1

6199042M3

1

Jan-06

Digger Hydraulics
Circuit Hydraulique Défonceuse
Circuito hidráulico equipo retro

Sideshift
Montage de Pelle Latéral
Excavadora de montaje horizontal

Bucket
 Godet
 Cuchara

Std. Spec.
 Std. Spec.
 Std. Spec.

C-76031-01.1-A

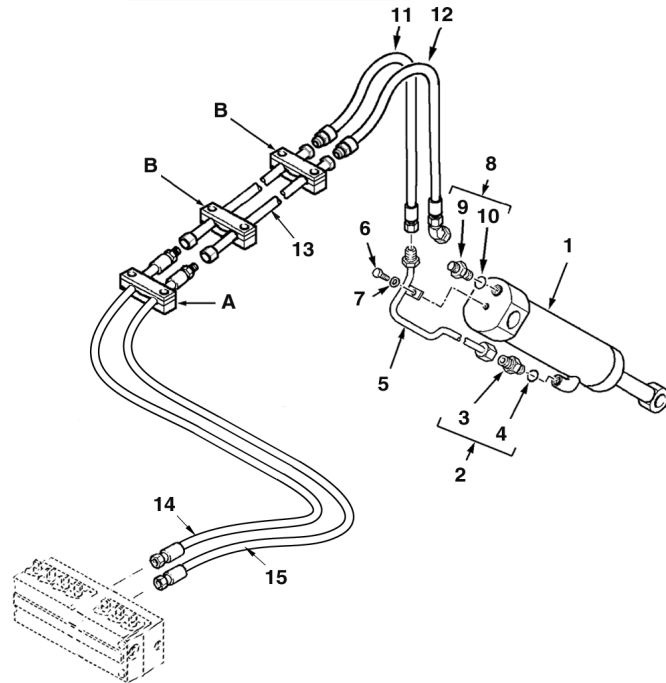
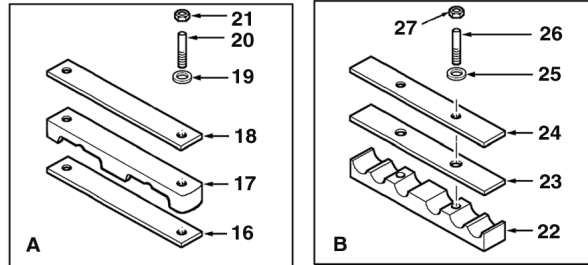

1	5000126M91	76031C02.1	1	Cylinder Assy	Ensemble de vérin	Gato, Conj.
2	835013M91		1	Connector Assy	Ensemble connexion	Conexión, Conj.
3		2 Ref. 2	1	Union	Union	Unión
4	835024M1	2	1	O-Ring	Joint torique	Junta de tipo O
5	6101540M91		1	Tube Assy	Tuyauterie	Conjunto de tubería
6	339123X1	M8 x 20	1	Bolt	Boulon	Perno
7	385361X1	M8	1	Washer	Rondelle	Arandela
8	835013M91		1	Connector Assy	Ensemble connexion	Conexión, Conj.
9		8 Ref. 8	1	Union	Union	Unión
10	835024M1	8	1	O-Ring	Joint torique	Junta de tipo O
11		(A)Brown	1	Hose Assy	Ensemble de flexible	Flexible, Conj.
12		(A)White	1	Hose Assy	Ensemble de flexible	Flexible, Conj.
13	6101771M91		2	Tube Assy	Tuyauterie	Conjunto de tubería
14	6108762M91	Brown	1	Hose Assy	Ensemble de flexible	Flexible, Conj.
15	6108763M91	White	1	Hose Assy	Ensemble de flexible	Flexible, Conj.
16	6102128M1		1	Pad	Plaque antidérapante	Cinta antideslizante
17	6102122M1		1	Bracket, Clamp	Bride de fixation	Brida de fijación
18	6102130M1		1	Plate	Plaque	Placa
19	390972X1	M8	2	Washer	Rondelle	Arandela
20	3516075M1	M8 x 65	2	Stud	Goujon	Espárrago
21	394367X1	M8	2	Nut, Lock	Écrou de blocage	Tuerca de retención
22	6102126M1		2	Bracket, Clamp	Bride de fixation	Brida de fijación
23	6102145M1		2	Pad	Plaque antidérapante	Cinta antideslizante
24	6102124M1		2	Plate	Plaque	Placa
25	390972X1	M8	4	Washer	Rondelle	Arandela
26	6108049M1		4	Stud	Goujon	Espárrago
27	394367X1	M8	4	Nut, Lock	Écrou de blocage	Tuerca de retención

A See extendahoe hydraulics section
 Voir la section circuit hydraulique extendahoe
 Ver la sección de la circuito hidráulico extendahoe



820
 TX760B

805 806 807 808 833 834

76031C01.1

6199042M3

1

Jan-06

Digger Hydraulics
Circuit Hydraulique Défonceuse
Circuito hidráulico equipo retro

Sideshift
Montage de Pelle Latéral
Excavadora de montaje horizontal

Bucket Cylinder
Vérin de Godet
Gato de cuchara

Std. Spec.
 Std. Spec.
 Std. Spec.

C-76031-02.1-A

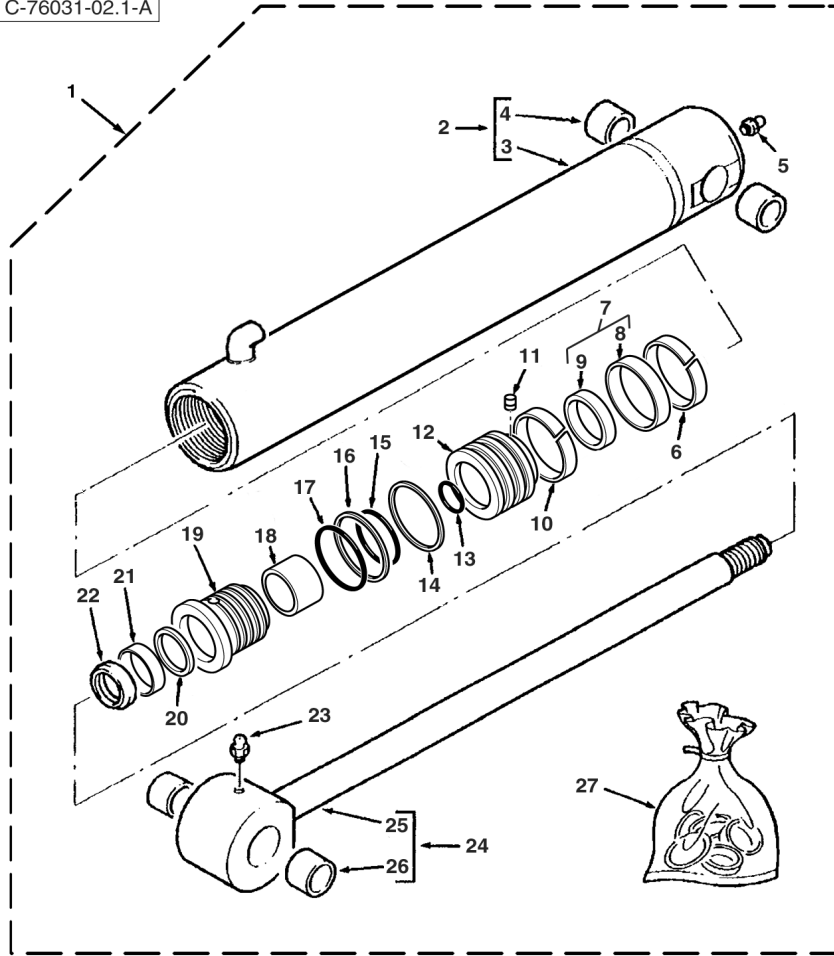

1	5000126M91		76031C01.1	1	Cylinder Assy	Ensemble de vérin	Gato, Conj.
2	5004008M91	1		1	Cylinder	Cylindre	Cilindro
3		3	Ref. 2	1	Tube, Cylinder	Cylindre de vérin	Cilindro de gato
4		3 (C)		1	Bushing	Bague	Anillo
5	339608X1	1		1	Fitting, Grease	Graisser	Engrasador
6	3485892M1	1 (A)		1	Ring, Sealing	Bague d'étanchéité	Anillo, Estanqueidad
7	3485245M91	1 (A)		1	Seal Assy	Ensemble de joint	Junta, Conj.
8		7	Ref. 7	1	Seal	Joint	Junta
9		7	Ref. 7	1	Ring	Anneau	Aro
10	3485892M1	1 (A)		1	Ring, Sealing	Bague d'étanchéité	Anillo, Estanqueidad
11	3402928M1	1		1	Screw	Vis	Tornillo
12	3623372M1	1		1	Piston	Piston	Pistón
13	359186X1	1 (A)		1	O-Ring	Joint torique	Junta de tipo O
14	3623061M1	1		1	Ring, Piston	Segment de piston	Segmento de pistón
15	359193X1	1 (A)		1	O-Ring	Joint torique	Junta de tipo O
16	1606735M1	1 (A)		1	Ring, Backup	Contre-joint	ContraJunta
17	3487207M1	1 (A)		1	O-Ring	Joint torique	Junta de tipo O
18	3484615M1	1 (A)		1	Ring	Anneau	Aro
19	3623371M1	1		1	Bearing	Coussinet	Cojinete
20	3484055M1	1 (A)		1	Ring	Anneau	Aro
21	3485185M1	1 (A)		1	Seal	Joint	Junta
22	3487015M1	1 (A)		1	Ring	Anneau	Aro
23	339608X1	1		1	Fitting, Grease	Graisser	Engrasador
24	5004012M91	1		1	Rod, Piston	Tige de vérin	Vástago cilindro
25		24	Ref. 24	1	Rod, Piston	Tige de vérin	Vástago cilindro
26		24 (C)		1	Bushing	Bague	Anillo
27	3623373M91		(B)	1	Kit, Seal	Pochette de joints	Juego de juntas

A Contains items marked (A)
 Comprend les pièces marquées (A)
 Incluye las piezas marcadas (A)
 C Part number to be advised
 Référence pièce à demander
 Indicar número de pieza

B Included in kit marked (B)
 Inclus dans jeu marqué (B)
 Incluido en juego marcado (B)



820
 TX760B

805 806 807 808 833 834

76031C02.1

6199042M3

1

Jan-06

Digger Hydraulics
Circuit Hydraulique Défonceuse
Circuito hidráulico equipo retro

Sideshift
Montage de Pelle Latéral
Excavadora de montaje horizontal

Telescopic Dipper
Balancier Téléscopique
Balancín telescópico

Std. Spec.
 Std. Spec.
 Std. Spec.

C-76031-03.1-A

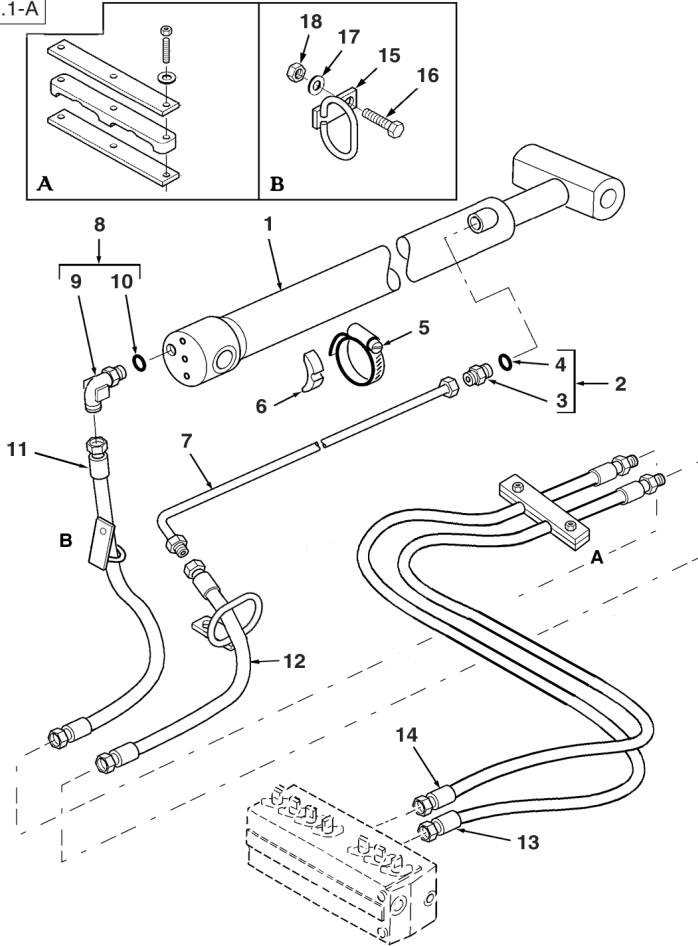

1	5000124M91	76031C04.1	1	Cylinder Assy	Ensemble de vérin	Gato, Conj.
2	835013M91		1	Connector Assy	Ensemble connexion	Conexión, Conj.
3		2	1	Union	Union	Unión
4	835024M1	2	1	O-Ring	Joint torique	Junta de tipo O
5	3517733M1		1	Clamp	Collier de serrage	Argolla de cierre
6	L79937		1	Spacer	Entretoise	Travesa
7	6100976M92	(A)	1	Tube Assy	Tuyauterie	Conjunto de tubería
8	6101624M91	(A)	1	Elbow, 90°	Coude à 90°	Codo, 90°
9		8	1	Elbow	Coude	Codo
10	835024M1	8	1	O-Ring	Joint torique	Junta de tipo O
11	6101738M91	Yellow	1	Hose Assy	Ensemble de flexible	Flexible, Conj.
12	6101737M91	Red	1	Hose Assy	Ensemble de flexible	Flexible, Conj.
13	6108767M91	Yellow	1	Hose Assy	Ensemble de flexible	Flexible, Conj.
14	6108766M91	Red	1	Hose Assy	Ensemble de flexible	Flexible, Conj.
15	6101491M92		2	Support Assy	Ensemble de support	Apoyadero, Conj.
16	339761X1	M8 x 25	2	Screw	Vis	Tornillo
17	390972X1	M8	2	Washer	Rondelle	Arandela
18	394367X1	M8	2	Nut, Lock	Écrou de blocage	Tuerca de retención

A Without Hose Burst
 Sans éclatement de tuyau
 Sin rotura de tubo flexible



820
 TX760B

805 806 807 808 833 834

76031C03.1

6199042M3

1

Jan-06

Digger Hydraulics
Circuit Hydraulique Défonceuse
Circuito hidráulico equipo retro

Sideshift
Montage de Pelle Latéral
Excavadora de montaje horizontal

Dipper Cylinder
Vérin de Balancier
Gato de balancín

Std. Spec.
 Std. Spec.
 Std. Spec.

C-76031-04.1-A

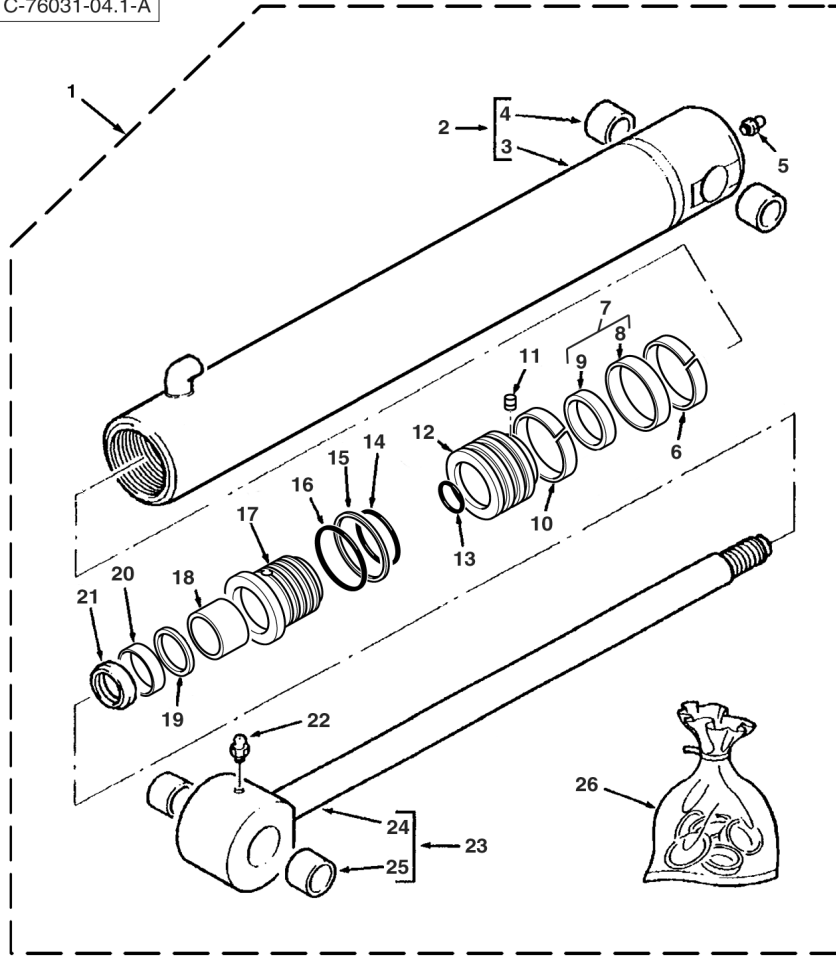

1	5000124M91	76031C03.1	1	Cylinder Assy	Ensemble de vérin	Gato, Conj.
2	5003982M91		1	Cylinder	Cylindre	Cilindro
3		Ref. 2	1	Tube, Cylinder	Cylindre de vérin	Cilindro de gato
4	3484843M1		2	Bush	Bague	Casquillo
5	339608X1		1	Fitting, Grease	Graisneur	Engrasador
6	3485891M1	(A)	1	Ring	Anneau	Aro
7	3485247M91	(A)	1	Seal Assy	Ensemble de joint	Junta, Conj.
8		Ref. 7	1	Seal	Joint	Junta
9		Ref. 7	1	Ring	Anneau	Aro
10	3485891M1	(A)	1	Ring	Anneau	Aro
11	3402928M1		1	Screw	Vis	Tornillo
12	5003989M1		1	Piston	Piston	Pistón
13	3007182X1	(A)	1	O-Ring	Joint torique	Junta de tipo O
14	359196X1	(A)	1	O-Ring	Joint torique	Junta de tipo O
15	378545X1	(A)	1	Ring	Anneau	Aro
16	3487908M1	(A)	1	O-Ring	Joint torique	Junta de tipo O
17	5003988M1		1	Bearing	Coussinet	Cojinete
18	3623193M1	(A)	1	Ring	Anneau	Aro
19	3443388M1	(A)	1	Ring	Anneau	Aro
20	3443472M1	(A)	1	Seal	Joint	Junta
21	3403385M1	(A)	1	Ring, Wiper	Joint de racler	Junta raspador
22	339608X1		1	Fitting, Grease	Graisneur	Engrasador
23	5003985M91		1	Rod, Piston	Tige de vérin	Vástago cilindro
24		Ref. 23	1	Rod, Piston	Tige de vérin	Vástago cilindro
25	3484843M1		23	Bush	Bague	Casquillo
26	5004401M91	(B)	1	Kit, Seal	Pochette de joints	Juego de juntas

A Included in kit marked (B)
 Inclus dans jeu marqué (B)
 Incluido en juego marcado (B)

B Contains items marked (A)
 Comprend les pièces marquées (A)
 Incluye las piezas marcadas (A)



820
 TX760B

805 806 807 808 833 834

76031C04.1

6199042M3

1

Jan-06

Digger Hydraulics
Circuit Hydraulique Défonceuse
Circuito hidráulico equipo retro

Sideshift
Montage de Pelle Latéral
Excavadora de montaje horizontal

Boom
 Flèche
 Pluma

Std. Spec.
 Std. Spec.
 Std. Spec.

C-76031-05.1-A

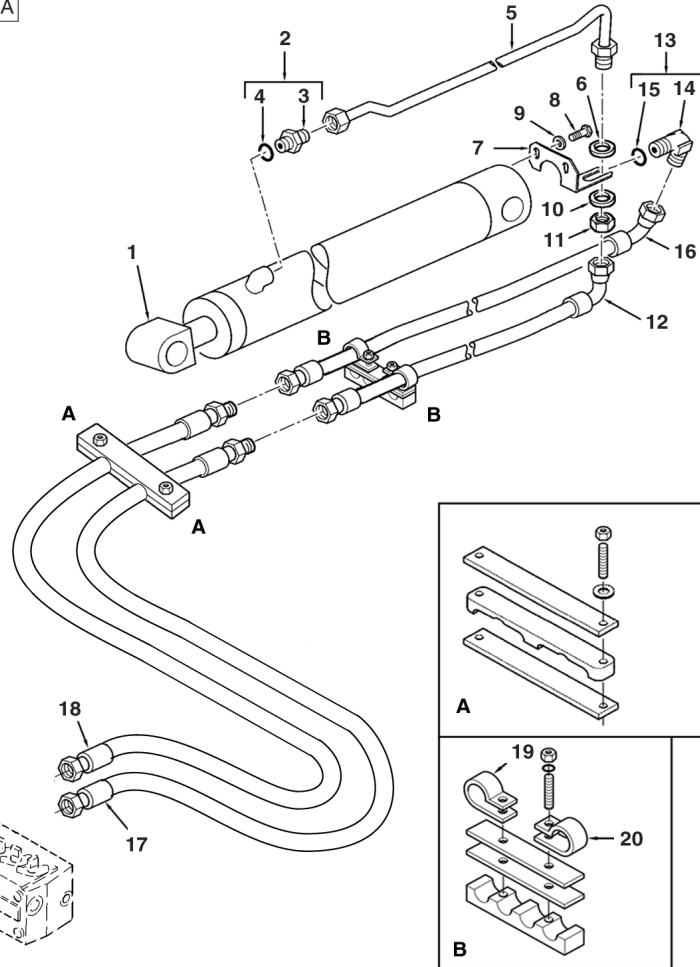

1	5000121M91	76031C06.1	1	Cylinder Assy	Ensemble de vérin	Gato, Conj.
2	835013M91		1	Connector Assy	Ensemble connexion	Conexión, Conj.
3		2	1	Union	Union	Unión
4	835024M1	2	1	O-Ring	Joint torique	Junta de tipo O
5	6100855M91	(A)	1	Tube Assy	Tuyauterie	Conjunto de tubería
6	353763X1	(A)	1	Washer	Rondelle	Arandela
7	6100883M1	(A)	1	Bracket	Patte de fixation	Pata de fijación
8	339228X1	M8 x 12	2	Screw	Vis	Tornillo
9	339374X1	M8	2	Washer, Lock	Rondelle de blocage	Arandela de freno
10	353763X1	(A)	1	Washer	Rondelle	Arandela
11	355574X1	(A)	1	Nut	Écrou	Tuerca
12	6101735M92	(A) Orange	1	Hose Assy	Ensemble de flexible	Flexible, Conj.
13	835007M91	(A)	1	Elbow, 90°	Coude à 90°	Codo, 90°
14		13	1	Elbow	Coude	Codo
15	835024M1	13	1	O-Ring	Joint torique	Junta de tipo O
16	6101736M92	Blue	1	Hose Assy	Ensemble de flexible	Flexible, Conj.
17	6108761M91	Orange	1	Hose Assy	Ensemble de flexible	Flexible, Conj.
18	6108760M91	Blue	1	Hose Assy	Ensemble de flexible	Flexible, Conj.
19	515-23270		1	Clip	Clip	Clip
20	515-23206		1	Clip	Clip	Clip

A Without Hose Burst
 Sans éclatement de tuyau
 Sin rotura de tubo flexible



820
 TX760B

805 806 807 808 833 834

76031C05.1

6199042M3

1

Jan-06

Digger Hydraulics
Circuit Hydraulique Défonceuse
Circuito hidráulico equipo retro

Sideshift
Montage de Pelle Latéral
Excavadora de montaje horizontal

Boom Cylinder
Vérin de Flèche
Gato de pluma

Std. Spec.
 Std. Spec.
 Std. Spec.

C-76031-06.1-A

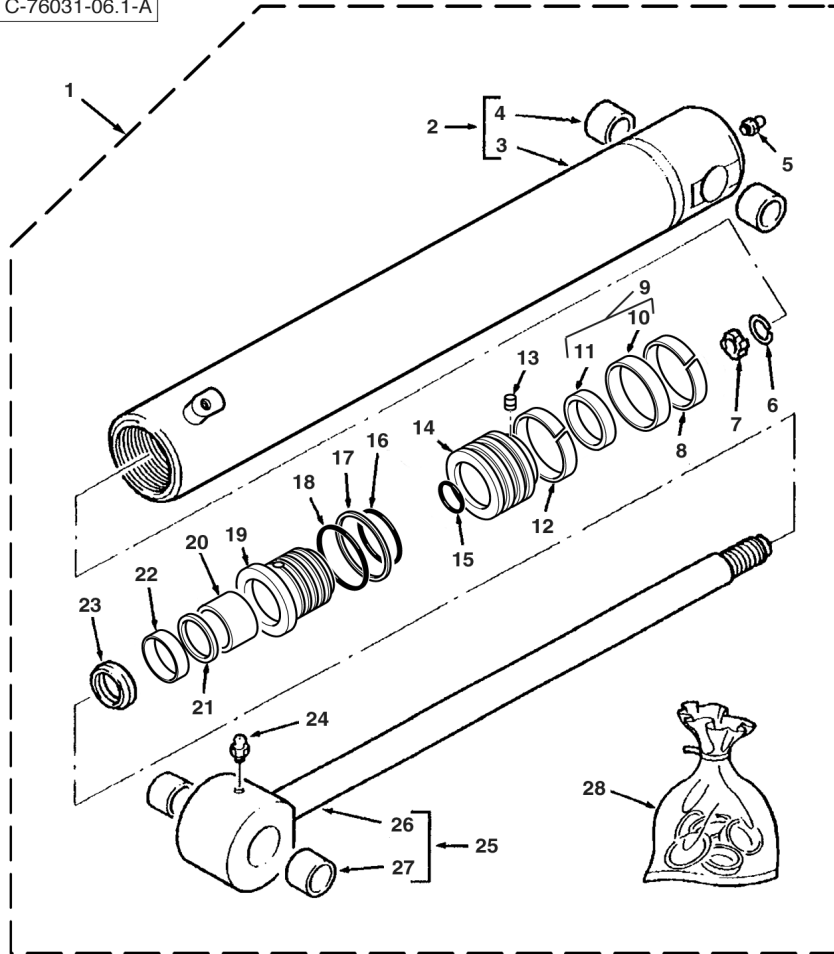

1	5000121M91	76031C05.1	1	Cylinder Assy	Ensemble de vérin	Gato, Conj.
2	5003974M91		1	Cylinder	Cylindre	Cilindro
3		2	Ref. 2	Tube, Cylinder	Cylindre de vérin	Cilindro de gato
4		2 (C)		Bushing	Bague	Anillo
5	339608X1	1		Fitting, Grease	Graisneur	Engrasador
6	1609899M1	1		Ring, Snap	Anneau d'arrêt	Anillo de resorte
7	1609328M1	1		Ring	Anneau	Aro
8	3442376M1	1 (A)	2	Ring	Anneau	Aro
9	3485249M91	1 (A)	1	Seal	Joint	Junta
10		9	Ref. 9	Seal	Joint	Junta
11		9	Ref. 9	Seal	Joint	Junta
13	3402928M1	1		Screw	Vis	Tornillo
14	5003980M1	1		Piston	Piston	Pistón
15	3007182X1	1 (A)	1	O-Ring	Joint torique	Junta de tipo O
16	359201X1	1 (A)	1	O-Ring	Joint torique	Junta de tipo O
17	1024334M1	1 (A)	1	Ring	Anneau	Aro
18	3487909M1	1 (A)	1	O-Ring	Joint torique	Junta de tipo O
19	5003979M1	1	1	Bearing	Coussinet	Cojinete
20	3623193M1	1 (A)	1	Ring	Anneau	Aro
21	3443388M1	1 (A)	1	Ring	Anneau	Aro
22	3443472M1	1 (A)	1	Seal	Joint	Junta
23	3403385M1	1 (A)	1	Ring, Wiper	Joint de racleur	Junta raspador
24	339608X1	1	1	Fitting, Grease	Graisneur	Engrasador
25	3441629M91	1	1	Rod, Piston	Tige de vérin	Vástago cilindro
26		25	Ref. 25	Rod, Piston	Tige de vérin	Vástago cilindro
27	3484843M1	25	Ref. 26	Bush	Bague	Casquillo
28	5004400M91	(B)	1	Kit, Seal	Pochette de joints	Juego de juntas

A Included in kit marked (B)
 Inclus dans jeu marqué (B)
 Incluido en juego marcado (B)

C Part number to be advised
 Référence pièce à demander
 Indicar número de pieza

B Contains items marked (A)
 Comprend les pièces marquées (A)
 Incluye las piezas marcadas (A)



820
 TX760B

805 806 807 808 833 834

76031C06.1

6199042M3

1

Jan-06

Digger Hydraulics
Circuit Hydraulique Défonceuse
Circuito hidráulico equipo retro

Sideshift
Montage de Pelle Latéral
Excavadora de montaje horizontal

Swing Components
Organes de Rotation
Componentes de rotación

Std. Spec.
 Std. Spec.
 Std. Spec.

C-76031-07.1-A

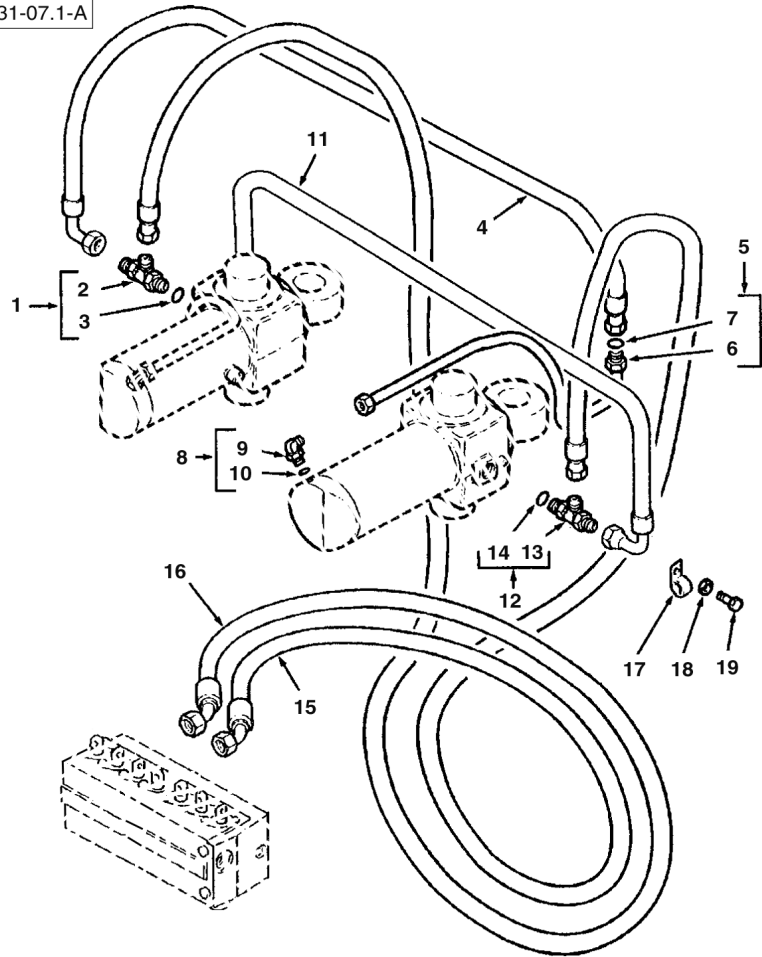

1	358728X91			1	Tee	Raccord en T	Te
2		1	▶ Ref. 1	1	Tee	Raccord en T	Te
3	831497M1	1		1	O-Ring	Joint torique	Junta de tipo O
4	6100716M91	840 mm		1	Hose Assy	Ensemble de flexible	Flexible, Conj.
5	6100587M91		◀	1	Tube Assy	Tuyauterie	Conjunto de tubería
5	6100589M91		▶	1	Tube Assy	Tuyauterie	Conjunto de tubería
6		5	▶ Ref. 5	1	Tube	Tube	Tubo
7	394923X1	5		1	O-Ring	Joint torique	Junta de tipo O
8	357197X91			2	Elbow, 90°	Coude à 90°	Codo, 90°
9		8	▶ Ref. 8	1	Elbow	Coude	Codo
10	831452M1	8		1	O-Ring	Joint torique	Junta de tipo O
11	6100716M91	840 mm		1	Hose Assy	Ensemble de flexible	Flexible, Conj.
12	358728X91			1	Tee	Raccord en T	Te
13		12	▶ Ref. 12	1	Tee	Raccord en T	Te
14	831497M1	12		1	O-Ring	Joint torique	Junta de tipo O
15	6107456M91		◀ 1745 mm	1	Hose Assy	Ensemble de flexible	Flexible, Conj.
16	6107455M91		▶ 1745 mm	1	Hose Assy	Ensemble de flexible	Flexible, Conj.
17	3517114M2			2	Clip, Mounting	Collier de fixation	Argolla de fijación
18	385361X1	M8		2	Washer	Rondelle	Arandela
19	339228X1	M8 x 12		2	Screw	Vis	Tornillo



820
TX760B

805 806 807 808 833 834

76031C07.1

6199042M3

1

Jan-06

Digger Hydraulics
 Circuit Hydraulique Défonceuse
 Circuito hidráulico equipo retro

Sideshift
 Montage de Pelle Latéral
 Excavadora de montaje horizontal

Clamp
 Collier
 Abrazadera

Std. Spec.
 Std. Spec.
 Std. Spec.

C-76031-08.1-A

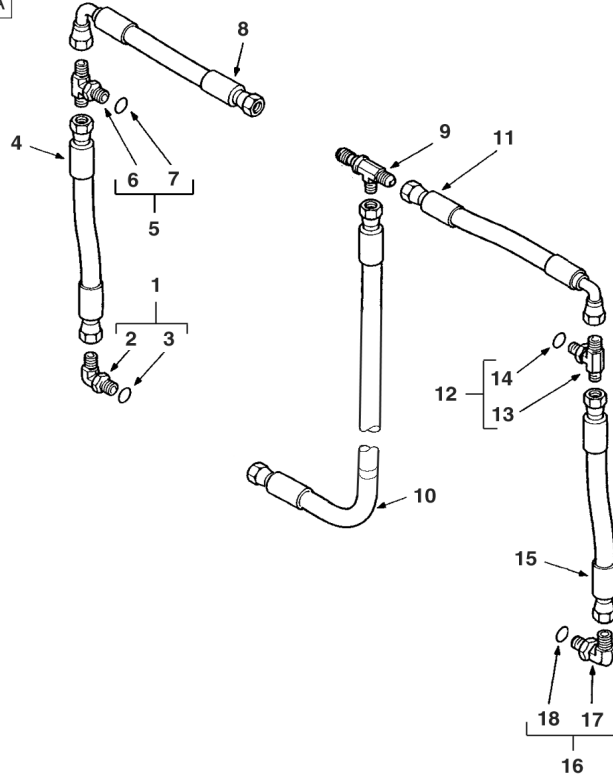

1	358761X91			1	Elbow, 90°	Coude à 90°	Codo, 90°
2		1	▶ Ref. 1	1	Elbow	Coude	Codo
3	831496M1	1		1	O-Ring	Joint torique	Junta de tipo O
4	3521882M94			1	Hose Assy	Ensemble de flexible	Flexible, Conj.
5	358827X91			1	Tee	Raccord en T	Te
6		5	▶ Ref. 5	1	Tee	Raccord en T	Te
7	831496M1	5		1	O-Ring	Joint torique	Junta de tipo O
8	3521878M93			1	Hose Assy	Ensemble de flexible	Flexible, Conj.
9	356558X1			1	Tee	Raccord en T	Te
10	6110207M91	Clamp		1	Hose Assy	Ensemble de flexible	Flexible, Conj.
11	3521878M93			1	Hose Assy	Ensemble de flexible	Flexible, Conj.
12	358827X91			1	Tee	Raccord en T	Te
13		12	▶ Ref. 12	1	Tee	Raccord en T	Te
14	831496M1	12		1	O-Ring	Joint torique	Junta de tipo O
15	3521882M94			1	Hose Assy	Ensemble de flexible	Flexible, Conj.
16	358761X91			1	Elbow, 90°	Coude à 90°	Codo, 90°
17		16	▶ Ref. 16	1	Elbow	Coude	Codo
18	831496M1	16		1	O-Ring	Joint torique	Junta de tipo O



820
 TX760B

805 806 807 808 833 834

76031C08.1

6199042M3

1

Jan-06

Digger Hydraulics
Circuit Hydraulique Défonceuse
Circuito hidráulico equipo retro

Sideshift
Montage de Pelle Latéral
Excavadora de montaje horizontal

Attachment
Attache
Equipo

C-76031-09.1-A

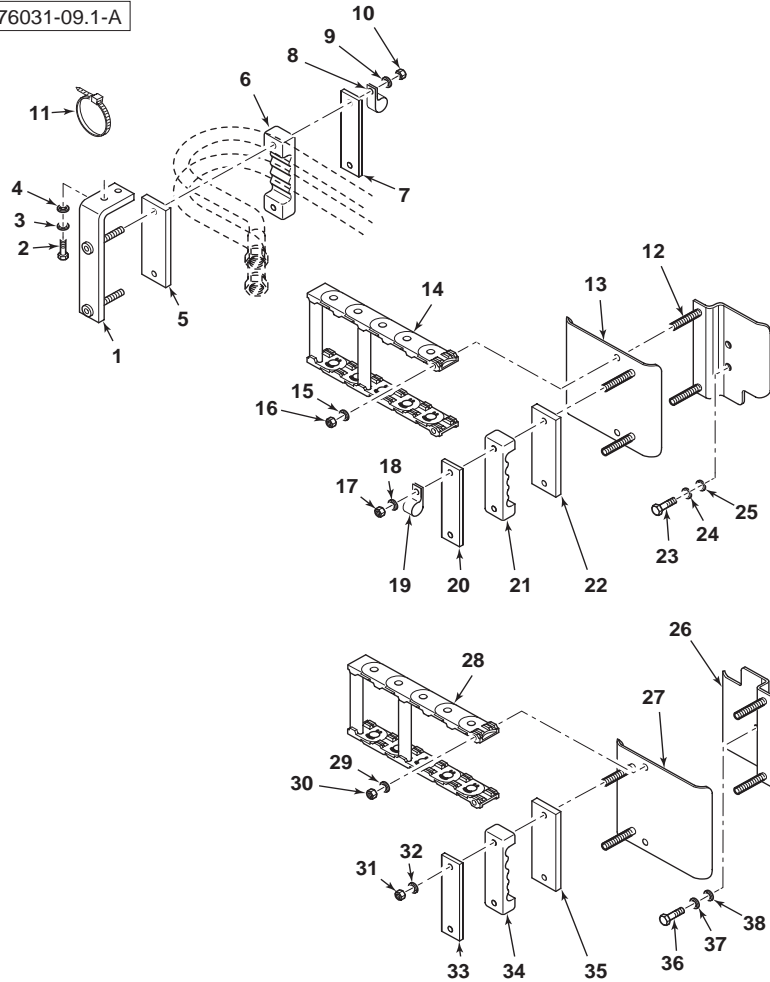

1	6107934M91		2	Bracket, Clamp	Bride de fixation	Brida de fijación
2	339761X1	M8 x 25	4	Screw	Vis	Tornillo
3	390972X1	M8	4	Washer	Rondelle	Arandela
4	339374X1	M8	4	Washer, Lock	Rondelle de blocage	Arandela de freno
5	6102197M1		2	Pad, Rubber	Plaque de caoutchouc	Placa, Caucho
6	6101216M1	◀	1	Clamp	Collier de serrage	Argolla de cierre
6	6101859M1	▶	1	Clamp	Collier de serrage	Argolla de cierre
7	6101215M1		2	Plate	Plaque	Placa
8	515-22159		1	Clip, Mounting	Collier de fixation	Argolla de fijación
9	390972X1	M8	4	Washer	Rondelle	Arandela
10	394367X1	M8	4	Nut, Lock	Écrou de blocage	Tuerca de retención
11	1862425M1		1	Tie, Cable	Attache câble	Enlace de Cable
12	6102307M91	▶	1	Bracket, Clamp	Bride de fixation	Brida de fijación
13	6101424M91		1	Plate Assy	Ensemble de plaque	Placa, Conj.
14	6102199M92		1	Chain	Chaîne	Cadena
15	390971X1	M6	2	Washer	Rondelle	Arandela
16	1441500X1	M6	2	Nut, Lock	Écrou de blocage	Tuerca de retención
17	394367X1	M8	2	Nut, Lock	Écrou de blocage	Tuerca de retención
18	390972X1	M8	2	Washer	Rondelle	Arandela
19	515-22159		1	Clip, Mounting	Collier de fixation	Argolla de fijación
20	6101215M1		1	Plate	Plaque	Placa
21	6101859M1		1	Clamp	Collier de serrage	Argolla de cierre
22	6102197M1		1	Pad, Rubber	Plaque de caoutchouc	Placa, Caucho
23	3009492X1	M10 x 25	2	Screw	Vis	Tornillo
24	339376X1	M10	2	Washer, Lock	Rondelle de blocage	Arandela de freno
25	390734X1	M10	2	Washer	Rondelle	Arandela
26	6102308M91	◀	1	Bracket, Clamp	Bride de fixation	Brida de fijación
27	6101424M91		1	Plate Assy	Ensemble de plaque	Placa, Conj.
28	6102199M92		1	Chain	Chaîne	Cadena
29	390971X1	M6	2	Washer	Rondelle	Arandela
30	1441500X1	M6	2	Nut, Lock	Écrou de blocage	Tuerca de retención
31	394367X1	M8	2	Nut, Lock	Écrou de blocage	Tuerca de retención
32	390972X1	M8	2	Washer	Rondelle	Arandela
33	6101215M1		1	Plate	Plaque	Placa
34	6101216M1	◀	1	Clamp	Collier de serrage	Argolla de cierre
35	6102197M1		1	Pad, Rubber	Plaque de caoutchouc	Placa, Caucho
36	3009492X1	M10 x 25	2	Screw	Vis	Tornillo
37	339376X1	M10	2	Washer, Lock	Rondelle de blocage	Arandela de freno
38	390734X1	M10	2	Washer	Rondelle	Arandela



820
TX760B

805 806 807 808 833 834

76031C09.1

6199042M3

1

Jan-06

Digger Hydraulics
Circuit Hydraulique Défonceuse
Circuito hidráulico equipo retro

Sideshift
Montage de Pelle Latéral
Excavadora de montaje horizontal

Bucket
 Godet
 Cuchara

High Spec.
 High Spec.
 High Spec.

C-76032-01.1-A

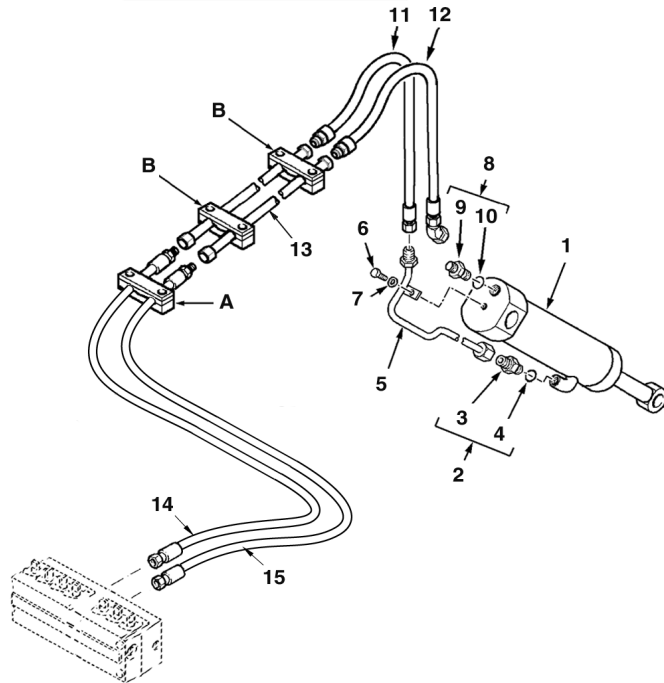
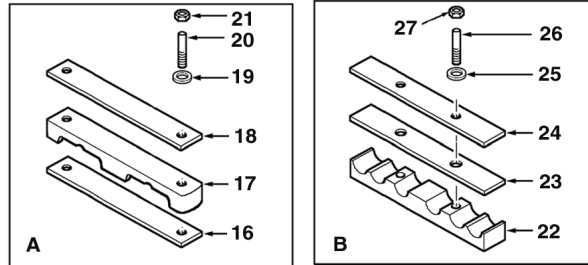

1	5000126M91	76032C02.1	1	Cylinder Assy	Ensemble de vérin	Gato, Conj.
2	835013M91		1	Connector Assy	Ensemble connexion	Conexión, Conj.
3		2	Ref. 2	Union	Union	Unión
4	835024M1	2		O-Ring	Joint torique	Junta de tipo O
5	6101540M91		1	Tube Assy	Tuyauterie	Conjunto de tubería
6	339123X1	M8 x 20	1	Bolt	Boulon	Perno
7	385361X1	M8	1	Washer	Rondelle	Arandela
8	835013M91		1	Connector Assy	Ensemble connexion	Conexión, Conj.
9		8	Ref. 8	Union	Union	Unión
10	835024M1	8		O-Ring	Joint torique	Junta de tipo O
11	6102309M91	Brown	1	Hose Assy	Ensemble de flexible	Flexible, Conj.
12	6107024M91	White	1	Hose Assy	Ensemble de flexible	Flexible, Conj.
13	6101771M91		2	Tube Assy	Tuyauterie	Conjunto de tubería
14	6108762M91	Brown	1	Hose Assy	Ensemble de flexible	Flexible, Conj.
15	6108763M91	White	1	Hose Assy	Ensemble de flexible	Flexible, Conj.
16	6102128M1		1	Pad	Plaque antidérapante	Cinta antideslizante
17	6102122M1		1	Bracket, Clamp	Bride de fixation	Brida de fijación
18	6102130M1		1	Plate	Plaque	Placa
19	390972X1	M8	2	Washer	Rondelle	Arandela
20	3516075M1	M8 x 65	2	Stud	Goujon	Espárrago
21	394367X1	M8	2	Nut, Lock	Écrou de blocage	Tuerca de retención
22	6102126M1		2	Bracket, Clamp	Bride de fixation	Brida de fijación
23	6102145M1		2	Pad	Plaque antidérapante	Cinta antideslizante
24	6102124M1		2	Plate	Plaque	Placa
25	390972X1	M8	4	Washer	Rondelle	Arandela
26	6108049M1		4	Stud	Goujon	Espárrago
27	394367X1	M8	4	Nut, Lock	Écrou de blocage	Tuerca de retención



860 880 970 980
 TX860B

817 825 845 855 921 931

76032C01.1

6199042M3

1

Jan-06

Digger Hydraulics
Circuit Hydraulique Défonceuse
Circuito hidráulico equipo retro

Sideshift
Montage de Pelle Latéral
Excavadora de montaje horizontal

Bucket Cylinder
Vérin de Godet
Gato de cuchara

High Spec.
 High Spec.
 High Spec.

C-76032-02.1-A

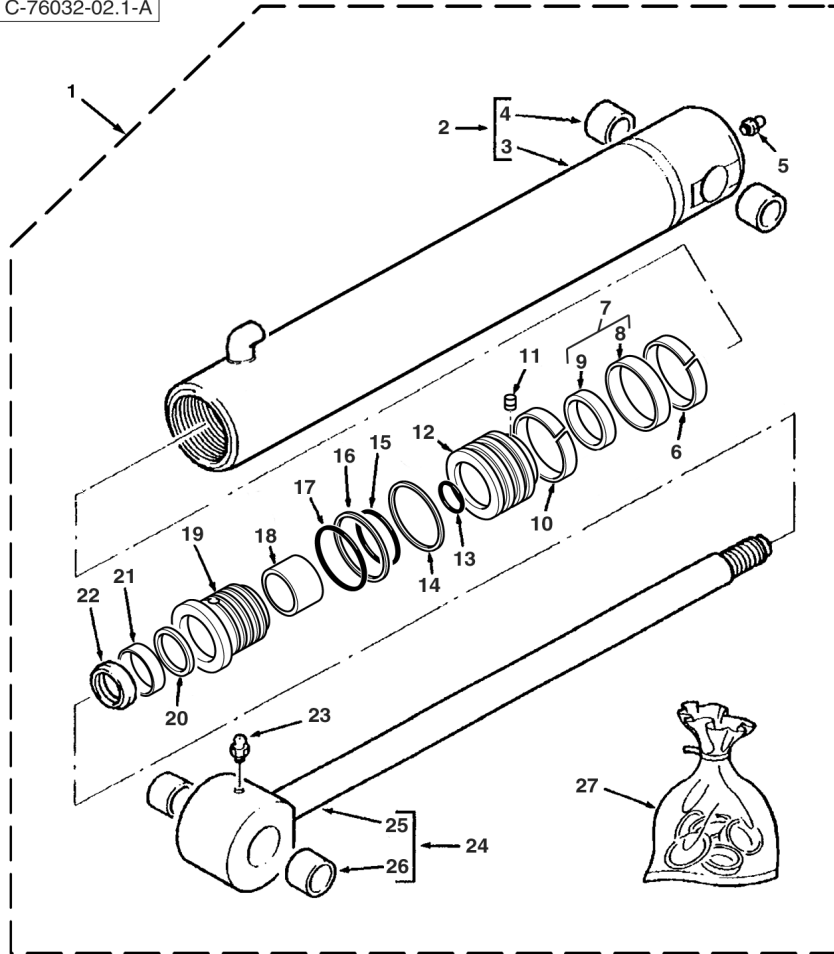

1	5000126M91		76032C01.1	1	Cylinder Assy	Ensemble de vérin	Gato, Conj.
2	5004008M91	1		1	Cylinder	Cylindre	Cilindro
3		3	Ref. 2	1	Tube, Cylinder	Cylindre de vérin	Cilindro de gato
4		3 (C)		1	Bushing	Bague	Anillo
5	339608X1	1		1	Fitting, Grease	Graisser	Engrasador
6	3485892M1	1 (A)		1	Ring, Sealing	Bague d'étanchéité	Anillo, Estanqueidad
7	3485245M91	1 (A)		1	Seal Assy	Ensemble de joint	Junta, Conj.
8		7	Ref. 7	1	Seal	Joint	Junta
9		7	Ref. 7	1	Ring	Anneau	Aro
10	3485892M1	1 (A)		1	Ring, Sealing	Bague d'étanchéité	Anillo, Estanqueidad
11	3402928M1	1		1	Screw	Vis	Tornillo
12	3623372M1	1		1	Piston	Piston	Pistón
13	359186X1	1 (A)		1	O-Ring	Joint torique	Junta de tipo O
14	3623061M1	1		1	Ring, Piston	Segment de piston	Segmento de pistón
15	359193X1	1 (A)		1	O-Ring	Joint torique	Junta de tipo O
16	1606735M1	1 (A)		1	Ring, Backup	Contre-joint	ContraJunta
17	3487207M1	1 (A)		1	O-Ring	Joint torique	Junta de tipo O
18	3484615M1	1 (A)		1	Ring	Anneau	Aro
19	3623371M1	1		1	Bearing	Coussinet	Cojinete
20	3484055M1	1 (A)		1	Ring	Anneau	Aro
21	3485185M1	1 (A)		1	Seal	Joint	Junta
22	3487015M1	1 (A)		1	Ring	Anneau	Aro
23	339608X1	1		1	Fitting, Grease	Graisser	Engrasador
24	5004012M91	1		1	Rod, Piston	Tige de vérin	Vástago cilindro
25		24	Ref. 24	1	Rod, Piston	Tige de vérin	Vástago cilindro
26		24 (C)		1	Bushing	Bague	Anillo
27	3623373M91		(B)	1	Kit, Seal	Pochette de joints	Juego de juntas

A Contains items marked (A)
 Comprend les pièces marquées (A)
 Incluye las piezas marcadas (A)

C Part number to be advised
 Référence pièce à demander
 Indicar número de pieza

B Included in kit marked (B)
 Inclus dans jeu marqué (B)
 Incluido en juego marcado (B)



860 880 970 980
 TX860B

817 825 845 855 921 931

76032C02.1

6199042M3

1

Jan-06

Digger Hydraulics
Circuit Hydraulique Défonceuse
Circuito hidráulico equipo retro

Sideshift
Montage de Pelle Latéral
Excavadora de montaje horizontal

Standard Dipper
Balancier Standard
Balancín estándar

High Spec.
 High Spec.
 High Spec.

C-76032-03.1-A

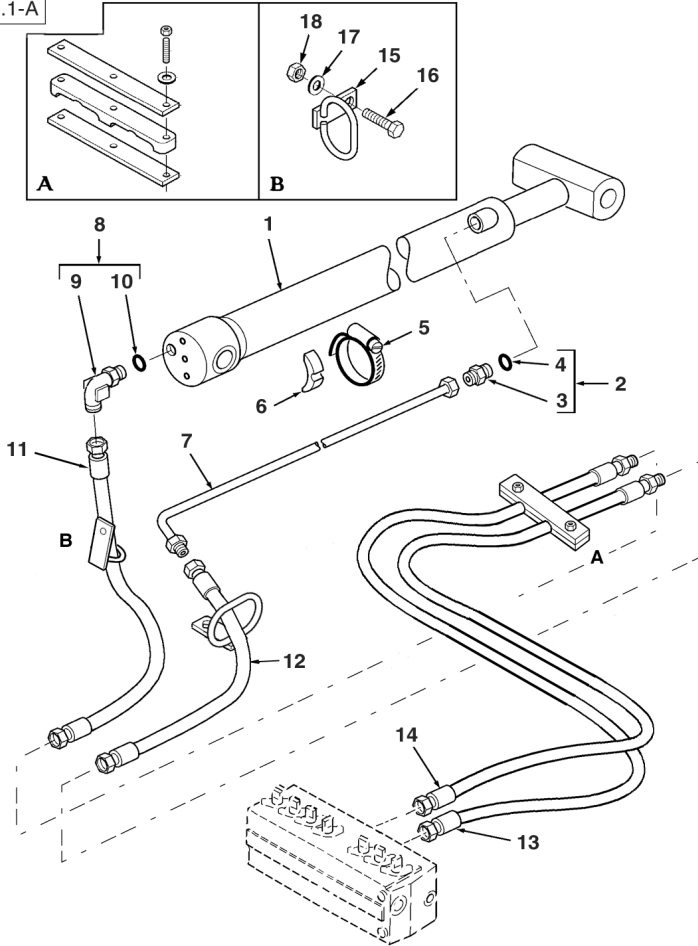

1	5000124M91	76032C04.1	1	Cylinder Assy	Ensemble de vérin	Gato, Conj.
2	835013M91		1	Connector Assy	Ensemble connexion	Conexión, Conj.
3		2	1	Union	Union	Unión
4	835024M1	2	1	O-Ring	Joint torique	Junta de tipo O
5	3517733M1		1	Clamp	Collier de serrage	Argolla de cierre
6	L79937		1	Spacer	Entretoise	Travesa
7	6100976M92	(A)	1	Tube Assy	Tuyauterie	Conjunto de tubería
8	6101624M91	(A)	1	Elbow, 90°	Coude à 90°	Codo, 90°
9		8	1	Elbow	Coude	Codo
10	835024M1	8	1	O-Ring	Joint torique	Junta de tipo O
11	6101738M91	Yellow	1	Hose Assy	Ensemble de flexible	Flexible, Conj.
12	6101737M91	Red	1	Hose Assy	Ensemble de flexible	Flexible, Conj.
13	6108767M91	Yellow	1	Hose Assy	Ensemble de flexible	Flexible, Conj.
14	6108766M91	Red	1	Hose Assy	Ensemble de flexible	Flexible, Conj.
15	6101491M92		2	Support Assy	Ensemble de support	Apoyadero, Conj.
16	339761X1	M8 x 25	2	Screw	Vis	Tornillo
17	390972X1	M8	2	Washer	Rondelle	Arandela
18	394367X1	M8	2	Nut, Lock	Écrou de blocage	Tuerca de retención

A Without Hose Burst
 Sans éclatement de tuyau
 Sin rotura de tubo flexible



860 880 970 980
 TX860B

817 825 845 855 921 931

76032C03.1

6199042M3

1

Jan-06

Digger Hydraulics
Circuit Hydraulique Défonceuse
Circuito hidráulico equipo retro

Sideshift
Montage de Pelle Latéral
Excavadora de montaje horizontal

Dipper Cylinder
Vérin de Balancier
Gato de balancín

High Spec.
 High Spec.
 High Spec.

C-76032-04.1-A

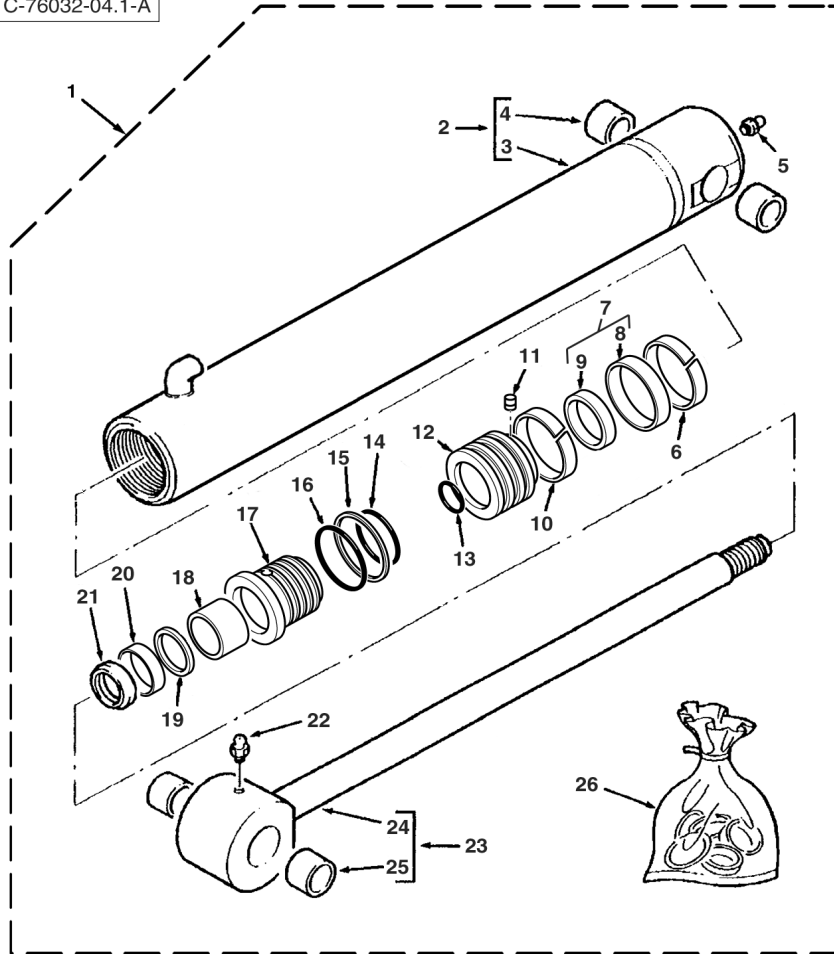

1	5000124M91	76032C03.1	1	Cylinder Assy	Ensemble de vérin	Gato, Conj.
2	5003982M91		1	Cylinder	Cylindre	Cilindro
3		Ref. 2	1	Tube, Cylinder	Cylindre de vérin	Cilindro de gato
4	3484843M1		2	Bush	Bague	Casquillo
5	339608X1		1	Fitting, Grease	Graisser	Engrasador
6	3485891M1	(A)	1	Ring	Anneau	Aro
7	3485247M91	(A)	1	Seal Assy	Ensemble de joint	Junta, Conj.
8		Ref. 7	1	Seal	Joint	Junta
9		Ref. 7	1	Ring	Anneau	Aro
10	3485891M1	(A)	1	Ring	Anneau	Aro
11	3402928M1		1	Screw	Vis	Tornillo
12	5003989M1		1	Piston	Piston	Pistón
13	3007182X1	(A)	1	O-Ring	Joint torique	Junta de tipo O
14	359196X1	(A)	1	O-Ring	Joint torique	Junta de tipo O
15	378545X1	(A)	1	Ring	Anneau	Aro
16	3487908M1	(A)	1	O-Ring	Joint torique	Junta de tipo O
17	5003988M1		1	Bearing	Coussinet	Cojinete
18	3623193M1	(A)	1	Ring	Anneau	Aro
19	3443388M1	(A)	1	Ring	Anneau	Aro
20	3443472M1	(A)	1	Seal	Joint	Junta
21	3403385M1	(A)	1	Ring, Wiper	Joint de racler	Junta raspador
22	339608X1		1	Fitting, Grease	Graisser	Engrasador
23	5003985M91		1	Rod, Piston	Tige de vérin	Vástago cilindro
24		Ref. 23	1	Rod, Piston	Tige de vérin	Vástago cilindro
25	3484843M1		23	Bush	Bague	Casquillo
26	5004401M91	(B)	1	Kit, Seal	Pochette de joints	Juego de juntas

A Included in kit marked (B)
 Inclus dans jeu marqué (B)
 Incluido en juego marcado (B)

B Contains items marked (A)
 Comprend les pièces marquées (A)
 Incluye las piezas marcadas (A)



860 880 970 980
 TX860B

817 825 845 855 921 931

76032C04.1

6199042M3

1

Jan-06

Digger Hydraulics
Circuit Hydraulique Défonceuse
Circuito hidráulico equipo retro

Sideshift
Montage de Pelle Latéral
Excavadora de montaje horizontal

Boom
 Flèche
 Pluma

High Spec.
 High Spec.
 High Spec.

C-76032-05.1-A

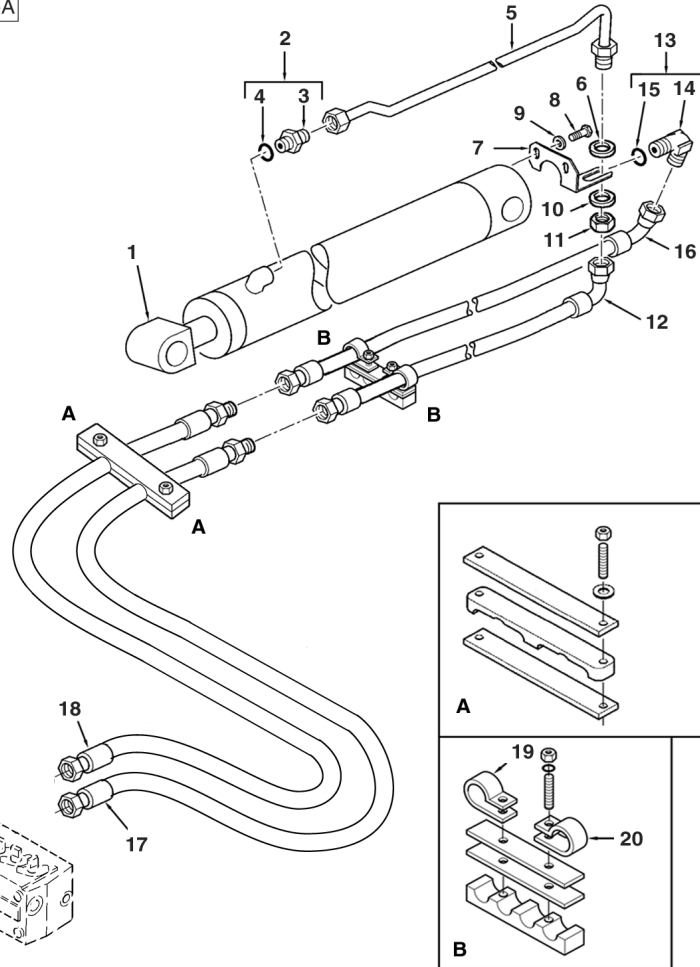

1	5000122M91	76032C06.1 1 4.5m Boom	1	Cylinder Assy	Ensemble de vérin	Gato, Conj.
2	835013M91		1	Connector Assy	Ensemble connexion	Conexión, Conj.
3		Ref. 2	1	Union	Union	Unión
4	835024M1		1	O-Ring	Joint torique	Junta de tipo O
5	6100855M91	(A)	1	Tube Assy	Tuyauterie	Conjunto de tubería
6	353763X1	(A)	1	Washer	Rondelle	Arandela
7	6100883M1	(A)	1	Bracket	Patte de fixation	Pata de fijación
8	339228X1	M8 x 12	2	Screw	Vis	Tornillo
9	339374X1	M8	2	Washer, Lock	Rondelle de blocage	Arandela de freno
10	353763X1	(A)	1	Washer	Rondelle	Arandela
11	355574X1	(A)	1	Nut	Écrou	Tuerca
12	6101735M92	(A)Orange	1	Hose Assy	Ensemble de flexible	Flexible, Conj.
13	835007M91	(A)	1	Elbow, 90°	Coude à 90°	Codo, 90°
14		Ref. 13	1	Elbow	Coude	Codo
15	835024M1		1	O-Ring	Joint torique	Junta de tipo O
16	6101736M92	Blue	1	Hose Assy	Ensemble de flexible	Flexible, Conj.
17	6108761M91	Orange	1	Hose Assy	Ensemble de flexible	Flexible, Conj.
18	6108760M91	Blue	1	Hose Assy	Ensemble de flexible	Flexible, Conj.
19	515-23270		1	Clip	Clip	Clip
20	515-23206		1	Clip	Clip	Clip

A Without Hose Burst
 Sans éclatement de tuyau
 Sin rotura de tubo flexible



860 880 970 980
 TX860B

817 825 845 855 921 931

76032C05.1

6199042M3

1

Jan-06

Digger Hydraulics
Circuit Hydraulique Défonceuse
Circuito hidráulico equipo retro

Sideshift
Montage de Pelle Latéral
Excavadora de montaje horizontal

Boom Cylinder
Vérin de Flèche
Gato de pluma

High Spec.
 High Spec.
 High Spec.

C-76032-06.1-A

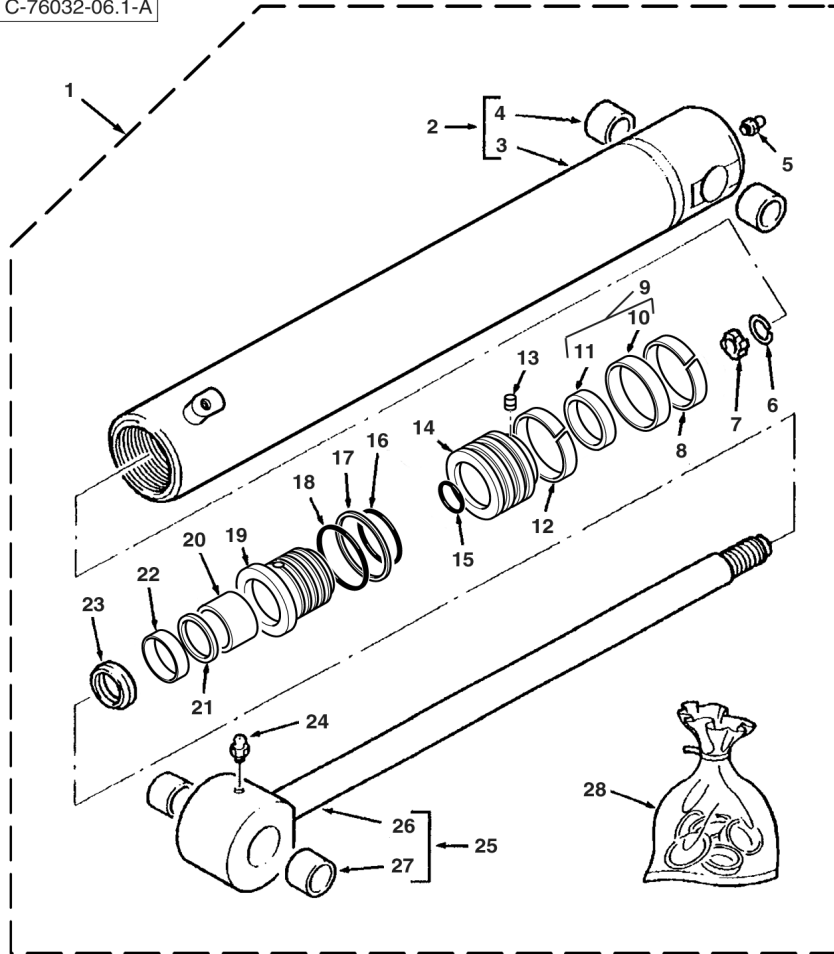

1	5000122M91	76032C05.1 1 4.5m Boom	1	Cylinder Assy	Ensemble de vérin	Gato, Conj.
2	5003912M91	1	1	Cylinder	Cylindre	Cilindro
3		2	1	Tube, Cylinder	Cylindre de vérin	Cilindro de gato
4		2 (C)	2	Bushing	Bague	Anillo
5	339608X1	1	1	Fitting, Grease	Graisser	Engrasador
6	1609899M1	1	1	Ring, Snap	Anneau d'arrêt	Anillo de resorte
7	1609328M1	1	1	Ring	Anneau	Aro
8	3403852M1	1 (A)	2	Ring	Anneau	Aro
9	3485213M91	1 (A)	1	Seal Assy	Ensemble de joint	Junta, Conj.
10		9	1	Seal	Joint	Junta
11		9	1	Seal	Joint	Junta
13	3402928M1	1	1	Screw	Vis	Tornillo
14	3484189M1	1	1	Piston	Piston	Pistón
15	3007182X1	1 (A)	1	O-Ring	Joint torique	Junta de tipo O
16	359203X1	1 (A)	1	O-Ring	Joint torique	Junta de tipo O
17	367120X1	1 (A)	1	Ring	Anneau	Aro
18	3487909M1	1 (A)	1	O-Ring	Joint torique	Junta de tipo O
19	3623202M1	1	1	Bearing	Coussinet	Cojinete
20	3623193M1	1 (A)	1	Ring	Anneau	Aro
21	3443388M1	1 (A)	1	Ring	Anneau	Aro
22	3443472M1	1 (A)	1	Seal	Joint	Junta
23	3403385M1	1 (A)	1	Ring, Wiper	Joint de racleur	Junta raspador
24	339608X1	1	1	Fitting, Grease	Graisser	Engrasador
25	3441629M91	1	1	Rod, Piston	Tige de vérin	Vástago cilindro
26		25	1	Rod, Piston	Tige de vérin	Vástago cilindro
27	3484843M1	25	1	Bush	Bague	Casquillo
28	3623589M91	(B)	1	Kit, Seal	Pochette de joints	Juego de juntas

A Included in kit marked (B)
 Inclus dans jeu marqué (B)
 Incluido en juego marcado (B)
 C Part number to be advised
 Référence pièce à demander
 Indicar número de pieza

B Contains items marked (A)
 Comprend les pièces marquées (A)
 Incluye las piezas marcadas (A)



860 880 970 980
 TX860B

817 825 845 855 921 931

76032C06.1

6199042M3

1

Jan-06

Digger Hydraulics
Circuit Hydraulique Défonceuse
Circuito hidráulico equipo retro

Sideshift
Montage de Pelle Latéral
Excavadora de montaje horizontal

Swing Components
Organes de Rotation
Componentes de rotación

Std. Spec.
 Std. Spec.
 Std. Spec.

C-76032-07.1-A

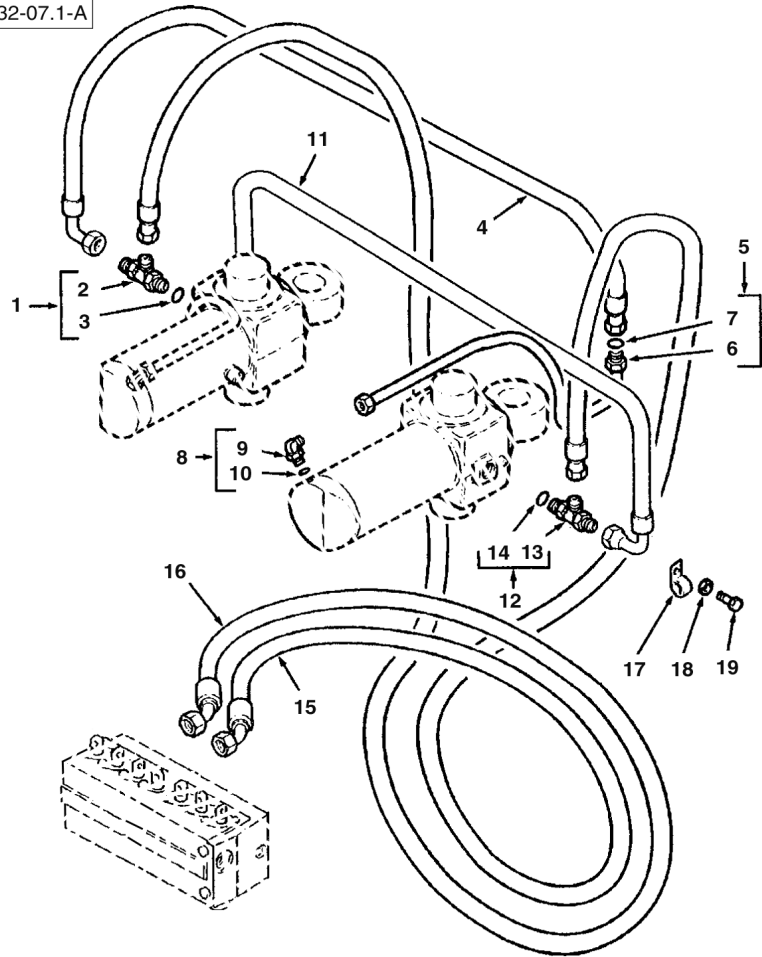

1	358728X91		1	Tee	Raccord en T	Te	
2		1	▶ Ref. 1	1	Tee	Raccord en T	Te
3	831497M1	1		1	O-Ring	Joint torique	Junta de tipo O
4	6100716M91	840 mm		1	Hose Assy	Ensemble de flexible	Flexible, Conj.
5	6100587M91	◀		1	Tube Assy	Tuyauterie	Conjunto de tubería
5	6100589M91	▶		1	Tube Assy	Tuyauterie	Conjunto de tubería
6		5	▶ Ref. 5	1	Tube	Tube	Tubo
7	394923X1	5		1	O-Ring	Joint torique	Junta de tipo O
8	357197X91			2	Elbow, 90°	Coude à 90°	Codo, 90°
9		8	▶ Ref. 8	1	Elbow	Coude	Codo
10	831452M1	8		1	O-Ring	Joint torique	Junta de tipo O
11	6100716M91	840 mm		1	Hose Assy	Ensemble de flexible	Flexible, Conj.
12	358728X91			1	Tee	Raccord en T	Te
13		12	▶ Ref. 12	1	Tee	Raccord en T	Te
14	831497M1	12		1	O-Ring	Joint torique	Junta de tipo O
15	6107456M91	◀ 1745 mm		1	Hose Assy	Ensemble de flexible	Flexible, Conj.
16	6107455M91	▶ 1745 mm		1	Hose Assy	Ensemble de flexible	Flexible, Conj.
17	3517114M2			2	Clip, Mounting	Collier de fixation	Argolla de fijación
18	385361X1	M8		2	Washer	Rondelle	Arandela
19	339228X1	M8 x 12		2	Screw	Vis	Tornillo



860 880 970 980
 TX860B

817 825 845 855 921 931

76032C07.1

6199042M3

1

Jan-06

Digger Hydraulics
 Circuit Hydraulique Défonceuse
 Circuito hidráulico equipo retro

Sideshift
 Montage de Pelle Latéral
 Excavadora de montaje horizontal

Clamp
 Collier
 Abrazadera

High Spec.
 High Spec.
 High Spec.

C-76032-08.1-A

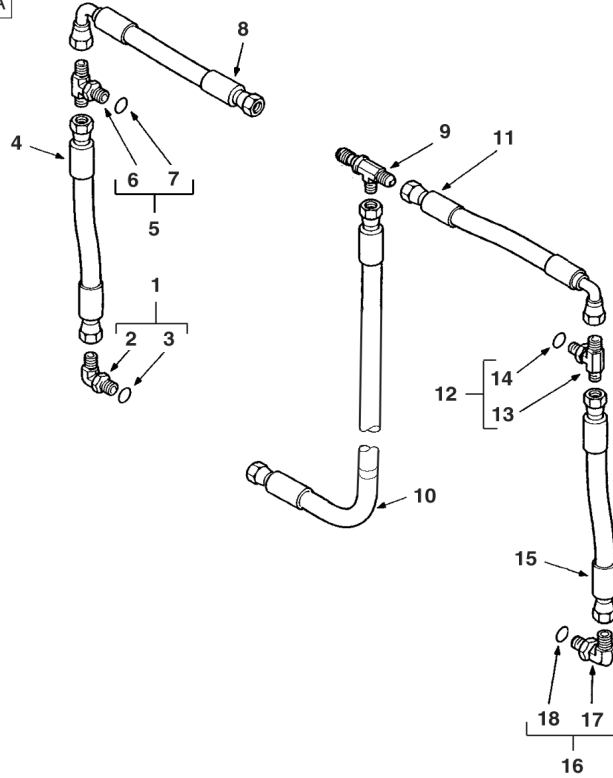

1	358761X91			1	Elbow, 90°	Coude à 90°	Codo, 90°
2		1	➡ Ref. 1	1	Elbow	Coude	Codo
3	831496M1	1		1	O-Ring	Joint torique	Junta de tipo O
4	3521882M94			1	Hose Assy	Ensemble de flexible	Flexible, Conj.
5	358827X91			1	Tee	Raccord en T	Te
6		5	➡ Ref. 5	1	Tee	Raccord en T	Te
7	831496M1	5		1	O-Ring	Joint torique	Junta de tipo O
8	3521878M93			1	Hose Assy	Ensemble de flexible	Flexible, Conj.
9	356558X1			1	Tee	Raccord en T	Te
10	6110207M91	Clamp		1	Hose Assy	Ensemble de flexible	Flexible, Conj.
11	3521878M93			1	Hose Assy	Ensemble de flexible	Flexible, Conj.
12	358827X91			1	Tee	Raccord en T	Te
13		12	➡ Ref. 12	1	Tee	Raccord en T	Te
14	831496M1	12		1	O-Ring	Joint torique	Junta de tipo O
15	3521882M94			1	Hose Assy	Ensemble de flexible	Flexible, Conj.
16	358761X91			1	Elbow, 90°	Coude à 90°	Codo, 90°
17		16	➡ Ref. 16	1	Elbow	Coude	Codo
18	831496M1	16		1	O-Ring	Joint torique	Junta de tipo O



860 880 970 980
 TX860B

817 825 845 855 921 931

76032C08.1

6199042M3

1

Jan-06

Digger Hydraulics
Circuit Hydraulique Défonceuse
Circuito hidráulico equipo retro

Sideshift
Montage de Pelle Latéral
Excavadora de montaje horizontal

Attachment
Attache
Equipo

C-76032-09.1-A

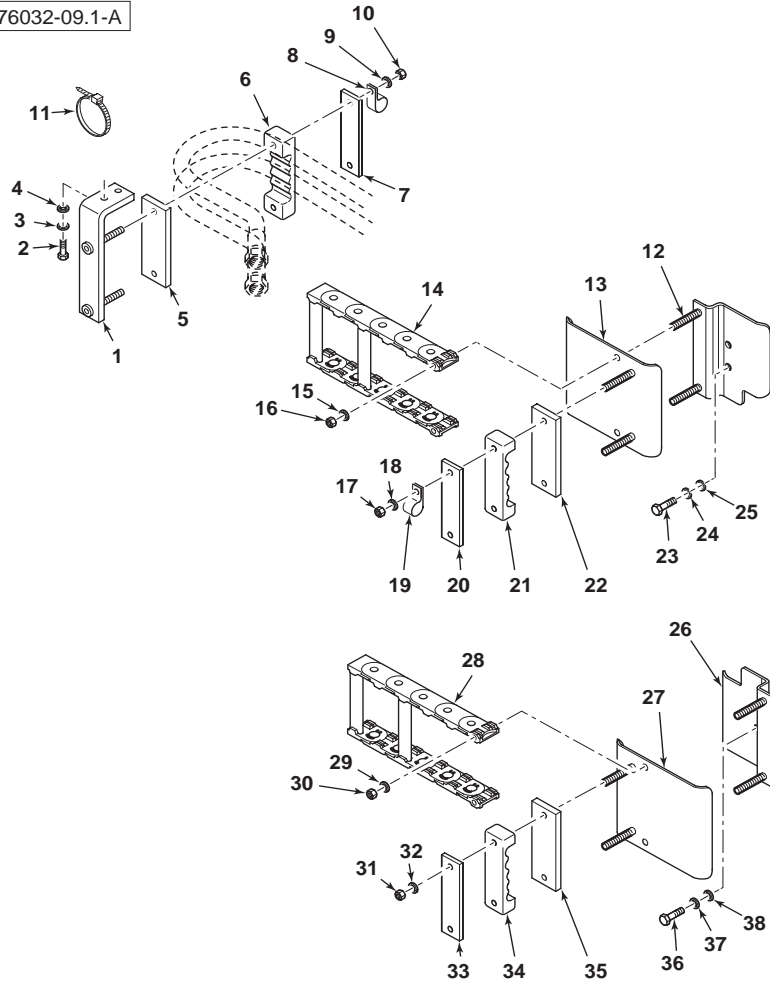

1	6107934M91		2	Bracket, Clamp	Bride de fixation	Brida de fijación
2	339761X1	M8 x 25	4	Screw	Vis	Tornillo
3	390972X1	M8	4	Washer	Rondelle	Arandela
4	339374X1	M8	4	Washer, Lock	Rondelle de blocage	Arandela de freno
5	6102197M1		2	Pad, Rubber	Plaque de caoutchouc	Placa, Caucho
6	6101216M1	◀	1	Clamp	Collier de serrage	Argolla de cierre
6	6101859M1	▶	1	Clamp	Collier de serrage	Argolla de cierre
7	6101215M1		2	Plate	Plaque	Placa
8	515-22159		1	Clip, Mounting	Collier de fixation	Argolla de fijación
9	390972X1	M8	4	Washer	Rondelle	Arandela
10	394367X1	M8	4	Nut, Lock	Écrou de blocage	Tuerca de retención
11	1862425M1		1	Tie, Cable	Attache câble	Enlace de Cable
12	6102307M91	▶	1	Bracket, Clamp	Bride de fixation	Brida de fijación
13	6101424M91		1	Plate Assy	Ensemble de plaque	Placa, Conj.
14	6102199M92		1	Chain	Chaîne	Cadena
15	390971X1	M6	2	Washer	Rondelle	Arandela
16	1441500X1	M6	2	Nut, Lock	Écrou de blocage	Tuerca de retención
17	394367X1	M8	2	Nut, Lock	Écrou de blocage	Tuerca de retención
18	390972X1	M8	2	Washer	Rondelle	Arandela
19	515-22159		1	Clip, Mounting	Collier de fixation	Argolla de fijación
20	6101215M1		1	Plate	Plaque	Placa
21	6101859M1		1	Clamp	Collier de serrage	Argolla de cierre
22	6102197M1		1	Pad, Rubber	Plaque de caoutchouc	Placa, Caucho
23	3009492X1	M10 x 25	2	Screw	Vis	Tornillo
24	339376X1	M10	2	Washer, Lock	Rondelle de blocage	Arandela de freno
25	390734X1	M10	2	Washer	Rondelle	Arandela
26	6102308M91	◀	1	Bracket, Clamp	Bride de fixation	Brida de fijación
27	6101424M91		1	Plate Assy	Ensemble de plaque	Placa, Conj.
28	6102199M92		1	Chain	Chaîne	Cadena
29	390971X1	M6	2	Washer	Rondelle	Arandela
30	1441500X1	M6	2	Nut, Lock	Écrou de blocage	Tuerca de retención
31	394367X1	M8	2	Nut, Lock	Écrou de blocage	Tuerca de retención
32	390972X1	M8	2	Washer	Rondelle	Arandela
33	6101215M1		1	Plate	Plaque	Placa
34	6101216M1	◀	1	Clamp	Collier de serrage	Argolla de cierre
35	6102197M1		1	Pad, Rubber	Plaque de caoutchouc	Placa, Caucho
36	3009492X1	M10 x 25	2	Screw	Vis	Tornillo
37	339376X1	M10	2	Washer, Lock	Rondelle de blocage	Arandela de freno
38	390734X1	M10	2	Washer	Rondelle	Arandela



860 880 970 980
 TX860B

817 825 845 855 921 931

76032C09.1

6199042M3

1

Jan-06

Digger Hydraulics
Circuit Hydraulique Défonceuse
Circuito hidráulico equipo retro

Sideshift
Montage de Pelle Latéral
Excavadora de montaje horizontal

Bucket
 Godet
 Cuchara

High Spec.
 High Spec.
 High Spec.

C-76033-01.1-A

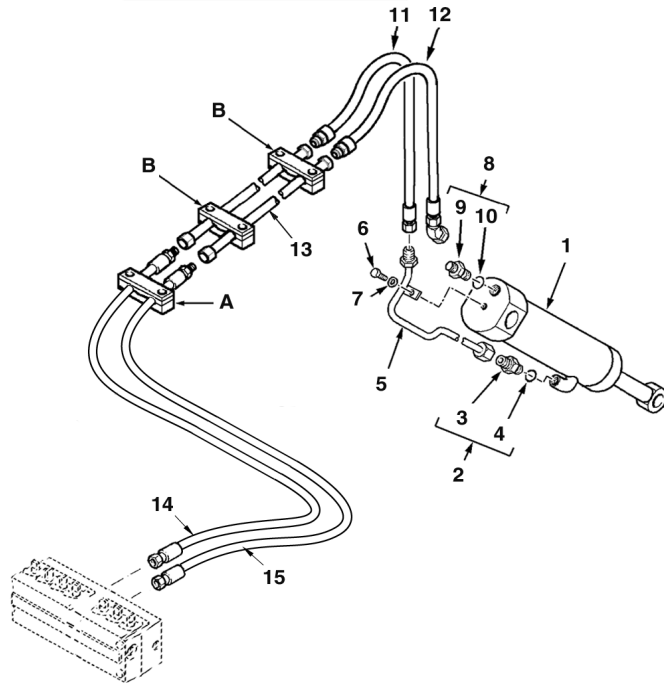
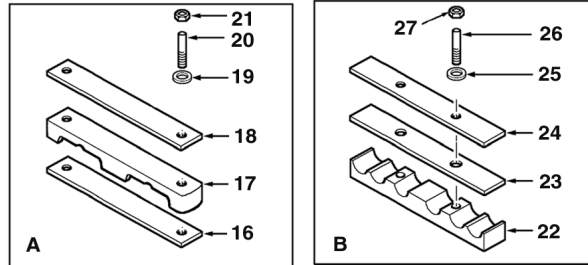

1	5000126M91	76033C02.1	1	Cylinder Assy	Ensemble de vérin	Gato, Conj.
2	835013M91		1	Connector Assy	Ensemble connexion	Conexión, Conj.
3		2	Ref. 2	Union	Union	Unión
4	835024M1	2		O-Ring	Joint torique	Junta de tipo O
5	6101540M91		1	Tube Assy	Tuyauterie	Conjunto de tubería
6	339123X1	M8 x 20	1	Bolt	Boulon	Perno
7	385361X1	M8	1	Washer	Rondelle	Arandela
8	835013M91		1	Connector Assy	Ensemble connexion	Conexión, Conj.
9		8	Ref. 8	Union	Union	Unión
10	835024M1	8		O-Ring	Joint torique	Junta de tipo O
11		(A)Brown	1	Hose Assy	Ensemble de flexible	Flexible, Conj.
12		(A)White	1	Hose Assy	Ensemble de flexible	Flexible, Conj.
13	6101771M91		2	Tube Assy	Tuyauterie	Conjunto de tubería
14	6108762M91	Brown	1	Hose Assy	Ensemble de flexible	Flexible, Conj.
15	6108763M91	White	1	Hose Assy	Ensemble de flexible	Flexible, Conj.
16	6102128M1		1	Pad	Plaque antidérapante	Cinta antideslizante
17	6102122M1		1	Bracket, Clamp	Bride de fixation	Brida de fijación
18	6102130M1		1	Plate	Plaque	Placa
19	390972X1	M8	2	Washer	Rondelle	Arandela
20	3516075M1	M8 x 65	2	Stud	Goujon	Espárrago
21	394367X1	M8	2	Nut, Lock	Écrou de blocage	Tuerca de retención
22	6102126M1		2	Bracket, Clamp	Bride de fixation	Brida de fijación
23	6102145M1		2	Pad	Plaque antidérapante	Cinta antideslizante
24	6102124M1		2	Plate	Plaque	Placa
25	390972X1	M8	4	Washer	Rondelle	Arandela
26	6108049M1		4	Stud	Goujon	Espárrago
27	394367X1	M8	4	Nut, Lock	Écrou de blocage	Tuerca de retención

A See extendahoe hydraulics section
 Voir la section circuit hydraulique extendahoe
 Ver la sección de la circuito hidráulico extendahoe



860 880 970 980
 TX860B

817 825 845 855 921 931

76033C01.1

6199042M3

1

Jan-06

Digger Hydraulics
Circuit Hydraulique Défonceuse
Circuito hidráulico equipo retro

Sideshift
Montage de Pelle Latéral
Excavadora de montaje horizontal

Bucket Cylinder
Vérin de Godet
Gato de cuchara

High Spec.
 High Spec.
 High Spec.

C-76033-02.1-A

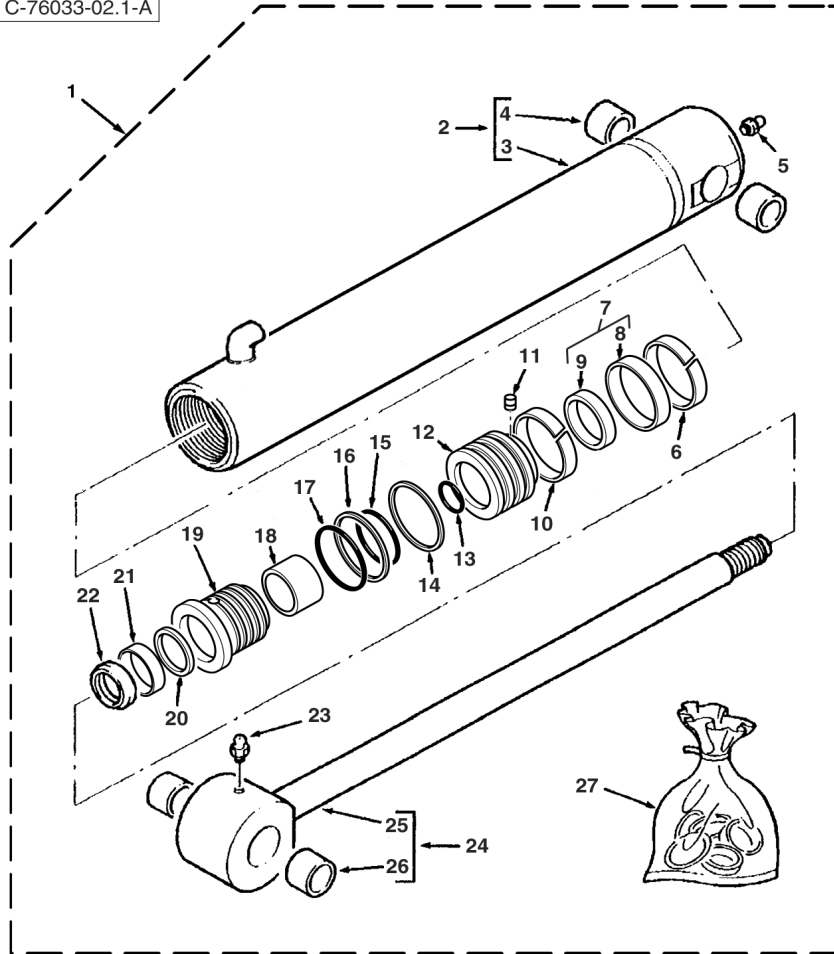

1	5000126M91		76033C01.1	1	Cylinder Assy	Ensemble de vérin	Gato, Conj.
2	5004008M91	1		1	Cylinder	Cylindre	Cilindro
3		3	Ref. 2	1	Tube, Cylinder	Cylindre de vérin	Cilindro de gato
4		3 (C)		1	Bushing	Bague	Anillo
5	339608X1	1		1	Fitting, Grease	Graisneur	Engrasador
6	3485892M1	1 (A)		1	Ring, Sealing	Bague d'étanchéité	Anillo, Estanqueidad
7	3485245M91	1 (A)		1	Seal Assy	Ensemble de joint	Junta, Conj.
8		7	Ref. 7	1	Seal	Joint	Junta
9		7	Ref. 7	1	Ring	Anneau	Aro
10	3485892M1	1 (A)		1	Ring, Sealing	Bague d'étanchéité	Anillo, Estanqueidad
11	3402928M1	1		1	Screw	Vis	Tornillo
12	3623372M1	1		1	Piston	Piston	Pistón
13	359186X1	1 (A)		1	O-Ring	Joint torique	Junta de tipo O
14	3623061M1	1		1	Ring, Piston	Segment de piston	Segmento de pistón
15	359193X1	1 (A)		1	O-Ring	Joint torique	Junta de tipo O
16	1606735M1	1 (A)		1	Ring, Backup	Contre-joint	ContraJunta
17	3487207M1	1 (A)		1	O-Ring	Joint torique	Junta de tipo O
18	3484615M1	1 (A)		1	Ring	Anneau	Aro
19	3623371M1	1		1	Bearing	Coussinet	Cojinete
20	3484055M1	1 (A)		1	Ring	Anneau	Aro
21	3485185M1	1 (A)		1	Seal	Joint	Junta
22	3487015M1	1 (A)		1	Ring	Anneau	Aro
23	339608X1	1		1	Fitting, Grease	Graisneur	Engrasador
24	5004012M91	1		1	Rod, Piston	Tige de vérin	Vástago cilindro
25		24	Ref. 24	1	Rod, Piston	Tige de vérin	Vástago cilindro
26		24 (C)		1	Bushing	Bague	Anillo
27	3623373M91		(B)	1	Kit, Seal	Pochette de joints	Juego de juntas

A Contains items marked (A)
 Comprend les pièces marquées (A)
 Incluye las piezas marcadas (A)

C Part number to be advised
 Référence pièce à demander
 Indicar número de pieza

B Included in kit marked (B)
 Inclus dans jeu marqué (B)
 Incluido en juego marcado (B)



860 880 970 980
 TX860B

817 825 845 855 921 931

76033C02.1

6199042M3

1

Jan-06

Digger Hydraulics
Circuit Hydraulique Défonceuse
Circuito hidráulico equipo retro

Sideshift
Montage de Pelle Latéral
Excavadora de montaje horizontal

Telescopic Dipper
Balancier Téléscopique
Balancín telescópico

High Spec.
 High Spec.
 High Spec.

C-76033-03.1-A

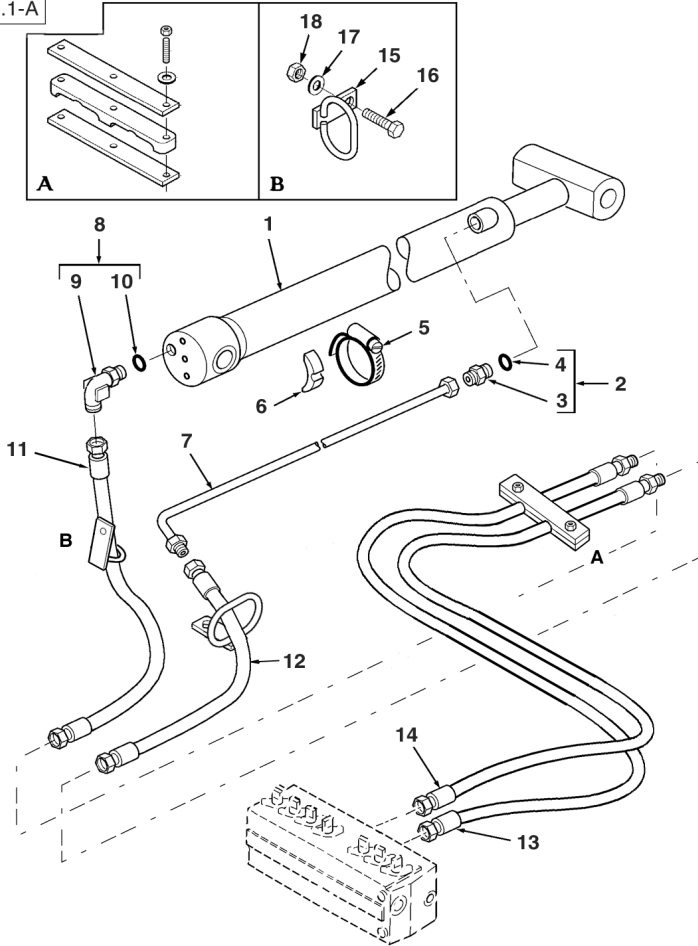

1	5000124M91	76033C04.1	1	Cylinder Assy	Ensemble de vérin	Gato, Conj.
2	835013M91		1	Connector Assy	Ensemble connexion	Conexión, Conj.
3		2	1	Union	Union	Unión
4	835024M1	2	1	O-Ring	Joint torique	Junta de tipo O
5	3517733M1		1	Clamp	Collier de serrage	Argolla de cierre
6	L79937		1	Spacer	Entretoise	Travesa
7	6100976M92	(A)	1	Tube Assy	Tuyauterie	Conjunto de tubería
8	6101624M91	(A)	1	Elbow, 90°	Coude à 90°	Codo, 90°
9		8	1	Elbow	Coude	Codo
10	835024M1	8	1	O-Ring	Joint torique	Junta de tipo O
11	6101738M91	Yellow	1	Hose Assy	Ensemble de flexible	Flexible, Conj.
12	6101737M91	Red	1	Hose Assy	Ensemble de flexible	Flexible, Conj.
13	6108767M91	Yellow	1	Hose Assy	Ensemble de flexible	Flexible, Conj.
14	6108766M91	Red	1	Hose Assy	Ensemble de flexible	Flexible, Conj.
15	6101491M92		2	Support Assy	Ensemble de support	Apoyadero, Conj.
16	339761X1	M8 x 25	2	Screw	Vis	Tornillo
17	390972X1	M8	2	Washer	Rondelle	Arandela
18	394367X1	M8	2	Nut, Lock	Écrou de blocage	Tuerca de retención

A Without Hose Burst
 Sans éclatement de tuyau
 Sin rotura de tubo flexible



860 880 970 980
 TX860B

817 825 845 855 921 931

76033C03.1

6199042M3

1

Jan-06

Digger Hydraulics
Circuit Hydraulique Défonceuse
Circuito hidráulico equipo retro

Sideshift
Montage de Pelle Latéral
Excavadora de montaje horizontal

Dipper Cylinder
Vérin de Balancier
Gato de balancín

High Spec.
 High Spec.
 High Spec.

C-76033-04.1-A

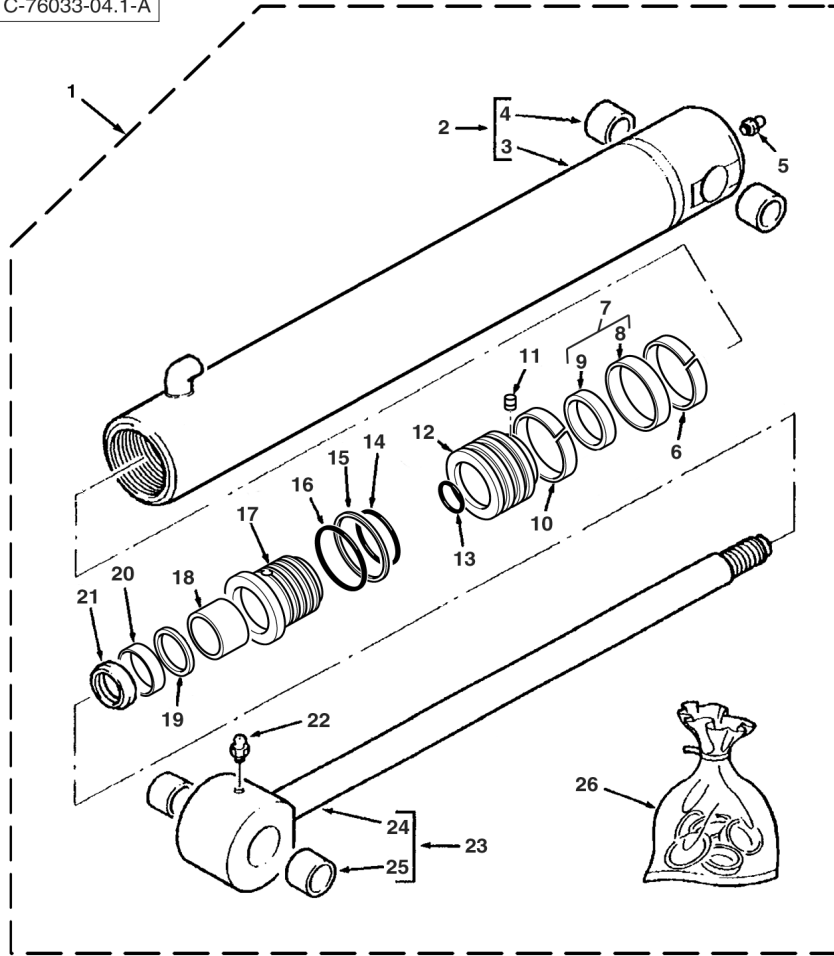

1	5000124M91	76033C03.1	1	Cylinder Assy	Ensemble de vérin	Gato, Conj.
2	5003982M91		1	Cylinder	Cylindre	Cilindro
3		Ref. 2	1	Tube, Cylinder	Cylindre de vérin	Cilindro de gato
4	3484843M1		2	Bush	Bague	Casquillo
5	339608X1		1	Fitting, Grease	Graisneur	Engrasador
6	3485891M1	(A)	1	Ring	Anneau	Aro
7	3485247M91	(A)	1	Seal Assy	Ensemble de joint	Junta, Conj.
8		Ref. 7	1	Seal	Joint	Junta
9		Ref. 7	1	Ring	Anneau	Aro
10	3485891M1	(A)	1	Ring	Anneau	Aro
11	3402928M1		1	Screw	Vis	Tornillo
12	5003989M1		1	Piston	Piston	Pistón
13	3007182X1	(A)	1	O-Ring	Joint torique	Junta de tipo O
14	359196X1	(A)	1	O-Ring	Joint torique	Junta de tipo O
15	378545X1	(A)	1	Ring	Anneau	Aro
16	3487908M1	(A)	1	O-Ring	Joint torique	Junta de tipo O
17	5003988M1		1	Bearing	Coussinet	Cojinete
18	3623193M1	(A)	1	Ring	Anneau	Aro
19	3443388M1	(A)	1	Ring	Anneau	Aro
20	3443472M1	(A)	1	Seal	Joint	Junta
21	3403385M1	(A)	1	Ring, Wiper	Joint de racler	Junta raspador
22	339608X1		1	Fitting, Grease	Graisneur	Engrasador
23	5003985M91		1	Rod, Piston	Tige de vérin	Vástago cilindro
24		Ref. 23	1	Rod, Piston	Tige de vérin	Vástago cilindro
25	3484843M1		23	Bush	Bague	Casquillo
26	5004401M91	(B)	1	Kit, Seal	Pochette de joints	Juego de juntas

A Included in kit marked (B)
 Inclus dans jeu marqué (B)
 Incluido en juego marcado (B)

B Contains items marked (A)
 Comprend les pièces marquées (A)
 Incluye las piezas marcadas (A)



860 880 970 980
 TX860B

817 825 845 855 921 931

76033C04.1

6199042M3

1

Jan-06

Digger Hydraulics
Circuit Hydraulique Défonceuse
Circuito hidráulico equipo retro

Sideshift
Montage de Pelle Latéral
Excavadora de montaje horizontal

Boom
 Flèche
 Pluma

High Spec.
 High Spec.
 High Spec.

C-76033-05.1-A

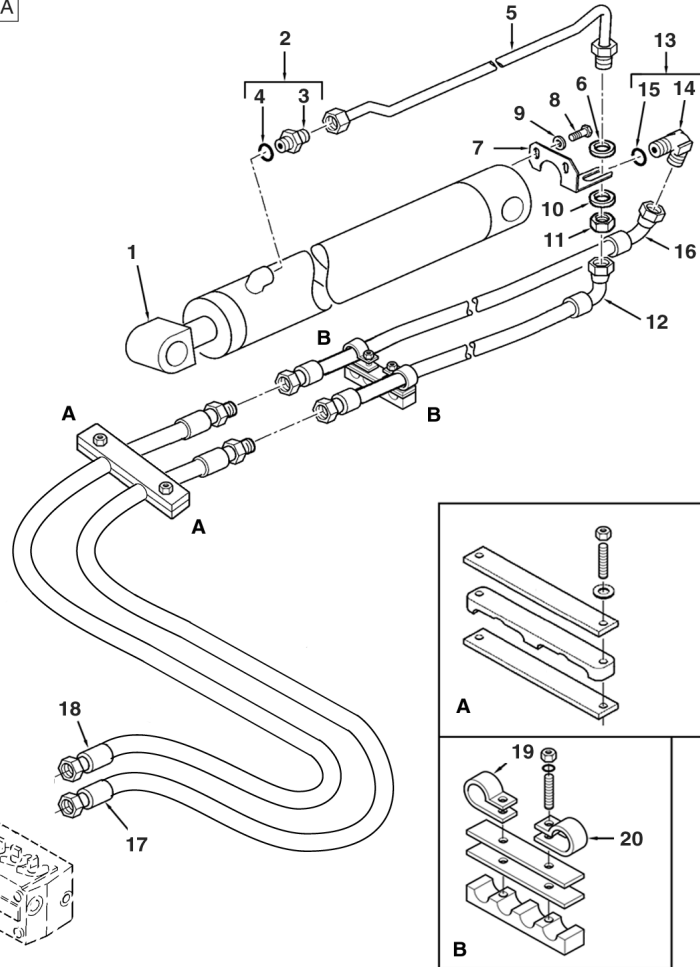

1	5000122M91	76033C06.1 1 4.5m Boom	1	Cylinder Assy	Ensemble de vérin	Gato, Conj.
2	835013M91		1	Connector Assy	Ensemble connexion	Conexión, Conj.
3		Ref. 2	1	Union	Union	Unión
4	835024M1		1	O-Ring	Joint torique	Junta de tipo O
5	6100855M91	(A)	1	Tube Assy	Tuyauterie	Conjunto de tubería
6	353763X1	(A)	1	Washer	Rondelle	Arandela
7	6100883M1	(A)	1	Bracket	Patte de fixation	Pata de fijación
8	339228X1	M8 x 12	2	Screw	Vis	Tornillo
9	339374X1	M8	2	Washer, Lock	Rondelle de blocage	Arandela de freno
10	353763X1	(A)	1	Washer	Rondelle	Arandela
11	355574X1	(A)	1	Nut	Écrou	Tuerca
12	6101735M92	(A)Orange	1	Hose Assy	Ensemble de flexible	Flexible, Conj.
13	835007M91	(A)	1	Elbow, 90°	Coude à 90°	Codo, 90°
14		Ref. 13	1	Elbow	Coude	Codo
15	835024M1		1	O-Ring	Joint torique	Junta de tipo O
16	6101736M92	Blue	1	Hose Assy	Ensemble de flexible	Flexible, Conj.
17	6108761M91	Orange	1	Hose Assy	Ensemble de flexible	Flexible, Conj.
18	6108760M91	Blue	1	Hose Assy	Ensemble de flexible	Flexible, Conj.
19	515-23270		1	Clip	Clip	Clip
20	515-23206		1	Clip	Clip	Clip

A Without Hose Burst
 Sans éclatement de tuyau
 Sin rotura de tubo flexible



860 880 970 980
 TX860B

817 825 845 855 921 931

76033C05.1

6199042M3

1

Jan-06

Digger Hydraulics
Circuit Hydraulique Défonceuse
Circuito hidráulico equipo retro

Sideshift
Montage de Pelle Latéral
Excavadora de montaje horizontal

Boom Cylinder
Vérin de Flèche
Gato de pluma

High Spec.
 High Spec.
 High Spec.

C-76033-06.1-A

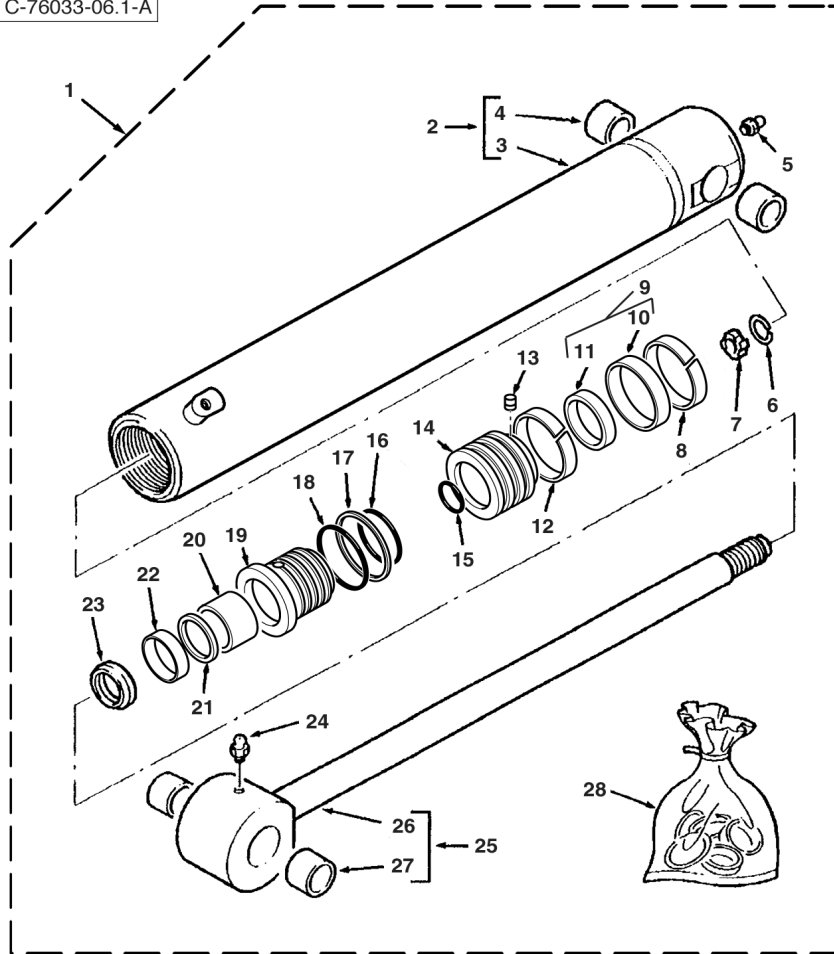

1	5000122M91	76033C05.1 1 4.5m Boom	1	Cylinder Assy	Ensemble de vérin	Gato, Conj.
2	5003912M91	1	1	Cylinder	Cylindre	Cilindro
3		2	1	Tube, Cylinder	Cylindre de vérin	Cilindro de gato
4		2 (C)	2	Bushing	Bague	Anillo
5	339608X1	1	1	Fitting, Grease	Graisseur	Engrasador
6	1609899M1	1	1	Ring, Snap	Anneau d'arrêt	Anillo de resorte
7	1609328M1	1	1	Ring	Anneau	Aro
8	3403852M1	1 (A)	2	Ring	Anneau	Aro
9	3485213M91	1 (A)	1	Seal Assy	Ensemble de joint	Junta, Conj.
10		9	1	Seal	Joint	Junta
11		9	1	Seal	Joint	Junta
13	3402928M1	1	1	Screw	Vis	Tornillo
14	3484189M1	1	1	Piston	Piston	Pistón
15	3007182X1	1 (A)	1	O-Ring	Joint torique	Junta de tipo O
16	359203X1	1 (A)	1	O-Ring	Joint torique	Junta de tipo O
17	367120X1	1 (A)	1	Ring	Anneau	Aro
18	3487909M1	1 (A)	1	O-Ring	Joint torique	Junta de tipo O
19	3623202M1	1	1	Bearing	Coussinet	Cojinete
20	3623193M1	1 (A)	1	Ring	Anneau	Aro
21	3443388M1	1 (A)	1	Ring	Anneau	Aro
22	3443472M1	1 (A)	1	Seal	Joint	Junta
23	3403385M1	1 (A)	1	Ring, Wiper	Joint de racleur	Junta raspador
24	339608X1	1	1	Fitting, Grease	Graisseur	Engrasador
25	3441629M91	1	1	Rod, Piston	Tige de vérin	Vástago cilindro
26		25	1	Rod, Piston	Tige de vérin	Vástago cilindro
27	3484843M1	25	1	Bush	Bague	Casquillo
28	3623589M91	(B)	1	Kit, Seal	Pochette de joints	Juego de juntas

A Included in kit marked (B)
 Inclus dans jeu marqué (B)
 Incluido en juego marcado (B)
 C Part number to be advised
 Référence pièce à demander
 Indicar número de pieza

B Contains items marked (A)
 Comprend les pièces marquées (A)
 Incluye las piezas marcadas (A)



860 880 970 980
 TX860B

817 825 845 855 921 931

76033C06.1

6199042M3

1

Jan-06

Digger Hydraulics
Circuit Hydraulique Défonceuse
Circuito hidráulico equipo retro

Sideshift
Montage de Pelle Latéral
Excavadora de montaje horizontal

Swing Components
Organes de Rotation
Componentes de rotación

High Spec.
 High Spec.
 High Spec.

C-76033-07.1-A

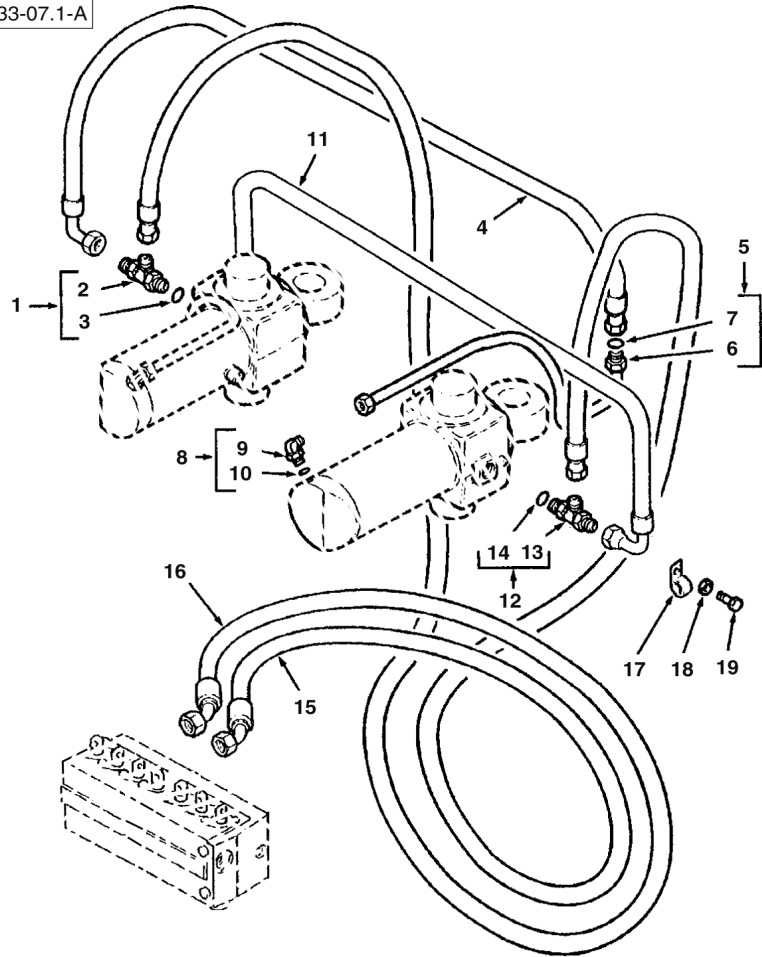

1	358728X91		1	Tee	Raccord en T	Te	
2		1	▶ Ref. 1	1	Tee	Raccord en T	Te
3	831497M1	1		1	O-Ring	Joint torique	Junta de tipo O
4	6100716M91	840 mm		1	Hose Assy	Ensemble de flexible	Flexible, Conj.
5	6100587M91	◀		1	Tube Assy	Tuyauterie	Conjunto de tubería
5	6100589M91	▶		1	Tube Assy	Tuyauterie	Conjunto de tubería
6		5	▶ Ref. 5	1	Tube	Tube	Tubo
7	394923X1	5		1	O-Ring	Joint torique	Junta de tipo O
8	357197X91			2	Elbow, 90°	Coude à 90°	Codo, 90°
9		8	▶ Ref. 8	1	Elbow	Coude	Codo
10	831452M1	8		1	O-Ring	Joint torique	Junta de tipo O
11	6100716M91	840 mm		1	Hose Assy	Ensemble de flexible	Flexible, Conj.
12	358728X91			1	Tee	Raccord en T	Te
13		12	▶ Ref. 12	1	Tee	Raccord en T	Te
14	831497M1	12		1	O-Ring	Joint torique	Junta de tipo O
15	6107456M91	◀ 1745 mm		1	Hose Assy	Ensemble de flexible	Flexible, Conj.
16	6107455M91	▶ 1745 mm		1	Hose Assy	Ensemble de flexible	Flexible, Conj.
17	3517114M2			2	Clip, Mounting	Collier de fixation	Argolla de fijación
18	385361X1	M8		2	Washer	Rondelle	Arandela
19	339228X1	M8 x 12		2	Screw	Vis	Tornillo



860 880 970 980
 TX860B

817 825 845 855 921 931

76033C07.1

6199042M3

1

Jan-06

Digger Hydraulics
 Circuit Hydraulique Défonceuse
 Circuito hidráulico equipo retro

Sideshift
 Montage de Pelle Latéral
 Excavadora de montaje horizontal

Clamp
 Collier
 Abrazadera

High Spec.
 High Spec.
 High Spec.

C-76033-08.1-A

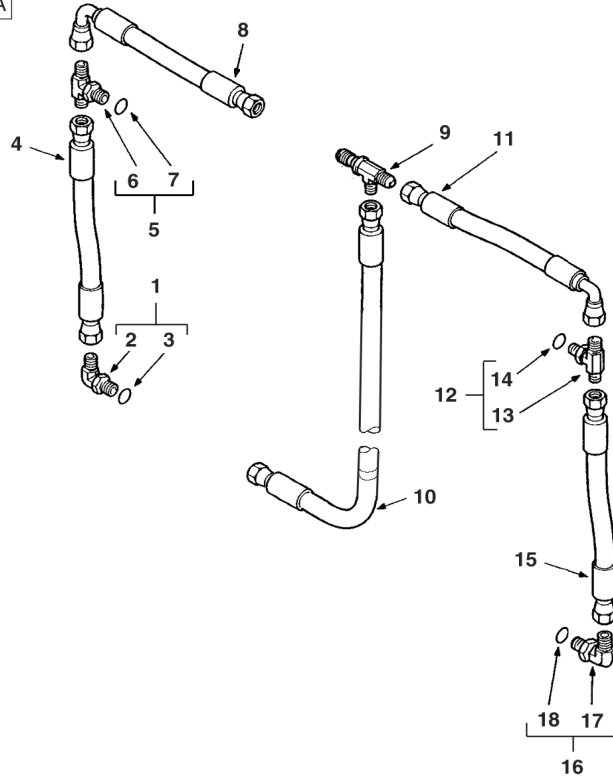

1	358761X91			1	Elbow, 90°	Coude à 90°	Codo, 90°
2		1	➡ Ref. 1	1	Elbow	Coude	Codo
3	831496M1	1		1	O-Ring	Joint torique	Junta de tipo O
4	3521882M94			1	Hose Assy	Ensemble de flexible	Flexible, Conj.
5	358827X91			1	Tee	Raccord en T	Te
6		5	➡ Ref. 5	1	Tee	Raccord en T	Te
7	831496M1	5		1	O-Ring	Joint torique	Junta de tipo O
8	3521878M93			1	Hose Assy	Ensemble de flexible	Flexible, Conj.
9	356558X1			1	Tee	Raccord en T	Te
10	6110207M91	Clamp		1	Hose Assy	Ensemble de flexible	Flexible, Conj.
11	3521878M93			1	Hose Assy	Ensemble de flexible	Flexible, Conj.
12	358827X91			1	Tee	Raccord en T	Te
13		12	➡ Ref. 12	1	Tee	Raccord en T	Te
14	831496M1	12		1	O-Ring	Joint torique	Junta de tipo O
15	3521882M94			1	Hose Assy	Ensemble de flexible	Flexible, Conj.
16	358761X91			1	Elbow, 90°	Coude à 90°	Codo, 90°
17		16	➡ Ref. 16	1	Elbow	Coude	Codo
18	831496M1	16		1	O-Ring	Joint torique	Junta de tipo O



860 880 970 980
 TX860B

817 825 845 855 921 931

76033C08.1

6199042M3

1

Jan-06

Digger Hydraulics
Circuit Hydraulique Défonceuse
Circuito hidráulico equipo retro

Sideshift
Montage de Pelle Latéral
Excavadora de montaje horizontal

Attachment
Attache
Equipo

C-76033-09.1-A

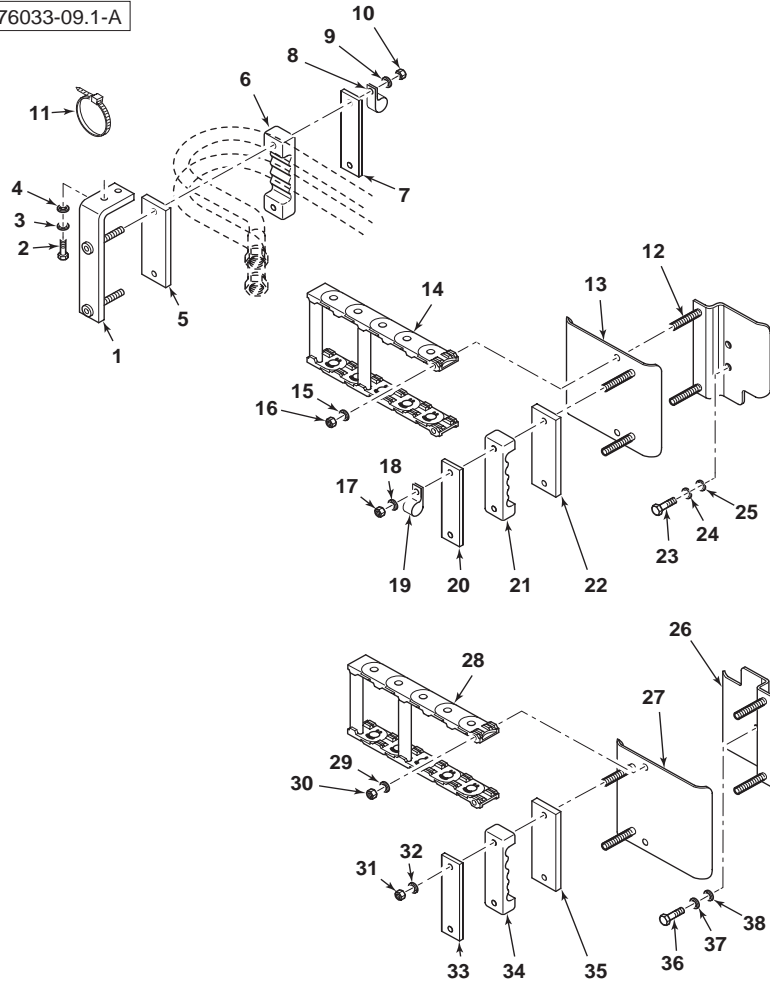

1	6107934M91		2	Bracket, Clamp	Bride de fixation	Brida de fijación
2	339761X1	M8 x 25	4	Screw	Vis	Tornillo
3	390972X1	M8	4	Washer	Rondelle	Arandela
4	339374X1	M8	4	Washer, Lock	Rondelle de blocage	Arandela de freno
5	6102197M1		2	Pad, Rubber	Plaque de caoutchouc	Placa, Caucho
6	6101216M1	◀	1	Clamp	Collier de serrage	Argolla de cierre
6	6101859M1	▶	1	Clamp	Collier de serrage	Argolla de cierre
7	6101215M1		2	Plate	Plaque	Placa
8	515-22159		1	Clip, Mounting	Collier de fixation	Argolla de fijación
9	390972X1	M8	4	Washer	Rondelle	Arandela
10	394367X1	M8	4	Nut, Lock	Écrou de blocage	Tuerca de retención
11	1862425M1		1	Tie, Cable	Attache câble	Enlace de Cable
12	6102307M91	▶	1	Bracket, Clamp	Bride de fixation	Brida de fijación
13	6101424M91		1	Plate Assy	Ensemble de plaque	Placa, Conj.
14	6102199M92		1	Chain	Chaîne	Cadena
15	390971X1	M6	2	Washer	Rondelle	Arandela
16	1441500X1	M6	2	Nut, Lock	Écrou de blocage	Tuerca de retención
17	394367X1	M8	2	Nut, Lock	Écrou de blocage	Tuerca de retención
18	390972X1	M8	2	Washer	Rondelle	Arandela
19	515-22159		1	Clip, Mounting	Collier de fixation	Argolla de fijación
20	6101215M1		1	Plate	Plaque	Placa
21	6101859M1		1	Clamp	Collier de serrage	Argolla de cierre
22	6102197M1		1	Pad, Rubber	Plaque de caoutchouc	Placa, Caucho
23	3009492X1	M10 x 25	2	Screw	Vis	Tornillo
24	339376X1	M10	2	Washer, Lock	Rondelle de blocage	Arandela de freno
25	390734X1	M10	2	Washer	Rondelle	Arandela
26	6102308M91	◀	1	Bracket, Clamp	Bride de fixation	Brida de fijación
27	6101424M91		1	Plate Assy	Ensemble de plaque	Placa, Conj.
28	6102199M92		1	Chain	Chaîne	Cadena
29	390971X1	M6	2	Washer	Rondelle	Arandela
30	1441500X1	M6	2	Nut, Lock	Écrou de blocage	Tuerca de retención
31	394367X1	M8	2	Nut, Lock	Écrou de blocage	Tuerca de retención
32	390972X1	M8	2	Washer	Rondelle	Arandela
33	6101215M1		1	Plate	Plaque	Placa
34	6101216M1	◀	1	Clamp	Collier de serrage	Argolla de cierre
35	6102197M1		1	Pad, Rubber	Plaque de caoutchouc	Placa, Caucho
36	3009492X1	M10 x 25	2	Screw	Vis	Tornillo
37	339376X1	M10	2	Washer, Lock	Rondelle de blocage	Arandela de freno
38	390734X1	M10	2	Washer	Rondelle	Arandela



860 880 970 980
 TX860B

817 825 845 855 921 931

76033C09.1

6199042M3

1

Jan-06

Digger Hydraulics
Circuit Hydraulique Défonceuse
Circuito hidráulico equipo retro

Sideshift
Montage de Pelle Latéral
Excavadora de montaje horizontal

Bucket
 Godet
 Cuchara

Std. Spec.
 Std. Spec.
 Std. Spec.

C-76034-01.1-A

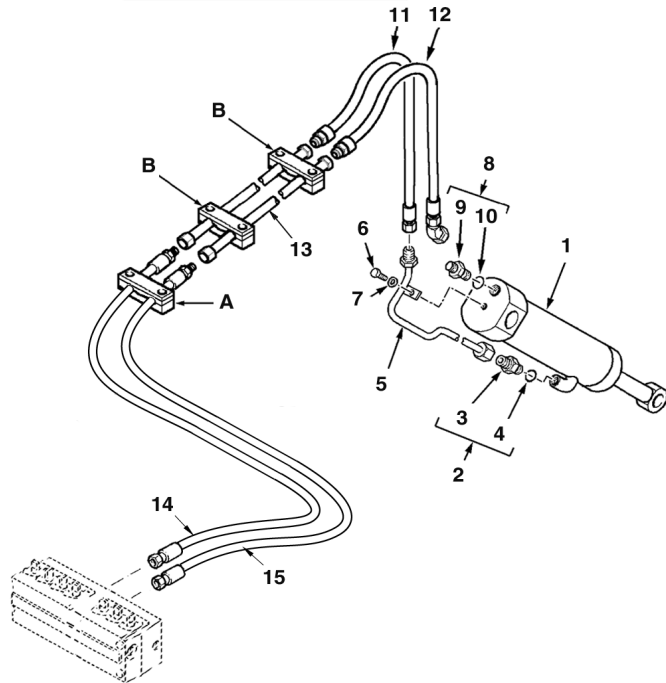
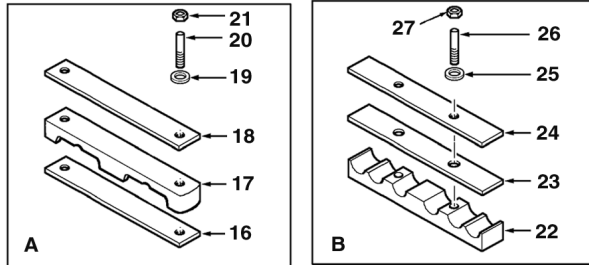

1	5000126M91	76034C02.1	1	Cylinder Assy	Ensemble de vérin	Gato, Conj.
2	835013M91		1	Connector Assy	Ensemble connexion	Conexión, Conj.
3		2 Ref. 2	1	Union	Union	Unión
4	835024M1	2	1	O-Ring	Joint torique	Junta de tipo O
5	6101540M91		1	Tube Assy	Tuyauterie	Conjunto de tubería
6	339123X1	M8 x 20	1	Bolt	Boulon	Perno
7	385361X1	M8	1	Washer	Rondelle	Arandela
8	835013M91		1	Connector Assy	Ensemble connexion	Conexión, Conj.
9		8 Ref. 8	1	Union	Union	Unión
10	835024M1	8	1	O-Ring	Joint torique	Junta de tipo O
11	6102309M91	Brown	1	Hose Assy	Ensemble de flexible	Flexible, Conj.
12	6107024M91	White	1	Hose Assy	Ensemble de flexible	Flexible, Conj.
13	6101771M91		2	Tube Assy	Tuyauterie	Conjunto de tubería
14	6108762M91	Brown	1	Hose Assy	Ensemble de flexible	Flexible, Conj.
15	6108763M91	White	1	Hose Assy	Ensemble de flexible	Flexible, Conj.
16	6102128M1		1	Pad	Plaque antidérapante	Cinta antideslizante
17	6102122M1		1	Bracket, Clamp	Bride de fixation	Brida de fijación
18	6102130M1		1	Plate	Plaque	Placa
19	390972X1	M8	2	Washer	Rondelle	Arandela
20	3516075M1	M8 x 65	2	Stud	Goujon	Espárrago
21	394367X1	M8	2	Nut, Lock	Écrou de blocage	Tuerca de retención
22	6102126M1		2	Bracket, Clamp	Bride de fixation	Brida de fijación
23	6102145M1		2	Pad	Plaque antidérapante	Cinta antideslizante
24	6102124M1		2	Plate	Plaque	Placa
25	390972X1	M8	4	Washer	Rondelle	Arandela
26	6108049M1		4	Stud	Goujon	Espárrago
27	394367X1	M8	4	Nut, Lock	Écrou de blocage	Tuerca de retención



820
 TX760B

805 806 807 808 833 834

76034C01.1

6199042M3

1

Jan-06

Digger Hydraulics
Circuit Hydraulique Défonceuse
Circuito hidráulico equipo retro

Sideshift
Montage de Pelle Latéral
Excavadora de montaje horizontal

Bucket Cylinder
Vérin de Godet
Gato de cuchara

Std. Spec.
 Std. Spec.
 Std. Spec.

C-76034-02.1-A

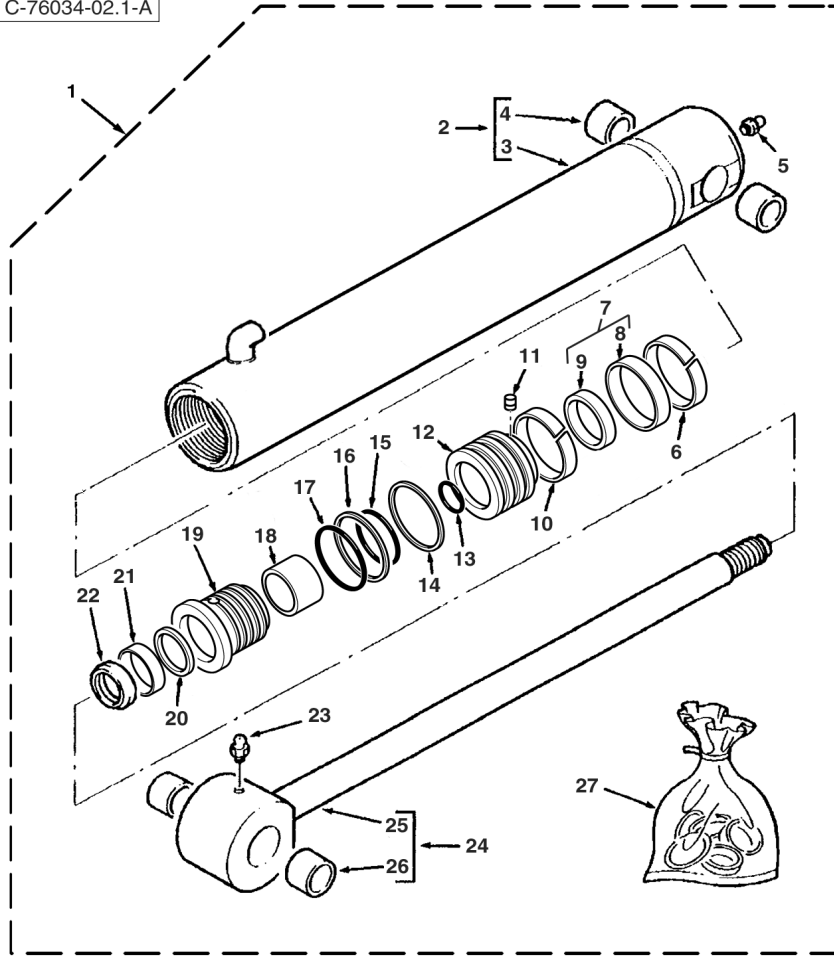

1	5000126M91		76034C01.1 1	1	Cylinder Assy	Ensemble de vérin	Gato, Conj.
2	5004008M91	1		1	Cylinder	Cylindre	Cilindro
3		3	Ref. 2	1	Tube, Cylinder	Cylindre de vérin	Cilindro de gato
4		3 (C)		1	Bushing	Bague	Anillo
5	339608X1	1		1	Fitting, Grease	Graisneur	Engrasador
6	3485892M1	1 (A)		1	Ring, Sealing	Bague d'étanchéité	Anillo, Estanqueidad
7	3485245M91	1 (A)		1	Seal Assy	Ensemble de joint	Junta, Conj.
8		7	Ref. 7	1	Seal	Joint	Junta
9		7	Ref. 7	1	Ring	Anneau	Aro
10	3485892M1	1 (A)		1	Ring, Sealing	Bague d'étanchéité	Anillo, Estanqueidad
11	3402928M1	1		1	Screw	Vis	Tornillo
12	3623372M1	1		1	Piston	Piston	Pistón
13	359186X1	1 (A)		1	O-Ring	Joint torique	Junta de tipo O
14	3623061M1	1		1	Ring, Piston	Segment de piston	Segmento de pistón
15	359193X1	1 (A)		1	O-Ring	Joint torique	Junta de tipo O
16	1606735M1	1 (A)		1	Ring, Backup	Contre-joint	ContraJunta
17	3487207M1	1 (A)		1	O-Ring	Joint torique	Junta de tipo O
18	3484615M1	1 (A)		1	Ring	Anneau	Aro
19	3623371M1	1		1	Bearing	Coussinet	Cojinete
20	3484055M1	1 (A)		1	Ring	Anneau	Aro
21	3485185M1	1 (A)		1	Seal	Joint	Junta
22	3487015M1	1 (A)		1	Ring	Anneau	Aro
23	339608X1	1		1	Fitting, Grease	Graisneur	Engrasador
24	5004012M91	1		1	Rod, Piston	Tige de vérin	Vástago cilindro
25		24	Ref. 24	1	Rod, Piston	Tige de vérin	Vástago cilindro
26		24 (C)		1	Bushing	Bague	Anillo
27	3623373M91		(B)	1	Kit, Seal	Pochette de joints	Juego de juntas

A Contains items marked (A)
 Comprend les pièces marquées (A)
 Incluye las piezas marcadas (A)
 C Part number to be advised
 Référence pièce à demander
 Indicar número de pieza

B Included in kit marked (B)
 Inclus dans jeu marqué (B)
 Incluido en juego marcado (B)



805 806 807 808 833 834

76034C02.1

6199042M3

1

Jan-06

Digger Hydraulics
Circuit Hydraulique Défonceuse
Circuito hidráulico equipo retro

Sideshift
Montage de Pelle Latéral
Excavadora de montaje horizontal

Standard Dipper
Balancier Standard
Balancín estándar

Std. Spec.
 Std. Spec.
 Std. Spec.

C-76034-03.1-A

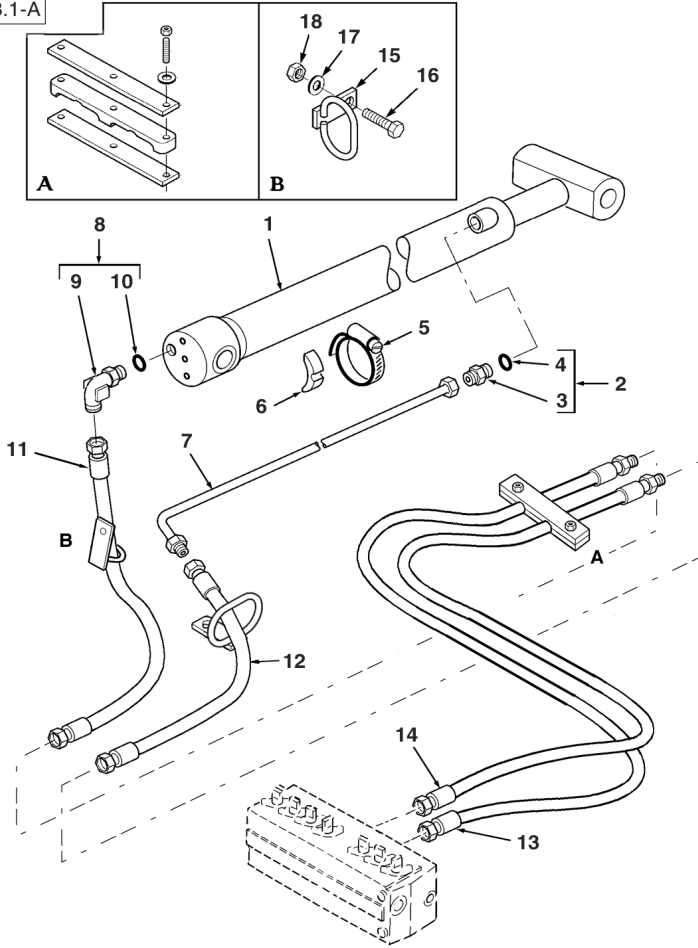

1	5000124M91	76034C04.1	1	Cylinder Assy	Ensemble de vérin	Gato, Conj.
2	835013M91		1	Connector Assy	Ensemble connexion	Conexión, Conj.
3		2	1	Union	Union	Unión
4	835024M1	2	1	O-Ring	Joint torique	Junta de tipo O
5	3517733M1		1	Clamp	Collier de serrage	Argolla de cierre
6	L79937		1	Spacer	Entretoise	Travesa
7		(A,B)	1	Tube Assy	Tuyauterie	Conjunto de tubería
8		(A,B)	1	Elbow	Coude	Codo
9		8 (A,B)	1	Elbow	Coude	Codo
10		8 (A,B)	1	O-Ring	Joint torique	Junta de tipo O
11	6101738M91	Yellow	1	Hose Assy	Ensemble de flexible	Flexible, Conj.
12	6101737M91	Red	1	Hose Assy	Ensemble de flexible	Flexible, Conj.
13	6108767M91	Yellow	1	Hose Assy	Ensemble de flexible	Flexible, Conj.
14	6108766M91	Red	1	Hose Assy	Ensemble de flexible	Flexible, Conj.
15	6101491M92		2	Support Assy	Ensemble de support	Apoyadero, Conj.
16	339761X1	M8 x 25	2	Screw	Vis	Tornillo
17	390972X1	M8	2	Washer	Rondelle	Arandela
18	394367X1	M8	2	Nut, Lock	Écrou de blocage	Tuerca de retención

A Without Hose Burst
 Sans éclatement de tuyau
 Sin rotura de tubo flexible

B See hose burst section
 Voir la section éclatement de tuyau
 Ver la sección de rotura de tubo flexible



820
 TX760B

805 806 807 808 833 834

76034C03.1

6199042M3

1

Jan-06

Digger Hydraulics
Circuit Hydraulique Défonceuse
Circuito hidráulico equipo retro

Sideshift
Montage de Pelle Latéral
Excavadora de montaje horizontal

Dipper Cylinder
Vérin de Balancier
Gato de balancín

Std. Spec.
 Std. Spec.
 Std. Spec.

C-76034-04.1-A

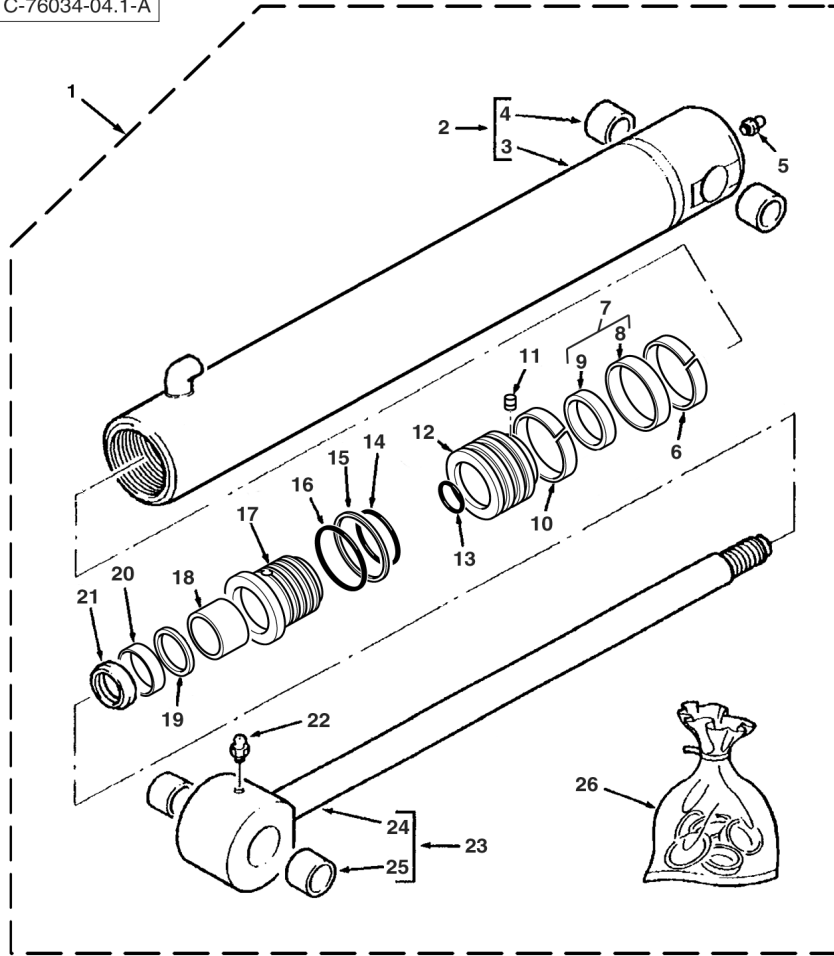

1	5000124M91	76034C03.1	1	Cylinder Assy	Ensemble de vérin	Gato, Conj.
2	5003982M91		1	Cylinder	Cylindre	Cilindro
3		Ref. 2	1	Tube, Cylinder	Cylindre de vérin	Cilindro de gato
4	3484843M1		2	Bush	Bague	Casquillo
5	339608X1		1	Fitting, Grease	Graisneur	Engrasador
6	3485891M1	(A)	1	Ring	Anneau	Aro
7	3485247M91	(A)	1	Seal Assy	Ensemble de joint	Junta, Conj.
8		Ref. 7	1	Seal	Joint	Junta
9		Ref. 7	1	Ring	Anneau	Aro
10	3485891M1	(A)	1	Ring	Anneau	Aro
11	3402928M1		1	Screw	Vis	Tornillo
12	5003989M1		1	Piston	Piston	Pistón
13	3007182X1	(A)	1	O-Ring	Joint torique	Junta de tipo O
14	359196X1	(A)	1	O-Ring	Joint torique	Junta de tipo O
15	378545X1	(A)	1	Ring	Anneau	Aro
16	3487908M1	(A)	1	O-Ring	Joint torique	Junta de tipo O
17	5003988M1		1	Bearing	Coussinet	Cojinete
18	3623193M1	(A)	1	Ring	Anneau	Aro
19	3443388M1	(A)	1	Ring	Anneau	Aro
20	3443472M1	(A)	1	Seal	Joint	Junta
21	3403385M1	(A)	1	Ring, Wiper	Joint de racler	Junta raspador
22	339608X1		1	Fitting, Grease	Graisneur	Engrasador
23	5003985M91		1	Rod, Piston	Tige de vérin	Vástago cilindro
24		Ref. 23	1	Rod, Piston	Tige de vérin	Vástago cilindro
25	3484843M1		23	Bush	Bague	Casquillo
26	5004401M91	(B)	1	Kit, Seal	Pochette de joints	Juego de juntas

A Included in kit marked (B)
 Inclus dans jeu marqué (B)
 Incluido en juego marcado (B)

B Contains items marked (A)
 Comprend les pièces marquées (A)
 Incluye las piezas marcadas (A)



820
 TX760B

805 806 807 808 833 834

76034C04.1

6199042M3

1

Jan-06

Digger Hydraulics
Circuit Hydraulique Défonceuse
Circuito hidráulico equipo retro

Sideshift
Montage de Pelle Latéral
Excavadora de montaje horizontal

Boom
 Flèche
 Pluma

Std. Spec.
 Std. Spec.
 Std. Spec.

C-76034-05.1-A

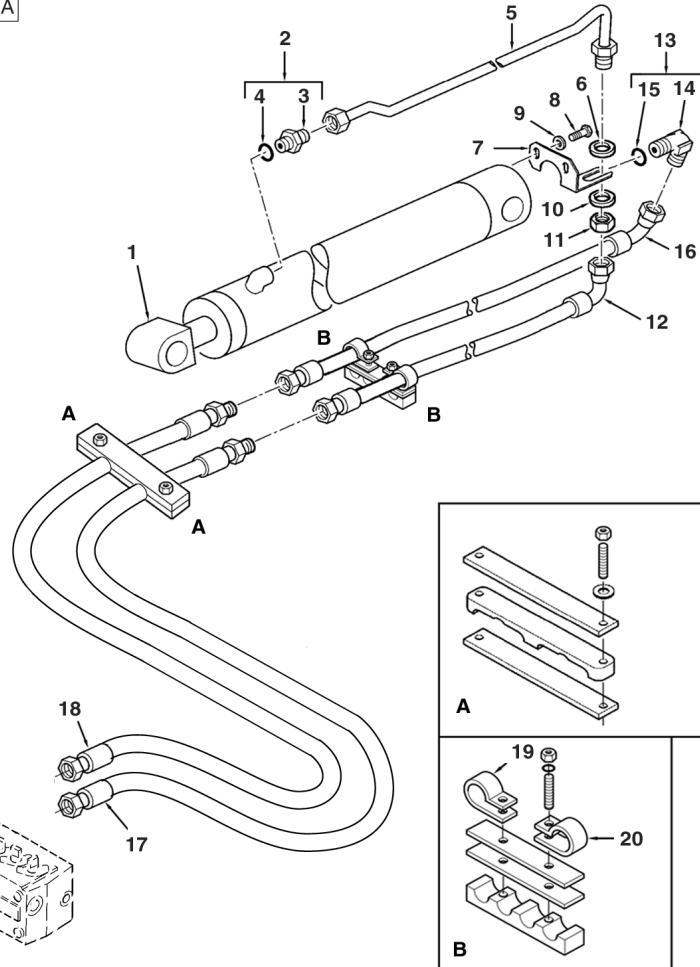

1	5000121M91	76034C06.1	1	Cylinder Assy	Ensemble de vérin	Gato, Conj.
2	835013M91		1	Connector Assy	Ensemble connexion	Conexión, Conj.
3		2	1	Union	Union	Unión
4	835024M1	2	1	O-Ring	Joint torique	Junta de tipo O
5		(A,B)	1	Tube Assy	Tuyauterie	Conjunto de tubería
6		(A,B)	1	Washer	Rondelle	Arandela
7		(A,B)	1	Bracket	Patte de fixation	Pata de fijación
8	339228X1	M8 x 12	2	Screw	Vis	Tornillo
9	339374X1	M8	2	Washer, Lock	Rondelle de blocage	Arandela de freno
10		(A,B)	1	Washer	Rondelle	Arandela
11		(A,B)	1	Nut	Écrou	Tuerca
12		(A,B) Orange	1	Hose Assy	Ensemble de flexible	Flexible, Conj.
13		(A,B)	1	Elbow	Coude	Codo
14		13 (A,B)	1	Elbow	Coude	Codo
15		13 (A,B)	1	O-Ring	Joint torique	Junta de tipo O
16	6101736M92	Blue	1	Hose Assy	Ensemble de flexible	Flexible, Conj.
17	6108761M91	Orange	1	Hose Assy	Ensemble de flexible	Flexible, Conj.
18	6108760M91	Blue	1	Hose Assy	Ensemble de flexible	Flexible, Conj.
19	515-23270		1	Clip	Clip	Clip
20	515-23206		1	Clip	Clip	Clip

A Without Hose Burst
 Sans éclatement de tuyau
 Sin rotura de tubo flexible

B See hose burst section
 Voir la section éclatement de tuyau
 Ver la sección de rotura de tubo flexible



820
 TX760B

805 806 807 808 833 834

76034C05.1

6199042M3

1

Jan-06

Digger Hydraulics
Circuit Hydraulique Défonceuse
Circuito hidráulico equipo retro

Sideshift
Montage de Pelle Latéral
Excavadora de montaje horizontal

Boom Cylinder
Vérin de Flèche
Gato de pluma

Std. Spec.
 Std. Spec.
 Std. Spec.

C-76034-06.1-A

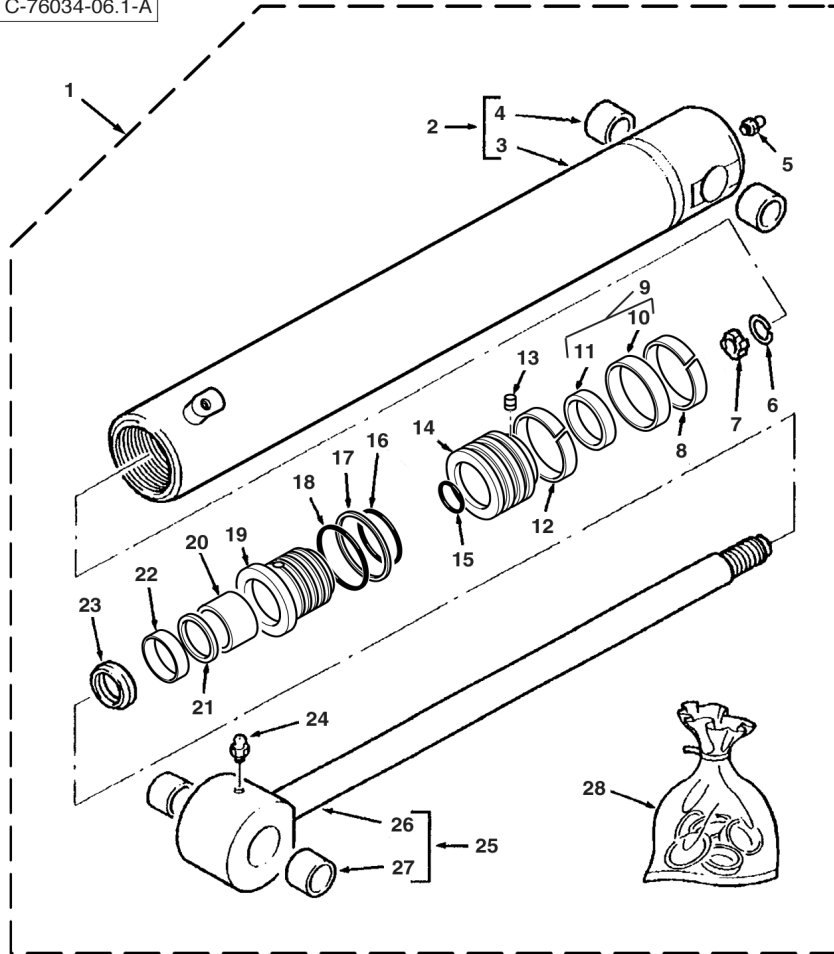

1	5000121M91	76034C05.1	1	Cylinder Assy	Ensemble de vérin	Gato, Conj.
2	5003974M91		1	Cylinder	Cylindre	Cilindro
3		2	Ref. 2	Tube, Cylinder	Cylindre de vérin	Cilindro de gato
4		2 (C)		Bushing	Bague	Anillo
5	339608X1	1		Fitting, Grease	Graisneur	Engrasador
6	1609899M1	1		Ring, Snap	Anneau d'arrêt	Anillo de resorte
7	1609328M1	1		Ring	Anneau	Aro
8	3442376M1	1 (A)	2	Ring	Anneau	Aro
9	3485249M91	1 (A)	1	Seal	Joint	Junta
10		9	Ref. 9	Seal	Joint	Junta
11		9	Ref. 9	Seal	Joint	Junta
13	3402928M1	1		Screw	Vis	Tornillo
14	5003980M1	1		Piston	Piston	Pistón
15	3007182X1	1 (A)	1	O-Ring	Joint torique	Junta de tipo O
16	359201X1	1 (A)	1	O-Ring	Joint torique	Junta de tipo O
17	1024334M1	1 (A)	1	Ring	Anneau	Aro
18	3487909M1	1 (A)	1	O-Ring	Joint torique	Junta de tipo O
19	5003979M1	1	1	Bearing	Coussinet	Cojinete
20	3623193M1	1 (A)	1	Ring	Anneau	Aro
21	3443388M1	1 (A)	1	Ring	Anneau	Aro
22	3443472M1	1 (A)	1	Seal	Joint	Junta
23	3403385M1	1 (A)	1	Ring, Wiper	Joint de racleur	Junta raspador
24	339608X1	1	1	Fitting, Grease	Graisneur	Engrasador
25	3441629M91	1	1	Rod, Piston	Tige de vérin	Vástago cilindro
26		25	Ref. 25	Rod, Piston	Tige de vérin	Vástago cilindro
27	3484843M1	25	1	Bush	Bague	Casquillo
28	5004400M91	(B)	1	Kit, Seal	Pochette de joints	Juego de juntas

A Included in kit marked (B)
 Inclus dans jeu marqué (B)
 Incluido en juego marcado (B)

C Part number to be advised
 Référence pièce à demander
 Indicar número de pieza

B Contains items marked (A)
 Comprend les pièces marquées (A)
 Incluye las piezas marcadas (A)



820
 TX760B

805 806 807 808 833 834

76034C06.1

6199042M3

1

Jan-06

Digger Hydraulics
Circuit Hydraulique Défonceuse
Circuito hidráulico equipo retro

Sideshift
Montage de Pelle Latéral
Excavadora de montaje horizontal

Swing Components
Organes de Rotation
Componentes de rotación

Std. Spec.
 Std. Spec.
 Std. Spec.

C-76034-07.1-A

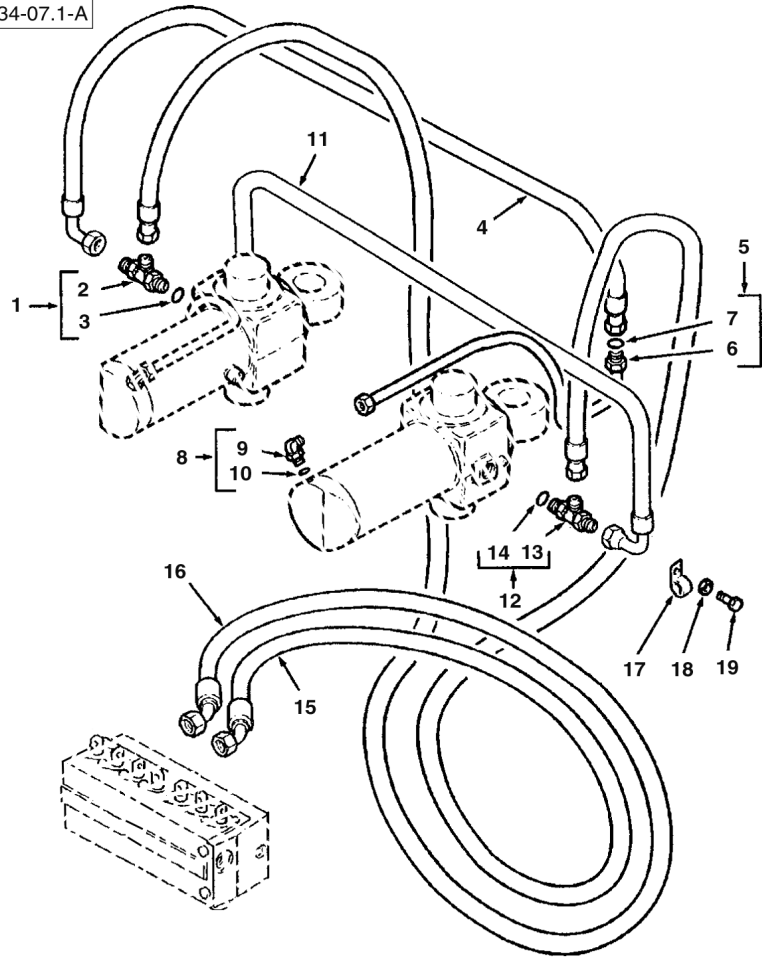

1	358728X91		1	Tee	Raccord en T	Te	
2		1	▶ Ref. 1	1	Tee	Raccord en T	Te
3	831497M1	1		1	O-Ring	Joint torique	Junta de tipo O
4	6100716M91	840 mm		1	Hose Assy	Ensemble de flexible	Flexible, Conj.
5	6100587M91	◀		1	Tube Assy	Tuyauterie	Conjunto de tubería
5	6100589M91	▶		1	Tube Assy	Tuyauterie	Conjunto de tubería
6		5	▶ Ref. 5	1	Tube	Tube	Tubo
7	394923X1	5		1	O-Ring	Joint torique	Junta de tipo O
8	357197X91			2	Elbow, 90°	Coude à 90°	Codo, 90°
9		8	▶ Ref. 8	1	Elbow	Coude	Codo
10	831452M1	8		1	O-Ring	Joint torique	Junta de tipo O
11	6100716M91	840 mm		1	Hose Assy	Ensemble de flexible	Flexible, Conj.
12	358728X91			1	Tee	Raccord en T	Te
13		12	▶ Ref. 12	1	Tee	Raccord en T	Te
14	831497M1	12		1	O-Ring	Joint torique	Junta de tipo O
15	6107456M91	◀ 1745 mm		1	Hose Assy	Ensemble de flexible	Flexible, Conj.
16	6107455M91	▶ 1745 mm		1	Hose Assy	Ensemble de flexible	Flexible, Conj.
17	3517114M2			2	Clip, Mounting	Collier de fixation	Argolla de fijación
18	385361X1	M8		2	Washer	Rondelle	Arandela
19	339228X1	M8 x 12		2	Screw	Vis	Tornillo



820
TX760B

805 806 807 808 833 834

76034C07.1

6199042M3

1

Jan-06

Digger Hydraulics
 Circuit Hydraulique Défonceuse
 Circuito hidráulico equipo retro

Sideshift
 Montage de Pelle Latéral
 Excavadora de montaje horizontal

Clamp
 Collier
 Abrazadera

Std. Spec.
 Std. Spec.
 Std. Spec.

C-76034-08-1-A

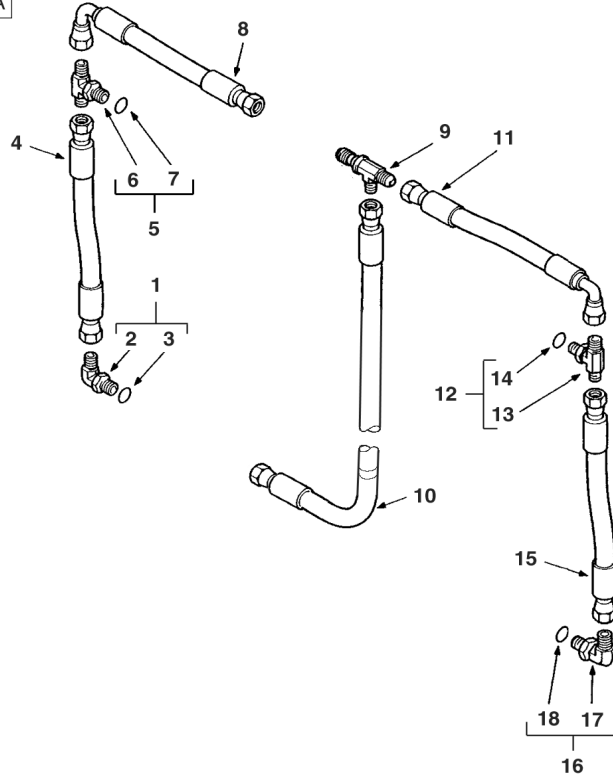

1	358761X91			1	Elbow, 90°	Coude à 90°	Codo, 90°
2		1	▶ Ref. 1	1	Elbow	Coude	Codo
3	831496M1	1		1	O-Ring	Joint torique	Junta de tipo O
4	3521882M94			1	Hose Assy	Ensemble de flexible	Flexible, Conj.
5	358827X91			1	Tee	Raccord en T	Te
6		5	▶ Ref. 5	1	Tee	Raccord en T	Te
7	831496M1	5		1	O-Ring	Joint torique	Junta de tipo O
8	3521878M93			1	Hose Assy	Ensemble de flexible	Flexible, Conj.
9	356558X1			1	Tee	Raccord en T	Te
10	6110207M91	Clamp		1	Hose Assy	Ensemble de flexible	Flexible, Conj.
11	3521878M93			1	Hose Assy	Ensemble de flexible	Flexible, Conj.
12	358827X91			1	Tee	Raccord en T	Te
13		12	▶ Ref. 12	1	Tee	Raccord en T	Te
14	831496M1	12		1	O-Ring	Joint torique	Junta de tipo O
15	3521882M94			1	Hose Assy	Ensemble de flexible	Flexible, Conj.
16	358761X91			1	Elbow, 90°	Coude à 90°	Codo, 90°
17		16	▶ Ref. 16	1	Elbow	Coude	Codo
18	831496M1	16		1	O-Ring	Joint torique	Junta de tipo O



820
 TX760B

805 806 807 808 833 834

76034C08.1

6199042M3

1

Jan-06

Digger Hydraulics
Circuit Hydraulique Défonceuse
Circuito hidráulico equipo retro

Sideshift
Montage de Pelle Latéral
Excavadora de montaje horizontal

Attachment
Attache
Equipo

C-76034-09.1-A

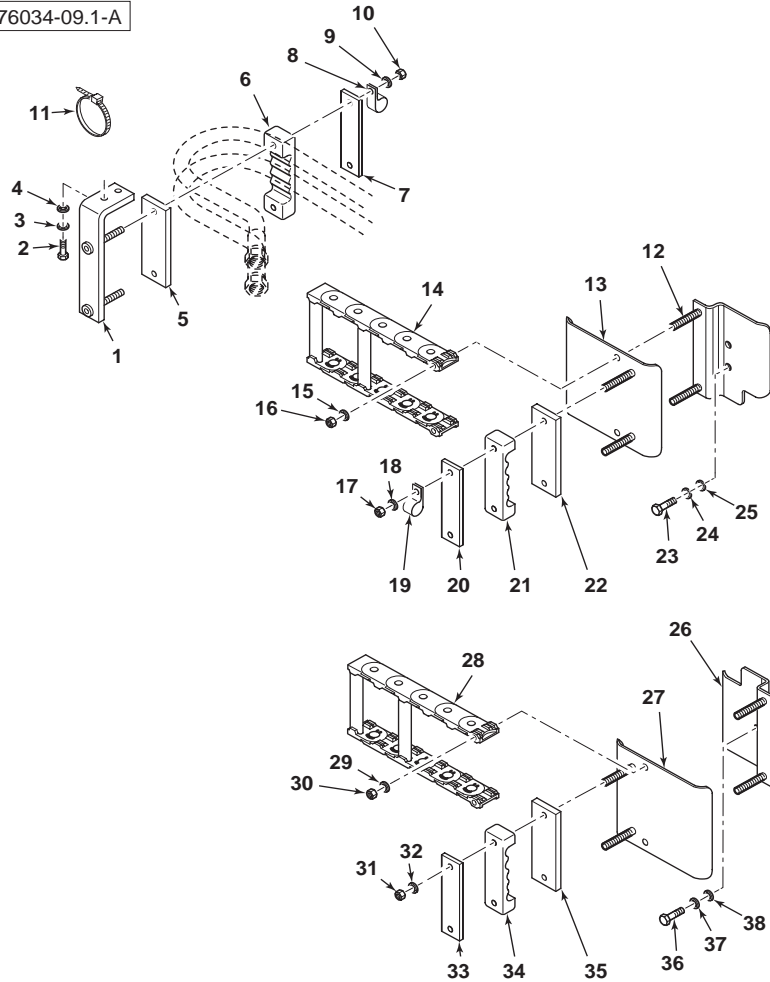

1	6107934M91		2	Bracket, Clamp	Bride de fixation	Brida de fijación
2	339761X1	M8 x 25	4	Screw	Vis	Tornillo
3	390972X1	M8	4	Washer	Rondelle	Arandela
4	339374X1	M8	4	Washer, Lock	Rondelle de blocage	Arandela de freno
5	6102197M1		2	Pad, Rubber	Plaque de caoutchouc	Placa, Caucho
6	6101216M1	◀	1	Clamp	Collier de serrage	Argolla de cierre
6	6101859M1	▶	1	Clamp	Collier de serrage	Argolla de cierre
7	6101215M1		2	Plate	Plaque	Placa
8	515-22159		1	Clip, Mounting	Collier de fixation	Argolla de fijación
9	390972X1	M8	4	Washer	Rondelle	Arandela
10	394367X1	M8	4	Nut, Lock	Écrou de blocage	Tuerca de retención
11	1862425M1		1	Tie, Cable	Attache câble	Enlace de Cable
12	6102307M91	▶	1	Bracket, Clamp	Bride de fixation	Brida de fijación
13	6101424M91		1	Plate Assy	Ensemble de plaque	Placa, Conj.
14	6102199M92		1	Chain	Chaîne	Cadena
15	390971X1	M6	2	Washer	Rondelle	Arandela
16	1441500X1	M6	2	Nut, Lock	Écrou de blocage	Tuerca de retención
17	394367X1	M8	2	Nut, Lock	Écrou de blocage	Tuerca de retención
18	390972X1	M8	2	Washer	Rondelle	Arandela
19	515-22159		1	Clip, Mounting	Collier de fixation	Argolla de fijación
20	6101215M1		1	Plate	Plaque	Placa
21	6101859M1		1	Clamp	Collier de serrage	Argolla de cierre
22	6102197M1		1	Pad, Rubber	Plaque de caoutchouc	Placa, Caucho
23	3009492X1	M10 x 25	2	Screw	Vis	Tornillo
24	339376X1	M10	2	Washer, Lock	Rondelle de blocage	Arandela de freno
25	390734X1	M10	2	Washer	Rondelle	Arandela
26	6102308M91	◀	1	Bracket, Clamp	Bride de fixation	Brida de fijación
27	6101424M91		1	Plate Assy	Ensemble de plaque	Placa, Conj.
28	6102199M92		1	Chain	Chaîne	Cadena
29	390971X1	M6	2	Washer	Rondelle	Arandela
30	1441500X1	M6	2	Nut, Lock	Écrou de blocage	Tuerca de retención
31	394367X1	M8	2	Nut, Lock	Écrou de blocage	Tuerca de retención
32	390972X1	M8	2	Washer	Rondelle	Arandela
33	6101215M1		1	Plate	Plaque	Placa
34	6101216M1	◀	1	Clamp	Collier de serrage	Argolla de cierre
35	6102197M1		1	Pad, Rubber	Plaque de caoutchouc	Placa, Caucho
36	3009492X1	M10 x 25	2	Screw	Vis	Tornillo
37	339376X1	M10	2	Washer, Lock	Rondelle de blocage	Arandela de freno
38	390734X1	M10	2	Washer	Rondelle	Arandela



820
TX760B

805 806 807 808 833 834

76034C09.1

6199042M3

1

Jan-06

Digger Hydraulics
Circuit Hydraulique Défonceuse
Circuito hidráulico equipo retro

Sideshift
Montage de Pelle Latéral
Excavadora de montaje horizontal

Bucket
 Godet
 Cuchara

Std. Spec.
 Std. Spec.
 Std. Spec.

C-76035-01.1-A

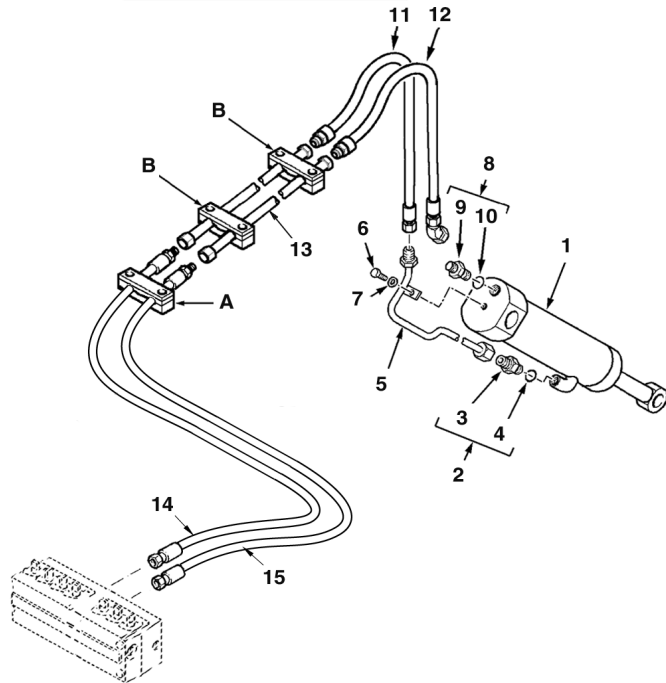
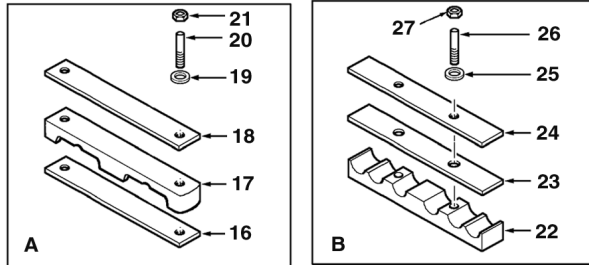

1	5000126M91	76035C02.1	1	Cylinder Assy	Ensemble de vérin	Gato, Conj.
2	835013M91		1	Connector Assy	Ensemble connexion	Conexión, Conj.
3		2 Ref. 2	1	Union	Union	Unión
4	835024M1	2	1	O-Ring	Joint torique	Junta de tipo O
5	6101540M91		1	Tube Assy	Tuyauterie	Conjunto de tubería
6	339123X1	M8 x 20	1	Bolt	Boulon	Perno
7	385361X1	M8	1	Washer	Rondelle	Arandela
8	835013M91		1	Connector Assy	Ensemble connexion	Conexión, Conj.
9		8 Ref. 8	1	Union	Union	Unión
10	835024M1	8	1	O-Ring	Joint torique	Junta de tipo O
11		(A)Brown	1	Hose Assy	Ensemble de flexible	Flexible, Conj.
12		(A)White	1	Hose Assy	Ensemble de flexible	Flexible, Conj.
13	6101771M91		2	Tube Assy	Tuyauterie	Conjunto de tubería
14	6108762M91	Brown	1	Hose Assy	Ensemble de flexible	Flexible, Conj.
15	6108763M91	White	1	Hose Assy	Ensemble de flexible	Flexible, Conj.
16	6102128M1		1	Pad	Plaque antidérapante	Cinta antideslizante
17	6102122M1		1	Bracket, Clamp	Bride de fixation	Brida de fijación
18	6102130M1		1	Plate	Plaque	Placa
19	390972X1	M8	2	Washer	Rondelle	Arandela
20	3516075M1	M8 x 65	2	Stud	Goujon	Espárrago
21	394367X1	M8	2	Nut, Lock	Écrou de blocage	Tuerca de retención
22	6102126M1		2	Bracket, Clamp	Bride de fixation	Brida de fijación
23	6102145M1		2	Pad	Plaque antidérapante	Cinta antideslizante
24	6102124M1		2	Plate	Plaque	Placa
25	390972X1	M8	4	Washer	Rondelle	Arandela
26	6108049M1		4	Stud	Goujon	Espárrago
27	394367X1	M8	4	Nut, Lock	Écrou de blocage	Tuerca de retención

A See extendahoe hydraulics section
 Voir la section circuit hydraulique extendahoe
 Ver la sección de la circuito hidráulico extendahoe



820
 TX760B

805 806 807 808 833 834

76035C01.1

6199042M3

1

Jan-06

Digger Hydraulics
Circuit Hydraulique Défonceuse
Circuito hidráulico equipo retro

Sideshift
Montage de Pelle Latéral
Excavadora de montaje horizontal

Bucket Cylinder
Vérin de Godet
Gato de cuchara

Std. Spec.
 Std. Spec.
 Std. Spec.

C-76035-02.1-A

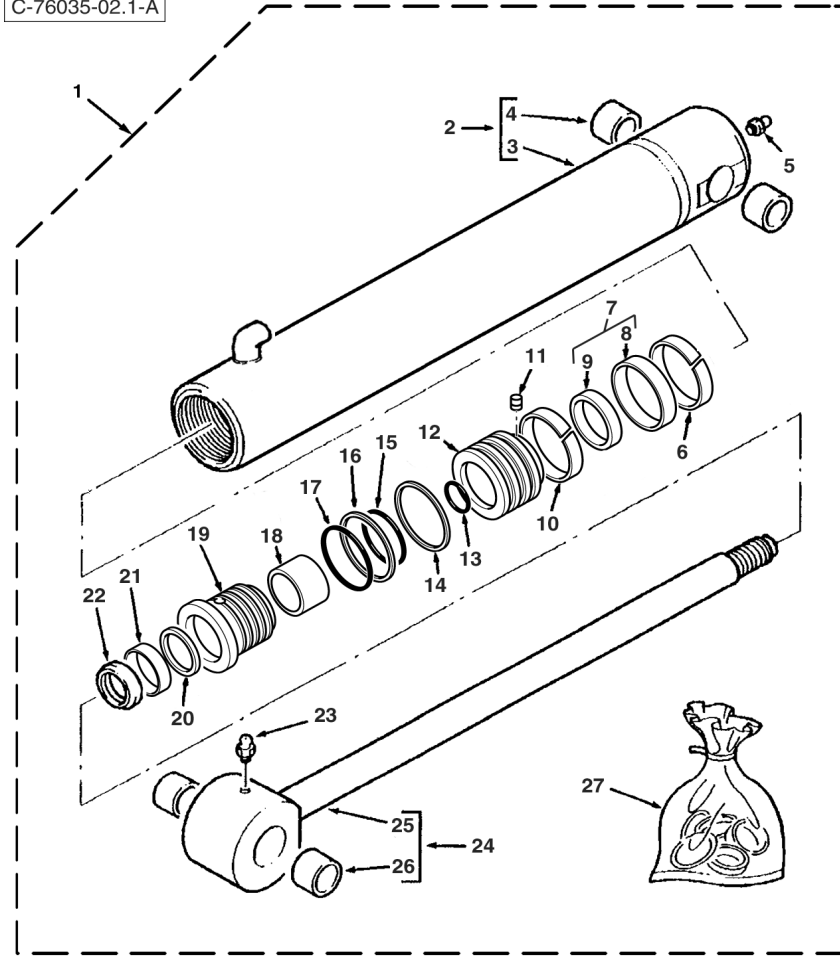

1	5000126M91		76035C01.1	1	Cylinder Assy	Ensemble de vérin	Gato, Conj.
2	5004008M91	1		1	Cylinder	Cylindre	Cilindro
3		3	Ref. 2	1	Tube, Cylinder	Cylindre de vérin	Cilindro de gato
4		3 (C)		1	Bushing	Bague	Anillo
5	339608X1	1		1	Fitting, Grease	Graisneur	Engrasador
6	3485892M1	1 (A)		1	Ring, Sealing	Bague d'étanchéité	Anillo, Estanqueidad
7	3485245M91	1 (A)		1	Seal Assy	Ensemble de joint	Junta, Conj.
8		7	Ref. 7	1	Seal	Joint	Junta
9		7	Ref. 7	1	Ring	Anneau	Aro
10	3485892M1	1 (A)		1	Ring, Sealing	Bague d'étanchéité	Anillo, Estanqueidad
11	3402928M1	1		1	Screw	Vis	Tornillo
12	3623372M1	1		1	Piston	Piston	Pistón
13	359186X1	1 (A)		1	O-Ring	Joint torique	Junta de tipo O
14	3623061M1	1		1	Ring, Piston	Segment de piston	Segmento de pistón
15	359193X1	1 (A)		1	O-Ring	Joint torique	Junta de tipo O
16	1606735M1	1 (A)		1	Ring, Backup	Contre-joint	ContraJunta
17	3487207M1	1 (A)		1	O-Ring	Joint torique	Junta de tipo O
18	3484615M1	1 (A)		1	Ring	Anneau	Aro
19	3623371M1	1		1	Bearing	Coussinet	Cojinete
20	3484055M1	1 (A)		1	Ring	Anneau	Aro
21	3485185M1	1 (A)		1	Seal	Joint	Junta
22	3487015M1	1 (A)		1	Ring	Anneau	Aro
23	339608X1	1		1	Fitting, Grease	Graisneur	Engrasador
24	5004012M91	1		1	Rod, Piston	Tige de vérin	Vástago cilindro
25		24	Ref. 24	1	Rod, Piston	Tige de vérin	Vástago cilindro
26		24 (C)		1	Bushing	Bague	Anillo
27	3623373M91		(B)	1	Kit, Seal	Pochette de joints	Juego de juntas

A Contains items marked (A)
 Comprend les pièces marquées (A)
 Incluye las piezas marcadas (A)
 C Part number to be advised
 Référence pièce à demander
 Indicar número de pieza

B Included in kit marked (B)
 Inclus dans jeu marqué (B)
 Incluido en juego marcado (B)



805 806 807 808 833 834

76035C02.1

6199042M3

1

Jan-06

Digger Hydraulics
Circuit Hydraulique Défonceuse
Circuito hidráulico equipo retro

Sideshift
Montage de Pelle Latéral
Excavadora de montaje horizontal

Telescopic Dipper
Balancier Téléscopique
Balancín telescópico

Std. Spec.
 Std. Spec.
 Std. Spec.

C-76035-03.1-A

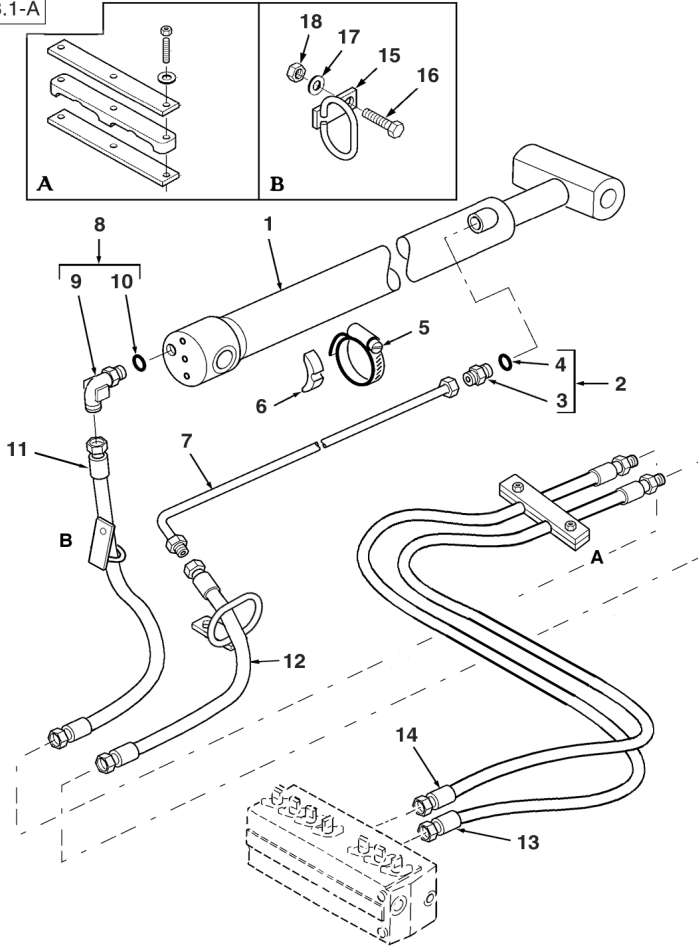

1	5000124M91	76035C04.1	1	Cylinder Assy	Ensemble de vérin	Gato, Conj.
2	835013M91		1	Connector Assy	Ensemble connexion	Conexión, Conj.
3		2 Ref. 2	1	Union	Union	Unión
4	835024M1	2	1	O-Ring	Joint torique	Junta de tipo O
5	3517733M1		1	Clamp	Collier de serrage	Argolla de cierre
6	L79937		1	Spacer	Entretoise	Travesa
7		(A,B)	1	Tube Assy	Tuyauterie	Conjunto de tubería
8		(A,B)	1	Elbow	Coude	Codo
9		8 (A,B) Ref. 8	1	Elbow	Coude	Codo
10		8 (A,B)	1	O-Ring	Joint torique	Junta de tipo O
11	6101738M91	Yellow	1	Hose Assy	Ensemble de flexible	Flexible, Conj.
12	6101737M91	Red	1	Hose Assy	Ensemble de flexible	Flexible, Conj.
13	6108767M91	Yellow	1	Hose Assy	Ensemble de flexible	Flexible, Conj.
14	6108766M91	Red	1	Hose Assy	Ensemble de flexible	Flexible, Conj.
15	6101491M92		2	Support Assy	Ensemble de support	Apoyadero, Conj.
16	339761X1	M8 x 25	2	Screw	Vis	Tornillo
17	390972X1	M8	2	Washer	Rondelle	Arandela
18	394367X1	M8	2	Nut, Lock	Écrou de blocage	Tuerca de retención

A Without Hose Burst
 Sans éclatement de tuyau
 Sin rotura de tubo flexible

B See hose burst section
 Voir la section éclatement de tuyau
 Ver la sección de rotura de tubo flexible



820
 TX760B

805 806 807 808 833 834

76035C03.1

6199042M3

1

Jan-06

Digger Hydraulics
Circuit Hydraulique Défonceuse
Circuito hidráulico equipo retro

Sideshift
Montage de Pelle Latéral
Excavadora de montaje horizontal

Dipper Cylinder
Vérin de Balancier
Gato de balancín

Std. Spec.
 Std. Spec.
 Std. Spec.

C-76035-04.1-A

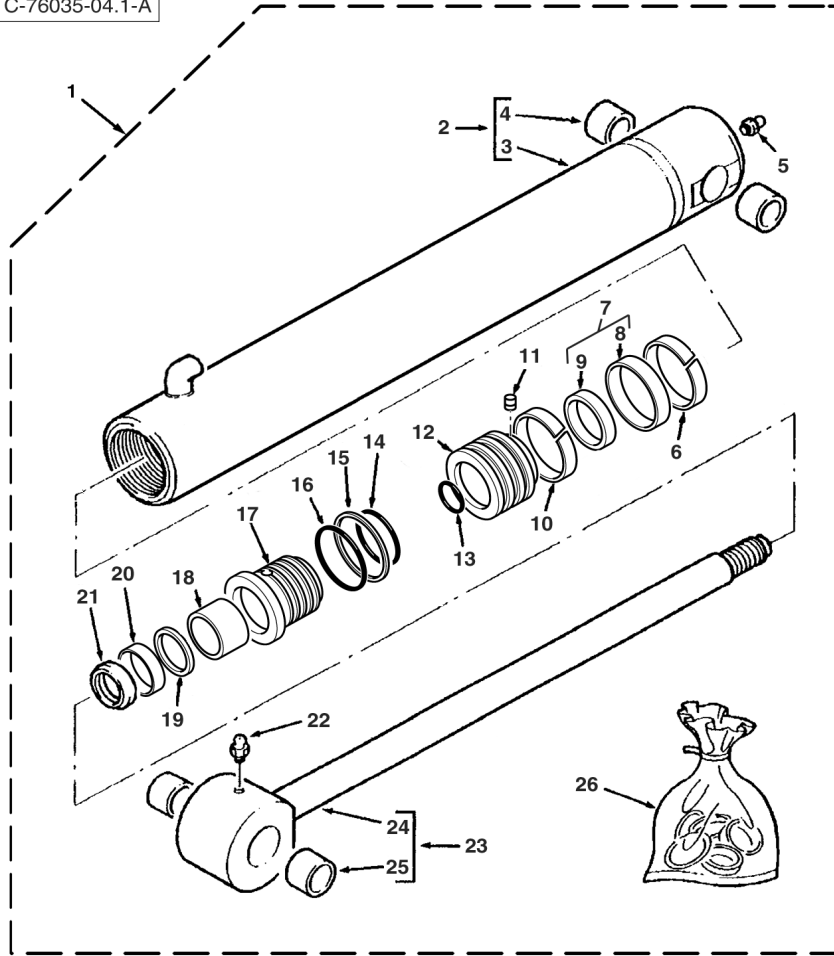

1	5000124M91		76035C03.1 1	1	Cylinder Assy	Ensemble de vérin	Gato, Conj.
2	5003982M91	1		1	Cylinder	Cylindre	Cilindro
3		2	Ref. 2	1	Tube, Cylinder	Cylindre de vérin	Cilindro de gato
4	3484843M1	2		1	Bush	Bague	Casquillo
5	339608X1	1		1	Fitting, Grease	Graisneur	Engrasador
6	3485891M1	1 (A)		1	Ring	Anneau	Aro
7	3485247M91	1 (A)		1	Seal Assy	Ensemble de joint	Junta, Conj.
8		7	Ref. 7	1	Seal	Joint	Junta
9		7	Ref. 7	1	Ring	Anneau	Aro
10	3485891M1	1 (A)		1	Ring	Anneau	Aro
11	3402928M1	1		1	Screw	Vis	Tornillo
12	5003989M1	1		1	Piston	Piston	Pistón
13	3007182X1	1 (A)		1	O-Ring	Joint torique	Junta de tipo O
14	359196X1	1 (A)		1	O-Ring	Joint torique	Junta de tipo O
15	378545X1	1 (A)		1	Ring	Anneau	Aro
16	3487908M1	1 (A)		1	O-Ring	Joint torique	Junta de tipo O
17	5003988M1	1		1	Bearing	Coussinet	Cojinete
18	3623193M1	1 (A)		1	Ring	Anneau	Aro
19	3443388M1	1 (A)		1	Ring	Anneau	Aro
20	3443472M1	1 (A)		1	Seal	Joint	Junta
21	3403385M1	1 (A)		1	Ring, Wiper	Joint de racler	Junta raspador
22	339608X1	1		1	Fitting, Grease	Graisneur	Engrasador
23	5003985M91	1		1	Rod, Piston	Tige de vérin	Vástago cilindro
24		23	Ref. 23	1	Rod, Piston	Tige de vérin	Vástago cilindro
25	3484843M1	23		1	Bush	Bague	Casquillo
26	5004401M91		(B)	1	Kit, Seal	Pochette de joints	Juego de juntas

A Included in kit marked (B)
 Inclus dans jeu marqué (B)
 Incluido en juego marcado (B)

B Contains items marked (A)
 Comprend les pièces marquées (A)
 Incluye las piezas marcadas (A)



820
 TX760B

805 806 807 808 833 834

76035C04.1

6199042M3

1

Jan-06

Digger Hydraulics
Circuit Hydraulique Défonceuse
Circuito hidráulico equipo retro

Sideshift
Montage de Pelle Latéral
Excavadora de montaje horizontal

Boom
 Flèche
 Pluma

Std. Spec.
 Std. Spec.
 Std. Spec.

C-76035-05.1-A

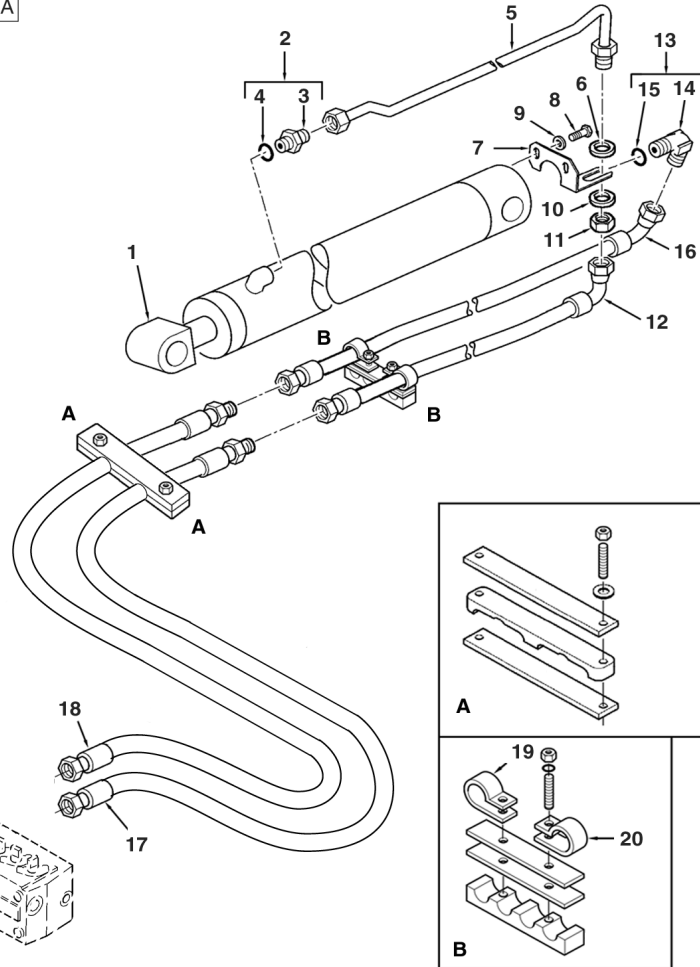

1	5000121M91	76035C06.1 1	1	Cylinder Assy	Ensemble de vérin	Gato, Conj.
2	835013M91		1	Connector Assy	Ensemble connexion	Conexión, Conj.
3		2 Ref. 2	1	Union	Union	Unión
4	835024M1	2	1	O-Ring	Joint torique	Junta de tipo O
5		(A,B)	1	Tube Assy	Tuyauterie	Conjunto de tubería
6		(A,B)	1	Washer	Rondelle	Arandela
7		(A,B)	1	Bracket	Patte de fixation	Pata de fijación
8	339228X1	M8 x 12	2	Screw	Vis	Tornillo
9	339374X1	M8	2	Washer, Lock	Rondelle de blocage	Arandela de freno
10		(A,B)	1	Washer	Rondelle	Arandela
11		(A,B)	1	Nut	Écrou	Tuerca
12		(A,B) Orange	1	Hose Assy	Ensemble de flexible	Flexible, Conj.
13		(A,B)	1	Elbow	Coude	Codo
14		13 (A,B)	1	Elbow	Coude	Codo
15		13 (A,B) Ref. 13	1	O-Ring	Joint torique	Junta de tipo O
16	6101736M92	Blue	1	Hose Assy	Ensemble de flexible	Flexible, Conj.
17	6108761M91	Orange	1	Hose Assy	Ensemble de flexible	Flexible, Conj.
18	6108760M91	Blue	1	Hose Assy	Ensemble de flexible	Flexible, Conj.
19	515-23270		1	Clip	Clip	Clip
20	515-23206		1	Clip	Clip	Clip

A Without Hose Burst
 Sans éclatement de tuyau
 Sin rotura de tubo flexible

B See hose burst section
 Voir la section éclatement de tuyau
 Ver la sección de rotura de tubo flexible



820
 TX760B

805 806 807 808 833 834

76035C05.1

6199042M3

1

Jan-06

Digger Hydraulics
Circuit Hydraulique Défonceuse
Circuito hidráulico equipo retro

Sideshift
Montage de Pelle Latéral
Excavadora de montaje horizontal

Boom Cylinder
Vérin de Flèche
Gato de pluma

Std. Spec.
 Std. Spec.
 Std. Spec.

C-76035-06.1-A

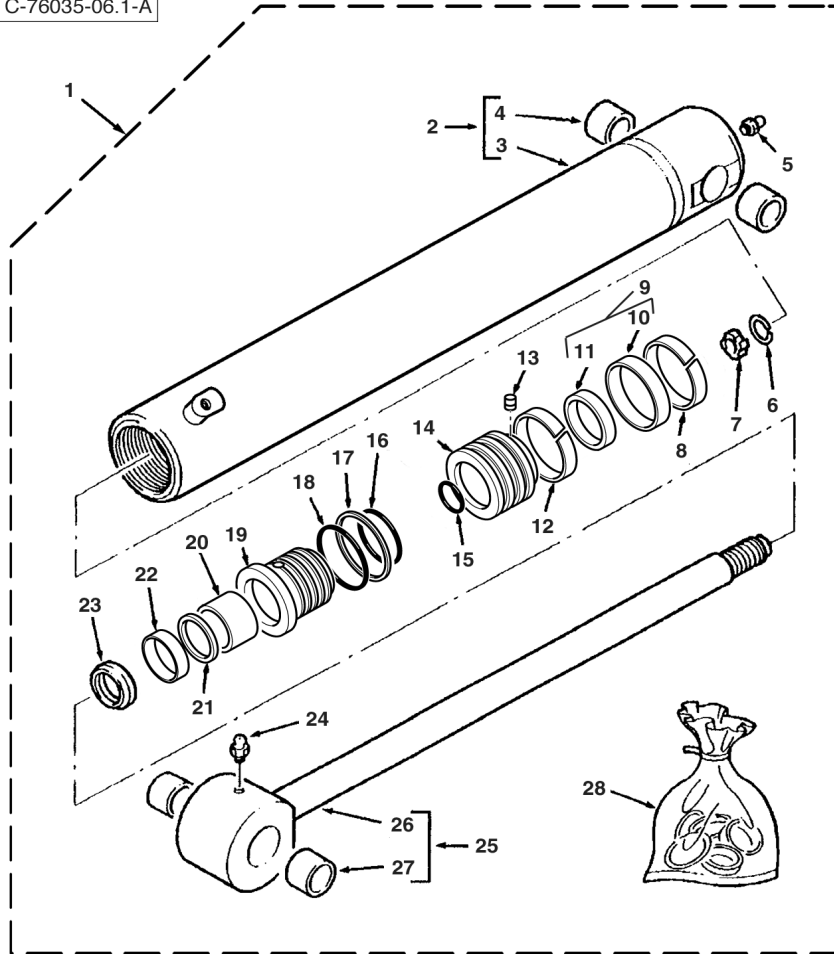

1	5000121M91	76035C05.1	1	Cylinder Assy	Ensemble de vérin	Gato, Conj.
2	5003974M91		1	Cylinder	Cylindre	Cilindro
3		2	Ref. 2	Tube, Cylinder	Cylindre de vérin	Cilindro de gato
4		2 (C)		Bushing	Bague	Anillo
5	339608X1	1		Fitting, Grease	Graisneur	Engrasador
6	1609899M1	1		Ring, Snap	Anneau d'arrêt	Anillo de resorte
7	1609328M1	1		Ring	Anneau	Aro
8	3442376M1	1 (A)	2	Ring	Anneau	Aro
9	3485249M91	1 (A)	1	Seal	Joint	Junta
10		9	Ref. 9	Seal	Joint	Junta
11		9	Ref. 9	Seal	Joint	Junta
13	3402928M1	1		Screw	Vis	Tornillo
14	5003980M1	1		Piston	Piston	Pistón
15	3007182X1	1 (A)	1	O-Ring	Joint torique	Junta de tipo O
16	359201X1	1 (A)	1	O-Ring	Joint torique	Junta de tipo O
17	1024334M1	1 (A)	1	Ring	Anneau	Aro
18	3487909M1	1 (A)	1	O-Ring	Joint torique	Junta de tipo O
19	5003979M1	1		Bearing	Coussinet	Cojinete
20	3623193M1	1 (A)	1	Ring	Anneau	Aro
21	3443388M1	1 (A)	1	Ring	Anneau	Aro
22	3443472M1	1 (A)	1	Seal	Joint	Junta
23	3403385M1	1 (A)	1	Ring, Wiper	Joint de racleur	Junta raspador
24	339608X1	1		Fitting, Grease	Graisneur	Engrasador
25	3441629M91	1		Rod, Piston	Tige de vérin	Vástago cilindro
26		25	Ref. 25	Rod, Piston	Tige de vérin	Vástago cilindro
27	3484843M1	25		Bush	Bague	Casquillo
28	5004400M91	(B)	1	Kit, Seal	Pochette de joints	Juego de juntas

A Included in kit marked (B)
 Inclus dans jeu marqué (B)
 Incluido en juego marcado (B)

C Part number to be advised
 Référence pièce à demander
 Indicar número de pieza

B Contains items marked (A)
 Comprend les pièces marquées (A)
 Incluye las piezas marcadas (A)



820
 TX760B

805 806 807 808 833 834

76035C06.1

6199042M3

1

Jan-06

Digger Hydraulics
Circuit Hydraulique Défonceuse
Circuito hidráulico equipo retro

Sideshift
Montage de Pelle Latéral
Excavadora de montaje horizontal

Swing Components
Organes de Rotation
Componentes de rotación

Std. Spec.
 Std. Spec.
 Std. Spec.

C-76035-07.1-A

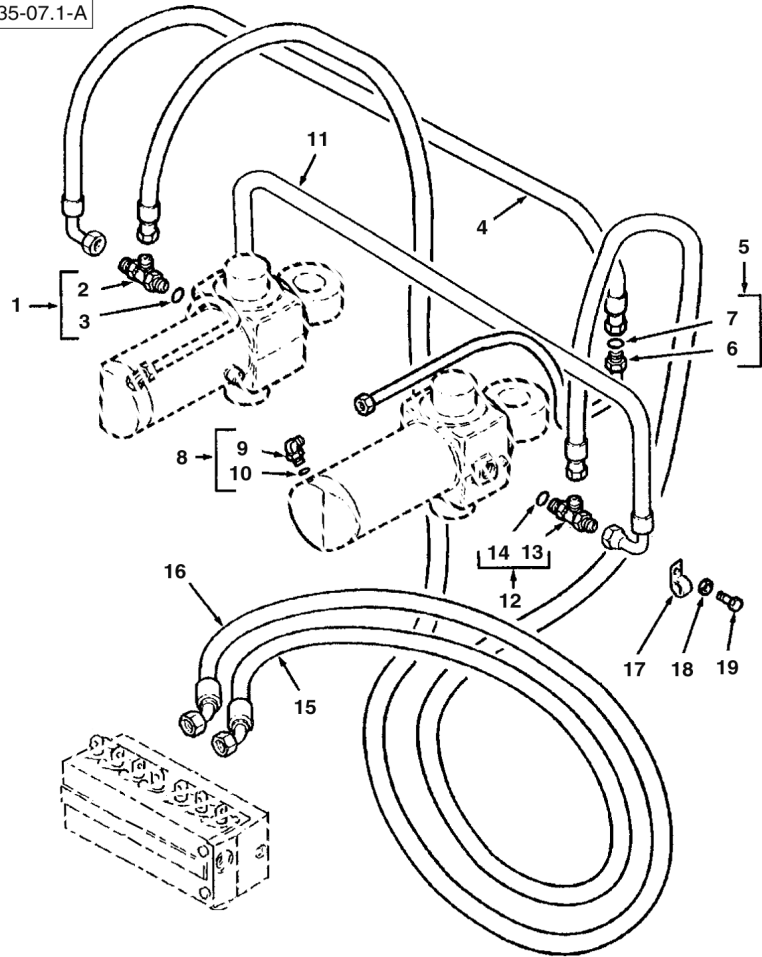

1	358728X91		1	Tee	Raccord en T	Te	
2		1	▶ Ref. 1	1	Tee	Raccord en T	Te
3	831497M1	1		1	O-Ring	Joint torique	Junta de tipo O
4	6100716M91	840 mm		1	Hose Assy	Ensemble de flexible	Flexible, Conj.
5	6100587M91	◀		1	Tube Assy	Tuyauterie	Conjunto de tubería
5	6100589M91	▶		1	Tube Assy	Tuyauterie	Conjunto de tubería
6		5	▶ Ref. 5	1	Tube	Tube	Tubo
7	394923X1	5		1	O-Ring	Joint torique	Junta de tipo O
8	357197X91			2	Elbow, 90°	Coude à 90°	Codo, 90°
9		8	▶ Ref. 8	1	Elbow	Coude	Codo
10	831452M1	8		1	O-Ring	Joint torique	Junta de tipo O
11	6100716M91	840 mm		1	Hose Assy	Ensemble de flexible	Flexible, Conj.
12	358728X91			1	Tee	Raccord en T	Te
13		12	▶ Ref. 12	1	Tee	Raccord en T	Te
14	831497M1	12		1	O-Ring	Joint torique	Junta de tipo O
15	6107456M91	◀ 1745 mm		1	Hose Assy	Ensemble de flexible	Flexible, Conj.
16	6107455M91	▶ 1745 mm		1	Hose Assy	Ensemble de flexible	Flexible, Conj.
17	3517114M2			2	Clip, Mounting	Collier de fixation	Argolla de fijación
18	385361X1	M8		2	Washer	Rondelle	Arandela
19	339228X1	M8 x 12		2	Screw	Vis	Tornillo



820
TX760B

805 806 807 808 833 834

76035C07.1

6199042M3

1

Jan-06

Digger Hydraulics
Circuit Hydraulique Défonceuse
Circuito hidráulico equipo retro

Sideshift
Montage de Pelle Latéral
Excavadora de montaje horizontal

Clamp
 Collier
 Abrazadera

Std. Spec.
 Std. Spec.
 Std. Spec.

C-76035-08.1-A

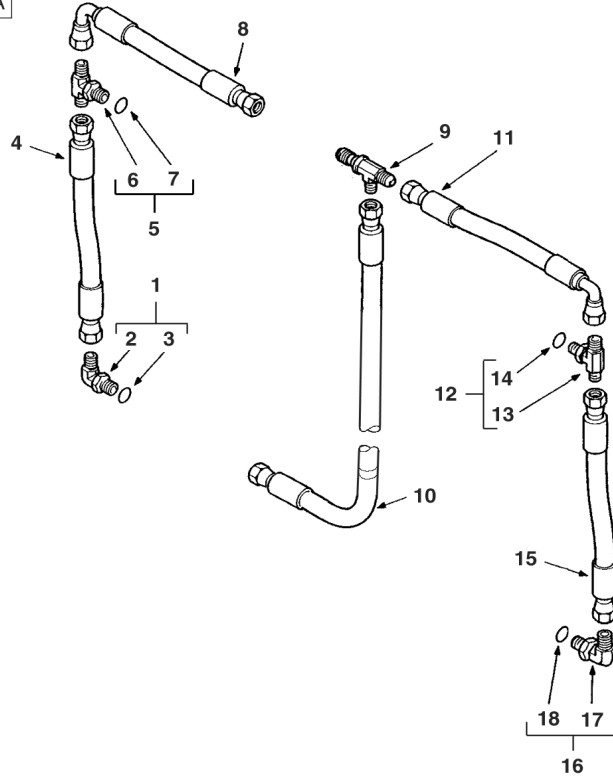

1	358761X91			1	Elbow, 90°	Coude à 90°	Codo, 90°
2		1	➡ Ref. 1	1	Elbow	Coude	Codo
3	831496M1	1		1	O-Ring	Joint torique	Junta de tipo O
4	3521882M94			1	Hose Assy	Ensemble de flexible	Flexible, Conj.
5	358827X91			1	Tee	Raccord en T	Te
6		5	➡ Ref. 5	1	Tee	Raccord en T	Te
7	831496M1	5		1	O-Ring	Joint torique	Junta de tipo O
8	3521878M93			1	Hose Assy	Ensemble de flexible	Flexible, Conj.
9	356558X1			1	Tee	Raccord en T	Te
10	6110207M91	Clamp		1	Hose Assy	Ensemble de flexible	Flexible, Conj.
11	3521878M93			1	Hose Assy	Ensemble de flexible	Flexible, Conj.
12	358827X91			1	Tee	Raccord en T	Te
13		12	➡ Ref. 12	1	Tee	Raccord en T	Te
14	831496M1	12		1	O-Ring	Joint torique	Junta de tipo O
15	3521882M94			1	Hose Assy	Ensemble de flexible	Flexible, Conj.
16	358761X91			1	Elbow, 90°	Coude à 90°	Codo, 90°
17		16	➡ Ref. 16	1	Elbow	Coude	Codo
18	831496M1	16		1	O-Ring	Joint torique	Junta de tipo O



820
 TX760B

805 806 807 808 833 834

76035C08.1

6199042M3

1

Jan-06

Digger Hydraulics
Circuit Hydraulique Défonceuse
Circuito hidráulico equipo retro

Sideshift
Montage de Pelle Latéral
Excavadora de montaje horizontal

Attachment
Attache
Equipo

C-76035-09.1-A

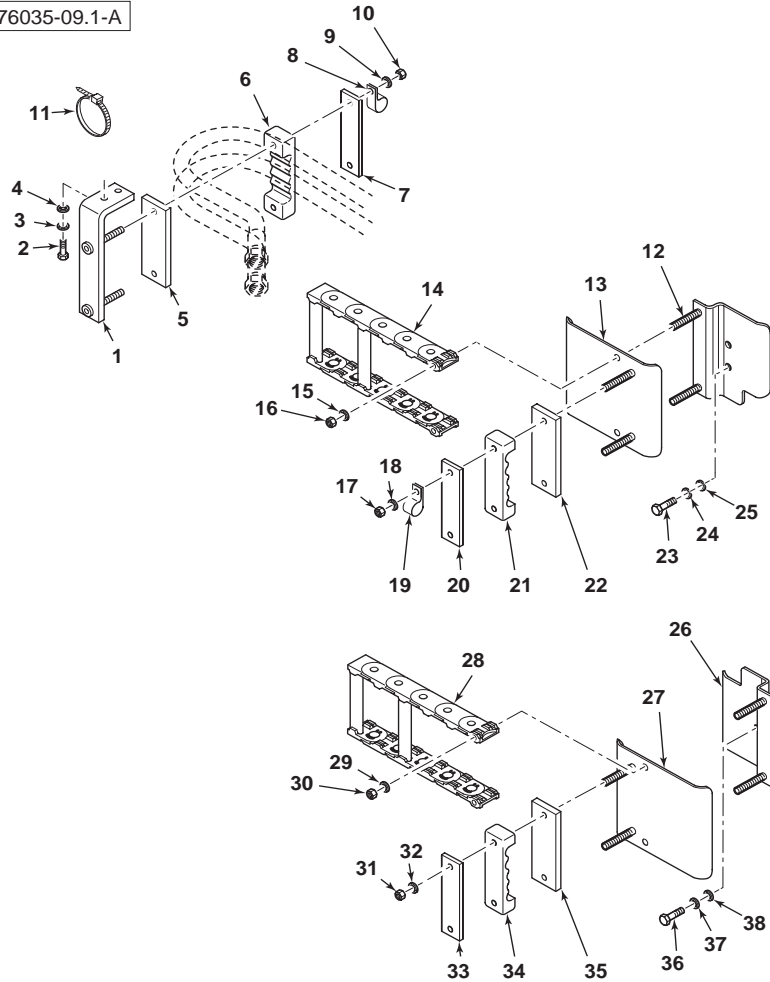

1	6107934M91		2	Bracket, Clamp	Bride de fixation	Brida de fijación
2	339761X1	M8 x 25	4	Screw	Vis	Tornillo
3	390972X1	M8	4	Washer	Rondelle	Arandela
4	339374X1	M8	4	Washer, Lock	Rondelle de blocage	Arandela de freno
5	6102197M1		2	Pad, Rubber	Plaque de caoutchouc	Placa, Caucho
6	6101216M1	◀	1	Clamp	Collier de serrage	Argolla de cierre
6	6101859M1	▶	1	Clamp	Collier de serrage	Argolla de cierre
7	6101215M1		2	Plate	Plaque	Placa
8	515-22159		1	Clip, Mounting	Collier de fixation	Argolla de fijación
9	390972X1	M8	4	Washer	Rondelle	Arandela
10	394367X1	M8	4	Nut, Lock	Écrou de blocage	Tuerca de retención
11	1862425M1		1	Tie, Cable	Attache câble	Enlace de Cable
12	6102307M91	▶	1	Bracket, Clamp	Bride de fixation	Brida de fijación
13	6101424M91		1	Plate Assy	Ensemble de plaque	Placa, Conj.
14	6102199M92		1	Chain	Chaîne	Cadena
15	390971X1	M6	2	Washer	Rondelle	Arandela
16	1441500X1	M6	2	Nut, Lock	Écrou de blocage	Tuerca de retención
17	394367X1	M8	2	Nut, Lock	Écrou de blocage	Tuerca de retención
18	390972X1	M8	2	Washer	Rondelle	Arandela
19	515-22159		1	Clip, Mounting	Collier de fixation	Argolla de fijación
20	6101215M1		1	Plate	Plaque	Placa
21	6101859M1		1	Clamp	Collier de serrage	Argolla de cierre
22	6102197M1		1	Pad, Rubber	Plaque de caoutchouc	Placa, Caucho
23	3009492X1	M10 x 25	2	Screw	Vis	Tornillo
24	339376X1	M10	2	Washer, Lock	Rondelle de blocage	Arandela de freno
25	390734X1	M10	2	Washer	Rondelle	Arandela
26	6102308M91	◀	1	Bracket, Clamp	Bride de fixation	Brida de fijación
27	6101424M91		1	Plate Assy	Ensemble de plaque	Placa, Conj.
28	6102199M92		1	Chain	Chaîne	Cadena
29	390971X1	M6	2	Washer	Rondelle	Arandela
30	1441500X1	M6	2	Nut, Lock	Écrou de blocage	Tuerca de retención
31	394367X1	M8	2	Nut, Lock	Écrou de blocage	Tuerca de retención
32	390972X1	M8	2	Washer	Rondelle	Arandela
33	6101215M1		1	Plate	Plaque	Placa
34	6101216M1	◀	1	Clamp	Collier de serrage	Argolla de cierre
35	6102197M1		1	Pad, Rubber	Plaque de caoutchouc	Placa, Caucho
36	3009492X1	M10 x 25	2	Screw	Vis	Tornillo
37	339376X1	M10	2	Washer, Lock	Rondelle de blocage	Arandela de freno
38	390734X1	M10	2	Washer	Rondelle	Arandela



820
TX760B

805 806 807 808 833 834

76035C09.1

6199042M3

1

Jan-06

Digger Hydraulics
Circuit Hydraulique Défonceuse
Circuito hidráulico equipo retro

Sideshift
Montage de Pelle Latéral
Excavadora de montaje horizontal

Bucket
 Godet
 Cuchara

High Spec.
 High Spec.
 High Spec.

C-76036-01.1-A

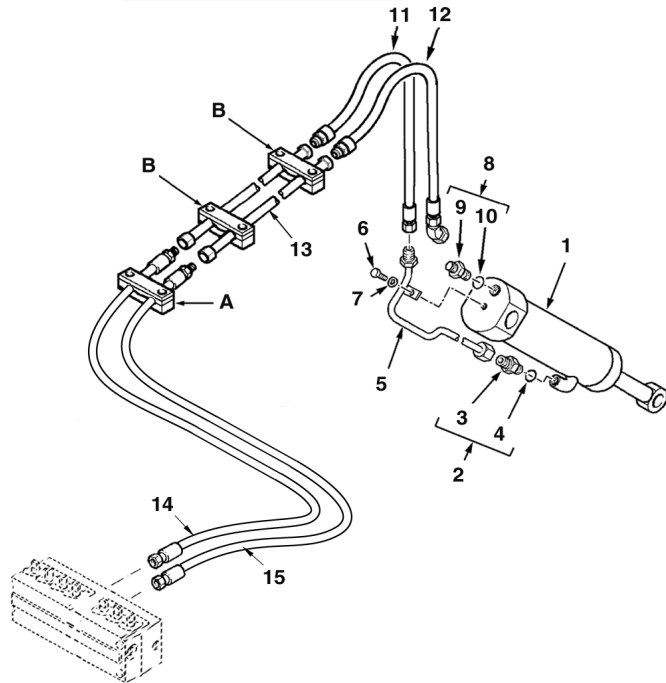
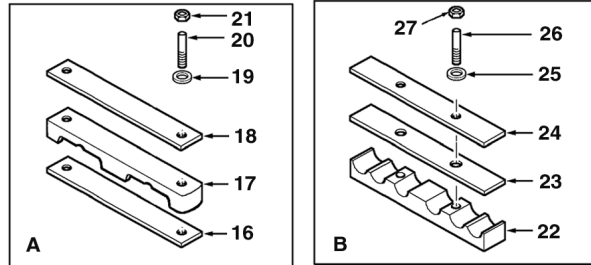

1	5000126M91	76036C02.1 1	1	Cylinder Assy	Ensemble de vérin	Gato, Conj.
2	835013M91		1	Connector Assy	Ensemble connexion	Conexión, Conj.
3		2 Ref. 2	1	Union	Union	Unión
4	835024M1	2	1	O-Ring	Joint torique	Junta de tipo O
5	6101540M91		1	Tube Assy	Tuyauterie	Conjunto de tubería
6	339123X1	M8 x 20	1	Bolt	Boulon	Perno
7	385361X1	M8	1	Washer	Rondelle	Arandela
8	835013M91		1	Connector Assy	Ensemble connexion	Conexión, Conj.
9		8 Ref. 8	1	Union	Union	Unión
10	835024M1	8	1	O-Ring	Joint torique	Junta de tipo O
11	6102309M91	Brown	1	Hose Assy	Ensemble de flexible	Flexible, Conj.
12	6107024M91	White	1	Hose Assy	Ensemble de flexible	Flexible, Conj.
13	6101771M91		2	Tube Assy	Tuyauterie	Conjunto de tubería
14	6108762M91	Brown	1	Hose Assy	Ensemble de flexible	Flexible, Conj.
15	6108763M91	White	1	Hose Assy	Ensemble de flexible	Flexible, Conj.
16	6102128M1		1	Pad	Plaque antidérapante	Cinta antideslizante
17	6102122M1		1	Bracket, Clamp	Bride de fixation	Brida de fijación
18	6102130M1		1	Plate	Plaque	Placa
19	390972X1	M8	2	Washer	Rondelle	Arandela
20	3516075M1	M8 x 65	2	Stud	Goujon	Espárrago
21	394367X1	M8	2	Nut, Lock	Écrou de blocage	Tuerca de retención
22	6102126M1		2	Bracket, Clamp	Bride de fixation	Brida de fijación
23	6102145M1		2	Pad	Plaque antidérapante	Cinta antideslizante
24	6102124M1		2	Plate	Plaque	Placa
25	390972X1	M8	4	Washer	Rondelle	Arandela
26	6108049M1		4	Stud	Goujon	Espárrago
27	394367X1	M8	4	Nut, Lock	Écrou de blocage	Tuerca de retención



860 880 970 980
 TX860B

817 825 845 855 921 931

76036C01.1

6199042M3

1

Jan-06

Digger Hydraulics
Circuit Hydraulique Défonceuse
Circuito hidráulico equipo retro

Sideshift
Montage de Pelle Latéral
Excavadora de montaje horizontal

Bucket Cylinder
Vérin de Godet
Gato de cuchara

High Spec.
 High Spec.
 High Spec.

C-76036-02.1-A

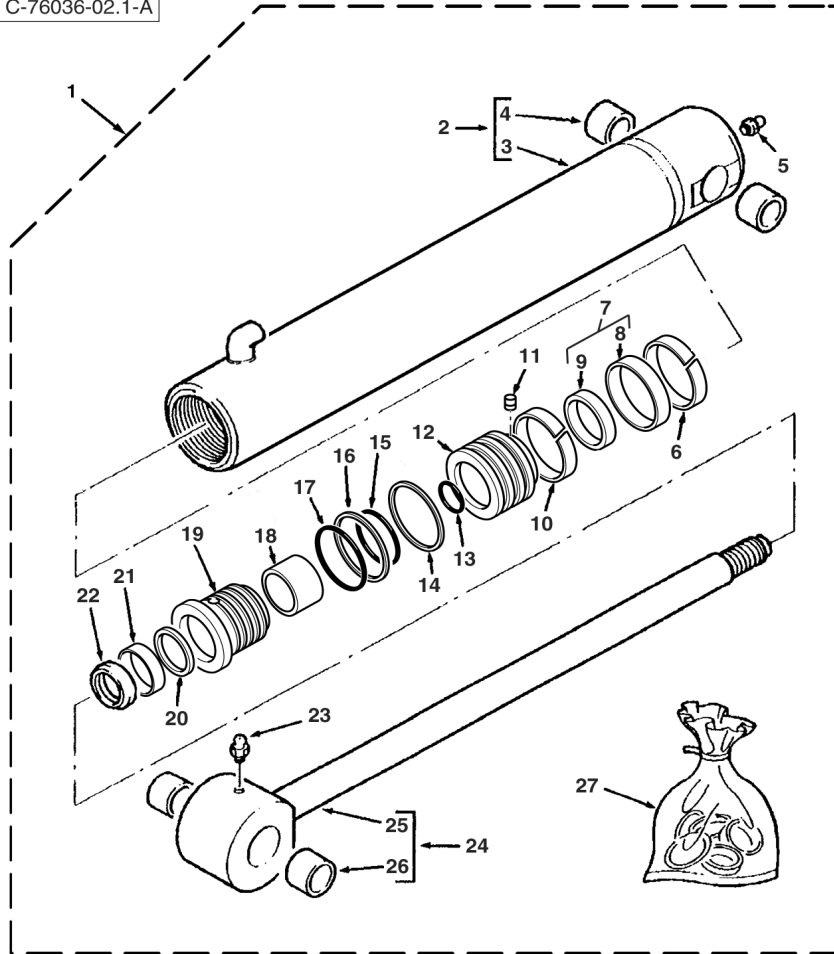

1	5000126M91		76036C01.1 1	1	Cylinder Assy	Ensemble de vérin	Gato, Conj.
2	5004008M91	1		1	Cylinder	Cylindre	Cilindro
3		3	Ref. 2	1	Tube, Cylinder	Cylindre de vérin	Cilindro de gato
4		3 (C)		1	Bushing	Bague	Anillo
5	339608X1	1		1	Fitting, Grease	Graisser	Engrasador
6	3485892M1	1 (A)		1	Ring, Sealing	Bague d'étanchéité	Anillo, Estanqueidad
7	3485245M91	1 (A)		1	Seal Assy	Ensemble de joint	Junta, Conj.
8		7	Ref. 7	1	Seal	Joint	Junta
9		7	Ref. 7	1	Ring	Anneau	Aro
10	3485892M1	1 (A)		1	Ring, Sealing	Bague d'étanchéité	Anillo, Estanqueidad
11	3402928M1	1		1	Screw	Vis	Tornillo
12	3623372M1	1		1	Piston	Piston	Pistón
13	359186X1	1 (A)		1	O-Ring	Joint torique	Junta de tipo O
14	3623061M1	1		1	Ring, Piston	Segment de piston	Segmento de pistón
15	359193X1	1 (A)		1	O-Ring	Joint torique	Junta de tipo O
16	1606735M1	1 (A)		1	Ring, Backup	Contre-joint	ContraJunta
17	3487207M1	1 (A)		1	O-Ring	Joint torique	Junta de tipo O
18	3484615M1	1 (A)		1	Ring	Anneau	Aro
19	3623371M1	1		1	Bearing	Coussinet	Cojinete
20	3484055M1	1 (A)		1	Ring	Anneau	Aro
21	3485185M1	1 (A)		1	Seal	Joint	Junta
22	3487015M1	1 (A)		1	Ring	Anneau	Aro
23	339608X1	1		1	Fitting, Grease	Graisser	Engrasador
24	5004012M91	1		1	Rod, Piston	Tige de vérin	Vástago cilindro
25		24	Ref. 24	1	Rod, Piston	Tige de vérin	Vástago cilindro
26		24 (C)		1	Bushing	Bague	Anillo
27	3623373M91		(B)	1	Kit, Seal	Pochette de joints	Juego de juntas

A Contains items marked (A)
 Comprend les pièces marquées (A)
 Incluye las piezas marcadas (A)
 C Part number to be advised
 Référence pièce à demander
 Indicar número de pieza

B Included in kit marked (B)
 Inclus dans jeu marqué (B)
 Incluido en juego marcado (B)



860 880 970 980
 TX860B

817 825 845 855 921 931

76036C02.1

6199042M3

1

Jan-06

Digger Hydraulics
Circuit Hydraulique Défonceuse
Circuito hidráulico equipo retro

Sideshift
Montage de Pelle Latéral
Excavadora de montaje horizontal

Standard Dipper
Balancier Standard
Balancín estándar

High Spec.
 High Spec.
 High Spec.

C-76036-03.1-A

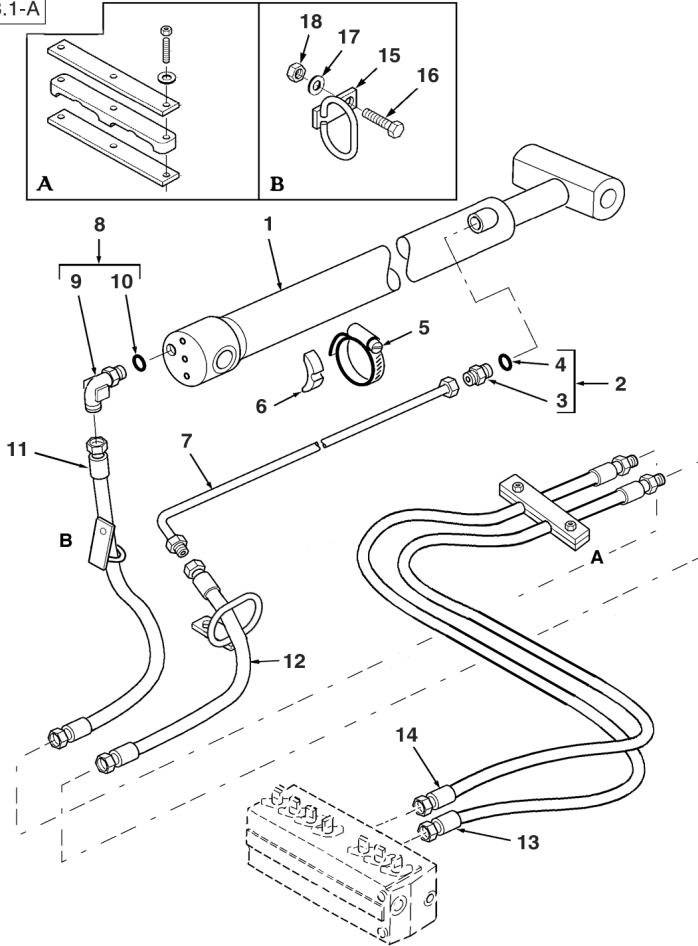

1	5000124M91	76036C04.1 1	1	Cylinder Assy	Ensemble de vérin	Gato, Conj.
2	835013M91		1	Connector Assy	Ensemble connexion	Conexión, Conj.
3		2 Ref. 2	1	Union	Union	Unión
4	835024M1	2	1	O-Ring	Joint torique	Junta de tipo O
5	3517733M1		1	Clamp	Collier de serrage	Argolla de cierre
6	L79937		1	Spacer	Entretoise	Travesa
7		(A,B)	1	Tube Assy	Tuyauterie	Conjunto de tubería
8		(A,B)	1	Elbow	Coude	Codo
9		8 (A,B) Ref. 8	1	Elbow	Coude	Codo
10		8 (A,B)	1	O-Ring	Joint torique	Junta de tipo O
11	6101738M91	Yellow	1	Hose Assy	Ensemble de flexible	Flexible, Conj.
12	6101737M91	Red	1	Hose Assy	Ensemble de flexible	Flexible, Conj.
13	6108767M91	Yellow	1	Hose Assy	Ensemble de flexible	Flexible, Conj.
14	6108766M91	Red	1	Hose Assy	Ensemble de flexible	Flexible, Conj.
15	6101491M92		2	Support Assy	Ensemble de support	Apoyadero, Conj.
16	339761X1	M8 x 25	2	Screw	Vis	Tornillo
17	390972X1	M8	2	Washer	Rondelle	Arandela
18	394367X1	M8	2	Nut, Lock	Écrou de blocage	Tuerca de retención

A Without Hose Burst
 Sans éclatement de tuyau
 Sin rotura de tubo flexible

B See hose burst section
 Voir la section éclatement de tuyau
 Ver la sección de rotura de tubo flexible



860 880 970 980
 TX860B

817 825 845 855 921 931

76036C03.1

6199042M3

1

Jan-06

Digger Hydraulics
Circuit Hydraulique Défonceuse
Circuito hidráulico equipo retro

Sideshift
Montage de Pelle Latéral
Excavadora de montaje horizontal

Dipper Cylinder
Vérin de Balancier
Gato de balancín

High Spec.
 High Spec.
 High Spec.

C-76036-04.1-A

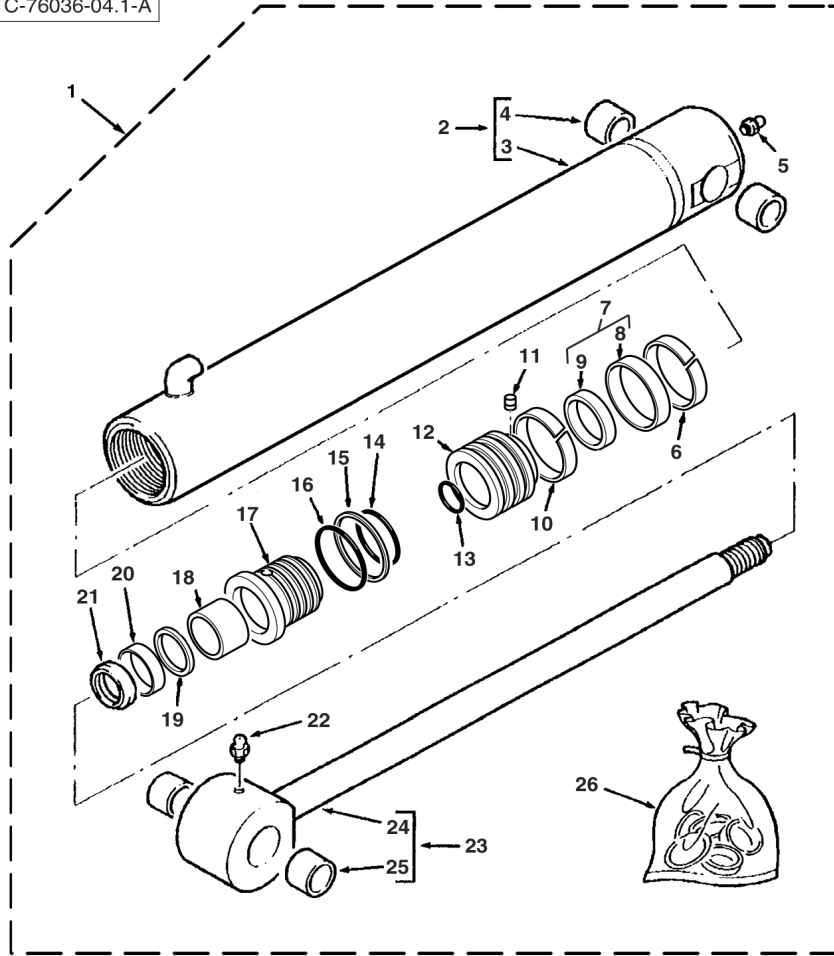

1	5000124M91		76036C03.1 1	1	Cylinder Assy	Ensemble de vérin	Gato, Conj.
2	5003982M91	1		1	Cylinder	Cylindre	Cilindro
3		2	Ref. 2	1	Tube, Cylinder	Cylindre de vérin	Cilindro de gato
4	3484843M1	2		1	Bush	Bague	Casquillo
5	339608X1	1		1	Fitting, Grease	Graisneur	Engrasador
6	3485891M1	1 (A)		1	Ring	Anneau	Aro
7	3485247M91	1 (A)		1	Seal Assy	Ensemble de joint	Junta, Conj.
8		7	Ref. 7	1	Seal	Joint	Junta
9		7	Ref. 7	1	Ring	Anneau	Aro
10	3485891M1	1 (A)		1	Ring	Anneau	Aro
11	3402928M1	1		1	Screw	Vis	Tornillo
12	5003989M1	1		1	Piston	Piston	Pistón
13	3007182X1	1 (A)		1	O-Ring	Joint torique	Junta de tipo O
14	359196X1	1 (A)		1	O-Ring	Joint torique	Junta de tipo O
15	378545X1	1 (A)		1	Ring	Anneau	Aro
16	3487908M1	1 (A)		1	O-Ring	Joint torique	Junta de tipo O
17	5003988M1	1		1	Bearing	Coussinet	Cojinete
18	3623193M1	1 (A)		1	Ring	Anneau	Aro
19	3443388M1	1 (A)		1	Ring	Anneau	Aro
20	3443472M1	1 (A)		1	Seal	Joint	Junta
21	3403385M1	1 (A)		1	Ring, Wiper	Joint de racler	Junta raspador
22	339608X1	1		1	Fitting, Grease	Graisneur	Engrasador
23	5003985M91	1		1	Rod, Piston	Tige de vérin	Vástago cilindro
24		23	Ref. 23	1	Rod, Piston	Tige de vérin	Vástago cilindro
25	3484843M1	23		1	Bush	Bague	Casquillo
26	5004401M91		(B)	1	Kit, Seal	Pochette de joints	Juego de juntas

A Included in kit marked (B)
 Inclus dans jeu marqué (B)
 Incluido en juego marcado (B)

B Contains items marked (A)
 Comprend les pièces marquées (A)
 Incluye las piezas marcadas (A)



860 880 970 980
 TX860B

817 825 845 855 921 931

76036C04.1

6199042M3

1

Jan-06

Digger Hydraulics
Circuit Hydraulique Défonceuse
Circuito hidráulico equipo retro

Sideshift
Montage de Pelle Latéral
Excavadora de montaje horizontal

Boom
 Flèche
 Pluma

High Spec.
 High Spec.
 High Spec.

C-76036-05.1-A

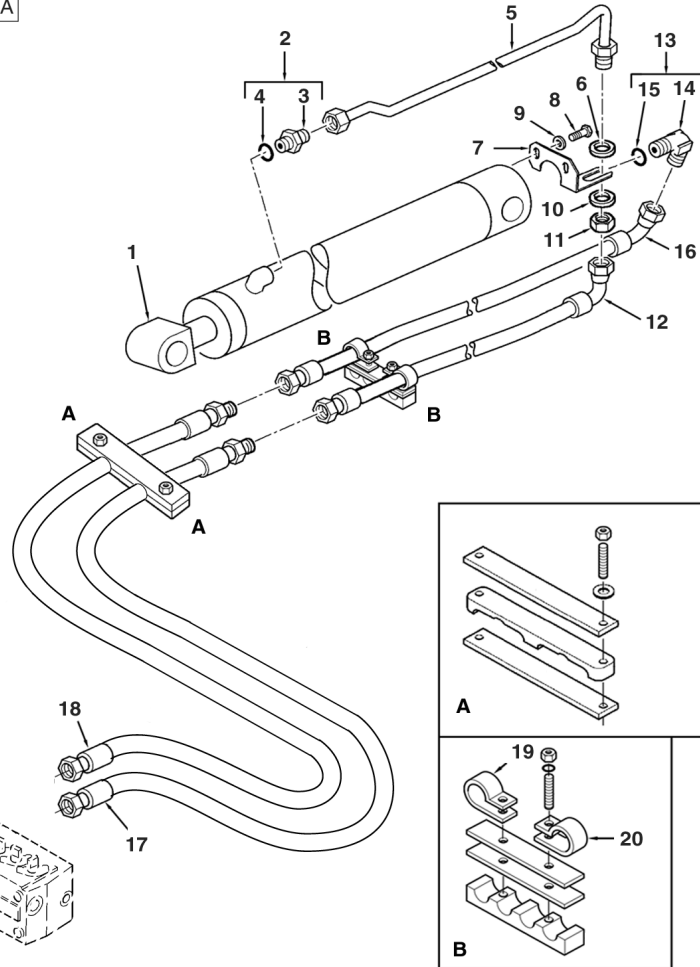

1	5000122M91	76036C06.1 1 4.5m Boom	1	Cylinder Assy	Ensemble de vérin	Gato, Conj.
2	835013M91		1	Connector Assy	Ensemble connexion	Conexión, Conj.
3		Ref. 2	1	Union	Union	Unión
4	835024M1		1	O-Ring	Joint torique	Junta de tipo O
5		(A,B)	1	Tube Assy	Tuyauterie	Conjunto de tubería
6		(A,B)	1	Washer	Rondelle	Arandela
7		(A,B)	1	Bracket	Patte de fixation	Pata de fijación
8	339228X1	M8 x 12	2	Screw	Vis	Tornillo
9	339374X1	M8	2	Washer, Lock	Rondelle de blocage	Arandela de freno
10		(A,B)	1	Washer	Rondelle	Arandela
11		(A,B)	1	Nut	Écrou	Tuerca
12		(A,B)Orange	1	Hose Assy	Ensemble de flexible	Flexible, Conj.
13		(A,B)	1	Elbow	Coude	Codo
14		Ref. 13	1	Elbow	Coude	Codo
15		Ref. 13	1	O-Ring	Joint torique	Junta de tipo O
16	6101736M92	Blue	1	Hose Assy	Ensemble de flexible	Flexible, Conj.
17	6108761M91	Orange	1	Hose Assy	Ensemble de flexible	Flexible, Conj.
18	6108760M91	Blue	1	Hose Assy	Ensemble de flexible	Flexible, Conj.
19	515-23270		1	Clip	Clip	Clip
20	515-23206		1	Clip	Clip	Clip

A Without Hose Burst
 Sans éclatement de tuyau
 Sin rotura de tubo flexible

B See hose burst section
 Voir la section éclatement de tuyau
 Ver la sección de rotura de tubo flexible



860 880 970 980
 TX860B

817 825 845 855 921 931

76036C05.1

6199042M3

1

Jan-06

Digger Hydraulics
Circuit Hydraulique Défonceuse
Circuito hidráulico equipo retro

Sideshift
Montage de Pelle Latéral
Excavadora de montaje horizontal

Boom Cylinder
Vérin de Flèche
Gato de pluma

High Spec.
 High Spec.
 High Spec.

C-76036-06.1-A

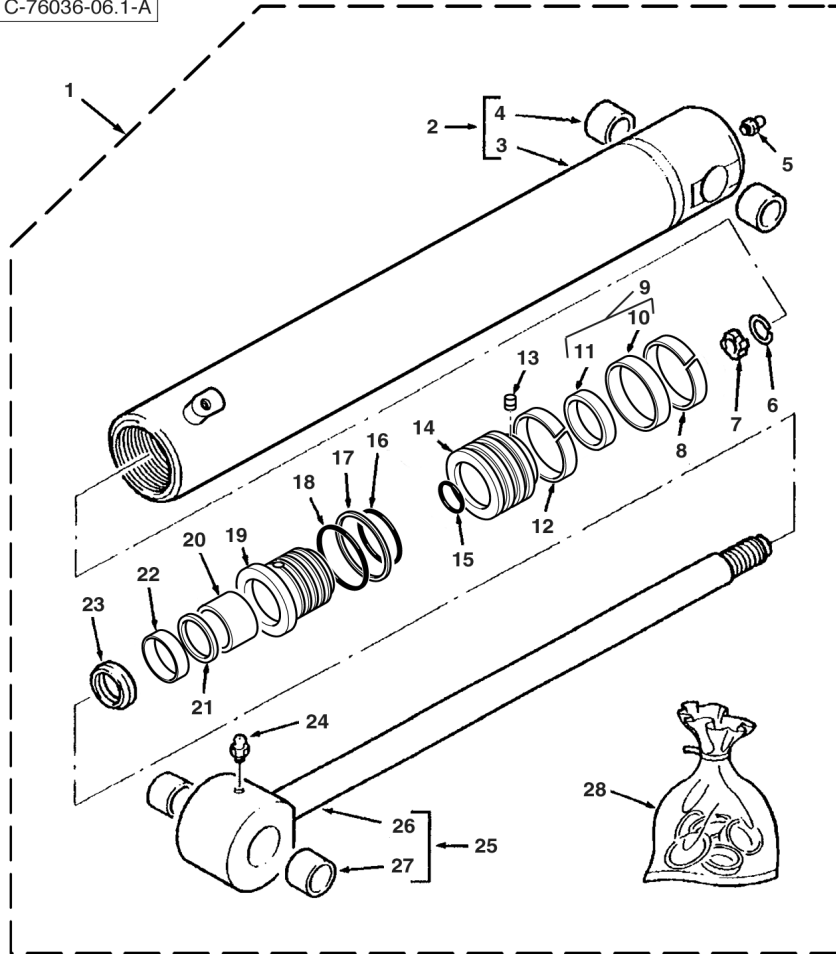

1	5000122M91	76036C05.1 1 4.5m Boom	1	Cylinder Assy	Ensemble de vérin	Gato, Conj.
2	5003912M91	1	1	Cylinder	Cylindre	Cilindro
3		2	1	Tube, Cylinder	Cylindre de vérin	Cilindro de gato
4		2 (C)	2	Bushing	Bague	Anillo
5	339608X1	1	1	Fitting, Grease	Graisser	Engrasador
6	1609899M1	1	1	Ring, Snap	Anneau d'arrêt	Anillo de resorte
7	1609328M1	1	1	Ring	Anneau	Aro
8	3403852M1	1 (A)	2	Ring	Anneau	Aro
9	3485213M91	1 (A)	1	Seal Assy	Ensemble de joint	Junta, Conj.
10		9	1	Seal	Joint	Junta
11		9	1	Seal	Joint	Junta
13	3402928M1	1	1	Screw	Vis	Tornillo
14	3484189M1	1	1	Piston	Piston	Pistón
15	3007182X1	1 (A)	1	O-Ring	Joint torique	Junta de tipo O
16	359203X1	1 (A)	1	O-Ring	Joint torique	Junta de tipo O
17	367120X1	1 (A)	1	Ring	Anneau	Aro
18	3487909M1	1 (A)	1	O-Ring	Joint torique	Junta de tipo O
19	3623202M1	1	1	Bearing	Coussinet	Cojinete
20	3623193M1	1 (A)	1	Ring	Anneau	Aro
21	3443388M1	1 (A)	1	Ring	Anneau	Aro
22	3443472M1	1 (A)	1	Seal	Joint	Junta
23	3403385M1	1 (A)	1	Ring, Wiper	Joint de racleur	Junta raspador
24	339608X1	1	1	Fitting, Grease	Graisser	Engrasador
25	3441629M91	1	1	Rod, Piston	Tige de vérin	Vástago cilindro
26		25	1	Rod, Piston	Tige de vérin	Vástago cilindro
27	3484843M1	25	1	Bush	Bague	Casquillo
28	3623589M91	(B)	1	Kit, Seal	Pochette de joints	Juego de juntas

A Included in kit marked (B)
 Inclus dans jeu marqué (B)
 Incluido en juego marcado (B)
 C Part number to be advised
 Référence pièce à demander
 Indicar número de pieza

B Contains items marked (A)
 Comprend les pièces marquées (A)
 Incluye las piezas marcadas (A)



860 880 970 980
 TX860B

817 825 845 855 921 931

76036C06.1

6199042M3

1

Jan-06

Digger Hydraulics
Circuit Hydraulique Défonceuse
Circuito hidráulico equipo retro

Sideshift
Montage de Pelle Latéral
Excavadora de montaje horizontal

Swing Components
Organes de Rotation
Componentes de rotación

High Spec.
High Spec.
High Spec.

C-76036-07.1-A

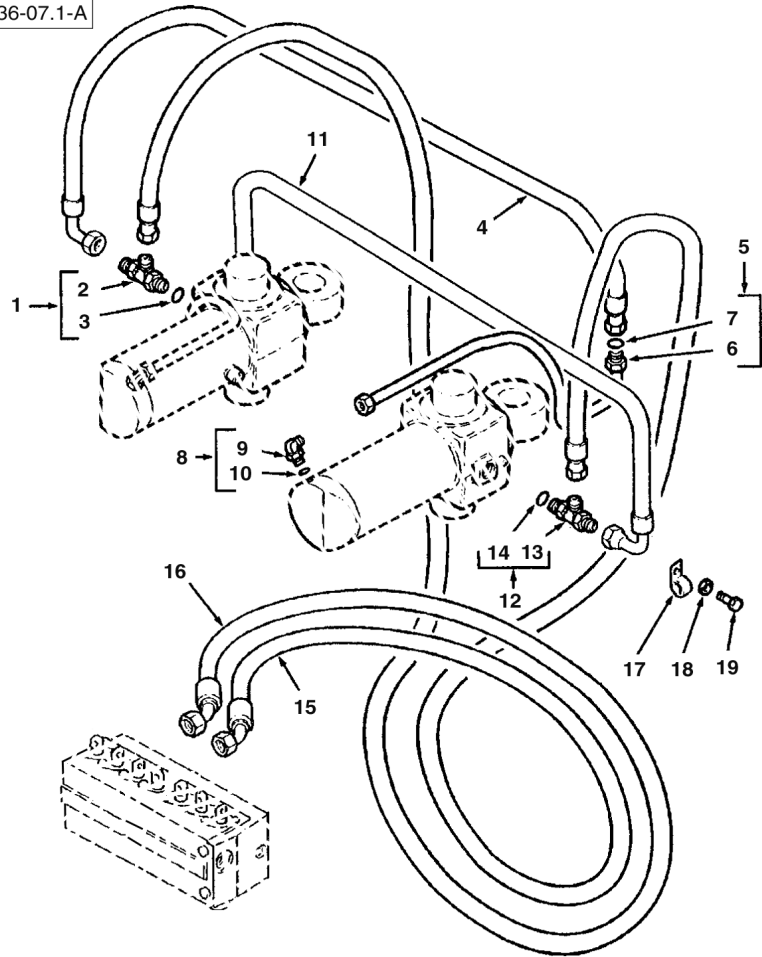

1	358728X91		1	Tee	Raccord en T	Te	
2		1	▶ Ref. 1	1	Tee	Raccord en T	Te
3	831497M1	1		1	O-Ring	Joint torique	Junta de tipo O
4	6100716M91	840 mm		1	Hose Assy	Ensemble de flexible	Flexible, Conj.
5	6100587M91	◀		1	Tube Assy	Tuyauterie	Conjunto de tubería
5	6100589M91	▶		1	Tube Assy	Tuyauterie	Conjunto de tubería
6		5	▶ Ref. 5	1	Tube	Tube	Tubo
7	394923X1	5		1	O-Ring	Joint torique	Junta de tipo O
8	357197X91			2	Elbow, 90°	Coude à 90°	Codo, 90°
9		8	▶ Ref. 8	1	Elbow	Coude	Codo
10	831452M1	8		1	O-Ring	Joint torique	Junta de tipo O
11	6100716M91	840 mm		1	Hose Assy	Ensemble de flexible	Flexible, Conj.
12	358728X91			1	Tee	Raccord en T	Te
13		12	▶ Ref. 12	1	Tee	Raccord en T	Te
14	831497M1	12		1	O-Ring	Joint torique	Junta de tipo O
15	6107456M91	◀ 1745 mm		1	Hose Assy	Ensemble de flexible	Flexible, Conj.
16	6107455M91	▶ 1745 mm		1	Hose Assy	Ensemble de flexible	Flexible, Conj.
17	3517114M2			2	Clip, Mounting	Collier de fixation	Argolla de fijación
18	385361X1	M8		2	Washer	Rondelle	Arandela
19	339228X1	M8 x 12		2	Screw	Vis	Tornillo



860 880 970 980
 TX860B

817 825 845 855 921 931

76036C07.1

6199042M3

1

Jan-06

Digger Hydraulics
 Circuit Hydraulique Défonceuse
 Circuito hidráulico equipo retro

Sideshift
 Montage de Pelle Latéral
 Excavadora de montaje horizontal

Clamp
 Collier
 Abrazadera

High Spec.
 High Spec.
 High Spec.

C-76036-08.1-A

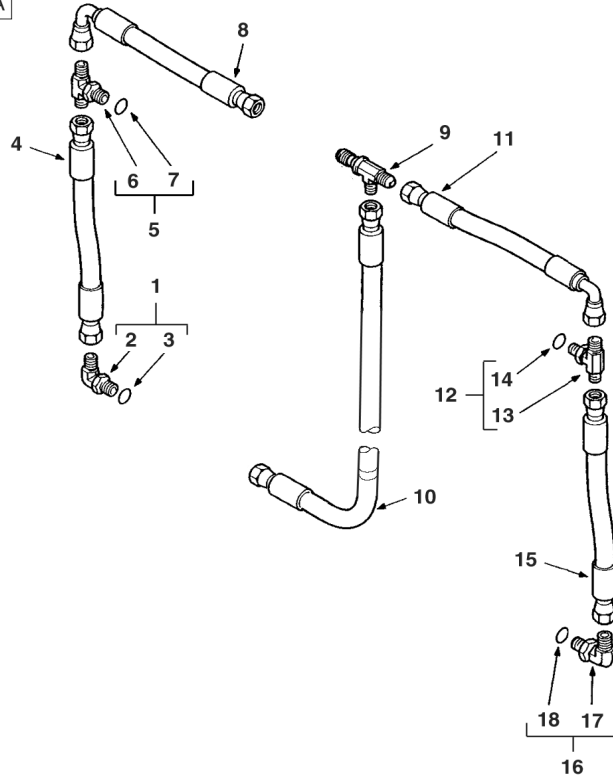

1	358761X91			1	Elbow, 90°	Coude à 90°	Codo, 90°
2		1	▶ Ref. 1	1	Elbow	Coude	Codo
3	831496M1	1		1	O-Ring	Joint torique	Junta de tipo O
4	3521882M94			1	Hose Assy	Ensemble de flexible	Flexible, Conj.
5	358827X91			1	Tee	Raccord en T	Te
6		5	▶ Ref. 5	1	Tee	Raccord en T	Te
7	831496M1	5		1	O-Ring	Joint torique	Junta de tipo O
8	3521878M93			1	Hose Assy	Ensemble de flexible	Flexible, Conj.
9	356558X1			1	Tee	Raccord en T	Te
10	6110207M91	Clamp		1	Hose Assy	Ensemble de flexible	Flexible, Conj.
11	3521878M93			1	Hose Assy	Ensemble de flexible	Flexible, Conj.
12	358827X91			1	Tee	Raccord en T	Te
13		12	▶ Ref. 12	1	Tee	Raccord en T	Te
14	831496M1	12		1	O-Ring	Joint torique	Junta de tipo O
15	3521882M94			1	Hose Assy	Ensemble de flexible	Flexible, Conj.
16	358761X91			1	Elbow, 90°	Coude à 90°	Codo, 90°
17		16	▶ Ref. 16	1	Elbow	Coude	Codo
18	831496M1	16		1	O-Ring	Joint torique	Junta de tipo O



860 880 970 980
 TX860B

817 825 845 855 921 931

76036C08.1

6199042M3

1

Jan-06

Digger Hydraulics
Circuit Hydraulique Défonceuse
Circuito hidráulico equipo retro

Sideshift
Montage de Pelle Latéral
Excavadora de montaje horizontal

Attachment
Attache
Equipo

C-76036-09.1-A

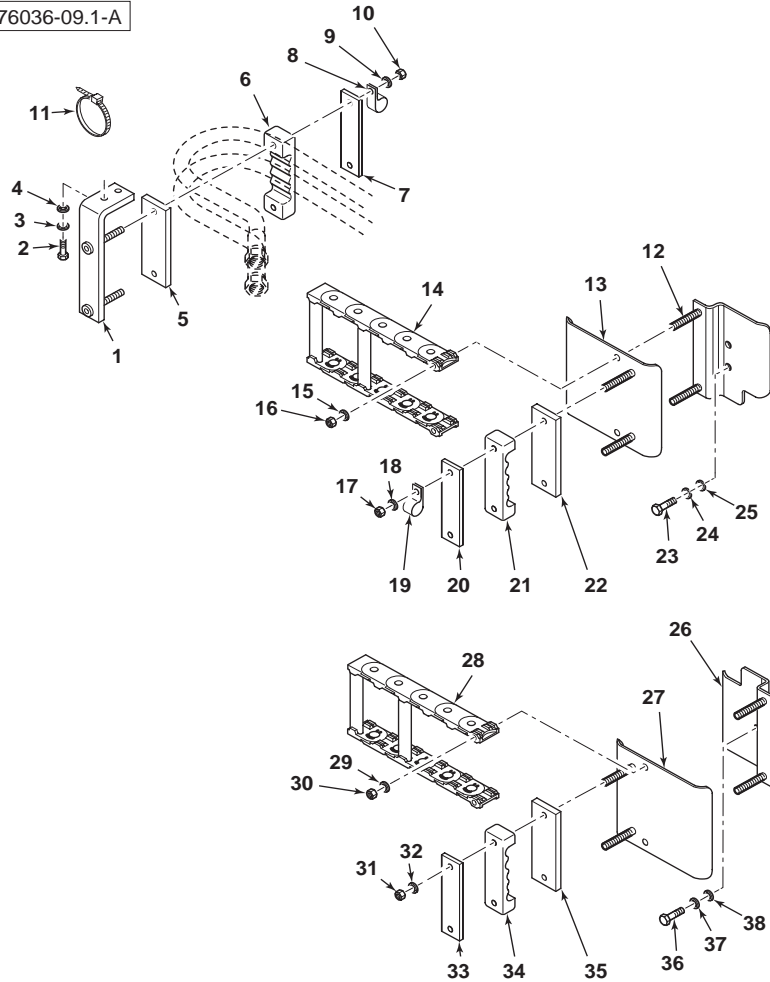

1	6107934M91		2	Bracket, Clamp	Bride de fixation	Brida de fijación
2	339761X1	M8 x 25	4	Screw	Vis	Tornillo
3	390972X1	M8	4	Washer	Rondelle	Arandela
4	339374X1	M8	4	Washer, Lock	Rondelle de blocage	Arandela de freno
5	6102197M1		2	Pad, Rubber	Plaque de caoutchouc	Placa, Caucho
6	6101216M1	◀	1	Clamp	Collier de serrage	Argolla de cierre
6	6101859M1	▶	1	Clamp	Collier de serrage	Argolla de cierre
7	6101215M1		2	Plate	Plaque	Placa
8	515-22159		1	Clip, Mounting	Collier de fixation	Argolla de fijación
9	390972X1	M8	4	Washer	Rondelle	Arandela
10	394367X1	M8	4	Nut, Lock	Écrou de blocage	Tuerca de retención
11	1862425M1		1	Tie, Cable	Attache câble	Enlace de Cable
12	6102307M91	▶	1	Bracket, Clamp	Bride de fixation	Brida de fijación
13	6101424M91		1	Plate Assy	Ensemble de plaque	Placa, Conj.
14	6102199M92		1	Chain	Chaîne	Cadena
15	390971X1	M6	2	Washer	Rondelle	Arandela
16	1441500X1	M6	2	Nut, Lock	Écrou de blocage	Tuerca de retención
17	394367X1	M8	2	Nut, Lock	Écrou de blocage	Tuerca de retención
18	390972X1	M8	2	Washer	Rondelle	Arandela
19	515-22159		1	Clip, Mounting	Collier de fixation	Argolla de fijación
20	6101215M1		1	Plate	Plaque	Placa
21	6101859M1		1	Clamp	Collier de serrage	Argolla de cierre
22	6102197M1		1	Pad, Rubber	Plaque de caoutchouc	Placa, Caucho
23	3009492X1	M10 x 25	2	Screw	Vis	Tornillo
24	339376X1	M10	2	Washer, Lock	Rondelle de blocage	Arandela de freno
25	390734X1	M10	2	Washer	Rondelle	Arandela
26	6102308M91	◀	1	Bracket, Clamp	Bride de fixation	Brida de fijación
27	6101424M91		1	Plate Assy	Ensemble de plaque	Placa, Conj.
28	6102199M92		1	Chain	Chaîne	Cadena
29	390971X1	M6	2	Washer	Rondelle	Arandela
30	1441500X1	M6	2	Nut, Lock	Écrou de blocage	Tuerca de retención
31	394367X1	M8	2	Nut, Lock	Écrou de blocage	Tuerca de retención
32	390972X1	M8	2	Washer	Rondelle	Arandela
33	6101215M1		1	Plate	Plaque	Placa
34	6101216M1	◀	1	Clamp	Collier de serrage	Argolla de cierre
35	6102197M1		1	Pad, Rubber	Plaque de caoutchouc	Placa, Caucho
36	3009492X1	M10 x 25	2	Screw	Vis	Tornillo
37	339376X1	M10	2	Washer, Lock	Rondelle de blocage	Arandela de freno
38	390734X1	M10	2	Washer	Rondelle	Arandela



860 880 970 980
 TX860B

817 825 845 855 921 931

76036C09.1

6199042M3

1

Jan-06

Digger Hydraulics
Circuit Hydraulique Défonceuse
Circuito hidráulico equipo retro

Sideshift
Montage de Pelle Latéral
Excavadora de montaje horizontal

Bucket
 Godet
 Cuchara

High Spec.
 High Spec.
 High Spec.

C-76037-01.1-A

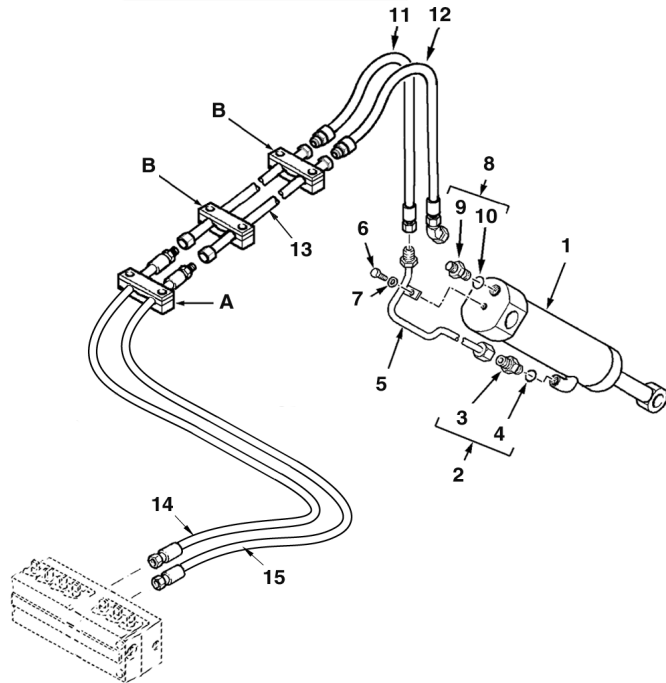
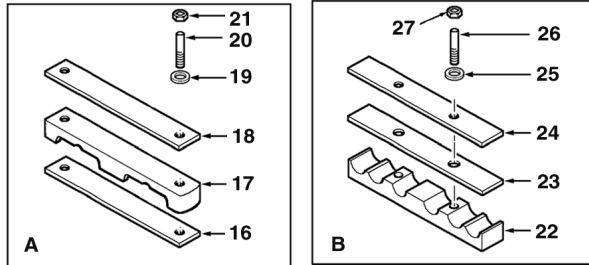

1	5000126M91	76037C02.1 1	1	Cylinder Assy	Ensemble de vérin	Gato, Conj.
2	835013M91		1	Connector Assy	Ensemble connexion	Conexión, Conj.
3		2 Ref. 2	1	Union	Union	Unión
4	835024M1	2	1	O-Ring	Joint torique	Junta de tipo O
5	6101540M91		1	Tube Assy	Tuyauterie	Conjunto de tubería
6	339123X1	M8 x 20	1	Bolt	Boulon	Perno
7	385361X1	M8	1	Washer	Rondelle	Arandela
8	835013M91		1	Connector Assy	Ensemble connexion	Conexión, Conj.
9		8 Ref. 8	1	Union	Union	Unión
10	835024M1	8	1	O-Ring	Joint torique	Junta de tipo O
11		(A)Brown	1	Hose Assy	Ensemble de flexible	Flexible, Conj.
12		(A)White	1	Hose Assy	Ensemble de flexible	Flexible, Conj.
13	6101771M91		2	Tube Assy	Tuyauterie	Conjunto de tubería
14	6108762M91	Brown	1	Hose Assy	Ensemble de flexible	Flexible, Conj.
15	6108763M91	White	1	Hose Assy	Ensemble de flexible	Flexible, Conj.
16	6102128M1		1	Pad	Plaque antidérapante	Cinta antideslizante
17	6102122M1		1	Bracket, Clamp	Bride de fixation	Brida de fijación
18	6102130M1		1	Plate	Plaque	Placa
19	390972X1	M8	2	Washer	Rondelle	Arandela
20	3516075M1	M8 x 65	2	Stud	Goujon	Espárrago
21	394367X1	M8	2	Nut, Lock	Écrou de blocage	Tuerca de retención
22	6102126M1		2	Bracket, Clamp	Bride de fixation	Brida de fijación
23	6102145M1		2	Pad	Plaque antidérapante	Cinta antideslizante
24	6102124M1		2	Plate	Plaque	Placa
25	390972X1	M8	4	Washer	Rondelle	Arandela
26	6108049M1		4	Stud	Goujon	Espárrago
27	394367X1	M8	4	Nut, Lock	Écrou de blocage	Tuerca de retención

A See extendahoe hydraulics section
 Voir la section circuit hydraulique extendahoe
 Ver la sección de la circuito hidráulico extendahoe



860 880 970 980
 TX860B

817 825 845 855 921 931

76037C01.1

6199042M3

1

Jan-06

Digger Hydraulics
Circuit Hydraulique Défonceuse
Circuito hidráulico equipo retro

Sideshift
Montage de Pelle Latéral
Excavadora de montaje horizontal

Bucket Cylinder
Vérin de Godet
Gato de cuchara

High Spec.
 High Spec.
 High Spec.

C-76037-02.1-A

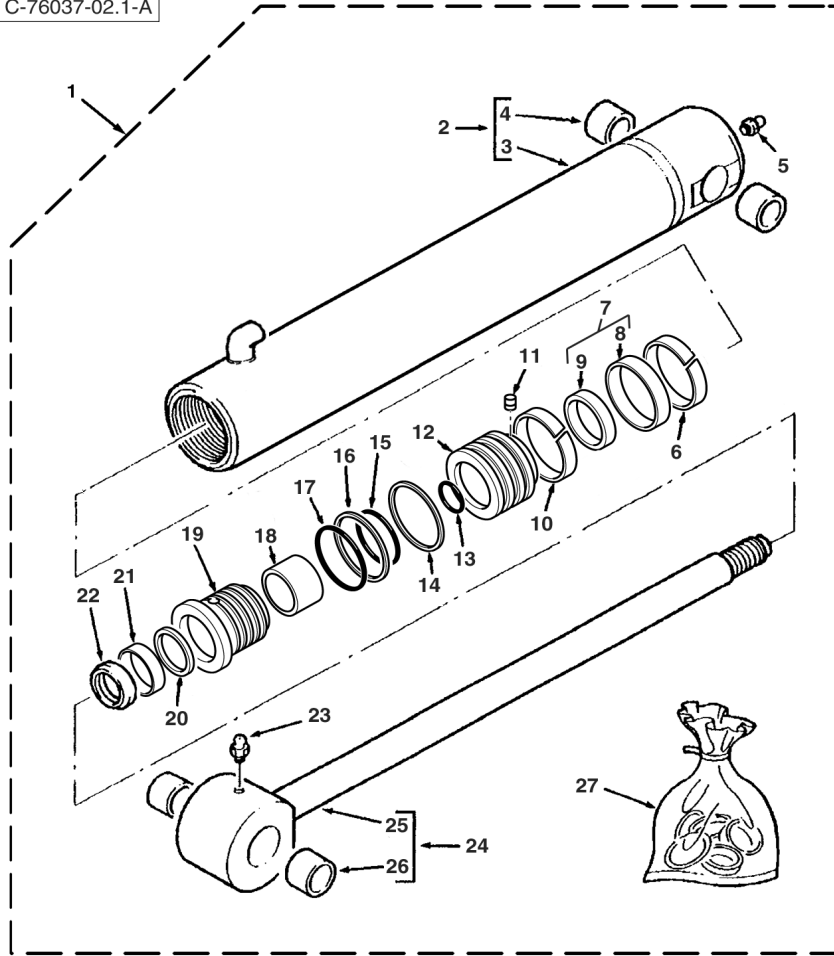

1	5000126M91		76037C01.1 1	1	Cylinder Assy	Ensemble de vérin	Gato, Conj.
2	5004008M91	1		1	Cylinder	Cylindre	Cilindro
3		3	Ref. 2	1	Tube, Cylinder	Cylindre de vérin	Cilindro de gato
4		3 (C)		1	Bushing	Bague	Anillo
5	339608X1	1		1	Fitting, Grease	Graisneur	Engrasador
6	3485892M1	1 (A)		1	Ring, Sealing	Bague d'étanchéité	Anillo, Estanqueidad
7	3485245M91	1 (A)		1	Seal Assy	Ensemble de joint	Junta, Conj.
8		7	Ref. 7	1	Seal	Joint	Junta
9		7	Ref. 7	1	Ring	Anneau	Aro
10	3485892M1	1 (A)		1	Ring, Sealing	Bague d'étanchéité	Anillo, Estanqueidad
11	3402928M1	1		1	Screw	Vis	Tornillo
12	3623372M1	1		1	Piston	Piston	Pistón
13	359186X1	1 (A)		1	O-Ring	Joint torique	Junta de tipo O
14	3623061M1	1		1	Ring, Piston	Segment de piston	Segmento de pistón
15	359193X1	1 (A)		1	O-Ring	Joint torique	Junta de tipo O
16	1606735M1	1 (A)		1	Ring, Backup	Contre-joint	ContraJunta
17	3487207M1	1 (A)		1	O-Ring	Joint torique	Junta de tipo O
18	3484615M1	1 (A)		1	Ring	Anneau	Aro
19	3623371M1	1		1	Bearing	Coussinet	Cojinete
20	3484055M1	1 (A)		1	Ring	Anneau	Aro
21	3485185M1	1 (A)		1	Seal	Joint	Junta
22	3487015M1	1 (A)		1	Ring	Anneau	Aro
23	339608X1	1		1	Fitting, Grease	Graisneur	Engrasador
24	5004012M91	1		1	Rod, Piston	Tige de vérin	Vástago cilindro
25		24	Ref. 24	1	Rod, Piston	Tige de vérin	Vástago cilindro
26		24 (C)		1	Bushing	Bague	Anillo
27	3623373M91		(B)	1	Kit, Seal	Pochette de joints	Juego de juntas

A Contains items marked (A)
 Comprend les pièces marquées (A)
 Incluye las piezas marcadas (A)

C Part number to be advised
 Référence pièce à demander
 Indicar número de pieza

B Included in kit marked (B)
 Inclus dans jeu marqué (B)
 Incluido en juego marcado (B)



860 880 970 980
 TX860B

817 825 845 855 921 931

76037C02.1

6199042M3

1

Jan-06

Digger Hydraulics
Circuit Hydraulique Défonceuse
Circuito hidráulico equipo retro

Sideshift
Montage de Pelle Latéral
Excavadora de montaje horizontal

Telescopic Dipper
Balancier Téléscopique
Balancín telescópico

High Spec.
 High Spec.
 High Spec.

C-76037-03.1-A

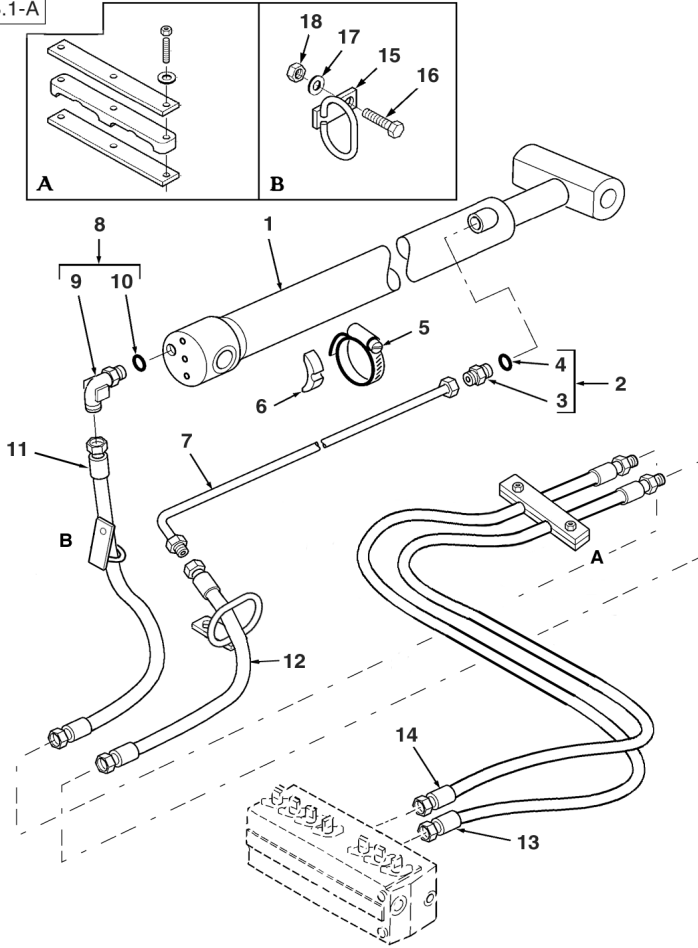

1	5000124M91	76037C04.1 1	1	Cylinder Assy	Ensemble de vérin	Gato, Conj.
2	835013M91		1	Connector Assy	Ensemble connexion	Conexión, Conj.
3		2 Ref. 2	1	Union	Union	Unión
4	835024M1	2	1	O-Ring	Joint torique	Junta de tipo O
5	3517733M1		1	Clamp	Collier de serrage	Argolla de cierre
6	L79937		1	Spacer	Entretoise	Travesa
7		(A,B)	1	Tube Assy	Tuyauterie	Conjunto de tubería
8		(A,B)	1	Elbow	Coude	Codo
9		8 (A,B) Ref. 8	1	Elbow	Coude	Codo
10		8 (A,B)	1	O-Ring	Joint torique	Junta de tipo O
11	6101738M91	Yellow	1	Hose Assy	Ensemble de flexible	Flexible, Conj.
12	6101737M91	Red	1	Hose Assy	Ensemble de flexible	Flexible, Conj.
13	6108767M91	Yellow	1	Hose Assy	Ensemble de flexible	Flexible, Conj.
14	6108766M91	Red	1	Hose Assy	Ensemble de flexible	Flexible, Conj.
15	6101491M92		2	Support Assy	Ensemble de support	Apoyadero, Conj.
16	339761X1	M8 x 25	2	Screw	Vis	Tornillo
17	390972X1	M8	2	Washer	Rondelle	Arandela
18	394367X1	M8	2	Nut, Lock	Écrou de blocage	Tuerca de retención

A Without Hose Burst
 Sans éclatement de tuyau
 Sin rotura de tubo flexible

B See hose burst section
 Voir la section éclatement de tuyau
 Ver la sección de rotura de tubo flexible



860 880 970 980
 TX860B

817 825 845 855 921 931

76037C03.1

6199042M3

1

Jan-06

Digger Hydraulics
Circuit Hydraulique Défonceuse
Circuito hidráulico equipo retro

Sideshift
Montage de Pelle Latéral
Excavadora de montaje horizontal

Dipper Cylinder
Vérin de Balancier
Gato de balancín

High Spec.
 High Spec.
 High Spec.

C-76037-04.1-A

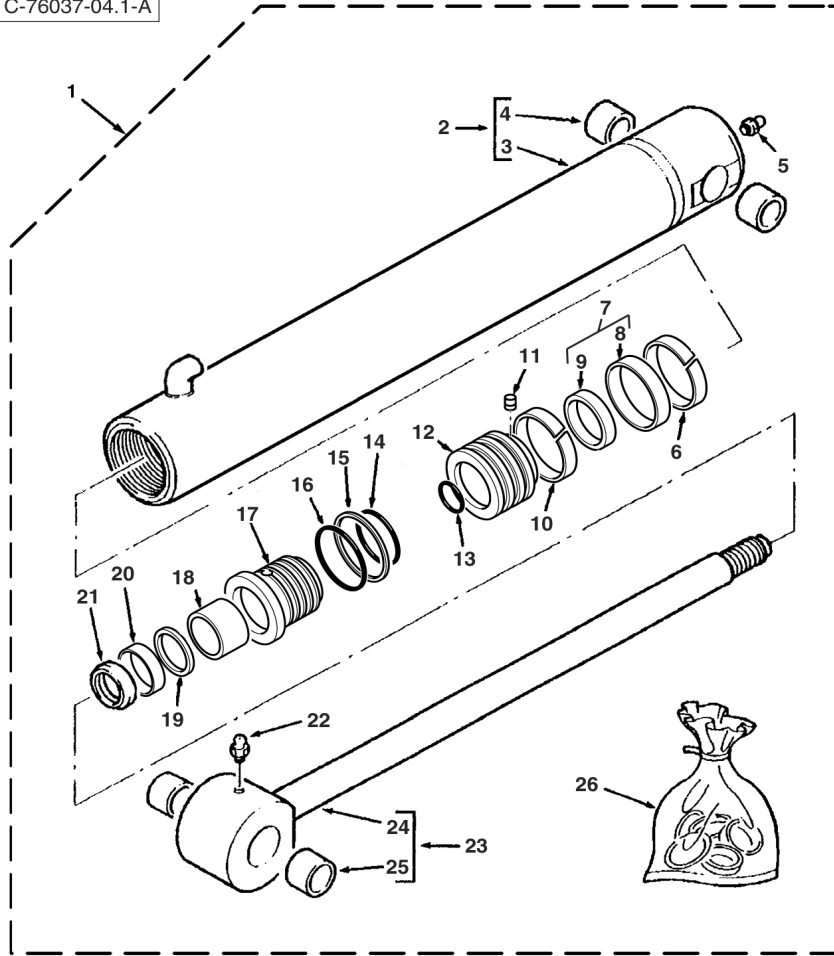

1	5000124M91		76037C03.1 1	1	Cylinder Assy	Ensemble de vérin	Gato, Conj.
2	5003982M91	1		1	Cylinder	Cylindre	Cilindro
3		2	Ref. 2	1	Tube, Cylinder	Cylindre de vérin	Cilindro de gato
4	3484843M1	2		1	Bush	Bague	Casquillo
5	339608X1	1		1	Fitting, Grease	Graisneur	Engrasador
6	3485891M1	1 (A)		1	Ring	Anneau	Aro
7	3485247M91	1 (A)		1	Seal Assy	Ensemble de joint	Junta, Conj.
8		7	Ref. 7	1	Seal	Joint	Junta
9		7	Ref. 7	1	Ring	Anneau	Aro
10	3485891M1	1 (A)		1	Ring	Anneau	Aro
11	3402928M1	1		1	Screw	Vis	Tornillo
12	5003989M1	1		1	Piston	Piston	Pistón
13	3007182X1	1 (A)		1	O-Ring	Joint torique	Junta de tipo O
14	359196X1	1 (A)		1	O-Ring	Joint torique	Junta de tipo O
15	378545X1	1 (A)		1	Ring	Anneau	Aro
16	3487908M1	1 (A)		1	O-Ring	Joint torique	Junta de tipo O
17	5003988M1	1		1	Bearing	Coussinet	Cojinete
18	3623193M1	1 (A)		1	Ring	Anneau	Aro
19	3443388M1	1 (A)		1	Ring	Anneau	Aro
20	3443472M1	1 (A)		1	Seal	Joint	Junta
21	3403385M1	1 (A)		1	Ring, Wiper	Joint de racler	Junta raspador
22	339608X1	1		1	Fitting, Grease	Graisneur	Engrasador
23	5003985M91	1		1	Rod, Piston	Tige de vérin	Vástago cilindro
24		23	Ref. 23	1	Rod, Piston	Tige de vérin	Vástago cilindro
25	3484843M1	23		1	Bush	Bague	Casquillo
26	5004401M91		(B)	1	Kit, Seal	Pochette de joints	Juego de juntas

A Included in kit marked (B)
 Inclus dans jeu marqué (B)
 Incluido en juego marcado (B)

B Contains items marked (A)
 Comprend les pièces marquées (A)
 Incluye las piezas marcadas (A)



860 880 970 980
 TX860B

817 825 845 855 921 931

76037C04.1

6199042M3

1

Jan-06

Digger Hydraulics
Circuit Hydraulique Défonceuse
Circuito hidráulico equipo retro

Sideshift
Montage de Pelle Latéral
Excavadora de montaje horizontal

Boom
 Flèche
 Pluma

High Spec.
 High Spec.
 High Spec.

C-76037-05.1-A

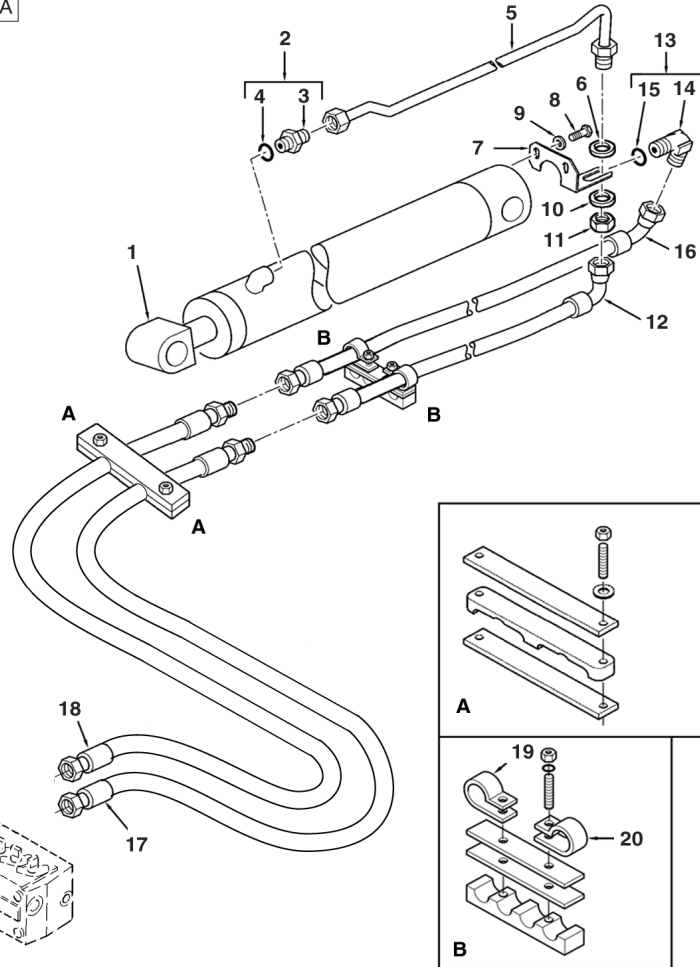

1	5000122M91	76037C06.1 1 4.5m Boom	1	Cylinder Assy	Ensemble de vérin	Gato, Conj.
2	835013M91		1	Connector Assy	Ensemble connexion	Conexión, Conj.
3		Ref. 2	1	Union	Union	Unión
4	835024M1		1	O-Ring	Joint torique	Junta de tipo O
5		(A,B)	1	Tube Assy	Tuyauterie	Conjunto de tubería
6		(A,B)	1	Washer	Rondelle	Arandela
7		(A,B)	1	Bracket	Patte de fixation	Pata de fijación
8	339228X1	M8 x 12	2	Screw	Vis	Tornillo
9	339374X1	M8	2	Washer, Lock	Rondelle de blocage	Arandela de freno
10		(A,B)	1	Washer	Rondelle	Arandela
11		(A,B)	1	Nut	Écrou	Tuerca
12		(A,B)Orange	1	Hose Assy	Ensemble de flexible	Flexible, Conj.
13		(A,B)	1	Elbow	Coude	Codo
14		(A,B) Ref. 13	1	Elbow	Coude	Codo
15		13 (A,B)	1	O-Ring	Joint torique	Junta de tipo O
16	6101736M92	Blue	1	Hose Assy	Ensemble de flexible	Flexible, Conj.
17	6108761M91	Orange	1	Hose Assy	Ensemble de flexible	Flexible, Conj.
18	6108760M91	Blue	1	Hose Assy	Ensemble de flexible	Flexible, Conj.
19	515-23270		1	Clip	Clip	Clip
20	515-23206		1	Clip	Clip	Clip

A Without Hose Burst
 Sans éclatement de tuyau
 Sin rotura de tubo flexible

B See hose burst section
 Voir la section éclatement de tuyau
 Ver la sección de rotura de tubo flexible



860 880 970 980
 TX860B

817 825 845 855 921 931

76037C05.1

6199042M3

1

Jan-06

Digger Hydraulics
Circuit Hydraulique Défonceuse
Circuito hidráulico equipo retro

Sideshift
Montage de Pelle Latéral
Excavadora de montaje horizontal

Boom Cylinder
Vérin de Flèche
Gato de pluma

High Spec.
 High Spec.
 High Spec.

C-76037-06.1-A

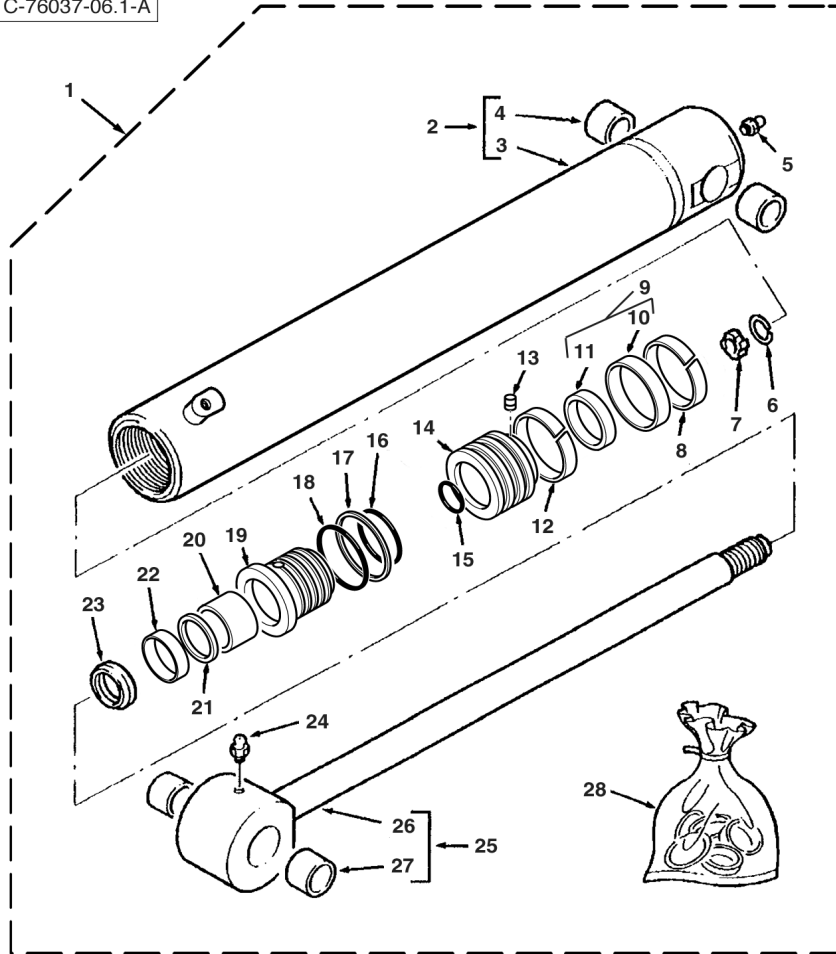

1	5000122M91	76037C05.1 1 4.5m Boom	1	Cylinder Assy	Ensemble de vérin	Gato, Conj.
2	5003912M91	1	1	Cylinder	Cylindre	Cilindro
3		2	1	Tube, Cylinder	Cylindre de vérin	Cilindro de gato
4		2 (C)	2	Bushing	Bague	Anillo
5	339608X1	1	1	Fitting, Grease	Graisser	Engrasador
6	1609899M1	1	1	Ring, Snap	Anneau d'arrêt	Anillo de resorte
7	1609328M1	1	1	Ring	Anneau	Aro
8	3403852M1	1 (A)	2	Ring	Anneau	Aro
9	3485213M91	1 (A)	1	Seal Assy	Ensemble de joint	Junta, Conj.
10		9	1	Seal	Joint	Junta
11		9	1	Seal	Joint	Junta
13	3402928M1	1	1	Screw	Vis	Tornillo
14	3484189M1	1	1	Piston	Piston	Pistón
15	3007182X1	1 (A)	1	O-Ring	Joint torique	Junta de tipo O
16	359203X1	1 (A)	1	O-Ring	Joint torique	Junta de tipo O
17	367120X1	1 (A)	1	Ring	Anneau	Aro
18	3487909M1	1 (A)	1	O-Ring	Joint torique	Junta de tipo O
19	3623202M1	1	1	Bearing	Coussinet	Cojinete
20	3623193M1	1 (A)	1	Ring	Anneau	Aro
21	3443388M1	1 (A)	1	Ring	Anneau	Aro
22	3443472M1	1 (A)	1	Seal	Joint	Junta
23	3403385M1	1 (A)	1	Ring, Wiper	Joint de racleur	Junta raspador
24	339608X1	1	1	Fitting, Grease	Graisser	Engrasador
25	3441629M91	1	1	Rod, Piston	Tige de vérin	Vástago cilindro
26		25	1	Rod, Piston	Tige de vérin	Vástago cilindro
27	3484843M1	25	1	Bush	Bague	Casquillo
28	3623589M91	(B)	1	Kit, Seal	Pochette de joints	Juego de juntas

A Included in kit marked (B)
 Inclus dans jeu marqué (B)
 Incluido en juego marcado (B)
 C Part number to be advised
 Référence pièce à demander
 Indicar número de pieza

B Contains items marked (A)
 Comprend les pièces marquées (A)
 Incluye las piezas marcadas (A)



860 880 970 980
 TX860B

817 825 845 855 921 931

76037C06.1

6199042M3

1

Jan-06

Digger Hydraulics
Circuit Hydraulique Défonceuse
Circuito hidráulico equipo retro

Sideshift
Montage de Pelle Latéral
Excavadora de montaje horizontal

Swing Components
Organes de Rotation
Componentes de rotación

High Spec.
 High Spec.
 High Spec.

C-76037-07.1-A

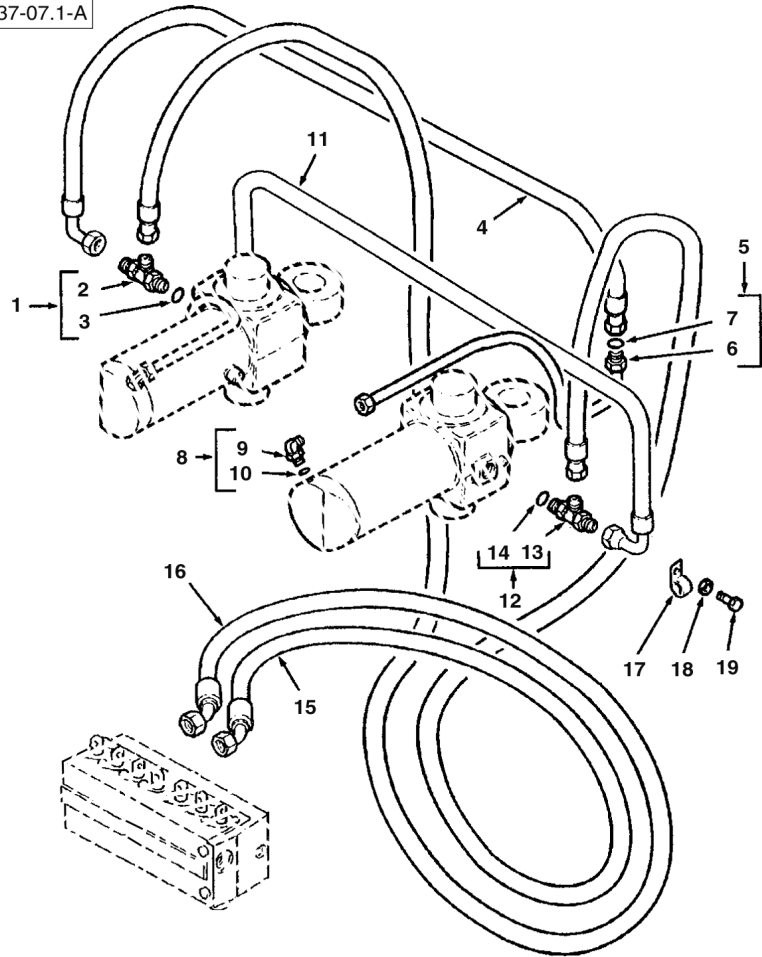

1	358728X91		1	Tee	Raccord en T	Te	
2		1	▶ Ref. 1	1	Tee	Raccord en T	Te
3	831497M1	1		1	O-Ring	Joint torique	Junta de tipo O
4	6100716M91	840 mm		1	Hose Assy	Ensemble de flexible	Flexible, Conj.
5	6100587M91	◀		1	Tube Assy	Tuyauterie	Conjunto de tubería
5	6100589M91	▶		1	Tube Assy	Tuyauterie	Conjunto de tubería
6		5	▶ Ref. 5	1	Tube	Tube	Tubo
7	394923X1	5		1	O-Ring	Joint torique	Junta de tipo O
8	357197X91			2	Elbow, 90°	Coude à 90°	Codo, 90°
9		8	▶ Ref. 8	1	Elbow	Coude	Codo
10	831452M1	8		1	O-Ring	Joint torique	Junta de tipo O
11	6100716M91	840 mm		1	Hose Assy	Ensemble de flexible	Flexible, Conj.
12	358728X91			1	Tee	Raccord en T	Te
13		12	▶ Ref. 12	1	Tee	Raccord en T	Te
14	831497M1	12		1	O-Ring	Joint torique	Junta de tipo O
15	6107456M91	◀ 1745 mm		1	Hose Assy	Ensemble de flexible	Flexible, Conj.
16	6107455M91	▶ 1745 mm		1	Hose Assy	Ensemble de flexible	Flexible, Conj.
17	3517114M2			2	Clip, Mounting	Collier de fixation	Argolla de fijación
18	385361X1	M8		2	Washer	Rondelle	Arandela
19	339228X1	M8 x 12		2	Screw	Vis	Tornillo



860 880 970 980
 TX860B

817 825 845 855 921 931

76037C07.1

6199042M3

1

Jan-06

Digger Hydraulics
Circuit Hydraulique Défonceuse
Circuito hidráulico equipo retro

Sideshift
Montage de Pelle Latéral
Excavadora de montaje horizontal

Clamp
 Collier
 Abrazadera

High Spec.
 High Spec.
 High Spec.

C-76037-08.1-A

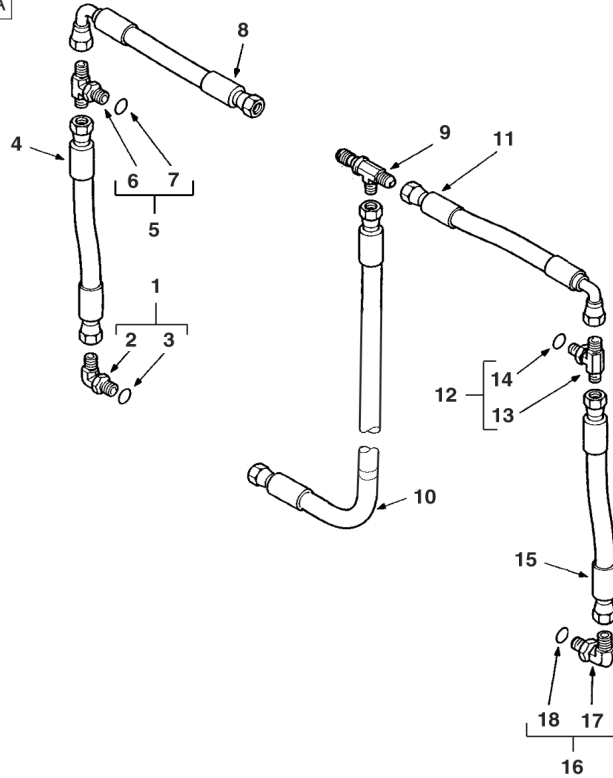

1	358761X91			1	Elbow, 90°	Coude à 90°	Codo, 90°
2		1	➡ Ref. 1	1	Elbow	Coude	Codo
3	831496M1	1		1	O-Ring	Joint torique	Junta de tipo O
4	3521882M94			1	Hose Assy	Ensemble de flexible	Flexible, Conj.
5	358827X91			1	Tee	Raccord en T	Te
6		5	➡ Ref. 5	1	Tee	Raccord en T	Te
7	831496M1	5		1	O-Ring	Joint torique	Junta de tipo O
8	3521878M93			1	Hose Assy	Ensemble de flexible	Flexible, Conj.
9	356558X1			1	Tee	Raccord en T	Te
10	6110207M91	Clamp		1	Hose Assy	Ensemble de flexible	Flexible, Conj.
11	3521878M93			1	Hose Assy	Ensemble de flexible	Flexible, Conj.
12	358827X91			1	Tee	Raccord en T	Te
13		12	➡ Ref. 12	1	Tee	Raccord en T	Te
14	831496M1	12		1	O-Ring	Joint torique	Junta de tipo O
15	3521882M94			1	Hose Assy	Ensemble de flexible	Flexible, Conj.
16	358761X91			1	Elbow, 90°	Coude à 90°	Codo, 90°
17		16	➡ Ref. 16	1	Elbow	Coude	Codo
18	831496M1	16		1	O-Ring	Joint torique	Junta de tipo O



860 880 970 980
 TX860B

817 825 845 855 921 931

76037C08.1

6199042M3

1

Jan-06

Digger Hydraulics
Circuit Hydraulique Défonceuse
Circuito hidráulico equipo retro

Sideshift
Montage de Pelle Latéral
Excavadora de montaje horizontal

Attachment
Attache
Equipo

C-76037-09.1-A

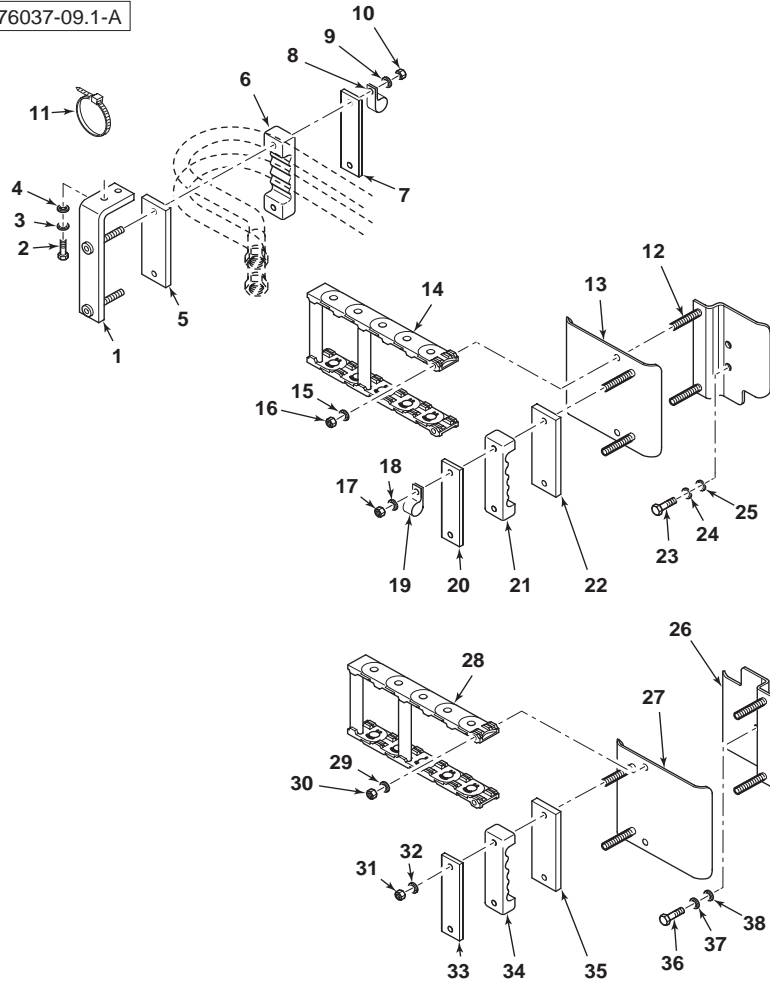

1	6107934M91		2	Bracket, Clamp	Bride de fixation	Brida de fijación
2	339761X1	M8 x 25	4	Screw	Vis	Tornillo
3	390972X1	M8	4	Washer	Rondelle	Arandela
4	339374X1	M8	4	Washer, Lock	Rondelle de blocage	Arandela de freno
5	6102197M1		2	Pad, Rubber	Plaque de caoutchouc	Placa, Caucho
6	6101216M1	◀	1	Clamp	Collier de serrage	Argolla de cierre
6	6101859M1	▶	1	Clamp	Collier de serrage	Argolla de cierre
7	6101215M1		2	Plate	Plaque	Placa
8	515-22159		1	Clip, Mounting	Collier de fixation	Argolla de fijación
9	390972X1	M8	4	Washer	Rondelle	Arandela
10	394367X1	M8	4	Nut, Lock	Écrou de blocage	Tuerca de retención
11	1862425M1		1	Tie, Cable	Attache câble	Enlace de Cable
12	6102307M91	▶	1	Bracket, Clamp	Bride de fixation	Brida de fijación
13	6101424M91		1	Plate Assy	Ensemble de plaque	Placa, Conj.
14	6102199M92		1	Chain	Chaîne	Cadena
15	390971X1	M6	2	Washer	Rondelle	Arandela
16	1441500X1	M6	2	Nut, Lock	Écrou de blocage	Tuerca de retención
17	394367X1	M8	2	Nut, Lock	Écrou de blocage	Tuerca de retención
18	390972X1	M8	2	Washer	Rondelle	Arandela
19	515-22159		1	Clip, Mounting	Collier de fixation	Argolla de fijación
20	6101215M1		1	Plate	Plaque	Placa
21	6101859M1		1	Clamp	Collier de serrage	Argolla de cierre
22	6102197M1		1	Pad, Rubber	Plaque de caoutchouc	Placa, Caucho
23	3009492X1	M10 x 25	2	Screw	Vis	Tornillo
24	339376X1	M10	2	Washer, Lock	Rondelle de blocage	Arandela de freno
25	390734X1	M10	2	Washer	Rondelle	Arandela
26	6102308M91	◀	1	Bracket, Clamp	Bride de fixation	Brida de fijación
27	6101424M91		1	Plate Assy	Ensemble de plaque	Placa, Conj.
28	6102199M92		1	Chain	Chaîne	Cadena
29	390971X1	M6	2	Washer	Rondelle	Arandela
30	1441500X1	M6	2	Nut, Lock	Écrou de blocage	Tuerca de retención
31	394367X1	M8	2	Nut, Lock	Écrou de blocage	Tuerca de retención
32	390972X1	M8	2	Washer	Rondelle	Arandela
33	6101215M1		1	Plate	Plaque	Placa
34	6101216M1	◀	1	Clamp	Collier de serrage	Argolla de cierre
35	6102197M1		1	Pad, Rubber	Plaque de caoutchouc	Placa, Caucho
36	3009492X1	M10 x 25	2	Screw	Vis	Tornillo
37	339376X1	M10	2	Washer, Lock	Rondelle de blocage	Arandela de freno
38	390734X1	M10	2	Washer	Rondelle	Arandela



860 880 970 980
 TX860B

817 825 845 855 921 931

76037C09.1

6199042M3

1

Jan-06

Digger Stabilisers
Stabilisateurs
Estabilizadores

Centremount
Montage de Pelle Central
Excavadora de montaje central

Flip-over Feet
Inverse-par-dessus Pieds
Eche al aire sobre Pies

C-70002-01.1-A

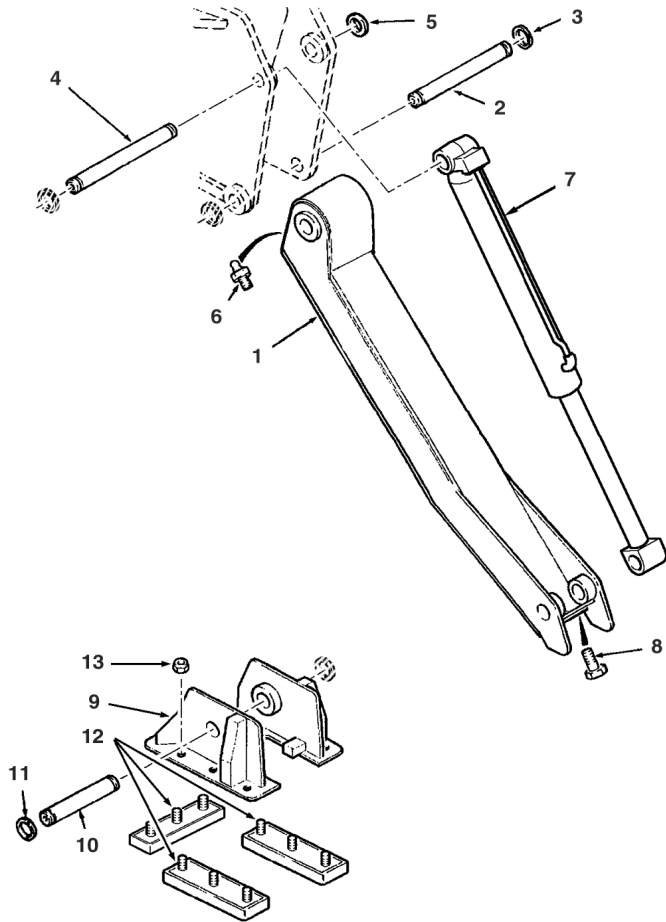

1	3519717M91		2	Leg	Jambe	Pierna
2	3517333M2	44 x 308 mm	2	Pin	Axe	Pasador
3	3517792M1		4	Ring, Snap	Anneau d'arrêt	Anillo de resorte
4	3519722M1	38 x 250 mm	2	Pin	Axe	Pasador
5	3517790M1		4	Ring, Snap	Anneau d'arrêt	Anillo de resorte
6	339608X1		2	Fitting, Grease	Graisneur	Engrasador
7		70002C02.1 1	2	Cylinder	Cylindre	Cilindro
8	391178X1	M10 x 10	4	Screw	Vis	Tornillo
9	6108908M91		2	Foot	Pied	Pie
10	3517331M3	38 x 274 mm	2	Pin	Axe	Pasador
11	3517790M1		4	Ring, Snap	Anneau d'arrêt	Anillo de resorte
12	6108233M91		6	Pad, Rubber	Plaque de caoutchouc	Placa, Caucho
13	1442739X1		18	Nut	Écrou	Tuerca



820 860 880 970 980
TX760B TX860B
TX870B TX970B

801 802 803 804 809 810 811 812 813 814 815 816 821 822 823 824 831 832 841
842 843 844 851 852 853 854 922 923 932

70002C01.1

6199042M3

1

Jan-06

Digger Stabilisers
Stabilisateurs
Estabilizadores

Centremount
Montage de Pelle Central
Excavadora de montaje central

Hydraulic Installation
Installation hydraulique
La Instalación hidráulica

C-70002-02.1-A

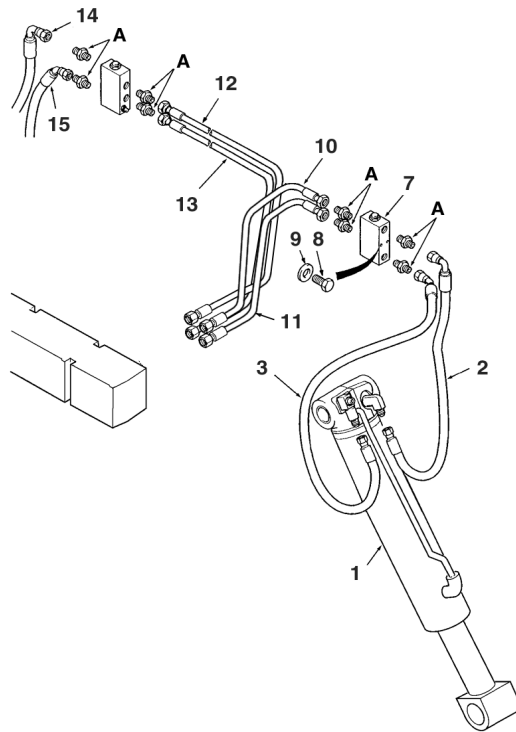
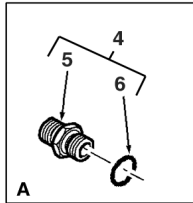

1	3622612M91	70002C01.1 1 70002C03.1 1	2	Cylinder Assy	Ensemble de vérin	Gato, Conj.
2	3519899M91	825 mm	1	Hose Assy	Ensemble de flexible	Flexible, Conj.
3	3517282M92	825 mm	1	Hose Assy	Ensemble de flexible	Flexible, Conj.
4	3519179M91		8	Connector Assy	Ensemble connexion	Conexión, Conj.
5		1	1	Connector	Connecteur	Conector
6	831452M1	1	1	O-Ring	Joint torique	Junta de tipo O
7	3518653M91	70002C04.1 1	2	Valve, Lockout	Soupape verrouillage	Válvula de bloqueo.
8	339804X1	M6 x 25	4	Screw	Vis	Tornillo
9	339375X1	M6	4	Washer, Lock	Rondelle de blocage	Arandela de freno
10	6107673M91		1	Hose Assy	Ensemble de flexible	Flexible, Conj.
11	6107673M91		1	Hose Assy	Ensemble de flexible	Flexible, Conj.
12	6107714M91		1	Hose Assy	Ensemble de flexible	Flexible, Conj.
13	6107164M92		1	Hose Assy	Ensemble de flexible	Flexible, Conj.
14	3519899M91	825 mm	1	Hose Assy	Ensemble de flexible	Flexible, Conj.
15	3517282M92	825 mm	1	Hose Assy	Ensemble de flexible	Flexible, Conj.



820 860 880 970 980
 TX760B TX860B
 TX870B TX970B

801 802 803 804 809 810 811 812 813 814 815 816 821 822 823 824 831 832 841
 842 843 844 851 852 853 854 922 923 932

70002C02.1

6199042M3

1

Jan-06

Digger Stabilisers
Stabilisateurs
Estabilizadores

Centremount
Montage de Pelle Central
Excavadora de montaje central

Stabilizer Cylinder
Vérin de Stabilisateur
Gato de estabilizador

C-70002-03.1-A

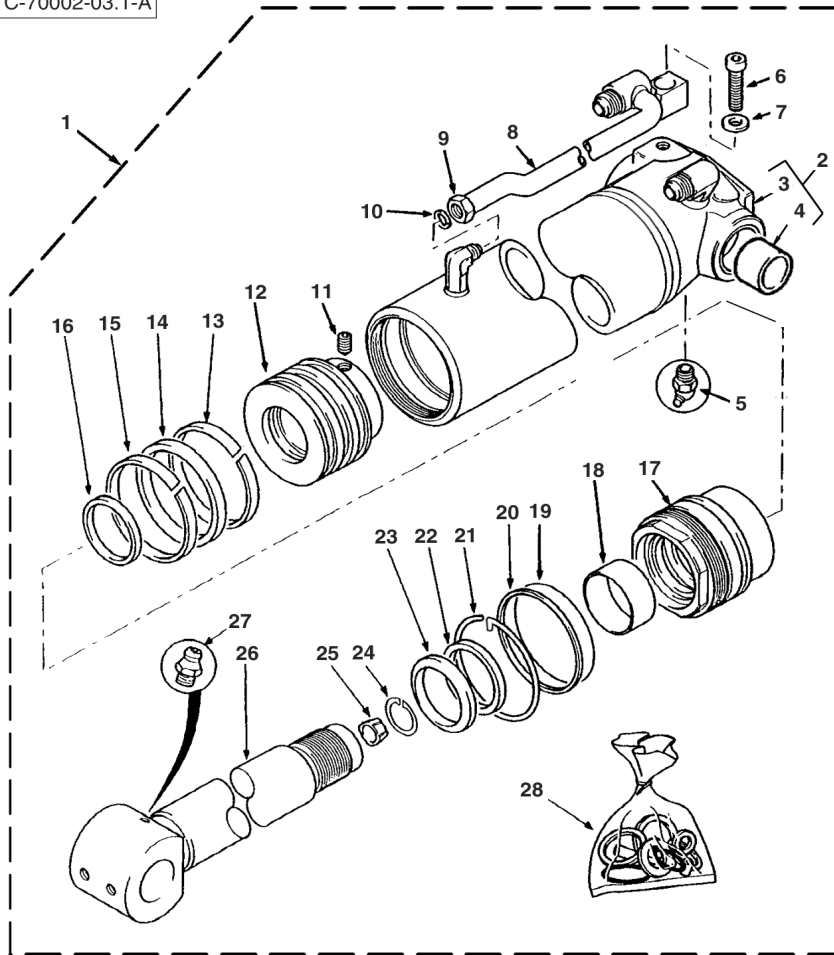

1	3622612M91	70002C01.1 7 70002C02.1 1	2	Cylinder Assy	Ensemble de vérin	Gato, Conj.
2	3624726M91	1	1	Tube, Cylinder	Cylindre de vérin	Cilindro de gato
3		2	1	Tube, Cylinder	Cylindre de vérin	Cilindro de gato
4	1606012M1	2	2	Bushing	Bague	Anillo
5	19575X	1	1	Fitting, Grease	Graisneur	Engrasador
6	3000258X1	1	1	Bolt	Boulon	Perno
7	390734X1	1	1	Washer	Rondelle	Arandela
8	3624727M91	1	1	Tube Assy	Tuyauterie	Conjunto de tubería
9	3624728M1	1	1	Nut	Écrou	Tuerca
10	3624729M1	1	1	Ring	Anneau	Aro
11	3402928M1	1	1	Screw	Vis	Tornillo
12	3484432M1	1	1	Piston, Cylinder	Piston de vérin	Pistón de gato
13	1033695M1	1 (A)	1	Ring	Anneau	Aro
14	5002310M1	1 (A)	1	Seal	Joint	Junta
15	1033695M1	1 (A)	1	Ring	Anneau	Aro
16	359185X1	1 (A)	1	O-Ring	Joint torique	Junta de tipo O
17	3623178M1	1	1	Gland, Cylinder	Palier de vérin	Palier de gato
18	3402380M1	1 (A)	1	Bushing	Bague	Anillo
19	359193X1	1 (A)	1	O-Ring	Joint torique	Junta de tipo O
20	1606735M1	1 (A)	1	Ring, Backup	Contre-joint	ContraJunta
21	3404681M1	1	1	Wire	Fil	Hilo
22	1606495M1	1 (A)	1	Seal	Joint	Junta
23	834500M1	1 (A)	1	Seal, Wiper	Joint de racleur	Junta raspador
24	3186587M1	1	1	Ring, Snap	Anneau d'arrêt	Anillo de resorte
25	3186586M1	1	1	Ring	Anneau	Aro
26	3441744M91	1	1	Rod, Piston	Tige de vérin	Vástago cilindro
27	MP1056	1	1	Fitting, Grease	Graisneur	Engrasador
28	3484453M94	(B)	1	Kit, Seal	Pochette de joints	Juego de juntas

A Included in kit marked (B)
 Inclus dans jeu marqué (B)
 Incluido en juego marcado (B)

B Contains items marked (A)
 Comprend les pièces marquées (A)
 Incluye las piezas marcadas (A)



820 860 880 970 980
 TX760B TX860B
 TX870B TX970B

801 802 803 804 809 810 811 812 813 814 815 816 821 822 823 824 831 832 841
 842 843 844 851 852 853 854 922 923 932

70002C03.1

6199042M3

1

Jan-06

Digger Stabilisers
Stabilisateurs
Estabilizadores

Centremount
Montage de Pelle Central
Excavadora de montaje central

Lock-out valve
Soupape verrouillage
Válvula de bloqueo.

C-70002-04.1-A

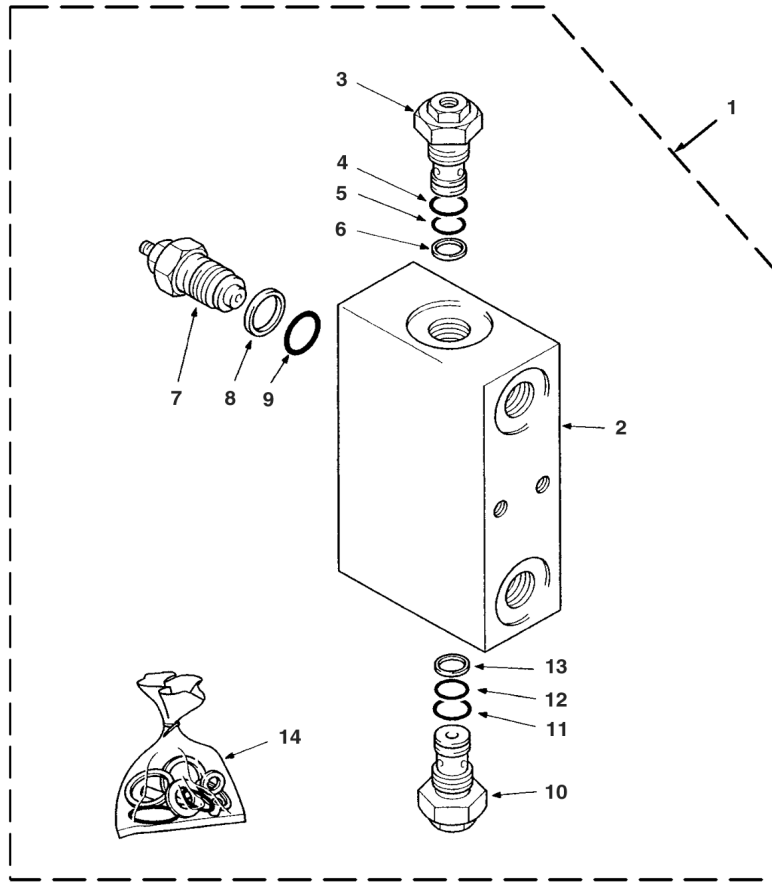

1	3518653M91		70002C02.1 7	2	Valve, Lockout	Soupape verrouillage	Válvula de bloqueo.
2		1	Ref. 1	1	Body	Corps	Cuerpo
3	6190560M91	1		1	Valve, Check	Clapet anti-retour	Válvula de parada
4		1 (A)		1	O-Ring	Joint torique	Junta de tipo O
5		1 (A)		1	O-Ring	Joint torique	Junta de tipo O
6		1 (A)		1	Ring, Backup	Contre-joint	Contrajunta
7	6190561M91	1		1	Valve, Relief	Soupape, décharge	Válvula, Descarga
8		1 (A)		1	O-Ring	Joint torique	Junta de tipo O
9		1 (A)		1	O-Ring	Joint torique	Junta de tipo O
10	6190560M91	1		1	Valve, Check	Clapet anti-retour	Válvula de parada
11		1 (A)		1	O-Ring	Joint torique	Junta de tipo O
12		1 (A)		1	O-Ring	Joint torique	Junta de tipo O
13		1 (A)		1	Ring, Backup	Contre-joint	Contrajunta
14	6190487M91		(B)	1	Kit, Seal	Pochette de joints	Juego de juntas

A Included in kit marked (B)
 Inclus dans jeu marqué (B)
 Incluido en juego marcado (B)

B Contains items marked (A)
 Comprend les pièces marquées (A)
 Incluye las piezas marcadas (A)



820 860 880 970 980
 TX760B TX860B
 TX870B TX970B

801 802 803 804 809 810 811 812 813 814 815 816 821 822 823 824 831 832 841
 842 843 844 851 852 853 854 922 923 932

70002C04.1

6199042M3

1

Jan-06

Digger Stabilisers
Stabilisateurs
Estabilizadores

Centremount
Montage de Pelle Central
Excavadora de montaje central

Standard Feet
Pieds standard
Los Pies uniformes

C-70003-01.1-A

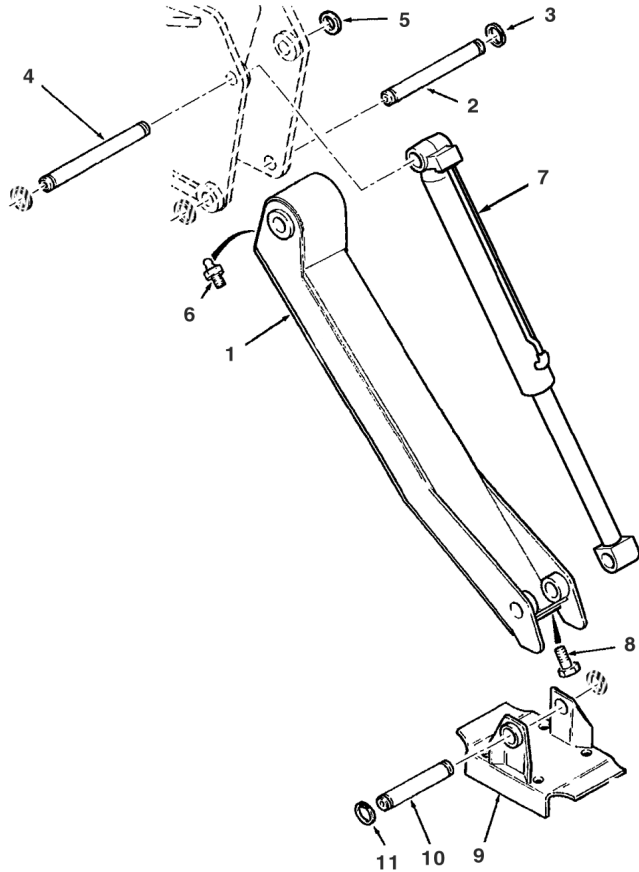

1	3519717M91		2	Leg	Jambe	Pierna
2	3517333M2	44 x 308 mm	2	Pin	Axe	Pasador
3	3517792M1		4	Ring, Snap	Anneau d'arrêt	Anillo de resorte
4	3519722M1	38 x 250 mm	2	Pin	Axe	Pasador
5	3517790M1		4	Ring, Snap	Anneau d'arrêt	Anillo de resorte
6	339608X1		2	Fitting, Grease	Graisneur	Engrasador
7		70003C02.1 1	2	Cylinder	Cylindre	Cilindro
8	391178X1	M10 x 10	4	Screw	Vis	Tornillo
9	6107955M91		2	Foot	Pied	Pie
10	3517330M3	38 x 256 mm	2	Pin	Axe	Pasador
11	3517790M1		4	Ring, Snap	Anneau d'arrêt	Anillo de resorte



820 860 880 970 980
TX760B TX860B
TX870B TX970B

801 802 803 804 813 814 815 816 821 822 823 824 831 832 841 842 843 844 851
852 853 854 922 923 932

70003C01.1

6199042M3

1

Jan-06

Digger Stabilisers
Stabilisateurs
Estabilizadores

Centremount
Montage de Pelle Central
Excavadora de montaje central

Hydraulic Installation
Installation hydraulique
La Instalación hidráulica

C-70003-02.1-A

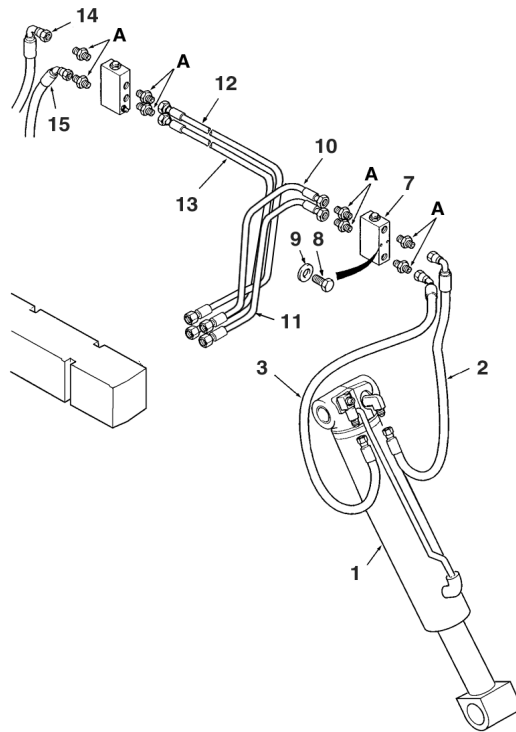
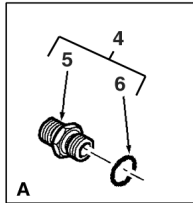

1	3622612M91	70003C01.1 1 70003C03.1 1	2	Cylinder Assy	Ensemble de vérin	Gato, Conj.
2	3519899M91	825 mm	1	Hose Assy	Ensemble de flexible	Flexible, Conj.
3	3517282M92	825 mm	1	Hose Assy	Ensemble de flexible	Flexible, Conj.
4	3519179M91		8	Connector Assy	Ensemble connexion	Conexión, Conj.
5		1	1	Connector	Connecteur	Conector
6	831452M1	1	1	O-Ring	Joint torique	Junta de tipo O
7	3518653M91	70003C04.1 1	2	Valve, Lockout	Soupape verrouillage	Válvula de bloqueo.
8	339804X1	M6 x 25	4	Screw	Vis	Tornillo
9	339375X1	M6	4	Washer, Lock	Rondelle de blocage	Arandela de freno
10	6107673M91		1	Hose Assy	Ensemble de flexible	Flexible, Conj.
11	6107673M91		1	Hose Assy	Ensemble de flexible	Flexible, Conj.
12	6107714M91		1	Hose Assy	Ensemble de flexible	Flexible, Conj.
13	6107164M92		1	Hose Assy	Ensemble de flexible	Flexible, Conj.
14	3519899M91	825 mm	1	Hose Assy	Ensemble de flexible	Flexible, Conj.
15	3517282M92	825 mm	1	Hose Assy	Ensemble de flexible	Flexible, Conj.



820 860 880 970 980
 TX760B TX860B
 TX870B TX970B

801 802 803 804 813 814 815 816 821 822 823 824 831 832 841 842 843 844 851
 852 853 854 922 923 932

70003C02.1

6199042M3

1

Jan-06

Digger Stabilisers
Stabilisateurs
Estabilizadores

Centremount
Montage de Pelle Central
Excavadora de montaje central

Lock-out valve
Soupape verrouillage
Válvula de bloqueo.

C-70003-04.1-A

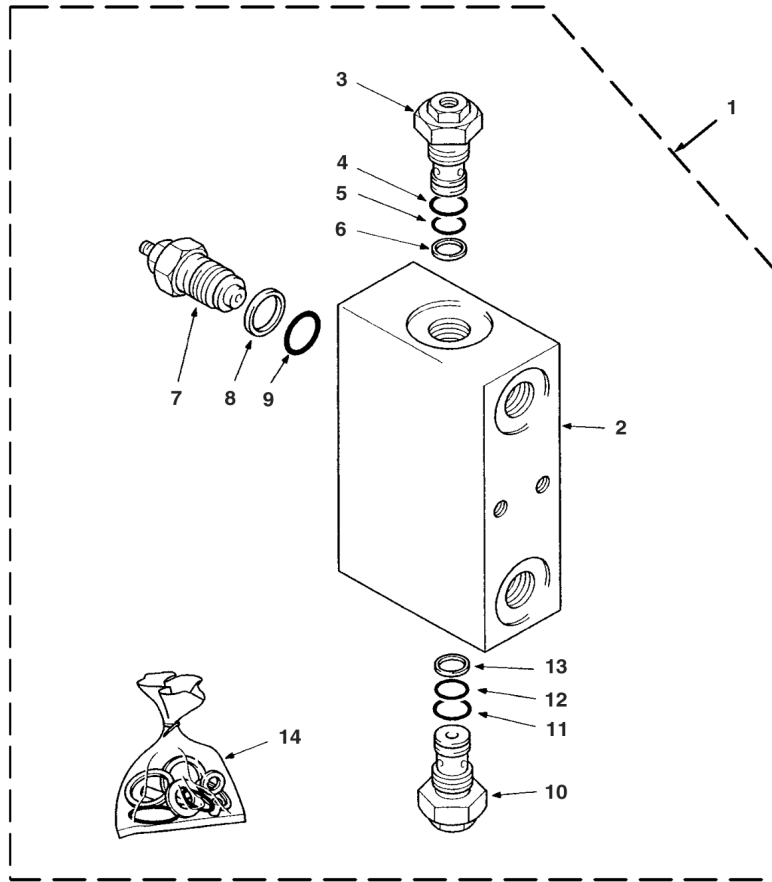

1	3518653M91		70003C02.1 7	2	Valve, Lockout	Soupape verrouillage	Válvula de bloqueo.
2		1	Ref. 1	1	Body	Corps	Cuerpo
3	6190560M91	1		1	Valve, Check	Clapet anti-retour	Válvula de parada
4		1 (A)		1	O-Ring	Joint torique	Junta de tipo O
5		1 (A)		1	O-Ring	Joint torique	Junta de tipo O
6		1 (A)		1	Ring, Backup	Contre-joint	Contrajunta
7	6190561M91	1		1	Valve, Relief	Soupape, décharge	Válvula, Descarga
8		1 (A)		1	O-Ring	Joint torique	Junta de tipo O
9		1 (A)		1	O-Ring	Joint torique	Junta de tipo O
10	6190560M91	1		1	Valve, Check	Clapet anti-retour	Válvula de parada
11		1 (A)		1	O-Ring	Joint torique	Junta de tipo O
12		1 (A)		1	O-Ring	Joint torique	Junta de tipo O
13		1 (A)		1	Ring, Backup	Contre-joint	Contrajunta
14	6190487M91		(B)	1	Kit, Seal	Pochette de joints	Juego de juntas

A Included in kit marked (B)
 Inclus dans jeu marqué (B)
 Incluido en juego marcado (B)

B Contains items marked (A)
 Comprend les pièces marquées (A)
 Incluye las piezas marcadas (A)



820 860 880 970 980
 TX760B TX860B
 TX870B TX970B

801 802 803 804 813 814 815 816 821 822 823 824 831 832 841 842 843 844 851
 852 853 854 922 923 932

70003C04.1

6199042M3

1

Jan-06

Digger Stabilisers
Stabilisateurs
Estabilizadores

Sideshift
Montage de Pelle Latéral
Excavadora de montaje horizontal

Mechanical Installation
Installation mécanique
La Instalación mecánica

C-70001-01.1-A

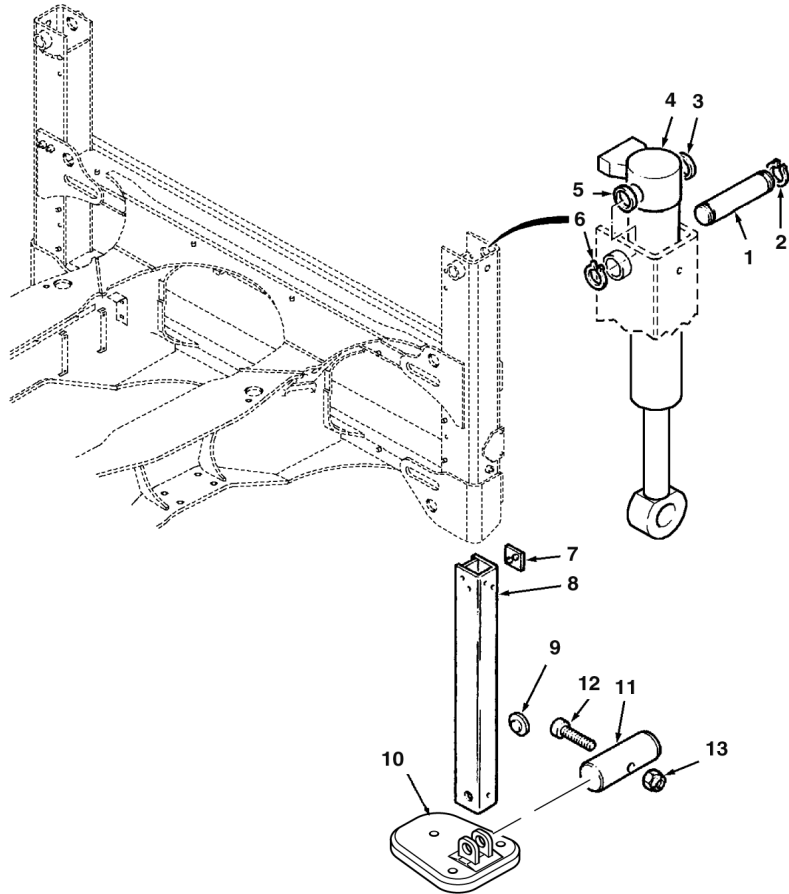

1	3521289M3	45 x 230 mm	2	Pin	Axe	Pasador
2	1440478X1		2	Ring, Snap	Anneau d'arrêt	Anillo de resorte
3	3521279M2		2	Spacer	Entretoise	Traviesa
4		<ul style="list-style-type: none"> ● 70001C02.1 1 ● 70001C03.1 1 	2	Cylinder Assy	Ensemble de vérin	Gato, Conj.
5	3521279M2		2	Spacer	Entretoise	Traviesa
6	1440478X1		2	Ring, Snap	Anneau d'arrêt	Anillo de resorte
7	6108417M1	3.6 mm Green	X	Pad, Wear	Patin d'usure	Patin de desgaste
7	6108416M1	4 mm Blue	X	Pad, Wear	Patin d'usure	Patin de desgaste
7	3516684M2	4,5 mm Yellow	X	Pad, Wear	Patin d'usure	Patin de desgaste
7	3521199M3	5,0 mm Black	X	Pad, Wear	Patin d'usure	Patin de desgaste
7	3517077M1	5,5 mm Grey	X	Pad, Wear	Patin d'usure	Patin de desgaste
7	3518965M1	6,0 mm Natural	X	Pad, Wear	Patin d'usure	Patin de desgaste
7	3518936M1	6,5 mm Red	X	Pad, Wear	Patin d'usure	Patin de desgaste
8	6108420M91	Inner	2	Stem	Tige	Varilla
9	6108419M1	3.6 mm Green	X	Pad, Wear	Patin d'usure	Patin de desgaste
9	6108418M1	4 mm Blue	X	Pad, Wear	Patin d'usure	Patin de desgaste
9	3519712M1	4,5 mm Yellow	X	Pad, Wear	Patin d'usure	Patin de desgaste
9	3519713M1	5,0 mm Black	X	Pad, Wear	Patin d'usure	Patin de desgaste
9	3519714M1	5,5 mm Grey	X	Pad, Wear	Patin d'usure	Patin de desgaste
9	3519715M1	6,0 mm Natural	X	Pad, Wear	Patin d'usure	Patin de desgaste
9	3519716M1	6,5 mm Red	X	Pad, Wear	Patin d'usure	Patin de desgaste
10	6102864M1		2	Foot	Pied	Pie
11	3522879M2	45 x 122 mm	2	Pin	Axe	Pasador
12	1442169X1	M10 x 90	2	Screw	Vis	Tornillo
13	1440329X1	M10	2	Nut, Lock	Écrou de blocage	Tuerca de retención



820 860 880 970 980
TX760B TX860B

805 806 807 808 817 825 833 834 845 855 921 931

70001C01.1

6199042M3

1

Jan-06

Digger Stabilisers
Stabilisateurs
Estabilizadores

Sideshift
Montage de Pelle Latéral
Excavadora de montaje horizontal

Hydraulic Installation
Installation hydraulique
La Instalación hidráulica

C-70001-02.1-A

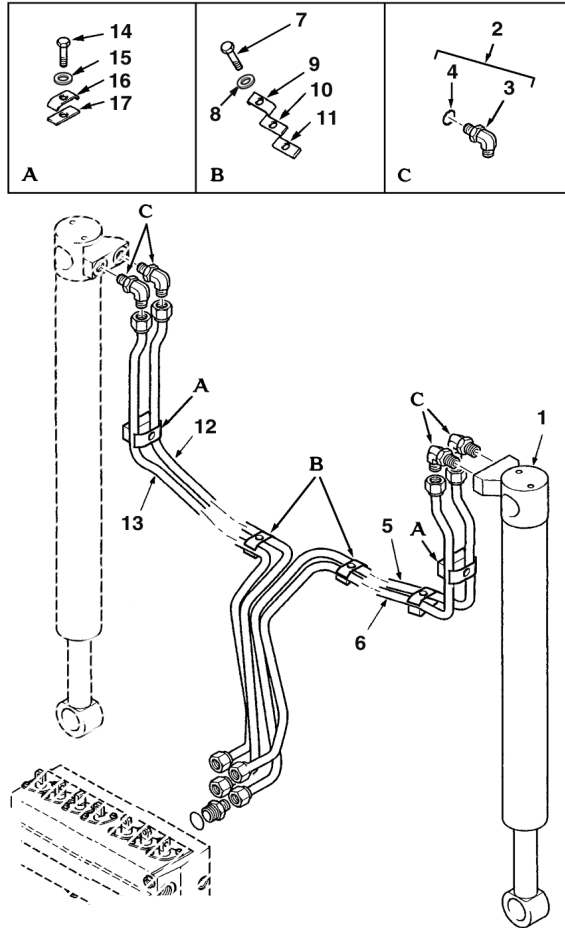

1	3622129M94	70001C03.1	1	2	Cylinder Assy	Ensemble de vérin	Gato, Conj.
2	372866X91			4	Elbow, 90°	Coude à 90°	Codo, 90°
3		2	Ref. 2	1	Elbow	Coude	Codo
4	835024M1	2		1	O-Ring	Joint torique	Junta de tipo O
5	6109563M91			1	Hose Assy	Ensemble de flexible	Flexible, Conj.
6	6109733M91			1	Hose Assy	Ensemble de flexible	Flexible, Conj.
7	339761X1	M8 x 25		4	Screw	Vis	Tornillo
8	390972X1	M8		4	Washer	Rondelle	Arandela
9	3522094M2			4	Bracket, Clamp	Bride de fixation	Brida de fijación
10	1458385M1			4	Pad, Rubber	Plaque de caoutchouc	Placa, Caucho
11	3518923M1			4	Spacer	Entretoise	Travesa
12	6109531M91			1	Hose Assy	Ensemble de flexible	Flexible, Conj.
13	6109734M91			1	Hose Assy	Ensemble de flexible	Flexible, Conj.
14	339123X1	M8 x 20		2	Bolt	Boulon	Perno
15	390972X1	M8		2	Washer	Rondelle	Arandela
16	3522094M2			2	Bracket, Clamp	Bride de fixation	Brida de fijación
17	1458385M1			2	Pad, Rubber	Plaque de caoutchouc	Placa, Caucho



820 860 880 970 980
 TX760B TX860B

805 806 807 808 817 825 833 834 845 855 921 931

70001C02.1

6199042M3

1

Jan-06

Digger Stabilisers
Stabilisateurs
Estabilizadores

Sideshift
Montage de Pelle Latéral
Excavadora de montaje horizontal

Stabilizer Cylinder
Vérin de Stabilisateur
Gato de estabilizador

C-70001-03.1-A

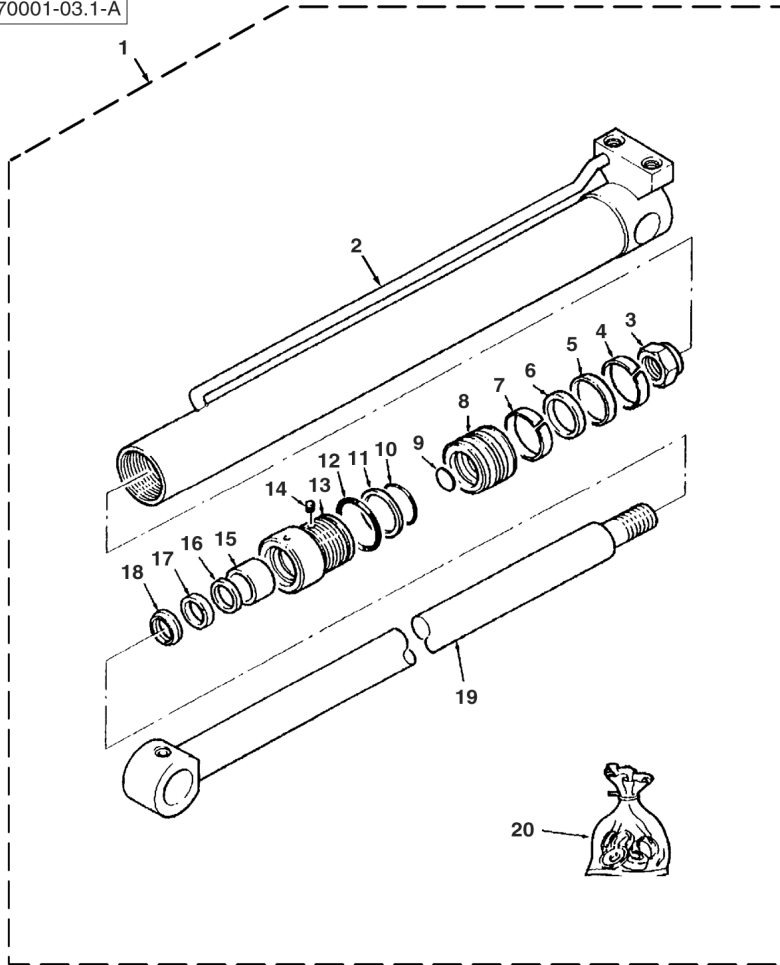

1	3622129M94		70001C01.1 1 70001C02.1 1	2	Cylinder Assy	Ensemble de vérin	Gato, Conj.
2	3623297M92	1		1	Tube, Cylinder	Cylindre de vérin	Cilindro de gato
3	1607690M1	1	M30	1	Nut	Écrou	Tuerca
4	3487067M1	1	(A)	1	Ring, Sealing	Bague d'étanchéité	Anillo, Estanqueidad
5	3485241M1	1	(A)	1	Ring	Anneau	Aro
6	3485254M1	1	(A)	1	Ring	Anneau	Aro
7	3487067M1	1		1	Ring, Sealing	Bague d'étanchéité	Anillo, Estanqueidad
8	3623299M1	1		1	Piston, Cylinder	Piston de vérin	Pistón de gato
9	359181X1	1	(A)	1	O-Ring	Joint torique	Junta de tipo O
10	359187X1	1	(A)	1	O-Ring	Joint torique	Junta de tipo O
11	1884170M1	1	(A)	1	Ring, Backup	Contre-joint	ContraJunta
12	3487205M1	1	(A)	1	O-Ring	Joint torique	Junta de tipo O
13	3623298M1	1		1	Gland, Cylinder	Palier de vérin	Palier de gato
14	3443386M1	1	(A)	1	Plug	Bouchon	Tapón
15	3491486M1	1	(A)	1	Bushing	Bague	Anillo
16	3443341M1	1	(A)	1	Ring, Sealing	Bague d'étanchéité	Anillo, Estanqueidad
17	1606464M1	1	(A)	1	Seal	Joint	Junta
18	1606575M1	1	(A)	1	Seal, Wiper	Joint de racleur	Junta raspador
19	3441606M91	1		1	Rod, Piston	Tige de vérin	Vástago cilindro
20	3623300M91		(B)	1	Kit, Seal	Pochette de joints	Juego de juntas

A Included in kit marked (B)
 Inclus dans jeu marqué (B)
 Incluido en juego marcado (B)

B Contains items marked (A)
 Comprend les pièces marquées (A)
 Incluye las piezas marcadas (A)



820 860 880 970 980
 TX760B TX860B

805 806 807 808 817 825 833 834 845 855 921 931

70001C03.1

6199042M3

1

Jan-06

C-70004-01.1-A

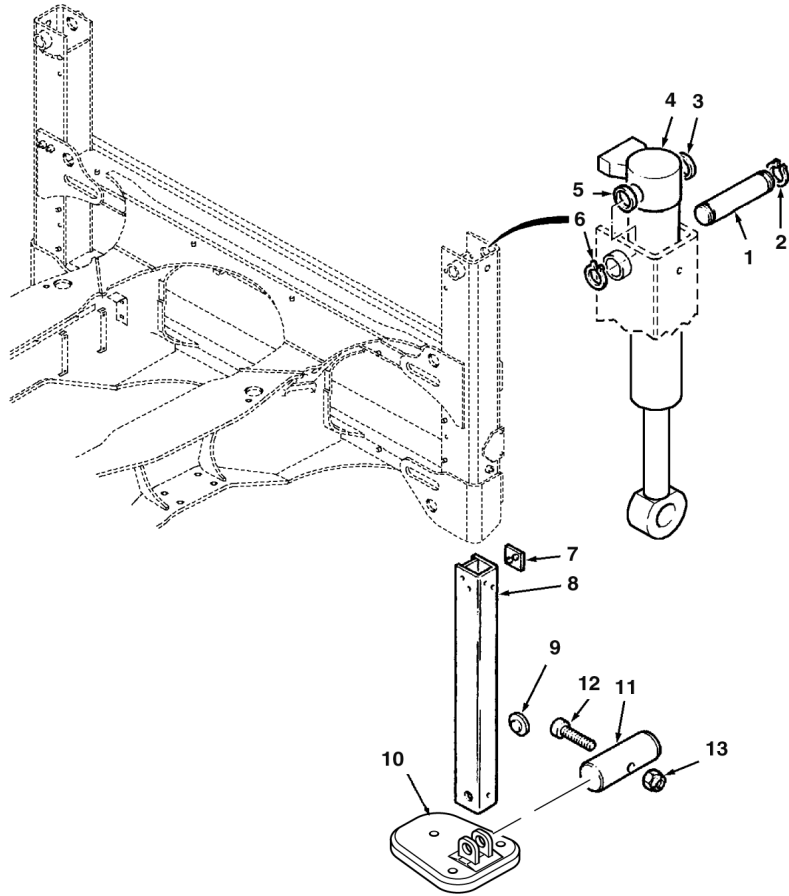

1	3521289M3	45 x 230 mm	2	Pin	Axe	Pasador
2	1440478X1		2	Ring, Snap	Anneau d'arrêt	Anillo de resorte
3	3521279M2		2	Spacer	Entretoise	Traviesa
4		<ul style="list-style-type: none"> ● 70004C02.1 1 ● 70004C03.1 1 	2	Cylinder Assy	Ensemble de vérin	Gato, Conj.
5	3521279M2		2	Spacer	Entretoise	Traviesa
6	1440478X1		2	Ring, Snap	Anneau d'arrêt	Anillo de resorte
7	6108417M1	3.6 mm Green	X	Pad, Wear	Patin d'usure	Patin de desgaste
7	6108416M1	4 mm Blue	X	Pad, Wear	Patin d'usure	Patin de desgaste
7	3516684M2	4,5 mm Yellow	X	Pad, Wear	Patin d'usure	Patin de desgaste
7	3521199M3	5,0 mm Black	X	Pad, Wear	Patin d'usure	Patin de desgaste
7	3517077M1	5,5 mm Grey	X	Pad, Wear	Patin d'usure	Patin de desgaste
7	3518965M1	6,0 mm Natural	X	Pad, Wear	Patin d'usure	Patin de desgaste
7	3518936M1	6,5 mm Red	X	Pad, Wear	Patin d'usure	Patin de desgaste
8	6108420M91	Inner	2	Stem	Tige	Varilla
9	6108419M1	3.6 mm Green	X	Pad, Wear	Patin d'usure	Patin de desgaste
9	6108418M1	4 mm Blue	X	Pad, Wear	Patin d'usure	Patin de desgaste
9	3519712M1	4,5 mm Yellow	X	Pad, Wear	Patin d'usure	Patin de desgaste
9	3519713M1	5,0 mm Black	X	Pad, Wear	Patin d'usure	Patin de desgaste
9	3519714M1	5,5 mm Grey	X	Pad, Wear	Patin d'usure	Patin de desgaste
9	3519715M1	6,0 mm Natural	X	Pad, Wear	Patin d'usure	Patin de desgaste
9	3519716M1	6,5 mm Red	X	Pad, Wear	Patin d'usure	Patin de desgaste
10	6102864M1		2	Foot	Pied	Pie
11	3522879M2	45 x 122 mm	2	Pin	Axe	Pasador
12	1442169X1	M10 x 90	2	Screw	Vis	Tornillo
13	1440329X1	M10	2	Nut, Lock	Écrou de blocage	Tuerca de retención



820 860 880 970 980
TX760B TX860B

805 806 807 808 817 825 833 834 845 855 921 931

Digger Stabilisers
Stabilisateurs
Estabilizadores

Sideshift
Montage de Pelle Latéral
Excavadora de montaje horizontal

Hydraulic Installation
Installation hydraulique
La Instalación hidráulica

C-70004-02.1-A

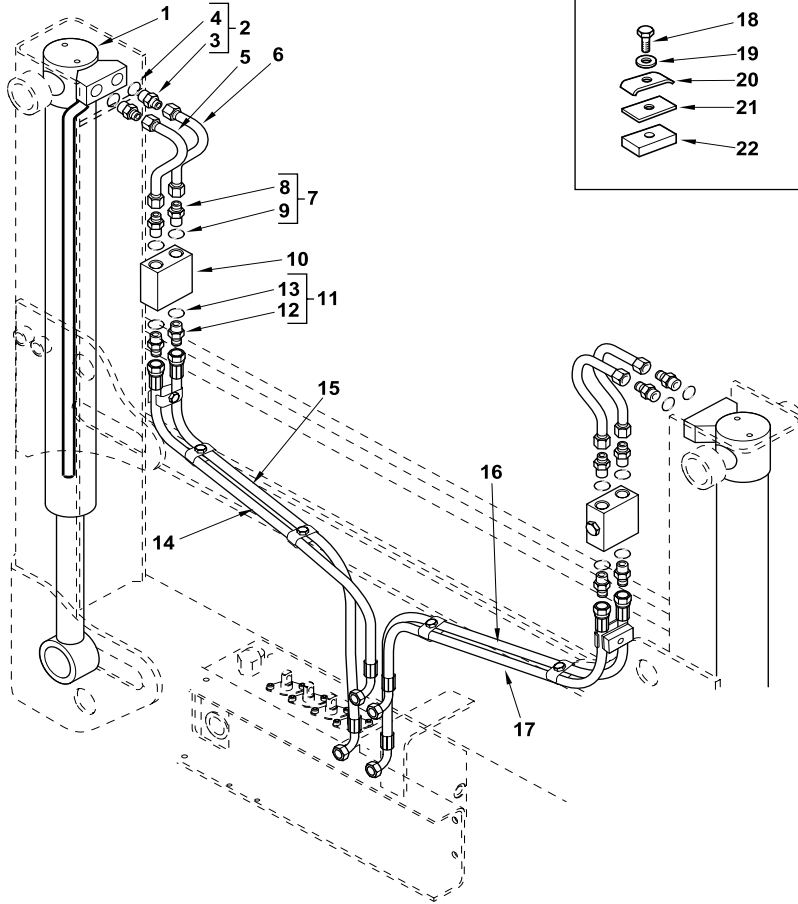

1		70004C03.1	1	2	Cylinder Assy	Ensemble de vérin	Gato, Conj.	
2	832159M91		4	4	Connector Assy	Ensemble connexion	Conexión, Conj.	
3		2	Ref. 1	1	Connector	Connecteur	Conector	
4	835024M1	2		1	O-Ring	Joint torique	Junta de tipo O	
5	6106053M91			2	Tube Assy	Tuyauterie	Conjunto de tubería	
6	6106055M91			2	Tube Assy	Tuyauterie	Conjunto de tubería	
7	3519179M91			4	Connector Assy	Ensemble connexion	Conexión, Conj.	
8		7	Ref. 7	1	Connector	Connecteur	Conector	
9	831452M1	7		1	O-Ring	Joint torique	Junta de tipo O	
10	6106226M91		70004C04.1	1	2	Valve, Lockout	Soupape verrouillage	Válvula de bloqueo.
11	3519179M91			4	Connector Assy	Ensemble connexion	Conexión, Conj.	
12		11	Ref. 11	1	Connector	Connecteur	Conector	
13	831452M1	11		1	O-Ring	Joint torique	Junta de tipo O	
14	6109762M91			1	Hose Assy	Ensemble de flexible	Flexible, Conj.	
15	6109563M91			1	Hose Assy	Ensemble de flexible	Flexible, Conj.	
16	6109564M91			1	Hose Assy	Ensemble de flexible	Flexible, Conj.	
17	6109763M91			1	Hose Assy	Ensemble de flexible	Flexible, Conj.	
18	339761X1	M8 x 25		6	Screw	Vis	Tornillo	
19	390972X1	M8		6	Washer	Rondelle	Arandela	
20	3522094M2			6	Bracket, Clamp	Bride de fixation	Brida de fijación	
21	1458385M1			6	Pad, Rubber	Plaque de caoutchouc	Placa, Caucho	
22	3518923M1			6	Spacer	Entretoise	Traviesa	



820 860 880 970 980
 TX760B TX860B

805 806 807 808 817 825 833 834 845 855 921 931

70004C02.1

6199042M3

1

Jan-06

Digger Stabilisers
Stabilisateurs
Estabilizadores

Sideshift
Montage de Pelle Latéral
Excavadora de montaje horizontal

Stabilizer Cylinder
Vérin de Stabilisateur
Gato de estabilizador

C-70004-03.1-A

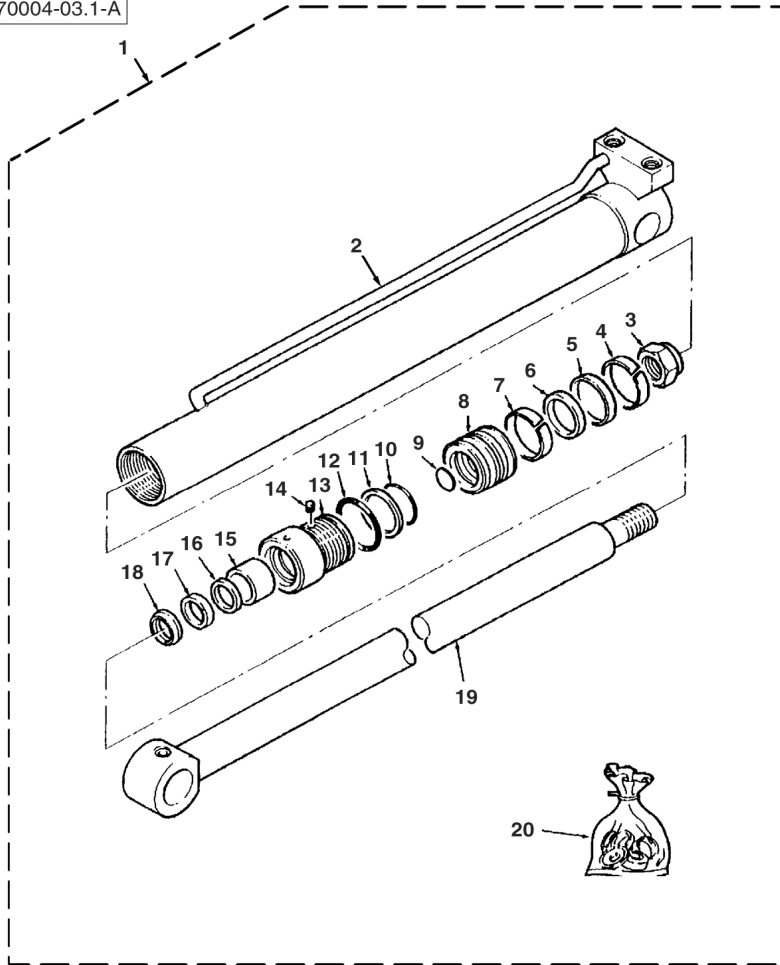

1	3622129M94		70004C01.1 1 70004C02.1 1	2	Cylinder Assy	Ensemble de vérin	Gato, Conj.
2	3623297M92	1		1	Tube, Cylinder	Cylindre de vérin	Cilindro de gato
3	1607690M1	1	M30	1	Nut	Écrou	Tuerca
4	3487067M1	1	(A)	1	Ring, Sealing	Bague d'étanchéité	Anillo, Estanqueidad
5	3485241M1	1	(A)	1	Ring	Anneau	Aro
6	3485254M1	1	(A)	1	Ring	Anneau	Aro
7	3487067M1	1		1	Ring, Sealing	Bague d'étanchéité	Anillo, Estanqueidad
8	3623299M1	1		1	Piston, Cylinder	Piston de vérin	Pistón de gato
9	359181X1	1	(A)	1	O-Ring	Joint torique	Junta de tipo O
10	359187X1	1	(A)	1	O-Ring	Joint torique	Junta de tipo O
11	1884170M1	1	(A)	1	Ring, Backup	Contre-joint	ContraJunta
12	3487205M1	1	(A)	1	O-Ring	Joint torique	Junta de tipo O
13	3623298M1	1		1	Gland, Cylinder	Palier de vérin	Palier de gato
14	3443386M1	1	(A)	1	Plug	Bouchon	Tapón
15	3491486M1	1	(A)	1	Bushing	Bague	Anillo
16	3443341M1	1	(A)	1	Ring, Sealing	Bague d'étanchéité	Anillo, Estanqueidad
17	1606464M1	1	(A)	1	Seal	Joint	Junta
18	1606575M1	1	(A)	1	Seal, Wiper	Joint de racleur	Junta raspador
19	3441606M91	1		1	Rod, Piston	Tige de vérin	Vástago cilindro
20	3623300M91		(B)	1	Kit, Seal	Pochette de joints	Juego de juntas

A Included in kit marked (B)
 Inclus dans jeu marqué (B)
 Incluido en juego marcado (B)

B Contains items marked (A)
 Comprend les pièces marquées (A)
 Incluye las piezas marcadas (A)



820 860 880 970 980
 TX760B TX860B

805 806 807 808 817 825 833 834 845 855 921 931

70004C03.1

6199042M3

1

Jan-06

Digger Stabilisers
Stabilisateurs
Estabilizadores

Sideshift
Montage de Pelle Latéral
Excavadora de montaje horizontal

Lock-out valve
Soupape verrouillage
Válvula de bloqueo.

C-70004-04.1-A

1	6106226M91	70004C02.1 10	2	Valve, Lockout	Soupape verrouillage	Válvula de bloqueo.
2		1 Ref. 1	1	Body	Corps	Cuerpo
3	6190746M91	1	1	Valve, Pilot	Soupape de pilotage	Válvula de pilotaje
4	6190747M91	1	X	Kit, Parts	Lot de pièces	Juego de piezas
5		4 Ref. 4	1	O-Ring	Joint torique	Junta de tipo O
6		4 Ref. 4	1	O-Ring	Joint torique	Junta de tipo O
7		4 Ref. 4	1	Seal	Joint	Junta
8		4 Ref. 4	1	O-Ring	Joint torique	Junta de tipo O

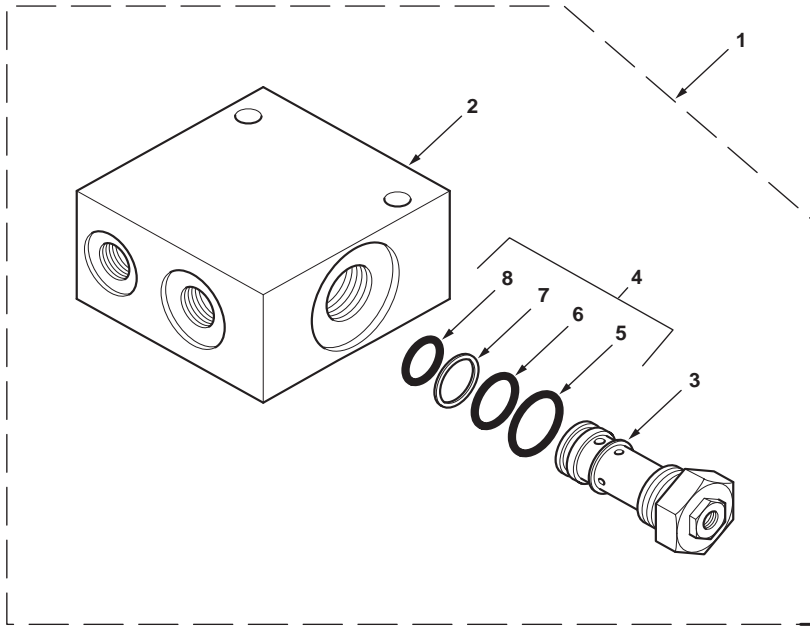

820 860 880 970 980
TX760B TX860B

805 806 807 808 817 825 833 834 845 855 921 931

70004C04.1

6199042M3

1

Jan-06

Digger Swing Pivot
Pivot d'orientation
Pivote de orientación

Centremount
Montage de Pelle Central
Excavadora de montaje central

C-71002-01.1-A

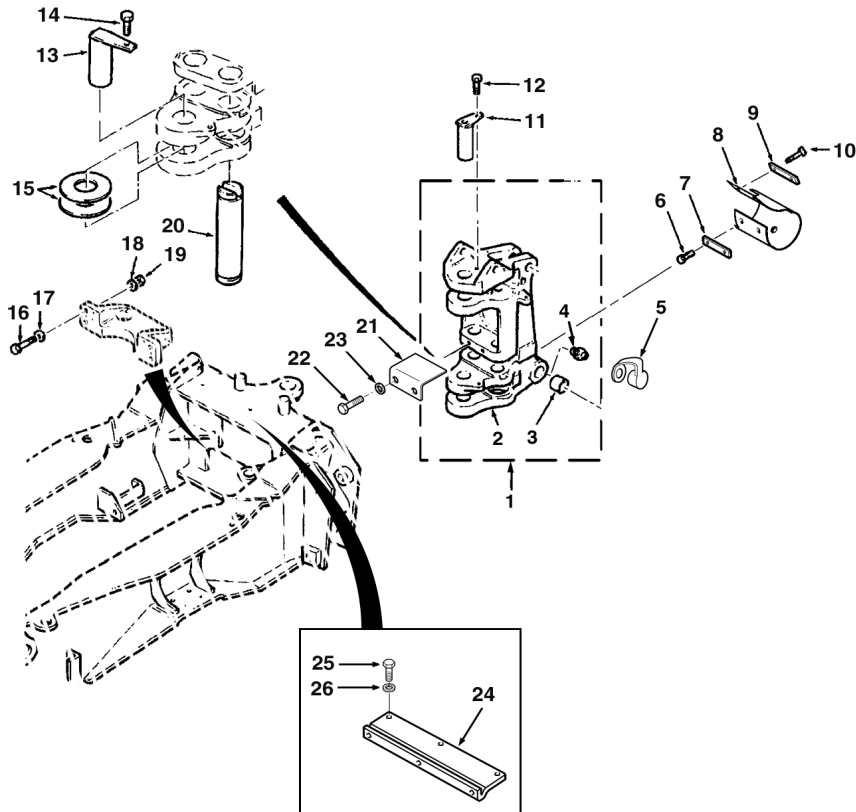

1	3517861M95		1	Pivot Assy	Ensemble de pivot	Pivote, Conj.
2		1	➡ Ref. 1	Pivot	Pivot	Pivote
3	3500047M4	1		Bushing	Bague	Anillo
4	339608X1	1		Fitting, Grease	Graisneur	Engrasador
5	3516180M2			Cover	Cache	Tapa
6	339123X1	M8 x 20		Bolt	Boulon	Perno
7	6101936M1			Plate	Plaque	Placa
8	6101935M2			Guard	Protecteur	Protector
9	6101936M1			Plate	Plaque	Placa
10	339123X1	M8 x 20		Bolt	Boulon	Perno
11	6101749M92			Pin	Axe	Pasador
12	3009492X1	M10 x 25		Screw	Vis	Tornillo
13	3521373M93	60 x 177 mm		Pin	Axe	Pasador
14	3009492X1	M10 x 25		Screw	Vis	Tornillo
15	3521389M1			Washer, Thrust	Rondelle de butée	Arandela de tope
16	3517442M1	M20 x 90		Screw	Vis	Tornillo
17	385365X1	M20		Washer	Rondelle	Arandela
18	385365X1	M20		Washer	Rondelle	Arandela
19	3522225M3	M20		Nut	Écrou	Tuerca
20	6102859M1	55 x 205 mm		Pin	Axe	Pasador
21	6102858M5			Retainer	Dispositif de retenue	Fijación
22	6007776M1	M10 x 30		Bolt	Boulon	Perno
23	385362X1	M10		Washer	Rondelle	Arandela
24	3517296M1			Plate, Cover	Plaque de fermeture	Placa de cierre
25	339124X1	M8 x 16		Screw	Vis	Tornillo
26	390972X1	M8		Washer	Rondelle	Arandela



820 860 880 970 980
TX760B TX860B
TX870B TX970B

801 802 803 804 809 810 811 812 813 814 815 816 821 822 823 824 831 832 841
842 843 844 851 852 853 854 922 923 932

71002C01.1

6199042M3

1

Jan-06

Digger Swing Pivot
Pivot d'orientation
Pivote de orientación

Centremount
Montage de Pelle Central
Excavadora de montaje central

Swing Cylinder
Vérin d'Orientation
Gato de orientación

C-71002-02.1-A

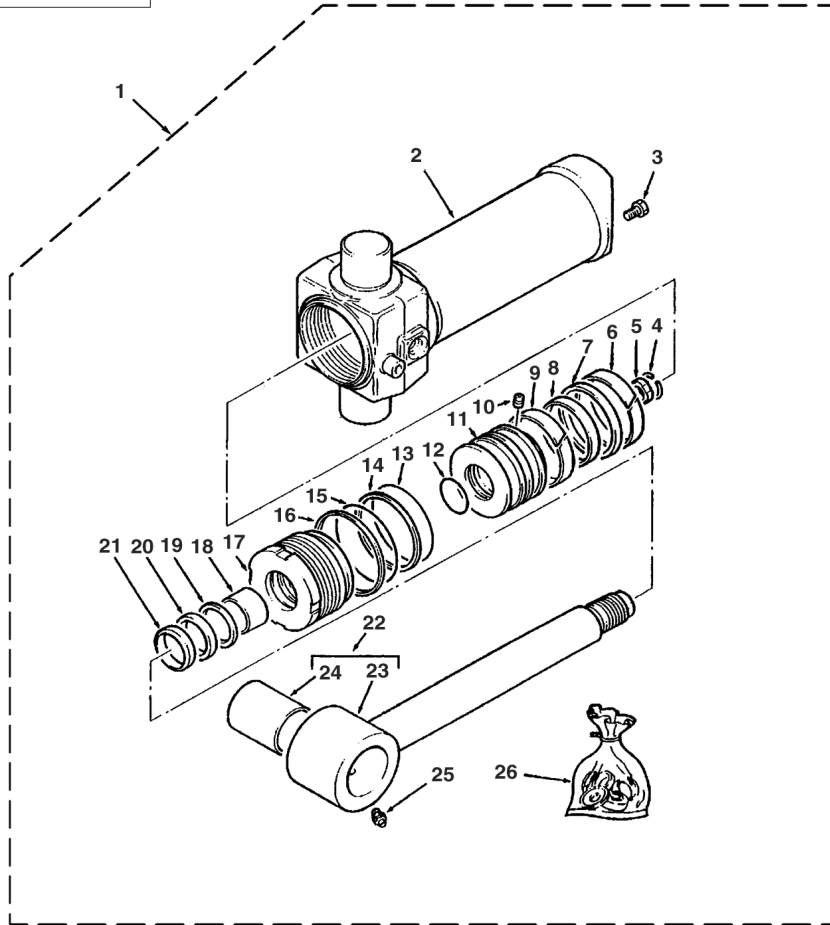

1	3622137M94		◀	1	Cylinder Assy	Ensemble de vérin	Gato, Conj.
1	3622124M94		▶	1	Cylinder Assy	Ensemble de vérin	Gato, Conj.
2	3623363M93	1	◀	1	Tube, Cylinder	Cylindre de vérin	Cilindro de gato
2	3623350M93	1	▶	1	Tube, Cylinder	Cylindre de vérin	Cilindro de gato
3	3623369M1	1		1	Plug	Bouchon	Tapón
4	3186587M1	1		1	Ring, Snap	Anneau d'arrêt	Anillo de resorte
5	3186586M1	1		1	Ring	Anneau	Aro
6	3485892M1	1	(A)	1	Ring, Sealing	Bague d'étanchéité	Anillo, Estanqueidad
7	3485245M91	1	(A)	1	Seal Assy	Ensemble de joint	Junta, Conj.
8	3485258M1	1	(A)	1	Seal	Joint	Junta
9	3485892M1	1		1	Ring, Sealing	Bague d'étanchéité	Anillo, Estanqueidad
10	3402928M1	1		1	Screw	Vis	Tornillo
11	3623361M1	1		1	Piston, Cylinder	Piston de vérin	Pistón de gato
12	377328X1	1	(A)	1	O-Ring	Joint torique	Junta de tipo O
13	359193X1	1	(A)	1	O-Ring	Joint torique	Junta de tipo O
14	1606735M1	1	(A)	1	Ring, Backup	Contre-joint	ContraJunta
15	3487207M1	1	(A)	1	O-Ring	Joint torique	Junta de tipo O
16	1608541M1	1	(A)	1	Ring, Retaining	Anneau de retenue	Anillo de retención
17	3623362M1	1		1	Gland, Cylinder	Palier de vérin	Palier de gato
18	3491486M1	1	(A)	1	Bushing	Bague	Anillo
19	3443341M1	1	(A)	1	Ring, Sealing	Bague d'étanchéité	Anillo, Estanqueidad
20	1606464M1	1	(A)	1	Seal	Joint	Junta
21	1606575M1	1	(A)	1	Seal, Wiper	Joint de racleur	Junta raspador
22	3623351M91	1		1	Rod, Piston	Tige de vérin	Vástago cilindro
23		22	➡ Ref. 22	1	Rod, Piston	Tige de vérin	Vástago cilindro
24	3623360M1	22		2	Bushing	Bague	Anillo
25	13811X	1		1	Fitting, Grease	Graisser	Engrasador
26	3623368M91		(B)	1	Kit, Seal	Pochette de joints	Juego de juntas

A Included in kit marked (B)
 Inclus dans jeu marqué (B)
 Incluido en juego marcado (B)

B Contains items marked (A)
 Comprend les pièces marquées (A)
 Incluye las piezas marcadas (A)



820 860 880 970 980
 TX760B TX860B
 TX870B TX970B

801 802 803 804 809 810 811 812 813 814 815 816 821 822 823 824 831 832 841
 842 843 844 851 852 853 854 922 923 932

71002C02.1

6199042M3

1

Jan-06

Digger Swing Pivot
Pivot d'orientation
Pivote de orientación

Sideshift
Montage de Pelle Latéral
Excavadora de montaje horizontal

C-71001-01.1-A

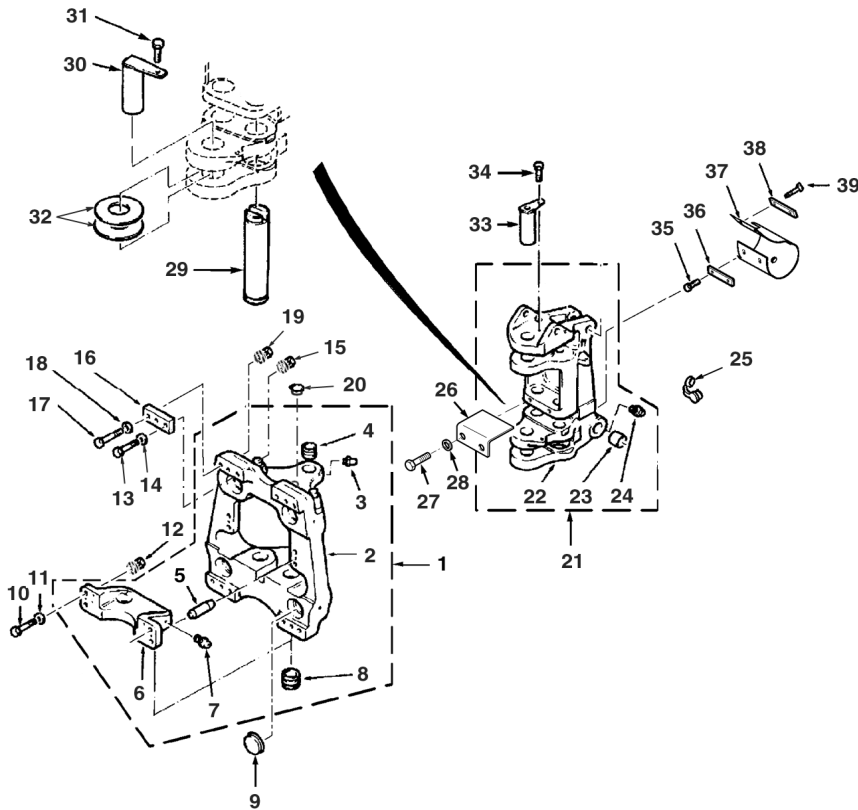

1	3518089M95		1	Frame Assy	Ensemble de bâti	Bastidor, Conj.
2		1	➡ Ref. 1	Frame	Bâti	Bastidor
3	339608X1	1		Fitting, Grease	Graisneur	Engrasador
4	3500312M3	1		Bushing	Bague	Anillo
5	3522954M1	1	12 x 55 mm	Pin, Dowel	Goupille position.	Peón
6		1	➡ Ref. 1	Mount	Support de fixation	Soporte de fijación
7	339608X1	1		Fitting, Grease	Graisneur	Engrasador
8	3521388M5	1		Bushing	Bague	Anillo
9	6110790M91			Seal Assy	Ensemble de joint	Junta, Conj.
10	3522187M2	M20 x 100		Screw	Vis	Tornillo
11	385365X1	M20		Washer	Rondelle	Arandela
12	3522225M3	M20		Nut	Écrou	Tuerca
13	3522254M2	M24 x 140		Screw	Vis	Tornillo
14	3517388M1	M24		Washer	Rondelle	Arandela
15	3522257M4	M24		Nut	Écrou	Tuerca
16	3521610M1			Plate	Plaque	Placa
17	3522255M2	M24 x 150		Screw	Vis	Tornillo
18	3517388M1	M24		Washer	Rondelle	Arandela
19	3522257M4	M24		Nut	Écrou	Tuerca
20	6008182M1	Plastic		Plug	Bouchon	Tapón
21	3517861M95			Pivot Assy	Ensemble de pivot	Pivote, Conj.
22		21	➡ Ref. 21	Pivot	Pivot	Pivote
23	3500047M4	21		Bushing	Bague	Anillo
24	339608X1	21		Fitting, Grease	Graisneur	Engrasador
25	3516180M2			Cover	Cache	Tapa
26	6102858M5			Retainer	Dispositif de retenue	Fijación
27	6007776M1	M10 x 30		Bolt	Boulon	Perno
28	385362X1	M10		Washer	Rondelle	Arandela
29	6102859M1	55 x 205 mm		Pin	Axe	Pasador
30	3521373M93	60 x 177 mm		Pin	Axe	Pasador
31	3009492X1	M10 x 25		Screw	Vis	Tornillo
32	3521389M1			Washer, Thrust	Rondelle de butée	Arandela de tope
33	6101749M92			Pin	Axe	Pasador
34	3009492X1	M10 x 25		Screw	Vis	Tornillo
35	339123X1	M8 x 20		Bolt	Boulon	Perno
36	6101936M1			Plate	Plaque	Placa
37	6101935M2			Guard	Protecteur	Protector
38	6101936M1			Plate	Plaque	Placa
39	339123X1	M8 x 20		Bolt	Boulon	Perno



820 860 880 970 980
TX760B TX860B

805 806 807 808 817 825 833 834 845 855 921 931

71001C01.1

6199042M3

1

Jan-06

Digger Swing Pivot
Pivot d'orientation
Pivote de orientación

Sideshift
Montage de Pelle Latéral
Excavadora de montaje horizontal

Swing Cylinder
Vérin d'Orientation
Gato de orientación

C-71001-02.1-A

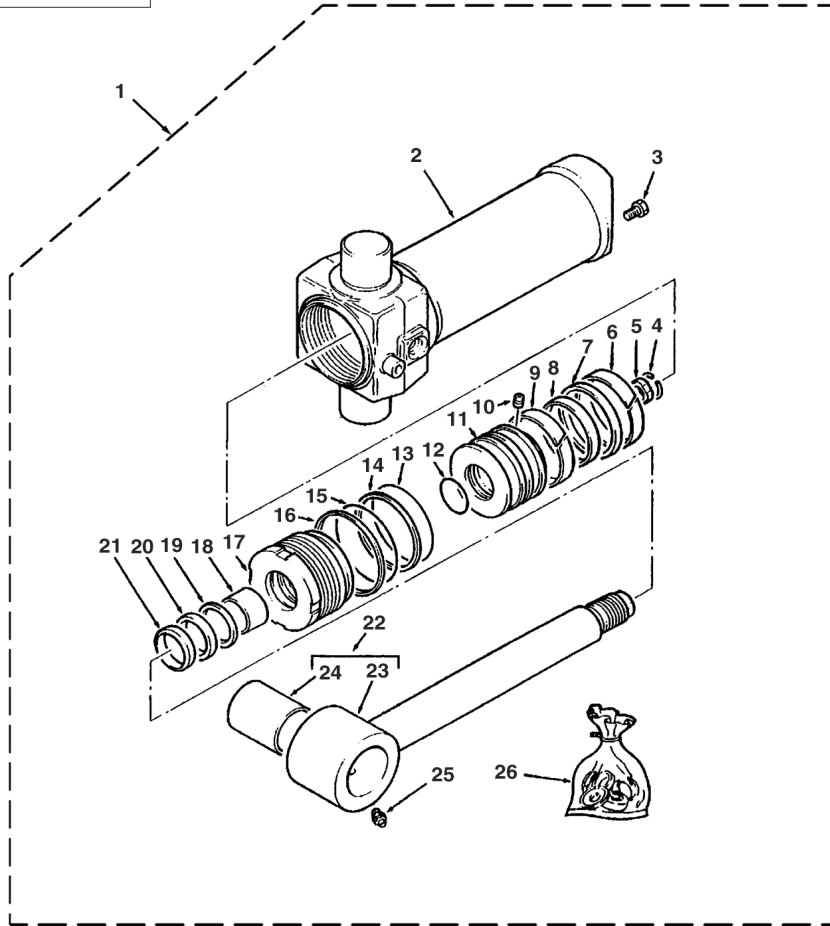

1	3622137M94		◀	1	Cylinder Assy	Ensemble de vérin	Gato, Conj.
1	3622124M94		▶	1	Cylinder Assy	Ensemble de vérin	Gato, Conj.
2	3623363M93	1	◀	1	Tube, Cylinder	Cylindre de vérin	Cilindro de gato
2	3623350M93	1	▶	1	Tube, Cylinder	Cylindre de vérin	Cilindro de gato
3	3623369M1	1		1	Plug	Bouchon	Tapón
4	3186587M1	1		1	Ring, Snap	Anneau d'arrêt	Anillo de resorte
5	3186586M1	1		1	Ring	Anneau	Aro
6	3485892M1	1	(A)	1	Ring, Sealing	Bague d'étanchéité	Anillo, Estanqueidad
7	3485245M91	1	(A)	1	Seal Assy	Ensemble de joint	Junta, Conj.
8	3485258M1	1	(A)	1	Seal	Joint	Junta
9	3485892M1	1		1	Ring, Sealing	Bague d'étanchéité	Anillo, Estanqueidad
10	3402928M1	1		1	Screw	Vis	Tornillo
11	3623361M1	1		1	Piston, Cylinder	Piston de vérin	Pistón de gato
12	377328X1	1	(A)	1	O-Ring	Joint torique	Junta de tipo O
13	359193X1	1	(A)	1	O-Ring	Joint torique	Junta de tipo O
14	1606735M1	1	(A)	1	Ring, Backup	Contre-joint	ContraJunta
15	3487207M1	1	(A)	1	O-Ring	Joint torique	Junta de tipo O
16	1608541M1	1	(A)	1	Ring, Retaining	Anneau de retenue	Anillo de retención
17	3623362M1	1		1	Gland, Cylinder	Palier de vérin	Palier de gato
18	3491486M1	1	(A)	1	Bushing	Bague	Anillo
19	3443341M1	1	(A)	1	Ring, Sealing	Bague d'étanchéité	Anillo, Estanqueidad
20	1606464M1	1	(A)	1	Seal	Joint	Junta
21	1606575M1	1	(A)	1	Seal, Wiper	Joint de racleur	Junta raspador
22	3623351M91	1		1	Rod, Piston	Tige de vérin	Vástago cilindro
23		22	➡ Ref. 22	1	Rod, Piston	Tige de vérin	Vástago cilindro
24	3623360M1	22		2	Bushing	Bague	Anillo
25	13811X	1		1	Fitting, Grease	Graisneur	Engrasador
26	3623368M91		(B)	1	Kit, Seal	Pochette de joints	Juego de juntas

A Included in kit marked (B)
 Inclus dans jeu marqué (B)
 Incluido en juego marcado (B)

B Contains items marked (A)
 Comprend les pièces marquées (A)
 Incluye las piezas marcadas (A)



820 860 880 970 980
 TX760B TX860B

805 806 807 808 817 825 833 834 845 855 921 931

71001C02.1

6199042M3

1

Jan-06

Hose Burst Kit
Coffret de Éclatement de Tuyau
Juego de rotura de tubo flexible

Boom Cylinder
 Vérin de Flèche
 Gato de pluma

4.5m
 4.5m
 4.5m

C-98039-01.1-A

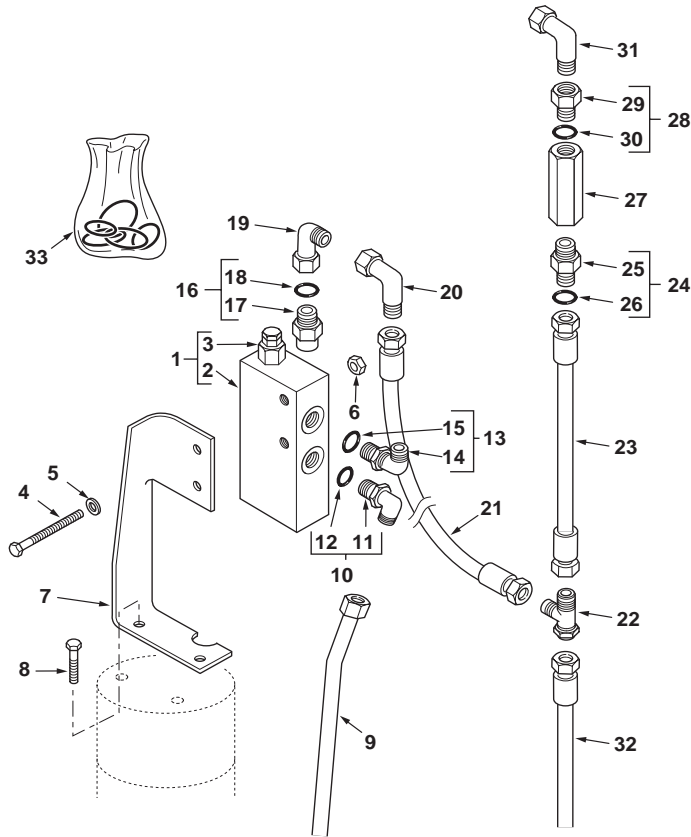

1	6109649M91		1	Valve, Lockout	Soupape verrouillage	Válvula de bloqueo.
2		1	▶ Ref. 1	1	Valve	Soupape
3	6194035M91	1	Bypass Relief	1	Cartridge Assy	Ensemble de cartouche
4	339368X1	M8 x 60		1	Bolt	Boulon
5	385361X1	M8		1	Washer	Rondelle
6	394367X1	M8		1	Nut, Lock	Écrou de blocage
7	6101960M1			1	Bracket	Patte de fixation
8	339123X1	M8 x 20		2	Bolt	Boulon
9	6101956M91			1	Tube Assy	Tuyauterie
10	835007M91			1	Elbow, 90°	Coude à 90°
11		10	▶ Ref. 10	1	Elbow	Coude
12	835024M1	10		1	O-Ring	Joint torique
13	835007M91			1	Elbow, 90°	Coude à 90°
14		13	▶ Ref. 13	1	Elbow	Coude
15	835024M1	13		1	O-Ring	Joint torique
16	835091M91	9/16		1	Union	Union
17		16	▶ Ref. 16	1	Connector	Connecteur
18	831452M1	16		1	O-Ring	Joint torique
19	364603X1	9/16		1	Elbow, 90°	Coude à 90°
20	364603X1	9/16		1	Elbow, 90°	Coude à 90°
21	6110438M91			1	Hose Assy	Ensemble de flexible
22	6102014M91			1	Tee	Raccord en T
23	6110437M91			1	Hose Assy	Ensemble de flexible
24	365715X91	1,1/16" - 7/8" UNF		1	Connector Assy	Ensemble connexion
25		24	▶ Ref. 24	1	Connector	Connecteur
26	835025M1	24		1	O-Ring	Joint torique
27	6109877M91			1	Valve, Check	Clapet anti-retour
28	6109944M91	1,1/16" - 7/8"		1	Connector Assy	Ensemble connexion
29		28	▶ Ref. 28	1	Connector	Connecteur
30		28	▶ Ref. 28	1	O-Ring	Joint torique
31	367386X1			1	Elbow, 90°	Coude à 90°
32	6101966M91			1	Hose Assy	Ensemble de flexible
33	6194034M91	Lockout Valve		1	Kit, Seal	Pochette de joints



820 860 880 970 980
 TX760B TX860B

801 802 803 804 805 806 807 808 813 814 817 821 822 825 831 832 833 834 841
 842 845 851 852 855 921 922 931

98039C01.1

6199042M3

1

Jan-06

Hose Burst Kit
Coffret de Éclatement de Tuyau
Juego de rotura de tubo flexible

Dipper Cylinder
 Vérin de Balancier
 Gato de balancín

4.5m
 4.5m
 4.5m

C-98039-02.1-A

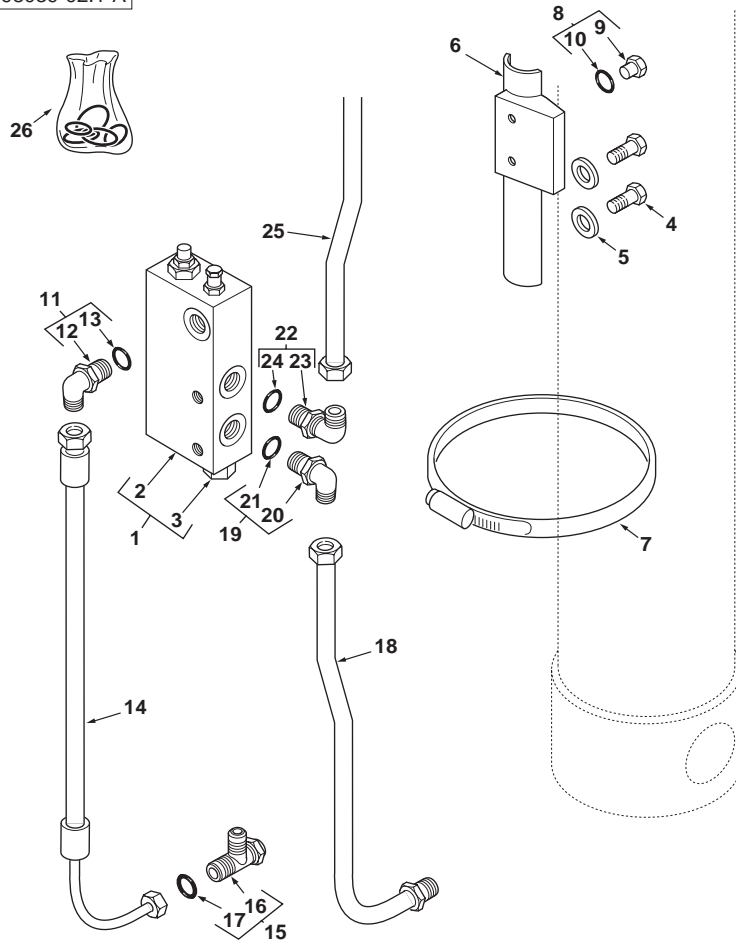

1	6109882M91		1	Valve, Lockout	Soupape verrouillage	Válvula de bloqueo.
2		1	▶ Ref. 1	1	Valve	Soupape
3	6194035M91	1	Bypass Relief	1	Cartridge Assy	Ensemble de cartouche
4	3009491X1	M10 x 20		2	Screw	Vis
5	390734X1	M10		2	Washer	Rondelle
6	6110008M91			1	Bracket Assy	Ensemble chaise palier
7	3517731M1			2	Clip, Mounting	Collier de fixation
8	373772M91	9/16		1	Plug Assy	Ensemble bouchons
9		9	▶ Ref. 9	1	Plug	Bouchon
10	831452M1	9		1	O-Ring	Joint torique
11	357197X91			1	Elbow, 90°	Coude à 90°
12		11	▶ Ref. 11	1	Elbow	Coude
13	831452M1	11		1	O-Ring	Joint torique
14	6101955M91			1	Hose Assy	Ensemble de flexible
15	6101954M91			1	Tee	Raccord en T
16		15	▶ Ref. 15	1	Tee	Raccord en T
17	835024M1	15		1	O-Ring	Joint torique
18	6110004M91			1	Tube Assy	Tuyauterie
19	835007M91			1	Elbow, 90°	Coude à 90°
20		19	▶ Ref. 19	1	Elbow	Coude
21	835024M1	19		1	O-Ring	Joint torique
22	6101624M91			1	Elbow, 90°	Coude à 90°
23		22	▶ Ref. 22	1	Elbow	Coude
24	835024M1	22		1	O-Ring	Joint torique
25	6110006M91			1	Tube Assy	Tuyauterie
26	6194036M91		Lockout Valve	X	Kit, Seal	Pochette de joints



820 860 880 970 980
 TX760B TX860B

801 802 803 804 805 806 807 808 813 814 817 821 822 825 831 832 833 834 841
 842 845 851 852 855 921 922 931

98039C02.1

6199042M3

1

Jan-06

Hose Burst Kit
Coffret de Éclatement de Tuyau
Juego de rotura de tubo flexible

Boom Cylinder
 Vérin de Flèche
 Gato de pluma

4.9m
 4.9m
 4.9m

C-98040-01.1-A

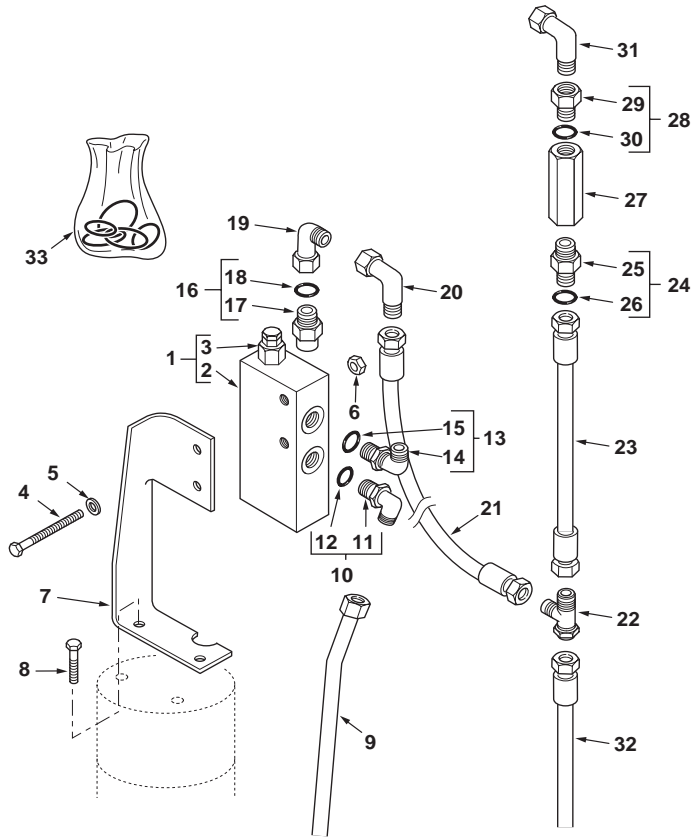

1	6109649M91		1	Valve, Lockout	Soupape verrouillage	Válvula de bloqueo.
2		1	▶ Ref. 1	1	Valve	Soupape
3	6194035M91	1	Bypass Relief	1	Cartridge Assy	Ensemble de cartouche
4	339368X1	M8 x 60		1	Bolt	Boulon
5	385361X1	M8		1	Washer	Rondelle
6	394367X1	M8		1	Nut, Lock	Écrou de blocage
7	6101960M1			1	Bracket	Patte de fixation
8	339123X1	M8 x 20		2	Bolt	Boulon
9	6102472M91			1	Tube Assy	Tuyauterie
10	835007M91			1	Elbow, 90°	Coude à 90°
11		10	▶ Ref. 10	1	Elbow	Coude
12	835024M1	10		1	O-Ring	Joint torique
13	835007M91			1	Elbow, 90°	Coude à 90°
14		13	▶ Ref. 13	1	Elbow	Coude
15	835024M1	13		1	O-Ring	Joint torique
16	835091M91	9/16		1	Union	Union
17		16	▶ Ref. 16	1	Connector	Connecteur
18	831452M1	16		1	O-Ring	Joint torique
19	364603X1	9/16		1	Elbow, 90°	Coude à 90°
20	364603X1	9/16		1	Elbow, 90°	Coude à 90°
21	6110438M91			1	Hose Assy	Ensemble de flexible
22	6102014M91			1	Tee	Raccord en T
23	6110437M91			1	Hose Assy	Ensemble de flexible
24	365715X91	1,1/16" - 7/8" UNF		1	Connector Assy	Ensemble connexion
25		24	▶ Ref. 24	1	Connector	Connecteur
26	835025M1	24		1	O-Ring	Joint torique
27	6109877M91			1	Valve, Check	Clapet anti-retour
28	6109944M91	1,1/16" - 7/8"		1	Connector Assy	Ensemble connexion
29		28	▶ Ref. 28	1	Connector	Connecteur
30		28	▶ Ref. 28	1	O-Ring	Joint torique
31	367386X1			1	Elbow, 90°	Coude à 90°
32	6101966M91			1	Hose Assy	Ensemble de flexible
33	6194034M91	Lockout Valve		1	Kit, Seal	Pochette de joints



860 880 970 980
 TX870B TX970B

815 816 823 824 843 844 853 854 923 932

98040C01.1

6199042M3

1

Jan-06

Hose Burst Kit
Coffret de Éclatement de Tuyau
Juego de rotura de tubo flexible

Dipper Cylinder
 Vérin de Balancier
 Gato de balancín

4.9m
 4.9m
 4.9m

C-98040-02.1-A

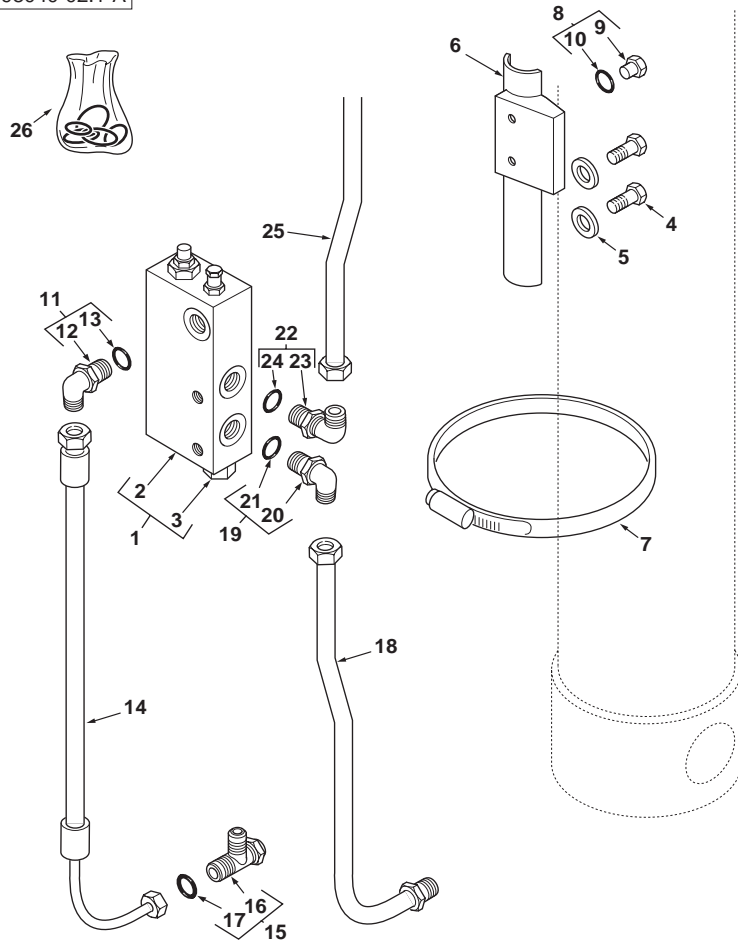

1	6109882M91		1	Valve, Lockout	Soupape verrouillage	Válvula de bloqueo.	
2		1	▶ Ref. 1	1	Valve	Soupape	Válvula
3	6194035M91	1	Bypass Relief	1	Cartridge Assy	Ensemble de cartouche	Cartucho, Conj.
4	3009491X1		M10 x 20	2	Screw	Vis	Tornillo
5	390734X1		M10	2	Washer	Rondelle	Arandela
6	6110008M91			1	Bracket Assy	Ensemble chaise palier	Cuchara, Conj.
7	3517731M1			2	Clip, Mounting	Collier de fixation	Argolla de fijación
8	373772M91		9/16	1	Plug Assy	Ensemble bouchons	Tapón, Conj.
9		9	▶ Ref. 9	1	Plug	Bouchon	Tapón
10	831452M1	9		1	O-Ring	Joint torique	Junta de tipo O
11	357197X91			1	Elbow, 90°	Coude à 90°	Codo, 90°
12		11	▶ Ref. 11	1	Elbow	Coude	Codo
13	831452M1	11		1	O-Ring	Joint torique	Junta de tipo O
14	6101955M91			1	Hose Assy	Ensemble de flexible	Flexible, Conj.
15	6101954M91			1	Tee	Raccord en T	Te
16		15	▶ Ref. 15	1	Tee	Raccord en T	Te
17	835024M1	15		1	O-Ring	Joint torique	Junta de tipo O
18	6110004M91			1	Tube Assy	Tuyauterie	Conjunto de tubería
19	835007M91			1	Elbow, 90°	Coude à 90°	Codo, 90°
20		19	▶ Ref. 19	1	Elbow	Coude	Codo
21	835024M1	19		1	O-Ring	Joint torique	Junta de tipo O
22	6101624M91			1	Elbow, 90°	Coude à 90°	Codo, 90°
23				1	Elbow	Coude	Codo
24	835024M1			1	O-Ring	Joint torique	Junta de tipo O
25	6110006M91			1	Tube Assy	Tuyauterie	Conjunto de tubería
26	6194036M91		Lockout Valve	X	Kit, Seal	Pochette de joints	Juego de juntas



860 880 970 980
 TX870B TX970B

815 816 823 824 843 844 853 854 923 932

98040C02.1

6199042M3

1

Jan-06

F - Main Hydraulics • Circuit hydraulique principal • Sistema hidráulico principal

Main Hydraulics - Hydraulic Lines 40005C01.1	Système Hydraulique - Tuyaux Hydrauliques	Sistema hidráulico - Circuito hidráulico
Main Hydraulics - Hydraulic Lines 40005C02.1	Système Hydraulique - Tuyaux Hydrauliques	Sistema hidráulico - Circuito hidráulico
Main Hydraulics - Oil Filter 40001C03.1	Système Hydraulique - Filtre à Huile	Sistema hidráulico - Filtro de aceite
Main Hydraulics - Oil Filter 40002C03.1	Système Hydraulique - Filtre à Huile	Sistema hidráulico - Filtro de aceite
Main Hydraulics - Oil Filter 40003C03.1	Système Hydraulique - Filtre à Huile	Sistema hidráulico - Filtro de aceite
Main Hydraulics - Oil Filter 40004C03.1	Système Hydraulique - Filtre à Huile	Sistema hidráulico - Filtro de aceite
Main Hydraulics - Oil Filter 40005C03.1	Système Hydraulique - Filtre à Huile	Sistema hidráulico - Filtro de aceite
Main Hydraulics - Solenoid Valve 40001C04.1	Système Hydraulique - Électrovanne	Sistema hidráulico - Electroválvula
Main Hydraulics - Solenoid Valve 40002C04.1	Système Hydraulique - Électrovanne	Sistema hidráulico - Electroválvula
Main Hydraulics - Solenoid Valve 40003C04.1	Système Hydraulique - Électrovanne	Sistema hidráulico - Electroválvula
Main Hydraulics - Solenoid Valve 40004C04.1	Système Hydraulique - Électrovanne	Sistema hidráulico - Electroválvula
Main Hydraulics - Solenoid Valve 40005C04.1	Système Hydraulique - Électrovanne	Sistema hidráulico - Electroválvula
Main Hydraulics - Tandem Pump..... 40001C06.1	Système Hydraulique - Pompe Tandem	Sistema hidráulico - Bombas enserie
Main Hydraulics - Tandem Pump..... 40002C06.1	Système Hydraulique - Pompe Tandem	Sistema hidráulico - Bombas enserie
Main Hydraulics - Tandem Pump..... 40003C06.1	Système Hydraulique - Pompe Tandem	Sistema hidráulico - Bombas enserie



Auxiliary Hydraulics
Hydraulique Auxiliaire
Circuito hidráulico auxiliar

Centremount
Montage de Pelle Central
Excavadora de montaje central

Telescopic Dipper - Boom 4.5m
Balancier Téléscopique - Flèche 4.5m
Balancín telescópico - Pluma 4.5m

Cab
 Cab
 Cab

C-80005-01.1-A

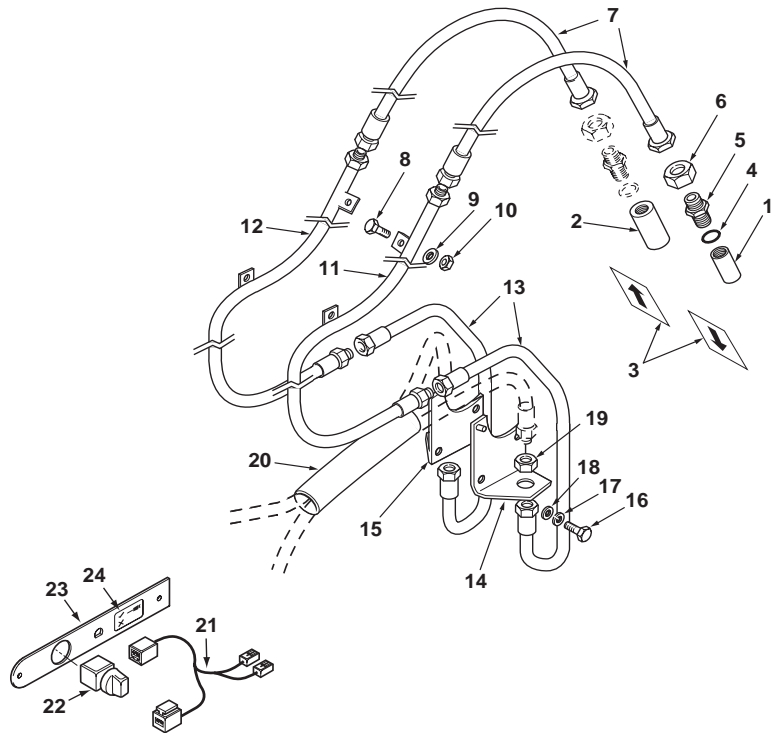

1	3516796M91	Male	1	Coupler, Quick	Coupleur rapide	Acoplador rápido
2	3516797M91	Female	1	Coupler, Quick	Coupleur rapide	Acoplador rápido
3	6106080M1	Arrow	2	Decal	Adhésif	Adhesivo
4	835025M1		2	O-Ring	Joint torique	Junta de tipo O
5	356269X1		2	Connector, Bulkhead	Passe-cloison	Pasatabiques
6	355575X1		2	Nut, Lock	Écrou de blocage	Tuerca de retención
7	6106190M91		2	Hose Assy	Ensemble de flexible	Flexible, Conj.
8	339761X1	M8 x 25	4	Screw	Vis	Tornillo
9	390972X1	M8	4	Washer	Rondelle	Arandela
10	394367X1	M8	4	Nut, Lock	Écrou de blocage	Tuerca de retención
11	6106186M91	◀	1	Tube Assy	Tuyauterie	Conjunto de tubería
12	6106188M91	▶	1	Tube Assy	Tuyauterie	Conjunto de tubería
13	6106746M91		2	Hose Assy	Ensemble de flexible	Flexible, Conj.
14	3517380M93	◀	1	Bracket Assy	Ensemble chaise palier	Cuchara, Conj.
15	3517379M2	▶	1	Bracket	Patte de fixation	Pata de fijación
16	339123X1	M8 x 20	4	Bolt	Boulon	Perno
17	339374X1	M8	4	Washer, Lock	Rondelle de blocage	Arandela de freno
18	390972X1	M8	4	Washer	Rondelle	Arandela
19	355575X1		2	Nut, Lock	Écrou de blocage	Tuerca de retención
20	6106082M1		1	Sleeve	Chemise	Camisa
21	6107467M92		1	Harness Assy	Ensemble de faisceau	Haz, Conj.
22	6107165M91		1	Switch Assy	Ensemble commutat.	Commutador, Conj.
23	6107176M2		1	Plate	Plaque	Placa
24	6108710M1		1	Decal	Adhésif	Adhesivo



820 860 880
 TX760B TX860B

801 803 809 813 821 831 841 851

80005C01.1

6199042M3

1

Jan-06

Auxiliary Hydraulics
Hydraulique Auxiliaire
Circuito hidráulico auxiliar

Centremount
Montage de Pelle Central
Excavadora de montaje central

Telescopic Dipper - Boom 4.5m
Balancier Télésopique - Flèche 4.5m
Balancín telescópico - Pluma 4.5m

Cab
 Cab
 Cab

C-80005-02.1-A

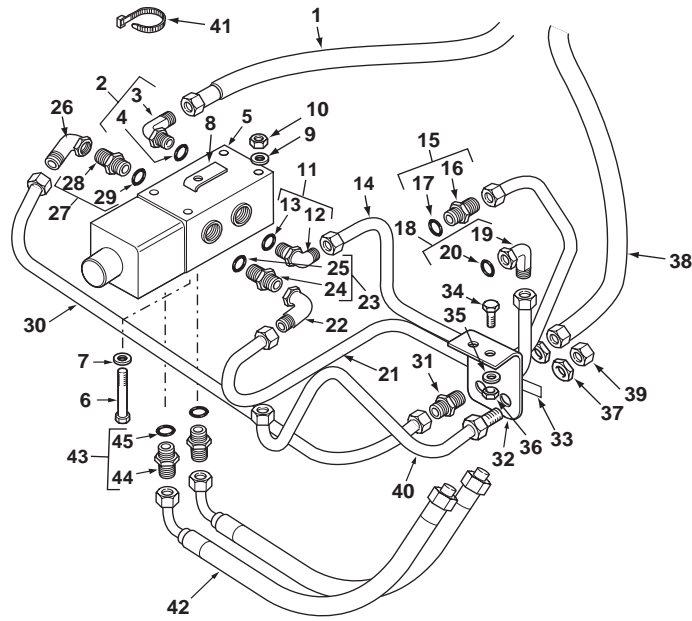

1	6107468M92		1	Hose Assy	Ensemble de flexible	Flexible, Conj.
2	358764X91		1	Elbow, 90°	Coude à 90°	Codo, 90°
3		2	1	Elbow	Coude	Codo
4	835025M1	2	1	O-Ring	Joint torique	Junta de tipo O
5	6108292M91		1	Valve, Priority	Soupape de priorité	Válvula de prioridad
6	3019894X1	M6 x 100	3	Screw	Vis	Tornillo
7	391038X1	M6	3	Washer	Rondelle	Arandela
8	6108445M1		1	Bracket	Patte de fixation	Pata de fijación
9	390971X1	M6	3	Washer	Rondelle	Arandela
10	1441500X1	M6	3	Nut, Lock	Écrou de blocage	Tuerca de retención
11	358764X91		1	Elbow, 90°	Coude à 90°	Codo, 90°
12		11	1	Elbow	Coude	Codo
13	835025M1	11	1	O-Ring	Joint torique	Junta de tipo O
14	6109620M91		1	Tube Assy	Tuyauterie	Conjunto de tubería
15	835057M91		1	Connector Assy	Ensemble connexion	Conexión, Conj.
16		15	1	Connector	Connecteur	Conector
17	835025M1	15	1	O-Ring	Joint torique	Junta de tipo O
18	358764X91		1	Elbow, 90°	Coude à 90°	Codo, 90°
19		18	1	Elbow	Coude	Codo
20	835025M1	18	1	O-Ring	Joint torique	Junta de tipo O
21	6109622M91		1	Tube Assy	Tuyauterie	Conjunto de tubería
22	366462X1		1	Elbow, 90°	Coude à 90°	Codo, 90°
23	835057M91		1	Connector Assy	Ensemble connexion	Conexión, Conj.
24		23	1	Connector	Connecteur	Conector
25	835025M1	23	1	O-Ring	Joint torique	Junta de tipo O
26	366462X1		1	Elbow, 90°	Coude à 90°	Codo, 90°
27	835057M91		1	Connector Assy	Ensemble connexion	Conexión, Conj.
28		27	1	Connector	Connecteur	Conector
29	835025M1	27	1	O-Ring	Joint torique	Junta de tipo O
30	6109766M91		1	Tube Assy	Tuyauterie	Conjunto de tubería
31	356269X1		1	Connector, Bulkhead	Passerelle	Pasatabiques
32	6109769M1		1	Bracket	Patte de fixation	Pata de fijación
33	6109770M1		1	Decal	Adhésif	Adhesivo
34	339804X1	M6 x 25	2	Screw	Vis	Tornillo
35	390971X1	M6	2	Washer	Rondelle	Arandela
36	1441500X1	M6	2	Nut, Lock	Écrou de blocage	Tuerca de retención
37	355575X1		2	Nut, Lock	Écrou de blocage	Tuerca de retención
38	6109768M91		1	Hose Assy	Ensemble de flexible	Flexible, Conj.
39	355782X1		1	Plug, Blank-Off	Obturateur	Obturador
40	6110023M91		1	Tube Assy	Tuyauterie	Conjunto de tubería
41	1862425M1		6	Tie, Cable	Attache câble	Enlace de Cable
42	6109552M91		2	Hose Assy	Ensemble de flexible	Flexible, Conj.
43	365715X91	1, 1/16" - 7/8" UNF	2	Connector Assy	Ensemble connexion	Conexión, Conj.
44		43	1	Connector	Connecteur	Conector



820 860 880
 TX760B TX860B

801 803 809 813 821 831 841 851

80005C02.1

6199042M3

1

Jan-06

Auxiliary Hydraulics
Hydraulique Auxiliaire
Circuito hidráulico auxiliar

Centremount
Montage de Pelle Central
Excavadora de montaje central

Telescopic Dipper - Boom 4.5m
 Balancier Téléscopique - Flèche 4.5m
 Balancín telescópico - Pluma 4.5m

Cab
 Cab
 Cab

C-80005-02.1-A

45	835025M1	43		1	O-Ring	Joint torique	Junta de tipo O
----	----------	----	--	---	--------	---------------	-----------------

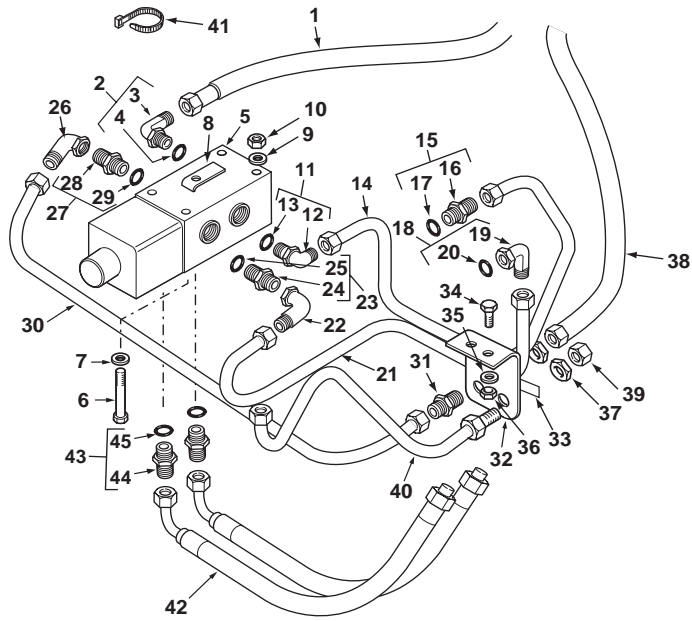

820 860 880
 TX760B TX860B

801 803 809 813 821 831 841 851

80005C02.1

6199042M3

1

Jan-06

Auxiliary Hydraulics
Hydraulique Auxiliaire
Circuito hidráulico auxiliar

Centremount
Montage de Pelle Central
Excavadora de montaje central

Telescopic Dipper - Boom 4.9m
Balancier Téléscopique - Flèche 4.9m
Balancín telescópico - Pluma 4.9m

Cab
 Cab
 Cab

C-80006-01.1-A

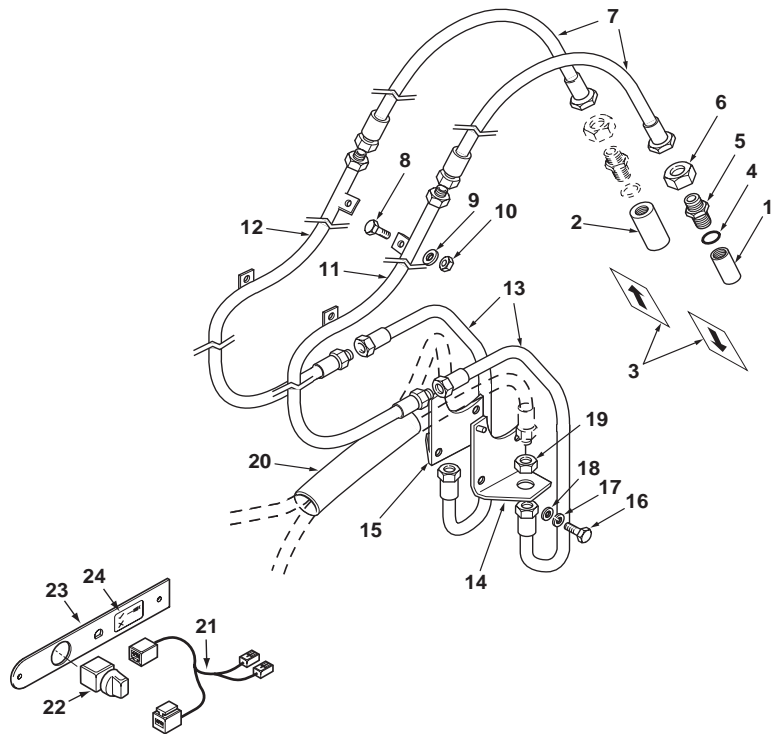

1	3516796M91	Male	1	Coupler, Quick	Coupleur rapide	Acoplador rápido
2	3516797M91	Female	1	Coupler, Quick	Coupleur rapide	Acoplador rápido
3	6106080M1	Arrow	2	Decal	Adhésif	Adhesivo
4	835025M1		2	O-Ring	Joint torique	Junta de tipo O
5	356269X1		2	Connector, Bulkhead	Passe-cloison	Pasatabiques
6	355575X1		2	Nut, Lock	Écrou de blocage	Tuerca de retención
7	6106190M91		2	Hose Assy	Ensemble de flexible	Flexible, Conj.
8	339761X1	M8 x 25	4	Screw	Vis	Tornillo
9	390972X1	M8	4	Washer	Rondelle	Arandela
10	394367X1	M8	4	Nut, Lock	Écrou de blocage	Tuerca de retención
11	6106234M91	◀	1	Tube Assy	Tuyauterie	Conjunto de tubería
12	6106236M91	▶	1	Tube Assy	Tuyauterie	Conjunto de tubería
13	6106746M91		2	Hose Assy	Ensemble de flexible	Flexible, Conj.
14	3517380M93	◀	1	Bracket Assy	Ensemble chaise palier	Cuchara, Conj.
15	3517379M2	▶	1	Bracket	Patte de fixation	Pata de fijación
16	339123X1	M8 x 20	4	Bolt	Boulon	Perno
17	339374X1	M8	4	Washer, Lock	Rondelle de blocage	Arandela de freno
18	390972X1	M8	4	Washer	Rondelle	Arandela
19	355575X1		2	Nut, Lock	Écrou de blocage	Tuerca de retención
20	6106082M1		1	Sleeve	Chemise	Camisa
21	6107467M92		1	Harness Assy	Ensemble de faisceau	Haz, Conj.
22	6107165M91		1	Switch Assy	Ensemble commutat.	Conmutador, Conj.
23	6107176M2		1	Plate	Plaque	Placa
24	6108710M1		1	Decal	Adhésif	Adhesivo



860 880
 TX870B

811 815 823 843 853

80006C01.1

6199042M3

1

Jan-06

Auxiliary Hydraulics
Hydraulique Auxiliaire
Circuito hidráulico auxiliar

Centremount
Montage de Pelle Central
Excavadora de montaje central

Telescopic Dipper - Boom 4.9m
Balancier Télésopique - Flèche 4.9m
Balancín telescópico - Pluma 4.9m

Cab
 Cab
 Cab

C-80006-02.1-A

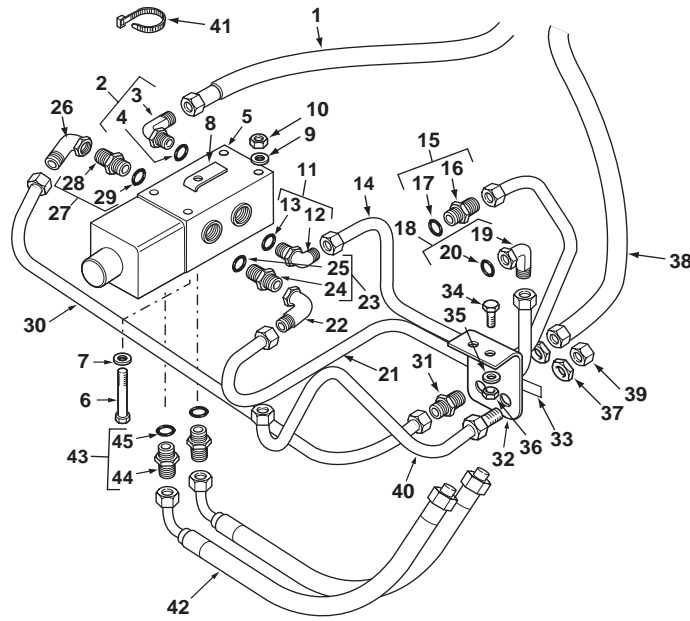

1	6107468M92		1	Hose Assy	Ensemble de flexible	Flexible, Conj.
2	358764X91		1	Elbow, 90°	Coude à 90°	Codo, 90°
3		2	Ref. 2	Elbow	Coude	Codo
4	835025M1	2		O-Ring	Joint torique	Junta de tipo O
5	6108292M91		1	Valve, Priority	Soupape de priorité	Válvula de prioridad
6	3019894X1	M6 x 100	3	Screw	Vis	Tornillo
7	391038X1	M6	3	Washer	Rondelle	Arandela
8	6108445M1		1	Bracket	Patte de fixation	Pata de fijación
9	390971X1	M6	3	Washer	Rondelle	Arandela
10	1441500X1	M6	3	Nut, Lock	Écrou de blocage	Tuerca de retención
11	358764X91		1	Elbow, 90°	Coude à 90°	Codo, 90°
12		11	Ref. 11	Elbow	Coude	Codo
13	835025M1	11		O-Ring	Joint torique	Junta de tipo O
14	6109620M91		1	Tube Assy	Tuyauterie	Conjunto de tubería
15	835057M91		1	Connector Assy	Ensemble connexion	Conexión, Conj.
16		15	Ref. 15	Connector	Connecteur	Conector
17	835025M1	15		O-Ring	Joint torique	Junta de tipo O
18	358764X91		1	Elbow, 90°	Coude à 90°	Codo, 90°
19		18	Ref. 18	Elbow	Coude	Codo
20	835025M1	18		O-Ring	Joint torique	Junta de tipo O
21	6109622M91		1	Tube Assy	Tuyauterie	Conjunto de tubería
22	366462X1		1	Elbow, 90°	Coude à 90°	Codo, 90°
23	835057M91		1	Connector Assy	Ensemble connexion	Conexión, Conj.
24		23	Ref. 23	Connector	Connecteur	Conector
25	835025M1	23		O-Ring	Joint torique	Junta de tipo O
26	366462X1		1	Elbow, 90°	Coude à 90°	Codo, 90°
27	835057M91		1	Connector Assy	Ensemble connexion	Conexión, Conj.
28		27	Ref. 27	Connector	Connecteur	Conector
29	835025M1	27		O-Ring	Joint torique	Junta de tipo O
30	6109766M91		1	Tube Assy	Tuyauterie	Conjunto de tubería
31	356269X1		1	Connector, Bulkhead	Passerelle	Pasatabiques
32	6109769M1		1	Bracket	Patte de fixation	Pata de fijación
33	6109770M1		1	Decal	Adhésif	Adhesivo
34	339804X1	M6 x 25	2	Screw	Vis	Tornillo
35	390971X1	M6	2	Washer	Rondelle	Arandela
36	1441500X1	M6	2	Nut, Lock	Écrou de blocage	Tuerca de retención
37	355575X1		2	Nut, Lock	Écrou de blocage	Tuerca de retención
38	6109768M91		1	Hose Assy	Ensemble de flexible	Flexible, Conj.
39	355782X1		1	Plug, Blank-Off	Obturateur	Obturador
40	6110023M91		1	Tube Assy	Tuyauterie	Conjunto de tubería
41	1862425M1		6	Tie, Cable	Attache câble	Enlace de Cable
42	6109552M91		2	Hose Assy	Ensemble de flexible	Flexible, Conj.
43	365715X91	1, 1/16" - 7/8" UNF	2	Connector Assy	Ensemble connexion	Conexión, Conj.
44		43	Ref. 43	Connector	Connecteur	Conector



860 880
 TX870B

811 815 823 843 853

80006C02.1

6199042M3

1

Jan-06

Auxiliary Hydraulics
Hydraulique Auxiliaire
Circuito hidráulico auxiliar

Centremount
Montage de Pelle Central
Excavadora de montaje central

Telescopic Dipper - Boom 4.9m
 Balancier Téléscopique - Flèche 4.9m
 Balancín telescópico - Pluma 4.9m

Cab
 Cab
 Cab

C-80006-02.1-A

45	835025M1	43		1	O-Ring	Joint torique	Junta de tipo O
----	----------	----	--	---	--------	---------------	-----------------

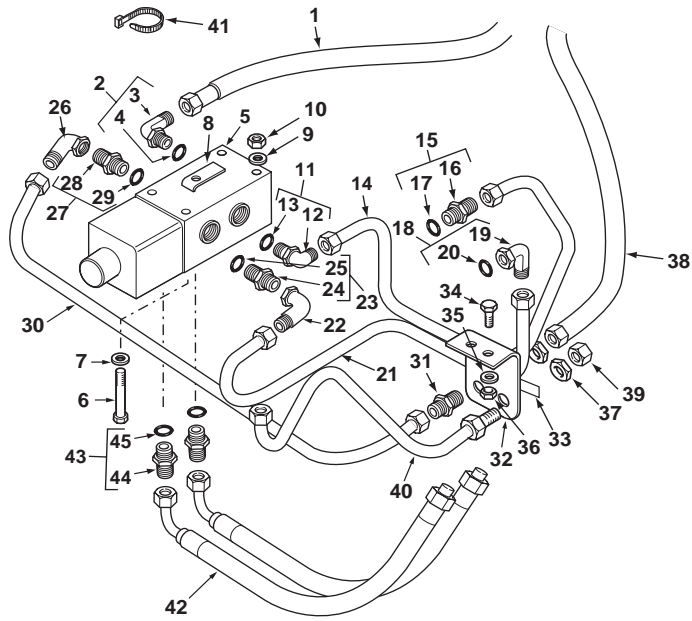

860 880
 TX870B

811 815 823 843 853

80006C02.1

6199042M3

1

Jan-06

Auxiliary Hydraulics
Hydraulique Auxiliaire
Circuito hidráulico auxiliar

Centremount
Montage de Pelle Central
Excavadora de montaje central

Telescopic Dipper - Boom 4.5m
Balancier Téléscopique - Flèche 4.5m
Balancín telescópico - Pluma 4.5m

Rops
Rops
Rops

C-80007-01.1-A

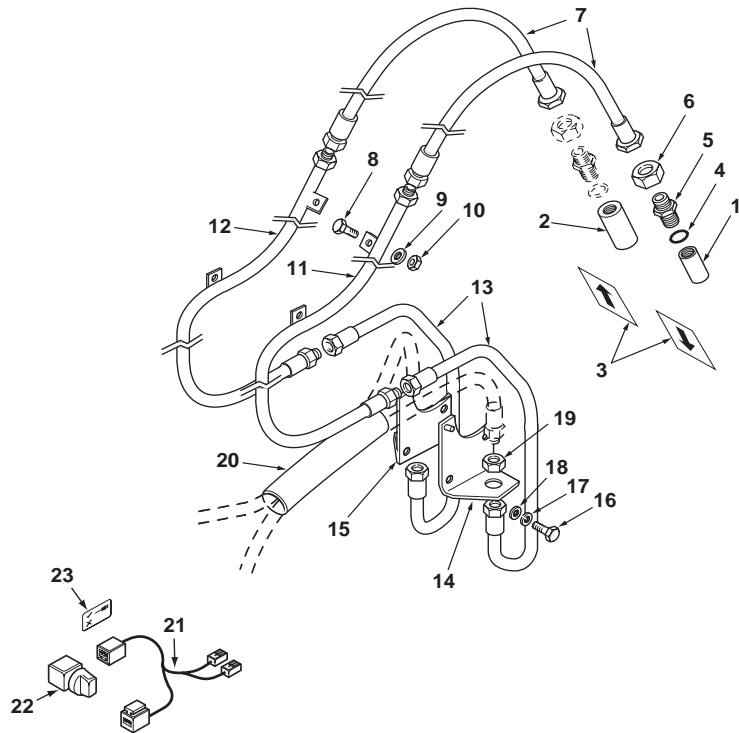

1	3516796M91	1	Male	1	Coupler, Quick	Coupleur rapide	Acoplador rápido
2	3516797M91	1	Female	1	Coupler, Quick	Coupleur rapide	Acoplador rápido
3	6106080M1	1	Arrow	2	Decal	Adhésif	Adhesivo
4	835025M1	1		2	O-Ring	Joint torique	Junta de tipo O
5	356269X1	1		2	Connector, Bulkhead	Passe-cloison	Pasatabiques
6	355575X1	1		2	Nut, Lock	Écrou de blocage	Tuerca de retención
7	6106190M91	1		2	Hose Assy	Ensemble de flexible	Flexible, Conj.
8	339761X1	1	M8 x 25	4	Screw	Vis	Tornillo
9	390972X1	1	M8	4	Washer	Rondelle	Arandela
10	394367X1	1	M8	4	Nut, Lock	Écrou de blocage	Tuerca de retención
11	6106186M91	1	◀	1	Tube Assy	Tuyauterie	Conjunto de tubería
12	6106188M91	1	▶	1	Tube Assy	Tuyauterie	Conjunto de tubería
13	6106746M91	1		2	Hose Assy	Ensemble de flexible	Flexible, Conj.
14	3517380M93	1	◀	1	Bracket Assy	Ensemble chaise palier	Cuchara, Conj.
15	3517379M2	1	▶	1	Bracket	Patte de fixation	Pata de fijación
16	339123X1	1	M8 x 20	4	Bolt	Boulon	Perno
17	339374X1	1	M8	4	Washer, Lock	Rondelle de blocage	Arandela de freno
18	390972X1	1	M8	4	Washer	Rondelle	Arandela
19	355575X1	1		2	Nut, Lock	Écrou de blocage	Tuerca de retención
20	6106082M1	1		1	Sleeve	Chemise	Camisa
21	6107467M92	1		1	Harness Assy	Ensemble de faisceau	Haz, Conj.
22	6107165M91	1		1	Switch Assy	Ensemble commutat.	Commutador, Conj.
23	6108710M1	1		1	Decal	Adhésif	Adhesivo



820 860 880
TX760B TX860B

802 804 810 814 822 832 842 852

80007C01.1

6199042M3

1

Jan-06

Auxiliary Hydraulics
Hydraulique Auxiliaire
Circuito hidráulico auxiliar

Centremount
Montage de Pelle Central
Excavadora de montaje central

Telescopic Dipper - Boom 4.5m
Balancier Télésopique - Flèche 4.5m
Balancín telescópico - Pluma 4.5m

Rops
Rops
Rops

C-80007-02.1-A

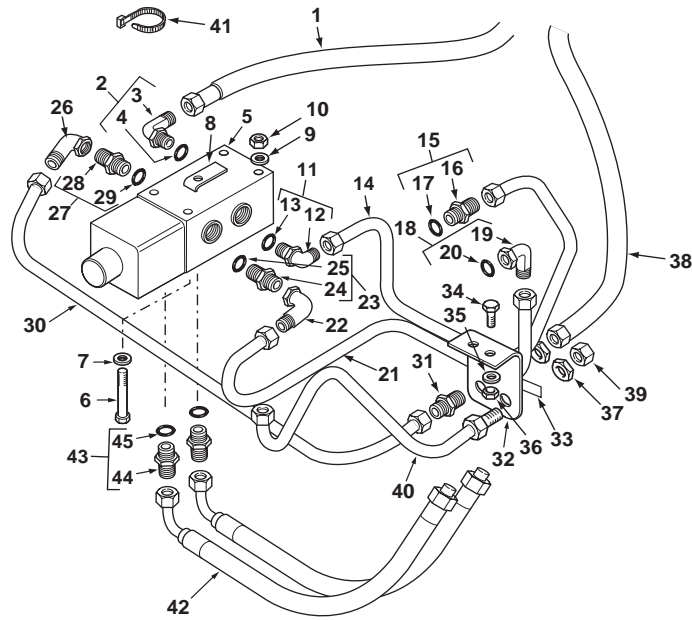

1	6107468M92		1	Hose Assy	Ensemble de flexible	Flexible, Conj.
2	358764X91		1	Elbow, 90°	Coude à 90°	Codo, 90°
3		2	Ref. 2	Elbow	Coude	Codo
4	835025M1	2		O-Ring	Joint torique	Junta de tipo O
5	6108292M91		1	Valve, Priority	Soupape de priorité	Válvula de prioridad
6	3019894X1	M6 x 100	3	Screw	Vis	Tornillo
7	391038X1	M6	3	Washer	Rondelle	Arandela
8	6108445M1		1	Bracket	Patte de fixation	Pata de fijación
9	390971X1	M6	3	Washer	Rondelle	Arandela
10	1441500X1	M6	3	Nut, Lock	Écrou de blocage	Tuerca de retención
11	358764X91		1	Elbow, 90°	Coude à 90°	Codo, 90°
12		11	Ref. 11	Elbow	Coude	Codo
13	835025M1	11		O-Ring	Joint torique	Junta de tipo O
14	6109620M91		1	Tube Assy	Tuyauterie	Conjunto de tubería
15	835057M91		1	Connector Assy	Ensemble connexion	Conexión, Conj.
16		15	Ref. 15	Connector	Connecteur	Conector
17	835025M1	15		O-Ring	Joint torique	Junta de tipo O
18	358764X91		1	Elbow, 90°	Coude à 90°	Codo, 90°
19		18	Ref. 18	Elbow	Coude	Codo
20	835025M1	18		O-Ring	Joint torique	Junta de tipo O
21	6109622M91		1	Tube Assy	Tuyauterie	Conjunto de tubería
22	366462X1		1	Elbow, 90°	Coude à 90°	Codo, 90°
23	835057M91		1	Connector Assy	Ensemble connexion	Conexión, Conj.
24		23	Ref. 23	Connector	Connecteur	Conector
25	835025M1	23		O-Ring	Joint torique	Junta de tipo O
26	366462X1		1	Elbow, 90°	Coude à 90°	Codo, 90°
27	835057M91		1	Connector Assy	Ensemble connexion	Conexión, Conj.
28		27	Ref. 27	Connector	Connecteur	Conector
29	835025M1	27		O-Ring	Joint torique	Junta de tipo O
30	6109766M91		1	Tube Assy	Tuyauterie	Conjunto de tubería
31	356269X1		1	Connector, Bulkhead	Passerelle	Pasatabiques
32	6109769M1		1	Bracket	Patte de fixation	Pata de fijación
33	6109770M1		1	Decal	Adhésif	Adhesivo
34	339804X1	M6 x 25	2	Screw	Vis	Tornillo
35	390971X1	M6	2	Washer	Rondelle	Arandela
36	1441500X1	M6	2	Nut, Lock	Écrou de blocage	Tuerca de retención
37	355575X1		2	Nut, Lock	Écrou de blocage	Tuerca de retención
38	6109768M91		1	Hose Assy	Ensemble de flexible	Flexible, Conj.
39	355782X1		1	Plug, Blank-Off	Obturateur	Obturador
40	6110023M91		1	Tube Assy	Tuyauterie	Conjunto de tubería
41	1862425M1		6	Tie, Cable	Attache câble	Enlace de Cable
42	6109552M91		2	Hose Assy	Ensemble de flexible	Flexible, Conj.
43	365715X91	1, 1/16" - 7/8" UNF	2	Connector Assy	Ensemble connexion	Conexión, Conj.
44		43	Ref. 43	Connector	Connecteur	Conector



820 860 880
TX760B TX860B

802 804 810 814 822 832 842 852

80007C02.1

6199042M3

1

Jan-06

Auxiliary Hydraulics
Hydraulique Auxiliaire
Circuito hidráulico auxiliar

Centremount
Montage de Pelle Central
Excavadora de montaje central

Telescopic Dipper - Boom 4.5m
 Balancier Téléscopique - Flèche 4.5m
 Balancín telescópico - Pluma 4.5m

Rops
 Rops
 Rops

C-80007-02.1-A

45	835025M1	43		1	O-Ring	Joint torique	Junta de tipo O
----	----------	----	--	---	--------	---------------	-----------------

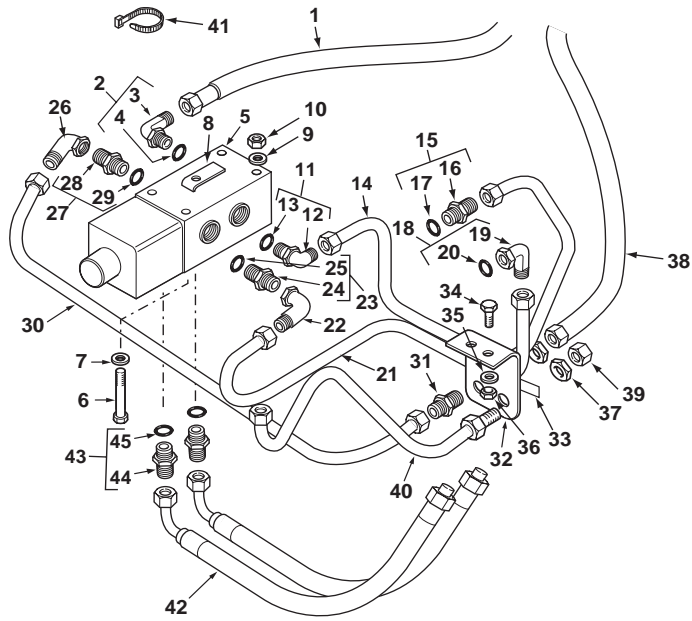

820 860 880
 TX760B TX860B

802 804 810 814 822 832 842 852

80007C02.1

6199042M3

1

Jan-06

Auxiliary Hydraulics
Hydraulique Auxiliaire
Circuito hidráulico auxiliar

Centremount
Montage de Pelle Central
Excavadora de montaje central

Telescopic Dipper - Boom 4.9m
Balancier Téléscopique - Flèche 4.9m
Balancín telescópico - Pluma 4.9m

Rops
Rops
Rops

C-80008-01.1-A

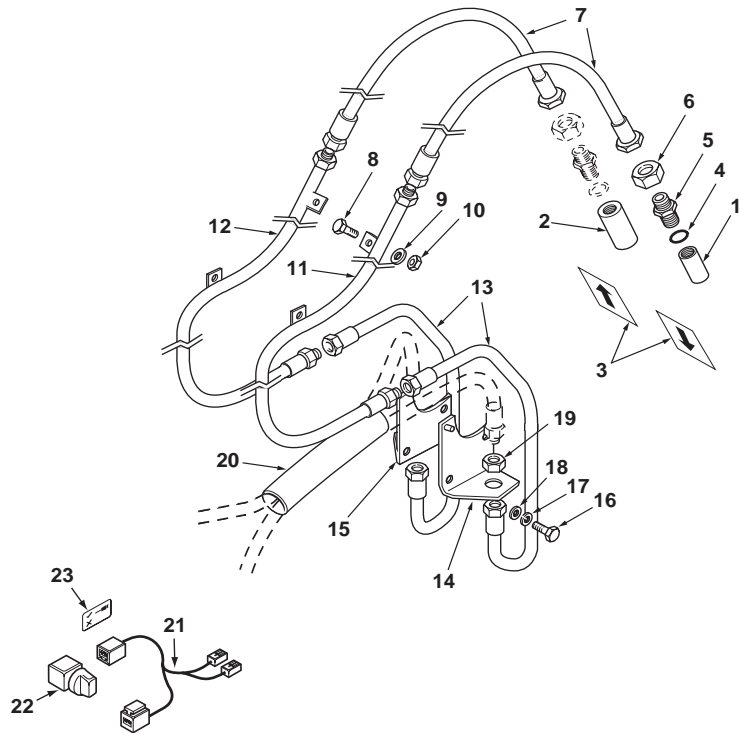

1	3516796M91	1	Male	1	Coupler, Quick	Coupleur rapide	Acoplador rápido
2	3516797M91	1	Female	1	Coupler, Quick	Coupleur rapide	Acoplador rápido
3	6106080M1	1	Arrow	2	Decal	Adhésif	Adhesivo
4	835025M1	1		2	O-Ring	Joint torique	Junta de tipo O
5	356269X1	1		2	Connector, Bulkhead	Passe-cloison	Pasatabiques
6	355575X1	1		2	Nut, Lock	Écrou de blocage	Tuerca de retención
7	6106190M91	1		2	Hose Assy	Ensemble de flexible	Flexible, Conj.
8	339761X1	1	M8 x 25	4	Screw	Vis	Tornillo
9	390972X1	1	M8	4	Washer	Rondelle	Arandela
10	394367X1	1	M8	4	Nut, Lock	Écrou de blocage	Tuerca de retención
11	6106234M91	1	◀	1	Tube Assy	Tuyauterie	Conjunto de tubería
12	6106236M91	1	▶	1	Tube Assy	Tuyauterie	Conjunto de tubería
13	6106746M91	1		2	Hose Assy	Ensemble de flexible	Flexible, Conj.
14	3517380M93	1	◀	1	Bracket Assy	Ensemble chaise palier	Cuchara, Conj.
15	3517379M2	1	▶	1	Bracket	Patte de fixation	Pata de fijación
16	339123X1	1	M8 x 20	4	Bolt	Boulon	Perno
17	339374X1	1	M8	4	Washer, Lock	Rondelle de blocage	Arandela de freno
18	390972X1	1	M8	4	Washer	Rondelle	Arandela
19	355575X1	1		2	Nut, Lock	Écrou de blocage	Tuerca de retención
20	6106082M1	1		1	Sleeve	Chemise	Camisa
21	6107467M92	1		1	Harness Assy	Ensemble de faisceau	Haz, Conj.
22	6107165M91	1		1	Switch Assy	Ensemble commutat.	Conmutador, Conj.
23	6108710M1	1		1	Decal	Adhésif	Adhesivo



860 880
TX870B

812 816 824 844 854

80008C01.1

6199042M3

1

Jan-06

Auxiliary Hydraulics
Hydraulique Auxiliaire
Circuito hidráulico auxiliar

Centremount
Montage de Pelle Central
Excavadora de montaje central

Telescopic Dipper - Boom 4.9m
Balancier Télésopique - Flèche 4.9m
Balancín telescópico - Pluma 4.9m

Rops
Rops
Rops

C-80008-02.1-A

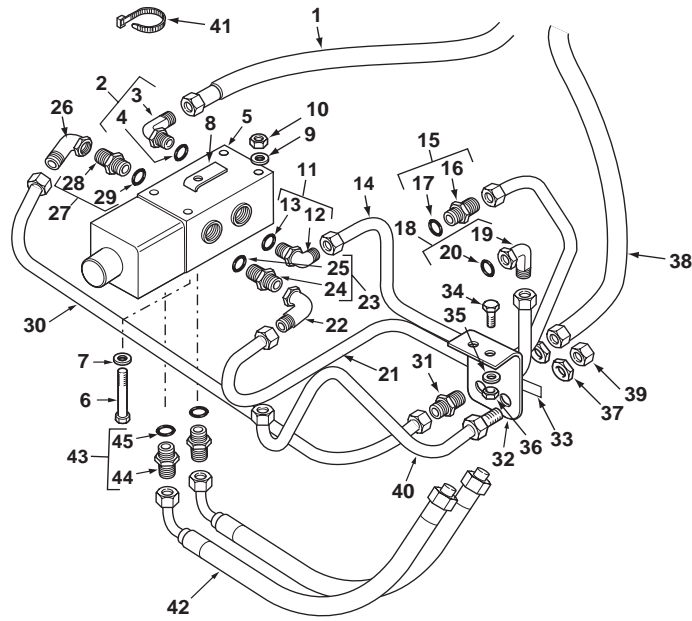

1	6107468M92		1	Hose Assy	Ensemble de flexible	Flexible, Conj.
2	358764X91		1	Elbow, 90°	Coude à 90°	Codo, 90°
3		2	Ref. 2	Elbow	Coude	Codo
4	835025M1	2		O-Ring	Joint torique	Junta de tipo O
5	6108292M91		1	Valve, Priority	Soupape de priorité	Válvula de prioridad
6	3019894X1	M6 x 100	3	Screw	Vis	Tornillo
7	391038X1	M6	3	Washer	Rondelle	Arandela
8	6108445M1		1	Bracket	Patte de fixation	Pata de fijación
9	390971X1	M6	3	Washer	Rondelle	Arandela
10	1441500X1	M6	3	Nut, Lock	Écrou de blocage	Tuerca de retención
11	358764X91		1	Elbow, 90°	Coude à 90°	Codo, 90°
12		11	Ref. 11	Elbow	Coude	Codo
13	835025M1	11		O-Ring	Joint torique	Junta de tipo O
14	6109620M91		1	Tube Assy	Tuyauterie	Conjunto de tubería
15	835057M91		1	Connector Assy	Ensemble connexion	Conexión, Conj.
16		15	Ref. 15	Connector	Connecteur	Conector
17	835025M1	15		O-Ring	Joint torique	Junta de tipo O
18	358764X91		1	Elbow, 90°	Coude à 90°	Codo, 90°
19		18	Ref. 18	Elbow	Coude	Codo
20	835025M1	18		O-Ring	Joint torique	Junta de tipo O
21	6109622M91		1	Tube Assy	Tuyauterie	Conjunto de tubería
22	366462X1		1	Elbow, 90°	Coude à 90°	Codo, 90°
23	835057M91		1	Connector Assy	Ensemble connexion	Conexión, Conj.
24		23	Ref. 23	Connector	Connecteur	Conector
25	835025M1	23		O-Ring	Joint torique	Junta de tipo O
26	366462X1		1	Elbow, 90°	Coude à 90°	Codo, 90°
27	835057M91		1	Connector Assy	Ensemble connexion	Conexión, Conj.
28		27	Ref. 27	Connector	Connecteur	Conector
29	835025M1	27		O-Ring	Joint torique	Junta de tipo O
30	6109766M91		1	Tube Assy	Tuyauterie	Conjunto de tubería
31	356269X1		1	Connector, Bulkhead	Passerelle	Pasatabiques
32	6109769M1		1	Bracket	Patte de fixation	Pata de fijación
33	6109770M1		1	Decal	Adhésif	Adhesivo
34	339804X1	M6 x 25	2	Screw	Vis	Tornillo
35	390971X1	M6	2	Washer	Rondelle	Arandela
36	1441500X1	M6	2	Nut, Lock	Écrou de blocage	Tuerca de retención
37	355575X1		2	Nut, Lock	Écrou de blocage	Tuerca de retención
38	6109768M91		1	Hose Assy	Ensemble de flexible	Flexible, Conj.
39	355782X1		1	Plug, Blank-Off	Obturateur	Obturador
40	6110023M91		1	Tube Assy	Tuyauterie	Conjunto de tubería
41	1862425M1		6	Tie, Cable	Attache câble	Enlace de Cable
42	6109552M91		2	Hose Assy	Ensemble de flexible	Flexible, Conj.
43	365715X91	1, 1/16" - 7/8" UNF	2	Connector Assy	Ensemble connexion	Conexión, Conj.
44		43	Ref. 43	Connector	Connecteur	Conector



860 880
TX870B

812 816 824 844 854

80008C02.1

6199042M3

1

Jan-06

Auxiliary Hydraulics
Hydraulique Auxiliaire
Circuito hidráulico auxiliar

Centremount
Montage de Pelle Central
Excavadora de montaje central

Telescopic Dipper - Boom 4.9m
 Balancier Téléscopique - Flèche 4.9m
 Balancín telescópico - Pluma 4.9m

Rops
 Rops
 Rops

C-80008-02.1-A

45	835025M1	43		1	O-Ring	Joint torique	Junta de tipo O
----	----------	----	--	---	--------	---------------	-----------------

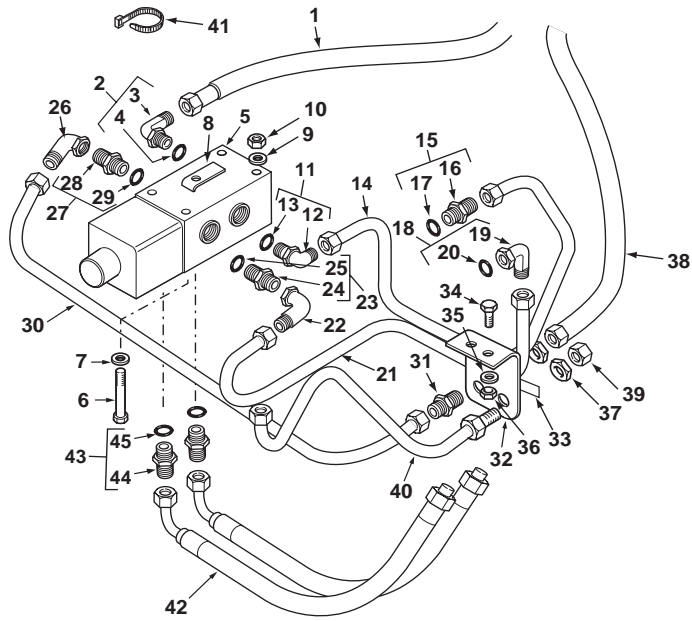

860 880
 TX870B

812 816 824 844 854

80008C02.1

6199042M3

1

Jan-06

Auxiliary Hydraulics
Hydraulique Auxiliaire
Circuito hidráulico auxiliar

Centremount
Montage de Pelle Central
Excavadora de montaje central

Telescopic Dipper - Boom 4.9m
Balancier Téléscopique - Flèche 4.9m
Balancín telescópico - Pluma 4.9m

4 Wheel Steer
 4 Wheel Steer
 4 Wheel Steer

C-80010-01.1-A

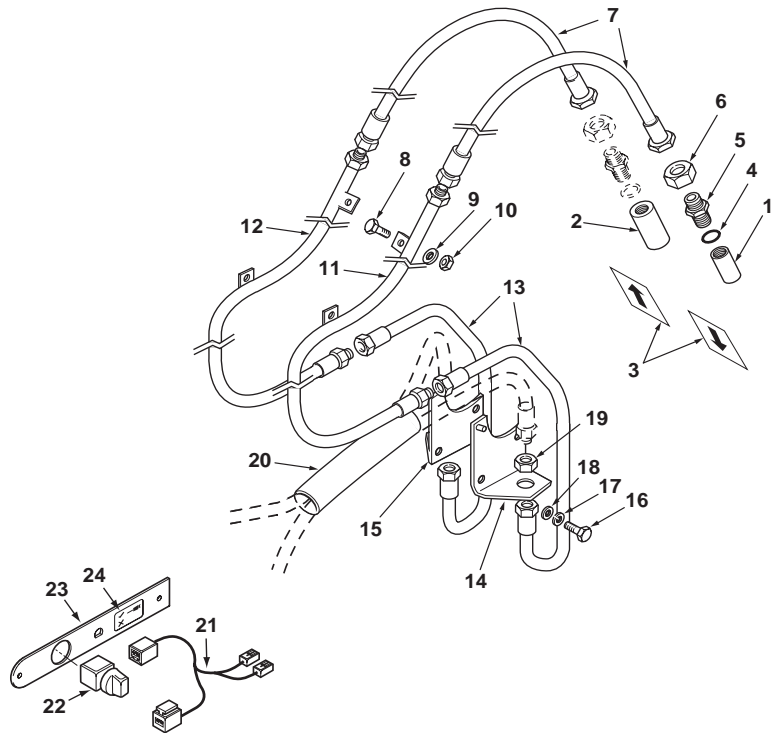

1	3516796M91	Male	1	Coupler, Quick	Coupleur rapide	Acoplador rápido
2	3516797M91	Female	1	Coupler, Quick	Coupleur rapide	Acoplador rápido
3	6106080M1	Arrow	2	Decal	Adhésif	Adhesivo
4	835025M1		2	O-Ring	Joint torique	Junta de tipo O
5	356269X1		2	Connector, Bulkhead	Passe-cloison	Pasatabiques
6	355575X1		2	Nut, Lock	Écrou de blocage	Tuerca de retención
7	6106190M91		2	Hose Assy	Ensemble de flexible	Flexible, Conj.
8	339761X1	M8 x 25	4	Screw	Vis	Tornillo
9	390972X1	M8	4	Washer	Rondelle	Arandela
10	394367X1	M8	4	Nut, Lock	Écrou de blocage	Tuerca de retención
11	6106234M91	◀	1	Tube Assy	Tuyauterie	Conjunto de tubería
12	6106236M91	▶	1	Tube Assy	Tuyauterie	Conjunto de tubería
13	6106746M91		2	Hose Assy	Ensemble de flexible	Flexible, Conj.
14	3517380M93	◀	1	Bracket Assy	Ensemble chaise palier	Cuchara, Conj.
15	3517379M2	▶	1	Bracket	Patte de fixation	Pata de fijación
16	339123X1	M8 x 20	4	Bolt	Boulon	Perno
17	339374X1	M8	4	Washer, Lock	Rondelle de blocage	Arandela de freno
18	390972X1	M8	4	Washer	Rondelle	Arandela
19	355575X1		2	Nut, Lock	Écrou de blocage	Tuerca de retención
20	6106082M1		1	Sleeve	Chemise	Camisa
21	6107467M92		1	Harness Assy	Ensemble de faisceau	Haz, Conj.
22	6107165M91		1	Switch Assy	Ensemble commutat.	Commutador, Conj.
23	6110013M1		1	Plate	Plaque	Placa
24	6109757M1		1	Decal	Adhésif	Adhesivo



970 980
 TX970B

923 932

80010C01.1

6199042M3

1

Jan-06

Auxiliary Hydraulics
Hydraulique Auxiliaire
Circuito hidráulico auxiliar

Centremount
Montage de Pelle Central
Excavadora de montaje central

Telescopic Dipper - Boom 4.9m
Balancier Télésopique - Flèche 4.9m
Balancín telescópico - Pluma 4.9m

4 Wheel Steer
 4 Wheel Steer
 4 Wheel Steer

C-80010-02.1-A

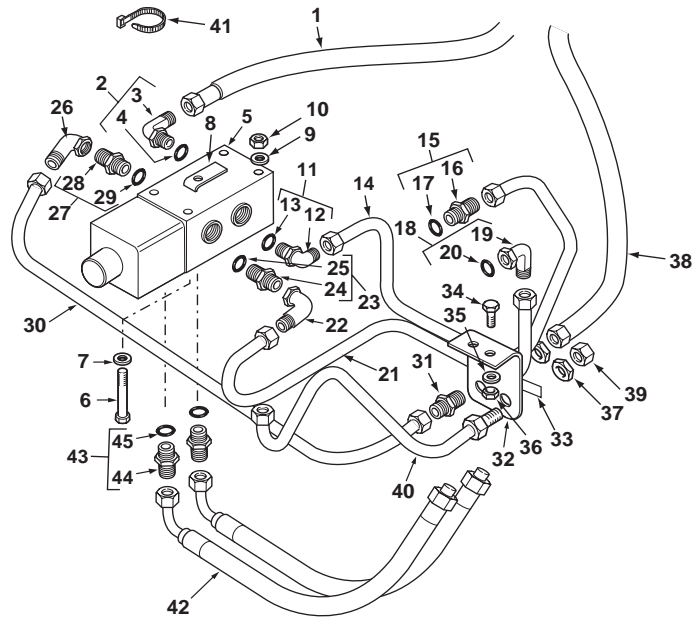

1	6107468M92		1	Hose Assy	Ensemble de flexible	Flexible, Conj.
2	358764X91		1	Elbow, 90°	Coude à 90°	Codo, 90°
3		2	Ref. 2	Elbow	Coude	Codo
4	835025M1	2	1	O-Ring	Joint torique	Junta de tipo O
5	6108292M91		1	Valve, Priority	Soupape de priorité	Válvula de prioridad
6	3019894X1	M6 x 100	3	Screw	Vis	Tornillo
7	391038X1	M6	3	Washer	Rondelle	Arandela
8	6108445M1		1	Bracket	Patte de fixation	Pata de fijación
9	390971X1	M6	3	Washer	Rondelle	Arandela
10	1441500X1	M6	3	Nut, Lock	Écrou de blocage	Tuerca de retención
11	358764X91		1	Elbow, 90°	Coude à 90°	Codo, 90°
12		11	Ref. 11	Elbow	Coude	Codo
13	835025M1	11	1	O-Ring	Joint torique	Junta de tipo O
14	6109620M91		1	Tube Assy	Tuyauterie	Conjunto de tubería
15	835057M91		1	Connector Assy	Ensemble connexion	Conexión, Conj.
16		15	Ref. 15	Connector	Connecteur	Conector
17	835025M1	15	1	O-Ring	Joint torique	Junta de tipo O
18	358764X91		1	Elbow, 90°	Coude à 90°	Codo, 90°
19		18	Ref. 18	Elbow	Coude	Codo
20	835025M1	18	1	O-Ring	Joint torique	Junta de tipo O
21	6109622M91		1	Tube Assy	Tuyauterie	Conjunto de tubería
22	366462X1		1	Elbow, 90°	Coude à 90°	Codo, 90°
23	835057M91		1	Connector Assy	Ensemble connexion	Conexión, Conj.
24		23	Ref. 23	Connector	Connecteur	Conector
25	835025M1	23	1	O-Ring	Joint torique	Junta de tipo O
26	366462X1		1	Elbow, 90°	Coude à 90°	Codo, 90°
27	835057M91		1	Connector Assy	Ensemble connexion	Conexión, Conj.
28		27	Ref. 27	Connector	Connecteur	Conector
29	835025M1	27	1	O-Ring	Joint torique	Junta de tipo O
30	6109766M91		1	Tube Assy	Tuyauterie	Conjunto de tubería
31	356269X1		1	Connector, Bulkhead	Passerelle	Pasatabiques
32	6109769M1		1	Bracket	Patte de fixation	Pata de fijación
33	6109770M1		1	Decal	Adhésif	Adhesivo
34	339804X1	M6 x 25	2	Screw	Vis	Tornillo
35	390971X1	M6	2	Washer	Rondelle	Arandela
36	1441500X1	M6	2	Nut, Lock	Écrou de blocage	Tuerca de retención
37	355575X1		2	Nut, Lock	Écrou de blocage	Tuerca de retención
38	6109768M91		1	Hose Assy	Ensemble de flexible	Flexible, Conj.
39	355782X1		1	Plug, Blank-Off	Obturateur	Obturador
40	6110023M91		1	Tube Assy	Tuyauterie	Conjunto de tubería
41	1862425M1		6	Tie, Cable	Attache câble	Enlace de Cable
42	6109552M91		2	Hose Assy	Ensemble de flexible	Flexible, Conj.
43	365715X91	1, 1/16" - 7/8" UNF	2	Connector Assy	Ensemble connexion	Conexión, Conj.
44		43	Ref. 43	Connector	Connecteur	Conector



970 980
TX970B

923 932

80010C02.1

6199042M3

1

Jan-06

Auxiliary Hydraulics
Hydraulique Auxiliaire
Circuito hidráulico auxiliar

Centremount
Montage de Pelle Central
Excavadora de montaje central

Telescopic Dipper - Boom 4.9m
 Balancier Téléscopique - Flèche 4.9m
 Balancín telescópico - Pluma 4.9m

4 Wheel Steer
 4 Wheel Steer
 4 Wheel Steer

C-80010-02.1-A

45	835025M1	43		1	O-Ring	Joint torique	Junta de tipo O
----	----------	----	--	---	--------	---------------	-----------------

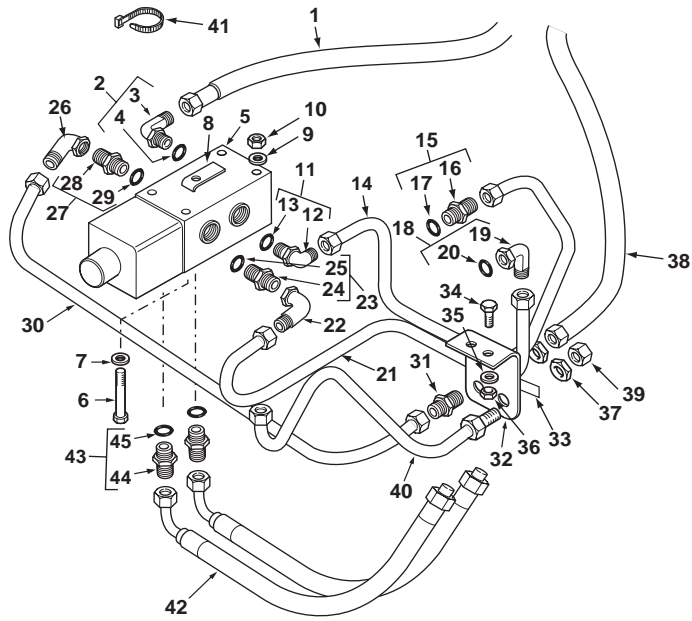

970 980
 TX970B

923 932

80010C02.1

6199042M3

1

Jan-06

Auxiliary Hydraulics
Hydraulique Auxiliaire
Circuito hidráulico auxiliar

Centremount
Montage de Pelle Central
Excavadora de montaje central

Standard Dipper
Balancier Standard
Balancín estándar

4.5m
 4.5m
 4.5m

C-80011-01.1-A

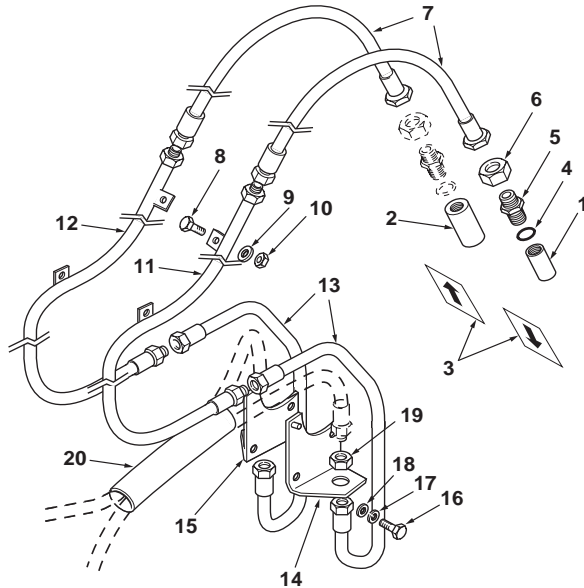

1	3516796M91	Male	1	Coupler, Quick	Coupleur rapide	Acoplador rápido
2	3516797M91	Female	1	Coupler, Quick	Coupleur rapide	Acoplador rápido
3	6106080M1	Arrow	2	Decal	Adhésif	Adhesivo
4	835025M1		2	O-Ring	Joint torique	Junta de tipo O
5	356269X1		2	Connector, Bulkhead	Passe-cloison	Pasatabiques
6	355575X1		2	Nut, Lock	Écrou de blocage	Tuerca de retención
7	6106190M91		2	Hose Assy	Ensemble de flexible	Flexible, Conj.
8	339761X1	M8 x 25	4	Screw	Vis	Tornillo
9	390972X1	M8	4	Washer	Rondelle	Arandela
10	394367X1	M8	4	Nut, Lock	Écrou de blocage	Tuerca de retención
11	6106186M91	◀	1	Tube Assy	Tuyauterie	Conjunto de tubería
12	6106188M91	▶	1	Tube Assy	Tuyauterie	Conjunto de tubería
13	6106746M91		2	Hose Assy	Ensemble de flexible	Flexible, Conj.
14	3517380M93	◀	1	Bracket Assy	Ensemble chaise palier	Cuchara, Conj.
15	3517379M2	▶	1	Bracket	Patte de fixation	Pata de fijación
16	339123X1	M8 x 20	4	Bolt	Boulon	Perno
17	339374X1	M8	4	Washer, Lock	Rondelle de blocage	Arandela de freno
18	390972X1	M8	4	Washer	Rondelle	Arandela
19	355575X1		2	Nut, Lock	Écrou de blocage	Tuerca de retención
20	6106082M1		1	Sleeve	Chemise	Camisa



820 860 880 970
 TX760B TX860B

801 802 803 804 809 810 813 814 821 822 831 832 841 842 851 852 922

80011C01.1

6199042M3

1

Jan-06

Auxiliary Hydraulics
Hydraulique Auxiliaire
Circuito hidráulico auxiliar

Centremount
Montage de Pelle Central
Excavadora de montaje central

Standard Dipper
Balancier Standard
Balancín estándar

4.5m
 4.5m
 4.5m

C-80011-02.1-A

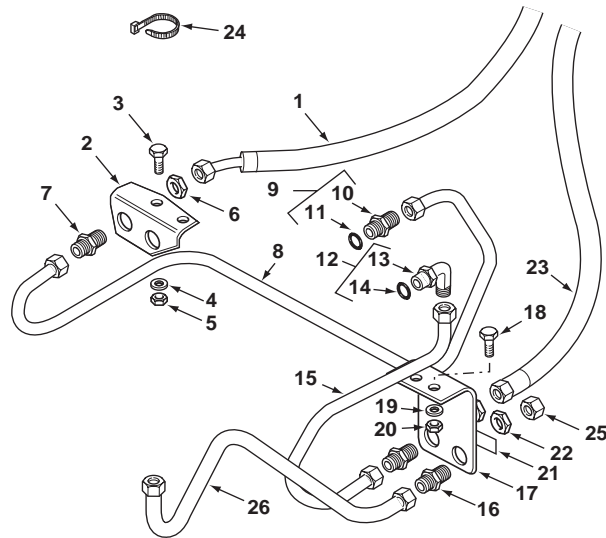

1	6107468M92		1	Hose Assy	Ensemble de flexible	Flexible, Conj.
2	6110076M1		1	Bracket	Patte de fixation	Pata de fijación
3	339804X1	M6 x 25	2	Screw	Vis	Tornillo
4	390971X1	M6	2	Washer	Rondelle	Arandela
5	1441500X1	M6	2	Nut, Lock	Écrou de blocage	Tuerca de retención
6	355575X1		1	Nut, Lock	Écrou de blocage	Tuerca de retención
7	356269X1		1	Connector, Bulkhead	Passe-cloison	Pasatabiques
8	6110077M91		1	Tube Assy	Tuyauterie	Conjunto de tubería
9	835057M91		1	Connector Assy	Ensemble connexion	Conexión, Conj.
10		9	1	Connector	Connecteur	Conector
11	835025M1	9	1	O-Ring	Joint torique	Junta de tipo O
12	358764X91		1	Elbow, 90°	Coude à 90°	Codo, 90°
13		12	1	Elbow	Coude	Codo
14	835025M1	12	1	O-Ring	Joint torique	Junta de tipo O
15	6110079M91		1	Tube Assy	Tuyauterie	Conjunto de tubería
16	356269X1		1	Connector, Bulkhead	Passe-cloison	Pasatabiques
17	6109769M1		1	Bracket	Patte de fixation	Pata de fijación
18	339804X1	M6 x 25	2	Screw	Vis	Tornillo
19	390971X1	M6	2	Washer	Rondelle	Arandela
20	1441500X1	M6	2	Nut, Lock	Écrou de blocage	Tuerca de retención
21	6109770M1		1	Decal	Adhésif	Adhesivo
22	355575X1		2	Nut, Lock	Écrou de blocage	Tuerca de retención
23	6109768M91		1	Hose Assy	Ensemble de flexible	Flexible, Conj.
24	1862425M1		6	Tie, Cable	Attache câble	Enlace de Cable
25	355782X1		1	Plug, Blank-Off	Obturateur	Obturador
26	6110023M91		1	Tube Assy	Tuyauterie	Conjunto de tubería



820 860 880 970
 TX760B TX860B

801 802 803 804 809 810 813 814 821 822 831 832 841 842 851 852 922

80011C02.1

6199042M3

1

Jan-06

Auxiliary Hydraulics
Hydraulique Auxiliaire
Circuito hidráulico auxiliar

Centremount
Montage de Pelle Central
Excavadora de montaje central

Control Pedal
Pédale de Commande
Pedal de control

C-80011-03.1-A

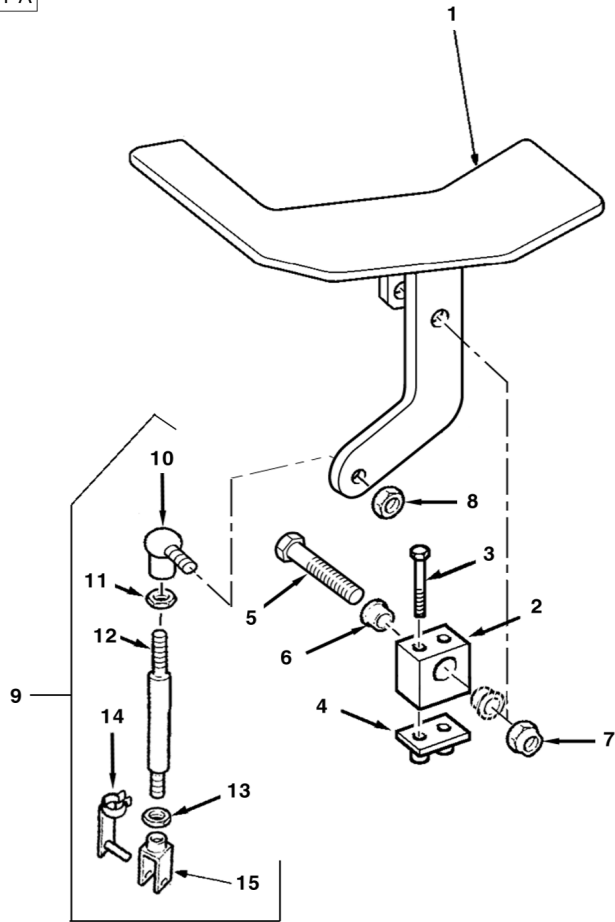

1	6106874M91		1	Pedal Assy	Ensemble de pédale	Pedal, Conj.
2	6106734M1		1	Pivot	Pivot	Pivote
3	3001758X1	M6 x 50	2	Screw	Vis	Tornillo
4	3519538M1		1	Plate, Base	Plaque de base	Placa de base
5	6106981M1	M10 x 60	1	Bolt	Boulon	Perno
6	6106866M1		2	Bushing	Bague	Anillo
7	1440329X1	M10	1	Nut, Lock	Écrou de blocage	Tuerca de retención
8	394367X1	M8	1	Nut, Lock	Écrou de blocage	Tuerca de retención
9	6106724M92		1	Rod Assy	Ensemble tringlerie	Tirantes, Conj.
10	3517518M1	9	1	Ball Joint	Rotule	Rotula
11	339169X1	9 M8	1	Nut	Écrou	Tuerca
12		9 Ref.9	1	Rod	Tringle	Vástago
13	3519650M1	9 M8 LH Thread	1	Nut	Écrou	Tuerca
14	3520666M1	9	1	Pin, Clevis	Axe de chape	Eje de brida
15	3519590M1	9 LH Thread	1	Clevis	Chape	Brida
16	6101865M2		1	Decal	Adhésif	Adhesivo



820 860 880 970
TX760B TX860B

801 802 803 804 809 810 813 814 821 822 831 832 841 842 851 852 922

80011C03.1

6199042M3

1

Jan-06

Auxiliary Hydraulics
Hydraulique Auxiliaire
Circuito hidráulico auxiliar

Centremount
Montage de Pelle Central
Excavadora de montaje central

Standard Dipper
Balancier Standard
Balancín estándar

4.9m
 4.9m
 4.9m

C-80012-01.1-A

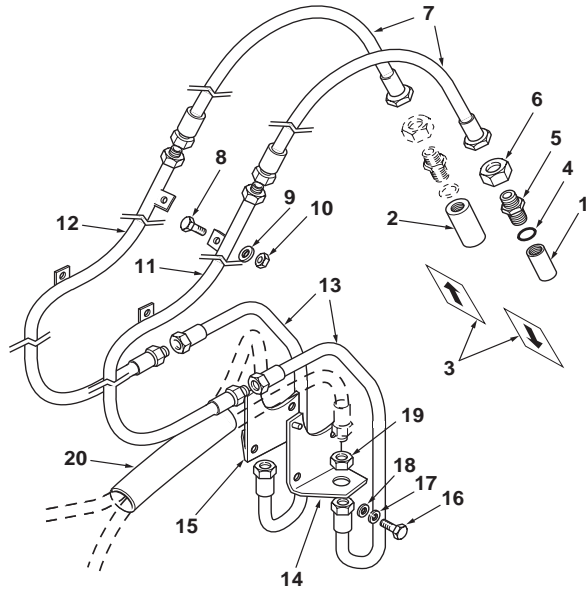

1	3516796M91	Male	1	Coupler, Quick	Coupleur rapide	Acoplador rápido
2	3516797M91	Female	1	Coupler, Quick	Coupleur rapide	Acoplador rápido
3	6106080M1	Arrow	2	Decal	Adhésif	Adhesivo
4	835025M1		2	O-Ring	Joint torique	Junta de tipo O
5	356269X1		2	Connector, Bulkhead	Passe-cloison	Pasatabiques
6	355575X1		2	Nut, Lock	Écrou de blocage	Tuerca de retención
7	6106190M91		2	Hose Assy	Ensemble de flexible	Flexible, Conj.
8	339761X1	M8 x 25	4	Screw	Vis	Tornillo
9	390972X1	M8	4	Washer	Rondelle	Arandela
10	394367X1	M8	4	Nut, Lock	Écrou de blocage	Tuerca de retención
11	6106234M91	◀	1	Tube Assy	Tuyauterie	Conjunto de tubería
12	6106236M91	▶	1	Tube Assy	Tuyauterie	Conjunto de tubería
13	6106746M91		2	Hose Assy	Ensemble de flexible	Flexible, Conj.
14	3517380M93	◀	1	Bracket Assy	Ensemble chaise palier	Cuchara, Conj.
15	3517379M2	▶	1	Bracket	Patte de fixation	Pata de fijación
16	339123X1	M8 x 20	4	Bolt	Boulon	Perno
17	339374X1	M8	4	Washer, Lock	Rondelle de blocage	Arandela de freno
18	390972X1	M8	4	Washer	Rondelle	Arandela
19	355575X1		2	Nut, Lock	Écrou de blocage	Tuerca de retención
20	6106082M1		1	Sleeve	Chemise	Camisa



860 880 970 980
 TX870B TX970B

811 812 815 816 823 824 843 844 853 854 923 932

80012C01.1

6199042M3

1

Jan-06

Auxiliary Hydraulics
Hydraulique Auxiliaire
Circuito hidráulico auxiliar

Centremount
Montage de Pelle Central
Excavadora de montaje central

Standard Dipper
Balancier Standard
Balancín estándar

4.9m
 4.9m
 4.9m

C-80012-02.1-A

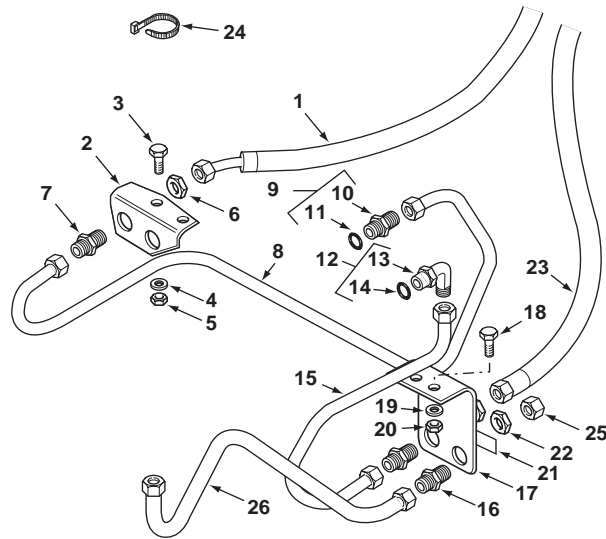

1	6107468M92		1	Hose Assy	Ensemble de flexible	Flexible, Conj.
2	6110076M1		1	Bracket	Patte de fixation	Pata de fijación
3	339804X1	M6 x 25	2	Screw	Vis	Tornillo
4	390971X1	M6	2	Washer	Rondelle	Arandela
5	1441500X1	M6	2	Nut, Lock	Écrou de blocage	Tuerca de retención
6	355575X1		1	Nut, Lock	Écrou de blocage	Tuerca de retención
7	356269X1		1	Connector, Bulkhead	Passe-cloison	Pasatabiques
8	6110077M91		1	Tube Assy	Tuyauterie	Conjunto de tubería
9	835057M91		1	Connector Assy	Ensemble connexion	Conexión, Conj.
10		9	1	Connector	Connecteur	Conector
11	835025M1	9	1	O-Ring	Joint torique	Junta de tipo O
12	358764X91		1	Elbow, 90°	Coude à 90°	Codo, 90°
13		12	1	Elbow	Coude	Codo
14	835025M1	12	1	O-Ring	Joint torique	Junta de tipo O
15	6110079M91		1	Tube Assy	Tuyauterie	Conjunto de tubería
16	356269X1		1	Connector, Bulkhead	Passe-cloison	Pasatabiques
17	6109769M1		1	Bracket	Patte de fixation	Pata de fijación
18	339804X1	M6 x 25	2	Screw	Vis	Tornillo
19	390971X1	M6	2	Washer	Rondelle	Arandela
20	1441500X1	M6	2	Nut, Lock	Écrou de blocage	Tuerca de retención
21	6109770M1		1	Decal	Adhésif	Adhesivo
22	355575X1		2	Nut, Lock	Écrou de blocage	Tuerca de retención
23	6109768M91		1	Hose Assy	Ensemble de flexible	Flexible, Conj.
24	1862425M1		6	Tie, Cable	Attache câble	Enlace de Cable
25	355782X1		1	Plug, Blank-Off	Obturateur	Obturador
26	6110023M91		1	Tube Assy	Tuyauterie	Conjunto de tubería



860 880 970 980
 TX870B TX970B

811 812 815 816 823 824 843 844 853 854 923 932

80012C02.1

6199042M3

1

Jan-06

Auxiliary Hydraulics
Hydraulique Auxiliaire
Circuito hidráulico auxiliar

Centremount
Montage de Pelle Central
Excavadora de montaje central

Control Pedal
Pédale de Commande
Pedal de control

C-80012-03.1-A

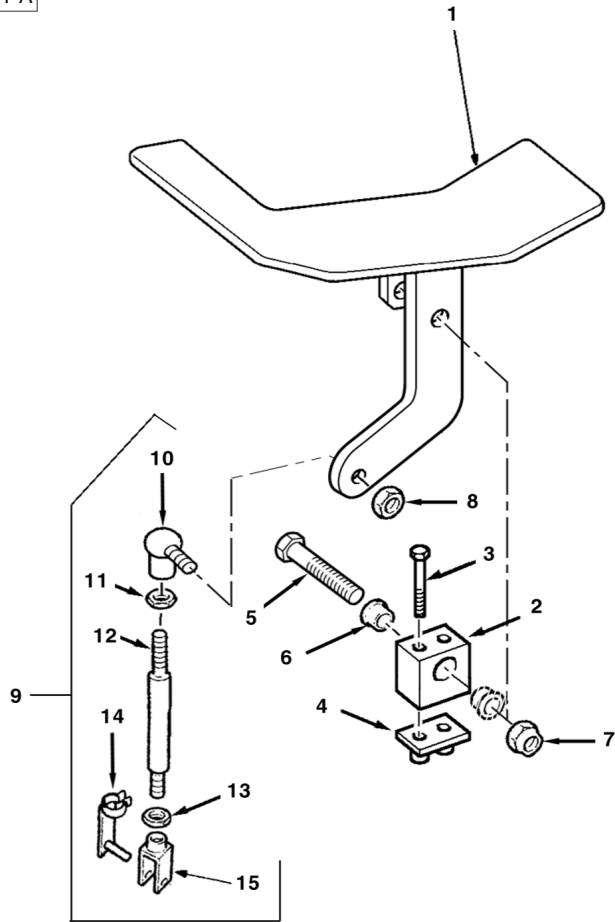

1	6106874M91		1	Pedal Assy	Ensemble de pédale	Pedal, Conj.
2	6106734M1		1	Pivot	Pivot	Pivote
3	3001758X1	M6 x 50	2	Screw	Vis	Tornillo
4	3519538M1		1	Plate, Base	Plaque de base	Placa de base
5	6106981M1	M10 x 60	1	Bolt	Boulon	Perno
6	6106866M1		2	Bushing	Bague	Anillo
7	1440329X1	M10	1	Nut, Lock	Écrou de blocage	Tuerca de retención
8	394367X1	M8	1	Nut, Lock	Écrou de blocage	Tuerca de retención
9	6106724M92		1	Rod Assy	Ensemble tringlerie	Tirantes, Conj.
10	3517518M1	9	1	Ball Joint	Rotule	Rotula
11	339169X1	9 M8	1	Nut	Écrou	Tuerca
12		9 Ref.9	1	Rod	Tringle	Vástago
13	3519650M1	9 M8 LH Thread	1	Nut	Écrou	Tuerca
14	3520666M1	9	1	Pin, Clevis	Axe de chape	Eje de brida
15	3519590M1	9 LH Thread	1	Clevis	Chape	Brida
16	6101865M2		1	Decal	Adhésif	Adhesivo



860 880 970 980
TX870B TX970B

811 812 815 816 823 824 843 844 853 854 923 932

80012C03.1

6199042M3

1

Jan-06

Auxiliary Hydraulics
Hydraulique Auxiliaire
Circuito hidráulico auxiliar

Sideshift
Montage de Pelle Latéral
Excavadora de montaje horizontal

Telescopic Dipper
Balancier Téléscopique
Balancín telescópico

C-80001-01.1-A

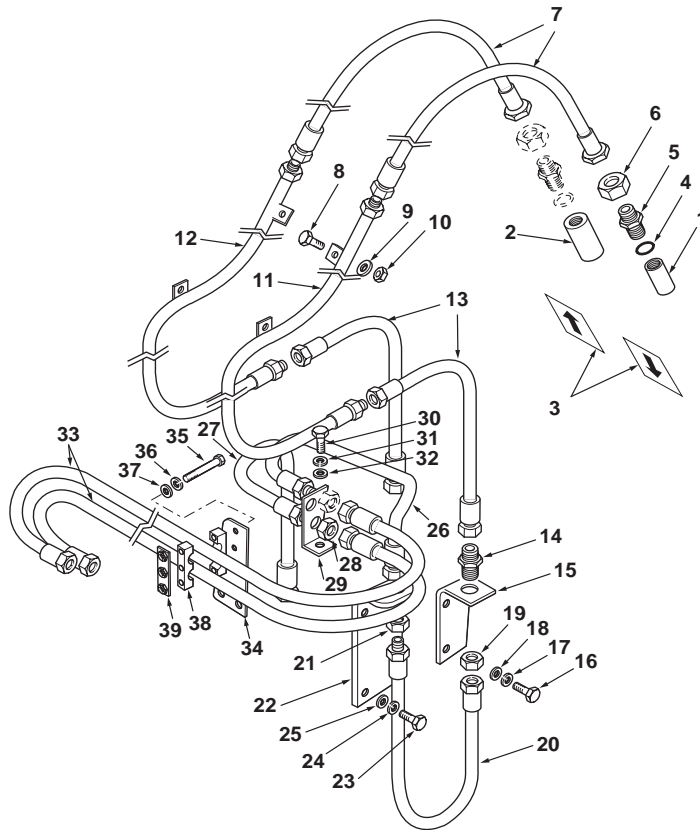

1	3516796M91	Male	1	Coupler, Quick	Coupleur rapide	Acoplador rápido
2	3516797M91	Female	1	Coupler, Quick	Coupleur rapide	Acoplador rápido
3	6106080M1	Arrow	2	Decal	Adhésif	Adhesivo
4	835025M1		2	O-Ring	Joint torique	Junta de tipo O
5	356269X1		2	Connector, Bulkhead	Passe-cloison	Pasatabiques
6	355575X1		2	Nut, Lock	Écrou de blocage	Tuerca de retención
7	6106190M91		2	Hose Assy	Ensemble de flexible	Flexible, Conj.
8	339761X1	M8 x 25	4	Screw	Vis	Tornillo
9	390972X1	M8	4	Washer	Rondelle	Arandela
10	394367X1	M8	4	Nut, Lock	Écrou de blocage	Tuerca de retención
11	6106186M91	◀	1	Tube Assy	Tuyauterie	Conjunto de tubería
12	6106188M91	▶	1	Tube Assy	Tuyauterie	Conjunto de tubería
13	6106185M91		2	Hose Assy	Ensemble de flexible	Flexible, Conj.
14	356269X1		2	Connector, Bulkhead	Passe-cloison	Pasatabiques
15	6101964M1	◀	1	Bracket	Patte de fixation	Pata de fijación
15	6101965M1	▶	1	Bracket	Patte de fixation	Pata de fijación
16	339123X1	M8 x 20	4	Bolt	Boulon	Perno
17	339374X1	M8	4	Washer, Lock	Rondelle de blocage	Arandela de freno
18	390972X1	M8	4	Washer	Rondelle	Arandela
19	355575X1		2	Nut, Lock	Écrou de blocage	Tuerca de retención
20	6101899M91		2	Hose Assy	Ensemble de flexible	Flexible, Conj.
21	355575X1		2	Nut, Lock	Écrou de blocage	Tuerca de retención
22	6101459M91		2	Bracket	Patte de fixation	Pata de fijación
23	339123X1	M8 x 20	4	Bolt	Boulon	Perno
24	339374X1	M8	4	Washer, Lock	Rondelle de blocage	Arandela de freno
25	390972X1	M8	4	Washer	Rondelle	Arandela
26	6101461M92		1	Tube Assy	Tuyauterie	Conjunto de tubería
27	6101463M92		1	Tube Assy	Tuyauterie	Conjunto de tubería
28	355575X1		2	Nut, Lock	Écrou de blocage	Tuerca de retención
29	6101466M3		1	Bracket	Patte de fixation	Pata de fijación
30	3009493X1	M10 x 30	1	Bolt	Boulon	Perno
31	339376X1	M10	1	Washer, Lock	Rondelle de blocage	Arandela de freno
32	390734X1	M10	1	Washer	Rondelle	Arandela
33	6101898M91		2	Hose Assy	Ensemble de flexible	Flexible, Conj.
34	6102026M1		1	Plate	Plaque	Placa
35	339891X1	M8 x 80	3	Screw	Vis	Tornillo
36	339374X1	M8	3	Washer, Lock	Rondelle de blocage	Arandela de freno
37	390972X1	M8	3	Washer	Rondelle	Arandela
38	3522055M3		2	Bracket, Clamp	Bride de fixation	Brida de fijación
39	6102132M91		1	Plate	Plaque	Placa



820 860 880
 TX760B TX860B

805 807 817 825 831 833 845

80001C01.1

6199042M3

1

Jan-06

Auxiliary Hydraulics
Hydraulique Auxiliaire
Circuito hidráulico auxiliar

Sideshift
Montage de Pelle Latéral
Excavadora de montaje horizontal

Telescopic Dipper
Balancier Téléscopique
Balancín telescópico

C-80001-02.1-A

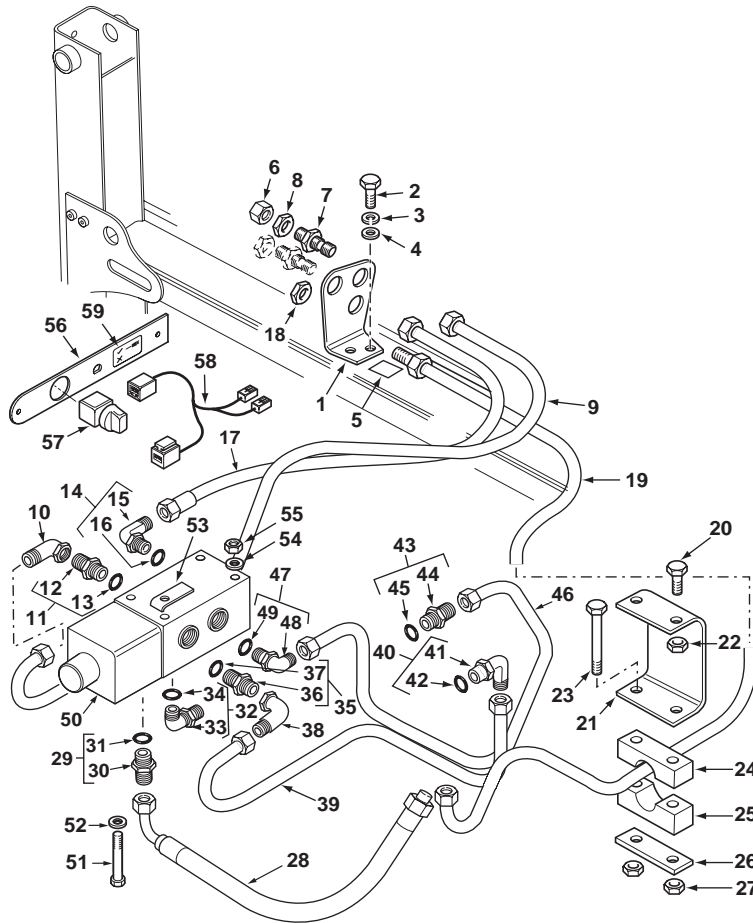

1	6109873M1		1	Bracket	Patte de fixation	Pata de fijación
2	3009491X1	M10 x 20	2	Screw	Vis	Tornillo
3	339376X1	M10	2	Washer, Lock	Rondelle de blocage	Arandela de freno
4	390734X1	M10	2	Washer	Rondelle	Arandela
5	6109756M1		1	Decal	Adhésif	Adhesivo
6	355782X1		1	Plug, Blank-Off	Obturateur	Obturador
7	356269X1		2	Connector, Bulkhead	Passe-cloison	Pasatabiques
8	355575X1		2	Nut, Lock	Écrou de blocage	Tuerca de retención
9	6109746M92		1	Tube Assy	Tuyauterie	Conjunto de tubería
10	366462X1		1	Elbow, 90°	Coude à 90°	Codo, 90°
11	835057M91		1	Connector Assy	Ensemble connexion	Conexión, Conj.
12		11	1	Connector	Connecteur	Conector
13	835025M1	11	1	O-Ring	Joint torique	Junta de tipo O
14	358764X91		1	Elbow, 90°	Coude à 90°	Codo, 90°
15		14	1	Elbow	Coude	Codo
16	835025M1	14	1	O-Ring	Joint torique	Junta de tipo O
17	6107408M93		1	Tube Assy	Tuyauterie	Conjunto de tubería
18	355575X1		1	Nut, Lock	Écrou de blocage	Tuerca de retención
19	6109846M91		1	Tube Assy	Tuyauterie	Conjunto de tubería
20	339666X1	M6 x 20	2	Screw	Vis	Tornillo
21	6109926M1		1	Bracket	Patte de fixation	Pata de fijación
22	1441500X1	M6	2	Nut, Lock	Écrou de blocage	Tuerca de retención
23	1440922X1	M6 x 60	2	Screw	Vis	Tornillo
24	3520340M3		1	Clamp	Collier de serrage	Argolla de cierre
25	1462584M1		1	Clamp	Collier de serrage	Argolla de cierre
26	1462583M1		1	Plate	Plaque	Placa
27	1441500X1	M6	2	Nut, Lock	Écrou de blocage	Tuerca de retención
28	6108513M91		1	Hose Assy	Ensemble de flexible	Flexible, Conj.
29	365715X91	1,1/16" - 7/8" UNF	1	Connector Assy	Ensemble connexion	Conexión, Conj.
30		29	1	Connector	Connecteur	Conector
31	835025M1	29	1	O-Ring	Joint torique	Junta de tipo O
32	368113X91		1	Elbow, 90°	Coude à 90°	Codo, 90°
33		32	1	Elbow	Coude	Codo
34	835025M1	32	1	O-Ring	Joint torique	Junta de tipo O
35	835057M91		1	Connector Assy	Ensemble connexion	Conexión, Conj.
36		36	1	Connector	Connecteur	Conector
37	835025M1	36	1	O-Ring	Joint torique	Junta de tipo O
38	366462X1		1	Elbow, 90°	Coude à 90°	Codo, 90°
39	6109622M91		1	Tube Assy	Tuyauterie	Conjunto de tubería
40	358764X91		1	Elbow, 90°	Coude à 90°	Codo, 90°
41		40	1	Elbow	Coude	Codo
42	835025M1	40	1	O-Ring	Joint torique	Junta de tipo O
43	835057M91		1	Connector Assy	Ensemble connexion	Conexión, Conj.
44		43	1	Connector	Connecteur	Conector



820 860 880
 TX760B TX860B

805 807 817 825 831 833 845

80001C02.1

6199042M3

1

Jan-06

Auxiliary Hydraulics
Hydraulique Auxiliaire
Circuito hidráulico auxiliar

Sideshift
Montage de Pelle Latéral
Excavadora de montaje horizontal

Telescopic Dipper
Balancier Téléscopique
Balancín telescópico

C-80001-02.1-A

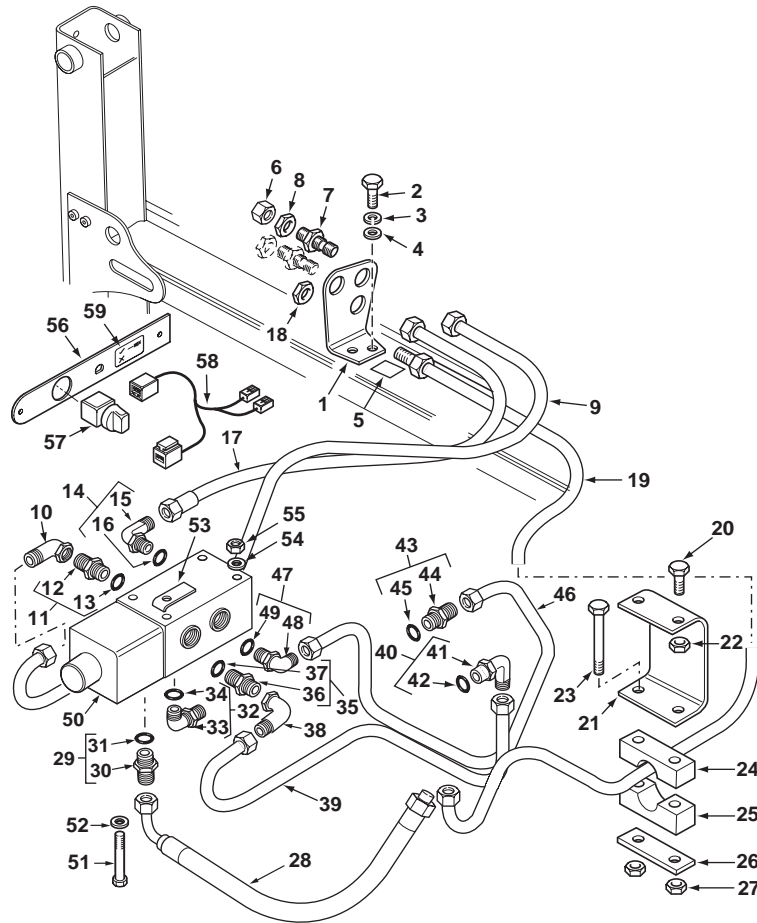

45	835025M1	43		1	O-Ring	Joint torique	Junta de tipo O
46	6109620M91			1	Tube Assy	Tuyauterie	Conjunto de tubería
47	358764X91			1	Elbow, 90°	Coude à 90°	Codo, 90°
48		47	▶ Ref. 47	1	Elbow	Coude	Codo
49	835025M1	47		1	O-Ring	Joint torique	Junta de tipo O
50	6108292M91			1	Valve, Priority	Soupape de priorité	Válvula de prioridad
51	3019894X1	M6 x 100		3	Screw	Vis	Tornillo
52	3019571X1			3	Washer	Rondelle	Arandela
53	6108445M1			1	Bracket	Patte de fixation	Pata de fijación
54	390971X1	M6		3	Washer	Rondelle	Arandela
55	1441500X1	M6		3	Nut, Lock	Écrou de blocage	Tuerca de retención
56	6109934M1			1	Plate	Plaque	Placa
57	6107165M91			1	Switch Assy	Ensemble commutat.	Conmutador, Conj.
58	6107467M92			1	Harness Assy	Ensemble de faisceau	Haz, Conj.
59	6109932M1	Aux Hyds Switch		1	Decal	Adhésif	Adhesivo



820 860 880
 TX760B TX860B

805 807 817 825 831 833 845

80001C02.1

6199042M3

1

Jan-06

Auxiliary Hydraulics
Hydraulique Auxiliaire
Circuito hidráulico auxiliar

Sideshift
Montage de Pelle Latéral
Excavadora de montaje horizontal

Telescopic Dipper
Balancier Téléscopique
Balancín telescópico

Rops
Rops
Rops

C-80002-01.1-A

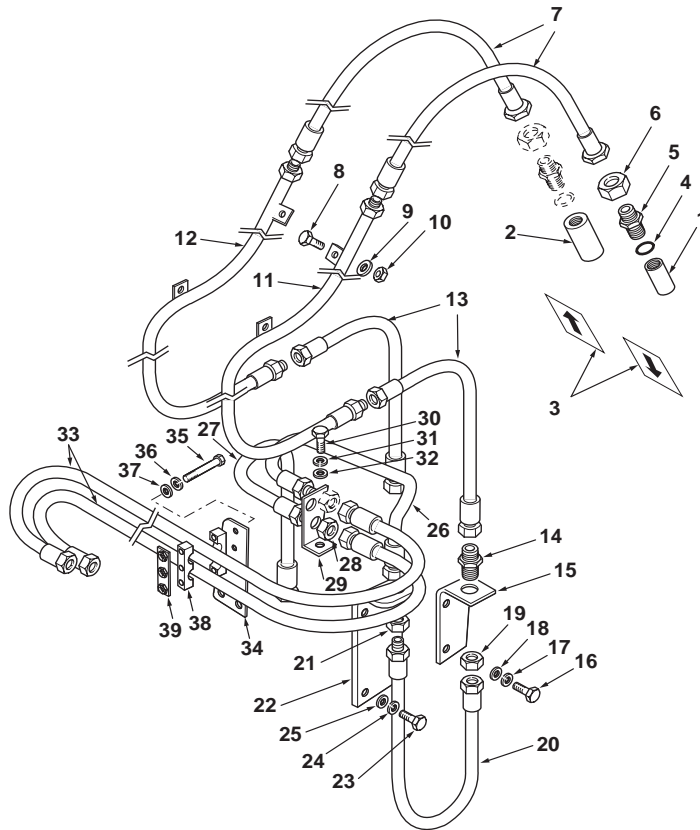

1	3516796M91	Male	1	Coupler, Quick	Coupleur rapide	Acoplador rápido
2	3516797M91	Female	1	Coupler, Quick	Coupleur rapide	Acoplador rápido
3	6106080M1	Arrow	2	Decal	Adhésif	Adhesivo
4	835025M1		2	O-Ring	Joint torique	Junta de tipo O
5	356269X1		2	Connector, Bulkhead	Passe-cloison	Pasatabiques
6	355575X1		2	Nut, Lock	Écrou de blocage	Tuerca de retención
7	6106190M91		2	Hose Assy	Ensemble de flexible	Flexible, Conj.
8	339761X1	M8 x 25	4	Screw	Vis	Tornillo
9	390972X1	M8	4	Washer	Rondelle	Arandela
10	394367X1	M8	4	Nut, Lock	Écrou de blocage	Tuerca de retención
11	6106186M91	◀	1	Tube Assy	Tuyauterie	Conjunto de tubería
12	6106188M91	▶	1	Tube Assy	Tuyauterie	Conjunto de tubería
13	6106185M91		2	Hose Assy	Ensemble de flexible	Flexible, Conj.
14	356269X1		2	Connector, Bulkhead	Passe-cloison	Pasatabiques
15	6101964M1	◀	1	Bracket	Patte de fixation	Pata de fijación
15	6101965M1	▶	1	Bracket	Patte de fixation	Pata de fijación
16	339123X1	M8 x 20	4	Bolt	Boulon	Perno
17	339374X1	M8	4	Washer, Lock	Rondelle de blocage	Arandela de freno
18	390972X1	M8	4	Washer	Rondelle	Arandela
19	355575X1		2	Nut, Lock	Écrou de blocage	Tuerca de retención
20	6101899M91		2	Hose Assy	Ensemble de flexible	Flexible, Conj.
21	355575X1		2	Nut, Lock	Écrou de blocage	Tuerca de retención
22	6101459M91		2	Bracket	Patte de fixation	Pata de fijación
23	339123X1	M8 x 20	4	Bolt	Boulon	Perno
24	339374X1	M8	4	Washer, Lock	Rondelle de blocage	Arandela de freno
25	390972X1	M8	4	Washer	Rondelle	Arandela
26	6101461M92		1	Tube Assy	Tuyauterie	Conjunto de tubería
27	6101463M92		1	Tube Assy	Tuyauterie	Conjunto de tubería
28	355575X1		2	Nut, Lock	Écrou de blocage	Tuerca de retención
29	6101466M3		1	Bracket	Patte de fixation	Pata de fijación
30	3009493X1	M10 x 30	1	Bolt	Boulon	Perno
31	339376X1	M10	1	Washer, Lock	Rondelle de blocage	Arandela de freno
32	390734X1	M10	1	Washer	Rondelle	Arandela
33	6101898M91		2	Hose Assy	Ensemble de flexible	Flexible, Conj.
34	6102026M1		1	Plate	Plaque	Placa
35	339891X1	M8 x 80	3	Screw	Vis	Tornillo
36	339374X1	M8	3	Washer, Lock	Rondelle de blocage	Arandela de freno
37	390972X1	M8	3	Washer	Rondelle	Arandela
38	3522055M3		2	Bracket, Clamp	Bride de fixation	Brida de fijación
39	6102132M91		1	Plate	Plaque	Placa



820
TX760B

806 808 832 834

80002C01.1

6199042M3

1

Jan-06

Auxiliary Hydraulics
Hydraulique Auxiliaire
Circuito hidráulico auxiliar

Sideshift
Montage de Pelle Latéral
Excavadora montaje horizontal

Telescopic Dipper
Balancier Téléscopique
Balancín telescópico

Rops
Rops
Rops

C-80002-02.1-A

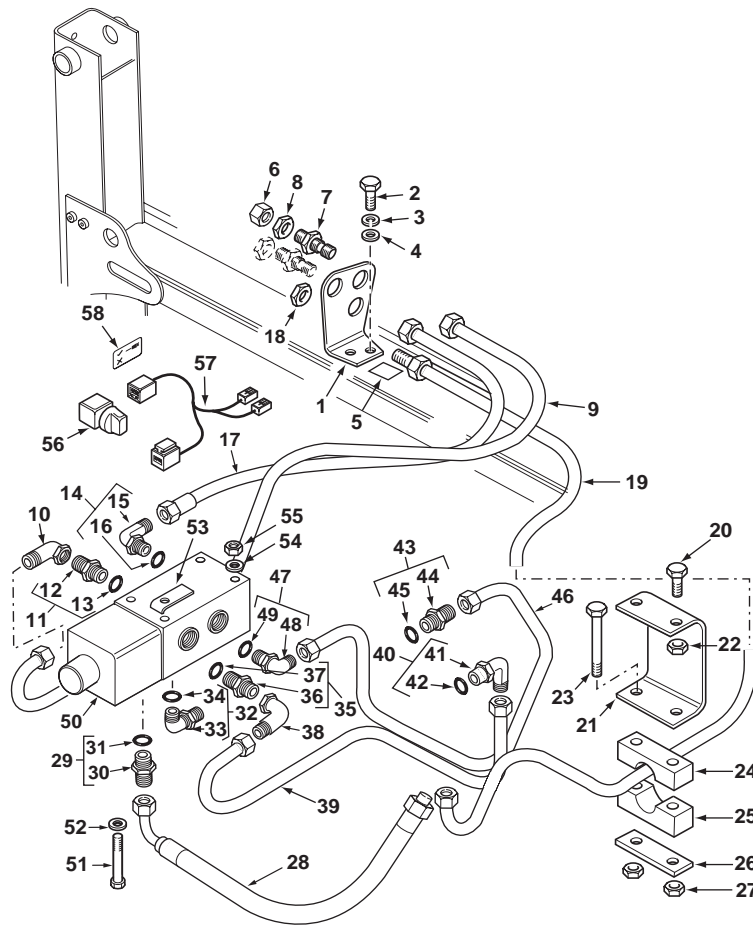

1	6109873M1		1	Bracket	Patte de fixation	Pata de fijación
2	3009491X1	M10 x 20	2	Screw	Vis	Tornillo
3	339376X1	M10	2	Washer, Lock	Rondelle de blocage	Arandela de freno
4	390734X1	M10	2	Washer	Rondelle	Arandela
5	6109756M1		1	Decal	Adhésif	Adhesivo
6	355782X1		1	Plug, Blank-Off	Obturateur	Obturador
7	356269X1		2	Connector, Bulkhead	Passe-cloison	Pasatabiques
8	355575X1		2	Nut, Lock	Écrou de blocage	Tuerca de retención
9	6109746M92		1	Tube Assy	Tuyauterie	Conjunto de tubería
10	366462X1		1	Elbow, 90°	Coude à 90°	Codo, 90°
11	835057M91		1	Connector Assy	Ensemble connexion	Conexión, Conj.
12		11	1	Connector	Connecteur	Conector
13	835025M1	11	1	O-Ring	Joint torique	Junta de tipo O
14	358764X91		1	Elbow, 90°	Coude à 90°	Codo, 90°
15		14	1	Elbow	Coude	Codo
16	835025M1	14	1	O-Ring	Joint torique	Junta de tipo O
17	6107408M93		1	Tube Assy	Tuyauterie	Conjunto de tubería
18	355575X1		1	Nut, Lock	Écrou de blocage	Tuerca de retención
19	6109846M91		1	Tube Assy	Tuyauterie	Conjunto de tubería
20	339666X1	M6 x 20	2	Screw	Vis	Tornillo
21	6109926M1		1	Bracket	Patte de fixation	Pata de fijación
22	1441500X1	M6	2	Nut, Lock	Écrou de blocage	Tuerca de retención
23	1440922X1	M6 x 60	2	Screw	Vis	Tornillo
24	3520340M3		1	Clamp	Collier de serrage	Argolla de cierre
25	1462584M1		1	Clamp	Collier de serrage	Argolla de cierre
26	1462583M1		1	Plate	Plaque	Placa
27	1441500X1	M6	2	Nut, Lock	Écrou de blocage	Tuerca de retención
28	6108513M91		1	Hose Assy	Ensemble de flexible	Flexible, Conj.
29	365715X91	1,1/16" - 7/8" UNF	1	Connector Assy	Ensemble connexion	Conexión, Conj.
30		29	1	Connector	Connecteur	Conector
31	835025M1	29	1	O-Ring	Joint torique	Junta de tipo O
32	368113X91		1	Elbow, 90°	Coude à 90°	Codo, 90°
33		32	1	Elbow	Coude	Codo
34	835025M1	32	1	O-Ring	Joint torique	Junta de tipo O
35	835057M91		1	Connector Assy	Ensemble connexion	Conexión, Conj.
36		36	1	Connector	Connecteur	Conector
37	835025M1	36	1	O-Ring	Joint torique	Junta de tipo O
38	366462X1		1	Elbow, 90°	Coude à 90°	Codo, 90°
39	6109622M91		1	Tube Assy	Tuyauterie	Conjunto de tubería
40	358764X91		1	Elbow, 90°	Coude à 90°	Codo, 90°
41		40	1	Elbow	Coude	Codo
42	835025M1	40	1	O-Ring	Joint torique	Junta de tipo O
43	835057M91		1	Connector Assy	Ensemble connexion	Conexión, Conj.
44		43	1	Connector	Connecteur	Conector

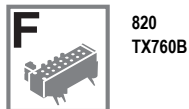

820
TX760B

806 808 832 834

80002C02.1

6199042M3

1

Jan-06

Auxiliary Hydraulics
Hydraulique Auxiliaire
Circuito hidráulico auxiliar

Sideshift
Montage de Pelle Latéral
Excavadora montaje horizontal

Telescopic Dipper
Balancier Téléscopique
Balancín telescópico

Rops
Rops
Rops

C-80002-02.1-A

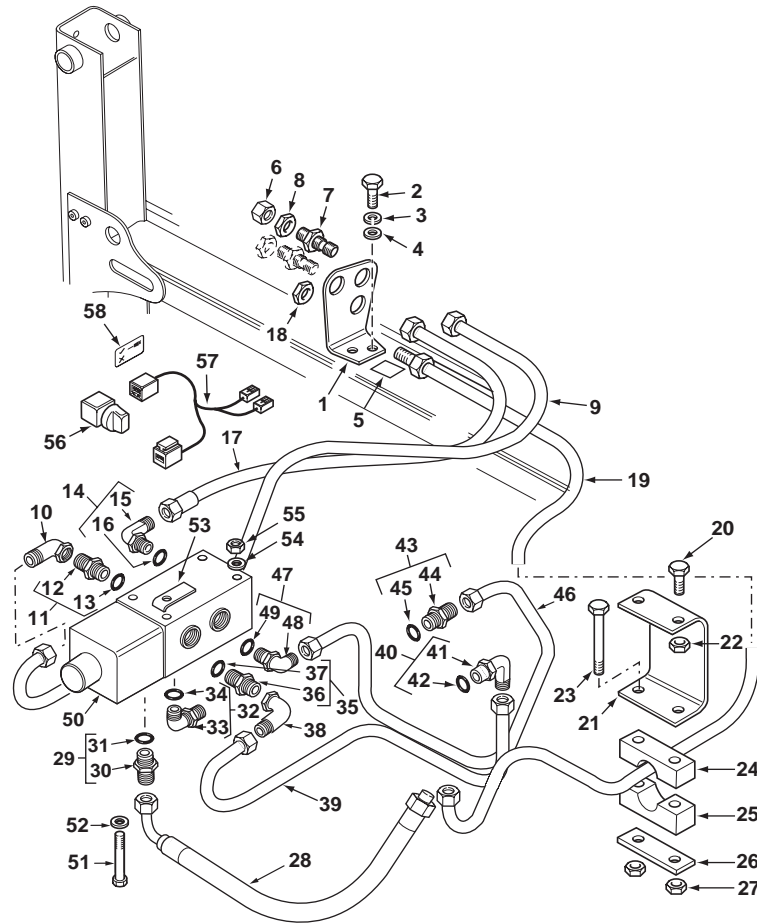

45	835025M1	43		1	O-Ring	Joint torique	Junta de tipo O
46	6109620M91			1	Tube Assy	Tuyauterie	Conjunto de tubería
47	358764X91			1	Elbow, 90°	Coude à 90°	Codo, 90°
48		47	▶ Ref. 47	1	Elbow	Coude	Codo
49	835025M1	47		1	O-Ring	Joint torique	Junta de tipo O
50	6108292M91			1	Valve, Priority	Soupape de priorité	Válvula de prioridad
51	3019894X1	M6 x 100		3	Screw	Vis	Tornillo
52	3019571X1			3	Washer	Rondelle	Arandela
53	6108445M1			1	Bracket	Patte de fixation	Pata de fijación
54	390971X1	M6		3	Washer	Rondelle	Arandela
55	1441500X1	M6		3	Nut, Lock	Écrou de blocage	Tuerca de retención
56	6107165M91			1	Switch Assy	Ensemble commutat.	Conmutador, Conj.
57	6107467M92			1	Harness Assy	Ensemble de faisceau	Haz, Conj.
58	6109932M1	Aux Hyds Switch		1	Decal	Adhésif	Adhesivo



820
TX760B

806 808 832 834

80002C02.1

6199042M3

1

Jan-06

Auxiliary Hydraulics
Hydraulique Auxiliaire
Circuito hidráulico auxiliar

Sideshift
Montage de Pelle Latéral
Excavadora de montaje horizontal

Telescopic Dipper
Balancier Téléscopique
Balancín telescópico

4 Wheel Steer
 4 Wheel Steer
 4 Wheel Steer

C-80003-01.1-A

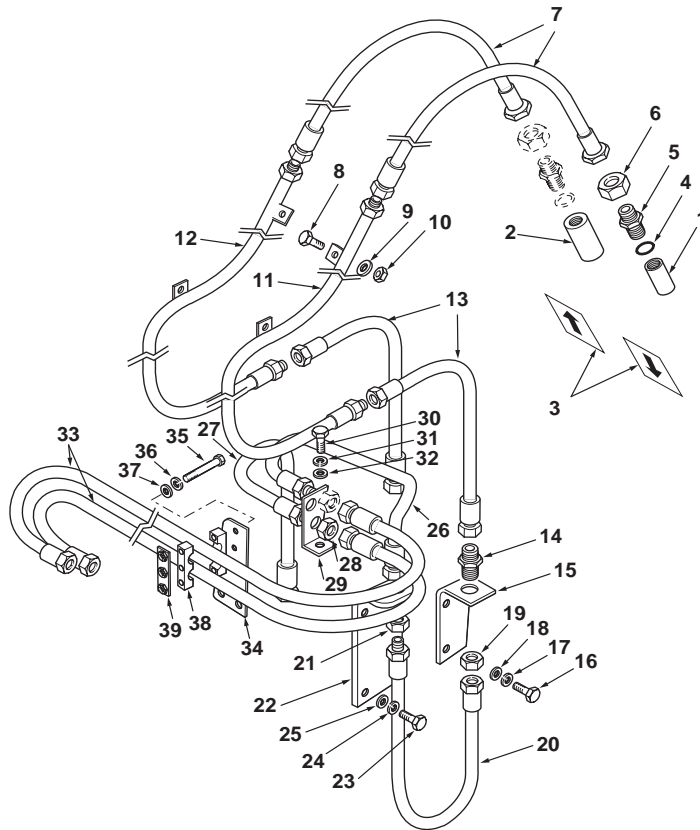

1	3516796M91	Male	1	Coupler, Quick	Coupleur rapide	Acoplador rápido
2	3516797M91	Female	1	Coupler, Quick	Coupleur rapide	Acoplador rápido
3	6106080M1	Arrow	2	Decal	Adhésif	Adhesivo
4	835025M1		2	O-Ring	Joint torique	Junta de tipo O
5	356269X1		2	Connector, Bulkhead	Passe-cloison	Pasatabiques
6	355575X1		2	Nut, Lock	Écrou de blocage	Tuerca de retención
7	6106190M91		2	Hose Assy	Ensemble de flexible	Flexible, Conj.
8	339761X1	M8 x 25	4	Screw	Vis	Tornillo
9	390972X1	M8	4	Washer	Rondelle	Arandela
10	394367X1	M8	4	Nut, Lock	Écrou de blocage	Tuerca de retención
11	6106186M91	◀	1	Tube Assy	Tuyauterie	Conjunto de tubería
12	6106188M91	▶	1	Tube Assy	Tuyauterie	Conjunto de tubería
13	6106185M91		2	Hose Assy	Ensemble de flexible	Flexible, Conj.
14	356269X1		2	Connector, Bulkhead	Passe-cloison	Pasatabiques
15	6101964M1	◀	1	Bracket	Patte de fixation	Pata de fijación
15	6101965M1	▶	1	Bracket	Patte de fixation	Pata de fijación
16	339123X1	M8 x 20	4	Bolt	Boulon	Perno
17	339374X1	M8	4	Washer, Lock	Rondelle de blocage	Arandela de freno
18	390972X1	M8	4	Washer	Rondelle	Arandela
19	355575X1		2	Nut, Lock	Écrou de blocage	Tuerca de retención
20	6101899M91		2	Hose Assy	Ensemble de flexible	Flexible, Conj.
21	355575X1		2	Nut, Lock	Écrou de blocage	Tuerca de retención
22	6101459M91		2	Bracket	Patte de fixation	Pata de fijación
23	339123X1	M8 x 20	4	Bolt	Boulon	Perno
24	339374X1	M8	4	Washer, Lock	Rondelle de blocage	Arandela de freno
25	390972X1	M8	4	Washer	Rondelle	Arandela
26	6101461M92		1	Tube Assy	Tuyauterie	Conjunto de tubería
27	6101463M92		1	Tube Assy	Tuyauterie	Conjunto de tubería
28	355575X1		2	Nut, Lock	Écrou de blocage	Tuerca de retención
29	6101466M3		1	Bracket	Patte de fixation	Pata de fijación
30	3009493X1	M10 x 30	1	Bolt	Boulon	Perno
31	339376X1	M10	1	Washer, Lock	Rondelle de blocage	Arandela de freno
32	390734X1	M10	1	Washer	Rondelle	Arandela
33	6101898M91		2	Hose Assy	Ensemble de flexible	Flexible, Conj.
34	6102026M1		1	Plate	Plaque	Placa
35	339891X1	M8 x 80	3	Screw	Vis	Tornillo
36	339374X1	M8	3	Washer, Lock	Rondelle de blocage	Arandela de freno
37	390972X1	M8	3	Washer	Rondelle	Arandela
38	3522055M3		2	Bracket, Clamp	Bride de fixation	Brida de fijación
39	6102132M91		1	Plate	Plaque	Placa



880 970 980
 TX860B

855 921 931

80003C01.1

6199042M3

1

Jan-06

Auxiliary Hydraulics
Hydraulique Auxiliaire
Circuito hidráulico auxiliar

Sideshift
Montage de Pelle Latéral
Excavadora de montaje horizontal

Telescopic Dipper
Balancier Téléscopique
Balancín telescópico

4 Wheel Steer
 4 Wheel Steer
 4 Wheel Steer

C-80003-02.1-A

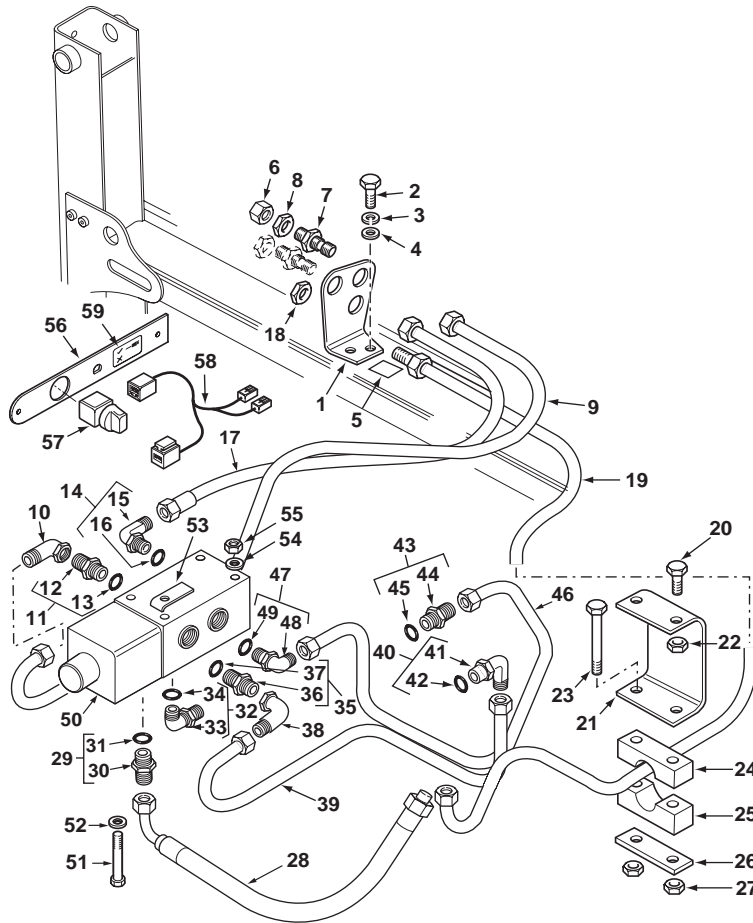

1	6109873M1		1	Bracket	Patte de fixation	Pata de fijación
2	3009491X1	M10 x 20	2	Screw	Vis	Tornillo
3	339376X1	M10	2	Washer, Lock	Rondelle de blocage	Arandela de freno
4	390734X1	M10	2	Washer	Rondelle	Arandela
5	6109756M1		1	Decal	Adhésif	Adhesivo
6	355782X1		1	Plug, Blank-Off	Obturateur	Obturador
7	356269X1		2	Connector, Bulkhead	Passe-cloison	Pasatabiques
8	355575X1		2	Nut, Lock	Écrou de blocage	Tuerca de retención
9	6109746M92		1	Tube Assy	Tuyauterie	Conjunto de tubería
10	366462X1		1	Elbow, 90°	Coude à 90°	Codo, 90°
11	835057M91		1	Connector Assy	Ensemble connexion	Conexión, Conj.
12		11	1	Connector	Connecteur	Conector
13	835025M1	11	1	O-Ring	Joint torique	Junta de tipo O
14	358764X91		1	Elbow, 90°	Coude à 90°	Codo, 90°
15		14	1	Elbow	Coude	Codo
16	835025M1	14	1	O-Ring	Joint torique	Junta de tipo O
17	6107408M93		1	Tube Assy	Tuyauterie	Conjunto de tubería
18	355575X1		1	Nut, Lock	Écrou de blocage	Tuerca de retención
19	6109846M91		1	Tube Assy	Tuyauterie	Conjunto de tubería
20	339666X1	M6 x 20	2	Screw	Vis	Tornillo
21	6109926M1		1	Bracket	Patte de fixation	Pata de fijación
22	1441500X1	M6	2	Nut, Lock	Écrou de blocage	Tuerca de retención
23	1440922X1	M6 x 60	2	Screw	Vis	Tornillo
24	3520340M3		1	Clamp	Collier de serrage	Argolla de cierre
25	1462584M1		1	Clamp	Collier de serrage	Argolla de cierre
26	1462583M1		1	Plate	Plaque	Placa
27	1441500X1	M6	2	Nut, Lock	Écrou de blocage	Tuerca de retención
28	6108513M91		1	Hose Assy	Ensemble de flexible	Flexible, Conj.
29	365715X91	1,1/16" - 7/8" UNF	1	Connector Assy	Ensemble connexion	Conexión, Conj.
30		29	1	Connector	Connecteur	Conector
31	835025M1	29	1	O-Ring	Joint torique	Junta de tipo O
32	368113X91		1	Elbow, 90°	Coude à 90°	Codo, 90°
33		32	1	Elbow	Coude	Codo
34	835025M1	32	1	O-Ring	Joint torique	Junta de tipo O
35	835057M91		1	Connector Assy	Ensemble connexion	Conexión, Conj.
36		36	1	Connector	Connecteur	Conector
37	835025M1	36	1	O-Ring	Joint torique	Junta de tipo O
38	366462X1		1	Elbow, 90°	Coude à 90°	Codo, 90°
39	6109622M91		1	Tube Assy	Tuyauterie	Conjunto de tubería
40	358764X91		1	Elbow, 90°	Coude à 90°	Codo, 90°
41		40	1	Elbow	Coude	Codo
42	835025M1	40	1	O-Ring	Joint torique	Junta de tipo O
43	835057M91		1	Connector Assy	Ensemble connexion	Conexión, Conj.
44		43	1	Connector	Connecteur	Conector



880 970 980
 TX860B

855 921 931

80003C02.1

6199042M3

1

Jan-06

Auxiliary Hydraulics
Hydraulique Auxiliaire
Circuito hidráulico auxiliar

Sideshift
Montage de Pelle Latéral
Excavadora de montaje horizontal

Telescopic Dipper
Balancier Téléscopique
Balancín telescópico

4 Wheel Steer
 4 Wheel Steer
 4 Wheel Steer

C-80003-02.1-A

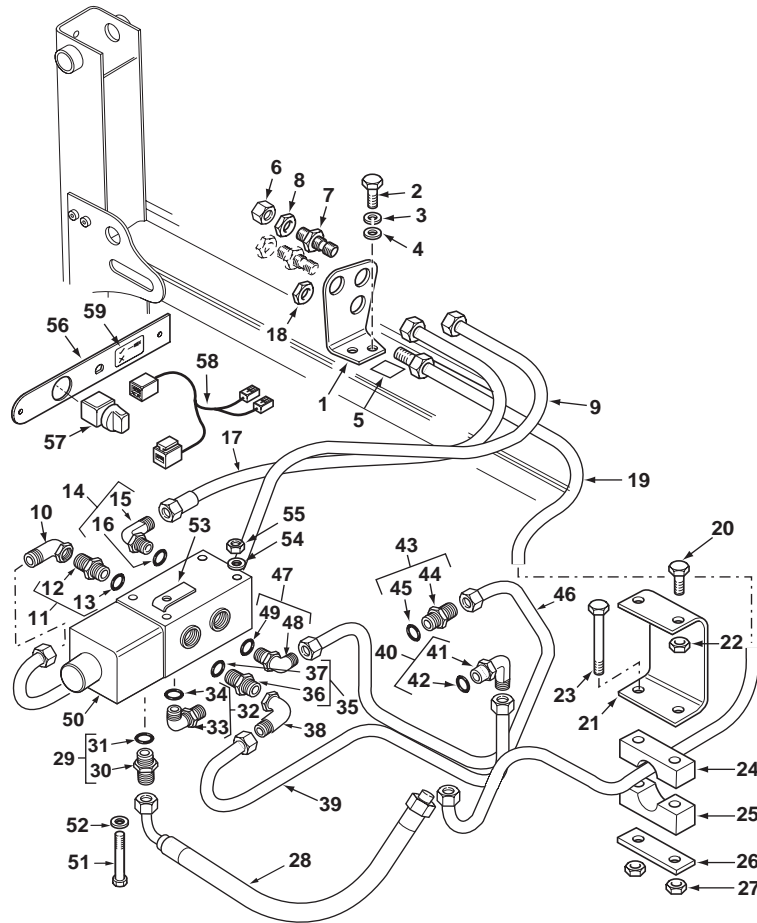

45	835025M1	43		1	O-Ring	Joint torique	Junta de tipo O
46	6109620M91			1	Tube Assy	Tuyauterie	Conjunto de tubería
47	358764X91			1	Elbow, 90°	Coude à 90°	Codo, 90°
48		47	▶ Ref. 47	1	Elbow	Coude	Codo
49	835025M1	47		1	O-Ring	Joint torique	Junta de tipo O
50	6108292M91			1	Valve, Priority	Soupape de priorité	Válvula de prioridad
51	3019894X1	M6 x 100		3	Screw	Vis	Tornillo
52	3019571X1			3	Washer	Rondelle	Arandela
53	6108445M1			1	Bracket	Patte de fixation	Pata de fijación
54	390971X1	M6		3	Washer	Rondelle	Arandela
55	1441500X1	M6		3	Nut, Lock	Écrou de blocage	Tuerca de retención
56	6110013M1			1	Plate	Plaque	Placa
57	6107165M91			1	Switch Assy	Ensemble commutat.	Conmutador, Conj.
58	6107467M92			1	Harness Assy	Ensemble de faisceau	Haz, Conj.
59	6109933M1	Aux Hyds Switch		1	Decal	Adhésif	Adhesivo



880 970 980
 TX860B

855 921 931

80003C02.1

6199042M3

1

Jan-06

Auxiliary Hydraulics
Hydraulique Auxiliaire
Circuito hidráulico auxiliar

Sideshift
Montage de Pelle Latéral
Excavadora de montaje horizontal

Standard Dipper
Balancier Standard
Balancín estándar

C-80004-01.1-A

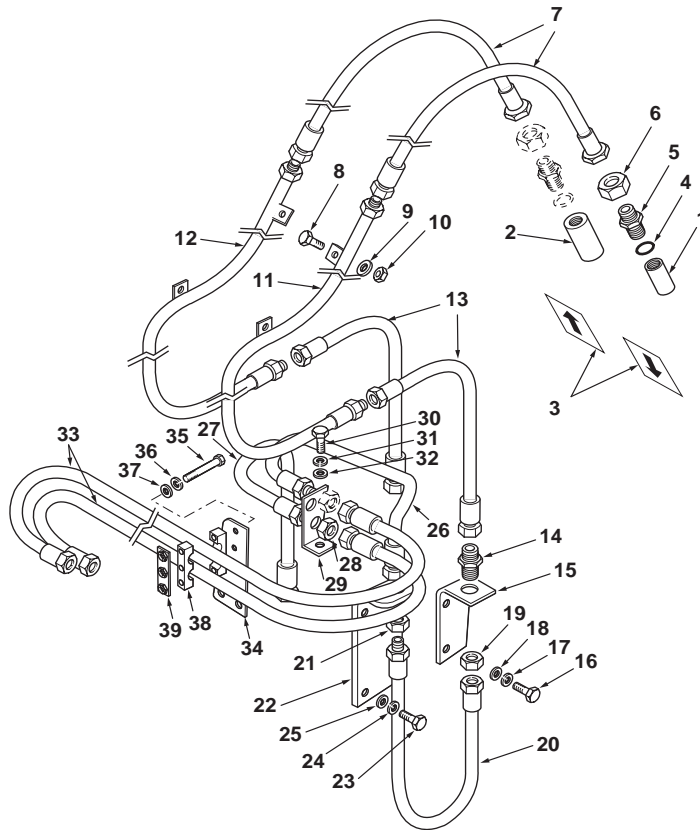

1	3516796M91	Male	1	Coupler, Quick	Coupleur rapide	Acoplador rápido
2	3516797M91	Female	1	Coupler, Quick	Coupleur rapide	Acoplador rápido
3	6106080M1	Arrow	2	Decal	Adhésif	Adhesivo
4	835025M1		2	O-Ring	Joint torique	Junta de tipo O
5	356269X1		2	Connector, Bulkhead	Passe-cloison	Pasatabiques
6	355575X1		2	Nut, Lock	Écrou de blocage	Tuerca de retención
7	6106190M91		2	Hose Assy	Ensemble de flexible	Flexible, Conj.
8	339761X1	M8 x 25	4	Screw	Vis	Tornillo
9	390972X1	M8	4	Washer	Rondelle	Arandela
10	394367X1	M8	4	Nut, Lock	Écrou de blocage	Tuerca de retención
11	6106186M91	◀	1	Tube Assy	Tuyauterie	Conjunto de tubería
12	6106188M91	▶	1	Tube Assy	Tuyauterie	Conjunto de tubería
13	6106185M91		2	Hose Assy	Ensemble de flexible	Flexible, Conj.
14	356269X1		2	Connector, Bulkhead	Passe-cloison	Pasatabiques
15	6101964M1	◀	1	Bracket	Patte de fixation	Pata de fijación
15	6101965M1	▶	1	Bracket	Patte de fixation	Pata de fijación
16	339123X1	M8 x 20	4	Bolt	Boulon	Perno
17	339374X1	M8	4	Washer, Lock	Rondelle de blocage	Arandela de freno
18	390972X1	M8	4	Washer	Rondelle	Arandela
19	355575X1		2	Nut, Lock	Écrou de blocage	Tuerca de retención
20	6101899M91		2	Hose Assy	Ensemble de flexible	Flexible, Conj.
21	355575X1		2	Nut, Lock	Écrou de blocage	Tuerca de retención
22	6101459M91		2	Bracket	Patte de fixation	Pata de fijación
23	339123X1	M8 x 20	4	Bolt	Boulon	Perno
24	339374X1	M8	4	Washer, Lock	Rondelle de blocage	Arandela de freno
25	390972X1	M8	4	Washer	Rondelle	Arandela
26	6101461M92		1	Tube Assy	Tuyauterie	Conjunto de tubería
27	6101463M92		1	Tube Assy	Tuyauterie	Conjunto de tubería
28	355575X1		2	Nut, Lock	Écrou de blocage	Tuerca de retención
29	6101466M3		1	Bracket	Patte de fixation	Pata de fijación
30	3009493X1	M10 x 30	1	Bolt	Boulon	Perno
31	339376X1	M10	1	Washer, Lock	Rondelle de blocage	Arandela de freno
32	390734X1	M10	1	Washer	Rondelle	Arandela
33	6101898M91		2	Hose Assy	Ensemble de flexible	Flexible, Conj.
34	6102026M1		1	Plate	Plaque	Placa
35	339891X1	M8 x 80	3	Screw	Vis	Tornillo
36	339374X1	M8	3	Washer, Lock	Rondelle de blocage	Arandela de freno
37	390972X1	M8	3	Washer	Rondelle	Arandela
38	3522055M3		2	Bracket, Clamp	Bride de fixation	Brida de fijación
39	6102132M91		1	Plate	Plaque	Placa



820 860 880 970 980
 TX760B TX860B
 TX970B

805 806 807 808 817 825 831 832 833 834 845 855 921 931 932

80004C01.1

6199042M3

1

Jan-06

Auxiliary Hydraulics
Hydraulique Auxiliaire
Circuito hidráulico auxiliar

Sideshift
Montage de Pelle Latéral
Excavadora de montaje horizontal

Standard Dipper
Balancier Standard
Balancín estándar

C-80004-02.1-A

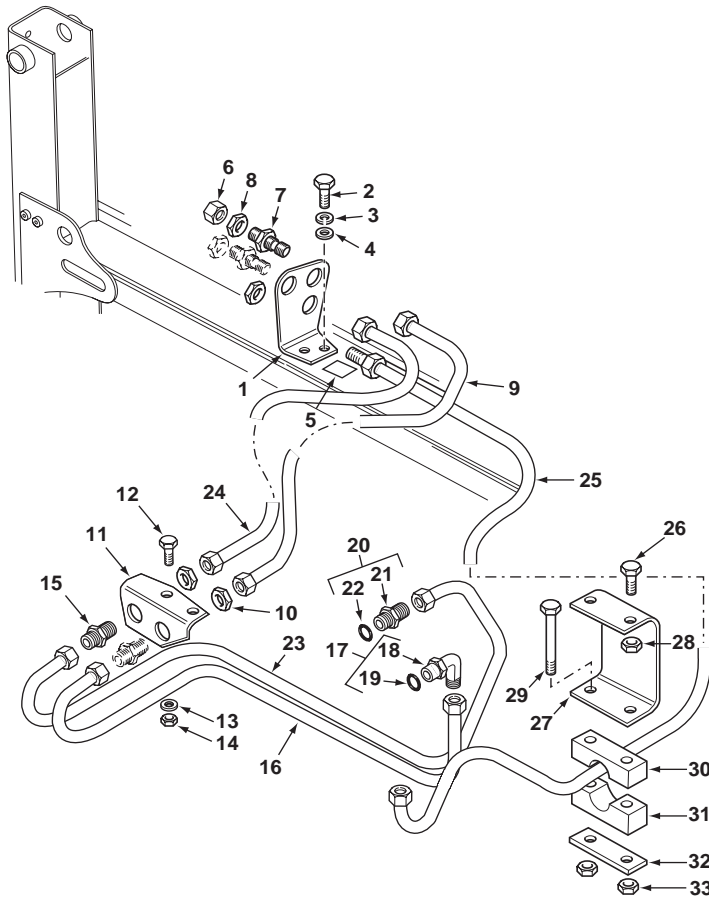

1	6109873M1		1	Bracket	Patte de fixation	Pata de fijación
2	3009491X1	M10 x 20	2	Screw	Vis	Tornillo
3	339376X1	M10	2	Washer, Lock	Rondelle de blocage	Arandela de freno
4	390734X1	M10	2	Washer	Rondelle	Arandela
5	6109756M1		1	Decal	Adhésif	Adhesivo
6	355782X1		1	Plug, Blank-Off	Obturateur	Obturador
7	356269X1		2	Connector, Bulkhead	Passe-cloison	Pasatabiques
8	355575X1		2	Nut, Lock	Écrou de blocage	Tuerca de retención
9	6110029M92		1	Tube Assy	Tuyauterie	Conjunto de tubería
10	355575X1		2	Nut, Lock	Écrou de blocage	Tuerca de retención
11	6110076M1		1	Bracket	Patte de fixation	Pata de fijación
12	339804X1	M6 x 25	2	Screw	Vis	Tornillo
13	390971X1	M6	2	Washer	Rondelle	Arandela
14	1441500X1	M6	2	Nut, Lock	Écrou de blocage	Tuerca de retención
15	356269X1		2	Connector, Bulkhead	Passe-cloison	Pasatabiques
16	6110031M91		1	Tube Assy	Tuyauterie	Conjunto de tubería
17	358764X91		1	Elbow, 90°	Coude à 90°	Codo, 90°
18		17	1	Elbow	Coude	Codo
19	835025M1	17	1	O-Ring	Joint torique	Junta de tipo O
20	835057M91		1	Connector Assy	Ensemble connexion	Conexión, Conj.
21		20	1	Connector	Connecteur	Conector
22	835025M1	20	1	O-Ring	Joint torique	Junta de tipo O
23	6110077M91		1	Tube Assy	Tuyauterie	Conjunto de tubería
24	6107408M93		1	Tube Assy	Tuyauterie	Conjunto de tubería
25	6109846M91		1	Tube Assy	Tuyauterie	Conjunto de tubería
26	339666X1	M6 x 20	2	Screw	Vis	Tornillo
27	6109926M1		1	Bracket	Patte de fixation	Pata de fijación
28	1441500X1	M6	2	Nut, Lock	Écrou de blocage	Tuerca de retención
29	1440922X1	M6 x 60	2	Screw	Vis	Tornillo
30	3520340M3		1	Clamp	Collier de serrage	Argolla de cierre
31	1462584M1		1	Clamp	Collier de serrage	Argolla de cierre
32	1462583M1		1	Plate	Plaque	Placa
33	1441500X1	M6	2	Nut, Lock	Écrou de blocage	Tuerca de retención



820 860 880 970 980
 TX760B TX860B
 TX970B

805 806 807 808 817 825 831 832 833 834 845 855 921 931 932

80004C02.1

6199042M3

1

Jan-06

Auxiliary Hydraulics
Hydraulique Auxiliaire
Circuito hidráulico auxiliar

Sideshift
Montage de Pelle Latéral
Excavadora de montaje horizontal

Control Pedal
Pédale de Commande
Pedal de control

C-80004-03.1-A

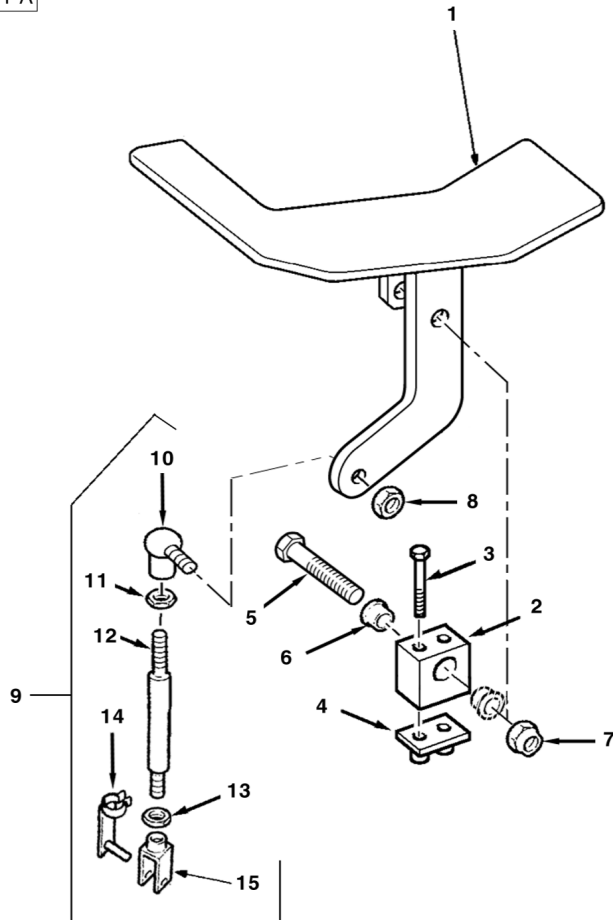

1	6106874M91		1	Pedal Assy	Ensemble de pédale	Pedal, Conj.
2	6106734M1		1	Pivot	Pivot	Pivote
3	3001758X1	M6 x 50	2	Screw	Vis	Tornillo
4	3519538M1		1	Plate, Base	Plaque de base	Placa de base
5	6106981M1	M10 x 60	1	Bolt	Boulon	Perno
6	6106866M1		2	Bushing	Bague	Anillo
7	1440329X1	M10	1	Nut, Lock	Écrou de blocage	Tuerca de retención
8	394367X1	M8	1	Nut, Lock	Écrou de blocage	Tuerca de retención
9	6106724M92		1	Rod Assy	Ensemble tringlerie	Tirantes, Conj.
10	3517518M1	9	1	Ball Joint	Rotule	Rotula
11	339169X1	9 M8	1	Nut	Écrou	Tuerca
12		9 Ref.9	1	Rod	Tringle	Vástago
13	3519650M1	9 M8 LH Thread	1	Nut	Écrou	Tuerca
14	3520666M1	9	1	Pin, Clevis	Axe de chape	Eje de brida
15	3519590M1	9 LH Thread	1	Clevis	Chape	Brida
16	6101865M2		1	Decal	Adhésif	Adhesivo



820 860 880 970 980
 TX760B TX860B
 TX970B

805 806 807 808 817 825 831 832 833 834 845 855 921 931 932

80004C03.1

6199042M3

1

Jan-06

Extendahoe Hydraulics
Circuit Hydraulique Extendahoe
Circuito hidráulico Extendahoe

Less Control Pedal
Sans Pédale de Commande
Sin pedal de control

C-78016-01.1-A

1	6110317M1	Rear Mat	1	Bung	Bonde	Casquillo
---	-----------	----------	---	------	-------	-----------

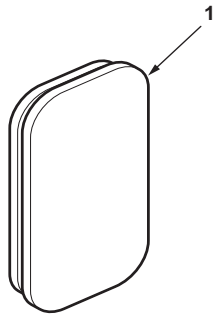

820 860 880 970 980
TX760B TX860B
TX870B TX970B

801 802 803 804 805 806 807 808 809 810 811 812 813 814 815 816 817 821 822
823 824 825 831 832 833 834 841 842 843 844 845 851 852 853 854 855 921 922
923 931 932

78016C01.1

6199042M3

1

Jan-06

Extendahoe Hydraulics
Circuit Hydraulique Extendahoe
Circuito hidráulico Extendahoe

Centremount
Montage de Pelle Central
Excavadora de montaje central

Without Auxiliary Hydraulics
 Sans Hydraulique Auxiliaire
 Sin hidraulico auxiliar

4.5m
 4.5m
 4.5m

C-78012-01.1-A

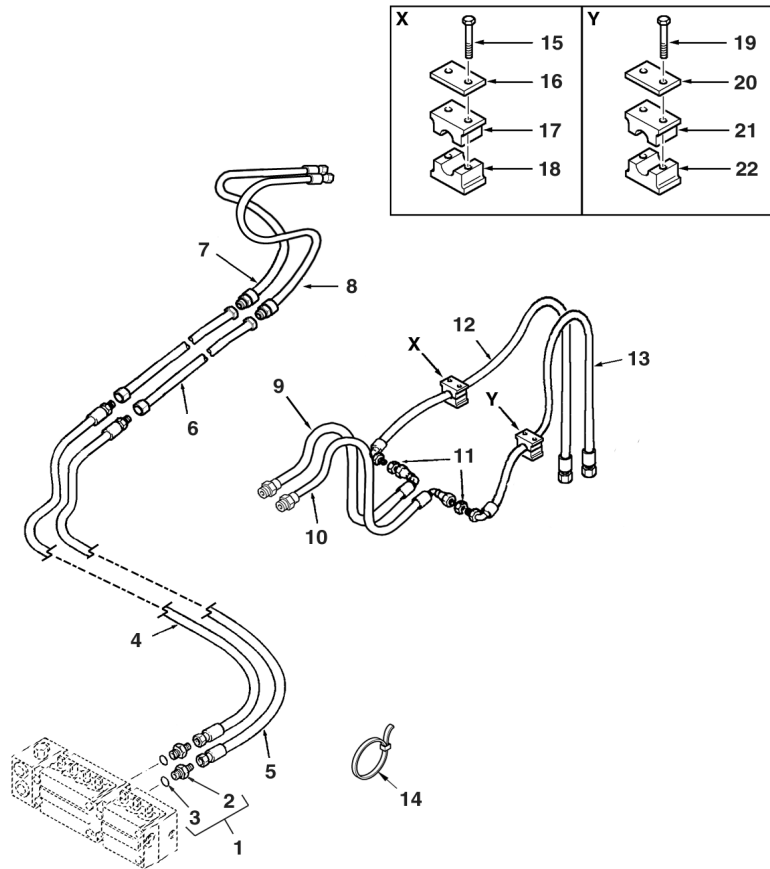

1	365715X91		1, 1/16" - 7/8" UNF	2	Connector Assy	Ensemble connexion	Conexión, Conj.
2		1	Ref. 1	1	Connector	Connecteur	Conector
3	835025M1	1		1	O-Ring	Joint torique	Junta de tipo O
4	6107464M93		Dark Green	1	Hose Assy	Ensemble de flexible	Flexible, Conj.
5	6107465M92		Black	1	Hose Assy	Ensemble de flexible	Flexible, Conj.
6	6101773M91			2	Tube Assy	Tuyauterie	Conjunto de tubería
7	6101741M91		Dark Green	1	Hose Assy	Ensemble de flexible	Flexible, Conj.
8	6101757M91		Black	1	Hose Assy	Ensemble de flexible	Flexible, Conj.
9	6101739M91		Brown	1	Hose Assy	Ensemble de flexible	Flexible, Conj.
10	6101740M91		White	1	Hose Assy	Ensemble de flexible	Flexible, Conj.
11	355574X1			2	Nut	Écrou	Tuerca
12	6101007M91		Brown	1	Hose Assy	Ensemble de flexible	Flexible, Conj.
13	6101008M91		White	1	Hose Assy	Ensemble de flexible	Flexible, Conj.
14	1664405M1			2	Tie, Cable	Attache câble	Enlace de Cable
15	339229X1		M6 x 40	2	Screw	Vis	Tornillo
16	1462583M1			1	Plate	Plaque	Placa
17	6102170M1			1	Bracket, Clamp	Bride de fixation	Brida de fijación
18	6102170M1			1	Bracket, Clamp	Bride de fixation	Brida de fijación
19	339229X1		M6 x 40	2	Screw	Vis	Tornillo
20	1462583M1			1	Plate	Plaque	Placa
21	6102788M1			1	Bracket, Clamp	Bride de fixation	Brida de fijación
22	6102788M1			1	Bracket, Clamp	Bride de fixation	Brida de fijación



820 860 880 970
 TX760B TX860B

801 802 803 804 809 810 813 814 821 822 831 832 841 842 851 852 922

78012C01.1

6199042M3

1

Jan-06

Extendahoe Hydraulics
 Circuit Hydraulique Extendahoe
 Circuito hidráulico Extendahoe

Centremount
 Montage de Pelle Central
 Excavadora de montaje central

Control Pedal
 Pédale de Commande
 Pedal de control

C-78012-02.1-A

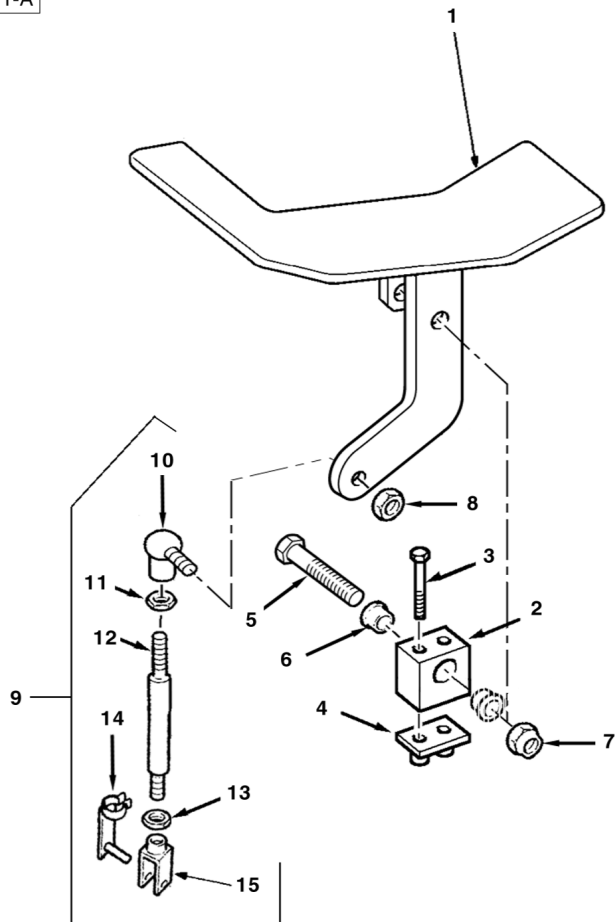

1	6106874M91		1	Pedal Assy	Ensemble de pédale	Pedal, Conj.
2	6106734M1		1	Pivot	Pivot	Pivote
3	3001758X1	M6 x 50	2	Screw	Vis	Tornillo
4	3519538M1		1	Plate, Base	Plaque de base	Placa de base
5	6106981M1	M10 x 60	1	Bolt	Boulon	Perno
6	6106866M1		2	Bushing	Bague	Anillo
7	1440329X1	M10	1	Nut, Lock	Écrou de blocage	Tuerca de retención
8	394367X1	M8	1	Nut, Lock	Écrou de blocage	Tuerca de retención
9	6106724M92		1	Rod Assy	Ensemble tringlerie	Tirantes, Conj.
10	3517518M1	9	1	Ball Joint	Rotule	Rotula
11	339169X1	9 M8	1	Nut	Écrou	Tuerca
12		9 Ref. 9	1	Rod	Tringle	Vástago
13	3519650M1	9 M8 LH Thread	1	Nut	Écrou	Tuerca
14	3520666M1	9	1	Pin, Clevis	Axe de chape	Eje de brida
15	3519590M1	9 LH Thread	1	Clevis	Chape	Brida
16	6101865M2		1	Decal	Adhésif	Adhesivo



820 860 880 970
 TX760B TX860B

801 802 803 804 809 810 813 814 821 822 831 832 841 842 851 852 922

78012C02.1

6199042M3

1

Jan-06

Extendahoe Hydraulics
Circuit Hydraulique Extendahoe
Circuito hidráulico Extendahoe

Centremount
Montage de Pelle Central
Excavadora de montaje central

Without Auxiliary Hydraulics
 Sans Hydraulique Auxiliaire
 Sin hidraulico auxiliar

4.9m
 4.9m
 4.9m

C-78013-01.1-A

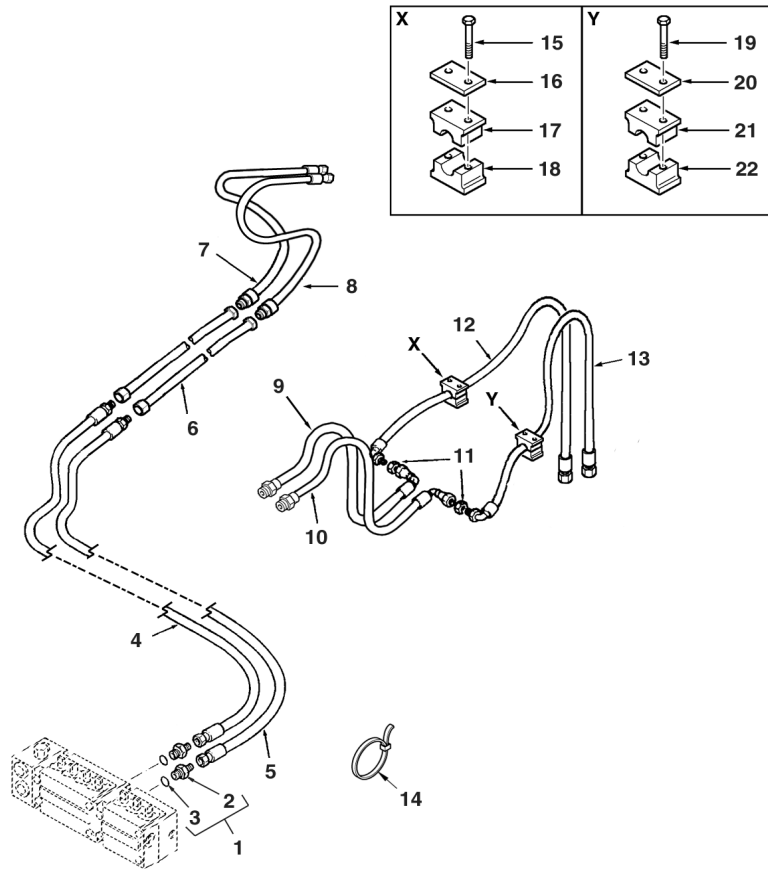

1	365715X91		1, 1/16" - 7/8" UNF	2	Connector Assy	Ensemble connexion	Conexión, Conj.
2		1	Ref. 1	1	Connector	Connecteur	Conector
3	835025M1	1		1	O-Ring	Joint torique	Junta de tipo O
4	6107464M93		Dark Green	1	Hose Assy	Ensemble de flexible	Flexible, Conj.
5	6107465M92		Black	1	Hose Assy	Ensemble de flexible	Flexible, Conj.
6	6101734M91			2	Tube Assy	Tuyauterie	Conjunto de tubería
7	6101741M91		Dark Green	1	Hose Assy	Ensemble de flexible	Flexible, Conj.
8	6101757M91		Black	1	Hose Assy	Ensemble de flexible	Flexible, Conj.
9	6101739M91		Brown	1	Hose Assy	Ensemble de flexible	Flexible, Conj.
10	6101740M91		White	1	Hose Assy	Ensemble de flexible	Flexible, Conj.
11	355574X1			2	Nut	Écrou	Tuerca
12	6101007M91		Brown	1	Hose Assy	Ensemble de flexible	Flexible, Conj.
13	6101008M91		White	1	Hose Assy	Ensemble de flexible	Flexible, Conj.
14	1664405M1			2	Tie, Cable	Attache câble	Enlace de Cable
15	339229X1		M6 x 40	2	Screw	Vis	Tornillo
16	1462583M1			1	Plate	Plaque	Placa
17	6102170M1			1	Bracket, Clamp	Bride de fixation	Brida de fijación
18	6102170M1			1	Bracket, Clamp	Bride de fixation	Brida de fijación
19	339229X1		M6 x 40	2	Screw	Vis	Tornillo
20	1462583M1			1	Plate	Plaque	Placa
21	6102788M1			1	Bracket, Clamp	Bride de fixation	Brida de fijación
22	6102788M1			1	Bracket, Clamp	Bride de fixation	Brida de fijación



860 880 970 980
 TX870B TX970B

811 812 815 816 823 824 843 844 853 854 923 932

78013C01.1

6199042M3

1

Jan-06

Extendahoe Hydraulics
 Circuit Hydraulique Extendahoe
 Circuito hidráulico Extendahoe

Centremount
 Montage de Pelle Central
 Excavadora de montaje central

Control Pedal
 Pédale de Commande
 Pedal de control

C-78013-02.1-A

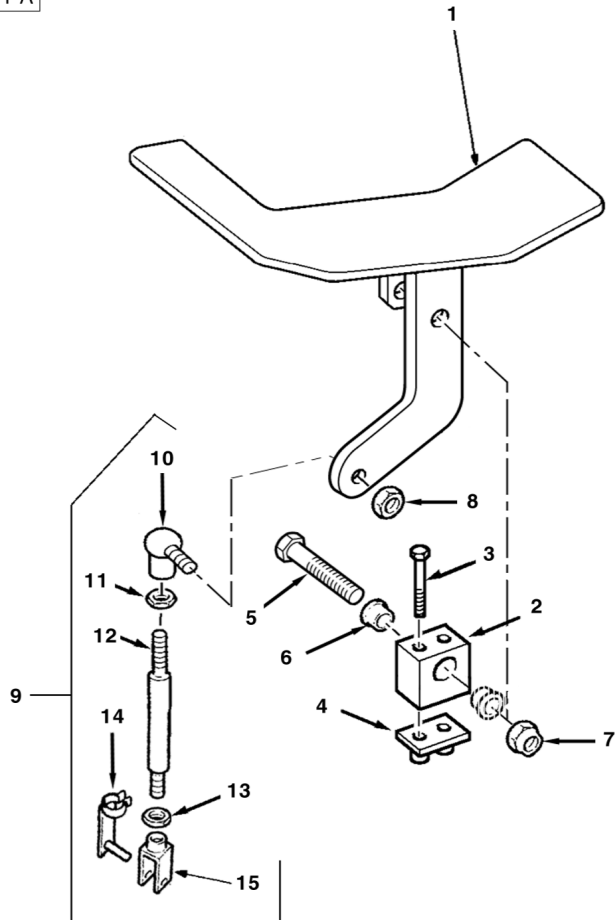

1	6106874M91		1	Pedal Assy	Ensemble de pédale	Pedal, Conj.
2	6106734M1		1	Pivot	Pivot	Pivote
3	3001758X1	M6 x 50	2	Screw	Vis	Tornillo
4	3519538M1		1	Plate, Base	Plaque de base	Placa de base
5	6106981M1	M10 x 60	1	Bolt	Boulon	Perno
6	6106866M1		2	Bushing	Bague	Anillo
7	1440329X1	M10	1	Nut, Lock	Écrou de blocage	Tuerca de retención
8	394367X1	M8	1	Nut, Lock	Écrou de blocage	Tuerca de retención
9	6106724M92		1	Rod Assy	Ensemble tringlerie	Tirantes, Conj.
10	3517518M1	9	1	Ball Joint	Rotule	Rotula
11	339169X1	9 M8	1	Nut	Écrou	Tuerca
12		9 Ref. 9	1	Rod	Tringle	Vástago
13	3519650M1	9 M8 LH Thread	1	Nut	Écrou	Tuerca
14	3520666M1	9	1	Pin, Clevis	Axe de chape	Eje de brida
15	3519590M1	9 LH Thread	1	Clevis	Chape	Brida
16	6101865M2		1	Decal	Adhésif	Adhesivo



860 880 970 980
 TX870B TX970B

811 812 815 816 823 824 843 844 853 854 923 932

78013C02.1

6199042M3

1

Jan-06

Extendahoe Hydraulics
Circuit Hydraulique Extendahoe
Circuito hidráulico Extendahoe

Centremount
Montage de Pelle Central
Excavadora de montaje central

With Auxiliary Hydraulics
 Avec Hydraulique Auxiliaire
 Con hidráulico auxiliar

4.5m
 4.5m
 4.5m

C-78014-01.1-A

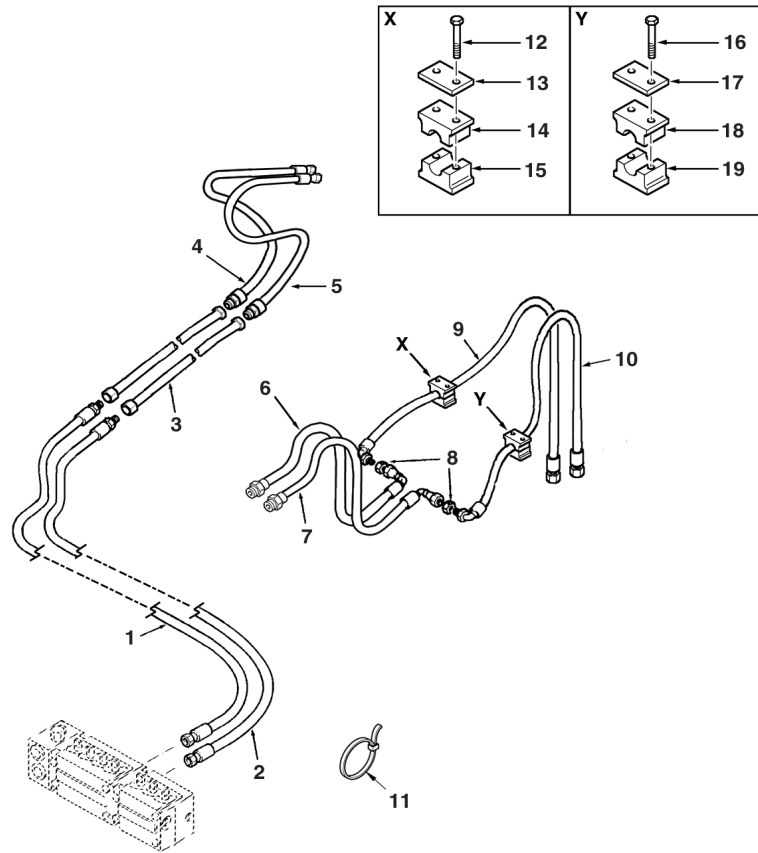

1	6107464M93	Dark Green	1	Hose Assy	Ensemble de flexible	Flexible, Conj.
2	6107465M92	Black	1	Hose Assy	Ensemble de flexible	Flexible, Conj.
3	6101773M91		2	Tube Assy	Tuyauterie	Conjunto de tubería
4	6101741M91	Dark Green	1	Hose Assy	Ensemble de flexible	Flexible, Conj.
5	6101757M91	Black	1	Hose Assy	Ensemble de flexible	Flexible, Conj.
6	6101739M91	Brown	1	Hose Assy	Ensemble de flexible	Flexible, Conj.
7	6101740M91	White	1	Hose Assy	Ensemble de flexible	Flexible, Conj.
8	355574X1		2	Nut	Écrou	Tuerca
9	6101007M91	Brown	1	Hose Assy	Ensemble de flexible	Flexible, Conj.
10	6101008M91	White	1	Hose Assy	Ensemble de flexible	Flexible, Conj.
11	1664405M1		2	Tie, Cable	Attache câble	Enlace de Cable
12	339229X1	M6 x 40	2	Screw	Vis	Tornillo
13	1462583M1		1	Plate	Plaque	Placa
14	6102170M1		1	Bracket, Clamp	Bride de fixation	Brida de fijación
15	6102170M1		1	Bracket, Clamp	Bride de fixation	Brida de fijación
16	339229X1	M6 x 40	2	Screw	Vis	Tornillo
17	1462583M1		1	Plate	Plaque	Placa
18	6102788M1		1	Bracket, Clamp	Bride de fixation	Brida de fijación
19	6102788M1		1	Bracket, Clamp	Bride de fixation	Brida de fijación



820 860 880 970
 TX760B TX860B

801 802 803 804 809 810 813 814 821 822 831 832 841 842 851 852 922

78014C01.1

6199042M3

1

Jan-06

Extendahoe Hydraulics
 Circuit Hydraulique Extendahoe
 Circuito hidráulico Extendahoe

Centremount
 Montage de Pelle Central
 Excavadora de montaje central

Control Pedal
 Pédale de Commande
 Pedal de control

C-78014-02.1-A

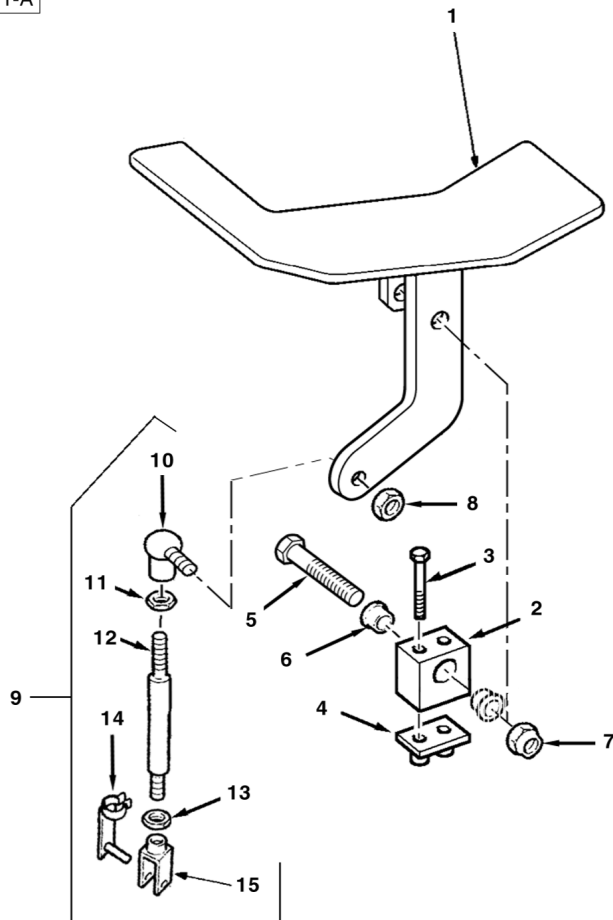

1	6106874M91		1	Pedal Assy	Ensemble de pédale	Pedal, Conj.
2	6106734M1		1	Pivot	Pivot	Pivote
3	3001758X1	M6 x 50	2	Screw	Vis	Tornillo
4	3519538M1		1	Plate, Base	Plaque de base	Placa de base
5	6106981M1	M10 x 60	1	Bolt	Boulon	Perno
6	6106866M1		2	Bushing	Bague	Anillo
7	1440329X1	M10	1	Nut, Lock	Écrou de blocage	Tuerca de retención
8	394367X1	M8	1	Nut, Lock	Écrou de blocage	Tuerca de retención
9	6106724M92		1	Rod Assy	Ensemble tringlerie	Tirantes, Conj.
10	3517518M1	9	1	Ball Joint	Rotule	Rotula
11	339169X1	9 M8	1	Nut	Écrou	Tuerca
12		9 Ref. 9	1	Rod	Tringle	Vástago
13	3519650M1	9 M8 LH Thread	1	Nut	Écrou	Tuerca
14	3520666M1	9	1	Pin, Clevis	Axe de chape	Eje de brida
15	3519590M1	9 LH Thread	1	Clevis	Chape	Brida
16	6101865M2		1	Decal	Adhésif	Adhesivo



820 860 880 970
 TX760B TX860B

801 802 803 804 809 810 813 814 821 822 831 832 841 842 851 852 922

78014C02.1

6199042M3

1

Jan-06

Extendahoe Hydraulics
Circuit Hydraulique Extendahoe
Circuito hidráulico Extendahoe

Centremount
Montage de Pelle Central
Excavadora de montaje central

With Auxiliary Hydraulics
Avec Hydraulique Auxiliaire
Con hidraulico auxiliar

4.9m
 4.9m
 4.9m

C-78015-01.1-A

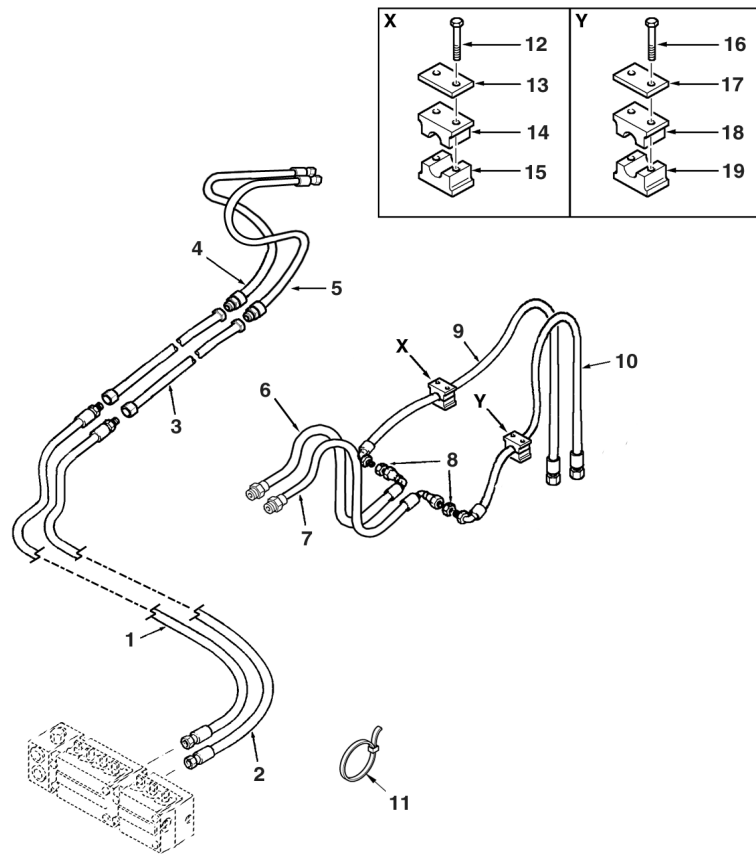

1	6107464M93	Dark Green	1	Hose Assy	Ensemble de flexible	Flexible, Conj.
2	6107465M92	Black	1	Hose Assy	Ensemble de flexible	Flexible, Conj.
3	6101734M91		2	Tube Assy	Tuyauterie	Conjunto de tubería
4	6101741M91	Dark Green	1	Hose Assy	Ensemble de flexible	Flexible, Conj.
5	6101757M91	Black	1	Hose Assy	Ensemble de flexible	Flexible, Conj.
6	6101739M91	Brown	1	Hose Assy	Ensemble de flexible	Flexible, Conj.
7	6101740M91	White	1	Hose Assy	Ensemble de flexible	Flexible, Conj.
8	355574X1		2	Nut	Écrou	Tuerca
9	6101007M91	Brown	1	Hose Assy	Ensemble de flexible	Flexible, Conj.
10	6101008M91	White	1	Hose Assy	Ensemble de flexible	Flexible, Conj.
11	1664405M1		2	Tie, Cable	Attache câble	Enlace de Cable
12	339229X1	M6 x 40	2	Screw	Vis	Tornillo
13	1462583M1		1	Plate	Plaque	Placa
14	6102170M1		1	Bracket, Clamp	Bride de fixation	Brida de fijación
15	6102170M1		1	Bracket, Clamp	Bride de fixation	Brida de fijación
16	339229X1	M6 x 40	2	Screw	Vis	Tornillo
17	1462583M1		1	Plate	Plaque	Placa
18	6102788M1		1	Bracket, Clamp	Bride de fixation	Brida de fijación
19	6102788M1		1	Bracket, Clamp	Bride de fixation	Brida de fijación



860 880 970 980
 TX870B TX970B

811 812 815 816 823 824 843 844 853 854 923 932

78015C01.1

6199042M3

1

Jan-06

Extendahoe Hydraulics
 Circuit Hydraulique Extendahoe
 Circuito hidráulico Extendahoe

Centremount
 Montage de Pelle Central
 Excavadora de montaje central

Control Pedal
 Pédale de Commande
 Pedal de control

C-78015-02.1-A

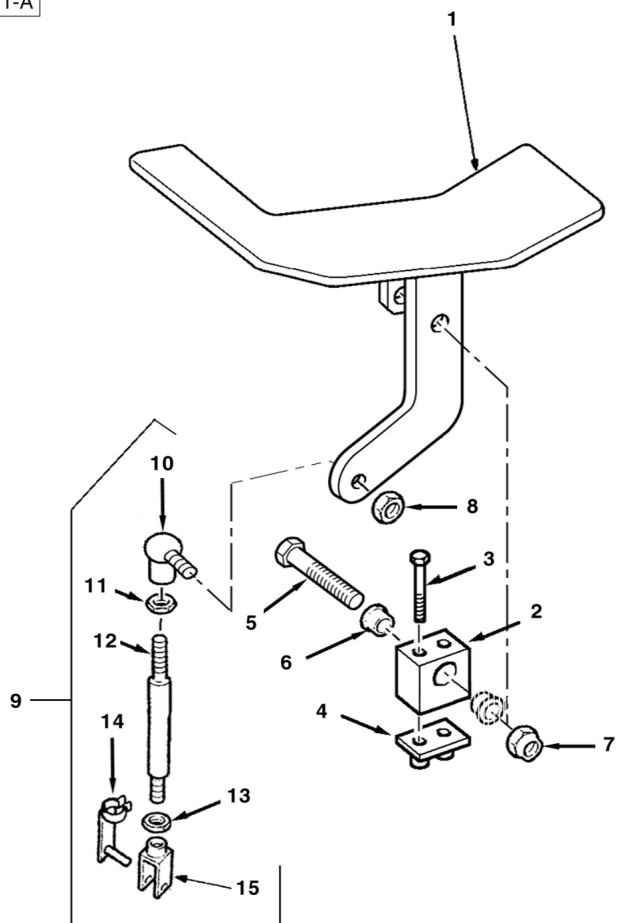

1	6106874M91		1	Pedal Assy	Ensemble de pédale	Pedal, Conj.
2	6106734M1		1	Pivot	Pivot	Pivote
3	3001758X1	M6 x 50	2	Screw	Vis	Tornillo
4	3519538M1		1	Plate, Base	Plaque de base	Placa de base
5	6106981M1	M10 x 60	1	Bolt	Boulon	Perno
6	6106866M1		2	Bushing	Bague	Anillo
7	1440329X1	M10	1	Nut, Lock	Écrou de blocage	Tuerca de retención
8	394367X1	M8	1	Nut, Lock	Écrou de blocage	Tuerca de retención
9	6106724M92		1	Rod Assy	Ensemble tringlerie	Tirantes, Conj.
10	3517518M1	9	1	Ball Joint	Rotule	Rotula
11	339169X1	9 M8	1	Nut	Écrou	Tuerca
12		9 Ref. 9	1	Rod	Tringle	Vástago
13	3519650M1	9 M8 LH Thread	1	Nut	Écrou	Tuerca
14	3520666M1	9	1	Pin, Clevis	Axe de chape	Eje de brida
15	3519590M1	9 LH Thread	1	Clevis	Chape	Brida
16	6101865M2		1	Decal	Adhésif	Adhesivo



860 880 970 980
 TX870B TX970B

811 812 815 816 823 824 843 844 853 854 923 932

78015C02.1

6199042M3

1

Jan-06

Extendahoe Hydraulics
Circuit Hydraulique Extendahoe
Circuito hidráulico Extendahoe

Sideshift
Montage de Pelle Latéral
Excavadora de montaje horizontal

Without Auxiliary Hydraulics
Sans Hydraulique Auxiliaire
Sin hidraulico auxiliar

C-78010-01.1-A

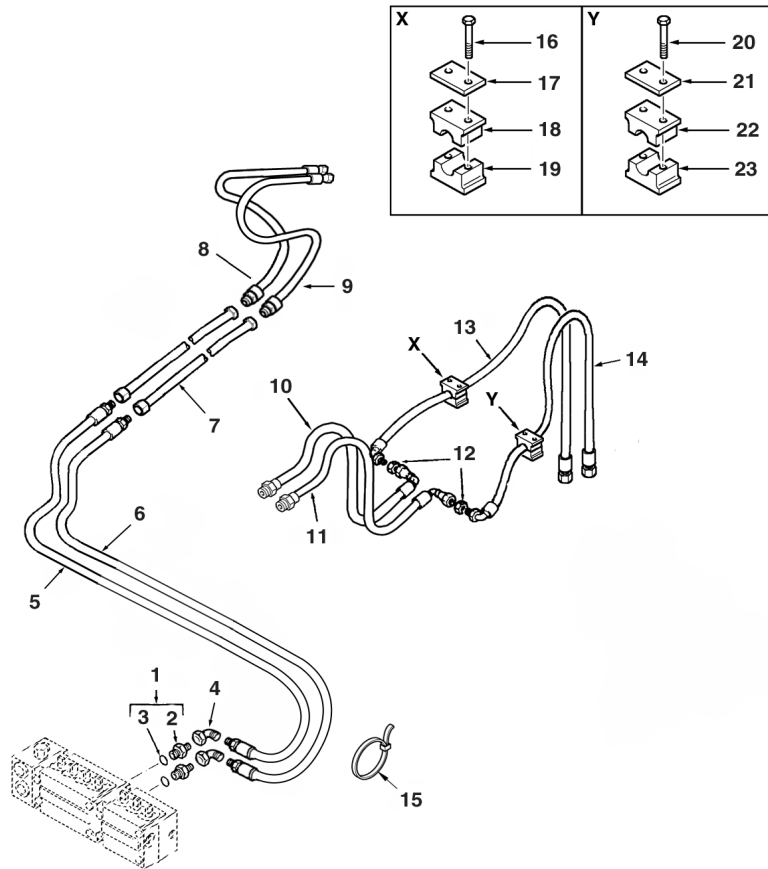

1	365715X91		1, 1/16" - 7/8" UNF	2	Connector Assy	Ensemble connexion	Conexión, Conj.
2		1	Ref. 1	1	Connector	Connecteur	Conector
3	835025M1	1		1	O-Ring	Joint torique	Junta de tipo O
4	373784X1			2	Elbow	Coude	Codo
5	6108764M91			1	Hose Assy	Ensemble de flexible	Flexible, Conj.
6	6108765M91			1	Hose Assy	Ensemble de flexible	Flexible, Conj.
7	6101773M91			2	Tube Assy	Tuyauterie	Conjunto de tubería
8	6101741M91		Dark Green	1	Hose Assy	Ensemble de flexible	Flexible, Conj.
9	6101757M91		Black	1	Hose Assy	Ensemble de flexible	Flexible, Conj.
10	6101739M91		Brown	1	Hose Assy	Ensemble de flexible	Flexible, Conj.
11	6101740M91		White	1	Hose Assy	Ensemble de flexible	Flexible, Conj.
12	355574X1			2	Nut	Écrou	Tuerca
13	6101007M91		Brown	1	Hose Assy	Ensemble de flexible	Flexible, Conj.
14	6101008M91		White	1	Hose Assy	Ensemble de flexible	Flexible, Conj.
15	1664405M1			2	Tie, Cable	Attache câble	Enlace de Cable
16	339229X1		M6 x 40	2	Screw	Vis	Tornillo
17	1462583M1			1	Plate	Plaque	Placa
18	6102170M1			1	Bracket, Clamp	Bride de fixation	Brida de fijación
19	6102170M1			1	Bracket, Clamp	Bride de fixation	Brida de fijación
20	339229X1		M6 x 40	2	Screw	Vis	Tornillo
21	1462583M1			1	Plate	Plaque	Placa
22	6102788M1			1	Bracket, Clamp	Bride de fixation	Brida de fijación
23	6102788M1			1	Bracket, Clamp	Bride de fixation	Brida de fijación



820 860 880 970 980
 TX760B TX860B

805 806 807 808 817 825 831 832 833 834 845 855 921 931

78010C01.1

6199042M3

1

Jan-06

Extendahoe Hydraulics
 Circuit Hydraulique Extendahoe
 Circuito hidráulico Extendahoe

Sideshift
 Montage de Pelle Latéral
 Excavadora de montaje horizontal

Control Pedal
 Pédale de Commande
 Pedal de control

C-78010-02.1-A

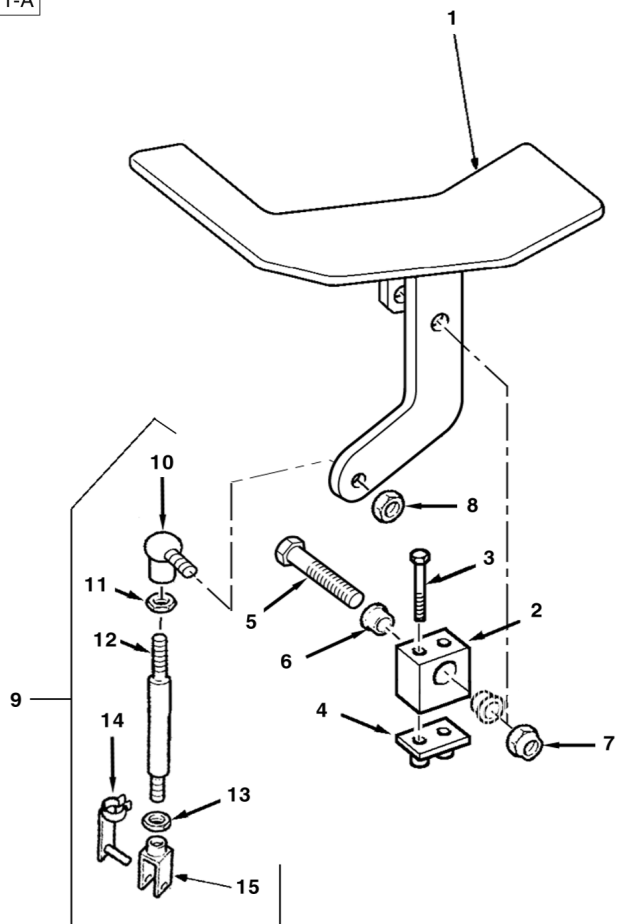

1	6106874M91		1	Pedal Assy	Ensemble de pédale	Pedal, Conj.
2	6106734M1		1	Pivot	Pivot	Pivote
3	3001758X1	M6 x 50	2	Screw	Vis	Tornillo
4	3519538M1		1	Plate, Base	Plaque de base	Placa de base
5	6106981M1	M10 x 60	1	Bolt	Boulon	Perno
6	6106866M1		2	Bushing	Bague	Anillo
7	1440329X1	M10	1	Nut, Lock	Écrou de blocage	Tuerca de retención
8	394367X1	M8	1	Nut, Lock	Écrou de blocage	Tuerca de retención
9	6106724M92		1	Rod Assy	Ensemble tringlerie	Tirantes, Conj.
10	3517518M1	9	1	Ball Joint	Rotule	Rotula
11	339169X1	9 M8	1	Nut	Écrou	Tuerca
12		9 Ref. 9	1	Rod	Tringle	Vástago
13	3519650M1	9 M8 LH Thread	1	Nut	Écrou	Tuerca
14	3520666M1	9	1	Pin, Clevis	Axe de chape	Eje de brida
15	3519590M1	9 LH Thread	1	Clevis	Chape	Brida
16	6101865M2		1	Decal	Adhésif	Adhesivo



820 860 880 970 980
 TX760B TX860B

805 806 807 808 817 825 831 832 833 834 845 855 921 931

78010C02.1

6199042M3

1

Jan-06

Extendahoe Hydraulics
Circuit Hydraulique Extendahoe
Circuito hidráulico Extendahoe

Sideshift
Montage de Pelle Latéral
Excavadora de montaje horizontal

With Auxiliary Hydraulics
Avec Hydraulique Auxiliaire
Con hidraulico auxiliar

C-78011-01.1-A

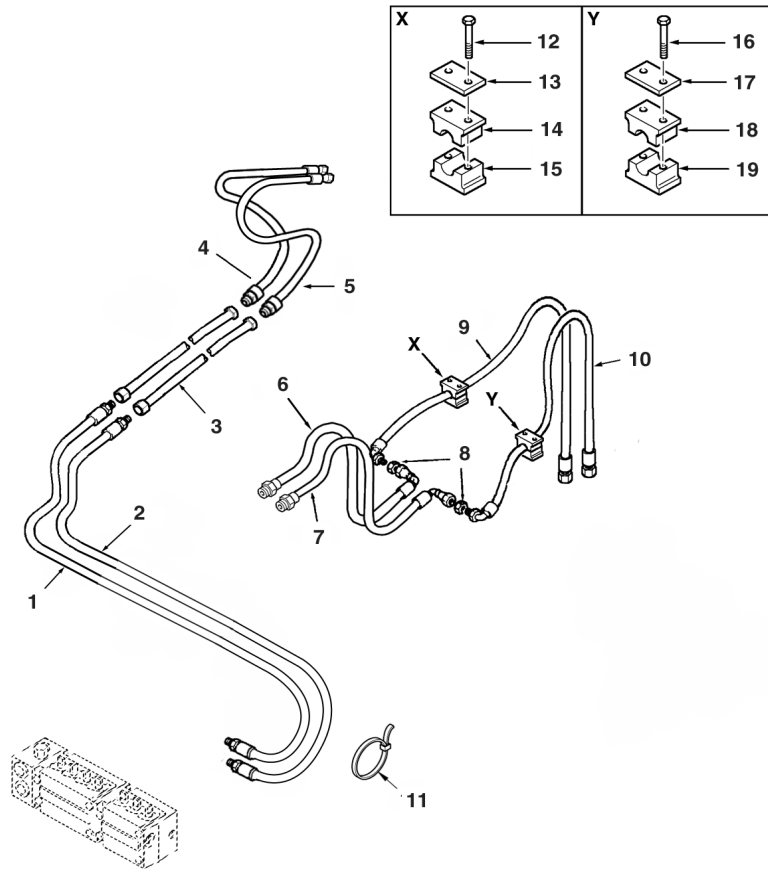

1	6108764M91		1	Hose Assy	Ensemble de flexible	Flexible, Conj.
2	6108765M91		1	Hose Assy	Ensemble de flexible	Flexible, Conj.
3	6101773M91		2	Tube Assy	Tuyauterie	Conjunto de tubería
4	6101741M91	Dark Green	1	Hose Assy	Ensemble de flexible	Flexible, Conj.
5	6101757M91	Black	1	Hose Assy	Ensemble de flexible	Flexible, Conj.
6	6101739M91	Brown	1	Hose Assy	Ensemble de flexible	Flexible, Conj.
7	6101740M91	White	1	Hose Assy	Ensemble de flexible	Flexible, Conj.
8	355574X1		2	Nut	Écrou	Tuerca
9	6101007M91	Brown	1	Hose Assy	Ensemble de flexible	Flexible, Conj.
10	6101008M91	White	1	Hose Assy	Ensemble de flexible	Flexible, Conj.
11	1664405M1		X	Tie, Cable	Attache câble	Enlace de Cable
12	339229X1	M6 x 40	2	Screw	Vis	Tornillo
13	1462583M1		1	Plate	Plaque	Placa
14	6102170M1		1	Bracket, Clamp	Bride de fixation	Brida de fijación
15	6102170M1		1	Bracket, Clamp	Bride de fixation	Brida de fijación
16	339229X1	M6 x 40	2	Screw	Vis	Tornillo
17	1462583M1		1	Plate	Plaque	Placa
18	6102788M1		1	Bracket, Clamp	Bride de fixation	Brida de fijación
19	6102788M1		1	Bracket, Clamp	Bride de fixation	Brida de fijación



820 860 880 970 980
 TX760B TX860B

805 806 807 808 817 825 831 832 833 834 845 855 921 931

78011C01.1

6199042M3

1

Jan-06

Extendahoe Hydraulics
 Circuit Hydraulique Extendahoe
 Circuito hidráulico Extendahoe

Sideshift
 Montage de Pelle Latéral
 Excavadora de montaje horizontal

Control Pedal
 Pédale de Commande
 Pedal de control

C-78011-02.1-A

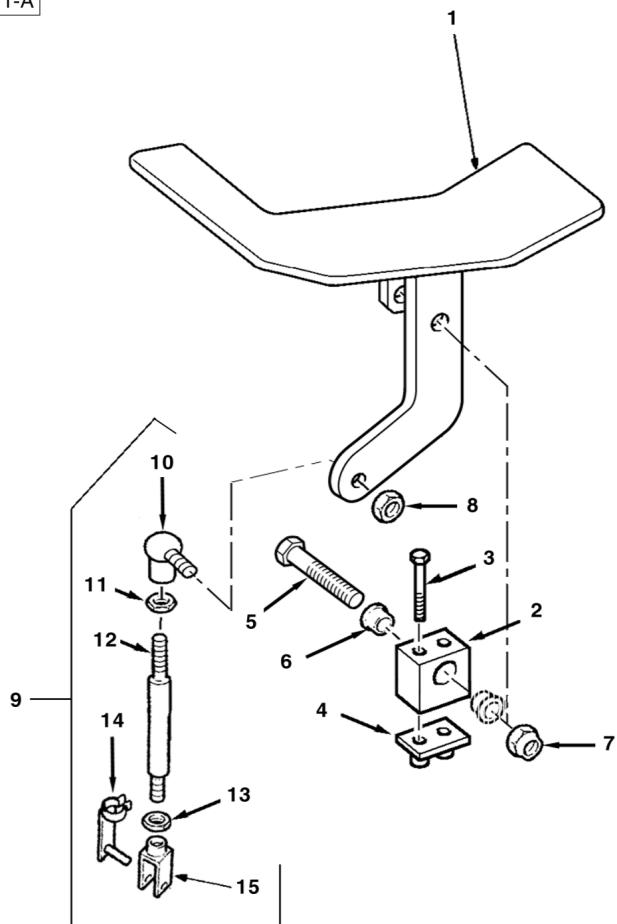

1	6106874M91		1	Pedal Assy	Ensemble de pédale	Pedal, Conj.
2	6106734M1		1	Pivot	Pivot	Pivote
3	3001758X1	M6 x 50	2	Screw	Vis	Tornillo
4	3519538M1		1	Plate, Base	Plaque de base	Placa de base
5	6106981M1	M10 x 60	1	Bolt	Boulon	Perno
6	6106866M1		2	Bushing	Bague	Anillo
7	1440329X1	M10	1	Nut, Lock	Écrou de blocage	Tuerca de retención
8	394367X1	M8	1	Nut, Lock	Écrou de blocage	Tuerca de retención
9	6106724M92		1	Rod Assy	Ensemble tringlerie	Tirantes, Conj.
10	3517518M1	9	1	Ball Joint	Rotule	Rotula
11	339169X1	9 M8	1	Nut	Écrou	Tuerca
12		9 Ref.9	1	Rod	Tringle	Vástago
13	3519650M1	9 M8 LH Thread	1	Nut	Écrou	Tuerca
14	3520666M1	9	1	Pin, Clevis	Axe de chape	Eje de brida
15	3519590M1	9 LH Thread	1	Clevis	Chape	Brida
16	6101865M2		1	Decal	Adhésif	Adhesivo



820 860 880 970 980
 TX760B TX860B

805 806 807 808 817 825 831 832 833 834 845 855 921 931

78011C02.1

6199042M3

1

Jan-06

Hydraulic Reservoir
Réservoir Hydraulique
Depósito hidráulico

Synchro Shuttle
 Synchro Shuttle
 Synchro Shuttle

C-40001-05.1-B

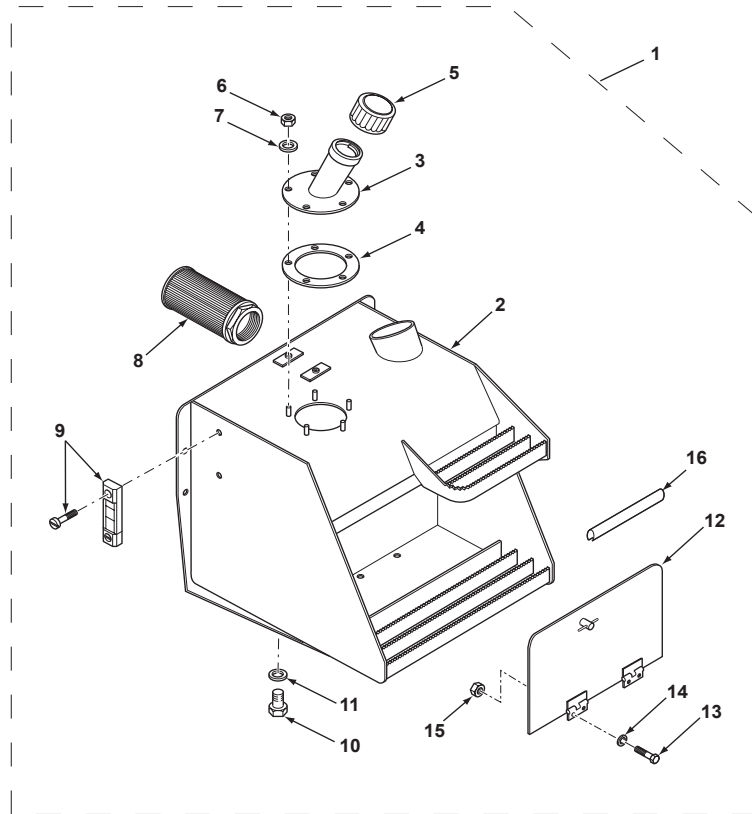

1	6108959M94		40001C01.1 30	1	Reservoir Assy	Ensemble de réservoir	Depósito, Conj.
2		1	Ref.1	1	Reservoir	Réservoir	Depósito
3	6109321M93	1		1	Filler	Remplisseur	Rellenador
4	6110441M1	1		1	Gasket	Joint	Empaquetadura
5	6109794M1	1		1	Breather	Reniflard	Ventilador del cárter
6	339169X1	1	M8	5	Nut	Écrou	Tuerca
7	339374X1	1	M8	5	Washer, Lock	Rondelle de blocage	Arandela de freno
8	3515254M1	1		1	Filter, Oil	Filtre à huile	Filtro de aceite
9	3516190M91	1		1	Gauge, Sight	Indicateur de niveau	Indicador de nivel
10	376501X1	1		1	Plug, Drain	Bouchon de vidange	Tapón de drenaje
11	1476281X1	1		1	Ring, Packing	Rondelle joint	Arandela junta
12	6109796M91	1		1	Cover Assy	Ensemble de couvercle	Tapa, Conj.
13	339666X1	1	M6 x 20	4	Screw	Vis	Tornillo
14	390971X1	1	M6	4	Washer	Rondelle	Arandela
15	1441500X1	1	M6	4	Nut, Lock	Écrou de blocage	Tuerca de retención
16	6110594M1	1		2	Trim	Bande	Banda



820
TX760B

801 802 803 804 805 806 807 808 831 832 833 834

40001C05.1

6199042M3

1

Jan-06

Hydraulic Reservoir
Réservoir Hydraulique
Depósito hidráulico

Synchro Shuttle
 Synchro Shuttle
 Synchro Shuttle

C-40002-05.1-B

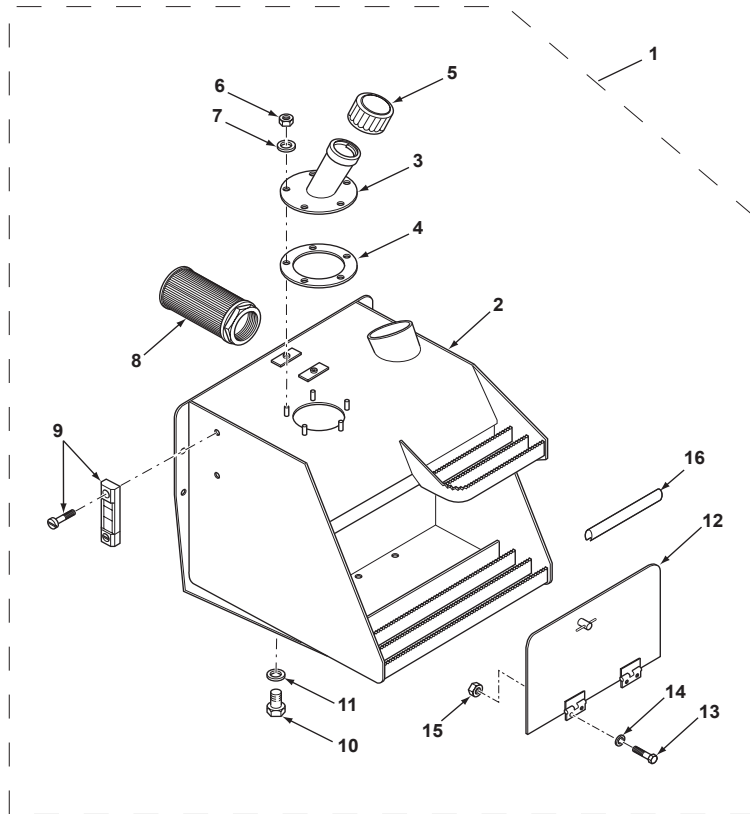

1	6108959M94		40002C01.1 30	1	Reservoir Assy	Ensemble de réservoir	Depósito, Conj.
2		1	Ref.1	1	Reservoir	Réservoir	Depósito
3	6109321M93	1		1	Filler	Remplisseur	Rellenador
4	6110441M1	1		1	Gasket	Joint	Empaquetadura
5	6109794M1	1		1	Breather	Reniflard	Ventilador del cárter
6	339169X1	1	M8	5	Nut	Écrou	Tuerca
7	339374X1	1	M8	5	Washer, Lock	Rondelle de blocage	Arandela de freno
8	3515254M1	1		1	Filter, Oil	Filtre à huile	Filtro de aceite
9	3516190M91	1		1	Gauge, Sight	Indicateur de niveau	Indicador de nivel
10	376501X1	1		1	Plug, Drain	Bouchon de vidange	Tapón de drenaje
11	1476281X1	1		1	Ring, Packing	Rondelle joint	Arandela junta
12	6109796M91	1		1	Cover Assy	Ensemble de couvercle	Tapa, Conj.
13	339666X1	1	M6 x 20	4	Screw	Vis	Tornillo
14	390971X1	1	M6	4	Washer	Rondelle	Arandela
15	1441500X1	1	M6	4	Nut, Lock	Écrou de blocage	Tuerca de retención
16	6110594M1	1		2	Trim	Bande	Banda



860 880
 TX860B TX870B

809 810 811 812 813 814 815 816 817 841 842 843 844 845

40002C05.1

6199042M3

1

Jan-06

Hydraulic Reservoir
Réservoir Hydraulique
Depósito hidráulico

Powershift
 Powershift
 Powershift

C-40003-05.1-B

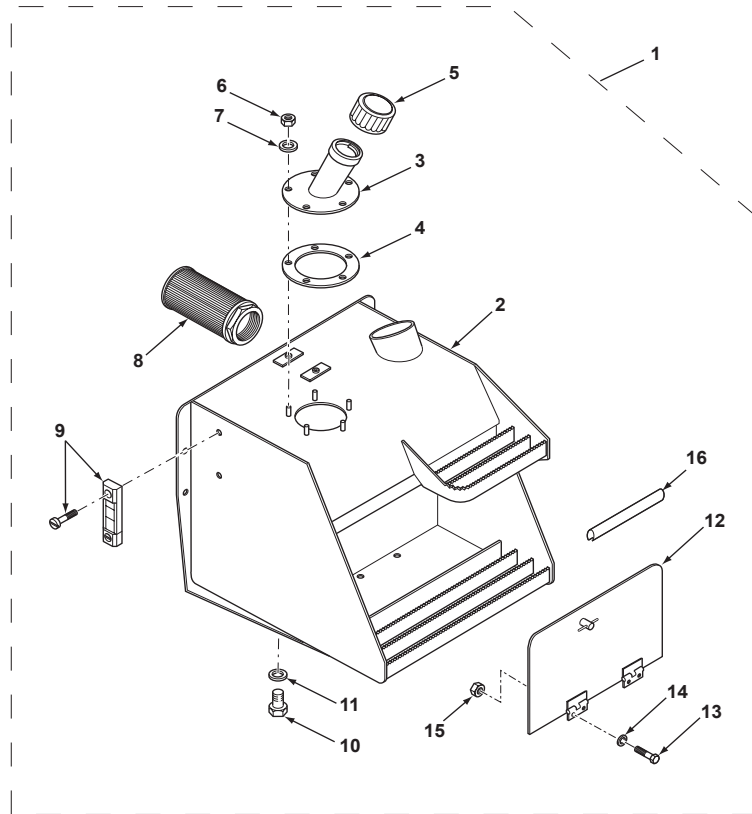

1	6108959M94		40003C01.1 30	1	Reservoir Assy	Ensemble de réservoir	Depósito, Conj.
2		1	Ref.1	1	Reservoir	Réservoir	Depósito
3	6109321M93	1		1	Filler	Remplisseur	Rellenador
4	6110441M1	1		1	Gasket	Joint	Empaquetadura
5	6109794M1	1		1	Breather	Reniflard	Ventilador del cárter
6	339169X1	1	M8	5	Nut	Écrou	Tuerca
7	339374X1	1	M8	5	Washer, Lock	Rondelle de blocage	Arandela de freno
8	3515254M1	1		1	Filter, Oil	Filtre à huile	Filtro de aceite
9	3516190M91	1		1	Gauge, Sight	Indicateur de niveau	Indicador de nivel
10	376501X1	1		1	Plug, Drain	Bouchon de vidange	Tapón de drenaje
11	1476281X1	1		1	Ring, Packing	Rondelle joint	Arandela junta
12	6109796M91	1		1	Cover Assy	Ensemble de couvercle	Tapa, Conj.
13	339666X1	1	M6 x 20	4	Screw	Vis	Tornillo
14	390971X1	1	M6	4	Washer	Rondelle	Arandela
15	1441500X1	1	M6	4	Nut, Lock	Écrou de blocage	Tuerca de retención
16	6110594M1	1		2	Trim	Bande	Banda



860 880 970 980
 TX860B TX870B
 TX970B

821 822 823 824 825 851 852 853 854 855 921 922 923 931 932

40003C05.1

6199042M3

1

Jan-06

Hydraulic Reservoir
Réservoir Hydraulique
Depósito hidráulico

Synchro Shuttle
 Synchro Shuttle
 Synchro Shuttle

C-40004-05.1-B

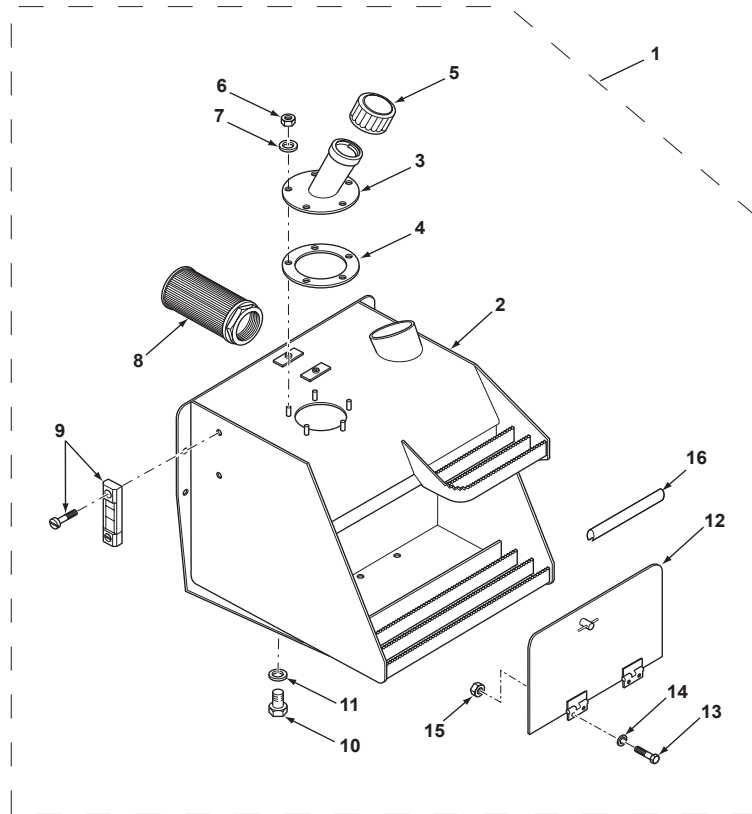

1	6108959M94		40004C01.1 30	1	Reservoir Assy	Ensemble de réservoir	Depósito, Conj.
2		1	Ref.1	1	Reservoir	Réservoir	Depósito
3	6109321M93	1		1	Filler	Remplisseur	Rellenador
4	6110441M1	1		1	Gasket	Joint	Empaquetadura
5	6109794M1	1		1	Breather	Reniflard	Ventilador del cárter
6	339169X1	1	M8	5	Nut	Écrou	Tuerca
7	339374X1	1	M8	5	Washer, Lock	Rondelle de blocage	Arandela de freno
8	3515254M1	1		1	Filter, Oil	Filtre à huile	Filtro de aceite
9	3516190M91	1		1	Gauge, Sight	Indicateur de niveau	Indicador de nivel
10	376501X1	1		1	Plug, Drain	Bouchon de vidange	Tapón de drenaje
11	1476281X1	1		1	Ring, Packing	Rondelle joint	Arandela junta
12	6109796M91	1		1	Cover Assy	Ensemble de couvercle	Tapa, Conj.
13	339666X1	1	M6 x 20	4	Screw	Vis	Tornillo
14	390971X1	1	M6	4	Washer	Rondelle	Arandela
15	1441500X1	1	M6	4	Nut, Lock	Écrou de blocage	Tuerca de retención
16	6110594M1	1		2	Trim	Bande	Banda



860 880
 TX860B TX870B

817 841 842 843 844 845

40004C05.1

6199042M3

1

Jan-06

Hydraulic Reservoir
Réservoir Hydraulique
Depósito hidráulico

Synchro Shuttle
 Synchro Shuttle
 Synchro Shuttle

C-40005-05.1-A

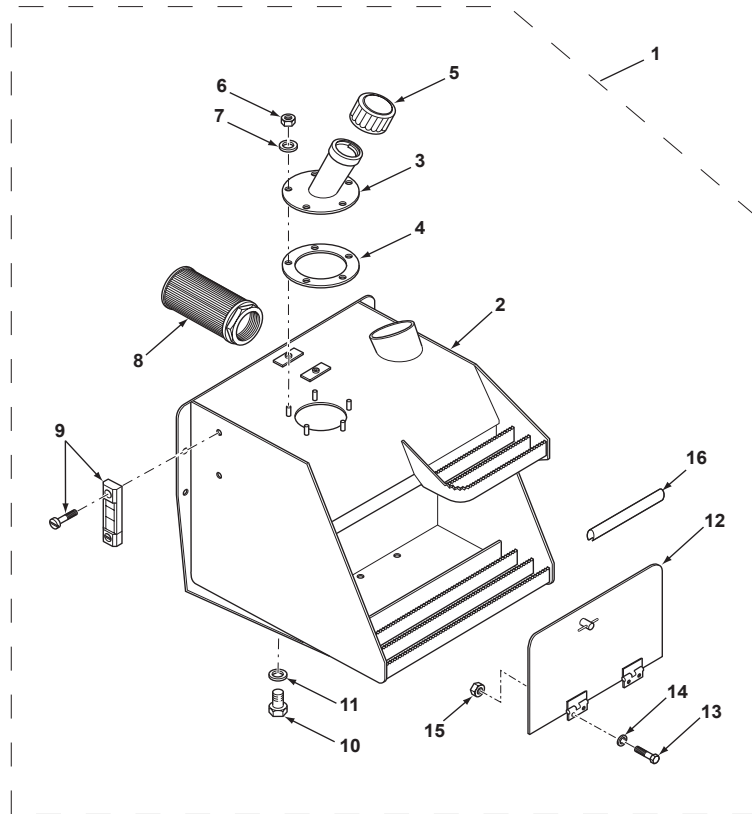

1	6108959M94		40005C01.1 30	1	Reservoir Assy	Ensemble de réservoir	Depósito, Conj.
2		1	Ref.1	1	Reservoir	Réservoir	Depósito
3	6109321M93	1		1	Filler	Remplisseur	Rellenador
4	6110441M1	1		1	Gasket	Joint	Empaquetadura
5	6109794M1	1		1	Breather	Reniflard	Ventilador del cárter
6	339169X1	1	M8	5	Nut	Écrou	Tuerca
7	339374X1	1	M8	5	Washer, Lock	Rondelle de blocage	Arandela de freno
8	3515254M1	1		1	Filter, Oil	Filtre à huile	Filtro de aceite
9	3516190M91	1		1	Gauge, Sight	Indicateur de niveau	Indicador de nivel
10	376501X1	1		1	Plug, Drain	Bouchon de vidange	Tapón de drenaje
11	1476281X1	1		1	Ring, Packing	Rondelle joint	Arandela junta
12	6109796M91	1		1	Cover Assy	Ensemble de couvercle	Tapa, Conj.
13	339666X1	1	M6 x 20	4	Screw	Vis	Tornillo
14	390971X1	1	M6	4	Washer	Rondelle	Arandela
15	1441500X1	1	M6	4	Nut, Lock	Écrou de blocage	Tuerca de retención
16	6110594M1	1		2	Trim	Bande	Banda



820
TX760B

803 804 807 808 831

40005C05.1

6199042M3

1

Jan-06

Hydraulic Valve
Distributeur de Commande Hydraulique
Distribuidor de mando hidráulico

Backhoe Control
Godet Rétro
Equipo retro

Sideshift digger installation
 Installation montage de pelle latéral
 La Instalación excavadora de montaje horizontal

C-38001-01.1-A

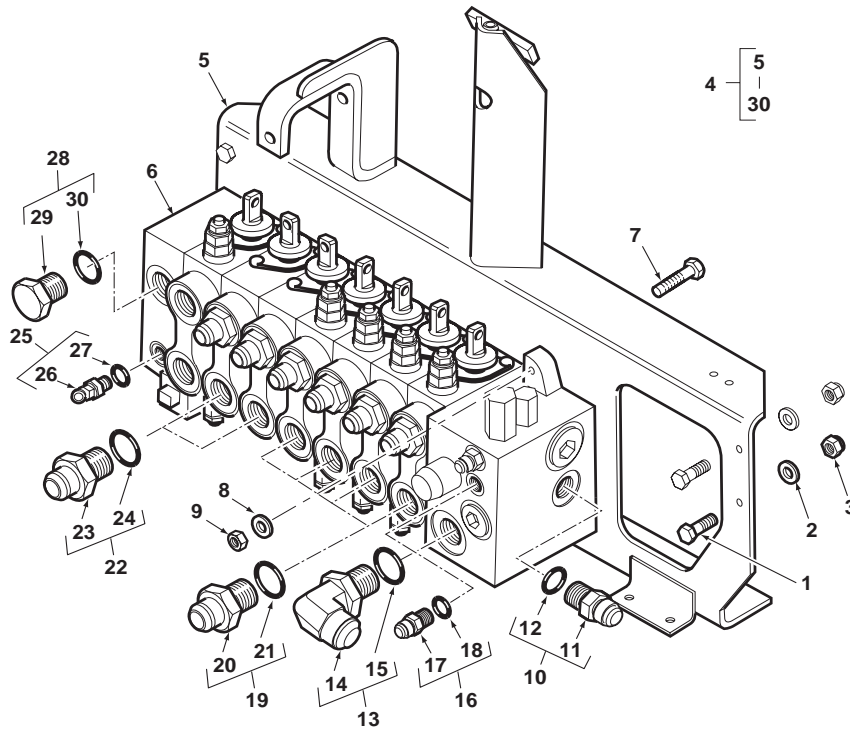

1	3009493X1	M10 x 30	4	Bolt	Boulon	Perno
2	385362X1	M10	4	Washer	Rondelle	Arandela
3	1440329X1	M10	4	Nut, Lock	Écrou de blocage	Tuerca de retención
4	6109327M91	(A)	1	Valve Assy, Control	Ensemble distribution	Distribuidor, Conj.
5	6109344M92	4	1	Bracket Assy	Ensemble chaise palier	Cuchara, Conj.
6	6109206M91	4	1	Valve Assy, Control	Ensemble distribution	Distribuidor, Conj.
7	3009496X1	4 M10 x 45	3	Screw	Vis	Tornillo
8	385362X1	4 M10	3	Washer	Rondelle	Arandela
9	1440329X1	4 M10	3	Nut, Lock	Écrou de blocage	Tuerca de retención
10	835057M91	4	1	Connector Assy	Ensemble connexion	Conexión, Conj.
11	10	➡ Ref. 10	1	Union	Union	Unión
12	835025M1	10	1	O-Ring	Joint torique	Junta de tipo O
13	358766X91	4	1	Elbow, 90°	Coude à 90°	Codo, 90°
14	13	➡ Ref. 13	1	Elbow	Coude	Codo
15	835026M1	13	1	O-Ring	Joint torique	Junta de tipo O
16	835091M91	4 9/16	2	Union	Union	Unión
17	16	➡ Ref. 16	1	O-Ring	Union	Unión
18	831452M1	16	1	O-Ring	Joint torique	Junta de tipo O
19	365715X91	4 1,1/16" - 7/8" UNF	8	Connector Assy	Ensemble connexion	Conexión, Conj.
20	19	➡ Ref. 19	1	Union	Union	Unión
21	835025M1	19	1	O-Ring	Joint torique	Junta de tipo O
22	365713X91	4	4	Union	Union	Unión
23	22	➡ Ref. 22	1	O-Ring	Union	Unión
24	835025M1	22	1	O-Ring	Joint torique	Junta de tipo O
25	358781X91	4	1	Elbow, 45°	Coude à 45°	Codo, 45°
26	25	➡ Ref. 25	1	Elbow	Coude	Codo
27	831452M1	25	1	O-Ring	Joint torique	Junta de tipo O
28	835099M91	4	1	Plug Assy	Ensemble bouchons	Tapón, Conj.
29	28	➡ Ref. 28	1	Plug	Bouchon	Tapón
30	835025M1	28	1	O-Ring	Joint torique	Junta de tipo O

A With Auxiliary Hydraulics
 Avec Hydraulique Auxiliaire
 Con hidraulico auxiliar



860
TX860B

825

38001C01.1

6199042M3

1

Jan-06

Hydraulic Valve
Distributeur de Commande Hydraulique
Distribuidor de mando hidráulico

Backhoe Control
Godet Rétro
Equipo retro

Inlet
Admission
Admisión

Sideshift digger
Sideshift digger
Sideshift digger

C-38001-02.1-A

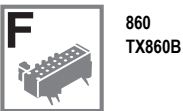
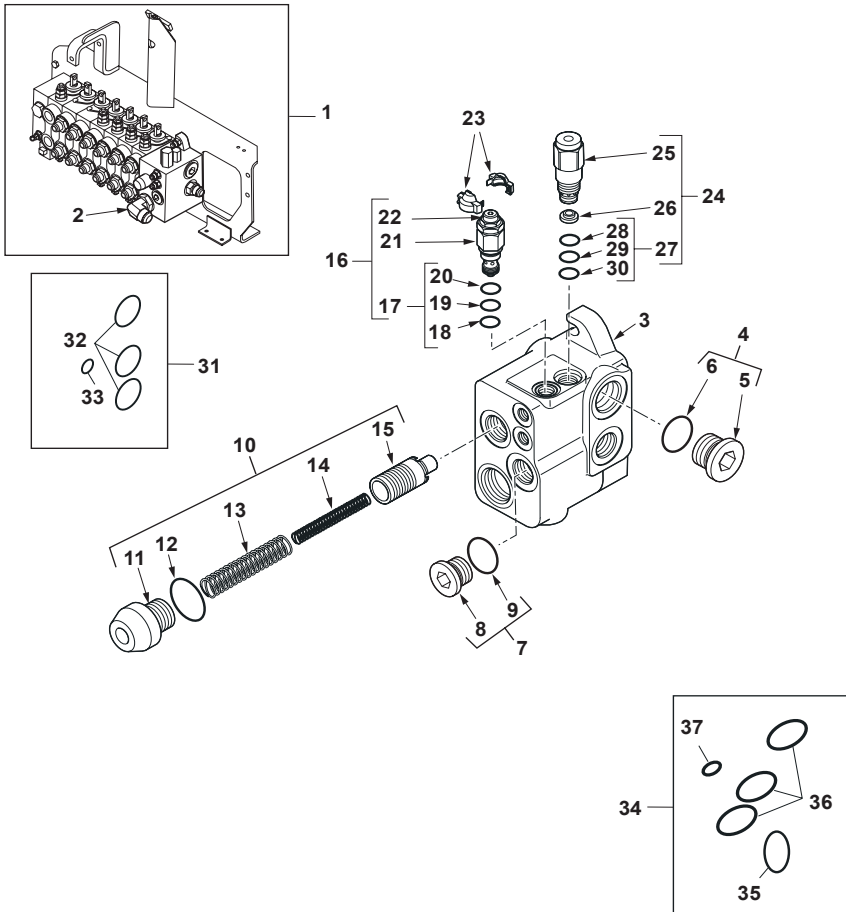

825

1	6109206M91		1	Valve Assy, Control	Ensemble distribution	Distribuidor, Conj.
2		1 (C)Inlet	1	Valve Assy	Ensemble de soupape	Válvula, Conj.
3		2 Ref. 2	1	Body	Corps	Cuerpo
4	6193772M91	2 5/16" UNF	1	Plug Assy	Ensemble bouchons	Tapón, Conj.
5		4 Ref. 4	1	Plug	Bouchon	Tapón
6		4 Ref. 4	1	O-Ring	Joint torique	Junta de tipo O
7	6193773M91	2 1 1/16" UNF	1	Plug Assy	Ensemble bouchons	Tapón, Conj.
8		7 Ref. 7	1	Plug	Bouchon	Tapón
9		7 Ref. 7	1	O-Ring	Joint torique	Junta de tipo O
10	6193786M91	2	1	Valve Assy, Pressure	Ens. soupape pression	Válvula presión, Conj.
11		10 Ref. 10	1	Valve	Soupape	Válvula
12		10 (A) Ref. 10	1	O-Ring	Joint torique	Junta de tipo O
13		10 Ref. 10	1	Spring	Ressort	Muelle
14		10 Ref. 10	1	Spring	Ressort	Muelle
15		10 Ref. 10	1	Body	Corps	Cuerpo
16	6193787M91	2 225 Bar	1	Valve, Press. Relief	Soupape de sécurité	Válvula de seguridad
17	6193791M91	16 L/S Valve	1	Kit, Seal	Pochette de joints	Juego de juntas
18		17 Ref. 17	1	O-Ring	Joint torique	Junta de tipo O
19		17 Ref. 17	1	O-Ring	Joint torique	Junta de tipo O
20		17 Ref. 17	1	O-Ring	Joint torique	Junta de tipo O
21		16 Ref. 16	1	Valve	Soupape	Válvula
22		16 Ref. 16	1	Nut	Écrou	Tuerca
23		2 Ref. 2	X	Cover	Cache	Tapa
24	6193788M91	2	1	Valve, Anti-Excess Flow	Valve anti-surdébit	Válv. antisobrecaud.
25		24 Ref. 24	1	Valve	Soupape	Válvula
26		24 Ref. 24	1	Element	Élément	Elemento
27	6193790M91	24 Flow regulator	1	Kit, Seal	Pochette de joints	Juego de juntas
28		27 Ref. 27	1	O-Ring	Joint torique	Junta de tipo O
29		27 Ref. 27	1	O-Ring	Joint torique	Junta de tipo O
30		27 Ref. 27	1	O-Ring	Joint torique	Junta de tipo O
31	6193771M91	2 Interface	1	Kit, Seal	Pochette de joints	Juego de juntas
32		31 (A) Ref. 31	3	O-Ring	Joint torique	Junta de tipo O
33		31 (A) Ref. 31	1	O-Ring	Joint torique	Junta de tipo O
34	6193789M91	2 (B) Inlet element	1	Kit, Seal	Pochette de joints	Juego de juntas
35		35 Ref. 35	1	O-Ring	Joint torique	Junta de tipo O
36		35 Ref. 35	3	O-Ring	Joint torique	Junta de tipo O
37		35 Ref. 35	1	O-Ring	Joint torique	Junta de tipo O

38001C02.1

6199042M3

1

Jan-06

Hydraulic Valve
Distributeur de Commande Hydraulique
Distribuidor de mando hidráulico

Backhoe Control
Godet Rétro
Equipo retro

Inlet
 Admission
 Admisión

Sideshift digger
 Sideshift digger
 Sideshift digger

C-38001-02.1-A

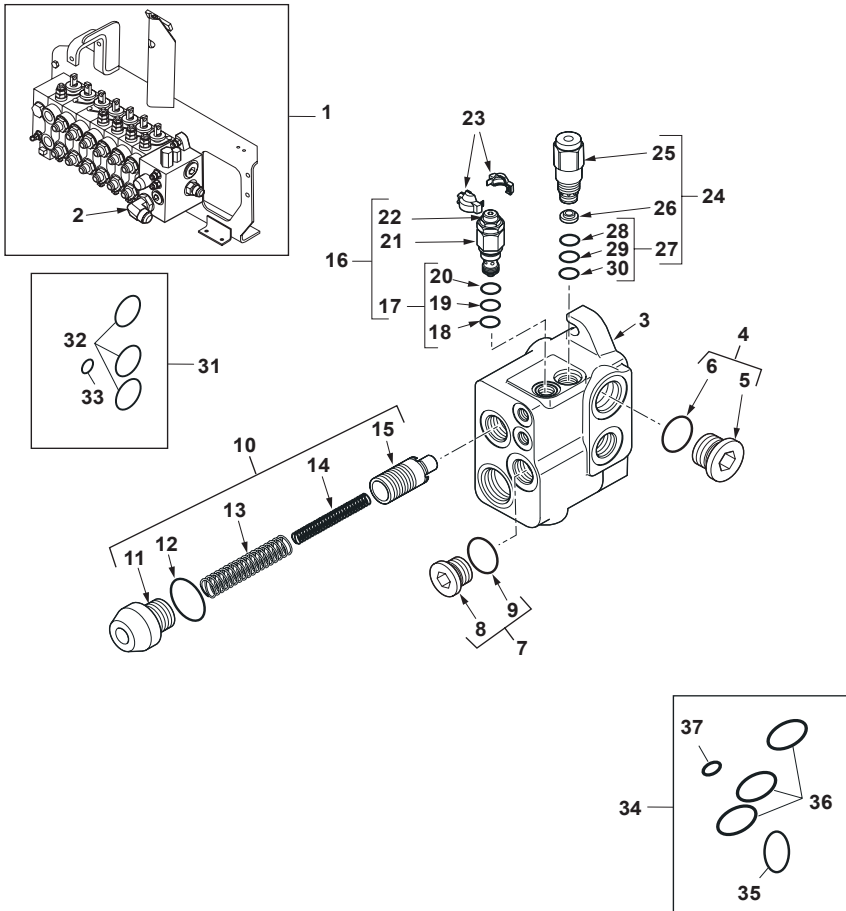

- A Included in kit marked (B)
 Inclus dans jeu marqué (B)
 Incluido en juego marcado (B)
- C Part number to be advised
 Référence pièce à demander
 Indicar número de pieza

- B Contains items marked (A)
 Comprend les pièces marquées (A)
 Incluye las piezas marcadas (A)



860
 TX860B

825

38001C02.1

6199042M3

1

Jan-06

Hydraulic Valve
Distributeur de Commande Hydraulique
Distribuidor de mando hidráulico

Backhoe Control
Godet Rétro
Equipo retro

Slew
 Pivot
 Pivote

Sideshift digger
 Sideshift digger
 Sideshift digger

C-38001-03.1-A

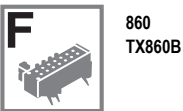
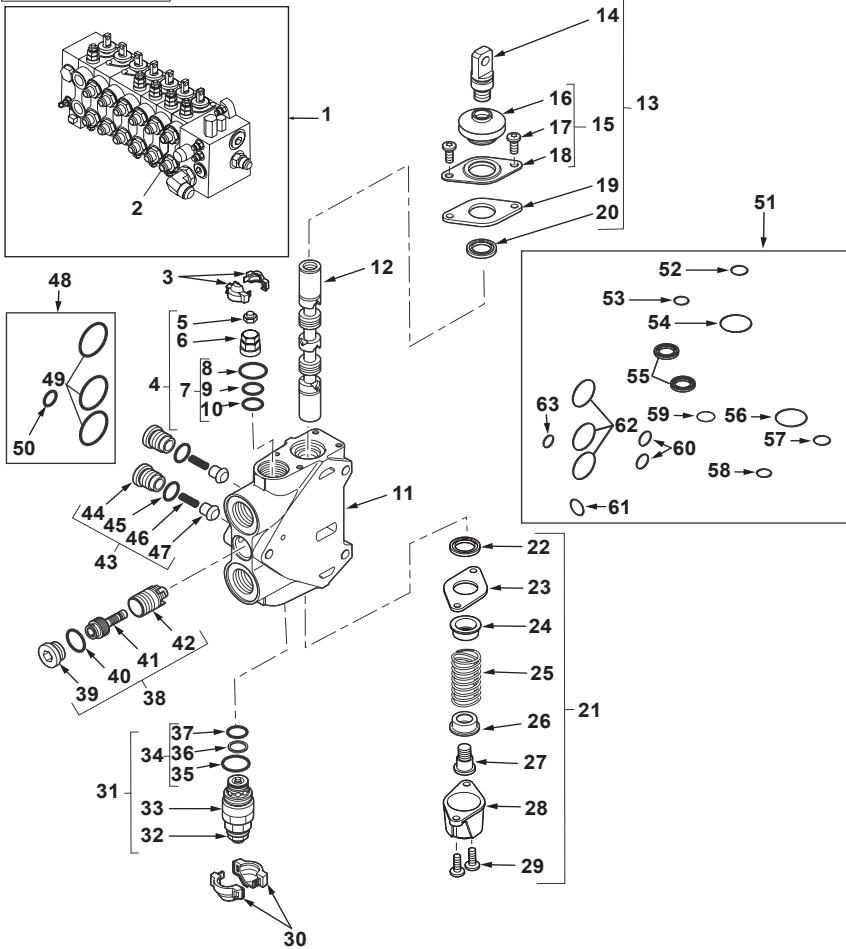

38001C03.1

6199042M3

1

Jan-06

1	6109206M91		Continued	1	Valve Assy, Control	Ensemble distribution	Distribuidor, Conj.
2		1	(C)	1	Valve Assy	Ensemble de soupape	Válvula, Conj.
3		2	Ref. 2	X	Cover	Cache	Tapa
4	6193778M91	2		1	Valve, Press. Relief	Soupape de sécurité	Válvula de seguridad
5		4	Ref. 4	1	Nut	Écrou	Tuerca
6		4	Ref. 4	1	Valve	Soupape	Válvula
7	6193779M91	4	Secondary Valves	1	Kit, Seal	Pochette de joints	Juego de juntas
8		7	Ref. 7	1	O-Ring	Joint torique	Junta de tipo O
9		7	Ref. 7	1	O-Ring	Joint torique	Junta de tipo O
10		7	Ref. 7	1	O-Ring	Joint torique	Junta de tipo O
11		2	Ref. 2	1	Body	Corps	Cuerpo
12		2	Ref. 2	1	Spool	Tiroir	Cajoncillo
13	6193780M91	2	Mech. Optd Z1	1	Kit, Parts	Lot de pièces	Juego de piezas
14		13	Ref. 13	1	Screw	Vis	Tornillo
15	6193783M91	13	Bellows	1	Kit, Parts	Lot de pièces	Juego de piezas
16		15	Ref. 15	1	Seal	Joint	Junta
17		15	Ref. 15	1	Screw	Vis	Tornillo
18		15	Ref. 15	2	Cover	Cache	Tapa
19		13	Ref. 13	1	Plate	Plaque	Placa
20	6194492M1	13	Lip	1	Seal	Joint	Junta
21	6193784M91	2	Mech Optd A2	1	Kit, Parts	Lot de pièces	Juego de piezas
22	6194492M1	21	Lip	1	Seal	Joint	Junta
23		21	Ref. 21	1	Plate	Plaque	Placa
24		21	Ref. 21	1	Holder	Porte-injecteur	Retén
25		21	Ref. 21	1	Spring	Ressort	Muelle
26		21	Ref. 21	1	Holder	Porte-injecteur	Retén
27		21	Ref. 21	1	Screw	Vis	Tornillo
28		21	Ref. 21	1	Cap	Chapeau	Sombbrero
29		21	Ref. 21	2	Screw	Vis	Tornillo
30		2	Ref. 21	X	Cover	Cache	Tapa
31	6193778M91	2		1	Valve, Press. Relief	Soupape de sécurité	Válvula de seguridad
32		31	Ref. 31	1	Nut	Écrou	Tuerca
33		31	Ref. 31	1	Valve	Soupape	Válvula
34	6193779M91	31	Secondary Valves	1	Kit, Seal	Pochette de joints	Juego de juntas
35		34	Ref. 34	1	O-Ring	Joint torique	Junta de tipo O
36		34	Ref. 34	1	O-Ring	Joint torique	Junta de tipo O
37		34	Ref. 34	1	O-Ring	Joint torique	Junta de tipo O
38	6193774M91	2	Compensator	1	Valve Assy	Ensemble de soupape	Válvula, Conj.
39		38	Ref. 38	1	Plug	Bouchon	Tapón
40		38	Ref. 38	1	O-Ring	Joint torique	Junta de tipo O
41		38	Ref. 38	1	Valve	Soupape	Válvula
42		38	Ref. 38	1	Body	Corps	Cuerpo
43	6193775M91	2		2	Valve, Check	Clapet anti-retour	Válvula de parada
44		43	Ref. 43	1	Plug	Bouchon	Tapón

Hydraulic Valve
Distributeur de Commande Hydraulique
Distribuidor de mando hidráulico

Backhoe Control
Godet Rétro
Equipo retro

Slew
 Pivot
 Pivote

Sideshift digger
 Sideshift digger
 Sideshift digger

C-38001-03.1-A

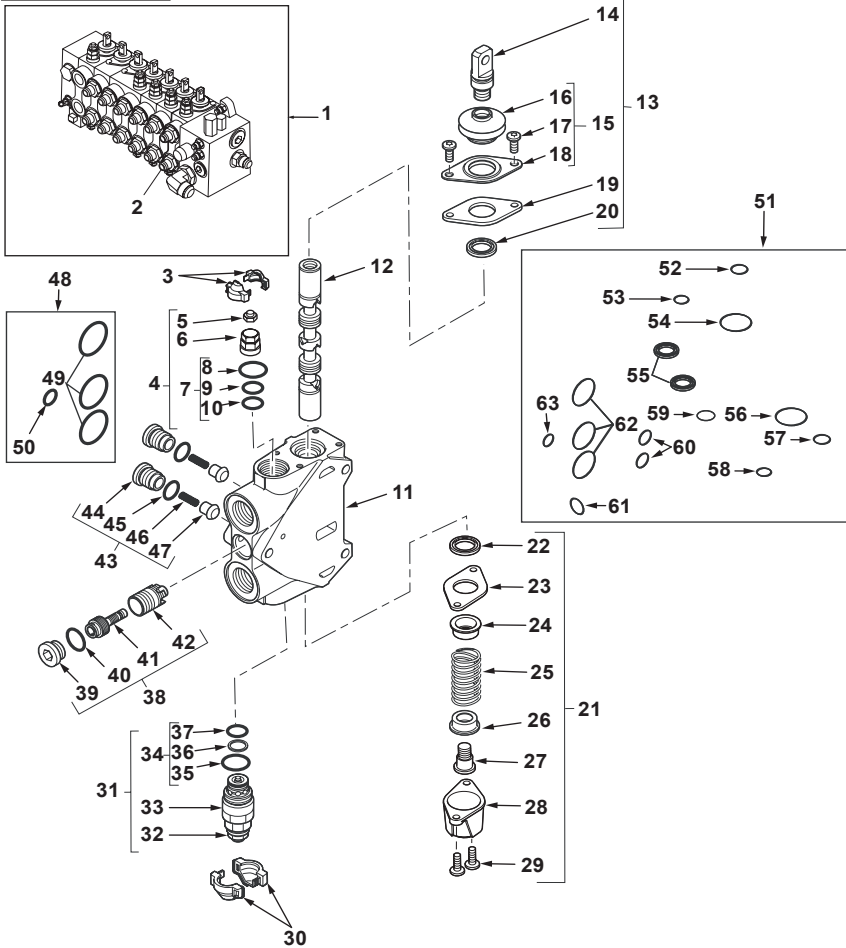

45		43	Ref. 43	1	O-Ring	Joint torique	Junta de tipo O
46		43	Ref. 43	1	Spring	Ressort	Muelle
47		43	Ref. 43	1	Valve	Soupape	Válvula
48	6193771M91	2	Interface	1	Kit, Seal	Pochette de joints	Juego de juntas
49		48	(A) Ref. 48	3	O-Ring	Joint torique	Junta de tipo O
50		48	(A) Ref. 48	1	O-Ring	Joint torique	Junta de tipo O
51	6193781M91	(B)		X	Kit, Seal	Pochette de joints	Juego de juntas
52		51	18.77 x 1.78 Ref. 51	1	O-Ring	Joint torique	Junta de tipo O
53		51	15.6 x 1.78 Ref. 51	1	O-Ring	Joint torique	Junta de tipo O
54		51	36.3 x 1.78 Ref. 51	1	O-Ring	Joint torique	Junta de tipo O
55	6194492M1	51	Lip	2	Seal	Joint	Junta
56		51	36.3 x 1.78 Ref. 51	1	O-Ring	Joint torique	Junta de tipo O
57		51	18.77 x 1.78 Ref. 51	1	O-Ring	Joint torique	Junta de tipo O
58		51	15.6 x 1.78 Ref. 51	1	O-Ring	Joint torique	Junta de tipo O
59		51	18 x 2.5 Ref. 51	1	O-Ring	Joint torique	Junta de tipo O
60		51	15 x 2 Ref. 51	2	O-Ring	Joint torique	Junta de tipo O
61		51	19.4 x 2.1 Ref. 51	1	O-Ring	Joint torique	Junta de tipo O
62		51	29.82 x 2.62 Ref. 51	3	O-Ring	Joint torique	Junta de tipo O
63		51	10.77 x 2.62 Ref. 51	1	O-Ring	Joint torique	Junta de tipo O

A Included in kit marked (B)
 Inclus dans jeu marqué (B)
 Incluido en juego marcado (B)
 Part number to be advised
 Référence pièce à demander
 Indicar número de pieza

B Contains items marked (A)
 Comprend les pièces marquées (A)
 Incluye las piezas marcadas (A)



860
 TX860B

825

38001C03.1

6199042M3

1

Jan-06

Hydraulic Valve
Distributeur de Commande Hydraulique
Distribuidor de mando hidráulico

Backhoe Control
Godet Rétro
Equipo retro

Boom
Flèche
Pluma

Sideshift digger
Sideshift digger
Sideshift digger

C-38001-04.1-A

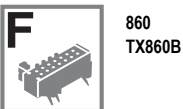
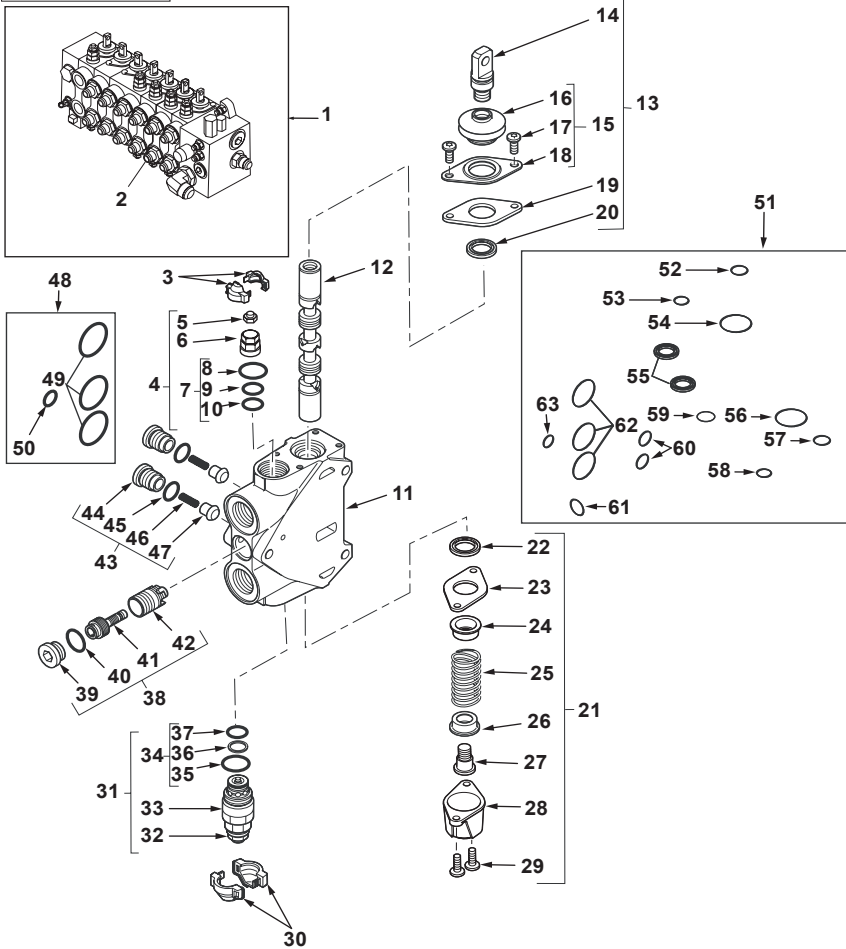

860
TX860B

825

38001C04.1

6199042M3

1

Jan-06

1	6109206M91		Continued	1	Valve Assy, Control	Ensemble distribution	Distribuidor, Conj.
2		1	(C)	1	Valve Assy	Ensemble de soupape	Válvula, Conj.
3		2	Ref. 2	X	Cover	Cache	Tapa
4	6193778M91	2		1	Valve, Press. Relief	Soupape de sécurité	Válvula de seguridad
5		4	Ref. 4	1	Nut	Écrou	Tuerca
6		4	Ref. 4	1	Valve	Soupape	Válvula
7	6193779M91	4	Secondary Valves	1	Kit, Seal	Pochette de joints	Juego de juntas
8		7	Ref. 7	1	O-Ring	Joint torique	Junta de tipo O
9		7	Ref. 7	1	O-Ring	Joint torique	Junta de tipo O
10		7	Ref. 7	1	O-Ring	Joint torique	Junta de tipo O
11		2	Ref. 2	1	Body	Corps	Cuerpo
12		2	Ref. 2	1	Spool	Tiroir	Cajoncillo
13	6193780M91	2	Mech. Optd Z1	1	Kit, Parts	Lot de pièces	Juego de piezas
14		13	Ref. 13	1	Screw	Vis	Tornillo
15	6193783M91	13	Bellows	1	Kit, Parts	Lot de pièces	Juego de piezas
16		15	Ref. 15	1	Seal	Joint	Junta
17		15	Ref. 15	1	Screw	Vis	Tornillo
18		15	Ref. 15	2	Cover	Cache	Tapa
19		13	Ref. 13	1	Plate	Plaque	Placa
20	6194492M1	13	Lip	1	Seal	Joint	Junta
21	6193784M91	2	Mech Optd A2	1	Kit, Parts	Lot de pièces	Juego de piezas
22	6194492M1	21	Lip	1	Seal	Joint	Junta
23		21	Ref. 21	1	Plate	Plaque	Placa
24		21	Ref. 21	1	Holder	Porte-injecteur	Retén
25		21	Ref. 21	1	Spring	Ressort	Muelle
26		21	Ref. 21	1	Holder	Porte-injecteur	Retén
27		21	Ref. 21	1	Screw	Vis	Tornillo
28		21	Ref. 21	1	Cap	Chapeau	Sombbrero
29		21	Ref. 21	2	Screw	Vis	Tornillo
30		2	Ref. 21	X	Cover	Cache	Tapa
31	6193778M91	2		1	Valve, Press. Relief	Soupape de sécurité	Válvula de seguridad
32		31	Ref. 31	1	Nut	Écrou	Tuerca
33		31	Ref. 31	1	Valve	Soupape	Válvula
34	6193779M91	31	Secondary Valves	1	Kit, Seal	Pochette de joints	Juego de juntas
35		34	Ref. 34	1	O-Ring	Joint torique	Junta de tipo O
36		34	Ref. 34	1	O-Ring	Joint torique	Junta de tipo O
37		34	Ref. 34	1	O-Ring	Joint torique	Junta de tipo O
38	6193774M91	2	Compensator	1	Valve Assy	Ensemble de soupape	Válvula, Conj.
39		38	Ref. 38	1	Plug	Bouchon	Tapón
40		38	Ref. 38	1	O-Ring	Joint torique	Junta de tipo O
41		38	Ref. 38	1	Valve	Soupape	Válvula
42		38	Ref. 38	1	Body	Corps	Cuerpo
43	6193775M91	2		2	Valve, Check	Clapet anti-retour	Válvula de parada
44		43	Ref. 43	1	Plug	Bouchon	Tapón

Hydraulic Valve
Distributeur de Commande Hydraulique
Distribuidor de mando hidráulico

Backhoe Control
Godet Rétro
Equipo retro

Boom
 Flèche
 Pluma

Sideshift digger
 Sideshift digger
 Sideshift digger

C-38001-04.1-A

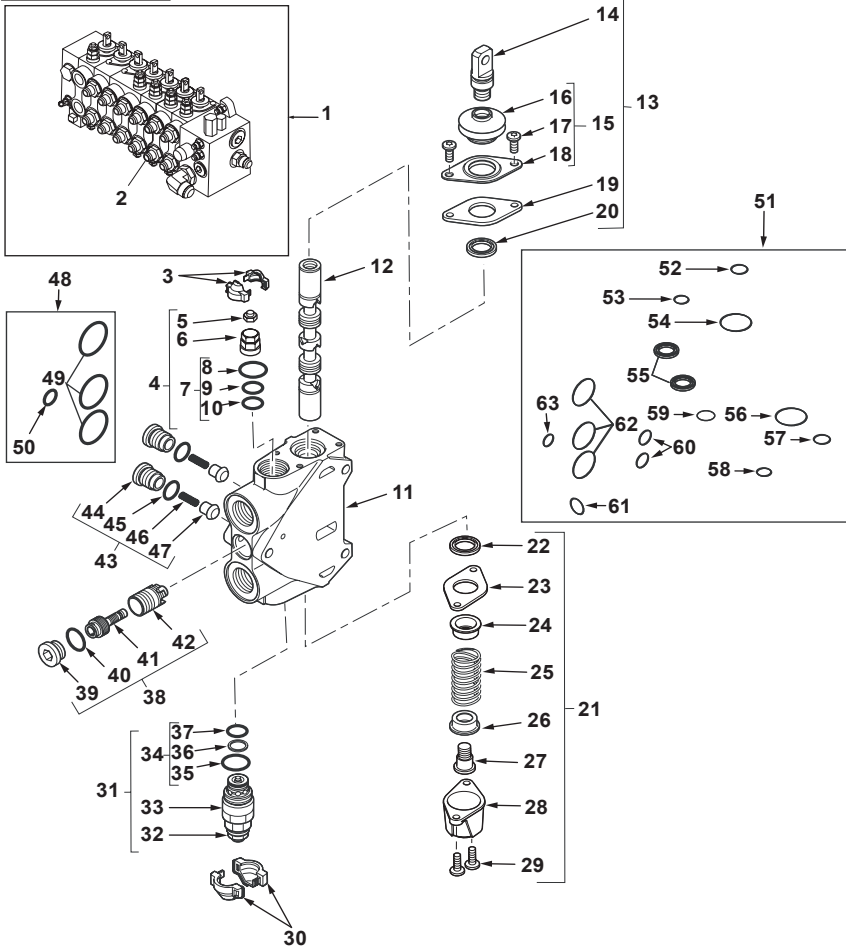

45		43	Ref. 43	1	O-Ring	Joint torique	Junta de tipo O
46		43	Ref. 43	1	Spring	Ressort	Muelle
47		43	Ref. 43	1	Valve	Soupape	Válvula
48	6193771M91	2	Interface	1	Kit, Seal	Pochette de joints	Juego de juntas
49		48	(A) Ref. 48	3	O-Ring	Joint torique	Junta de tipo O
50		48	(A) Ref. 48	1	O-Ring	Joint torique	Junta de tipo O
51	6193781M91	(B)	X Kit, Seal		Kit, Seal	Pochette de joints	Juego de juntas
52		51	18.77 x 1.78 Ref. 51	1	O-Ring	Joint torique	Junta de tipo O
53		51	15.6 x 1.78 Ref. 51	1	O-Ring	Joint torique	Junta de tipo O
54		51	36.3 x 1.78 Ref. 51	1	O-Ring	Joint torique	Junta de tipo O
55	6194492M1	51	Lip	2	Seal	Joint	Junta
56		51	36.3 x 1.78 Ref. 51	1	O-Ring	Joint torique	Junta de tipo O
57		51	18.77 x 1.78 Ref. 51	1	O-Ring	Joint torique	Junta de tipo O
58		51	15.6 x 1.78 Ref. 51	1	O-Ring	Joint torique	Junta de tipo O
59		51	18 x 2.5 Ref. 51	1	O-Ring	Joint torique	Junta de tipo O
60		51	15 x 2 Ref. 51	2	O-Ring	Joint torique	Junta de tipo O
61		51	19.4 x 2.1 Ref. 51	1	O-Ring	Joint torique	Junta de tipo O
62		51	29.82 x 2.62 Ref. 51	3	O-Ring	Joint torique	Junta de tipo O
63		51	10.77 x 2.62 Ref. 51	1	O-Ring	Joint torique	Junta de tipo O

A Included in kit marked (B)
 Inclus dans jeu marqué (B)
 Incluido en juego marcado (B)
 Part number to be advised
 Référence pièce à demander
 Indicar número de pieza

B Contains items marked (A)
 Comprend les pièces marquées (A)
 Incluye las piezas marcadas (A)



860
 TX860B

825

38001C04.1

6199042M3

1

Jan-06

Hydraulic Valve
Distributeur de Commande Hydraulique
Distribuidor de mando hidráulico

Backhoe Control
Godet Rétro
Equipo retro

Dipper
Balancier
Balancín

Sideshift digger
Sideshift digger
Sideshift digger

C-38001-05.1-A

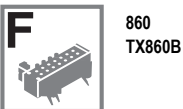
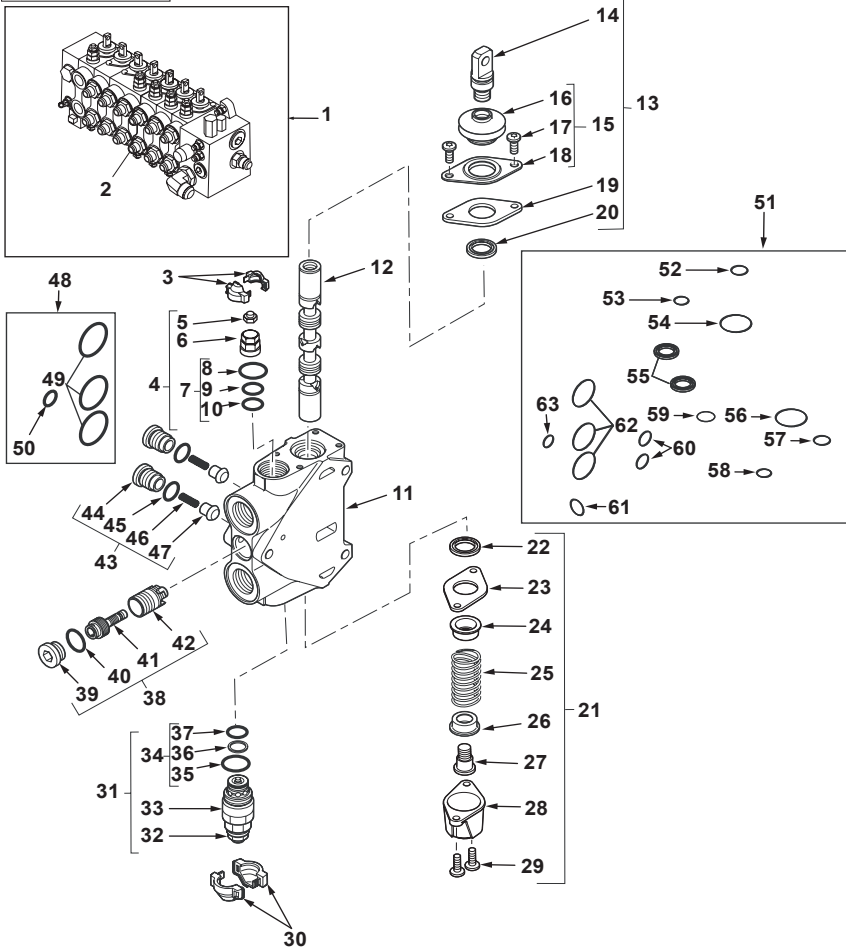

825

38001C05.1

6199042M3

1

Jan-06

1	6109206M91		Continued	1	Valve Assy, Control	Ensemble distribution	Distribuidor, Conj.
2		1	(C)	1	Valve Assy	Ensemble de soupape	Válvula, Conj.
3		2	Ref. 2	X	Cover	Cache	Tapa
4	6193778M91	2		1	Valve, Press. Relief	Soupape de sécurité	Válvula de seguridad
5		4	Ref. 4	1	Nut	Écrou	Tuerca
6		4	Ref. 4	1	Valve	Soupape	Válvula
7	6193779M91	4	Secondary Valves	1	Kit, Seal	Pochette de joints	Juego de juntas
8		7	Ref. 7	1	O-Ring	Joint torique	Junta de tipo O
9		7	Ref. 7	1	O-Ring	Joint torique	Junta de tipo O
10		7	Ref. 7	1	O-Ring	Joint torique	Junta de tipo O
11		2	Ref. 2	1	Body	Corps	Cuerpo
12		2	Ref. 2	1	Spool	Tiroir	Cajoncillo
13	6193780M91	2	Mech. Optd Z1	1	Kit, Parts	Lot de pièces	Juego de piezas
14		13	Ref. 13	1	Screw	Vis	Tornillo
15	6193783M91	13	Bellows	1	Kit, Parts	Lot de pièces	Juego de piezas
16		15	Ref. 15	1	Seal	Joint	Junta
17		15	Ref. 15	1	Screw	Vis	Tornillo
18		15	Ref. 15	2	Cover	Cache	Tapa
19		13	Ref. 13	1	Plate	Plaque	Placa
20	6194492M1	13	Lip	1	Seal	Joint	Junta
21	6193784M91	2	Mech Optd A2	1	Kit, Parts	Lot de pièces	Juego de piezas
22	6194492M1	21	Lip	1	Seal	Joint	Junta
23		21	Ref. 21	1	Plate	Plaque	Placa
24		21	Ref. 21	1	Holder	Porte-injecteur	Retén
25		21	Ref. 21	1	Spring	Ressort	Muelle
26		21	Ref. 21	1	Holder	Porte-injecteur	Retén
27		21	Ref. 21	1	Screw	Vis	Tornillo
28		21	Ref. 21	1	Cap	Chapeau	Sombbrero
29		21	Ref. 21	2	Screw	Vis	Tornillo
30		2	Ref. 21	X	Cover	Cache	Tapa
31	6193778M91	2		1	Valve, Press. Relief	Soupape de sécurité	Válvula de seguridad
32		31	Ref. 31	1	Nut	Écrou	Tuerca
33		31	Ref. 31	1	Valve	Soupape	Válvula
34	6193779M91	31	Secondary Valves	1	Kit, Seal	Pochette de joints	Juego de juntas
35		34	Ref. 34	1	O-Ring	Joint torique	Junta de tipo O
36		34	Ref. 34	1	O-Ring	Joint torique	Junta de tipo O
37		34	Ref. 34	1	O-Ring	Joint torique	Junta de tipo O
38	6193792M91	2	Compensator	1	Valve Assy	Ensemble de soupape	Válvula, Conj.
39		38	Ref. 38	1	Plug	Bouchon	Tapón
40		38	Ref. 38	1	O-Ring	Joint torique	Junta de tipo O
41		38	Ref. 38	1	Valve	Soupape	Válvula
42		38	Ref. 38	1	Body	Corps	Cuerpo
43	6193775M91	2		2	Valve, Check	Clapet anti-retour	Válvula de parada
44		43	Ref. 43	1	Plug	Bouchon	Tapón

Hydraulic Valve
Distributeur de Commande Hydraulique
Distribuidor de mando hidráulico

Backhoe Control
Godet Rétro
Equipo retro

Dipper
Balancier
Balancín

Sideshift digger
Sideshift digger
Sideshift digger

C-38001-05.1-A

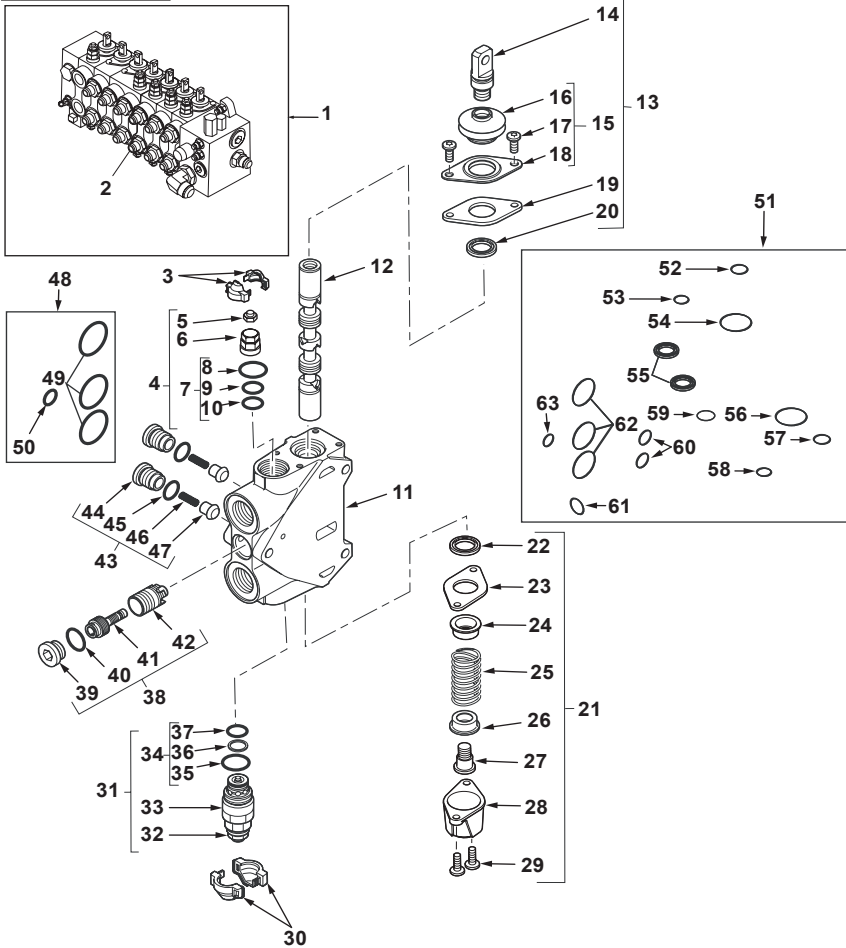

45		43	Ref. 43	1	O-Ring	Joint torique	Junta de tipo O
46		43	Ref. 43	1	Spring	Ressort	Muelle
47		43	Ref. 43	1	Valve	Soupape	Válvula
48	6193771M91	2	Interface	1	Kit, Seal	Pochette de joints	Juego de juntas
49		48	(A) Ref. 48	3	O-Ring	Joint torique	Junta de tipo O
50		48	(A) Ref. 48	1	O-Ring	Joint torique	Junta de tipo O
51	6193781M91	(B)	X Kit, Seal		Kit, Seal	Pochette de joints	Juego de juntas
52		51	18.77 x 1.78 Ref. 51	1	O-Ring	Joint torique	Junta de tipo O
53		51	15.6 x 1.78 Ref. 51	1	O-Ring	Joint torique	Junta de tipo O
54		51	36.3 x 1.78 Ref. 51	1	O-Ring	Joint torique	Junta de tipo O
55	6194492M1	51	Lip	2	Seal	Joint	Junta
56		51	36.3 x 1.78 Ref. 51	1	O-Ring	Joint torique	Junta de tipo O
57		51	18.77 x 1.78 Ref. 51	1	O-Ring	Joint torique	Junta de tipo O
58		51	15.6 x 1.78 Ref. 51	1	O-Ring	Joint torique	Junta de tipo O
59		51	18 x 2.5 Ref. 51	1	O-Ring	Joint torique	Junta de tipo O
60		51	15 x 2 Ref. 51	2	O-Ring	Joint torique	Junta de tipo O
61		51	19.4 x 2.1 Ref. 51	1	O-Ring	Joint torique	Junta de tipo O
62		51	29.82 x 2.62 Ref. 51	3	O-Ring	Joint torique	Junta de tipo O
63		51	10.77 x 2.62 Ref. 51	1	O-Ring	Joint torique	Junta de tipo O

A Included in kit marked (B)
 Inclus dans jeu marqué (B)
 Incluido en juego marcado (B)
 Part number to be advised
 Référence pièce à demander
 Indicar número de pieza

B Contains items marked (A)
 Comprend les pièces marquées (A)
 Incluye las piezas marcadas (A)



860
TX860B

825

38001C05.1

6199042M3

1

Jan-06

Hydraulic Valve
Distributeur de Commande Hydraulique
Distribuidor de mando hidráulico

Backhoe Control
Godet Rétro
Equipo retro

Bucket
Godet
Cuchara

Sideshift digger
Sideshift digger
Sideshift digger

C-38001-06.1-A

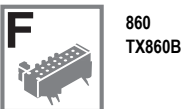
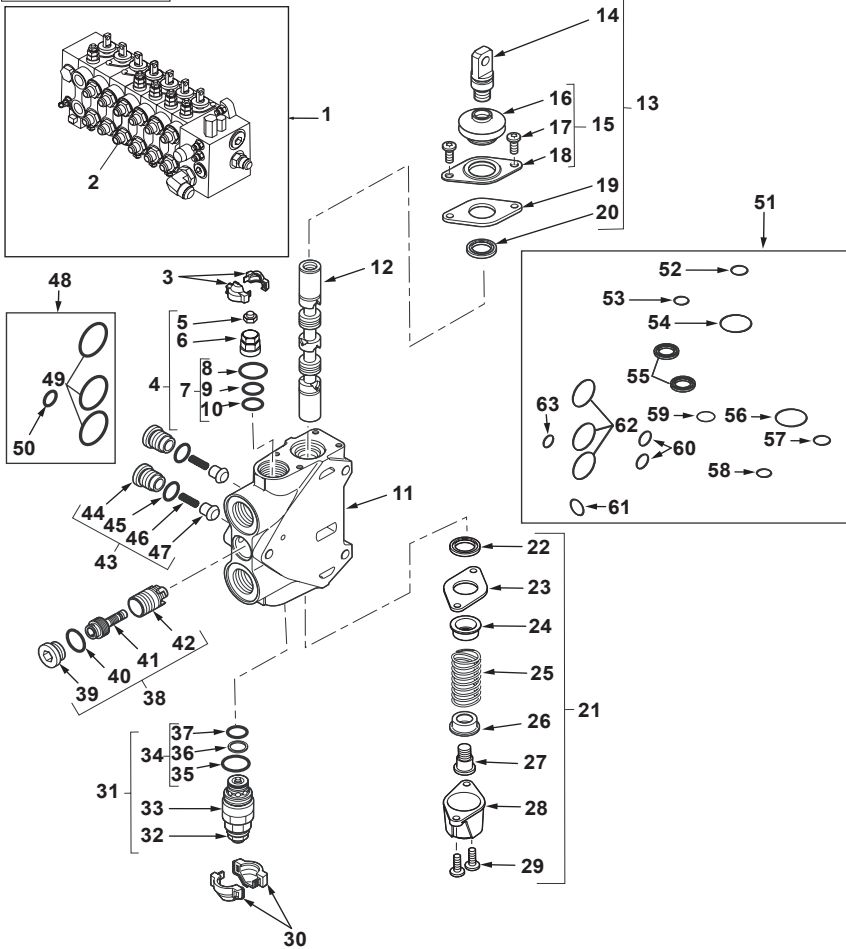

860
TX860B

825

38001C06.1

6199042M3

1

Jan-06

1	6109206M91		Continued	1	Valve Assy, Control	Ensemble distribution	Distribuidor, Conj.
2		1	(C)	1	Valve Assy	Ensemble de soupape	Válvula, Conj.
3		2	Ref. 2	X	Cover	Cache	Tapa
4	6193778M91	2		1	Valve, Press. Relief	Soupape de sécurité	Válvula de seguridad
5		4	Ref. 4	1	Nut	Écrou	Tuerca
6		4	Ref. 4	1	Valve	Soupape	Válvula
7	6193779M91	4	Secondary Valves	1	Kit, Seal	Pochette de joints	Juego de juntas
8		7	Ref. 7	1	O-Ring	Joint torique	Junta de tipo O
9		7	Ref. 7	1	O-Ring	Joint torique	Junta de tipo O
10		7	Ref. 7	1	O-Ring	Joint torique	Junta de tipo O
11		2	Ref. 2	1	Body	Corps	Cuerpo
12		2	Ref. 2	1	Spool	Tiroir	Cajoncillo
13	6193780M91	2	Mech. Optd Z1	1	Kit, Parts	Lot de pièces	Juego de piezas
14		13	Ref. 13	1	Screw	Vis	Tornillo
15	6193783M91	13	Bellows	1	Kit, Parts	Lot de pièces	Juego de piezas
16		15	Ref. 15	1	Seal	Joint	Junta
17		15	Ref. 15	1	Screw	Vis	Tornillo
18		15	Ref. 15	2	Cover	Cache	Tapa
19		13	Ref. 13	1	Plate	Plaque	Placa
20	6194492M1	13	Lip	1	Seal	Joint	Junta
21	6193784M91	2	Mech Optd A2	1	Kit, Parts	Lot de pièces	Juego de piezas
22	6194492M1	21	Lip	1	Seal	Joint	Junta
23		21	Ref. 21	1	Plate	Plaque	Placa
24		21	Ref. 21	1	Holder	Porte-injecteur	Retén
25		21	Ref. 21	1	Spring	Ressort	Muelle
26		21	Ref. 21	1	Holder	Porte-injecteur	Retén
27		21	Ref. 21	1	Screw	Vis	Tornillo
28		21	Ref. 21	1	Cap	Chapeau	Sombbrero
29		21	Ref. 21	2	Screw	Vis	Tornillo
30		2	Ref. 21	X	Cover	Cache	Tapa
31	6193778M91	2		1	Valve, Press. Relief	Soupape de sécurité	Válvula de seguridad
32		31	Ref. 31	1	Nut	Écrou	Tuerca
33		31	Ref. 31	1	Valve	Soupape	Válvula
34	6193779M91	31	Secondary Valves	1	Kit, Seal	Pochette de joints	Juego de juntas
35		34	Ref. 34	1	O-Ring	Joint torique	Junta de tipo O
36		34	Ref. 34	1	O-Ring	Joint torique	Junta de tipo O
37		34	Ref. 34	1	O-Ring	Joint torique	Junta de tipo O
38	6193774M91	2	Compensator	1	Valve Assy	Ensemble de soupape	Válvula, Conj.
39		38	Ref. 38	1	Plug	Bouchon	Tapón
40		38	Ref. 38	1	O-Ring	Joint torique	Junta de tipo O
41		38	Ref. 38	1	Valve	Soupape	Válvula
42		38	Ref. 38	1	Body	Corps	Cuerpo
43	6193775M91	2		2	Valve, Check	Clapet anti-retour	Válvula de parada
44		43	Ref. 43	1	Plug	Bouchon	Tapón

Hydraulic Valve
Distributeur de Commande Hydraulique
Distribuidor de mando hidráulico

Backhoe Control
Godet Rétro
Equipo retro

Bucket
Godet
Cuchara

Sideshift digger
Sideshift digger
Sideshift digger

C-38001-06.1-A

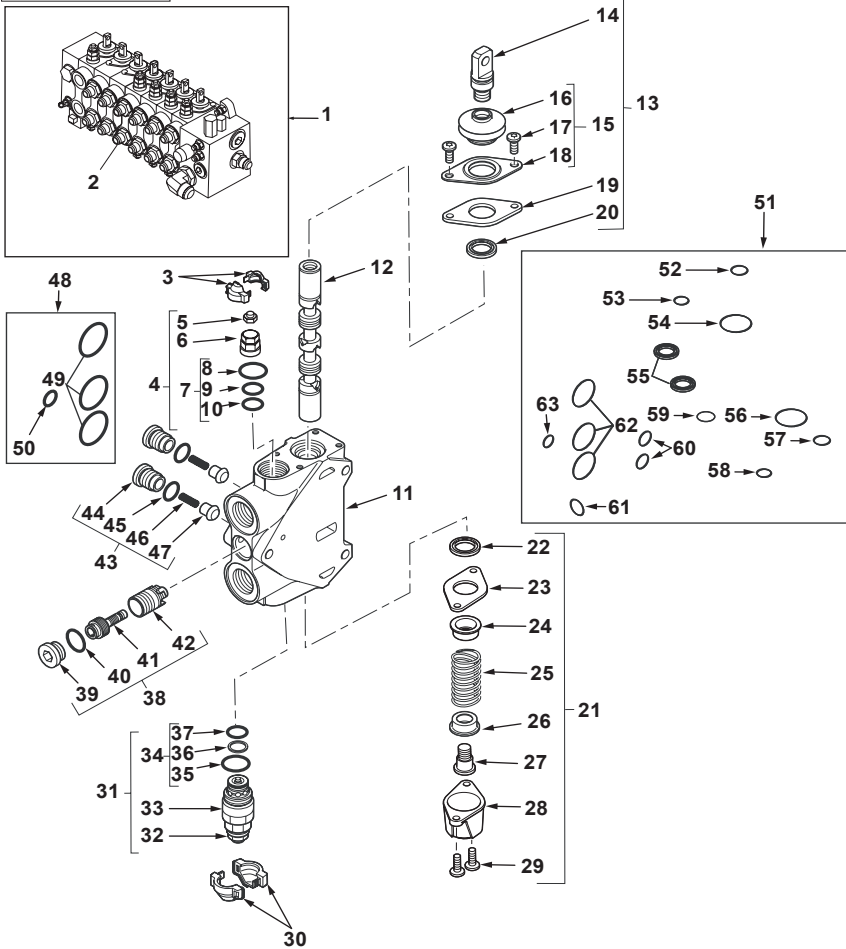

45		43		Ref. 43	1	O-Ring	Joint torique	Junta de tipo O
46		43		Ref. 43	1	Spring	Ressort	Muelle
47		43		Ref. 43	1	Valve	Soupape	Válvula
48	6193771M91	2		Interface	1	Kit, Seal	Pochette de joints	Juego de juntas
49		48		Ref. 48	3	O-Ring	Joint torique	Junta de tipo O
50		48		Ref. 48	1	O-Ring	Joint torique	Junta de tipo O
51	6193781M91	(B)			X	Kit, Seal	Pochette de joints	Juego de juntas
52		51		18.77 x 1.78 Ref. 51	1	O-Ring	Joint torique	Junta de tipo O
53		51		15.6 x 1.78 Ref. 51	1	O-Ring	Joint torique	Junta de tipo O
54		51		36.3 x 1.78 Ref. 51	1	O-Ring	Joint torique	Junta de tipo O
55	6194492M1	51		Lip	2	Seal	Joint	Junta
56		51		36.3 x 1.78 Ref. 51	1	O-Ring	Joint torique	Junta de tipo O
57		51		18.77 x 1.78 Ref. 51	1	O-Ring	Joint torique	Junta de tipo O
58		51		15.6 x 1.78 Ref. 51	1	O-Ring	Joint torique	Junta de tipo O
59		51		18 x 2.5 Ref. 51	1	O-Ring	Joint torique	Junta de tipo O
60		51		15 x 2 Ref. 51	2	O-Ring	Joint torique	Junta de tipo O
61		51		19.4 x 2.1 Ref. 51	1	O-Ring	Joint torique	Junta de tipo O
62		51		29.82 x 2.62 Ref. 51	3	O-Ring	Joint torique	Junta de tipo O
63		51		10.77 x 2.62 Ref. 51	1	O-Ring	Joint torique	Junta de tipo O

A Included in kit marked (B)
 Inclus dans jeu marqué (B)
 Incluido en juego marcado (B)
 Part number to be advised
 Référence pièce à demander
 Indicar número de pieza

B Contains items marked (A)
 Comprend les pièces marquées (A)
 Incluye las piezas marcadas (A)



860
TX860B

825

38001C06.1

6199042M3

1

Jan-06

Hydraulic Valve
Distributeur de Commande Hydraulique
Distribuidor de mando hidráulico

Backhoe Control
Godet Rétro
Equipo retro

Stabilizer
Stabilisateur
Estabilizador

Sideshift digger
Sideshift digger
Sideshift digger

C-38001-07.1-A

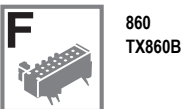
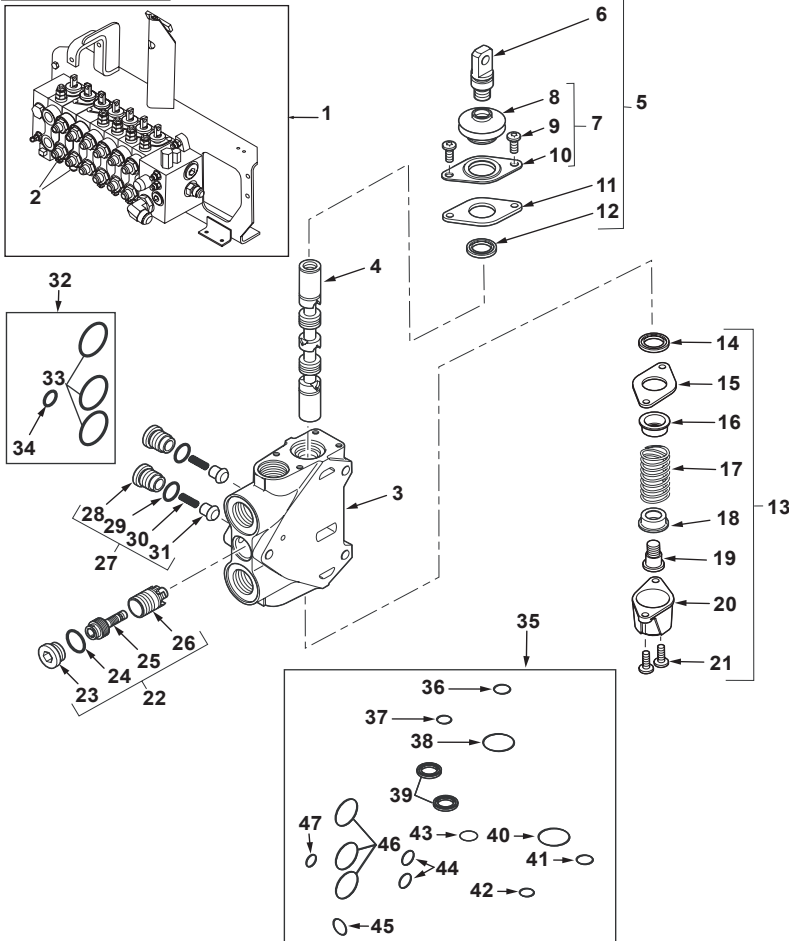

825

38001C07.1

6199042M3

1

Jan-06

1	6109206M91		Continued	1	Valve Assy, Control	Ensemble distribution	Distribuidor, Conj.
2		1	(C)	2	Valve Assy	Ensemble de soupape	Válvula, Conj.
3		2	Ref. 2	1	Body	Corps	Cuerpo
4		2	Ref. 2	1	Spool	Tiroir	Cajoncillo
5	6193780M91	2	Mech. Optd Z1	1	Kit, Parts	Lot de pièces	Juego de piezas
6		5	Ref. 5	1	Screw	Vis	Tornillo
7	6193783M91	5	Bellows	1	Kit, Parts	Lot de pièces	Juego de piezas
8		7	Ref. 7	1	Seal	Joint	Junta
9		7	Ref. 7	1	Screw	Vis	Tornillo
10		7	Ref. 7	2	Cover	Cache	Tapa
11		5	Ref. 5	1	Plate	Plaque	Placa
12	6194492M1	5	Lip	1	Seal	Joint	Junta
13	6193784M91	2	Mech Optd A2	1	Kit, Parts	Lot de pièces	Juego de piezas
14	6194492M1	13	Lip	1	Seal	Joint	Junta
15		13	Ref. 13	1	Plate	Plaque	Placa
16		13	Ref. 13	1	Holder	Porte-injecteur	Retén
17		13	Ref. 13	1	Spring	Ressort	Muelle
18		13	Ref. 13	1	Holder	Porte-injecteur	Retén
19		13	Ref. 13	1	Screw	Vis	Tornillo
20		13	Ref. 13	1	Cap	Chapeau	Sombbrero
21		13	Ref. 13	2	Screw	Vis	Tornillo
22	6193774M91	2	Compensator	1	Valve Assy	Ensemble de soupape	Válvula, Conj.
23		22	Ref. 22	1	Plug	Bouchon	Tapón
24		22	Ref. 22	1	O-Ring	Joint torique	Junta de tipo O
25		22	Ref. 22	1	Valve	Soupape	Válvula
26		22	Ref. 22	1	Body	Corps	Cuerpo
27	6193775M91	2		2	Valve, Check	Clapet anti-retour	Válvula de parada
28		27	Ref. 27	1	Plug	Bouchon	Tapón
29		27	Ref. 27	1	O-Ring	Joint torique	Junta de tipo O
30		27	Ref. 27	1	Spring	Ressort	Muelle
31		27	Ref. 27	1	Valve	Soupape	Válvula
32	6193771M91	2	Interface	1	Kit, Seal	Pochette de joints	Juego de juntas
33		32	(A) Ref. 32	3	O-Ring	Joint torique	Junta de tipo O
34		32	(A) Ref. 32	1	O-Ring	Joint torique	Junta de tipo O
35	6193781M91		(B)	X	Kit, Seal	Pochette de joints	Juego de juntas
36		35	18.77 x 1.78 Ref. 35	1	O-Ring	Joint torique	Junta de tipo O
37		35	15.6 x 1.78 Ref. 35	1	O-Ring	Joint torique	Junta de tipo O
38		35	36.3 x 1.78 Ref. 35	1	O-Ring	Joint torique	Junta de tipo O
39	6194492M1	35	Lip	2	Seal	Joint	Junta

Hydraulic Valve
Distributeur de Commande Hydraulique
Distribuidor de mando hidráulico

Backhoe Control
Godet Rétro
Equipo retro

Stabilizer
Stabilisateur
Estabilizador

Sideshift digger
Sideshift digger
Sideshift digger

C-38001-07.1-A

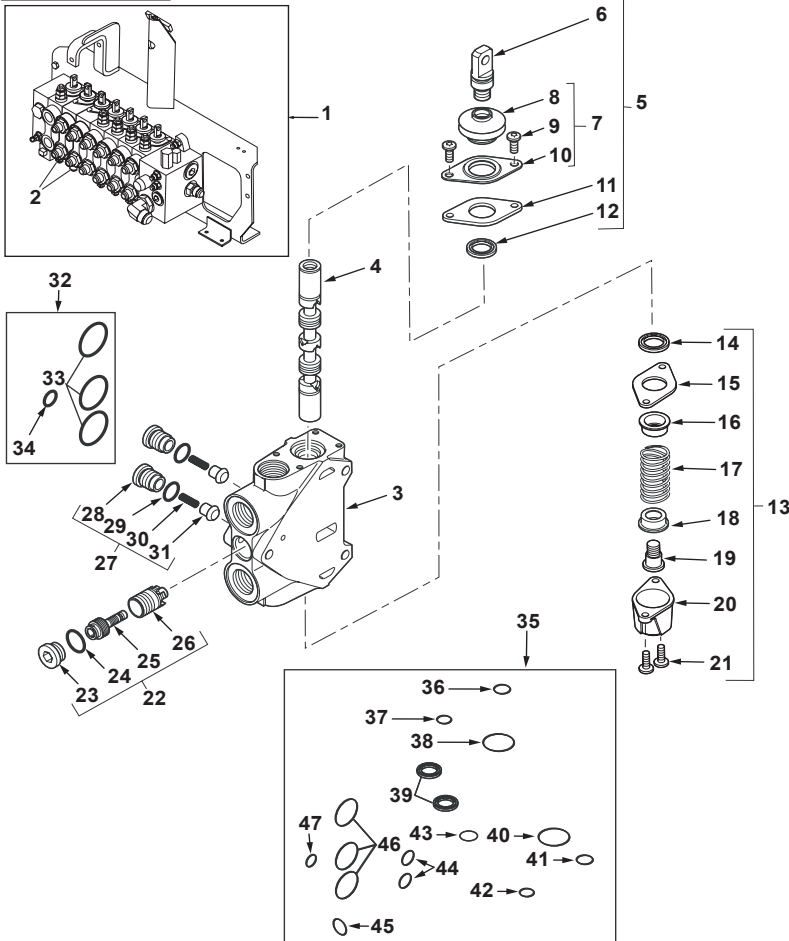

40	35	36.3 x 1.78 Ref. 35	1	O-Ring	Joint torique	Junta de tipo O
41	35	18.77 x 1.78 Ref. 35	1	O-Ring	Joint torique	Junta de tipo O
42	35	15.6 x 1.78 Ref. 35	1	O-Ring	Joint torique	Junta de tipo O
43	35	18 x 2.5 Ref. 35	1	O-Ring	Joint torique	Junta de tipo O
44	35	15 x 2 Ref. 35	2	O-Ring	Joint torique	Junta de tipo O
45	35	19.4 x 2.1 Ref. 35	1	O-Ring	Joint torique	Junta de tipo O
46	35	29.82 x 2.62 Ref. 35	3	O-Ring	Joint torique	Junta de tipo O
47	35	10.77 x 2.62 Ref. 35	1	O-Ring	Joint torique	Junta de tipo O

A Included in kit marked (B)
 Inclus dans jeu marqué (B)
 Incluido en juego marcado (B)
 C Part number to be advised
 Référence pièce à demander
 Indicar número de pieza

B Contains items marked (A)
 Comprend les pièces marquées (A)
 Incluye las piezas marcadas (A)



860
TX860B

825

38001C07.1

6199042M3

1

Jan-06

Hydraulic Valve
Distributeur de Commande Hydraulique
Distribuidor de mando hidráulico

Backhoe Control
Godet Rétro
Equipo retro

Auxiliary
 Auxiliaire
 Auxiliar

Sideshift digger
 Sideshift digger
 Sideshift digger

C-38001-08.1-A

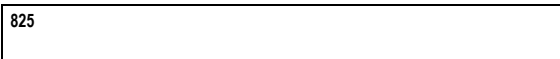
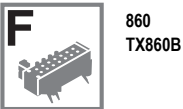
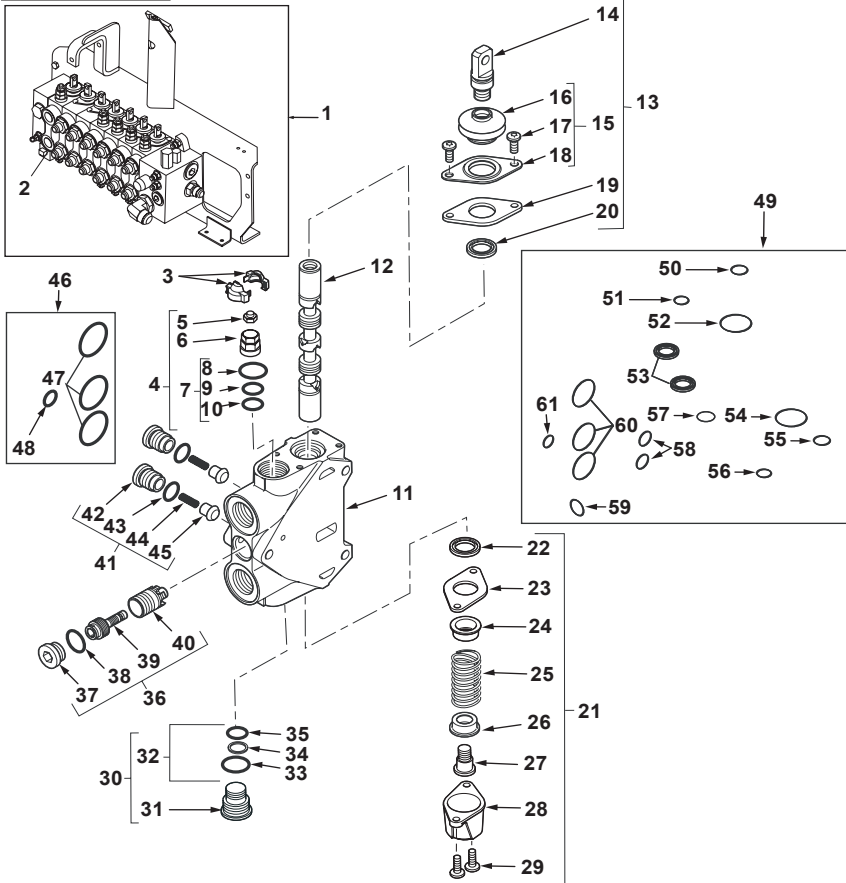

38001C08.1

6199042M3

1

Jan-06

1	6109206M91		Continued	1	Valve Assy, Control	Ensemble distribution	Distribuidor, Conj.
2		1	(C)	1	Valve Assy	Ensemble de soupape	Válvula, Conj.
3		2	Ref. 2	X	Cover	Cache	Tapa
4	6193778M91	2		1	Valve, Press. Relief	Soupape de sécurité	Válvula de seguridad
5		4	Ref. 4	1	Nut	Écrou	Tuerca
6		4	Ref. 4	1	Valve	Soupape	Válvula
7	6193779M91	4	Secondary Valves	1	Kit, Seal	Pochette de joints	Juego de juntas
8		7	Ref. 7	1	O-Ring	Joint torique	Junta de tipo O
9		7	Ref. 7	1	O-Ring	Joint torique	Junta de tipo O
10		7	Ref. 7	1	O-Ring	Joint torique	Junta de tipo O
11		2	Ref. 2	1	Body	Corps	Cuerpo
12		2	Ref. 2	1	Spool	Tiroir	Cajoncillo
13	6193780M91	2	Mech. Optd Z1	1	Kit, Parts	Lot de pièces	Juego de piezas
14		13	Ref. 13	1	Screw	Vis	Tornillo
15	6193783M91	13	Bellows	1	Kit, Parts	Lot de pièces	Juego de piezas
16		15	Ref. 15	1	Seal	Joint	Junta
17		15	Ref. 15	1	Screw	Vis	Tornillo
18		15	Ref. 15	2	Cover	Cache	Tapa
19		13	Ref. 13	1	Plate	Plaque	Placa
20	6194492M1	13	Lip	1	Seal	Joint	Junta
21	6193784M91	2	Mech Optd A2	1	Kit, Parts	Lot de pièces	Juego de piezas
22	6194492M1	21	Lip	1	Seal	Joint	Junta
23		21	Ref. 21	1	Plate	Plaque	Placa
24		21	Ref. 21	1	Holder	Porte-injecteur	Retén
25		21	Ref. 21	1	Spring	Ressort	Muelle
26		21	Ref. 21	1	Holder	Porte-injecteur	Retén
27		21	Ref. 21	1	Screw	Vis	Tornillo
28		21	Ref. 21	1	Cap	Chapeau	Sombbrero
29		21	Ref. 21	2	Screw	Vis	Tornillo
30	6193785M91	2		1	Plug Assy	Ensemble bouchons	Tapón, Conj.
31		30	Ref. 30	1	Plug	Bouchon	Tapón
32	6193779M91	30	Secondary Valves	1	Kit, Seal	Pochette de joints	Juego de juntas
33		32	Ref. 32	1	O-Ring	Joint torique	Junta de tipo O
34		32	Ref. 32	1	O-Ring	Joint torique	Junta de tipo O
35		32	Ref. 32	1	O-Ring	Joint torique	Junta de tipo O
36	6193792M91	2	Compensator	1	Valve Assy	Ensemble de soupape	Válvula, Conj.
37		36	Ref. 36	1	Plug	Bouchon	Tapón
38		36	Ref. 36	1	O-Ring	Joint torique	Junta de tipo O
39		36	Ref. 36	1	Valve	Soupape	Válvula
40		36	Ref. 36	1	Body	Corps	Cuerpo
41	6193775M91	2	Valve, Check	2	Valve, Check	Clapet anti-retour	Válvula de parada
42		41	Ref. 41	1	Plug	Bouchon	Tapón
43		41	Ref. 41	1	O-Ring	Joint torique	Junta de tipo O
44		41	Ref. 41	1	Spring	Ressort	Muelle

Hydraulic Valve
Distributeur de Commande Hydraulique
Distribuidor de mando hidráulico

Backhoe Control
Godet Rétro
Equipo retro

Auxiliary
Auxiliaire
Auxiliar

Sideshift digger
Sideshift digger
Sideshift digger

C-38001-08.1-A

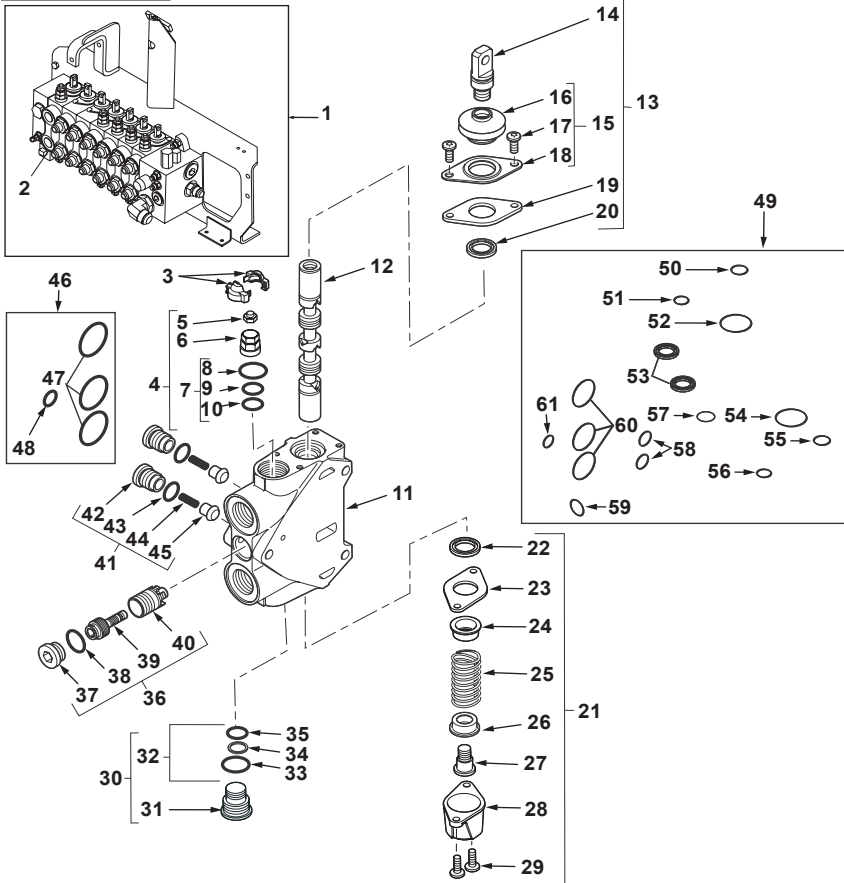

45		41	Ref. 41	1	Valve	Soupape	Válvula
46	6193771M91	2	Interface	1	Kit, Seal	Pochette de joints	Juego de juntas
47		46	(A) Ref. 46	3	O-Ring	Joint torique	Junta de tipo O
48		46	(A) Ref. 46	1	O-Ring	Joint torique	Junta de tipo O
49	6193781M91		(B)	X	Kit, Seal	Pochette de joints	Juego de juntas
50		49	18.77 x 1.78 Ref. 49	1	O-Ring	Joint torique	Junta de tipo O
51		49	15.6 x 1.78 Ref. 49	1	O-Ring	Joint torique	Junta de tipo O
52		49	36.3 x 1.78 Ref. 49	1	O-Ring	Joint torique	Junta de tipo O
53	6194492M1	49	Lip	2	Seal	Joint	Junta
54		49	36.3 x 1.78 Ref. 49	1	O-Ring	Joint torique	Junta de tipo O
55		49	18.77 x 1.78 Ref. 49	1	O-Ring	Joint torique	Junta de tipo O
56		49	15.6 x 1.78 Ref. 49	1	O-Ring	Joint torique	Junta de tipo O
57		49	18 x 2.5 Ref. 49	1	O-Ring	Joint torique	Junta de tipo O
58		49	15 x 2 Ref. 49	2	O-Ring	Joint torique	Junta de tipo O
59		49	19.4 x 2.1 Ref. 49	1	O-Ring	Joint torique	Junta de tipo O
60		49	29.82 x 2.62 Ref. 49	3	O-Ring	Joint torique	Junta de tipo O
61		49	10.77 x 2.62 Ref. 49	1	O-Ring	Joint torique	Junta de tipo O

A Included in kit marked (B)
 Inclus dans jeu marqué (B)
 Incluido en juego marcado (B)

C Part number to be advised
 Référence pièce à demander
 Indicar número de pieza

B Contains items marked (A)
 Comprend les pièces marquées (A)
 Incluye las piezas marcadas (A)



860
TX860B

825

38001C08.1

6199042M3

1

Jan-06

Hydraulic Valve
Distributeur de Commande Hydraulique
Distribuidor de mando hidráulico

Backhoe Control
Godet Rétro
Equipo retro

Outlet
Deversoir
Salida

Sideshift digger
Sideshift digger
Sideshift digger

C-38001-09.1-A

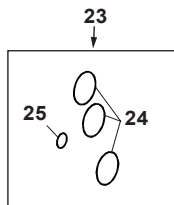
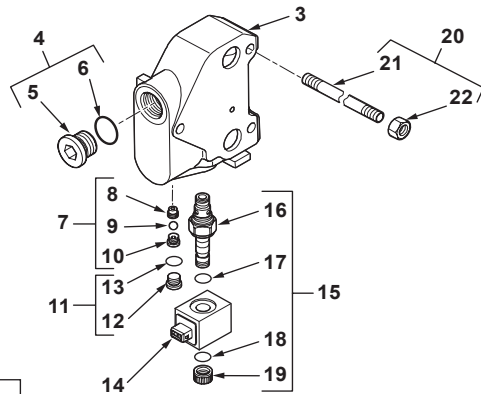
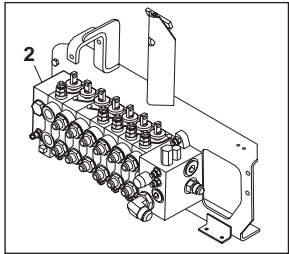

1	6109206M91		Continued	1	Valve Assy, Control	Ensemble distribution	Distribuidor, Conj.
2		1	(A)	1	Valve Assy	Ensemble de soupape	Válvula, Conj.
3		2	Ref. 2	1	Body	Corps	Cuerpo
4	6193773M91	2	1 1/16" UNF	1	Plug Assy	Ensemble bouchons	Tapón, Conj.
5		4	Ref. 4	1	Plug	Bouchon	Tapón
6		4	Ref. 4	1	O-Ring	Joint torique	Junta de tipo O
7	6193793M91	2	Shuttle Throttle	1	Kit, Parts	Lot de pièces	Juego de piezas
8		7	Ref. 7	1	Guide	Guide	Guía
9		7	Ref. 7	1	Ball	Bille	Bola
10		7	Ref. 7	1	Spring	Ressort	Muelle
11	6193795M91	2	9/16" UNF	1	Plug Assy	Ensemble bouchons	Tapón, Conj.
12		11	Ref. 11	1	Plug	Bouchon	Tapón
13		11	Ref. 11	1	O-Ring	Joint torique	Junta de tipo O
14	6193794M1	2		1	Solenoid	Solénoïde	Solenoid
15	6193796M91	2	2 Way	1	Kit, Valve	Jeu de soupapes	Juego de válvulas
16		15	Ref. 15	1	Valve	Soupape	Válvula
17		15	Ref. 15	1	O-Ring	Joint torique	Junta de tipo O
18		15	Ref. 15	1	O-Ring	Joint torique	Junta de tipo O
19		15	Ref. 15	1	Cap	Chapeau	Sombrero
20		1		3	Rod Assy	Ensemble tringlerie	Tirantes, Conj.
21		20	Ref. 20	1	Rod	Tringle	Vástago
22		20	Ref. 20	1	Nut	Écrou	Tuerca
23	6193771M91		Interface	X	Kit, Seal	Pochette de joints	Juego de juntas
24		23	Ref. 23	3	O-Ring	Joint torique	Junta de tipo O
25		23	Ref. 23	1	O-Ring	Joint torique	Junta de tipo O

A Part number to be advised
 Référence pièce à demander
 Indicar número de pieza



860
 TX860B

825

38001C09.1

6199042M3

1

Jan-06

Hydraulic Valve
Distributeur de Commande Hydraulique
Distribuidor de mando hidráulico

Backhoe Control
Godet Rétro
Equipo retro

Sideshift digger installation
 Installation montage de pelle latéral
 La Instalación excavadora de montaje horizontal

C-38003-01.1-A

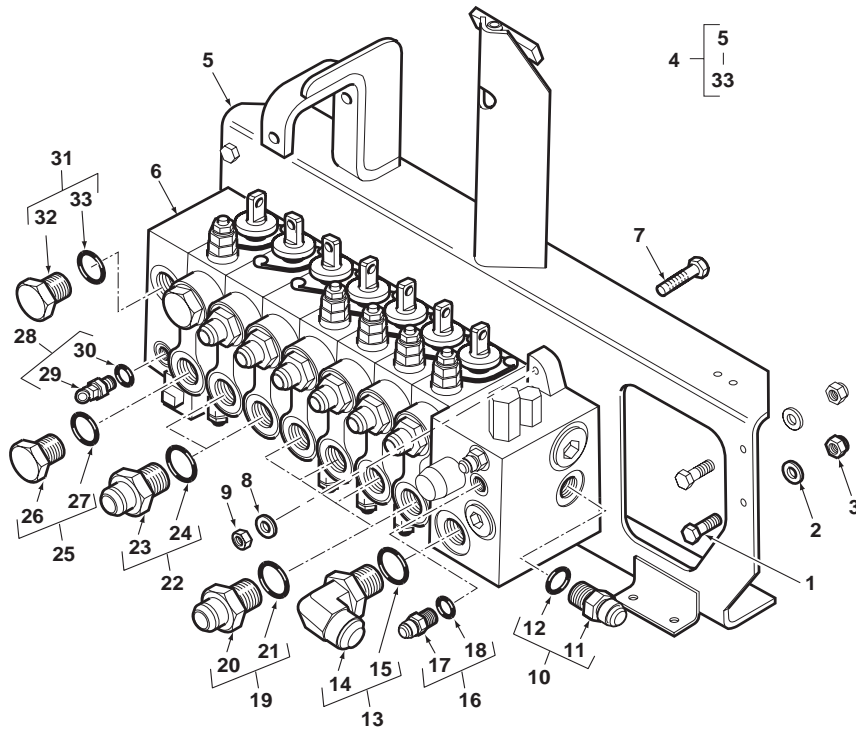

1	3009493X1	M10 x 30	4	Bolt	Boulon	Perno
2	385362X1	M10	4	Washer	Rondelle	Arandela
3	1440329X1	M10	4	Nut, Lock	Écrou de blocage	Tuerca de retención
4	6110435M91		1	Valve Assy, Control	Ensemble distribution	Distribuidor, Conj.
5	6109344M92	4	1	Bracket Assy	Ensemble chaise palier	Cuchara, Conj.
6	6109206M91	4 (A)	1	Valve Assy, Control	Ensemble distribution	Distribuidor, Conj.
7	3009496X1	4 M10 x 45	3	Screw	Vis	Tornillo
8	385362X1	4 M10	3	Washer	Rondelle	Arandela
9	1440329X1	4 M10	3	Nut, Lock	Écrou de blocage	Tuerca de retención
10	835057M91	4	1	Connector Assy	Ensemble connexion	Conexión, Conj.
11	10	➡ Ref. 10	1	Union	Union	Unión
12	835025M1	10	1	O-Ring	Joint torique	Junta de tipo O
13	358766X91	4	1	Elbow, 90°	Coude à 90°	Codo, 90°
14	13	➡ Ref. 13	1	Elbow	Coude	Codo
15	835026M1	13	1	O-Ring	Joint torique	Junta de tipo O
16	835091M91	4 9/16	2	Union	Union	Unión
17	16	➡ Ref. 16	1	O-Ring	Union	Unión
18	831452M1	16	1	O-Ring	Joint torique	Junta de tipo O
19	365715X91	4 1,1/16" - 7/8" UNF	8	Connector Assy	Ensemble connexion	Conexión, Conj.
20	19	➡ Ref. 19	1	Union	Union	Unión
21	835025M1	19	1	O-Ring	Joint torique	Junta de tipo O
22	365713X91	4	4	Union	Union	Unión
23	22	➡ Ref. 22	1	Union	Union	Unión
24	835025M1	22	1	O-Ring	Joint torique	Junta de tipo O
25	835099M91	4	2	Plug Assy	Ensemble bouchons	Tapón, Conj.
26	25	➡ Ref. 25	1	Plug	Bouchon	Tapón
27	835025M1	25	1	O-Ring	Joint torique	Junta de tipo O
28	358781X91	4	1	Elbow, 45°	Coude à 45°	Codo, 45°
29	28	➡ Ref. 28	1	Elbow	Coude	Codo
30	831452M1	28	1	O-Ring	Joint torique	Junta de tipo O
31	835099M91	4	1	Plug Assy	Ensemble bouchons	Tapón, Conj.
32	31	➡ Ref. 31	1	Plug	Bouchon	Tapón
33	835025M1	31	1	O-Ring	Joint torique	Junta de tipo O

A Without Auxiliary Hydraulics
 Sans Hydraulique Auxiliaire
 Sin hidraulico auxiliar



820 860 880 970
 TX760B TX860B

805 806 807 808 817 825 845 921

38003C01.1

6199042M3

1

Jan-06

Hydraulic Valve
Distributeur de Commande Hydraulique
Distribuidor de mando hidráulico

Backhoe Control
Godet Rétro
Equipo retro

Sideshift digger installation
 Installation montage de pelle latéral
 La Instalación excavadora de montaje horizontal

C-38003-02.1-A

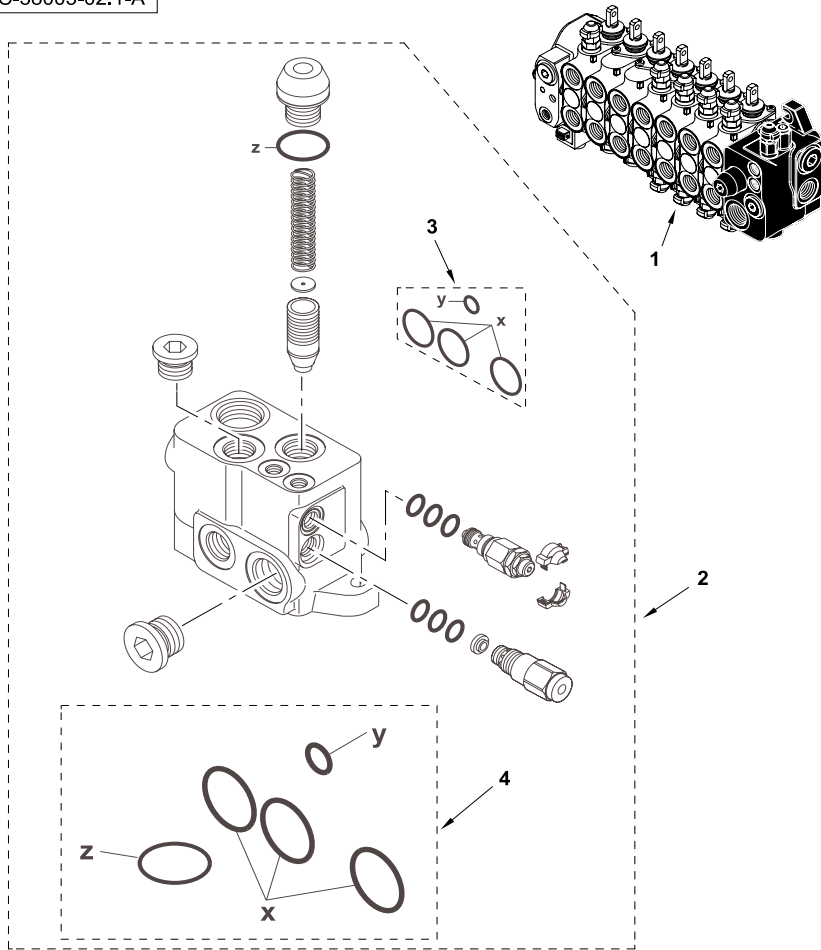

1	6109206M91		1	Valve Assy, Control	Ensemble distribution	Distribuidor, Conj.
2	6194534M91		1	Element - Inlet		
3	6193771M91	Interface	1	Kit, Seal	Pochette de joints	Juego de juntas
4	6193789M91	Inlet element	1	Kit, Seal	Pochette de joints	Juego de juntas



820 860 880 970
 TX760B TX860B

805 806 807 808 817 825 845 921

38003C02.1

6199042M3

1

Jan-06

Hydraulic Valve
Distributeur de Commande Hydraulique
Distribuidor de mando hidráulico

Backhoe Control
Godet Rétro
Equipo retro

Sideshift digger installation
 Installation montage de pelle latéral
 La Instalación excavadora de montaje horizontal

C-38003-03.1-A

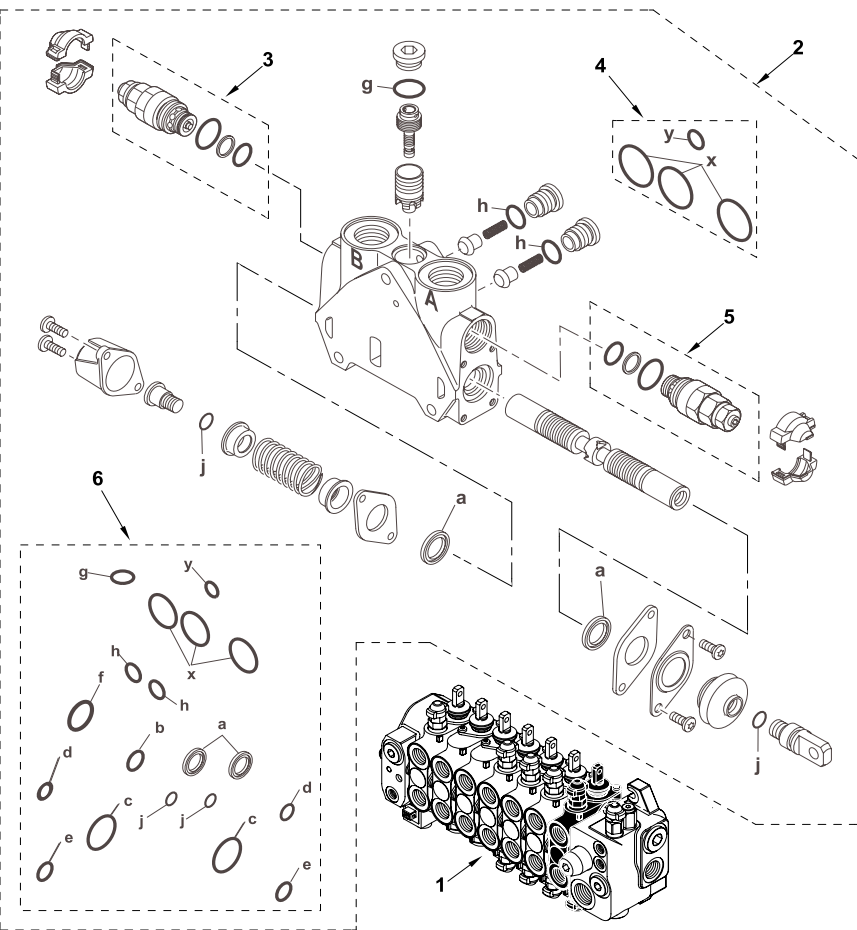

1	6109206M91		1	Valve Assy, Control	Ensemble distribution	Distribuidor, Conj.
2	6194519M91		1	Element - Slew		
3	6193800M91		1	240 Bar PRV		
4	6193771M91	Interface	1	Kit, Seal	Pochette de joints	Juego de juntas
5	6193800M91		1	240 Bar PRV		
6	6193789M91	Inlet element	1	Kit, Seal	Pochette de joints	Juego de juntas



820 860 880 970
 TX760B TX860B

805 806 807 808 817 825 845 921

38003C03.1

6199042M3

1

Jan-06

Hydraulic Valve
Distributeur de Commande Hydraulique
Distribuidor de mando hidráulico

Backhoe Control
Godet Rétro
Equipo retro

Sideshift digger installation
 Installation montage de pelle latéral
 La Instalación excavadora de montaje horizontal

C-38003-04.1-A

1	6109206M91		1	Valve Assy, Control	Ensemble distribution	Distribuidor, Conj.
2	6194520M91		1	Element - Boom		
3	6193804M91		1	310 Bar PRV		
4	6193771M91	Interface	1	Kit, Seal	Pochette de joints	Juego de juntas
5	6193800M91		1	240 Bar PRV		
6	6193781M91		1	Kit, Seal	Pochette de joints	Juego de juntas

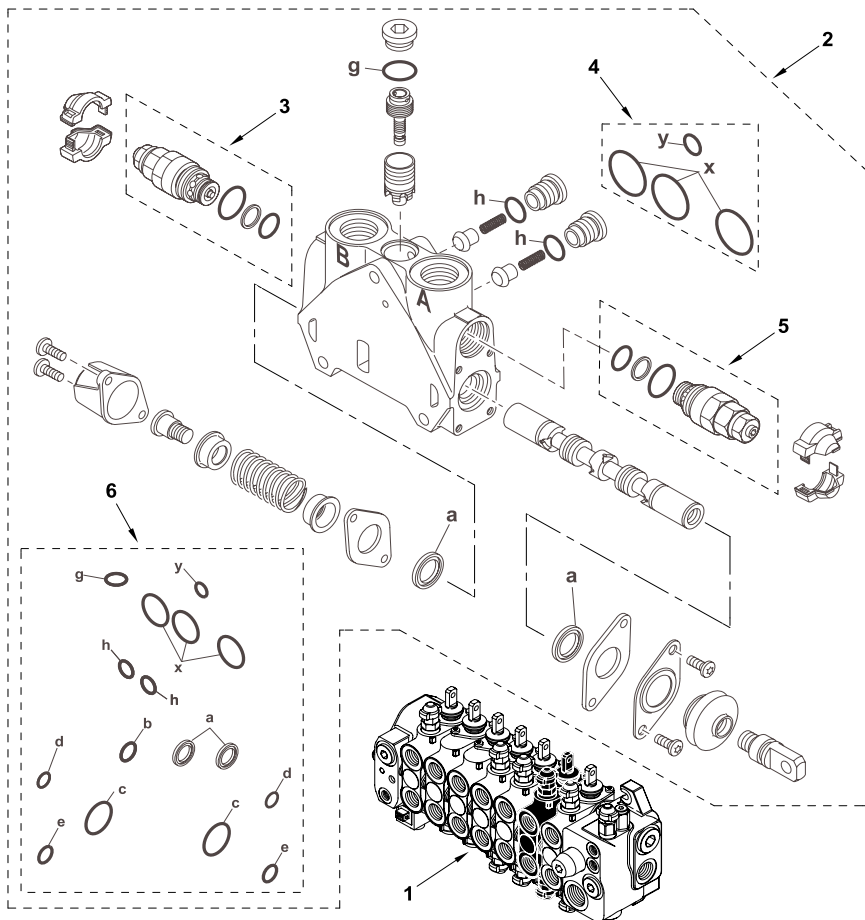

820 860 880 970
 TX760B TX860B

805 806 807 808 817 825 845 921

38003C04.1

6199042M3

1

Jan-06

Hydraulic Valve
Distributeur de Commande Hydraulique
Distribuidor de mando hidráulico

Backhoe Control
Godet Rétro
Equipo retro

Sideshift digger installation
 Installation montage de pelle latéral
 La Instalación excavadora de montaje horizontal

C-38003-05.1-A

1	6109206M91		1	Valve Assy, Control	Ensemble distribution	Distribuidor, Conj.
2	61934521M91		1	Element - Dipper		
3	6193802M91		1	265 Bar PRV		
4	6193771M91	Interface	1	Kit, Seal	Pochette de joints	Juego de juntas
5	6193808M91		1	280 Bar PRV		
6	6193781M91		1	Kit, Seal	Pochette de joints	Juego de juntas

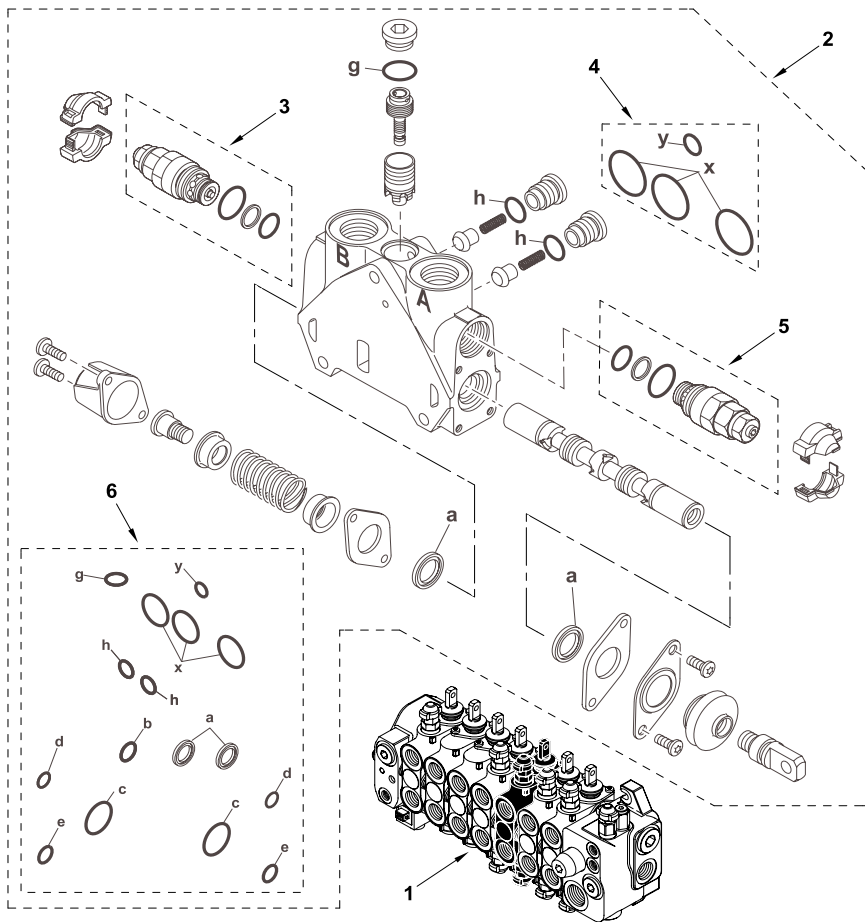

820 860 880 970
 TX760B TX860B

805 806 807 808 817 825 845 921

38003C05.1

6199042M3

1

Jan-06

Hydraulic Valve
Distributeur de Commande Hydraulique
Distribuidor de mando hidráulico

Backhoe Control
Godet Rétro
Equipo retro

Sideshift digger installation
 Installation montage de pelle latéral
 La Instalación excavadora de montaje horizontal

C-38003-06.1-A

1	6109206M91		1	Valve Assy, Control	Ensemble distribution	Distribuidor, Conj.
2	6194522M91		1	Element - Bucket		
3	6193805M91		1	280 Bar PRV		
4	6193771M91	Interface	1	Kit, Seal	Pochette de joints	Juego de juntas
5	6193805M91		1	280 Bar PRV		
6	6193781M91		1	Kit, Seal	Pochette de joints	Juego de juntas

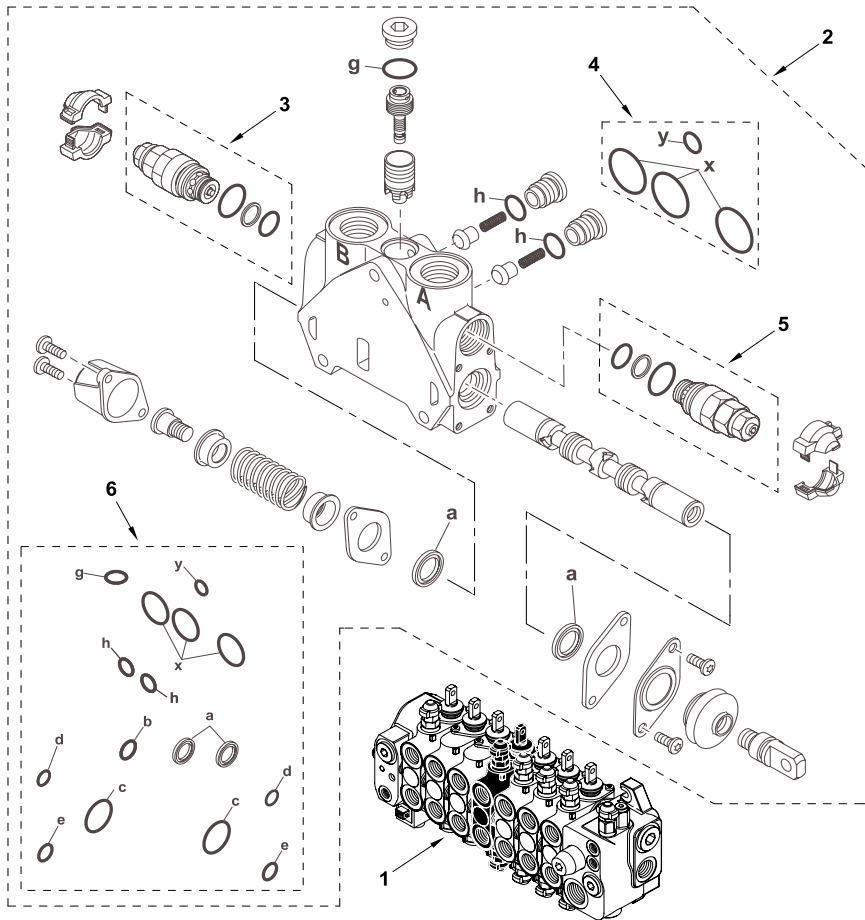

820 860 880 970
 TX760B TX860B

805 806 807 808 817 825 845 921

38003C06.1

6199042M3

1

Jan-06

Hydraulic Valve
Distributeur de Commande Hydraulique
Distribuidor de mando hidráulico

Backhoe Control
Godet Rétro
Equipo retro

Sideshift digger installation
 Installation montage de pelle latéral
 La Instalación excavadora de montaje horizontal

C-38003-07.1-A

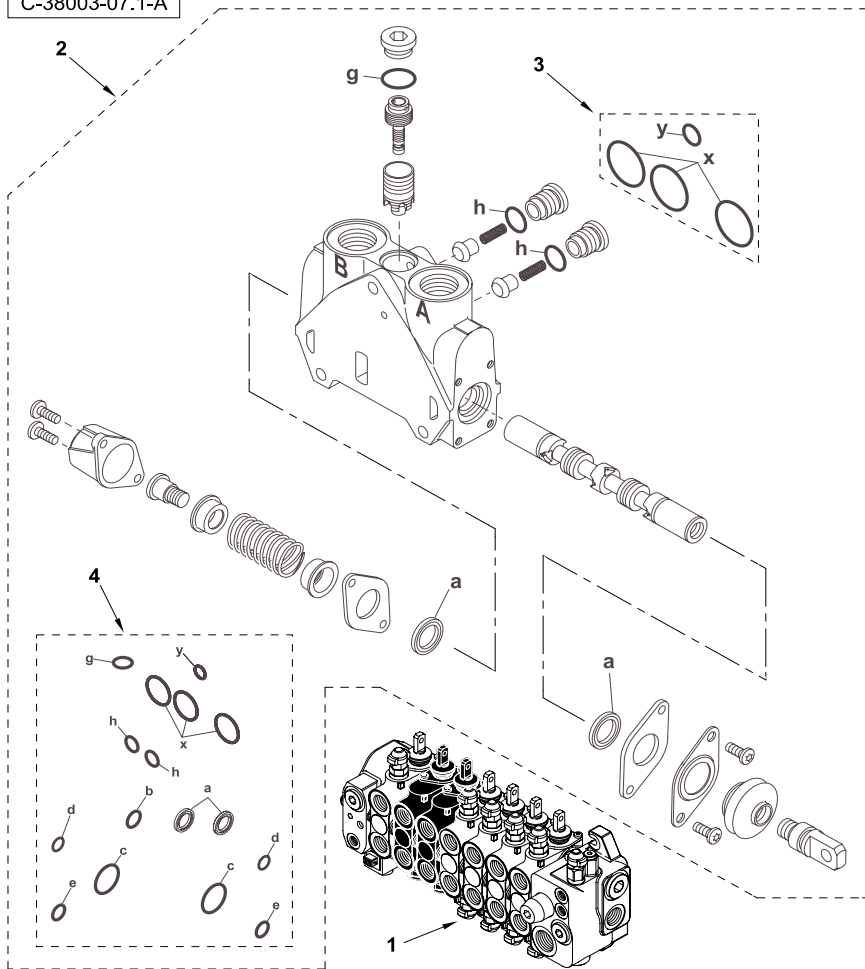

1	6109206M91		1	Valve Assy, Control	Ensemble distribution	Distribuidor, Conj.
2	6194523M91		1	Element - Stabiliser		
3	6193771M91	Interface	1	Kit, Seal	Pochette de joints	Juego de juntas
4	6193781M91		1	Kit, Seal	Pochette de joints	Juego de juntas



820 860 880 970
 TX760B TX860B

805 806 807 808 817 825 845 921

Hydraulic Valve
Distributeur de Commande Hydraulique
Distribuidor de mando hidráulico

Backhoe Control
Godet Rétro
Equipo retro

Sideshift digger installation
 Installation montage de pelle latéral
 La Instalación excavadora de montaje horizontal

C-38003-08.1-A

1	6109206M91		1	Valve Assy, Control	Ensemble distribution	Distribuidor, Conj.
2	6194524M91		1	Element - Telescope		
3	6193785M91		1	Plug Assy	Ensemble bouchons	Tapón, Conj.
4	6193771M91	Interface	1	Kit, Seal	Pochette de joints	Juego de juntas
5	6193799M91		1	155 Bar PRV		
6	6193781M91		1	Kit, Seal	Pochette de joints	Juego de juntas

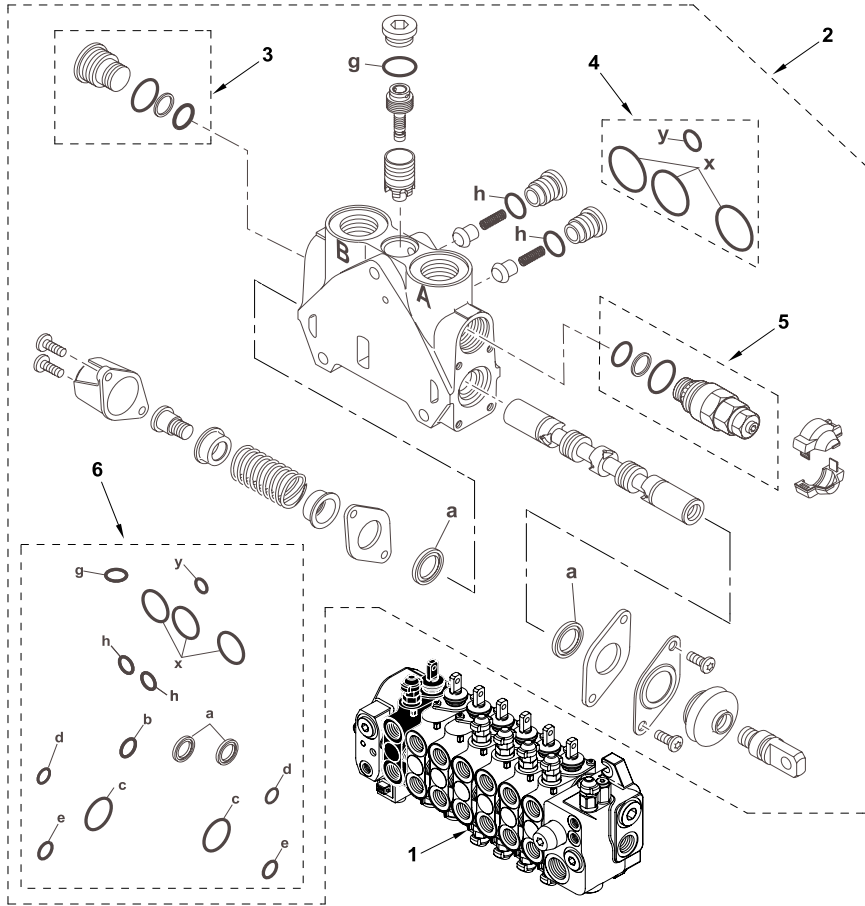

820 860 880 970
 TX760B TX860B

805 806 807 808 817 825 845 921

38003C08.1

6199042M3

1

Jan-06

Hydraulic Valve
Distributeur de Commande Hydraulique
Distribuidor de mando hidráulico

Backhoe Control
Godet Rétro
Equipo retro

Sideshift digger installation
 Installation montage de pelle latéral
 La Instalación excavadora de montaje horizontal

C-38003-09.1-A

1	6109206M91		1	Valve Assy, Control	Ensemble distribution	Distribuidor, Conj.
2	6194513M91		1	Element - Outlet		
3	6193771M91	Interface	1	Kit, Seal	Pochette de joints	Juego de juntas

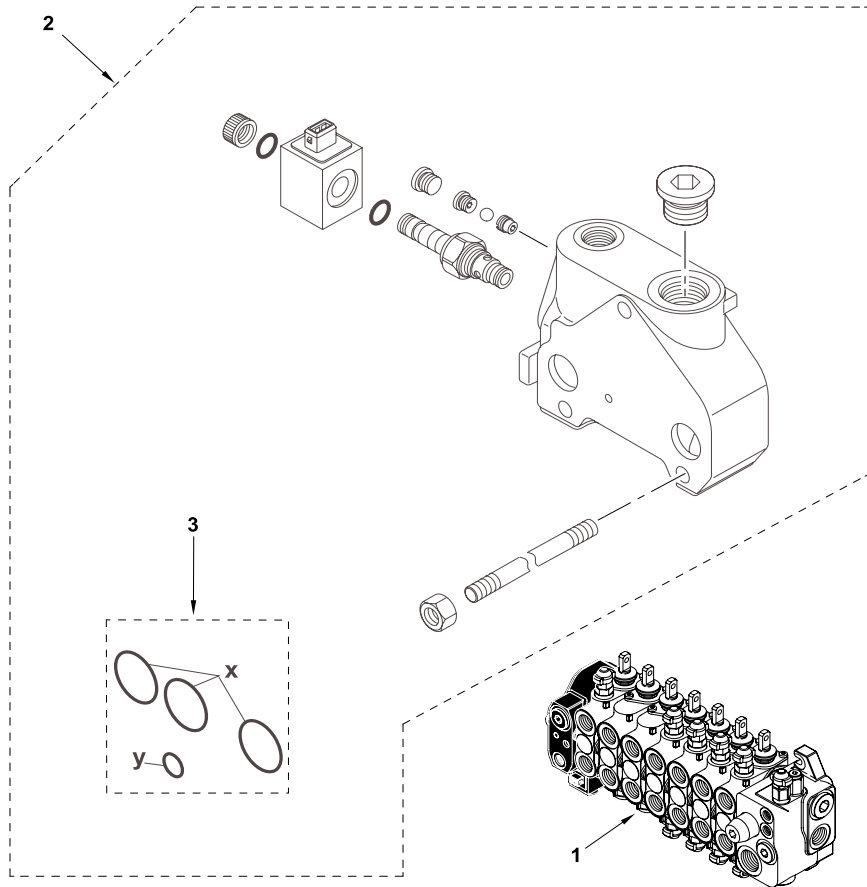

820 860 880 970
 TX760B TX860B

805 806 807 808 817 825 845 921

38003C09.1

6199042M3

1

Jan-06

Hydraulic Valve
Distributeur de Commande Hydraulique
Distribuidor de mando hidráulico

Backhoe Control
Godet Rétro
Equipo retro

Centre mounted digger installation
 Installation montage de pelle central
 La Instalación excavadora de montaje central

C-38004-01.1-A

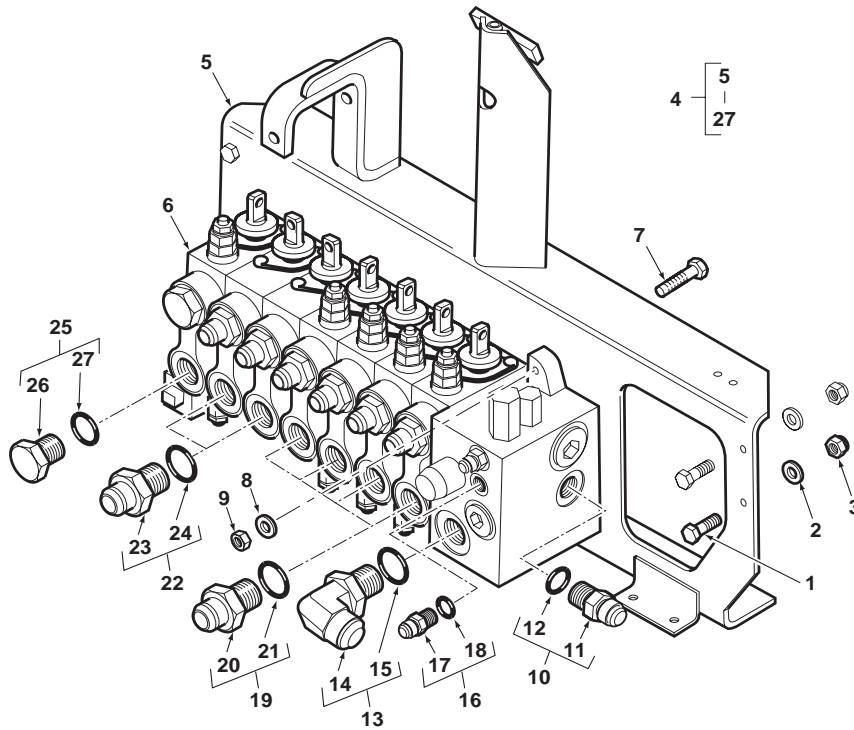

1	3009493X1	M10 x 30	4	Bolt	Boulon	Perno
2	385362X1	M10	4	Washer	Rondelle	Arandela
3	1440329X1	M10	4	Nut, Lock	Écrou de blocage	Tuerca de retención
4	6110436M91	(A)	1	Valve Assy, Control	Ensemble distribution	Distribuidor, Conj.
5	6109344M92	4	1	Bracket Assy	Ensemble chaise palier	Cuchara, Conj.
6	6109457M91	4	1	Valve Assy, Control	Ensemble distribution	Distribuidor, Conj.
7	3009496X1	4 M10 x 45	3	Screw	Vis	Tornillo
8	385362X1	4 M10	3	Washer	Rondelle	Arandela
9	1440329X1	4 M10	3	Nut, Lock	Écrou de blocage	Tuerca de retención
10	835057M91	4	1	Connector Assy	Ensemble connexion	Conexión, Conj.
11	10	➡ Ref. 10	1	Union	Union	Unión
12	835025M1	10	1	O-Ring	Joint torique	Junta de tipo O
13	358766X91	4	1	Elbow, 90°	Coude à 90°	Codo, 90°
14	13	➡ Ref. 13	1	Elbow	Coude	Codo
15	835026M1	13	1	O-Ring	Joint torique	Junta de tipo O
16	835091M91	4 9/16	2	Union	Union	Unión
17	16	➡ Ref. 16	1	Union	Union	Unión
18	831452M1	16	1	O-Ring	Joint torique	Junta de tipo O
19	365715X91	4 1,1/16" - 7/8" UNF	8	Connector Assy	Ensemble connexion	Conexión, Conj.
20	19	➡ Ref. 19	1	Union	Union	Unión
21	835025M1	19	1	O-Ring	Joint torique	Junta de tipo O
22	365713X91	4	4	Union	Union	Unión
23	22	➡ Ref. 22	1	Union	Union	Unión
24	835025M1	22	1	O-Ring	Joint torique	Junta de tipo O
25	835099M91	4	2	Plug Assy	Ensemble bouchons	Tapón, Conj.
26	25	➡ Ref. 25	1	Plug	Bouchon	Tapón
27	835025M1	25	1	O-Ring	Joint torique	Junta de tipo O

A Without Auxiliary Hydraulics
 Sans Hydraulique Auxiliaire
 Sin hidraulico auxiliar



820 860 970
 TX760B TX860B
 TX870B

802 803 804 809 810 811 812 813 814 815 816 821 822 823 824 831 922 923

38004C01.1

6199042M3

1

Jan-06

Hydraulic Valve
Distributeur de Commande Hydraulique
Distribuidor de mando hidráulico

Backhoe Control
Godet Rétro
Equipo retro

Centre mounted digger installation
 Installation montage de pelle central
 La Instalación excavadora de montaje central

C-38004-02.1-A

1	6109457M91		1	Valve Assy, Control	Ensemble distribution	Distribuidor, Conj.
2	6194534M91		1	Element - Inlet		
3	6193771M91	Interface	1	Kit, Seal	Pochette de joints	Juego de juntas
4	6193789M91	Inlet element	1	Kit, Seal	Pochette de joints	Juego de juntas

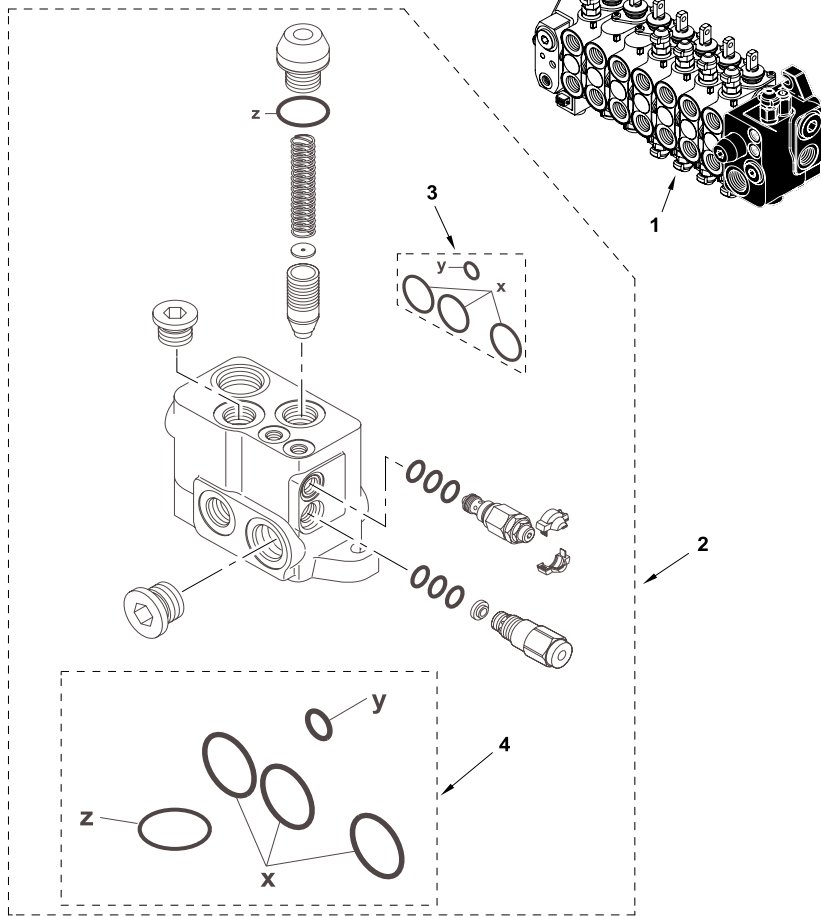

820 860 970
 TX760B TX860B
 TX870B

802 803 804 809 810 811 812 813 814 815 816 821 822 823 824 831 922 923

38004C02.1

6199042M3

1

Jan-06

Hydraulic Valve
Distributeur de Commande Hydraulique
Distribuidor de mando hidráulico

Backhoe Control
Godet Rétro
Equipo retro

Centre mounted digger installation
 Installation montage de pelle central
 La Instalación excavadora de montaje central

C-38004-03.1-A

1	6109457M91		1	Valve Assy, Control	Ensemble distribution	Distribuidor, Conj.
2	6194519M91		1	Element - Slew		
3	6193800M91		1	240 Bar PRV		
4	6193771M91	Interface	1	Kit, Seal	Pochette de joints	Juego de juntas
5	6193800M91		1	240 Bar PRV		
6	6194518M91		1	Kit, Seal	Pochette de joints	Juego de juntas

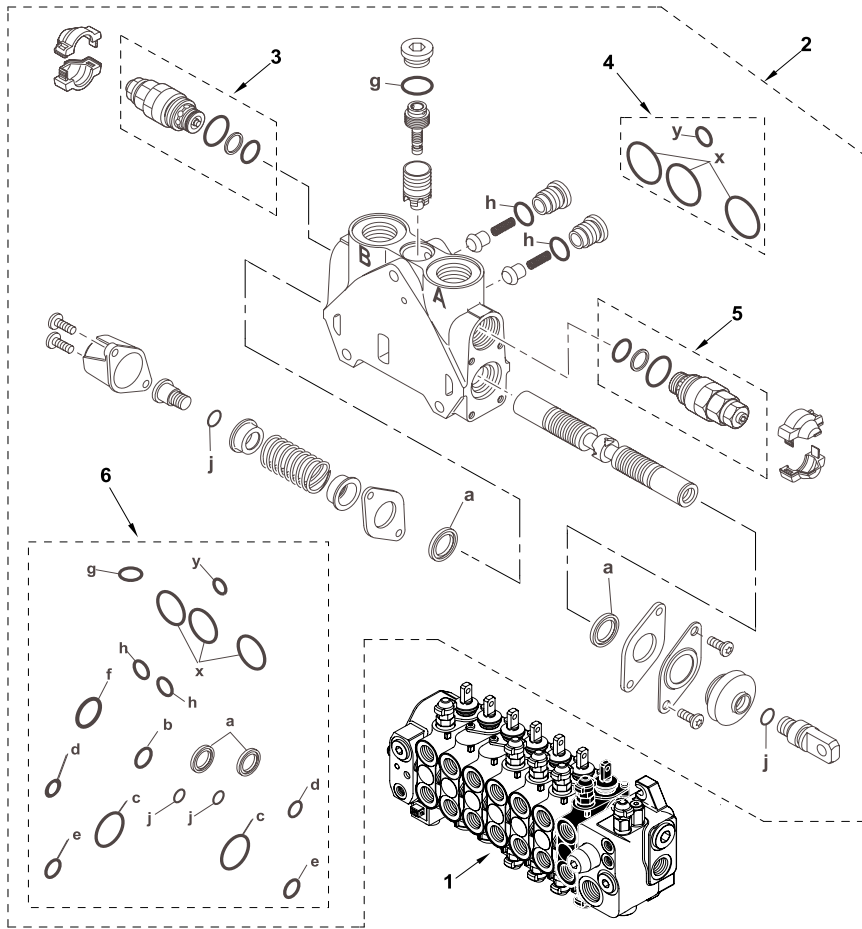

820 860 970
 TX760B TX860B
 TX870B

802 803 804 809 810 811 812 813 814 815 816 821 822 823 824 831 922 923

38004C03.1

6199042M3

1

Jan-06

Hydraulic Valve
Distributeur de Commande Hydraulique
Distribuidor de mando hidráulico

Backhoe Control
Godet Rétro
Equipo retro

Centre mounted digger installation
 Installation montage de pelle central
 La Instalación excavadora de montaje central

C-38004-04.1-A

1	6109457M91		1	Valve Assy, Control	Ensemble distribution	Distribuidor, Conj.
2	6194520M91		1	Element - Boom		
3	6193804M91		1	310 Bar PRV		
4	6193771M91	Interface	1	Kit, Seal	Pochette de joints	Juego de juntas
5	6193799M91		1	155 Bar PRV		
6	6193781M91		1	Kit, Seal	Pochette de joints	Juego de juntas

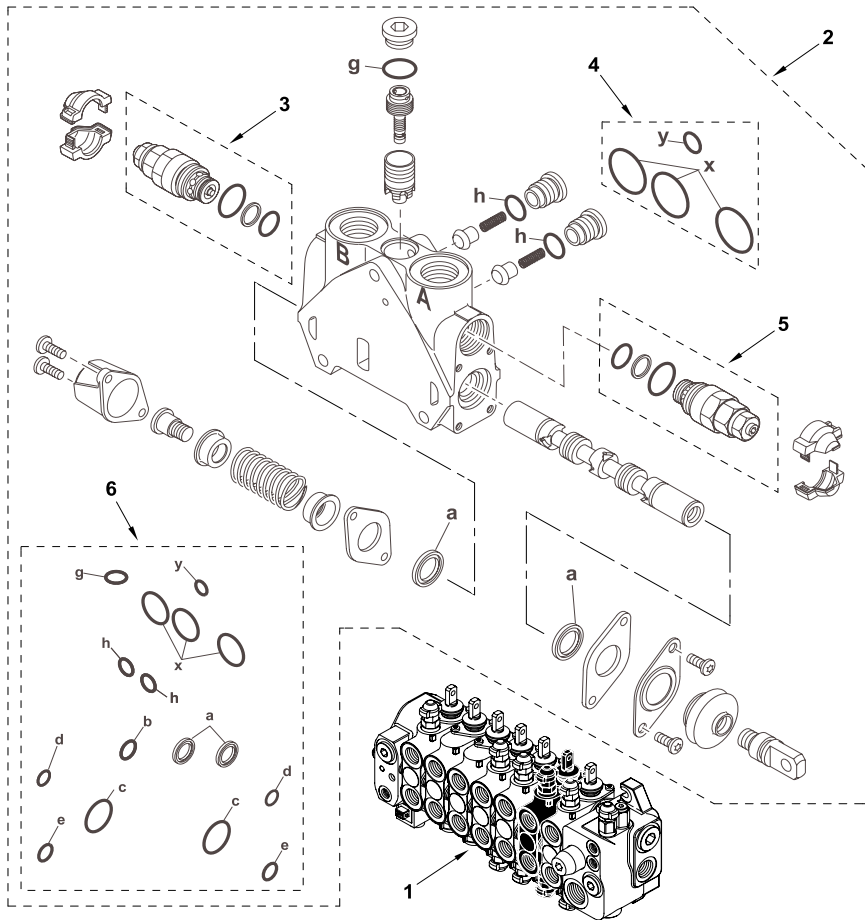

820 860 970
 TX760B TX860B
 TX870B

802 803 804 809 810 811 812 813 814 815 816 821 822 823 824 831 922 923

38004C04.1

6199042M3

1

Jan-06

Hydraulic Valve
Distributeur de Commande Hydraulique
Distribuidor de mando hidráulico

Backhoe Control
Godet Rétro
Equipo retro

Centre mounted digger installation
 Installation montage de pelle central
 La Instalación excavadora de montaje central

C-38004-05.1-A

1	6109457M91		1	Valve Assy, Control	Ensemble distribution	Distribuidor, Conj.
2	6194521M91		1	Element - Dipper		
3	6193802M91		1	265 Bar PRV		
4	6193771M91	Interface	1	Kit, Seal	Pochette de joints	Juego de juntas
5	6193808M91		1	280 Bar PRV		
6	6193781M91		1	Kit, Seal	Pochette de joints	Juego de juntas

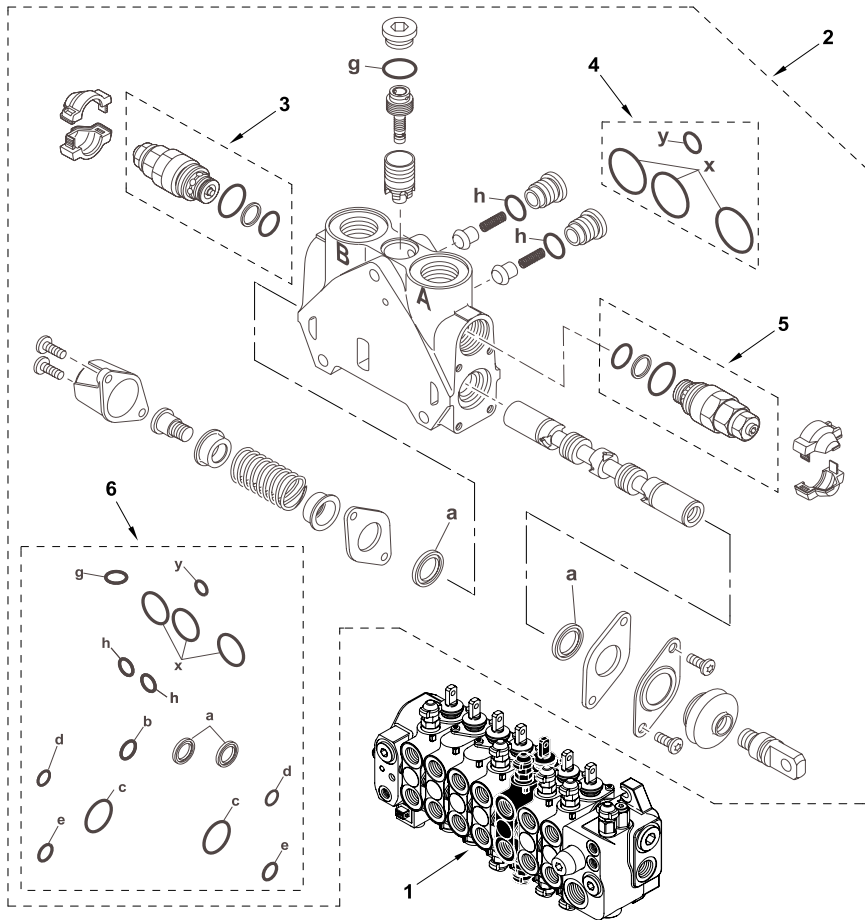

820 860 970
 TX760B TX860B
 TX870B

802 803 804 809 810 811 812 813 814 815 816 821 822 823 824 831 922 923

38004C05.1

6199042M3

1

Jan-06

Hydraulic Valve
Distributeur de Commande Hydraulique
Distribuidor de mando hidráulico

Backhoe Control
Godet Rétro
Equipo retro

Centre mounted digger installation
 Installation montage de pelle central
 La Instalación excavadora de montaje central

C-38004-06.1-A

1	6109457M91		1	Valve Assy, Control	Ensemble distribution	Distribuidor, Conj.
2	6194522M91		1	Element - Bucket		
3	6193805M91		1	280 Bar PRV		
4	6193771M91	Interface	1	Kit, Seal	Pochette de joints	Juego de juntas
5	6193805M91		1	280 Bar PRV		
6	6193781M91		1	Kit, Seal	Pochette de joints	Juego de juntas

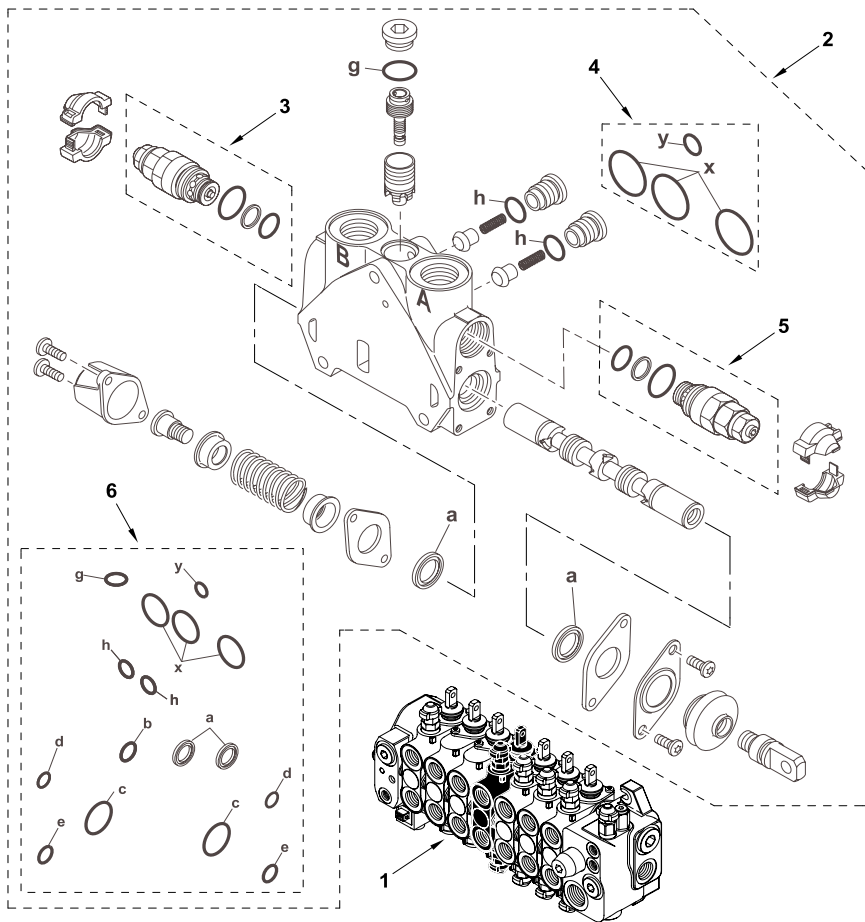

820 860 970
 TX760B TX860B
 TX870B

802 803 804 809 810 811 812 813 814 815 816 821 822 823 824 831 922 923

38004C06.1

6199042M3

1

Jan-06

Hydraulic Valve
Distributeur de Commande Hydraulique
Distribuidor de mando hidráulico

Backhoe Control
Godet Rétro
Equipo retro

Centre mounted digger installation
 Installation montage de pelle central
 La Instalación excavadora de montaje central

C-38004-07.1-A

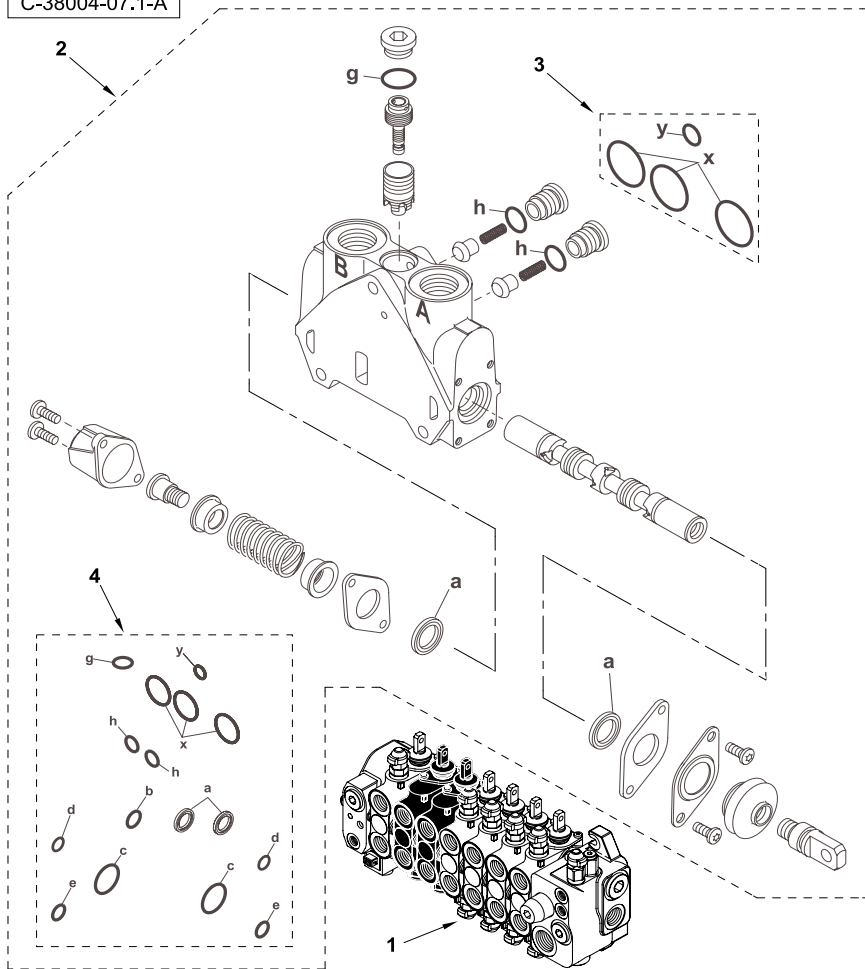

1	6109457M91		1	Valve Assy, Control	Ensemble distribution	Distribuidor, Conj.
2	6194523M91		1	Element - Stabiliser		
3	6193771M91	Interface	1	Kit, Seal	Pochette de joints	Juego de juntas
4	6193781M91		1	Kit, Seal	Pochette de joints	Juego de juntas



820 860 970
 TX760B TX860B
 TX870B

802 803 804 809 810 811 812 813 814 815 816 821 822 823 824 831 922 923

38004C07.1

6199042M3

1

Jan-06

Hydraulic Valve
Distributeur de Commande Hydraulique
Distribuidor de mando hidráulico

Backhoe Control
Godet Rétro
Equipo retro

Centre mounted digger installation
 Installation montage de pelle central
 La Instalación excavadora de montaje central

C-38004-08.1-A

1	6109457M91		1	Valve Assy, Control	Ensemble distribution	Distribuidor, Conj.
2	6194524M91		1	Element - Telescope		
3	6193785M91		1	Plug Assy	Ensemble bouchons	Tapón, Conj.
4	6193771M91	Interface	1	Kit, Seal	Pochette de joints	Juego de juntas
5	6193799M91		1	155 Bar PRV		
6	6193781M91		1	Kit, Seal	Pochette de joints	Juego de juntas

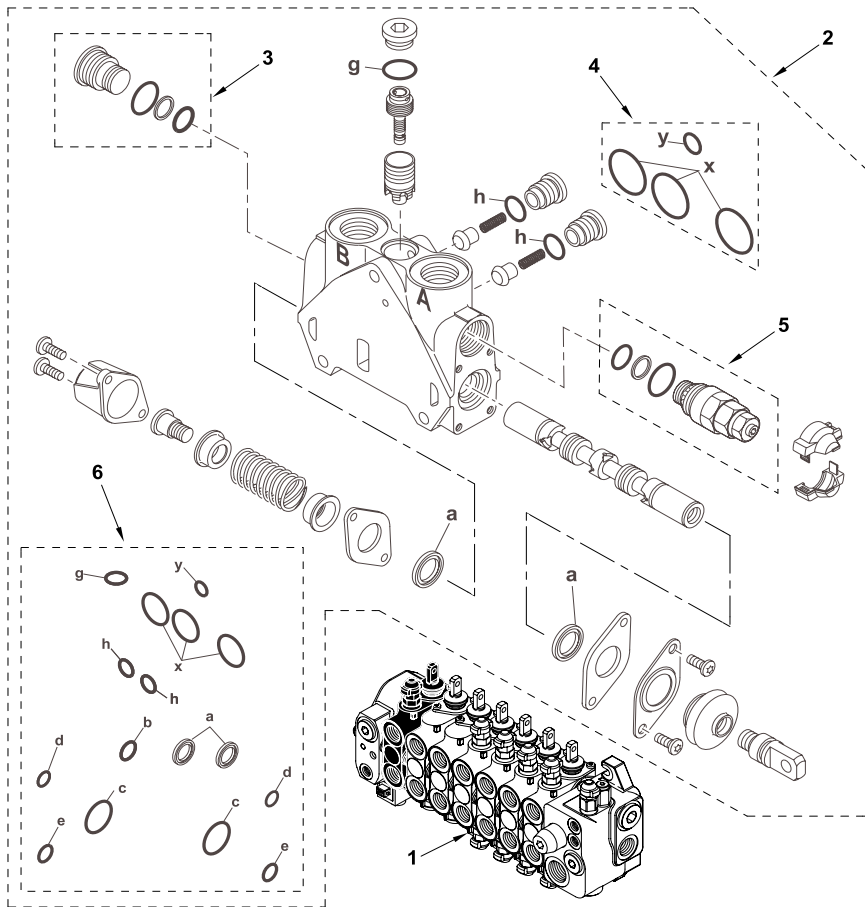

820 860 970
 TX760B TX860B
 TX870B

802 803 804 809 810 811 812 813 814 815 816 821 822 823 824 831 922 923

38004C08.1

6199042M3

1

Jan-06

Hydraulic Valve
Distributeur de Commande Hydraulique
Distribuidor de mando hidráulico

Backhoe Control
Godet Rétro
Equipo retro

Centre mounted digger installation
 Installation montage de pelle central
 La Instalación excavadora de montaje central

C-38004-09.1-A

1	6109457M91		1	Valve Assy, Control	Ensemble distribution	Distribuidor, Conj.
2	6194516M91		1	Element - Outlet		
3	6193771M91	Interface	1	Kit, Seal	Pochette de joints	Juego de juntas

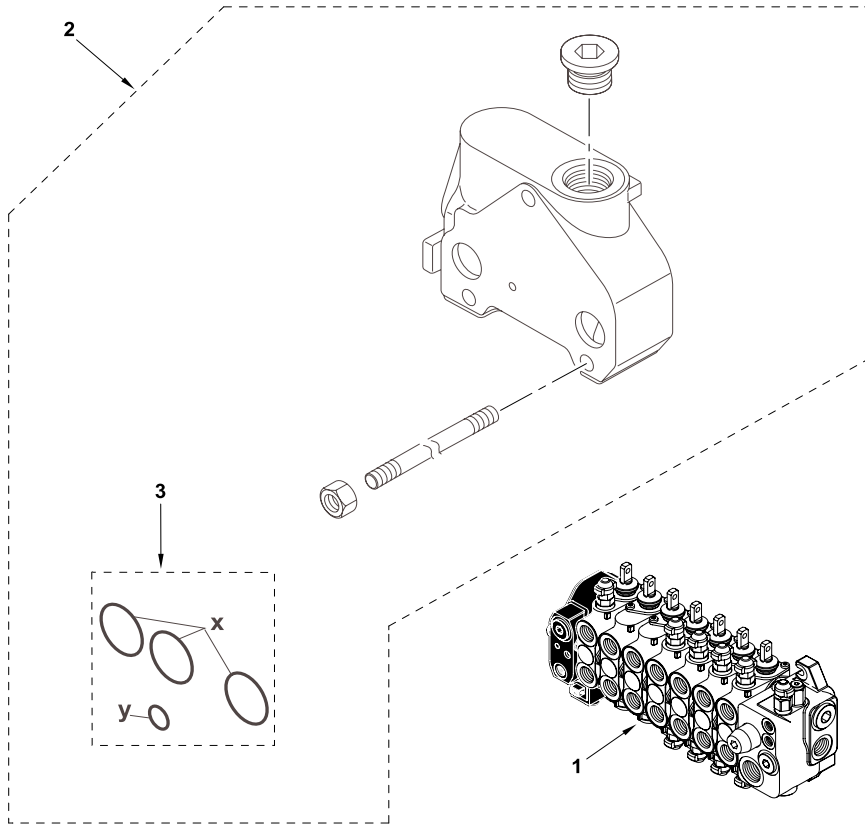

820 860 970
 TX760B TX860B
 TX870B

802 803 804 809 810 811 812 813 814 815 816 821 822 823 824 831 922 923

38004C09.1

6199042M3

1

Jan-06

Hydraulic Valve
Distributeur de Commande Hydraulique
Distribuidor de mando hidráulico

Backhoe Control
Godet Rétro
Equipo retro

Centre mounted digger installation
 Installation montage de pelle central
 La Instalación excavadora de montaje central

Servo
 Servo
 Servo

C-38007-01.1-A

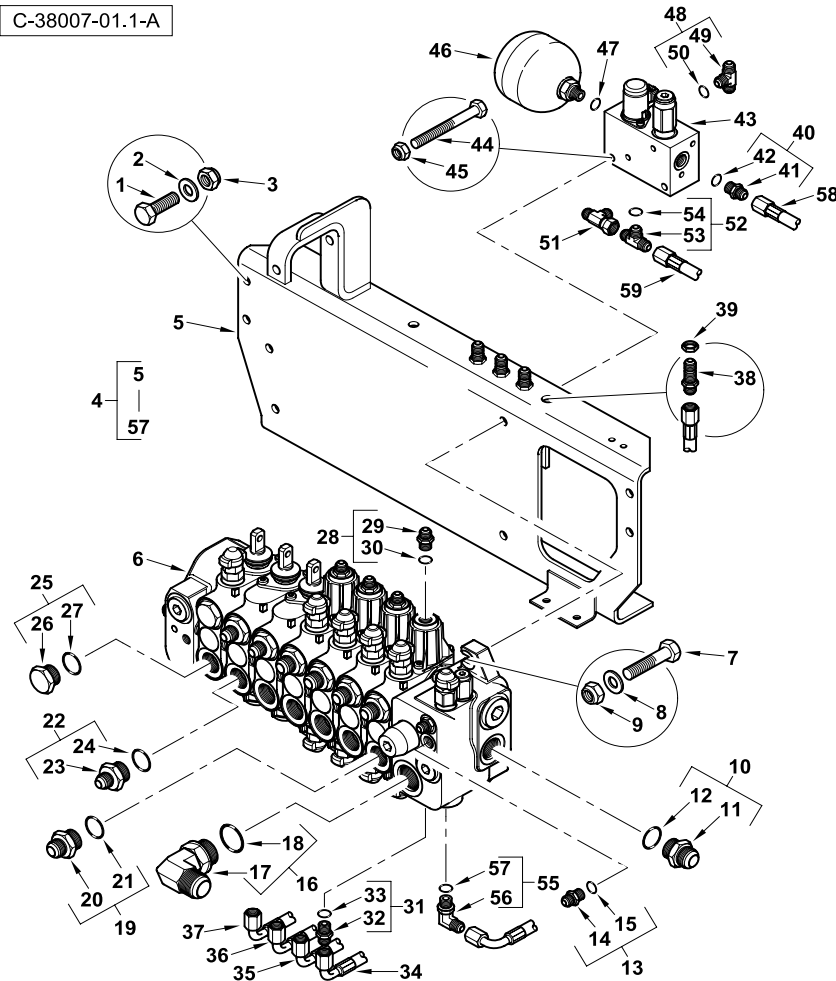

1	3009493X1	M10 x 30	4	Bolt	Boulon	Perno
2	385362X1	M10	4	Washer	Rondelle	Arandela
3	1440329X1	M10	4	Nut, Lock	Écrou de blocage	Tuerca de retención
4	6110922M91	(A)	1	Valve Assy, Control	Ensemble distribution	Distribuidor, Conj.
5	6110773M91	4	1	Bracket Assy	Ensemble chaise palier	Cuchara, Conj.
6	6110917M91	4	1	Valve Assy, Control	Ensemble distribution	Distribuidor, Conj.
7	3009496X1	4 M10 x 45	3	Screw	Vis	Tornillo
8	385362X1	4 M10	3	Washer	Rondelle	Arandela
9	1440329X1	4 M10	3	Nut, Lock	Écrou de blocage	Tuerca de retención
10	835057M91	4	1	Connector Assy	Ensemble connexion	Conexión, Conj.
11		Ref. 10	1	Union	Union	Unión
12	835025M1	10	1	O-Ring	Joint torique	Junta de tipo O
13	835091M91	4 9/16	2	Union	Union	Unión
14		Ref. 13	1	Union	Union	Unión
15	831452M1	13	1	O-Ring	Joint torique	Junta de tipo O
16	358766X91	4	1	Elbow, 90°	Coude à 90°	Codo, 90°
17		Ref. 16	1	Elbow	Coude	Codo
18	835026M1	16	1	O-Ring	Joint torique	Junta de tipo O
19	365715X91	4 1,1/16" - 7/8" UNF	8	Connector Assy	Ensemble connexion	Conexión, Conj.
20		Ref. 19	1	Union	Union	Unión
21	835025M1	19	1	O-Ring	Joint torique	Junta de tipo O
22	365713X91	4	4	Union	Union	Unión
23		Ref. 22	1	Union	Union	Unión
24	835025M1	22	1	O-Ring	Joint torique	Junta de tipo O
25	835099M91	4	2	Plug Assy	Ensemble bouchons	Tapón, Conj.
26		Ref. 25	1	Plug	Bouchon	Tapón
27	835025M1	25	1	O-Ring	Joint torique	Junta de tipo O
28	835091M91	4 9/16	4	Union	Union	Unión
29		Ref. 28	1	Union	Union	Unión
30	831452M1	28	1	O-Ring	Joint torique	Junta de tipo O
31	835091M91	4 9/16	4	Union	Union	Unión
32		Ref. 31	1	Union	Union	Unión
33	831452M1	31	1	O-Ring	Joint torique	Junta de tipo O
34	6110932M91	4 Slew	1	Hose Assy	Ensemble de flexible	Flexible, Conj.
35	6110930M91	4 Boom	1	Hose Assy	Ensemble de flexible	Flexible, Conj.
36	6110929M91	4 Dipper	1	Hose Assy	Ensemble de flexible	Flexible, Conj.
37	6110931M91	4 Bucket	1	Hose Assy	Ensemble de flexible	Flexible, Conj.
38	356266X1	4 Bulkhead	4	Union	Union	Unión
39	355830X1	4	4	Nut	Écrou	Tuerca
40	835091M91	4 9/16	1	Union	Union	Unión
41		Ref. 40	1	Union	Union	Unión
42	831452M1	40	1	O-Ring	Joint torique	Junta de tipo O
43	6110815M91	4	1	Valve, Pressure	Soupape de pression	Válvula de presión
44	390246X1	4 M8 x 70	2	Bolt	Boulon	Perno



820 880 980
 TX760B TX860B
 TX870B TX970B

801 802 803 804 831 832 841 842 843 844 851 852 853 854 932

38007C01.1

6199042M3

1

Jan-06

Hydraulic Valve
Distributeur de Commande Hydraulique
Distribuidor de mando hidráulico

Backhoe Control
Godet Rétro
Equipo retro

Centre mounted digger installation
 Installation montage de pelle central
 La Instalación excavadora de montaje central

Servo
 Servo
 Servo

C-38007-01.1-A

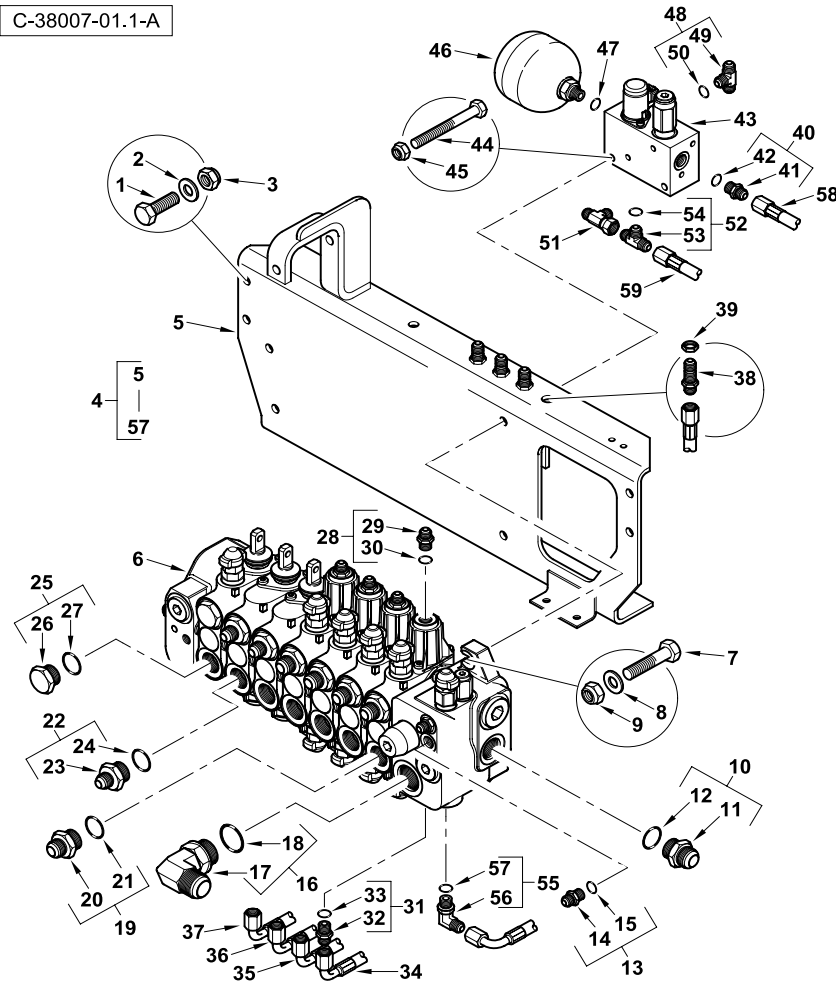

45	339009X1	4	M8 x 35	2	Screw	Vis	Tornillo
46	6110914M91	4		1	Accumulator	Accumulateur	Acumulador
47	831452M1	4		1	O-Ring	Joint torique	Junta de tipo O
48	358828X91	4		2	Union	Union	Unión
49		48	Ref. 48	1	Tee	Raccord en T	Te
50	831452M1	48		1	O-Ring	Joint torique	Junta de tipo O
51	370576X1	4		2	Tee	Raccord en T	Te
52	358828X91	4		1	Union	Union	Unión
53		52	Ref. 52	1	Tee	Raccord en T	Te
54	831452M1	52		1	O-Ring	Joint torique	Junta de tipo O
55	357197X91	4		1	Elbow, 90°	Coude à 90°	Codo, 90°
56		55	Ref. 55	1	Elbow	Coude	Codo
57	831452M1	55		1	O-Ring	Joint torique	Junta de tipo O
58	6110912M91			1	Hose Assy	Ensemble de flexible	Flexible, Conj.
59	6110911M91			1	Hose Assy	Ensemble de flexible	Flexible, Conj.

A Without Auxiliary Hydraulics
 Sans Hydraulique Auxiliaire
 Sin hidraulico auxiliar



820 880 980
 TX760B TX860B
 TX870B TX970B

801 802 803 804 831 832 841 842 843 844 851 852 853 854 932

38007C01.1

6199042M3

1

Jan-06

Hydraulic Valve
Distributeur de Commande Hydraulique
Distribuidor de mando hidráulico

Backhoe Control
Godet Rétro
Equipo retro

Centre mounted digger installation
 Installation montage de pelle central
 La Instalación excavadora de montaje central

Servo
 Servo
 Servo

C-38007-02.1-A

1	6110917M91		1	Valve Assy, Control	Ensemble distribution	Distribuidor, Conj.
2	6194534M91		1	Element - Inlet		
3	6193771M91	Interface	1	Kit, Seal	Pochette de joints	Juego de juntas
4	6193789M91	Inlet element	1	Kit, Seal	Pochette de joints	Juego de juntas

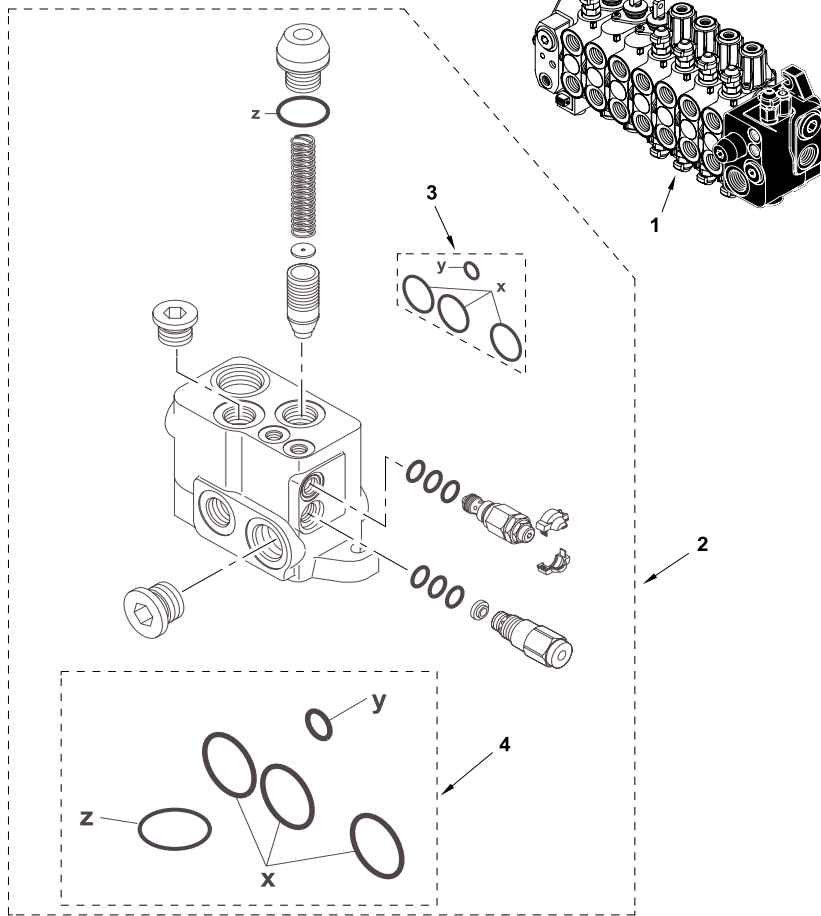

820 880 980
 TX760B TX860B
 TX870B TX970B

801 802 803 804 831 832 841 842 843 844 851 852 853 854 932

38007C02.1

6199042M3

1

Jan-06

Hydraulic Valve
Distributeur de Commande Hydraulique
Distribuidor de mando hidráulico

Backhoe Control
Godet Rétro
Equipo retro

Centre mounted digger installation
 Installation montage de pelle central
 La Instalación excavadora de montaje central

Servo
 Servo
 Servo

C-38007-03.1-A

1	6110917M91			1	Valve Assy, Control	Ensemble distribution	Distribuidor, Conj.
2	6194525M91			1	Element - Slew		
3	6193800M91			1	240 Bar PRV		
4	6193771M91	Interface		1	Kit, Seal	Pochette de joints	Juego de juntas
5	6193800M91			1	240 Bar PRV		
6	6194518M91			1	Kit, Seal	Pochette de joints	Juego de juntas

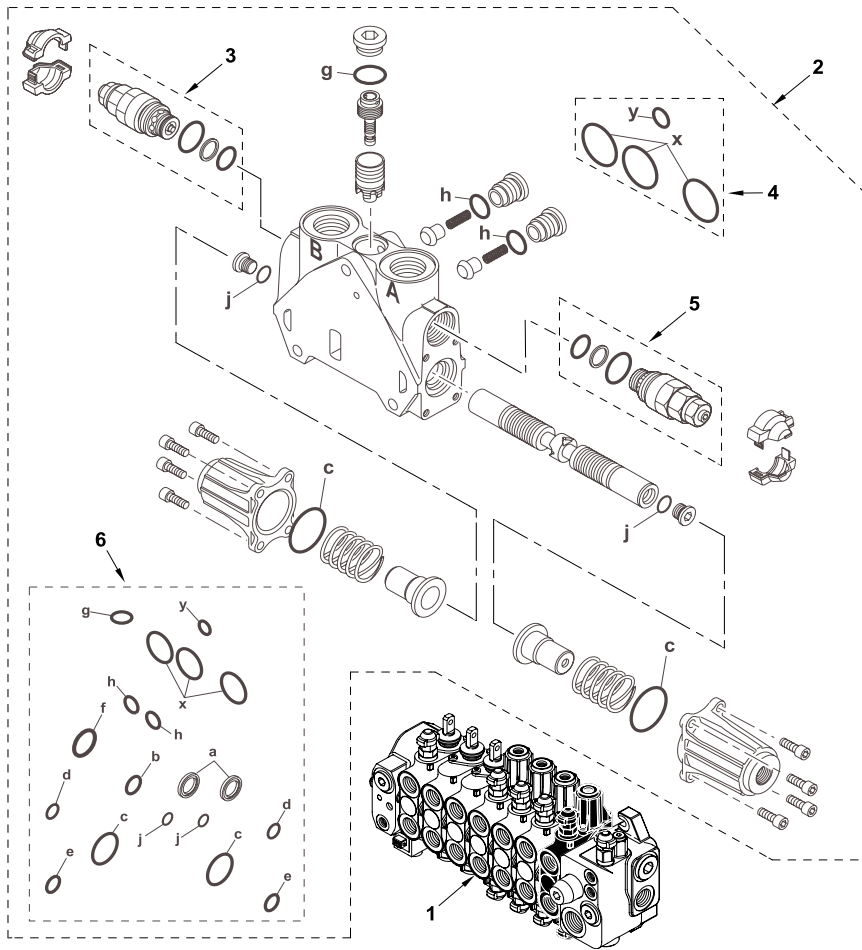

820 880 980
 TX760B TX860B
 TX870B TX970B

801 802 803 804 831 832 841 842 843 844 851 852 853 854 932

38007C03.1

6199042M3

1

Jan-06

Hydraulic Valve
Distributeur de Commande Hydraulique
Distribuidor de mando hidráulico

Backhoe Control
Godet Rétro
Equipo retro

Centre mounted digger installation
 Installation montage de pelle central
 La Instalación excavadora de montaje central

Servo
 Servo
 Servo

C-38007-04.1-A

1	6110917M91			1	Valve Assy, Control	Ensemble distribution	Distribuidor, Conj.
2	6194526M91			1	Element - Boom		
3	6193804M91			1	310 Bar PRV		
4	6193771M91	Interface		1	Kit, Seal	Pochette de joints	Juego de juntas
5	6193800M91			1	240 Bar PRV		
6	6193781M91			1	Kit, Seal	Pochette de joints	Juego de juntas

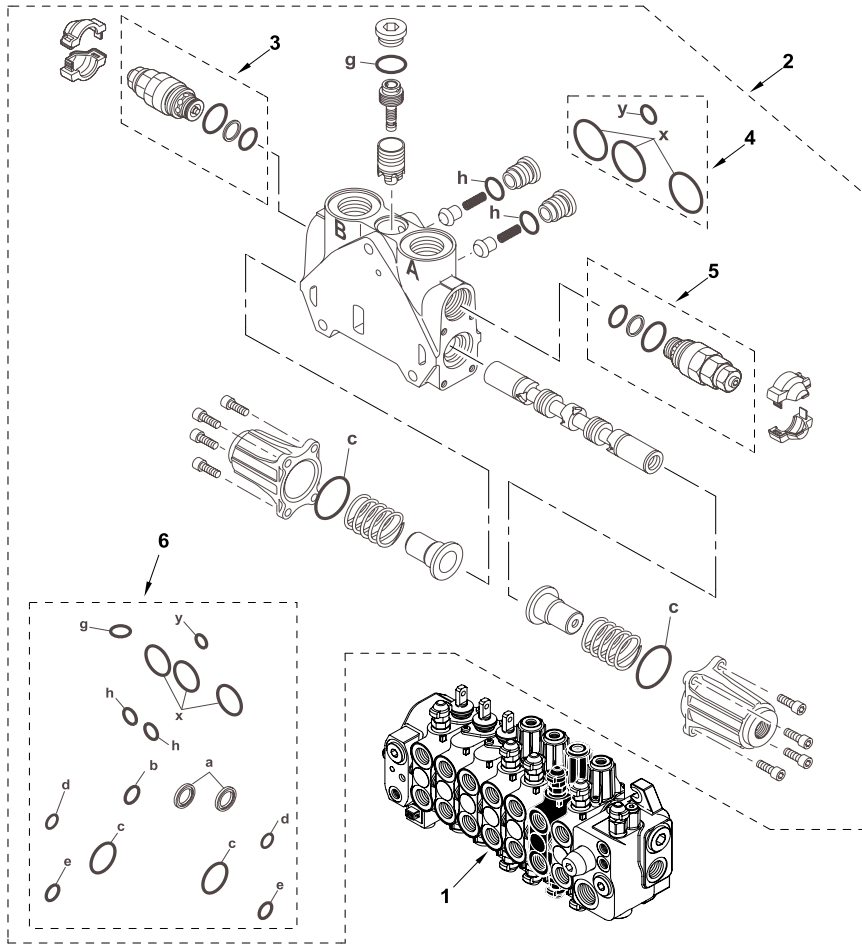

820 880 980
 TX760B TX860B
 TX870B TX970B

801 802 803 804 831 832 841 842 843 844 851 852 853 854 932

38007C04.1

6199042M3

1

Jan-06

Hydraulic Valve
Distributeur de Commande Hydraulique
Distribuidor de mando hidráulico

Backhoe Control
Godet Rétro
Equipo retro

Centre mounted digger installation
 Installation montage de pelle central
 La Instalación excavadora de montaje central

Servo
 Servo
 Servo

C-38007-05.1-A

1	6110917M91			1	Valve Assy, Control	Ensemble distribution	Distribuidor, Conj.
2	6194527M91			1	Element - Dipper		
3	6193802M91			1	265 Bar PRV		
4	6193771M91	Interface		1	Kit, Seal	Pochette de joints	Juego de juntas
5	6193808M91			1	280 Bar PRV		
6	6193781M91			1	Kit, Seal	Pochette de joints	Juego de juntas

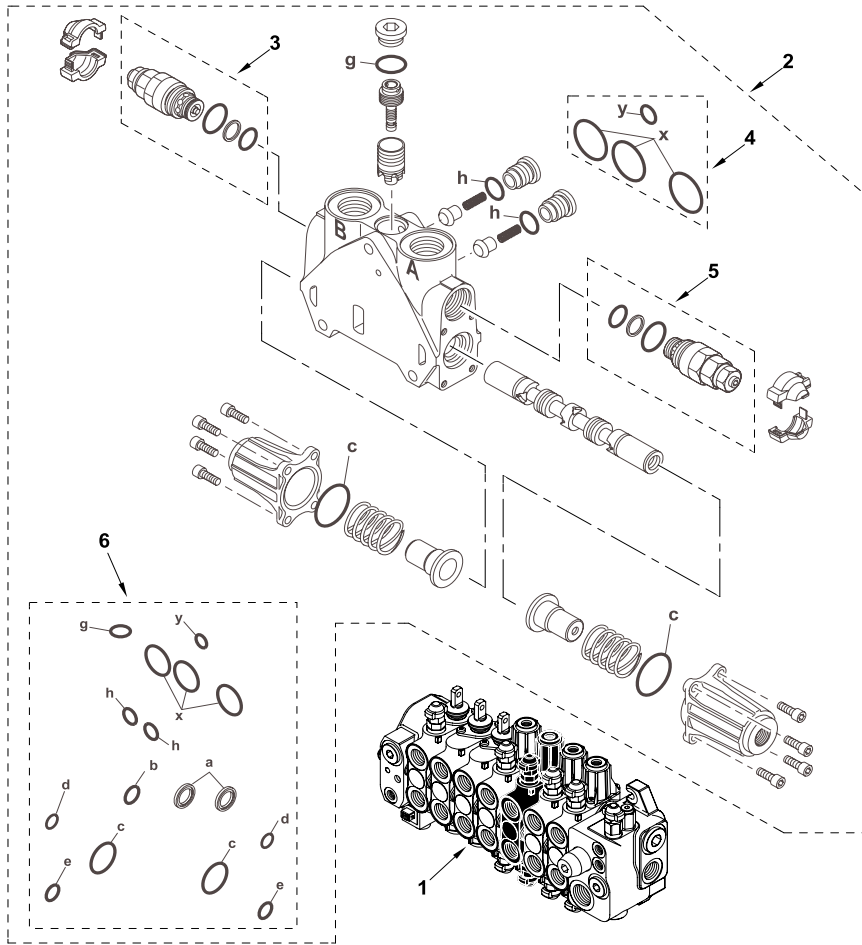

820 880 980
 TX760B TX860B
 TX870B TX970B

801 802 803 804 831 832 841 842 843 844 851 852 853 854 932

38007C05.1

6199042M3

1

Jan-06

Hydraulic Valve
Distributeur de Commande Hydraulique
Distribuidor de mando hidráulico

Backhoe Control
Godet Rétro
Equipo retro

Centre mounted digger installation
 Installation montage de pelle central
 La Instalación excavadora de montaje central

Servo
 Servo
 Servo

C-38007-06.1-A

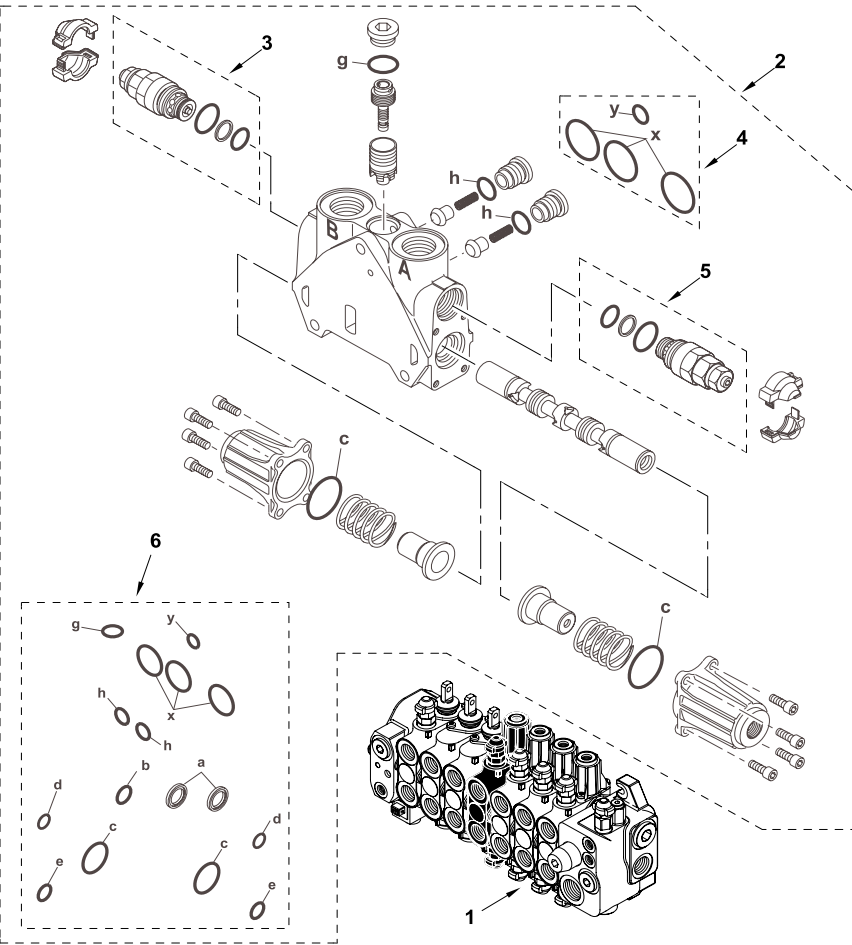

1	6110917M91			1	Valve Assy, Control	Ensemble distribution	Distribuidor, Conj.
2	6194531M91			1	Element - Bucket		
3	6193805M91			1	280 Bar PRV		
4	6193771M91	Interface		1	Kit, Seal	Pochette de joints	Juego de juntas
5	6193805M91			1	280 Bar PRV		
6	6193781M91			1	Kit, Seal	Pochette de joints	Juego de juntas



820 880 980
 TX760B TX860B
 TX870B TX970B

801 802 803 804 831 832 841 842 843 844 851 852 853 854 932

38007C06.1

6199042M3

1

Jan-06

Hydraulic Valve
Distributeur de Commande Hydraulique
Distribuidor de mando hidráulico

Backhoe Control
Godet Rétro
Equipo retro

Centre mounted digger installation
 Installation montage de pelle central
 La Instalación excavadora de montaje central

Servo
 Servo
 Servo

C-38007-07.1-A

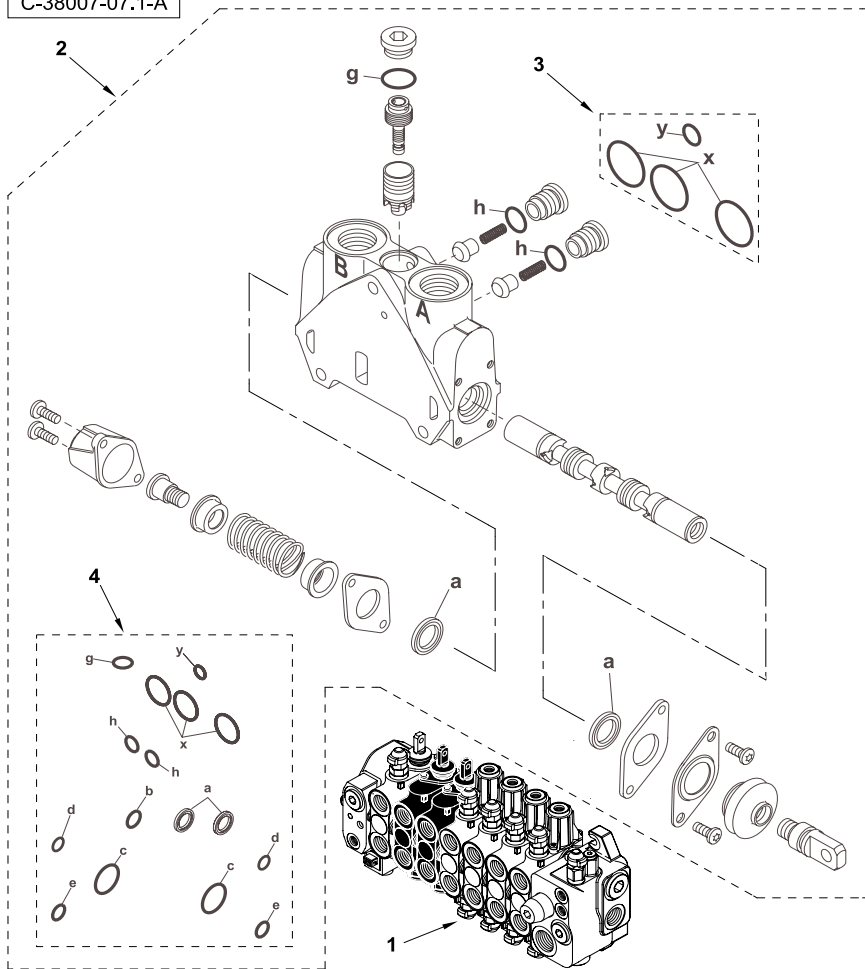

1	6110917M91		1	Valve Assy, Control	Ensemble distribution	Distribuidor, Conj.
2	6194523M91		1	Element - Stabiliser		
3	6193771M91	Interface	1	Kit, Seal	Pochette de joints	Juego de juntas
4	6193781M91		1	Kit, Seal	Pochette de joints	Juego de juntas



820 880 980
 TX760B TX860B
 TX870B TX970B

801 802 803 804 831 832 841 842 843 844 851 852 853 854 932

38007C07.1

6199042M3

1

Jan-06

Hydraulic Valve
Distributeur de Commande Hydraulique
Distribuidor de mando hidráulico

Backhoe Control
Godet Rétro
Equipo retro

Centre mounted digger installation
 Installation montage de pelle central
 La Instalación excavadora de montaje central

Servo
 Servo
 Servo

C-38007-08.1-A

1	6110917M91		1	Valve Assy, Control	Ensemble distribution	Distribuidor, Conj.
2	6194524M91		1	Element - Telescope		
3	6193785M91		1	Plug Assy	Ensemble bouchons	Tapón, Conj.
4	6193771M91	Interface	1	Kit, Seal	Pochette de joints	Juego de juntas
5	6193799M91		1	155 Bar PRV		
6	6193781M91		1	Kit, Seal	Pochette de joints	Juego de juntas

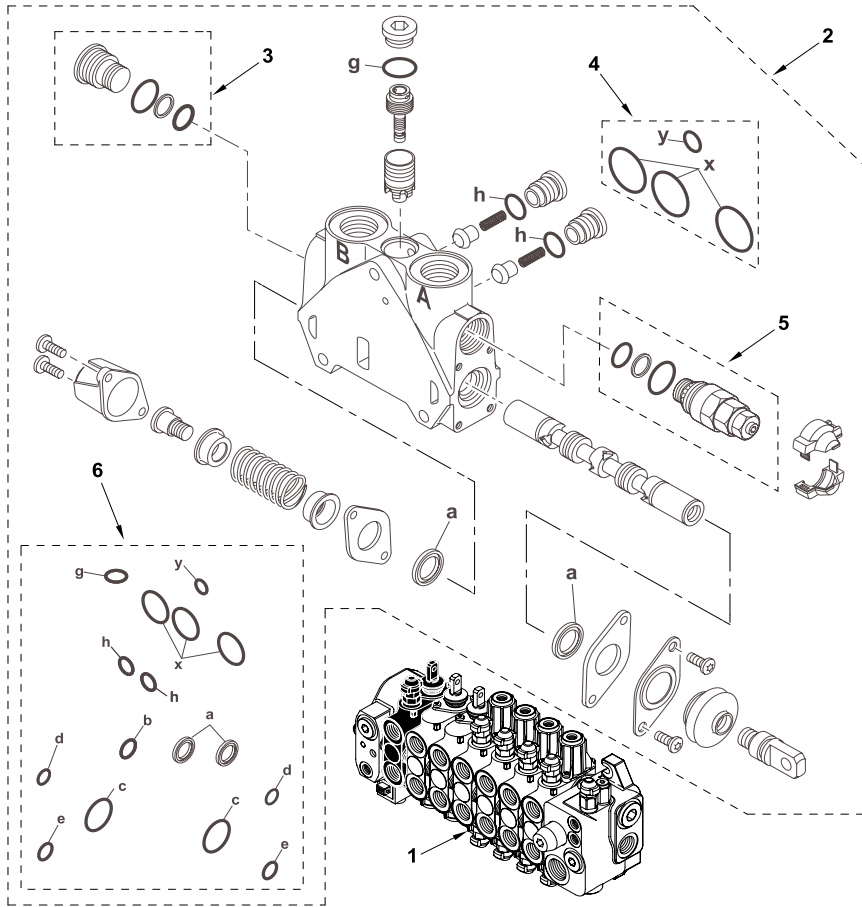

820 880 980
 TX760B TX860B
 TX870B TX970B

801 802 803 804 831 832 841 842 843 844 851 852 853 854 932

38007C08.1

6199042M3

1

Jan-06

Hydraulic Valve
Distributeur de Commande Hydraulique
Distribuidor de mando hidráulico

Backhoe Control
Godet Rétro
Equipo retro

Centre mounted digger installation
 Installation montage de pelle central
 La Instalación excavadora de montaje central

Servo
 Servo
 Servo

C-38007-09.1-A

1	6110917M91		1	Valve Assy, Control	Ensemble distribution	Distribuidor, Conj.
2	6194516M91		1	Element - Outlet		
3	6193771M91	Interface	1	Kit, Seal	Pochette de joints	Juego de juntas

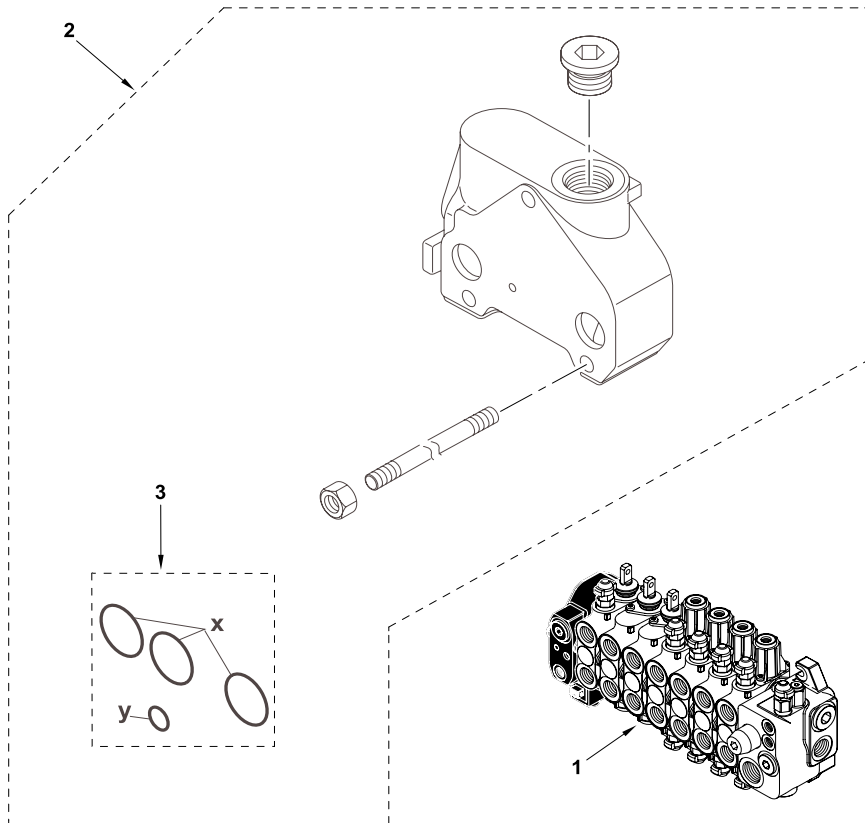

820 880 980
 TX760B TX860B
 TX870B TX970B

801 802 803 804 831 832 841 842 843 844 851 852 853 854 932

38007C09.1

6199042M3

1

Jan-06

Hydraulic Valve
Distributeur de Commande Hydraulique
Distribuidor de mando hidráulico

Backhoe Control
Godet Rétro
Equipo retro

Centre mounted digger installation
 Installation montage de pelle central
 La Instalación excavadora de montaje central

Servo
 Servo
 Servo

C-38008-01.1-A

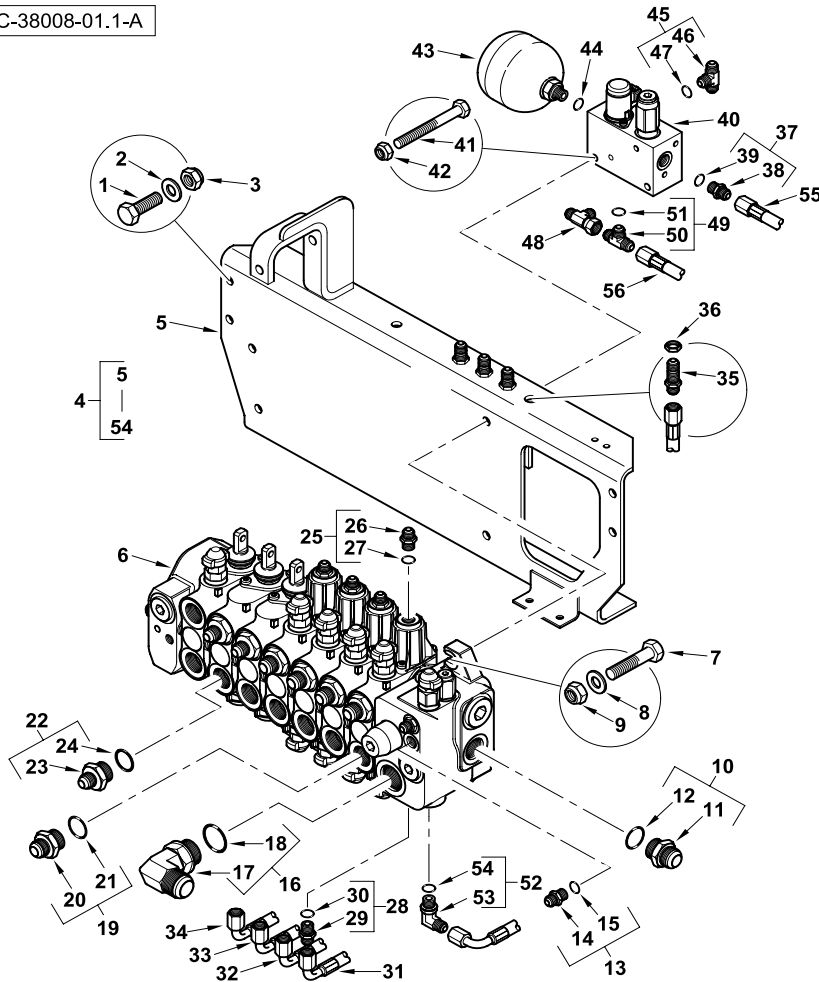

1	3009493X1	M10 x 30	4	Bolt	Boulon	Perno
2	385362X1	M10	4	Washer	Rondelle	Arandela
3	1440329X1	M10	4	Nut, Lock	Écrou de blocage	Tuerca de retención
4	6110923M91	(A)	1	Valve Assy, Control	Ensemble distribution	Distribuidor, Conj.
5	6110773M91	4	1	Bracket Assy	Ensemble chaise palier	Cuchara, Conj.
6	6110917M91	4	1	Valve Assy, Control	Ensemble distribution	Distribuidor, Conj.
7	3009496X1	4 M10 x 45	3	Screw	Vis	Tornillo
8	385362X1	4 M10	3	Washer	Rondelle	Arandela
9	1440329X1	4 M10	3	Nut, Lock	Écrou de blocage	Tuerca de retención
10	835057M91	4	1	Connector Assy	Ensemble connexion	Conexión, Conj.
11	10	➡ Ref. 10	1	Union	Union	Unión
12	835025M1	10	1	O-Ring	Joint torique	Junta de tipo O
13	835091M91	4 9/16	2	Union	Union	Unión
14	13	➡ Ref. 13	1	Union	Union	Unión
15	831452M1	13	1	O-Ring	Joint torique	Junta de tipo O
16	358766X91	4	1	Elbow, 90°	Coude à 90°	Codo, 90°
17	16	➡ Ref. 16	1	Elbow	Coude	Codo
18	835026M1	16	1	O-Ring	Joint torique	Junta de tipo O
19	365715X91	4 1,1/16" - 7/8" UNF	8	Connector Assy	Ensemble connexion	Conexión, Conj.
20	19	➡ Ref. 19	1	Union	Union	Unión
21	835025M1	19	1	O-Ring	Joint torique	Junta de tipo O
22	365713X91	4	4	Union	Union	Unión
23	22	➡ Ref. 22	1	Union	Union	Unión
24	835025M1	22	1	O-Ring	Joint torique	Junta de tipo O
25	835091M91	4 9/16	4	Union	Union	Unión
26	25	➡ Ref. 25	1	Union	Union	Unión
27	831452M1	25	1	O-Ring	Joint torique	Junta de tipo O
28	835091M91	4 9/16	4	Union	Union	Unión
29	28	➡ Ref. 28	1	Union	Union	Unión
30	831452M1	28	1	O-Ring	Joint torique	Junta de tipo O
31	6110932M91	4 Slew	1	Hose Assy	Ensemble de flexible	Flexible, Conj.
32	6110930M91	4 Boom	1	Hose Assy	Ensemble de flexible	Flexible, Conj.
33	6110929M91	4 Dipper	1	Hose Assy	Ensemble de flexible	Flexible, Conj.
34	6110931M91	4 Bucket	1	Hose Assy	Ensemble de flexible	Flexible, Conj.
35	356266X1	4 Bulkhead	4	Union	Union	Unión
36	355830X1	4	4	Nut	Écrou	Tuerca
37	835091M91	4 9/16	1	Union	Union	Unión
38	37	➡ Ref. 37	1	Union	Union	Unión
39	831452M1	37	1	O-Ring	Joint torique	Junta de tipo O
40	6110815M91	4	1	Valve, Pressure	Soupape de pression	Válvula de presión
41	390246X1	4 M8 x 70	2	Bolt	Boulon	Perno
42	339009X1	4 M8 x 35	2	Screw	Vis	Tornillo
43	6110914M91	4	1	Accumulator	Accumulateur	Acumulador
44	831452M1	4	1	O-Ring	Joint torique	Junta de tipo O



820 880 970 980
 TX760B TX860B
 TX870B TX970B

801 802 803 804 831 832 841 842 843 844 851 852 853 854 923 932

38008C01.1

6199042M3

1

Jan-06

Hydraulic Valve
Distributeur de Commande Hydraulique
Distribuidor de mando hidráulico

Backhoe Control
Godet Rétro
Equipo retro

Centre mounted digger installation
 Installation montage de pelle central
 La Instalación excavadora de montaje central

Servo
 Servo
 Servo

C-38008-01.1-A

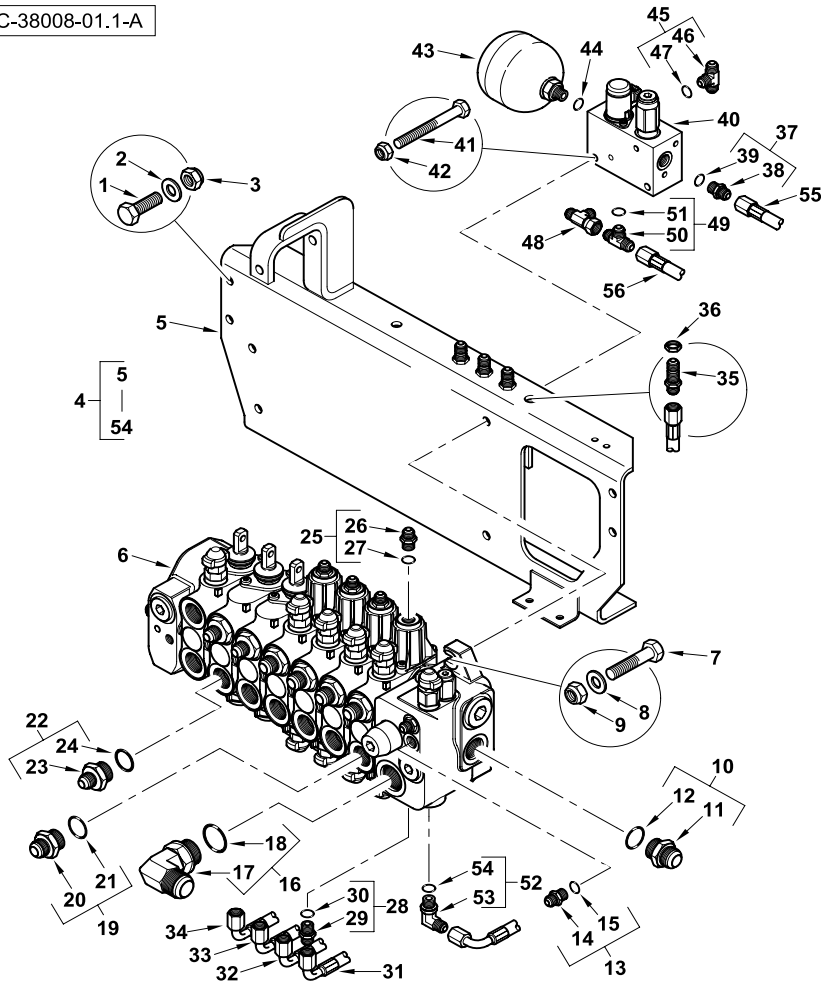

45	358828X91	4		2	Union	Union	Unión
46		45	▶ Ref. 45	1	Tee	Raccord en T	Te
47	831452M1	45		1	O-Ring	Joint torique	Junta de tipo O
48	370576X1	4		2	Tee	Raccord en T	Te
49	358828X91	4		1	Union	Union	Unión
50		49	▶ Ref. 49	1	Tee	Raccord en T	Te
51	831452M1	49		1	O-Ring	Joint torique	Junta de tipo O
52	357197X91	4		1	Elbow, 90°	Coude à 90°	Codo, 90°
53		52	▶ Ref. 52	1	Elbow	Coude	Codo
54	831452M1	52		1	O-Ring	Joint torique	Junta de tipo O
55	6110912M91			1	Hose Assy	Ensemble de flexible	Flexible, Conj.
56	6110911M91			1	Hose Assy	Ensemble de flexible	Flexible, Conj.

A With Auxiliary Hydraulics
 Avec Hydraulique Auxiliaire
 Con hidraulico auxiliar



820 880 970 980
 TX760B TX860B
 TX870B TX970B

801 802 803 804 831 832 841 842 843 844 851 852 853 854 923 932

38008C01.1

6199042M3

1

Jan-06

Hydraulic Valve
Distributeur de Commande Hydraulique
Distribuidor de mando hidráulico

Backhoe Control
Godet Rétro
Equipo retro

Centre mounted digger installation
 Installation montage de pelle central
 La Instalación excavadora de montaje central

Servo
 Servo
 Servo

C-38008-02.1-A

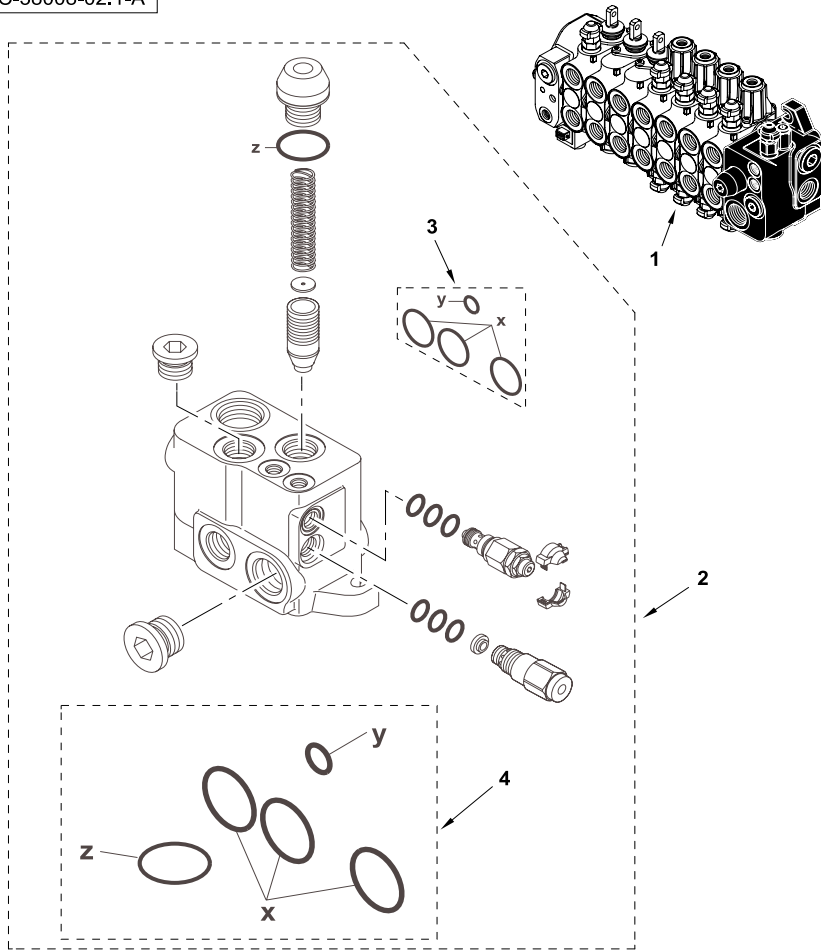

1	6110917M91		1	Valve Assy, Control	Ensemble distribution	Distribuidor, Conj.
2	6194534M91		1	Element - Inlet		
3	6193771M91	Interface	1	Kit, Seal	Pochette de joints	Juego de juntas
4	6193789M91	Inlet element	1	Kit, Seal	Pochette de joints	Juego de juntas



820 880 970 980
 TX760B TX860B
 TX870B TX970B

801 802 803 804 831 832 841 842 843 844 851 852 853 854 923 932

38008C02.1

6199042M3

1

Jan-06

Hydraulic Valve
Distributeur de Commande Hydraulique
Distribuidor de mando hidráulico

Backhoe Control
Godet Rétro
Equipo retro

Centre mounted digger installation
 Installation montage de pelle central
 La Instalación excavadora de montaje central

Servo
 Servo
 Servo

C-38008-03.1-A

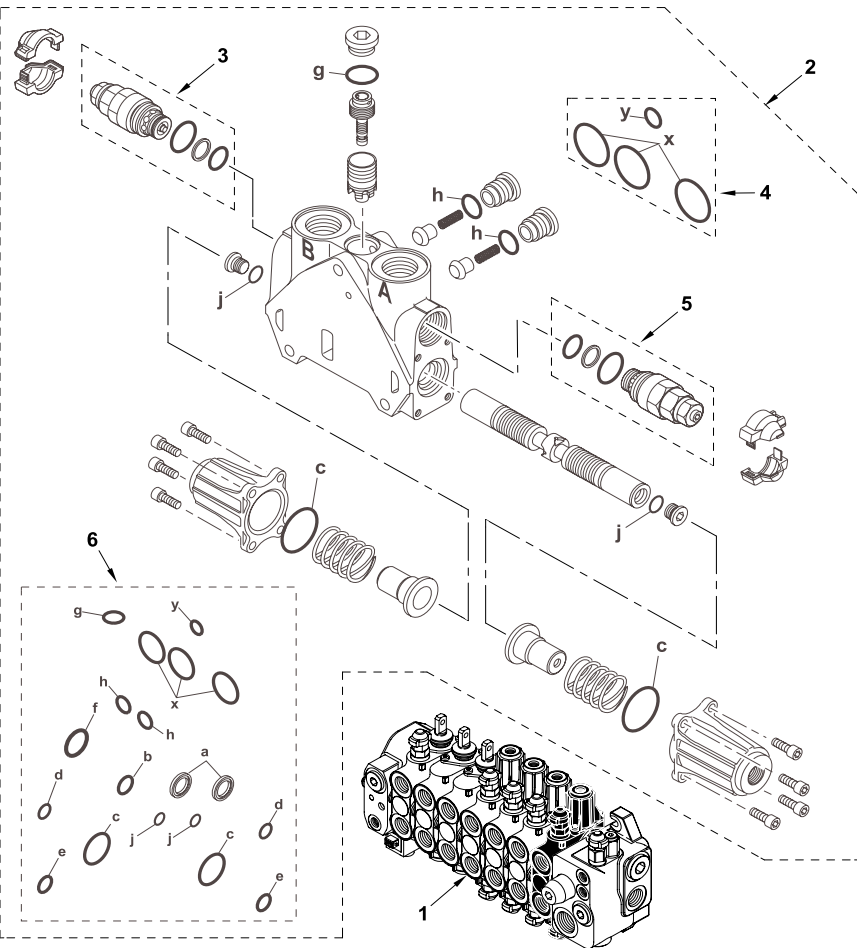

1	6110917M91			1	Valve Assy, Control	Ensemble distribution	Distribuidor, Conj.
2	6194525M91			1	Element - Slew		
3	6193800M91			1	240 Bar PRV		
4	6193771M91	Interface		1	Kit, Seal	Pochette de joints	Juego de juntas
5	6193800M91			1	240 Bar PRV		
6	6194518M91			1	Kit, Seal	Pochette de joints	Juego de juntas



820 880 970 980
 TX760B TX860B
 TX870B TX970B

801 802 803 804 831 832 841 842 843 844 851 852 853 854 923 932

38008C03.1

6199042M3

1

Jan-06

Hydraulic Valve
Distributeur de Commande Hydraulique
Distribuidor de mando hidráulico

Backhoe Control
Godet Rétro
Equipo retro

Centre mounted digger installation
 Installation montage de pelle central
 La Instalación excavadora de montaje central

Servo
 Servo
 Servo

C-38008-04.1-A

1	6110917M91			1	Valve Assy, Control	Ensemble distribution	Distribuidor, Conj.
2	6194526M91			1	Element - Boom		
3	6193804M91			1	310 Bar PRV		
4	6193771M91	Interface		1	Kit, Seal	Pochette de joints	Juego de juntas
5	6193800M91			1	240 Bar PRV		
6	6193781M91			1	Kit, Seal	Pochette de joints	Juego de juntas

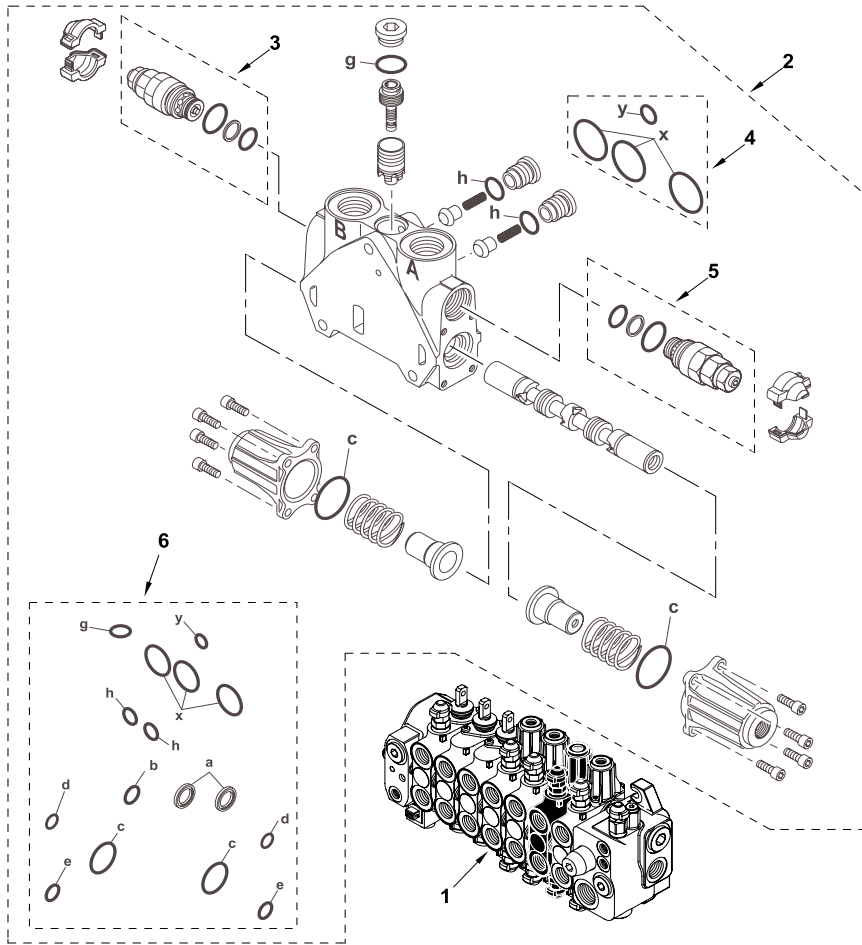

820 880 970 980
 TX760B TX860B
 TX870B TX970B

801 802 803 804 831 832 841 842 843 844 851 852 853 854 923 932

38008C04.1

6199042M3

1

Jan-06

Hydraulic Valve
Distributeur de Commande Hydraulique
Distribuidor de mando hidráulico

Backhoe Control
Godet Rétro
Equipo retro

Centre mounted digger installation
 Installation montage de pelle central
 La Instalación excavadora de montaje central

Servo
 Servo
 Servo

C-38008-05.1-A

1	6110917M91			1	Valve Assy, Control	Ensemble distribution	Distribuidor, Conj.
2	6194527M91			1	Element - Dipper		
3	6193802M91			1	265 Bar PRV		
4	6193771M91	Interface		1	Kit, Seal	Pochette de joints	Juego de juntas
5	6193808M91			1	280 Bar PRV		
6	6193781M91			1	Kit, Seal	Pochette de joints	Juego de juntas

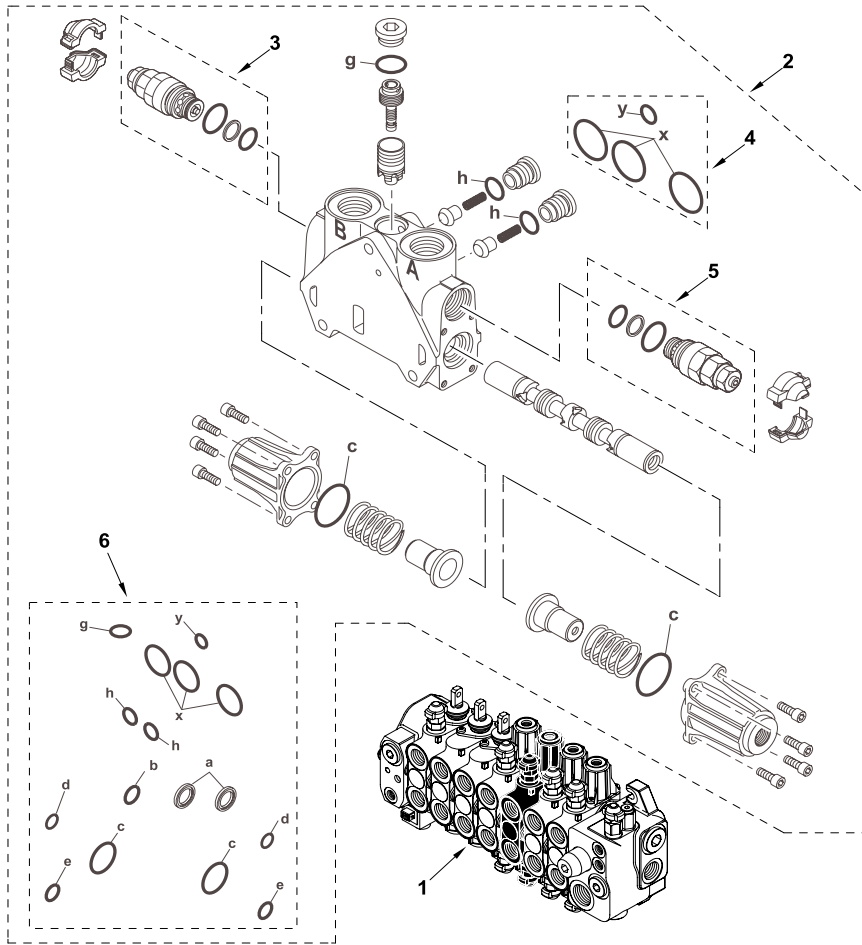

820 880 970 980
 TX760B TX860B
 TX870B TX970B

801 802 803 804 831 832 841 842 843 844 851 852 853 854 923 932

38008C05.1

6199042M3

1

Jan-06

Hydraulic Valve
Distributeur de Commande Hydraulique
Distribuidor de mando hidráulico

Backhoe Control
Godet Rétro
Equipo retro

Centre mounted digger installation
 Installation montage de pelle central
 La Instalación excavadora de montaje central

Servo
 Servo
 Servo

C-38008-06.1-A

1	6110917M91		1	Valve Assy, Control	Ensemble distribution	Distribuidor, Conj.
2	6194531M91		1	Element - Bucket		
3	6193805M91		1	280 Bar PRV		
4	6193771M91	Interface	1	Kit, Seal	Pochette de joints	Juego de juntas
5	6193805M91		1	280 Bar PRV		
6	6193781M91		1	Kit, Seal	Pochette de joints	Juego de juntas

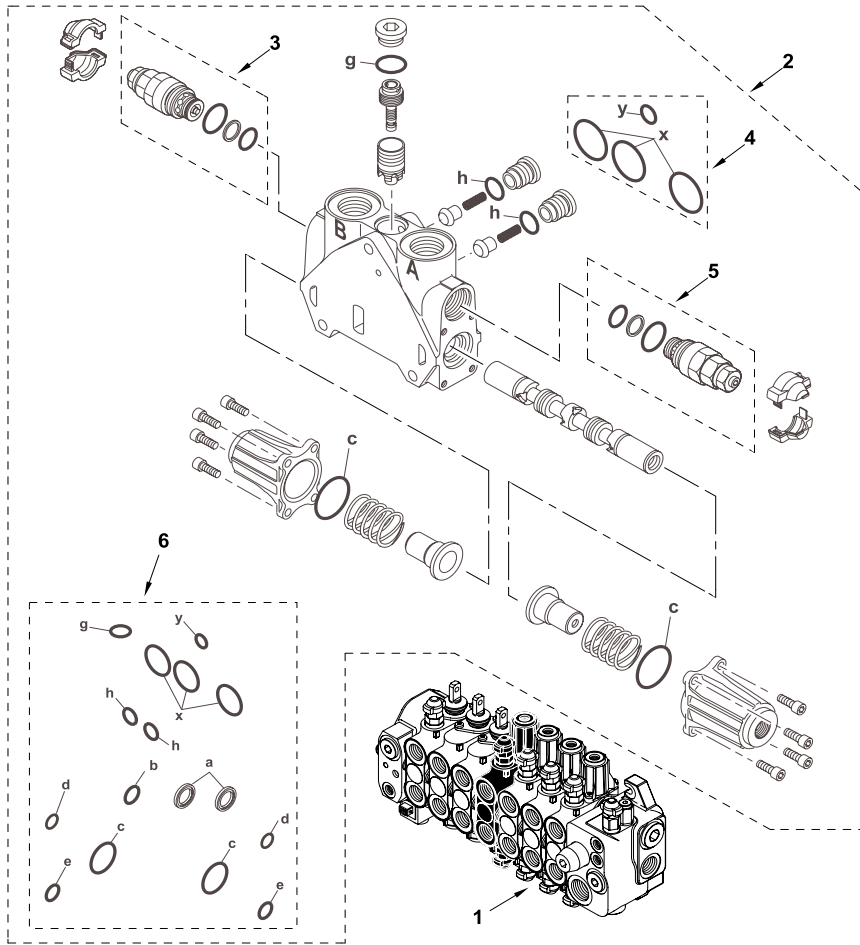

820 880 970 980
 TX760B TX860B
 TX870B TX970B

801 802 803 804 831 832 841 842 843 844 851 852 853 854 923 932

38008C06.1

6199042M3

1

Jan-06

Hydraulic Valve
Distributeur de Commande Hydraulique
Distribuidor de mando hidráulico

Backhoe Control
Godet Rétro
Equipo retro

Centre mounted digger installation
 Installation montage de pelle central
 La Instalación excavadora de montaje central

Servo
 Servo
 Servo

C-38008-07.1-A

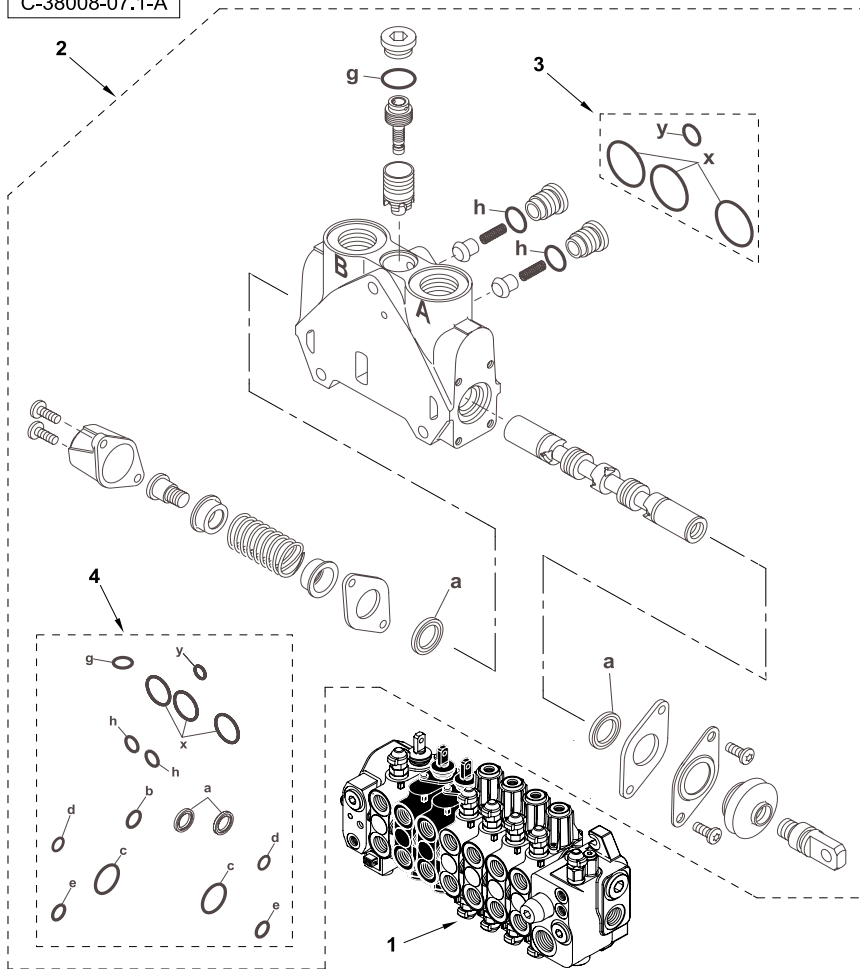

1	6110917M91			1	Valve Assy, Control	Ensemble distribution	Distribuidor, Conj.
2	6194523M91			1	Element - Stabiliser		
3	6193771M91	Interface		1	Kit, Seal	Pochette de joints	Juego de juntas
4	6193781M91			1	Kit, Seal	Pochette de joints	Juego de juntas



820 880 970 980
 TX760B TX860B
 TX870B TX970B

801 802 803 804 831 832 841 842 843 844 851 852 853 854 923 932

38008C07.1

6199042M3

1

Jan-06

Hydraulic Valve
Distributeur de Commande Hydraulique
Distribuidor de mando hidráulico

Backhoe Control
Godet Rétro
Equipo retro

Centre mounted digger installation
 Installation montage de pelle central
 La Instalación excavadora de montaje central

Servo
 Servo
 Servo

C-38008-08.1-A

1	6110917M91		1	Valve Assy, Control	Ensemble distribution	Distribuidor, Conj.
2	6194524M91		1	Element - Telescope		
3	6193785M91		1	Plug Assy	Ensemble bouchons	Tapón, Conj.
4	6193771M91	Interface	1	Kit, Seal	Pochette de joints	Juego de juntas
5	6193799M91		1	155 Bar PRV		
6	6193781M91		1	Kit, Seal	Pochette de joints	Juego de juntas

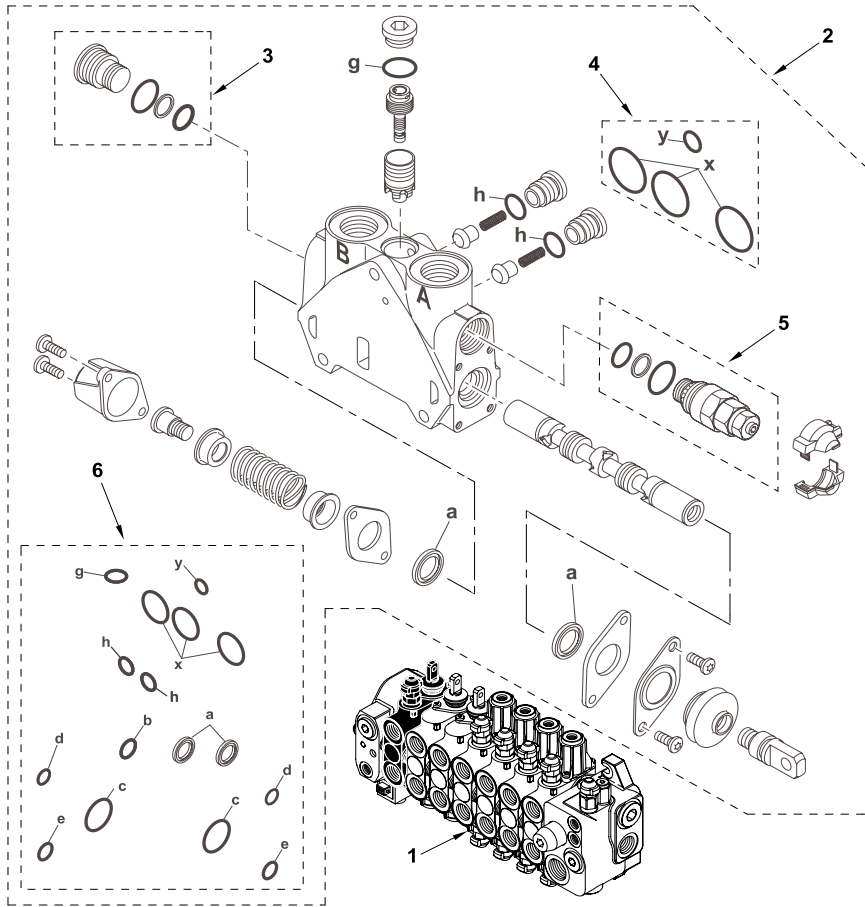

820 880 970 980
 TX760B TX860B
 TX870B TX970B

801 802 803 804 831 832 841 842 843 844 851 852 853 854 923 932

38008C08.1

6199042M3

1

Jan-06

Hydraulic Valve
Distributeur de Commande Hydraulique
Distribuidor de mando hidráulico

Backhoe Control
Godet Rétro
Equipo retro

Centre mounted digger installation
 Installation montage de pelle central
 La Instalación excavadora de montaje central

Servo
 Servo
 Servo

C-38008-09.1-A

1	6110917M91		1	Valve Assy, Control	Ensemble distribution	Distribuidor, Conj.
2	6194516M91		1	Element - Outlet		
3	6193771M91	Interface	1	Kit, Seal	Pochette de joints	Juego de juntas

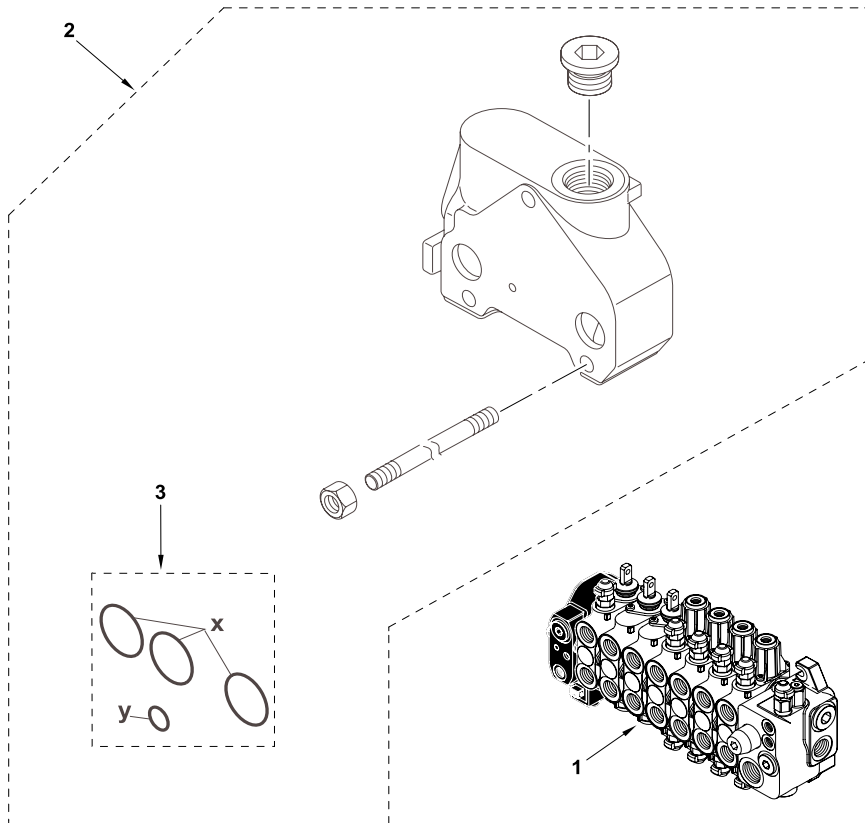

820 880 970 980
 TX760B TX860B
 TX870B TX970B

801 802 803 804 831 832 841 842 843 844 851 852 853 854 923 932

38008C09.1

6199042M3

1

Jan-06

Hydraulic Valve
Distributeur de Commande Hydraulique
Distribuidor de mando hidráulico

Backhoe Control
Godet Rétro
Equipo retro

Sideshift digger installation
 Installation montage de pelle latéral
 La Instalación excavadora de montaje horizontal

Servo
 Servo
 Servo

C-38009-01.1-A

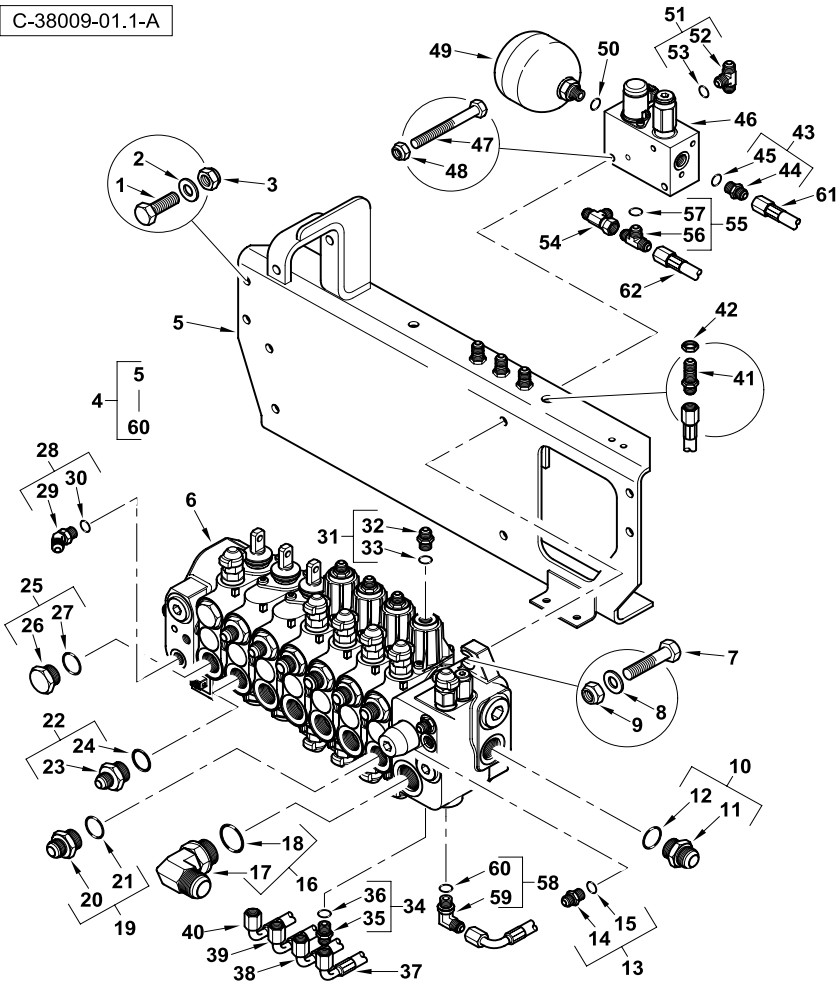

1	3009493X1	M10 x 30	4	Bolt	Boulon	Perno
2	385362X1	M10	4	Washer	Rondelle	Arandela
3	1440329X1	M10	4	Nut, Lock	Écrou de blocage	Tuerca de retención
4	6110924M91	(A)	1	Valve Assy, Control	Ensemble distribution	Distribuidor, Conj.
5	6110773M91	4	1	Bracket Assy	Ensemble chaise palier	Cuchara, Conj.
6	6110918M91	4	1	Valve Assy, Control	Ensemble distribution	Distribuidor, Conj.
7	3009496X1	4 M10 x 45	3	Screw	Vis	Tornillo
8	385362X1	4 M10	3	Washer	Rondelle	Arandela
9	1440329X1	4 M10	3	Nut, Lock	Écrou de blocage	Tuerca de retención
10	835057M91	4	1	Connector Assy	Ensemble connexion	Conexión, Conj.
11		Ref. 10	1	Union	Union	Unión
12	835025M1	10	1	O-Ring	Joint torique	Junta de tipo O
13	835091M91	4 9/16	2	Union	Union	Unión
14		Ref. 13	1	Union	Union	Unión
15	831452M1	13	1	O-Ring	Joint torique	Junta de tipo O
16	358766X91	4	1	Elbow, 90°	Coude à 90°	Codo, 90°
17		Ref. 16	1	Elbow	Coude	Codo
18	835026M1	16	1	O-Ring	Joint torique	Junta de tipo O
19	365715X91	4 1,1/16" - 7/8" UNF	8	Connector Assy	Ensemble connexion	Conexión, Conj.
20		Ref. 19	1	Union	Union	Unión
21	835025M1	19	1	O-Ring	Joint torique	Junta de tipo O
22	365713X91	4	4	Union	Union	Unión
23		Ref. 22	1	Union	Union	Unión
24	835025M1	22	1	O-Ring	Joint torique	Junta de tipo O
25	835099M91	4	2	Plug Assy	Ensemble bouchons	Tapón, Conj.
26		Ref. 25	1	Plug	Bouchon	Tapón
27	835025M1	25	1	O-Ring	Joint torique	Junta de tipo O
28	358781X91	4	1	Elbow, 45°	Coude à 45°	Codo, 45°
29		Ref. 28	1	Elbow	Coude	Codo
30	831452M1	25	1	O-Ring	Joint torique	Junta de tipo O
31	835091M91	4 9/16	4	Union	Union	Unión
32		Ref. 28	1	Union	Union	Unión
33	831452M1	28	1	O-Ring	Joint torique	Junta de tipo O
34	835091M91	4 9/16	4	Union	Union	Unión
35		Ref. 31	1	Union	Union	Unión
36	831452M1	31	1	O-Ring	Joint torique	Junta de tipo O
37	6110932M91	4 Slew	1	Hose Assy	Ensemble de flexible	Flexible, Conj.
38	6110930M91	4 Boom	1	Hose Assy	Ensemble de flexible	Flexible, Conj.
39	6110929M91	4 Dipper	1	Hose Assy	Ensemble de flexible	Flexible, Conj.
40	6110931M91	4 Bucket	1	Hose Assy	Ensemble de flexible	Flexible, Conj.
41	356266X1	4 Bulkhead	4	Union	Union	Unión
42	355830X1	4	4	Nut	Écrou	Tuerca
43	835091M91	4 9/16	1	Union	Union	Unión
44		Ref. 40	1	Union	Union	Unión



860 880 970 980
 TX860B

825 845 855 921 931

38009C01.1

6199042M3

1

Jan-06

Hydraulic Valve
Distributeur de Commande Hydraulique
Distribuidor de mando hidráulico

Backhoe Control
Godet Rétro
Equipo retro

Sideshift digger installation
 Installation montage de pelle latéral
 La Instalación excavadora de montaje horizontal

Servo
 Servo
 Servo

C-38009-01.1-A

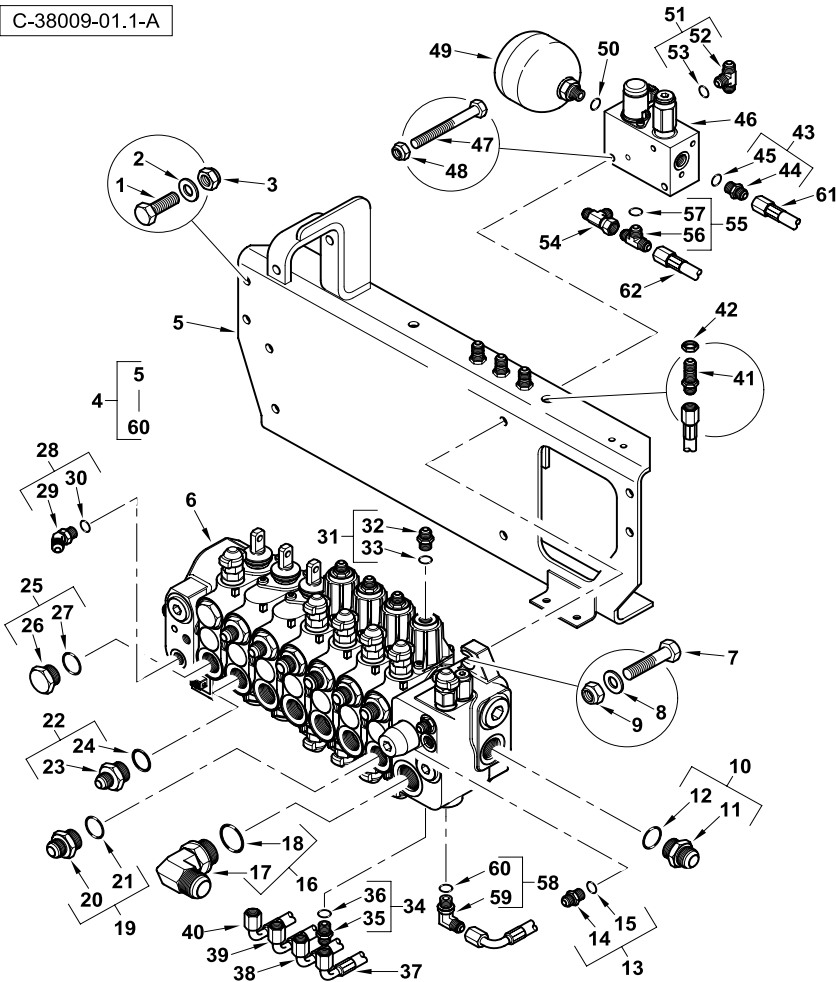

45	831452M1	40		1	O-Ring	Joint torique	Junta de tipo O
46	6110815M91	4		1	Valve, Pressure	Soupape de pression	Válvula de presión
47	390246X1	4	M8 x 70	2	Bolt	Boulon	Perno
48	339009X1	4	M8 x 35	2	Screw	Vis	Tornillo
49	6110914M91	4		1	Accumulator	Accumulateur	Acumulador
50	831452M1	4		1	O-Ring	Joint torique	Junta de tipo O
51	358828X91	4		1	Union	Union	Unión
52		48	Ref. 48	1	Tee	Raccord en T	Te
53	831452M1	48		1	O-Ring	Joint torique	Junta de tipo O
54	370576X1	4		1	Tee	Raccord en T	Te
55	358828X91	4		1	Union	Union	Unión
56		52	Ref. 52	1	Tee	Raccord en T	Te
57	831452M1	52		1	O-Ring	Joint torique	Junta de tipo O
58	357197X91	4		5	Elbow, 90°	Coude à 90°	Codo, 90°
59		55	Ref. 55	1	Elbow	Coude	Codo
60	831452M1	55		1	O-Ring	Joint torique	Junta de tipo O
61	6110912M91			1	Hose Assy	Ensemble de flexible	Flexible, Conj.
62	6110911M91			1	Hose Assy	Ensemble de flexible	Flexible, Conj.

A Without Auxiliary Hydraulics
 Sans Hydraulique Auxiliaire
 Sin hidraulico auxiliar



860 880 970 980
 TX860B

825 845 855 921 931

38009C01.1

6199042M3

1

Jan-06

Hydraulic Valve
Distributeur de Commande Hydraulique
Distribuidor de mando hidráulico

Backhoe Control
Godet Rétro
Equipo retro

Sideshift digger installation
 Installation montage de pelle latéral
 La Instalación excavadora de montaje horizontal

Servo
 Servo
 Servo

C-38009-02.1-A

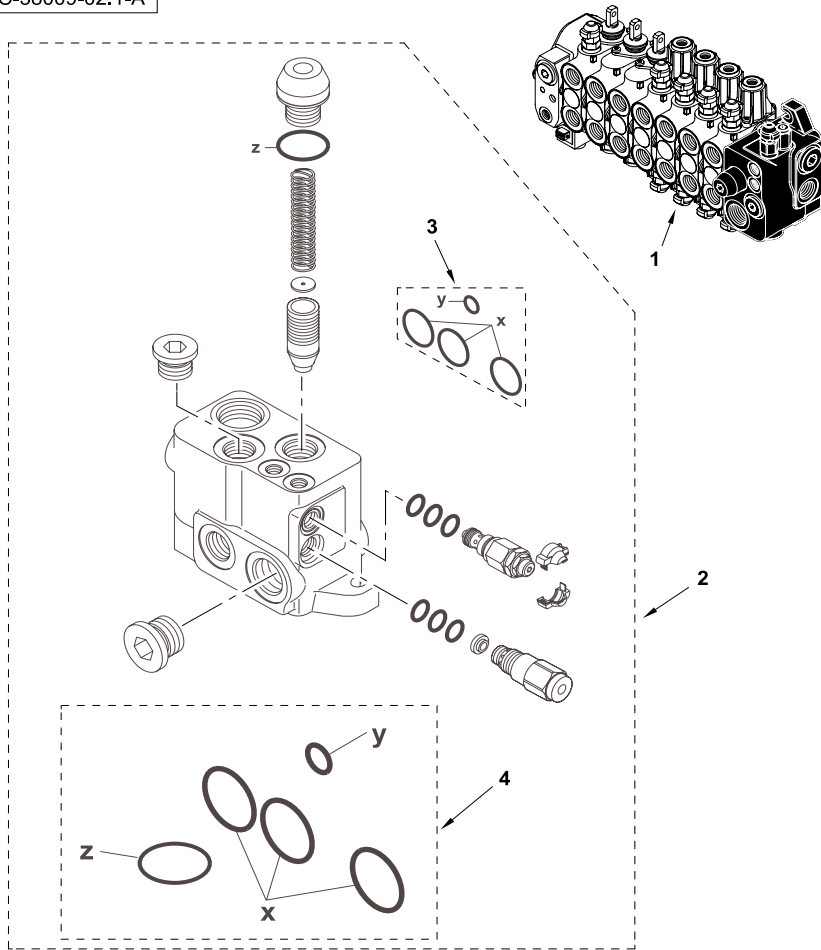

1	6110918M91		1	Valve Assy, Control	Ensemble distribution	Distribuidor, Conj.
2	6194534M91		1	Element - Inlet		
3	6193771M91	Interface	1	Kit, Seal	Pochette de joints	Juego de juntas
4	6193789M91	Inlet element	1	Kit, Seal	Pochette de joints	Juego de juntas



860 880 970 980
 TX860B

825 845 855 921 931

38009C02.1

6199042M3

1

Jan-06

Hydraulic Valve
Distributeur de Commande Hydraulique
Distribuidor de mando hidráulico

Backhoe Control
Godet Rétro
Equipo retro

Sideshift digger installation
 Installation montage de pelle latéral
 La Instalación excavadora de montaje horizontal

Servo
 Servo
 Servo

C-38009-03.1-A

1	6110918M91		1	Valve Assy, Control	Ensemble distribution	Distribuidor, Conj.
2	6194525M91		1	Element - Slew		
3	6193800M91		1	240 Bar PRV		
4	6193771M91	Interface	1	Kit, Seal	Pochette de joints	Juego de juntas
5	6193800M91		1	240 Bar PRV		
6	6193789M91	Inlet element	1	Kit, Seal	Pochette de joints	Juego de juntas

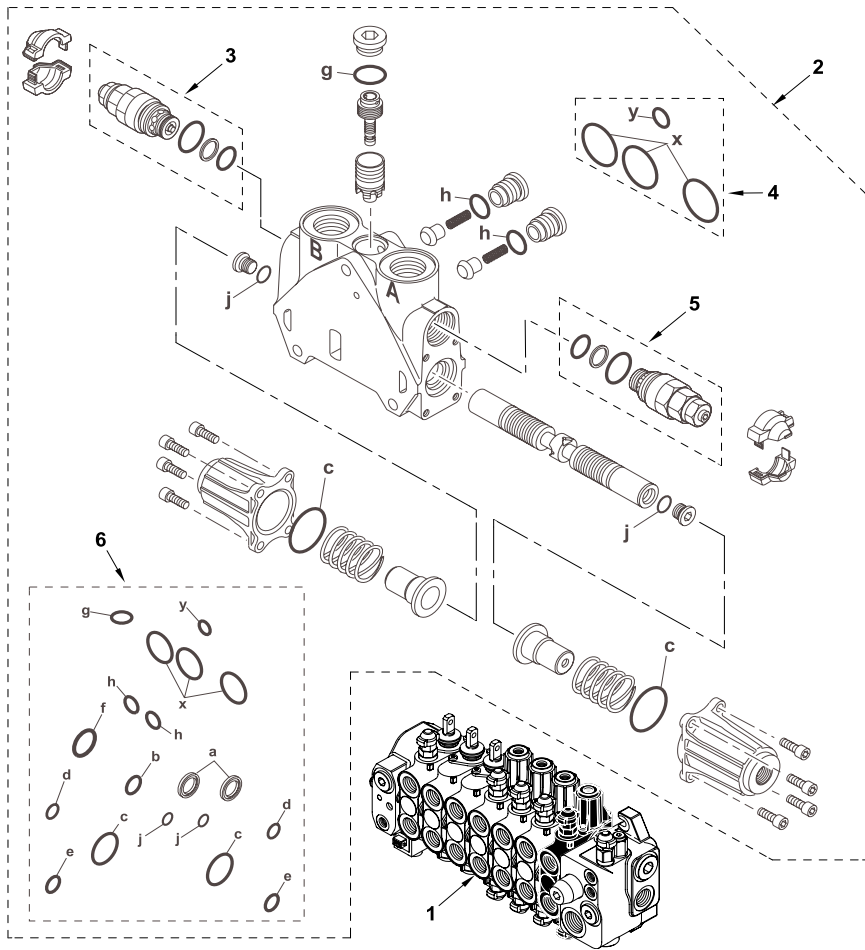

860 880 970 980
 TX860B

825 845 855 921 931

38009C03.1

6199042M3

1

Jan-06

Hydraulic Valve
Distributeur de Commande Hydraulique
Distribuidor de mando hidráulico

Backhoe Control
Godet Rétro
Equipo retro

Sideshift digger installation
 Installation montage de pelle latéral
 La Instalación excavadora de montaje horizontal

Servo
 Servo
 Servo

C-38009-04.1-A

1	6110918M91			1	Valve Assy, Control	Ensemble distribution	Distribuidor, Conj.
2	6194526M91			1	Element - Boom		
3	6193804M91			1	310 Bar PRV		
4	6193771M91	Interface		1	Kit, Seal	Pochette de joints	Juego de juntas
5	6193800M91			1	240 Bar PRV		
6	6193781M91			1	Kit, Seal	Pochette de joints	Juego de juntas

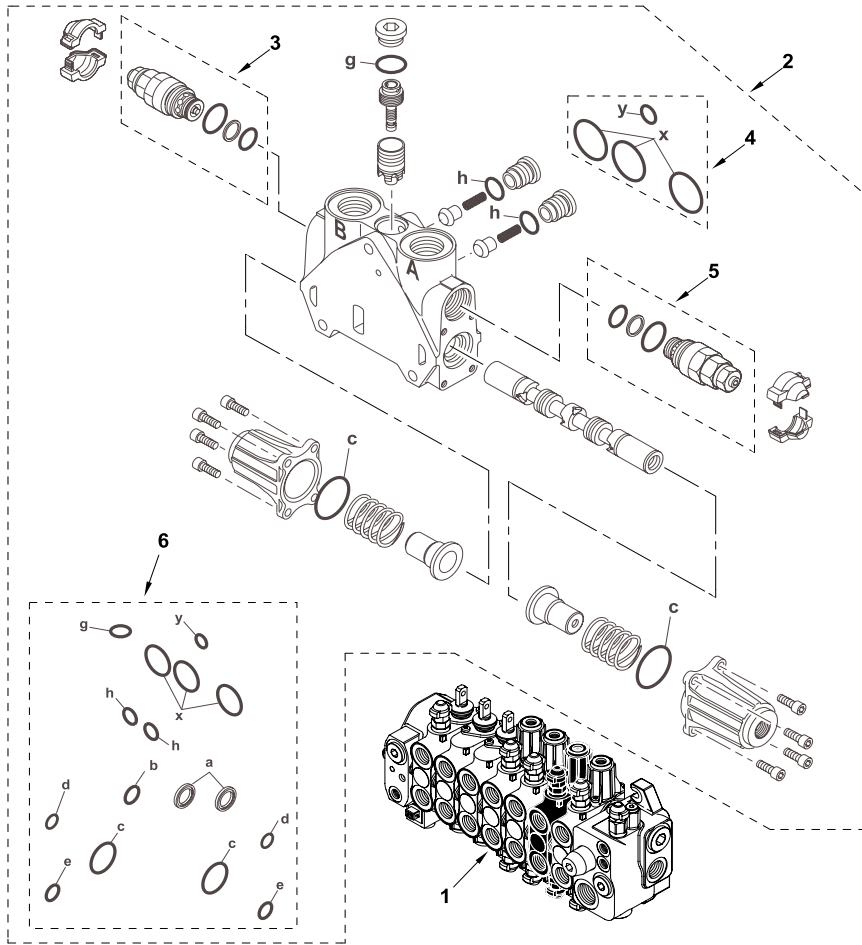

860 880 970 980
 TX860B

825 845 855 921 931

38009C04.1

6199042M3

1

Jan-06

Hydraulic Valve
Distributeur de Commande Hydraulique
Distribuidor de mando hidráulico

Backhoe Control
Godet Rétro
Equipo retro

Sideshift digger installation
 Installation montage de pelle latéral
 La Instalación excavadora de montaje horizontal

Servo
 Servo
 Servo

C-38009-05.1-A

1	6110918M91		1	Valve Assy, Control	Ensemble distribution	Distribuidor, Conj.
2	6194527M91		1	Element - Dipper		
3	6193802M91		1	265 Bar PRV		
4	6193771M91	Interface	1	Kit, Seal	Pochette de joints	Juego de juntas
5	6193808M91		1	280 Bar PRV		
6	6193781M91		1	Kit, Seal	Pochette de joints	Juego de juntas

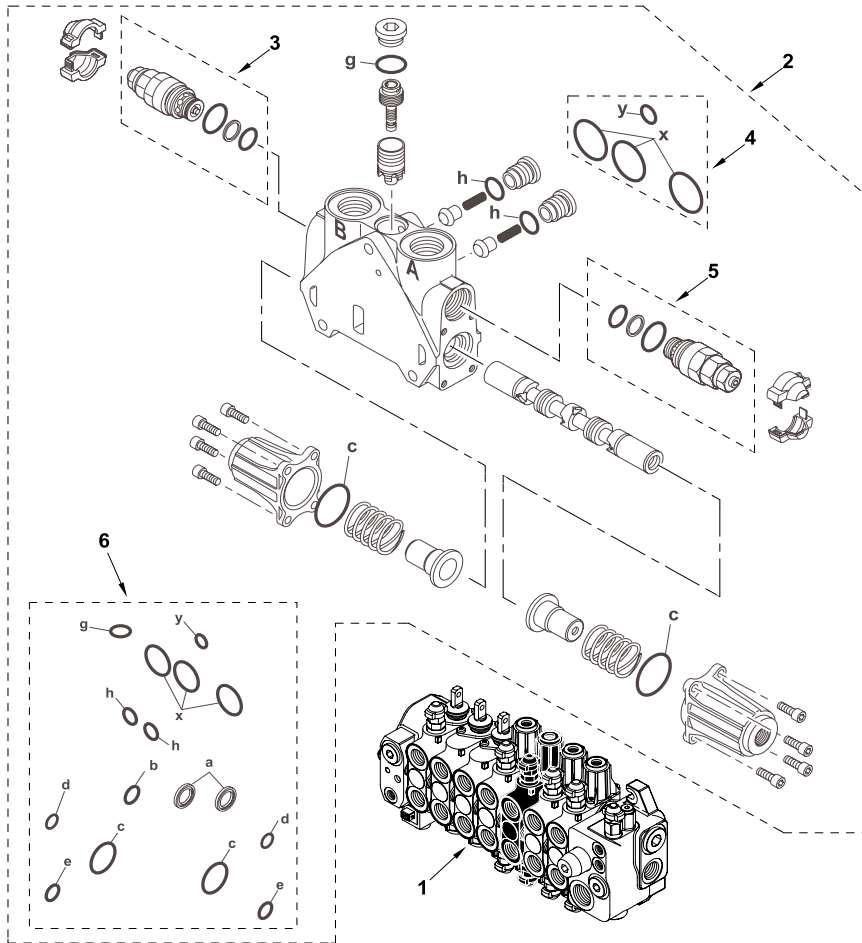

860 880 970 980
 TX860B

825 845 855 921 931

38009C05.1

6199042M3

1

Jan-06

Hydraulic Valve
Distributeur de Commande Hydraulique
Distribuidor de mando hidráulico

Backhoe Control
Godet Rétro
Equipo retro

Sideshift digger installation
 Installation montage de pelle latéral
 La Instalación excavadora de montaje horizontal

Servo
 Servo
 Servo

C-38009-06.1-A

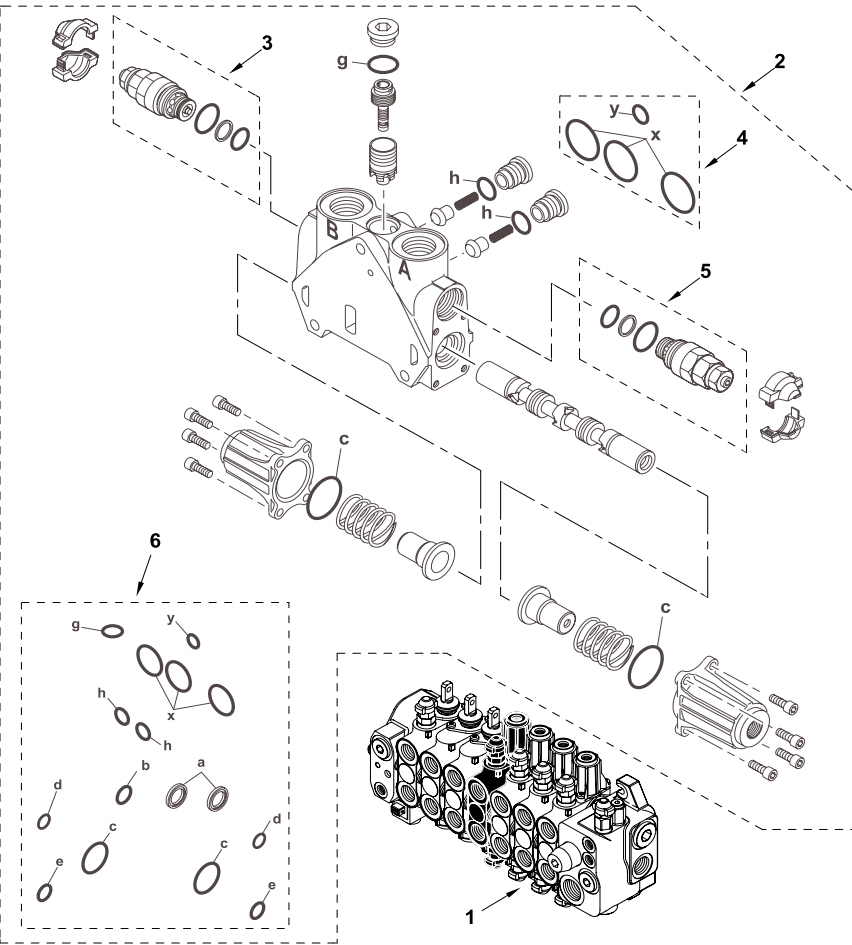

1	6110918M91			1	Valve Assy, Control	Ensemble distribution	Distribuidor, Conj.
2	6194528M91			1	Element - Bucket		
3	6193805M91			1	280 Bar PRV		
4	6193771M91	Interface		1	Kit, Seal	Pochette de joints	Juego de juntas
5	6193805M91			1	280 Bar PRV		
6	6193781M91			1	Kit, Seal	Pochette de joints	Juego de juntas



860 880 970 980
 TX860B

825 845 855 921 931

38009C06.1

6199042M3

1

Jan-06

Hydraulic Valve
Distributeur de Commande Hydraulique
Distribuidor de mando hidráulico

Backhoe Control
Godet Rétro
Equipo retro

Sideshift digger installation
 Installation montage de pelle latéral
 La Instalación excavadora de montaje horizontal

Servo
 Servo
 Servo

C-38009-07.1-A

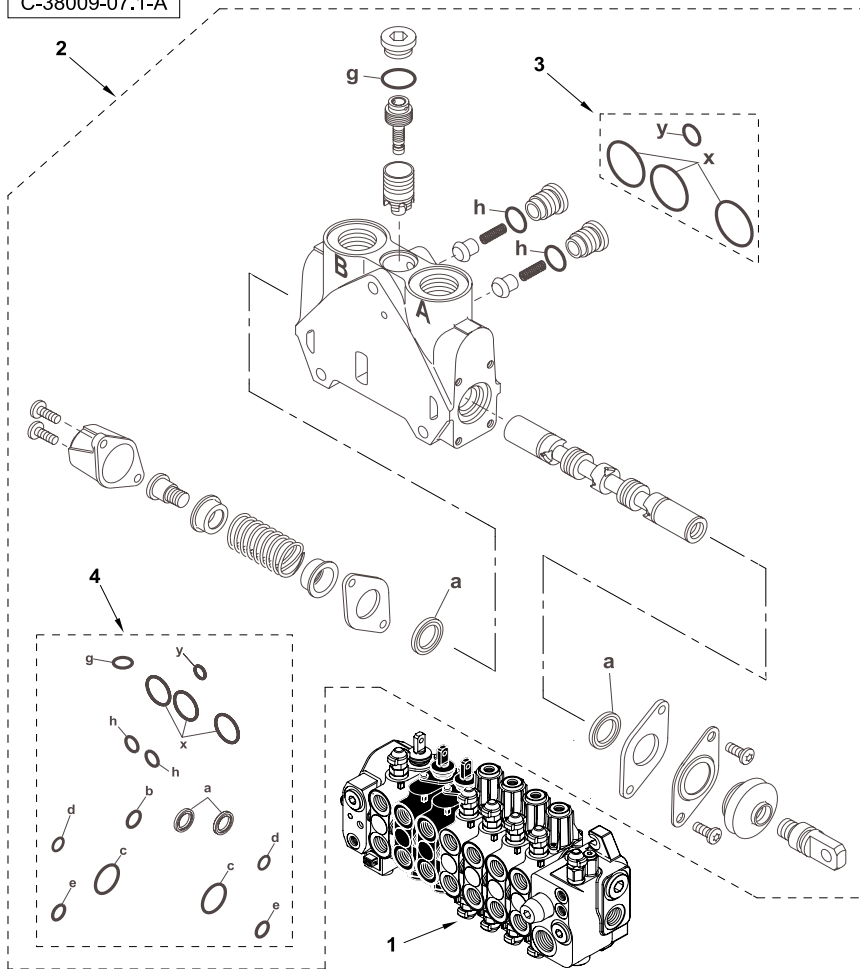

1	6110918M91		1	Valve Assy, Control	Ensemble distribution	Distribuidor, Conj.
2	6194523M91		1	Element - Stabiliser		
3	6193771M91	Interface	1	Kit, Seal	Pochette de joints	Juego de juntas
4	6193781M91		1	Kit, Seal	Pochette de joints	Juego de juntas



860 880 970 980
 TX860B

825 845 855 921 931

38009C07.1

6199042M3

1

Jan-06

Hydraulic Valve
Distributeur de Commande Hydraulique
Distribuidor de mando hidráulico

Backhoe Control
Godet Rétro
Equipo retro

Sideshift digger installation
 Installation montage de pelle latéral
 La Instalación excavadora de montaje horizontal

Servo
 Servo
 Servo

C-38009-08.1-A

1	6110918M91		1	Valve Assy, Control	Ensemble distribution	Distribuidor, Conj.
2	6194524M91		1	Element - Telescope		
3	6193785M91		1	Plug Assy	Ensemble bouchons	Tapón, Conj.
4	6193771M91	Interface	1	Kit, Seal	Pochette de joints	Juego de juntas
5	6193799M91		1	155 Bar PRV		
6	6193781M91		1	Kit, Seal	Pochette de joints	Juego de juntas

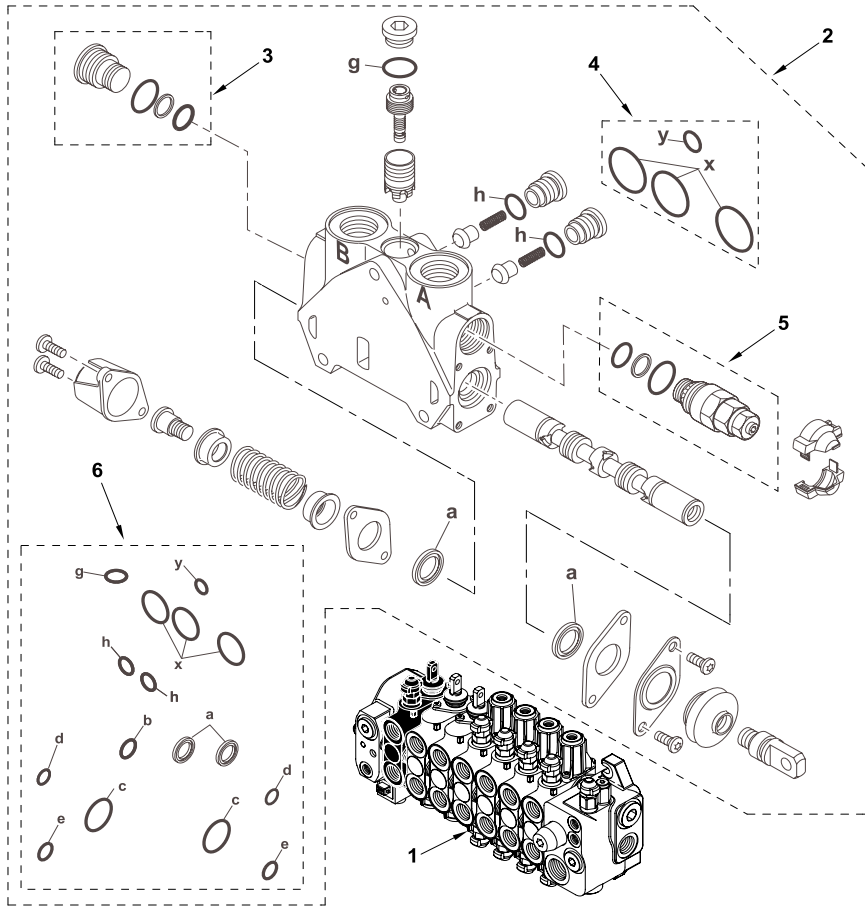

860 880 970 980
 TX860B

825 845 855 921 931

38009C08.1

6199042M3

1

Jan-06

Hydraulic Valve
Distributeur de Commande Hydraulique
Distribuidor de mando hidráulico

Backhoe Control
Godet Rétro
Equipo retro

Sideshift digger installation
 Installation montage de pelle latéral
 La Instalación excavadora de montaje horizontal

Servo
 Servo
 Servo

C-38009-09.1-A

1	6110918M91		1	Valve Assy, Control	Ensemble distribution	Distribuidor, Conj.
2	6194513M91		1	Element - Outlet		
3	6193771M91	Interface	1	Kit, Seal	Pochette de joints	Juego de juntas

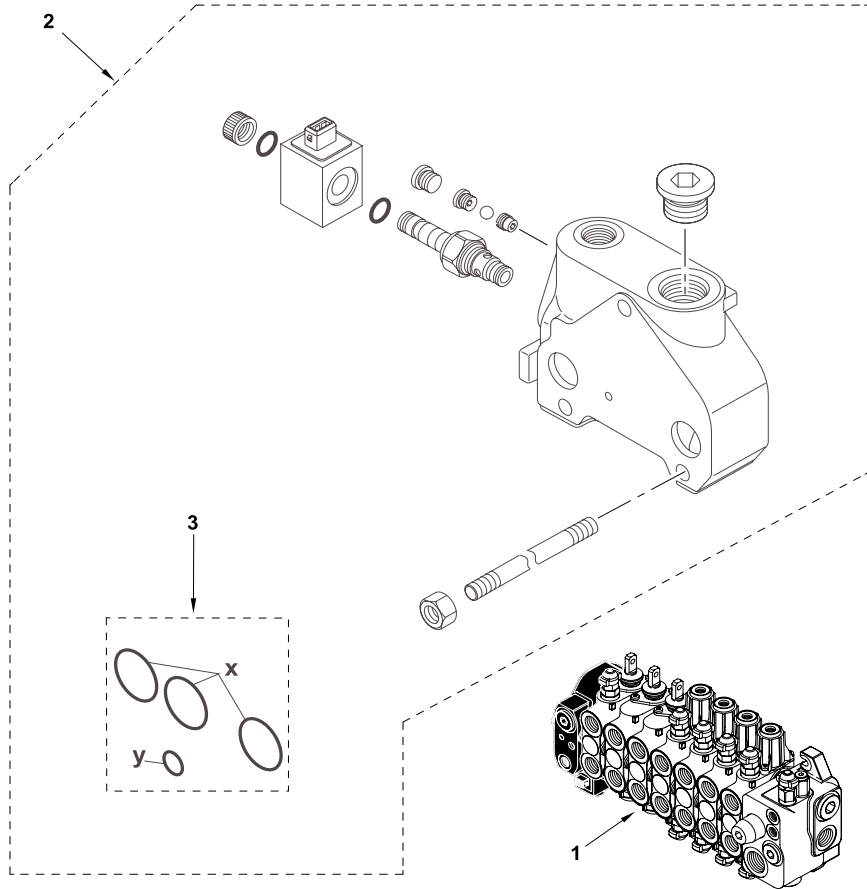

860 880 970 980
 TX860B

825 845 855 921 931

38009C09.1

6199042M3

1

Jan-06

Hydraulic Valve
Distributeur de Commande Hydraulique
Distribuidor de mando hidráulico

Backhoe Control
Godet Rétro
Equipo retro

Sideshift digger installation
 Installation montage de pelle latéral
 La Instalación excavadora de montaje horizontal

Servo
 Servo
 Servo

C-38010-01.1-A

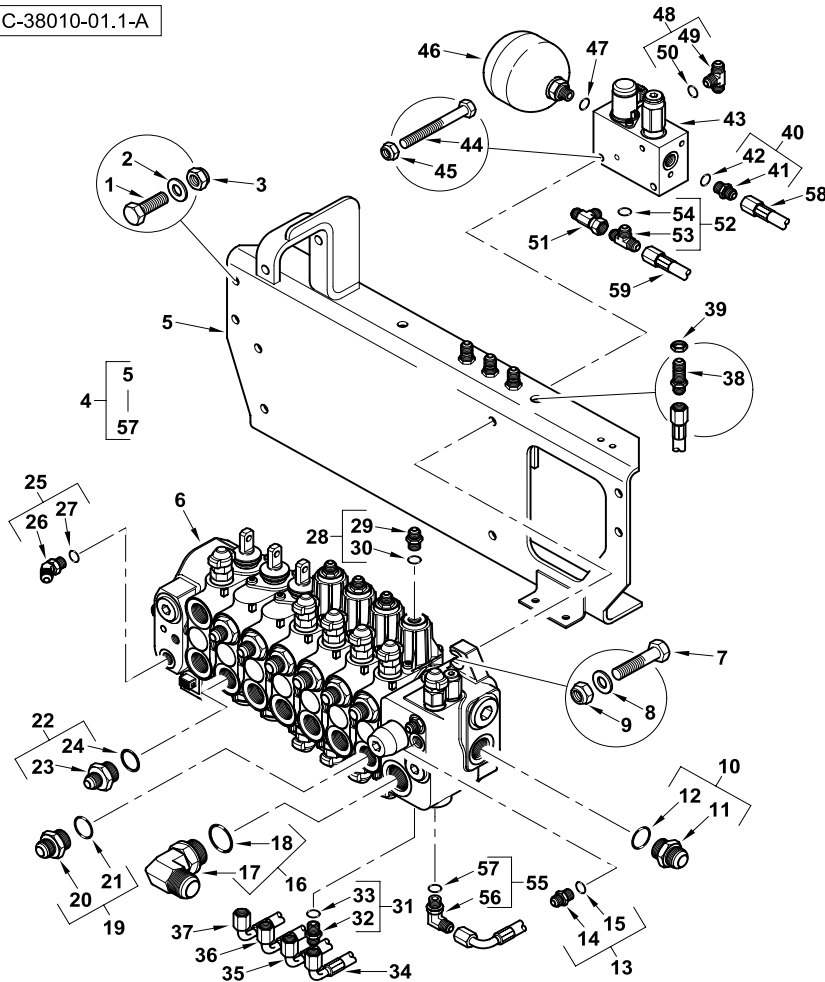

1	3009493X1	M10 x 30	4	Bolt	Boulon	Perno
2	385362X1	M10	4	Washer	Rondelle	Arandela
3	1440329X1	M10	4	Nut, Lock	Écrou de blocage	Tuerca de retención
4	6110925M91	(A)	1	Valve Assy, Control	Ensemble distribution	Distribuidor, Conj.
5	6110773M91	4	1	Bracket Assy	Ensemble chaise palier	Cuchara, Conj.
6	6110918M91	4	1	Valve Assy, Control	Ensemble distribution	Distribuidor, Conj.
7	3009496X1	4 M10 x 45	3	Screw	Vis	Tornillo
8	385362X1	4 M10	3	Washer	Rondelle	Arandela
9	1440329X1	4 M10	3	Nut, Lock	Écrou de blocage	Tuerca de retención
10	835057M91	4	1	Connector Assy	Ensemble connexion	Conexión, Conj.
11		Ref. 10	1	Union	Union	Unión
12	835025M1	10	1	O-Ring	Joint torique	Junta de tipo O
13	835091M91	4 9/16	2	Union	Union	Unión
14		Ref. 13	1	Union	Union	Unión
15	831452M1	13	1	O-Ring	Joint torique	Junta de tipo O
16	358766X91	4	1	Elbow, 90°	Coude à 90°	Codo, 90°
17		Ref. 16	1	Elbow	Coude	Codo
18	835026M1	16	1	O-Ring	Joint torique	Junta de tipo O
19	365715X91	4 1,1/16" - 7/8" UNF	8	Connector Assy	Ensemble connexion	Conexión, Conj.
20		Ref. 19	1	Union	Union	Unión
21	835025M1	19	1	O-Ring	Joint torique	Junta de tipo O
22	365713X91	4	4	Union	Union	Unión
23		Ref. 22	1	Union	Union	Unión
24	835025M1	22	1	O-Ring	Joint torique	Junta de tipo O
25	358781X91	4	1	Elbow, 45°	Coude à 45°	Codo, 45°
26		Ref. 28	1	Elbow	Coude	Codo
27	831452M1	25	1	O-Ring	Joint torique	Junta de tipo O
28	835091M91	4 9/16	4	Union	Union	Unión
29		Ref. 28	1	Union	Union	Unión
30	831452M1	28	1	O-Ring	Joint torique	Junta de tipo O
31	835091M91	4 9/16	4	Union	Union	Unión
32		Ref. 31	1	Union	Union	Unión
33	831452M1	31	1	O-Ring	Joint torique	Junta de tipo O
34	6110932M91	4 Slew	1	Hose Assy	Ensemble de flexible	Flexible, Conj.
35	6110930M91	4 Boom	1	Hose Assy	Ensemble de flexible	Flexible, Conj.
36	6110929M91	4 Dipper	1	Hose Assy	Ensemble de flexible	Flexible, Conj.
37	6110931M91	4 Bucket	1	Hose Assy	Ensemble de flexible	Flexible, Conj.
38	356266X1	4 Bulkhead	4	Union	Union	Unión
39	355830X1	4	4	Nut	Écrou	Tuerca
40	835091M91	4 9/16	1	Union	Union	Unión
41		Ref. 40	1	Union	Union	Unión
42	831452M1	40	1	O-Ring	Joint torique	Junta de tipo O
43	6110815M91	4	1	Valve, Pressure	Soupape de pression	Válvula de presión
44	390246X1	4 M8 x 70	2	Bolt	Boulon	Perno



860 880 970 980
 TX760B TX860B
 TX970B

825 831 832 833 834 845 855 921 931 932

38010C01.1

6199042M3

1

Jan-06

Hydraulic Valve
Distributeur de Commande Hydraulique
Distribuidor de mando hidráulico

Backhoe Control
Godet Rétro
Equipo retro

Sideshift digger installation
 Installation montage de pelle latéral
 La Instalación excavadora de montaje horizontal

Servo
 Servo
 Servo

C-38010-01.1-A

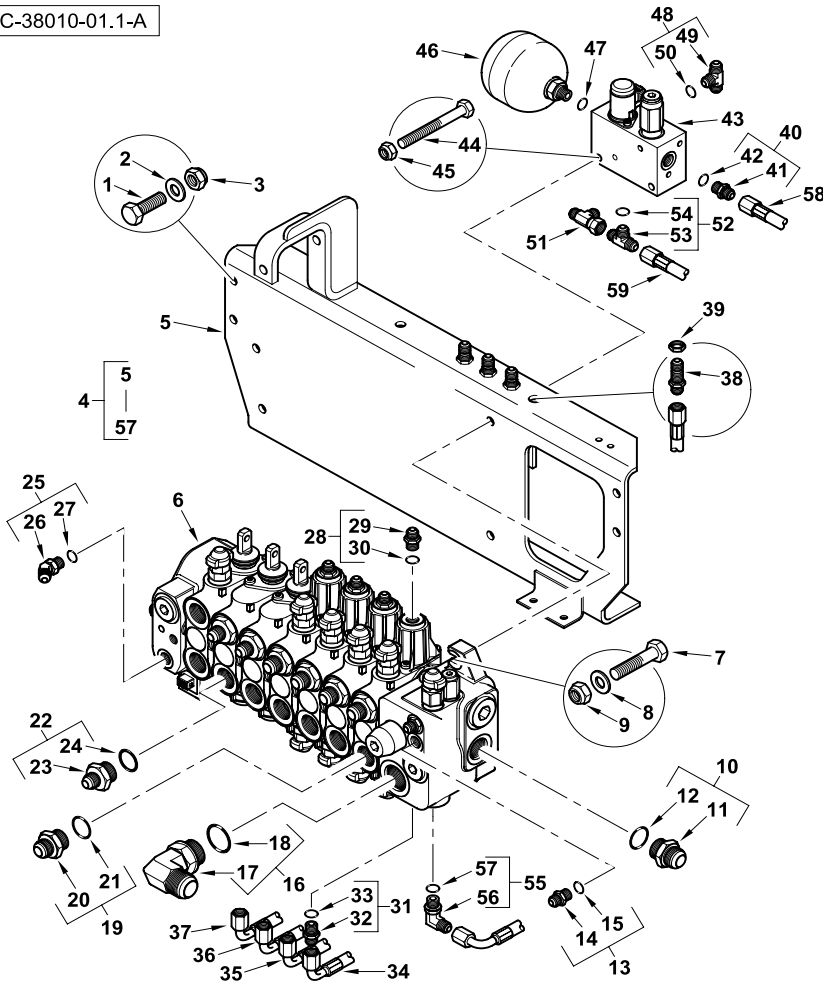

45	339009X1	4	M8 x 35	2	Screw	Vis	Tornillo
46	6110914M91	4		1	Accumulator	Accumulateur	Acumulador
47	831452M1	4		1	O-Ring	Joint torique	Junta de tipo O
48	358828X91	4		1	Union	Union	Unión
49		48	Ref. 48	1	Tee	Raccord en T	Te
50	831452M1	48		1	O-Ring	Joint torique	Junta de tipo O
51	370576X1	4		1	Tee	Raccord en T	Te
52	358828X91	4		1	Union	Union	Unión
53		52	Ref. 52	1	Tee	Raccord en T	Te
54	831452M1	52		1	O-Ring	Joint torique	Junta de tipo O
55	357197X91	4		5	Elbow, 90°	Coude à 90°	Codo, 90°
56		55	Ref. 55	1	Elbow	Coude	Codo
57	831452M1	55		1	O-Ring	Joint torique	Junta de tipo O
58	6110912M91			1	Hose Assy	Ensemble de flexible	Flexible, Conj.
59	6110911M91			1	Hose Assy	Ensemble de flexible	Flexible, Conj.

A Without Auxiliary Hydraulics
 Sans Hydraulique Auxiliaire
 Sin hidraulico auxiliar



860 880 970 980
 TX760B TX860B
 TX970B

825 831 832 833 834 845 855 921 931 932

38010C01.1

6199042M3

1

Jan-06

Hydraulic Valve
Distributeur de Commande Hydraulique
Distribuidor de mando hidráulico

Backhoe Control
Godet Rétro
Equipo retro

Sideshift digger installation
 Installation montage de pelle latéral
 La Instalación excavadora de montaje horizontal

Servo
 Servo
 Servo

C-38010-02.1-A

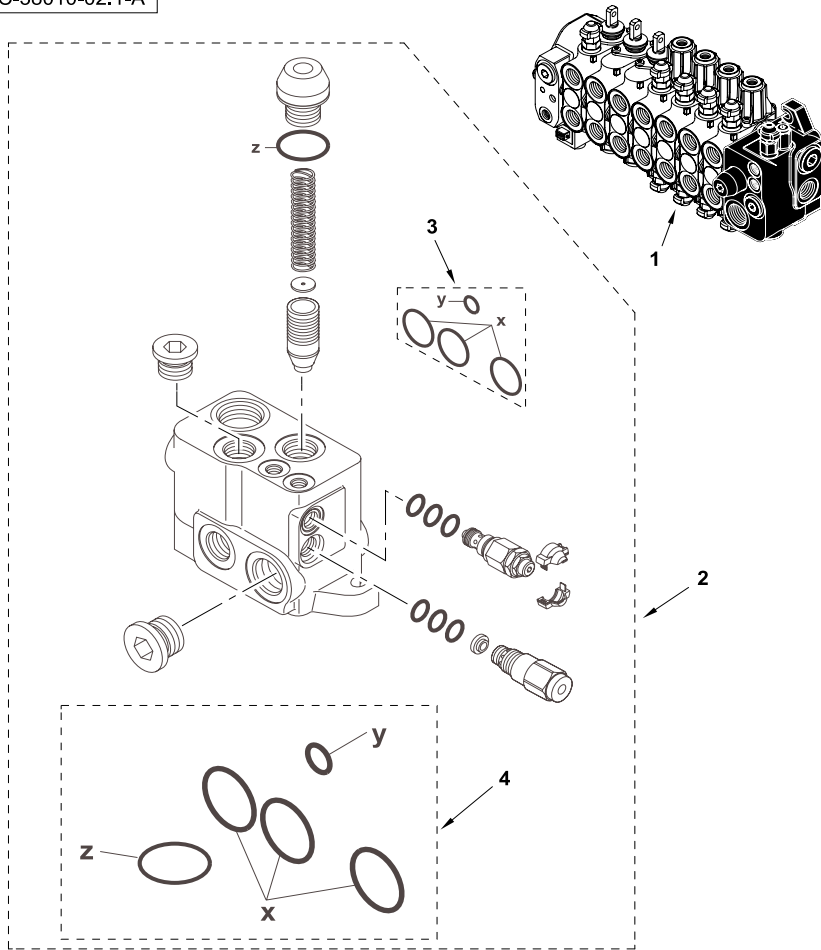

1	6110918M91		1	Valve Assy, Control	Ensemble distribution	Distribuidor, Conj.
2	6194534M91		1	Element - Inlet		
3	6193771M91	Interface	1	Kit, Seal	Pochette de joints	Juego de juntas
4	6193789M91	Inlet element	1	Kit, Seal	Pochette de joints	Juego de juntas



860 880 970 980
 TX760B TX860B
 TX970B

825 831 832 833 834 845 855 921 931 932

38010C02.1

6199042M3

1

Jan-06

Hydraulic Valve
Distributeur de Commande Hydraulique
Distribuidor de mando hidráulico

Backhoe Control
Godet Rétro
Equipo retro

Sideshift digger installation
 Installation montage de pelle latéral
 La Instalación excavadora de montaje horizontal

Servo
 Servo
 Servo

C-38010-03.1-A

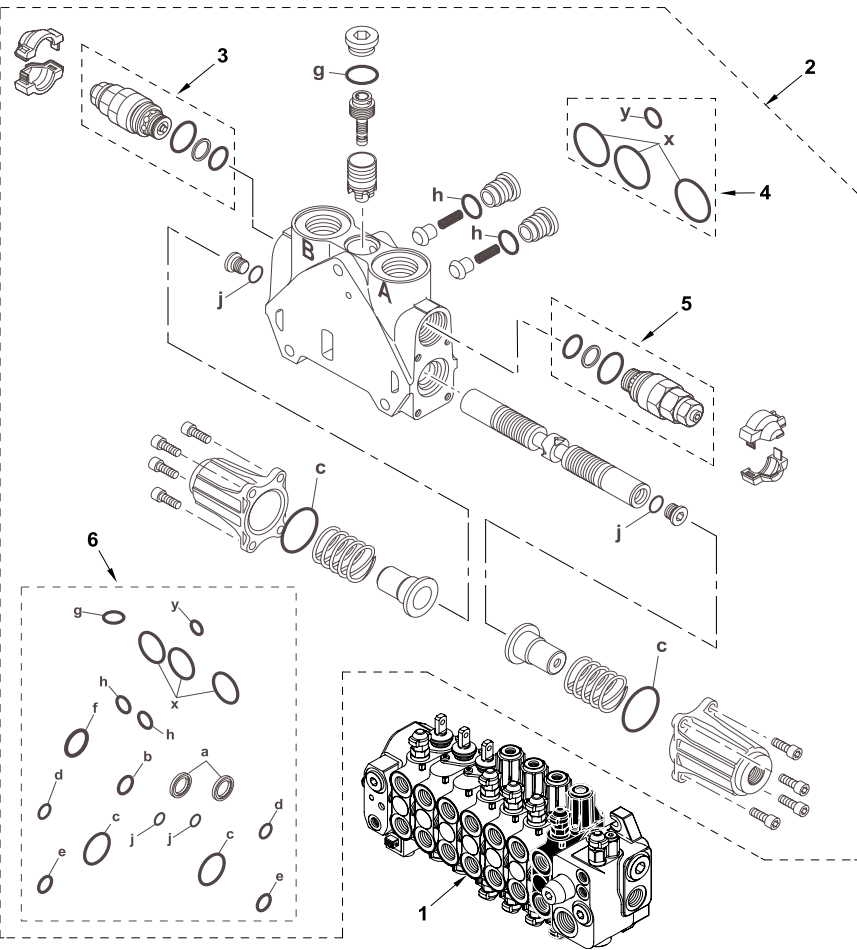

1	6110918M91		1	Valve Assy, Control	Ensemble distribution	Distribuidor, Conj.
2	6194525M91		1	Element - Slew		
3	6193800M91		1	240 Bar PRV		
4	6193771M91	Interface	1	Kit, Seal	Pochette de joints	Juego de juntas
5	6193800M91		1	240 Bar PRV		
6	6193789M91	Inlet element	1	Kit, Seal	Pochette de joints	Juego de juntas



860 880 970 980
 TX760B TX860B
 TX970B

825 831 832 833 834 845 855 921 931 932

38010C03.1

6199042M3

1

Jan-06

Hydraulic Valve
Distributeur de Commande Hydraulique
Distribuidor de mando hidráulico

Backhoe Control
Godet Rétro
Equipo retro

Sideshift digger installation
 Installation montage de pelle latéral
 La Instalación excavadora de montaje horizontal

Servo
 Servo
 Servo

C-38010-04.1-A

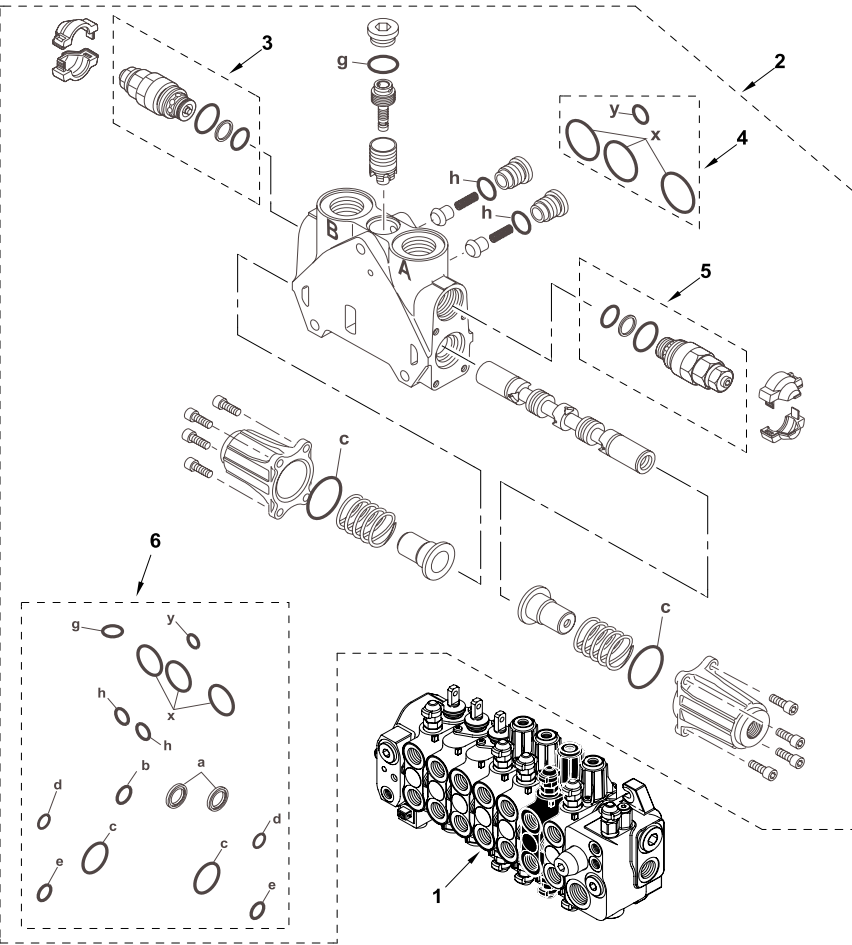

1	6110918M91			1	Valve Assy, Control	Ensemble distribution	Distribuidor, Conj.
2	6194526M91			1	Element - Boom		
3	6193804M91			1	310 Bar PRV		
4	6193771M91	Interface		1	Kit, Seal	Pochette de joints	Juego de juntas
5	6193800M91			1	240 Bar PRV		
6	6193781M91			1	Kit, Seal	Pochette de joints	Juego de juntas



860 880 970 980
 TX760B TX860B
 TX970B

825 831 832 833 834 845 855 921 931 932

38010C04.1

6199042M3

1

Jan-06

Hydraulic Valve
Distributeur de Commande Hydraulique
Distribuidor de mando hidráulico

Backhoe Control
Godet Rétro
Equipo retro

Sideshift digger installation
 Installation montage de pelle latéral
 La Instalación excavadora de montaje horizontal

Servo
 Servo
 Servo

C-38010-05.1-A

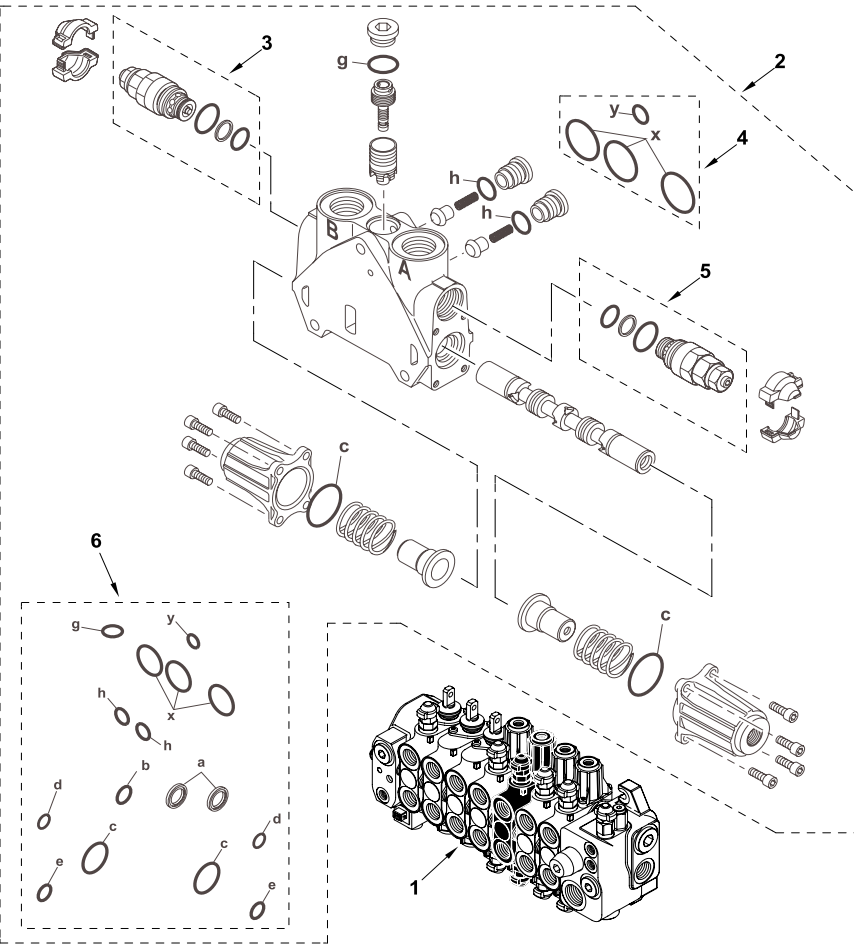

1	6110918M91			1	Valve Assy, Control	Ensemble distribution	Distribuidor, Conj.
2	6194527M91			1	Element - Dipper		
3	6193802M91			1	265 Bar PRV		
4	6193771M91	Interface		1	Kit, Seal	Pochette de joints	Juego de juntas
5	6193808M91			1	280 Bar PRV		
6	6193781M91			1	Kit, Seal	Pochette de joints	Juego de juntas



860 880 970 980
 TX760B TX860B
 TX970B

825 831 832 833 834 845 855 921 931 932

38010C05.1

6199042M3

1

Jan-06

Hydraulic Valve
Distributeur de Commande Hydraulique
Distribuidor de mando hidráulico

Backhoe Control
Godet Rétro
Equipo retro

Sideshift digger installation
 Installation montage de pelle latéral
 La Instalación excavadora de montaje horizontal

Servo
 Servo
 Servo

C-38010-06.1-A

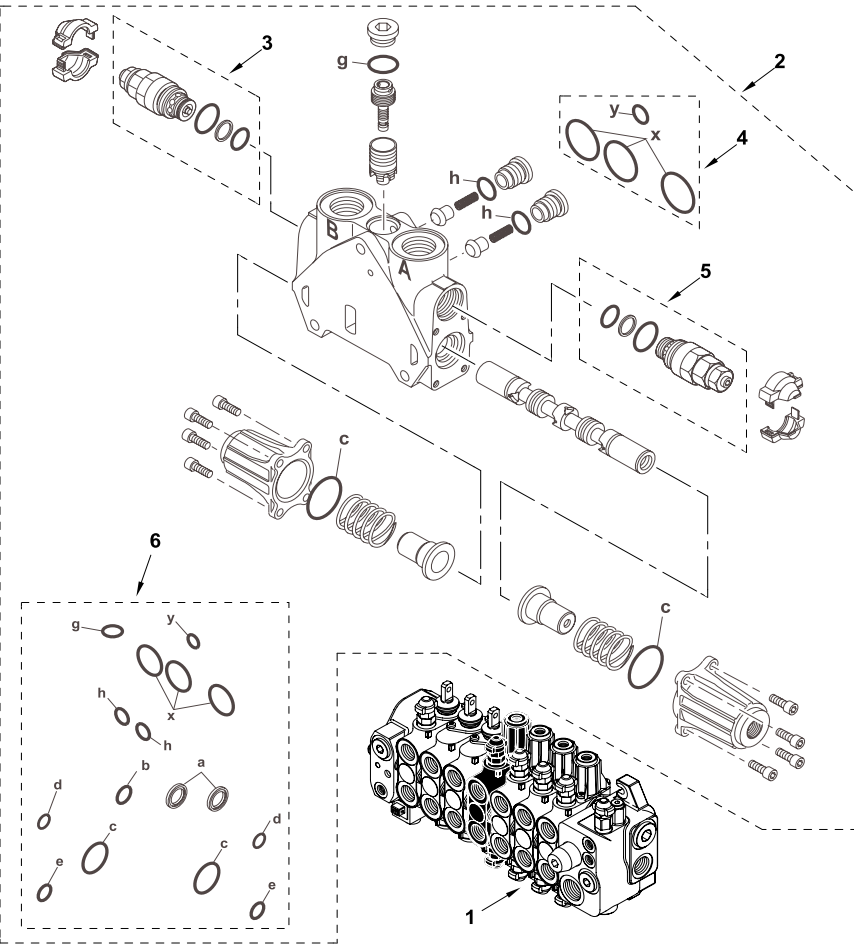

1	6110918M91			1	Valve Assy, Control	Ensemble distribution	Distribuidor, Conj.
2	6194528M91			1	Element - Bucket		
3	6193805M91			1	280 Bar PRV		
4	6193771M91	Interface		1	Kit, Seal	Pochette de joints	Juego de juntas
5	6193805M91			1	280 Bar PRV		
6	6193781M91			1	Kit, Seal	Pochette de joints	Juego de juntas



860 880 970 980
 TX760B TX860B
 TX970B

825 831 832 833 834 845 855 921 931 932

38010C06.1

6199042M3

1

Jan-06

Hydraulic Valve
Distributeur de Commande Hydraulique
Distribuidor de mando hidráulico

Backhoe Control
Godet Rétro
Equipo retro

Sideshift digger installation
 Installation montage de pelle latéral
 La Instalación excavadora de montaje horizontal

Servo
 Servo
 Servo

C-38010-07.1-A

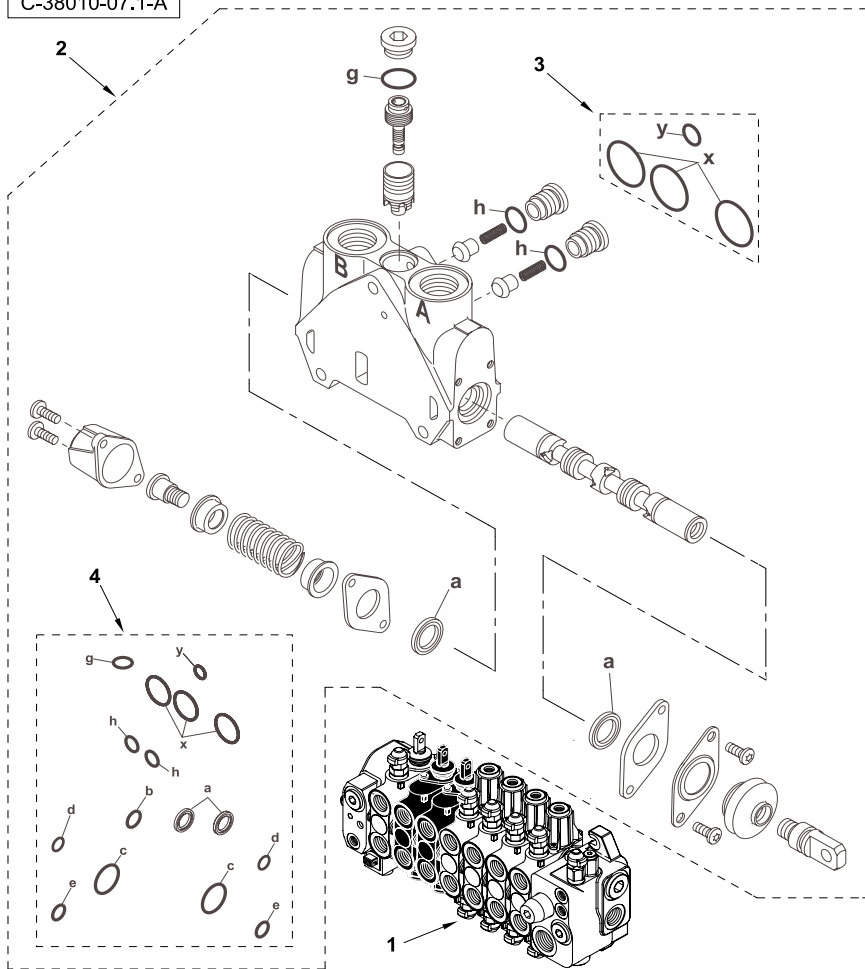

1	6110918M91		1	Valve Assy, Control	Ensemble distribution	Distribuidor, Conj.
2	6194523M91		1	Element - Stabiliser		
3	6193771M91	Interface	1	Kit, Seal	Pochette de joints	Juego de juntas
4	6193781M91		1	Kit, Seal	Pochette de joints	Juego de juntas



860 880 970 980
 TX760B TX860B
 TX970B

825 831 832 833 834 845 855 921 931 932

38010C07.1

6199042M3

1

Jan-06

Hydraulic Valve
Distributeur de Commande Hydraulique
Distribuidor de mando hidráulico

Backhoe Control
Godet Rétro
Equipo retro

Sideshift digger installation
 Installation montage de pelle latéral
 La Instalación excavadora de montaje horizontal

Servo
 Servo
 Servo

C-38010-08.1-A

1	6110918M91		1	Valve Assy, Control	Ensemble distribution	Distribuidor, Conj.
2	6194524M91		1	Element - Telescope		
3	6193785M91		1	Plug Assy	Ensemble bouchons	Tapón, Conj.
4	6193771M91	Interface	1	Kit, Seal	Pochette de joints	Juego de juntas
5	6193799M91		1	155 Bar PRV		
6	6193781M91		1	Kit, Seal	Pochette de joints	Juego de juntas

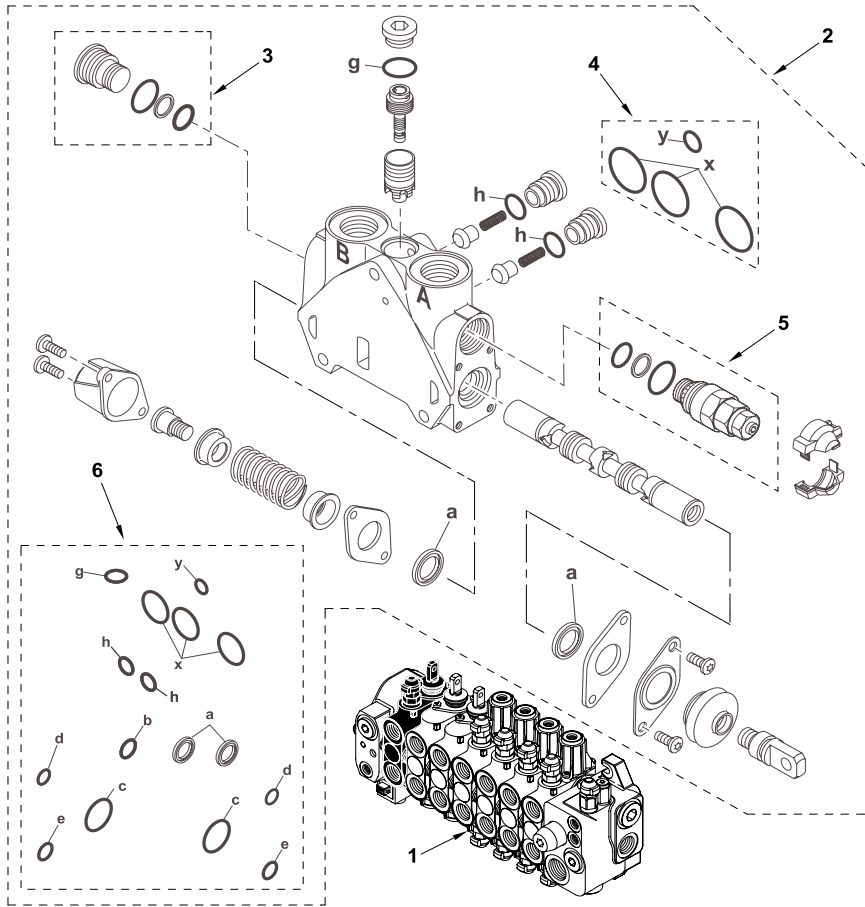

860 880 970 980
 TX760B TX860B
 TX970B

825 831 832 833 834 845 855 921 931 932

38010C08.1

6199042M3

1

Jan-06

Hydraulic Valve
Distributeur de Commande Hydraulique
Distribuidor de mando hidráulico

Backhoe Control
Godet Rétro
Equipo retro

Sideshift digger installation
 Installation montage de pelle latéral
 La Instalación excavadora de montaje horizontal

Servo
 Servo
 Servo

C-38010-09.1-A

1	6110918M91		1	Valve Assy, Control	Ensemble distribution	Distribuidor, Conj.
2	6194513M91		1	Element - Outlet		
3	6193771M91	Interface	1	Kit, Seal	Pochette de joints	Juego de juntas

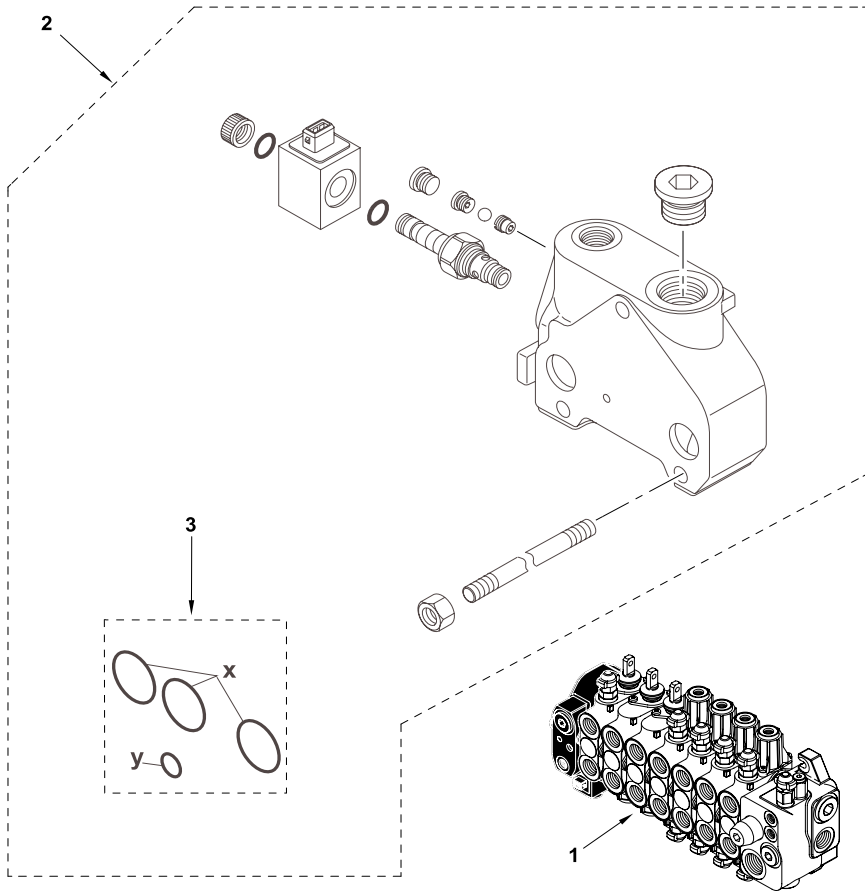

860 880 970 980
 TX760B TX860B
 TX970B

825 831 832 833 834 845 855 921 931 932

38010C09.1

6199042M3

1

Jan-06

Main Hydraulics
Système Hydraulique
Sistema hidráulico

Hydraulic Lines
Tuyaux Hydrauliques
Circuito hidráulico

Synchro Shuttle
Synchro Shuttle
Synchro Shuttle

C-40001-01.1-B

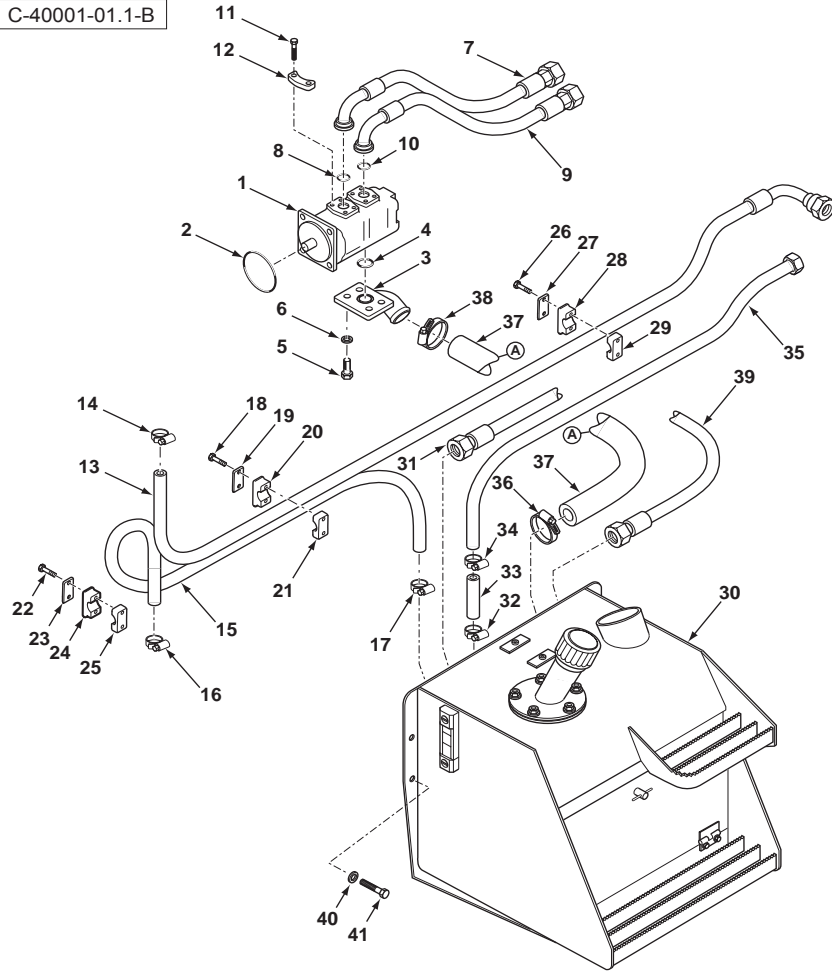

1	6109163M91	40001C06.1 1 140 LT	1	Pump, Hydraulic	Pompe hydraulique	Bomba hidráulica
2	6109215M1		1	O-Ring	Joint torique	Junta de tipo O
3	6109377M1		1	Block, Elbow	Bloc équerre	Bloque codo
4	359134X1		1	O-Ring	Joint torique	Junta de tipo O
5	1440356X1	M12 x 30	4	Screw	Vis	Tornillo
6	339369X1	M12	4	Washer, Lock	Rondelle de blocage	Arandela de freno
7	6109122M91		1	Hose Assy	Ensemble de flexible	Flexible, Conj.
8	851145M1		1	O-Ring	Joint torique	Junta de tipo O
9	6109122M91		1	Hose Assy	Ensemble de flexible	Flexible, Conj.
10	851145M1		1	O-Ring	Joint torique	Junta de tipo O
11	3009493X1	M10 x 30	8	Bolt	Boulon	Perno
12	3521551M1		4	Bracket, Clamp	Bride de fixation	Brida de fijación
13	6109056M91		1	Hose Assy	Ensemble de flexible	Flexible, Conj.
14	3517410M1		1	Clip	Clip	Clip
15	6109689M1		1	Hose	Flexible	Tubo flexible
16	3517410M1		1	Clip	Clip	Clip
17	3517410M1		1	Clip	Clip	Clip
18	339011X1	M8 x 45	2	Bolt	Boulon	Perno
19	1470376M1		2	Plate	Plaque	Placa
20	6107502M1		2	Clamp	Collier de serrage	Argolla de cierre
21	6107502M1		2	Clamp	Collier de serrage	Argolla de cierre
22	391244X1	M6 x 45	1	Bolt	Boulon	Perno
23	1462583M1		1	Plate	Plaque	Placa
24	1462584M1		1	Clamp	Collier de serrage	Argolla de cierre
25	3520340M3		1	Clamp	Collier de serrage	Argolla de cierre
26	391244X1	M6 x 45	1	Bolt	Boulon	Perno
27	1462583M1		1	Plate	Plaque	Placa
28	1462584M1		1	Clamp	Collier de serrage	Argolla de cierre
29	3520340M3		1	Clamp	Collier de serrage	Argolla de cierre
30	6108959M94	40001C05.1 1	1	Reservoir Assy	Ensemble de réservoir	Depósito, Conj.
31	6109619M91		1	Hose Assy	Ensemble de flexible	Flexible, Conj.
32	3517738M1		1	Clip	Clip	Clip
33	6109065M1		1	Hose	Flexible	Tubo flexible
34	3517738M1		1	Clip	Clip	Clip
35	6109073M91		1	Tube Assy	Tuyauterie	Conjunto de tubería
36	3517414M1		1	Clip	Clip	Clip
37	6109243M1		1	Hose	Flexible	Tubo flexible
38	3517414M1		1	Clip	Clip	Clip
39	6109395M91		1	Hose Assy	Ensemble de flexible	Flexible, Conj.
40	391212X1	M12	4	Washer	Rondelle	Arandela
41	3009505X1	M12 x 25	4	Bolt	Boulon	Perno



820
TX760B

801 802 803 804 805 806 807 808 831 832 833 834

40001C01.1

6199042M3

1

Jan-06

Main Hydraulics
Système Hydraulique
Sistema hidráulico

Hydraulic Lines
Tuyaux Hydrauliques
Circuito hidráulico

Synchro Shuttle
Synchro Shuttle
Synchro Shuttle

C-40001-02.1-A

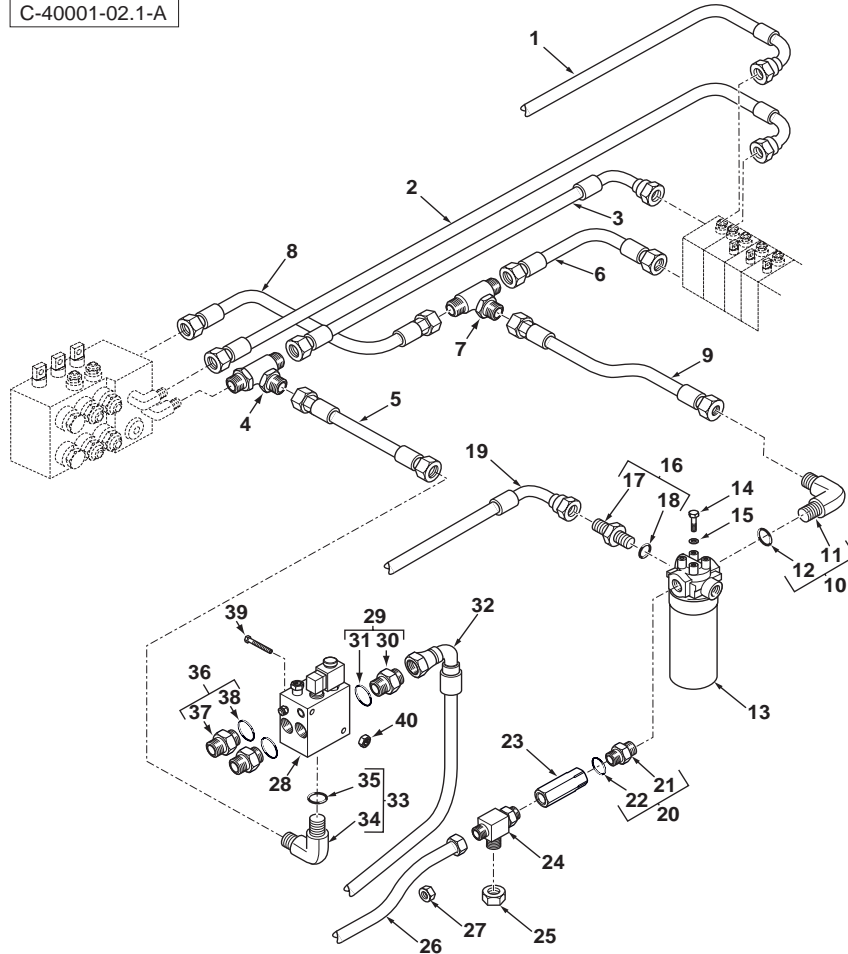

1	6109395M91		1	Hose Assy	Ensemble de flexible	Flexible, Conj.
2	6109448M91		1	Hose Assy	Ensemble de flexible	Flexible, Conj.
3	6109447M91		1	Hose Assy	Ensemble de flexible	Flexible, Conj.
4	371360X1	1-1/16	1	Tee	Raccord en T	Te
5	6108189M91		1	Hose Assy	Ensemble de flexible	Flexible, Conj.
6	6109859M91		1	Tube Assy	Tuyauterie	Conjunto de tubería
7	356564X1	1-5/16"	1	Tee	Raccord en T	Te
8	6109728M91		1	Hose Assy	Ensemble de flexible	Flexible, Conj.
9	6109728M91		1	Hose Assy	Ensemble de flexible	Flexible, Conj.
10	358766X91		1	Elbow, 90°	Coude à 90°	Codo, 90°
11		10	1	Elbow	Coude	Codo
12	835026M1	10	1	O-Ring	Joint torique	Junta de tipo O
13	6107494M91	40001C03.1 1	1	Filter, Oil	Filter à huile	Filtro de aceite
14	3009491X1	M10 x 20	2	Screw	Vis	Tornillo
15	385362X1	M10	2	Washer	Rondelle	Arandela
16	835013M91		1	Connector Assy	Ensemble connexion	Conexión, Conj.
17		16	1	Union	Union	Unión
18	835024M1	16	1	O-Ring	Joint torique	Junta de tipo O
19	6109056M91		1	Hose Assy	Ensemble de flexible	Flexible, Conj.
20	6109845M91	1-5/8 - 1-5/16	1	Connector Assy	Ensemble connexion	Conexión, Conj.
21		20	1	Union	Union	Unión
22		20	1	O-Ring	Joint torique	Junta de tipo O
23	6108685M91		1	Valve, Check	Clapet anti-retour	Válvula de parada
24	358748X91	1-5/16"	1	Tee	Raccord en T	Te
25	356582X1		1	Cap	Chapeau	Sombbrero
26	6109073M91		1	Tube Assy	Tuyauterie	Conjunto de tubería
27	356577X1		1	Cap	Chapeau	Sombbrero
28	6110446M91	40001C04.1 1	1	Valve, Control	Distributeur	Distribuidor
29	835013M91		1	Connector Assy	Ensemble connexion	Conexión, Conj.
30		29	1	Union	Union	Unión
31	835024M1	29	1	O-Ring	Joint torique	Junta de tipo O
32	6109619M91		1	Hose Assy	Ensemble de flexible	Flexible, Conj.
33	358764X91		1	Elbow, 90°	Coude à 90°	Codo, 90°
34		33	1	Elbow	Coude	Codo
35	835025M1	33	1	O-Ring	Joint torique	Junta de tipo O
36	3517847M91		2	Union	Union	Unión
37		36	1	Union	Union	Unión
38	835024M1	36	1	O-Ring	Joint torique	Junta de tipo O
39	339084X1	M8 x 100	2	Bolt	Boulon	Perno
40	394367X1	M8	2	Nut, Lock	Écrou de blocage	Tuerca de retención



820
TX760B

801 802 803 804 805 806 807 808 831 832 833 834

40001C02.1

6199042M3

1

Jan-06

Main Hydraulics
Système Hydraulique
Sistema hidráulico

Hydraulic Lines
Tuyaux Hydrauliques
Circuito hidráulico

Synchro Shuttle
Synchro Shuttle
Synchro Shuttle

C-40002-01.1-B

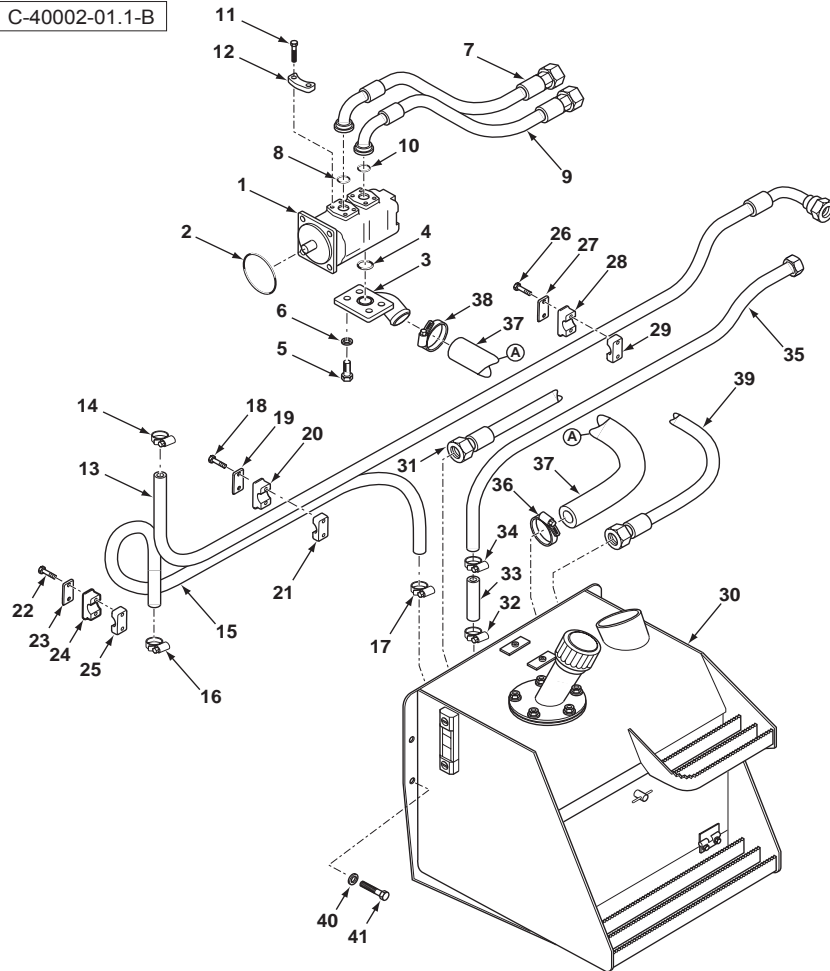

1	6109162M91	40002C06.1 1 160 LT	1	Pump, Hydraulic	Pompe hydraulique	Bomba hidráulica
2	6109215M1		1	O-Ring	Joint torique	Junta de tipo O
3	6109377M1		1	Block, Elbow	Bloc équerre	Bloque codo
4	359134X1		1	O-Ring	Joint torique	Junta de tipo O
5	1440356X1	M12 x 30	4	Screw	Vis	Tornillo
6	339369X1	M12	4	Washer, Lock	Rondelle de blocage	Arandela de freno
7	6109122M91		1	Hose Assy	Ensemble de flexible	Flexible, Conj.
8	851145M1		1	O-Ring	Joint torique	Junta de tipo O
9	6109122M91		1	Hose Assy	Ensemble de flexible	Flexible, Conj.
10	851145M1		1	O-Ring	Joint torique	Junta de tipo O
11	3009493X1	M10 x 30	8	Bolt	Boulon	Perno
12	3521551M1		4	Bracket, Clamp	Bride de fixation	Brida de fijación
13	6109056M91		1	Hose Assy	Ensemble de flexible	Flexible, Conj.
14	3517410M1		1	Clip	Clip	Clip
15	6109689M1		1	Hose	Flexible	Tubo flexible
16	3517410M1		1	Clip	Clip	Clip
17	3517410M1		1	Clip	Clip	Clip
18	339011X1	M8 x 45	2	Bolt	Boulon	Perno
19	1470376M1		2	Plate	Plaque	Placa
20	6107502M1		2	Clamp	Collier de serrage	Argolla de cierre
21	6107502M1		2	Clamp	Collier de serrage	Argolla de cierre
22	391244X1	M6 x 45	1	Bolt	Boulon	Perno
23	1462583M1		1	Plate	Plaque	Placa
24	1462584M1		1	Clamp	Collier de serrage	Argolla de cierre
25	3520340M3		1	Clamp	Collier de serrage	Argolla de cierre
26	391244X1	M6 x 45	1	Bolt	Boulon	Perno
27	1462583M1		1	Plate	Plaque	Placa
28	1462584M1		1	Clamp	Collier de serrage	Argolla de cierre
29	3520340M3		1	Clamp	Collier de serrage	Argolla de cierre
30	6108959M94	40002C05.1 1	1	Reservoir Assy	Ensemble de réservoir	Depósito, Conj.
31	6109619M91		1	Hose Assy	Ensemble de flexible	Flexible, Conj.
32	3517738M1		1	Clip	Clip	Clip
33	6109065M1		1	Hose	Flexible	Tubo flexible
34	3517738M1		1	Clip	Clip	Clip
35	6109073M91		1	Tube Assy	Tuyauterie	Conjunto de tubería
36	3517414M1		1	Clip	Clip	Clip
37	6109243M1		1	Hose	Flexible	Tubo flexible
38	3517414M1		1	Clip	Clip	Clip
39	6109395M91		1	Hose Assy	Ensemble de flexible	Flexible, Conj.
40	391212X1	M12	4	Washer	Rondelle	Arandela
41	3009505X1	M12 x 25	4	Bolt	Boulon	Perno



860 880
TX860B TX870B

809 810 811 812 813 814 815 816 817 841 842 843 844 845

40002C01.1

6199042M3

1

Jan-06

Main Hydraulics
Système Hydraulique
Sistema hidráulico

Hydraulic Lines
Tuyaux Hydrauliques
Circuito hidráulico

Synchro Shuttle
Synchro Shuttle
Synchro Shuttle

C-40002-02.1-A

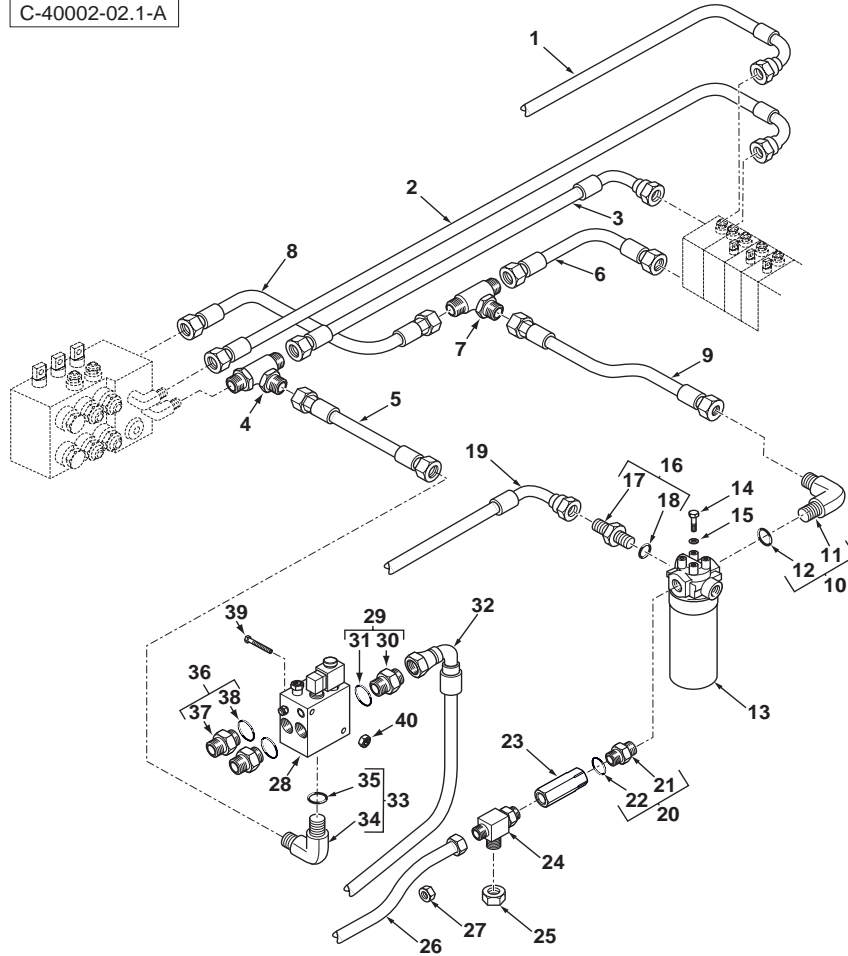

1	6109395M91			1	Hose Assy	Ensemble de flexible	Flexible, Conj.
2	6109448M91			1	Hose Assy	Ensemble de flexible	Flexible, Conj.
3	6109447M91			1	Hose Assy	Ensemble de flexible	Flexible, Conj.
4	371360X1	1-1/16		1	Tee	Raccord en T	Te
5	6108189M91			1	Hose Assy	Ensemble de flexible	Flexible, Conj.
6	6109859M91			1	Tube Assy	Tuyauterie	Conjunto de tubería
7	356564X1	1-5/16"		1	Tee	Raccord en T	Te
8	6109728M91			1	Hose Assy	Ensemble de flexible	Flexible, Conj.
9	6109728M91			1	Hose Assy	Ensemble de flexible	Flexible, Conj.
10	358766X91			1	Elbow, 90°	Coude à 90°	Codo, 90°
11		10	➡ Ref. 10	1	Elbow	Coude	Codo
12	835026M1	10		1	O-Ring	Joint torique	Junta de tipo O
13	6107494M91		👁 40002C03.1 1	1	Filter, Oil	Filtre à huile	Filtro de aceite
14	3009491X1	M10 x 20		2	Screw	Vis	Tornillo
15	385362X1	M10		2	Washer	Rondelle	Arandela
16	835013M91			1	Connector Assy	Ensemble connexion	Conexión, Conj.
17		16	➡ Ref. 16	1	Union	Union	Unión
18	835024M1	16		1	O-Ring	Joint torique	Junta de tipo O
19	6109056M91			1	Hose Assy	Ensemble de flexible	Flexible, Conj.
20	6109845M91	1-5/8 - 1-5/16		1	Connector Assy	Ensemble connexion	Conexión, Conj.
21		20	➡ Ref. 20	1	Union	Union	Unión
22		20	➡ Ref. 20	1	O-Ring	Joint torique	Junta de tipo O
23	6108685M91			1	Valve, Check	Clapet anti-retour	Válvula de parada
24	358748X91	1-5/16"		1	Tee	Raccord en T	Te
25	356582X1			1	Cap	Chapeau	Sombbrero
26	6109073M91			1	Tube Assy	Tuyauterie	Conjunto de tubería
27	356577X1			1	Cap	Chapeau	Sombbrero
28	6110446M91		👁 40002C04.1 1	1	Valve, Control	Distributeur	Distribuidor
29	835013M91			1	Connector Assy	Ensemble connexion	Conexión, Conj.
30		29	➡ Ref. 29	1	Union	Union	Unión
31	835024M1	29		1	O-Ring	Joint torique	Junta de tipo O
32	6109619M91			1	Hose Assy	Ensemble de flexible	Flexible, Conj.
33	358764X91			1	Elbow, 90°	Coude à 90°	Codo, 90°
34		33	➡ Ref. 33	1	Elbow	Coude	Codo
35	835025M1	33		1	O-Ring	Joint torique	Junta de tipo O
36	3517847M91			2	Union	Union	Unión
37		36	➡ Ref. 36	1	Union	Union	Unión
38	835024M1	36		1	O-Ring	Joint torique	Junta de tipo O
39	339084X1	M8 x 100		2	Bolt	Boulon	Perno
40	394367X1	M8		2	Nut, Lock	Écrou de blocage	Tuerca de retención



860 880
 TX860B TX870B

809 810 811 812 813 814 815 816 817 841 842 843 844 845

40002C02.1

6199042M3

1

Jan-06

Main Hydraulics
Système Hydraulique
Sistema hidráulico

Hydraulic Lines
Tuyaux Hydrauliques
Circuito hidráulico

Powershift
Powershift
Powershift

C-40003-01.1-B

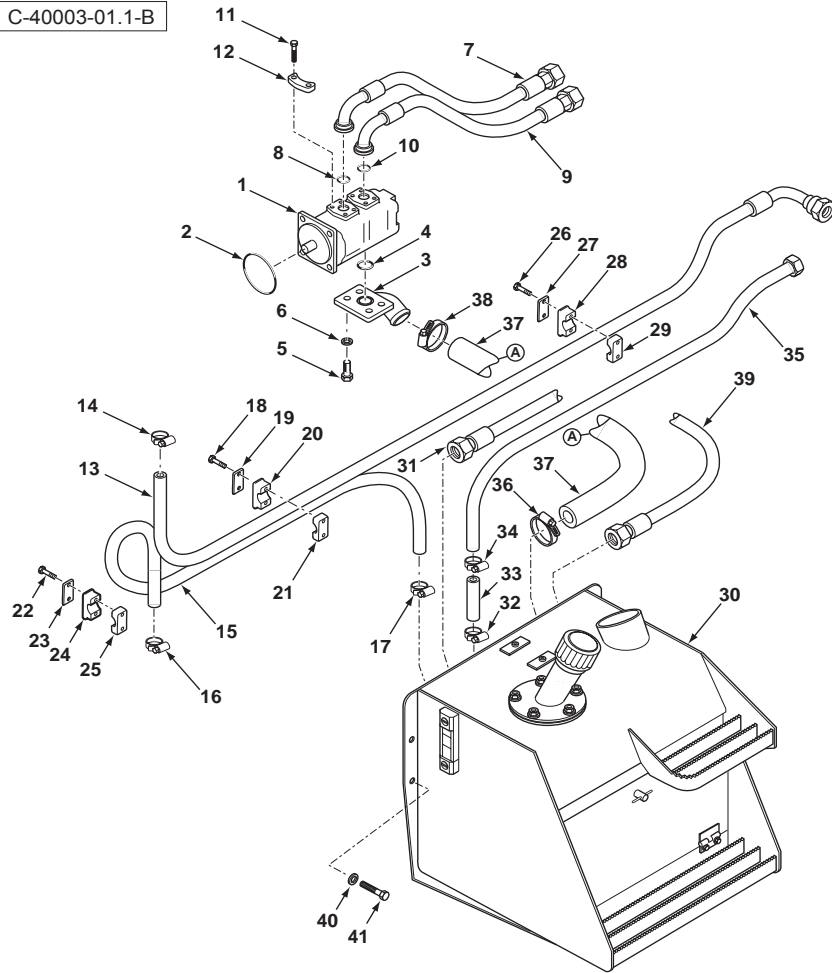

1	6109162M91	40003C06.1 1 160 LT	1	Pump, Hydraulic	Pompe hydraulique	Bomba hidráulica
2	6109215M1		1	O-Ring	Joint torique	Junta de tipo O
3	6109377M1		1	Block, Elbow	Bloc équerre	Bloque codo
4	359134X1		1	O-Ring	Joint torique	Junta de tipo O
5	1440356X1	M12 x 30	4	Screw	Vis	Tornillo
6	339369X1	M12	4	Washer, Lock	Rondelle de blocage	Arandela de freno
7	6109122M91		1	Hose Assy	Ensemble de flexible	Flexible, Conj.
8	851145M1		1	O-Ring	Joint torique	Junta de tipo O
9	6109122M91		1	Hose Assy	Ensemble de flexible	Flexible, Conj.
10	851145M1		1	O-Ring	Joint torique	Junta de tipo O
11	3009493X1	M10 x 30	8	Bolt	Boulon	Perno
12	3521551M1		4	Bracket, Clamp	Bride de fixation	Brida de fijación
13	6109056M91		1	Hose Assy	Ensemble de flexible	Flexible, Conj.
14	3517410M1		1	Clip	Clip	Clip
15	6109689M1		1	Hose	Flexible	Tubo flexible
16	3517410M1		1	Clip	Clip	Clip
17	3517410M1		1	Clip	Clip	Clip
18	339011X1	M8 x 45	2	Bolt	Boulon	Perno
19	1470376M1		2	Plate	Plaque	Placa
20	6107502M1		2	Clamp	Collier de serrage	Argolla de cierre
21	6107502M1		2	Clamp	Collier de serrage	Argolla de cierre
22	391244X1	M6 x 45	1	Bolt	Boulon	Perno
23	1462583M1		1	Plate	Plaque	Placa
24	1462584M1		1	Clamp	Collier de serrage	Argolla de cierre
25	3520340M3		1	Clamp	Collier de serrage	Argolla de cierre
26	391244X1	M6 x 45	1	Bolt	Boulon	Perno
27	1462583M1		1	Plate	Plaque	Placa
28	1462584M1		1	Clamp	Collier de serrage	Argolla de cierre
29	3520340M3		1	Clamp	Collier de serrage	Argolla de cierre
30	6108959M94	40003C05.1 1	1	Reservoir Assy	Ensemble de réservoir	Depósito, Conj.
31	6109619M91		1	Hose Assy	Ensemble de flexible	Flexible, Conj.
32	3517738M1		1	Clip	Clip	Clip
33	6109065M1		1	Hose	Flexible	Tubo flexible
34	3517738M1		1	Clip	Clip	Clip
35	6109073M91		1	Tube Assy	Tuyauterie	Conjunto de tubería
36	3517414M1		1	Clip	Clip	Clip
37	6109242M1		1	Hose	Flexible	Tubo flexible
38	3517414M1		1	Clip	Clip	Clip
39	6109395M91		1	Hose Assy	Ensemble de flexible	Flexible, Conj.
40	391212X1	M12	4	Washer	Rondelle	Arandela
41	3009505X1	M12 x 25	4	Bolt	Boulon	Perno



860 880 970 980
 TX860B TX870B
 TX970B

821 822 823 824 825 851 852 853 854 855 921 922 923 931 932

40003C01.1

6199042M3

1

Jan-06

Main Hydraulics
Système Hydraulique
Sistema hidráulico

Hydraulic Lines
Tuyaux Hydrauliques
Circuito hidráulico

Powershift
Powershift
Powershift

C-40003-02.1-A

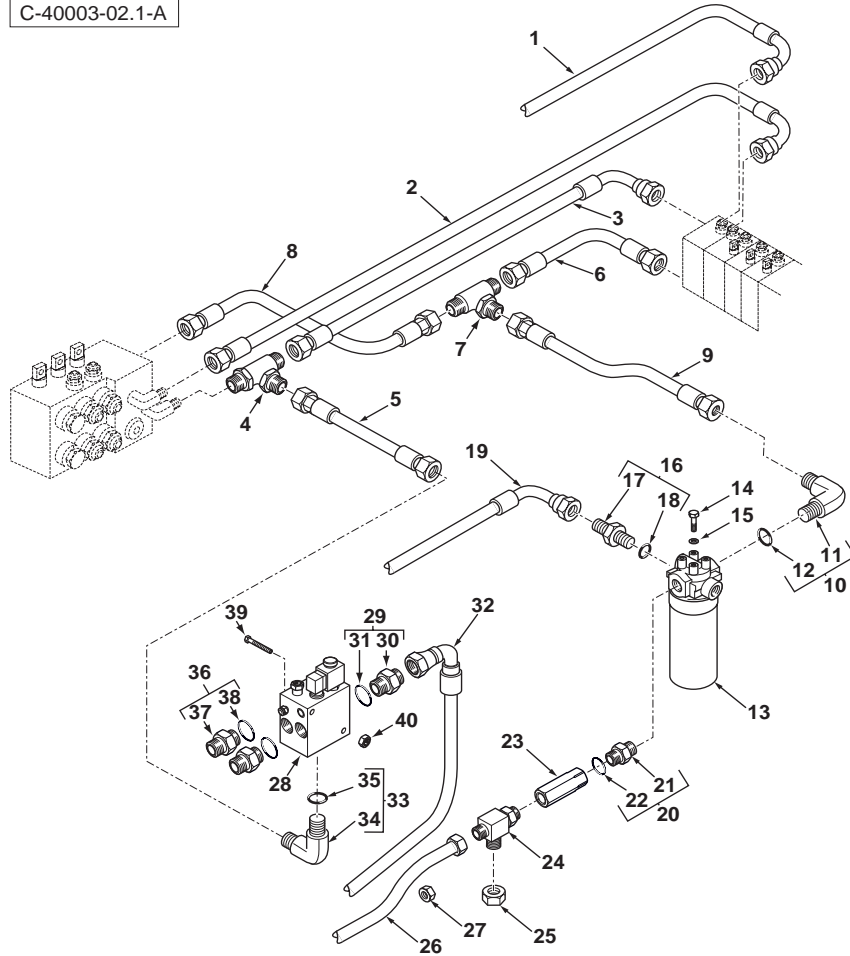

1	6109395M91			1	Hose Assy	Ensemble de flexible	Flexible, Conj.
2	6109448M91			1	Hose Assy	Ensemble de flexible	Flexible, Conj.
3	6109447M91			1	Hose Assy	Ensemble de flexible	Flexible, Conj.
4	371360X1	1-1/16		1	Tee	Raccord en T	Te
5	6108189M91			1	Hose Assy	Ensemble de flexible	Flexible, Conj.
6	6109859M91			1	Tube Assy	Tuyauterie	Conjunto de tubería
7	356564X1	1-5/16"		1	Tee	Raccord en T	Te
8	6109728M91			1	Hose Assy	Ensemble de flexible	Flexible, Conj.
9	6109728M91			1	Hose Assy	Ensemble de flexible	Flexible, Conj.
10	358766X91			1	Elbow, 90°	Coude à 90°	Codo, 90°
11		10	➡ Ref. 10	1	Elbow	Coude	Codo
12	835026M1	10		1	O-Ring	Joint torique	Junta de tipo O
13	6107494M91		👁 40003C03.1 1	1	Filter, Oil	Filtre à huile	Filtro de aceite
14	3009491X1	M10 x 20		2	Screw	Vis	Tornillo
15	385362X1	M10		2	Washer	Rondelle	Arandela
16	835013M91			1	Connector Assy	Ensemble connexion	Conexión, Conj.
17		16	➡ Ref. 16	1	Union	Union	Unión
18	835024M1	16		1	O-Ring	Joint torique	Junta de tipo O
19	6109056M91			1	Hose Assy	Ensemble de flexible	Flexible, Conj.
20	6109845M91	1-5/8 - 1-5/16		1	Connector Assy	Ensemble connexion	Conexión, Conj.
21		20	➡ Ref. 20	1	Union	Union	Unión
22		20	➡ Ref. 20	1	O-Ring	Joint torique	Junta de tipo O
23	6108685M91			1	Valve, Check	Clapet anti-retour	Válvula de parada
24	358748X91	1-5/16"		1	Tee	Raccord en T	Te
25	356582X1			1	Cap	Chapeau	Sombbrero
26	6109073M91			1	Tube Assy	Tuyauterie	Conjunto de tubería
27	356577X1			1	Cap	Chapeau	Sombbrero
28	6110446M91		👁 40003C04.1 1	1	Valve, Control	Distributeur	Distribuidor
29	835013M91			1	Connector Assy	Ensemble connexion	Conexión, Conj.
30		29	➡ Ref. 29	1	Union	Union	Unión
31	835024M1	29		1	O-Ring	Joint torique	Junta de tipo O
32	6109619M91			1	Hose Assy	Ensemble de flexible	Flexible, Conj.
33	358764X91			1	Elbow, 90°	Coude à 90°	Codo, 90°
34		33	➡ Ref. 33	1	Elbow	Coude	Codo
35	835025M1	33		1	O-Ring	Joint torique	Junta de tipo O
36	3517847M91			2	Union	Union	Unión
37		36	➡ Ref. 36	1	Union	Union	Unión
38	835024M1	36		1	O-Ring	Joint torique	Junta de tipo O
39	339084X1	M8 x 100		2	Bolt	Boulon	Perno
40	394367X1	M8		2	Nut, Lock	Écrou de blocage	Tuerca de retención



860 880 970 980
 TX860B TX870B
 TX970B

821 822 823 824 825 851 852 853 854 855 921 922 923 931 932

40003C02.1

6199042M3

1

Jan-06

Main Hydraulics
Système Hydraulique
Sistema hidráulico

Hydraulic Lines
Tuyaux Hydrauliques
Circuito hidráulico

Synchro Shuttle
Synchro Shuttle
Synchro Shuttle

C-40004-01.1-A

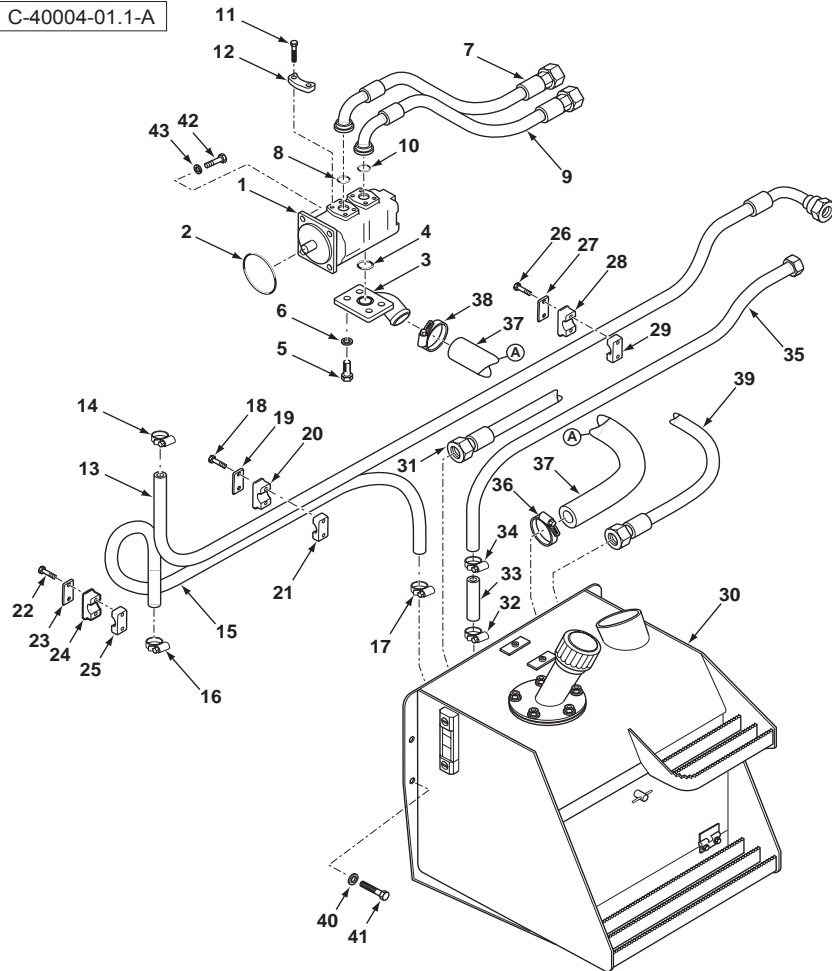

1	6110548M91	(A) 160 LT	1	Pump, Hydraulic	Pompe hydraulique	Bomba hidráulica
2	6109215M1		1	O-Ring	Joint torique	Junta de tipo O
3	6109377M1		1	Block, Elbow	Bloc équerre	Bloque codo
4	359134X1		1	O-Ring	Joint torique	Junta de tipo O
5	1440356X1	M12 x 30	4	Screw	Vis	Tornillo
6	339369X1	M12	4	Washer, Lock	Rondelle de blocage	Arandela de freno
7	6109122M91		1	Hose Assy	Ensemble de flexible	Flexible, Conj.
8	851145M1		1	O-Ring	Joint torique	Junta de tipo O
9	6109122M91		1	Hose Assy	Ensemble de flexible	Flexible, Conj.
10	851145M1		1	O-Ring	Joint torique	Junta de tipo O
11	3009493X1	M10 x 30	8	Bolt	Boulon	Perno
12	3521551M1		4	Bracket, Clamp	Bride de fixation	Brida de fijación
13	6109056M91		1	Hose Assy	Ensemble de flexible	Flexible, Conj.
14	3517410M1		1	Clip	Clip	Clip
15	6109689M1		1	Hose	Flexible	Tubo flexible
16	3517410M1		1	Clip	Clip	Clip
17	3517410M1		1	Clip	Clip	Clip
18	339011X1	M8 x 45	2	Bolt	Boulon	Perno
19	1470376M1		2	Plate	Plaque	Placa
20	6107502M1		2	Clamp	Collier de serrage	Argolla de cierre
21	6107502M1		2	Clamp	Collier de serrage	Argolla de cierre
22	391244X1	M6 x 45	1	Bolt	Boulon	Perno
23	1462583M1		1	Plate	Plaque	Placa
24	1462584M1		1	Clamp	Collier de serrage	Argolla de cierre
25	3520340M3		1	Clamp	Collier de serrage	Argolla de cierre
26	391244X1	M6 x 45	1	Bolt	Boulon	Perno
27	1462583M1		1	Plate	Plaque	Placa
28	1462584M1		1	Clamp	Collier de serrage	Argolla de cierre
29	3520340M3		1	Clamp	Collier de serrage	Argolla de cierre
30	6108959M94	40004C05.1 1	1	Reservoir Assy	Ensemble de réservoir	Depósito, Conj.
31	6109619M91		1	Hose Assy	Ensemble de flexible	Flexible, Conj.
32	3517738M1		1	Clip	Clip	Clip
33	6109065M1		1	Hose	Flexible	Tubo flexible
34	3517738M1		1	Clip	Clip	Clip
35	6109073M91		1	Tube Assy	Tuyauterie	Conjunto de tubería
36	3517414M1		1	Clip	Clip	Clip
37	6109243M1		1	Hose	Flexible	Tubo flexible
38	3517414M1		1	Clip	Clip	Clip
39	6109395M91		1	Hose Assy	Ensemble de flexible	Flexible, Conj.
40	391212X1	M12	4	Washer	Rondelle	Arandela
41	3009505X1	M12 x 25	4	Bolt	Boulon	Perno
42	391334X1	M16 x 50	2	Screw	Vis	Tornillo
43	1441664X1		2	Washer	Rondelle	Arandela



860 880
 TX860B TX870B

817 841 842 843 844 845

40004C01.1

6199042M3

1

Jan-06

Main Hydraulics
Système Hydraulique
Sistema hidráulico

Hydraulic Lines
Tuyaux Hydrauliques
Circuito hidráulico

Synchro Shuttle
Synchro Shuttle
Synchro Shuttle

C-40004-01.1-A

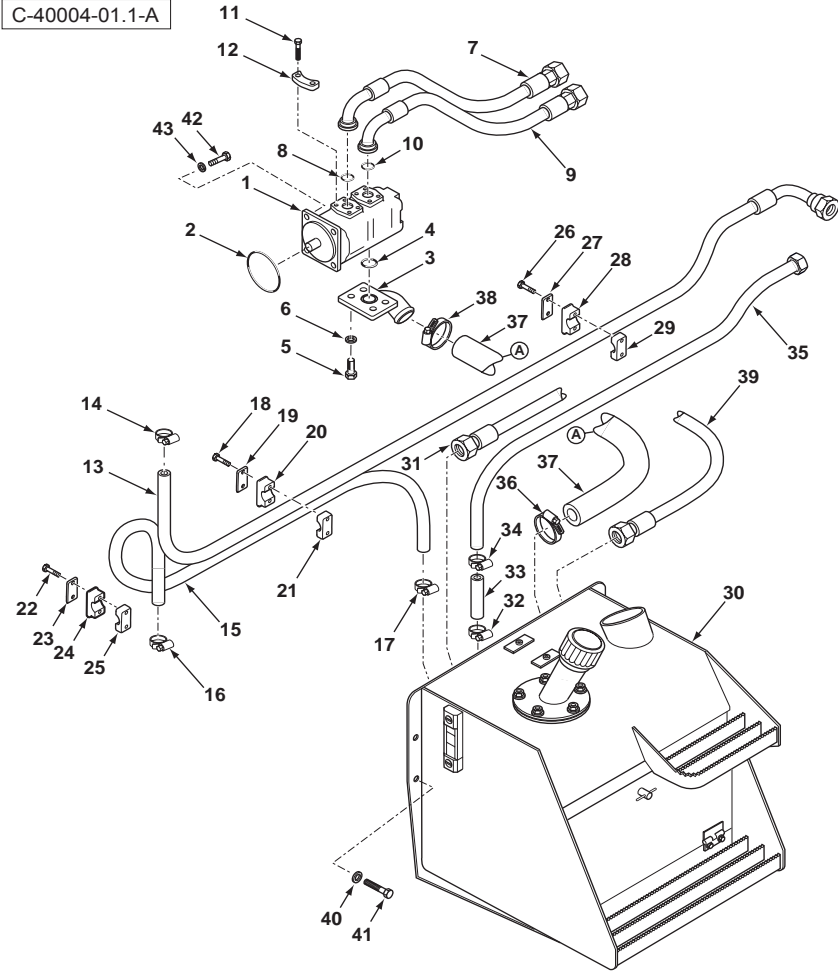

A Details to be advised
Détails à demander
Detalles que deben ser notificados



860 880
TX860B TX870B

817 841 842 843 844 845

40004C01.1

6199042M3

1

Jan-06

Main Hydraulics
Système Hydraulique
Sistema hidráulico

Hydraulic Lines
Tuyaux Hydrauliques
Circuito hidráulico

Synchro Shuttle
Synchro Shuttle
Synchro Shuttle

C-40004-02.1-A

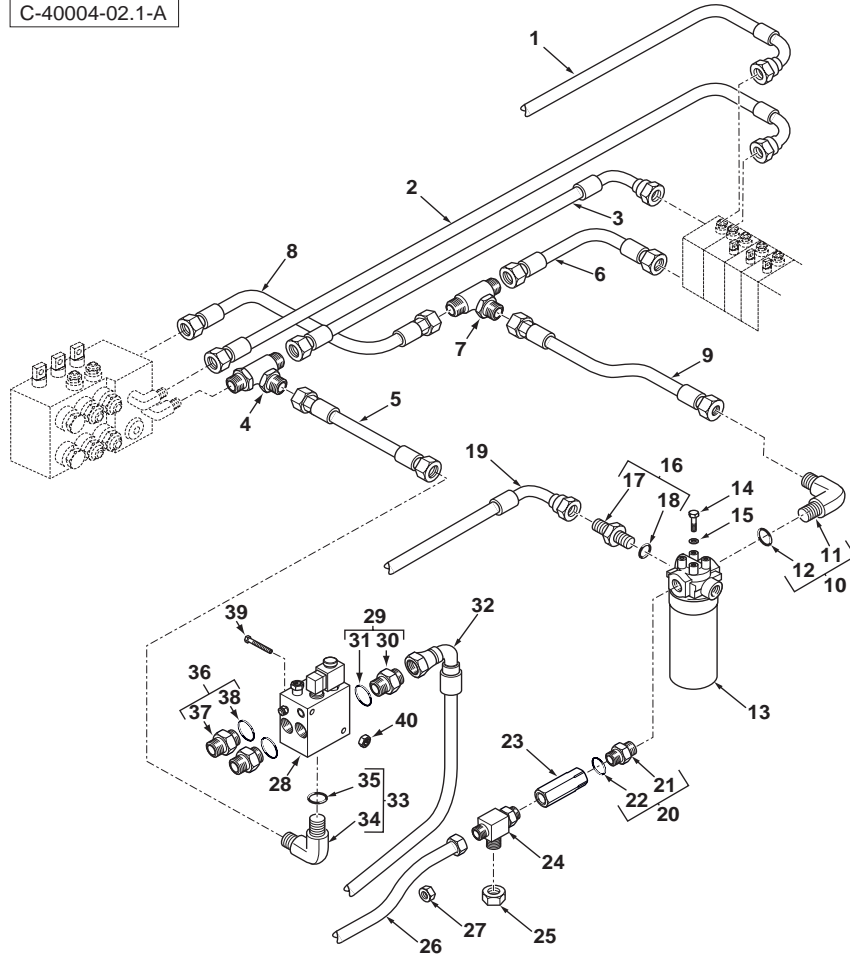

1	6109395M91			1	Hose Assy	Ensemble de flexible	Flexible, Conj.
2	6109448M91			1	Hose Assy	Ensemble de flexible	Flexible, Conj.
3	6109447M91			1	Hose Assy	Ensemble de flexible	Flexible, Conj.
4	371360X1	1-1/16		1	Tee	Raccord en T	Te
5	6108189M91			1	Hose Assy	Ensemble de flexible	Flexible, Conj.
6	6109859M91			1	Tube Assy	Tuyauterie	Conjunto de tubería
7	356564X1	1-5/16"		1	Tee	Raccord en T	Te
8	6109728M91			1	Hose Assy	Ensemble de flexible	Flexible, Conj.
9	6109728M91			1	Hose Assy	Ensemble de flexible	Flexible, Conj.
10	358766X91			1	Elbow, 90°	Coude à 90°	Codo, 90°
11		10	▶ Ref. 10	1	Elbow	Coude	Codo
12	835026M1	10		1	O-Ring	Joint torique	Junta de tipo O
13	6107494M91		● 40004C03.1 1	1	Filter, Oil	Filtere à huile	Filtro de aceite
14	3009491X1	M10 x 20		2	Screw	Vis	Tornillo
15	385362X1	M10		2	Washer	Rondelle	Arandela
16	835013M91			1	Connector Assy	Ensemble connexion	Conexión, Conj.
17		16	▶ Ref. 16	1	Union	Union	Unión
18	835024M1	16		1	O-Ring	Joint torique	Junta de tipo O
19	6109056M91			1	Hose Assy	Ensemble de flexible	Flexible, Conj.
20	6109845M91	1-5/8 - 1-5/16		1	Connector Assy	Ensemble connexion	Conexión, Conj.
21		20	▶ Ref. 20	1	Union	Union	Unión
22		20	▶ Ref. 20	1	O-Ring	Joint torique	Junta de tipo O
23	6108685M91			1	Valve, Check	Clapet anti-retour	Válvula de parada
24	358748X91	1-5/16"		1	Tee	Raccord en T	Te
25	356582X1			1	Cap	Chapeau	Sombbrero
26	6109073M91			1	Tube Assy	Tuyauterie	Conjunto de tubería
27	356577X1			1	Cap	Chapeau	Sombbrero
28	6110446M91		● 40004C04.1 1	1	Valve, Control	Distributeur	Distribuidor
29	835013M91			1	Connector Assy	Ensemble connexion	Conexión, Conj.
30		29	▶ Ref. 29	1	Union	Union	Unión
31	835024M1	29		1	O-Ring	Joint torique	Junta de tipo O
32	6109619M91			1	Hose Assy	Ensemble de flexible	Flexible, Conj.
33	358764X91			1	Elbow, 90°	Coude à 90°	Codo, 90°
34		33	▶ Ref. 33	1	Elbow	Coude	Codo
35	835025M1	33		1	O-Ring	Joint torique	Junta de tipo O
36	3517847M91			2	Union	Union	Unión
37		36	▶ Ref. 36	1	Union	Union	Unión
38	835024M1	36		1	O-Ring	Joint torique	Junta de tipo O
39	339084X1	M8 x 100		2	Bolt	Boulon	Perno
40	394367X1	M8		2	Nut, Lock	Écrou de blocage	Tuerca de retención



860 880
 TX860B TX870B

817 841 842 843 844 845

40004C02.1

6199042M3

1

Jan-06

Main Hydraulics
Système Hydraulique
Sistema hidráulico

Hydraulic Lines
Tuyaux Hydrauliques
Circuito hidráulico

Synchro Shuttle
Synchro Shuttle
Synchro Shuttle

C-40005-01.1-A

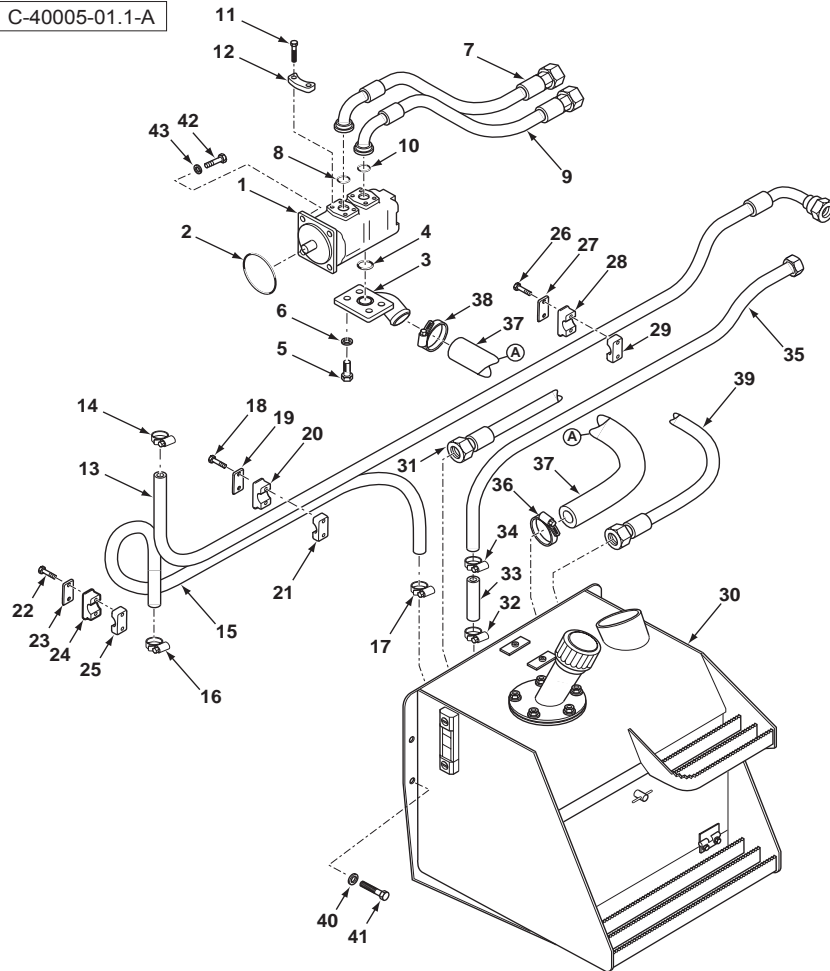

1	6110612M91	(A) 140 LT	1	Pump, Hydraulic	Pompe hydraulique	Bomba hidráulica
2	6109215M1		1	O-Ring	Joint torique	Junta de tipo O
3	6109377M1		1	Block, Elbow	Bloc équerre	Bloque codo
4	359134X1		1	O-Ring	Joint torique	Junta de tipo O
5	1440356X1	M12 x 30	4	Screw	Vis	Tornillo
6	339369X1	M12	4	Washer, Lock	Rondelle de blocage	Arandela de freno
7	6109122M91		1	Hose Assy	Ensemble de flexible	Flexible, Conj.
8	851145M1		1	O-Ring	Joint torique	Junta de tipo O
9	6109122M91		1	Hose Assy	Ensemble de flexible	Flexible, Conj.
10	851145M1		1	O-Ring	Joint torique	Junta de tipo O
11	3009493X1	M10 x 30	8	Bolt	Boulon	Perno
12	3521551M1		4	Bracket, Clamp	Bride de fixation	Brida de fijación
13	6109056M91		1	Hose Assy	Ensemble de flexible	Flexible, Conj.
14	3517410M1		1	Clip	Clip	Clip
15	6109689M1		1	Hose	Flexible	Tubo flexible
16	3517410M1		1	Clip	Clip	Clip
17	3517410M1		1	Clip	Clip	Clip
18	339011X1	M8 x 45	2	Bolt	Boulon	Perno
19	1470376M1		2	Plate	Plaque	Placa
20	6107502M1		2	Clamp	Collier de serrage	Argolla de cierre
21	6107502M1		2	Clamp	Collier de serrage	Argolla de cierre
22	391244X1	M6 x 45	1	Bolt	Boulon	Perno
23	1462583M1		1	Plate	Plaque	Placa
24	1462584M1		1	Clamp	Collier de serrage	Argolla de cierre
25	3520340M3		1	Clamp	Collier de serrage	Argolla de cierre
26	391244X1	M6 x 45	1	Bolt	Boulon	Perno
27	1462583M1		1	Plate	Plaque	Placa
28	1462584M1		1	Clamp	Collier de serrage	Argolla de cierre
29	3520340M3		1	Clamp	Collier de serrage	Argolla de cierre
30	6108959M94	40005C05.1 1	1	Reservoir Assy	Ensemble de réservoir	Depósito, Conj.
31	6109619M91		1	Hose Assy	Ensemble de flexible	Flexible, Conj.
32	3517738M1		1	Clip	Clip	Clip
33	6109065M1		1	Hose	Flexible	Tubo flexible
34	3517738M1		1	Clip	Clip	Clip
35	6109073M91		1	Tube Assy	Tuyauterie	Conjunto de tubería
36	3517414M1		1	Clip	Clip	Clip
37	6109243M1		1	Hose	Flexible	Tubo flexible
38	3517414M1		1	Clip	Clip	Clip
39	6109395M91		1	Hose Assy	Ensemble de flexible	Flexible, Conj.
40	391212X1	M12	4	Washer	Rondelle	Arandela
41	3009505X1	M12 x 25	4	Bolt	Boulon	Perno
42	391334X1	M16 x 50	2	Screw	Vis	Tornillo
43	1441664X1		2	Washer	Rondelle	Arandela



820
TX760B

803 804 807 808 831

40005C01.1

6199042M3

1

Jan-06

Main Hydraulics
Système Hydraulique
Sistema hidráulico

Hydraulic Lines
Tuyaux Hydrauliques
Circuito hidráulico

Synchro Shuttle
Synchro Shuttle
Synchro Shuttle

C-40005-01.1-A

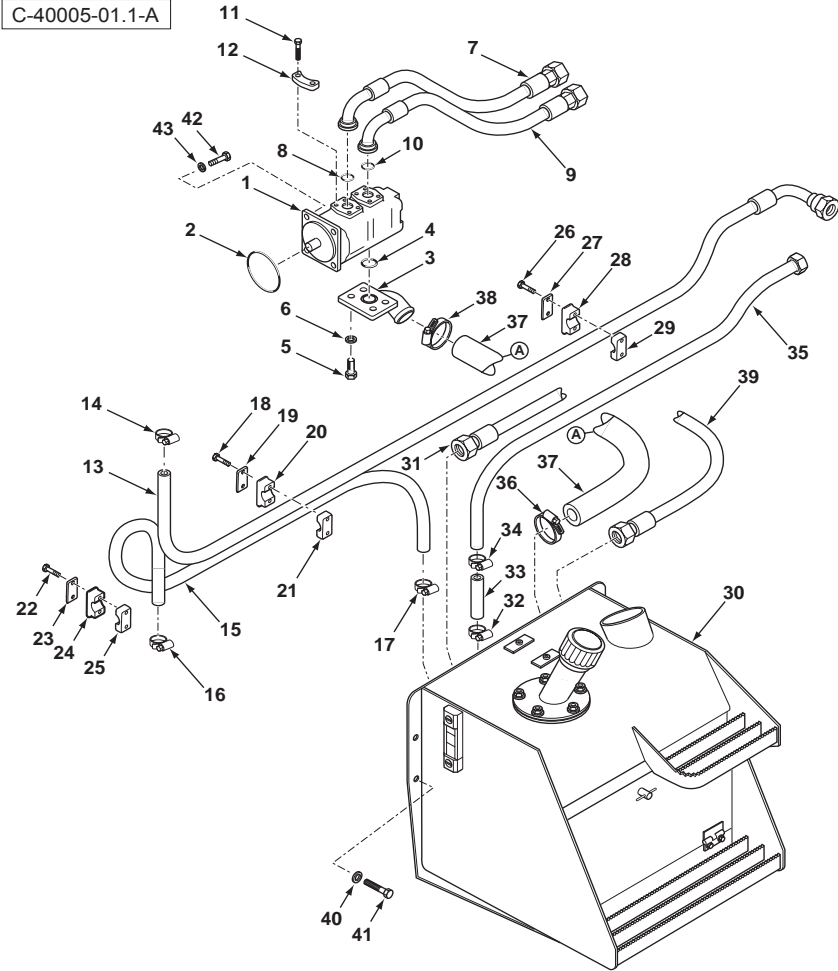

A Details to be advised
Détails à demander
Detalles que deben ser notificados



820
TX760B

803 804 807 808 831

40005C01.1

6199042M3

1

Jan-06

Main Hydraulics
Système Hydraulique
Sistema hidráulico

Hydraulic Lines
Tuyaux Hydrauliques
Circuito hidráulico

Synchro Shuttle
Synchro Shuttle
Synchro Shuttle

C-40005-02.1-A

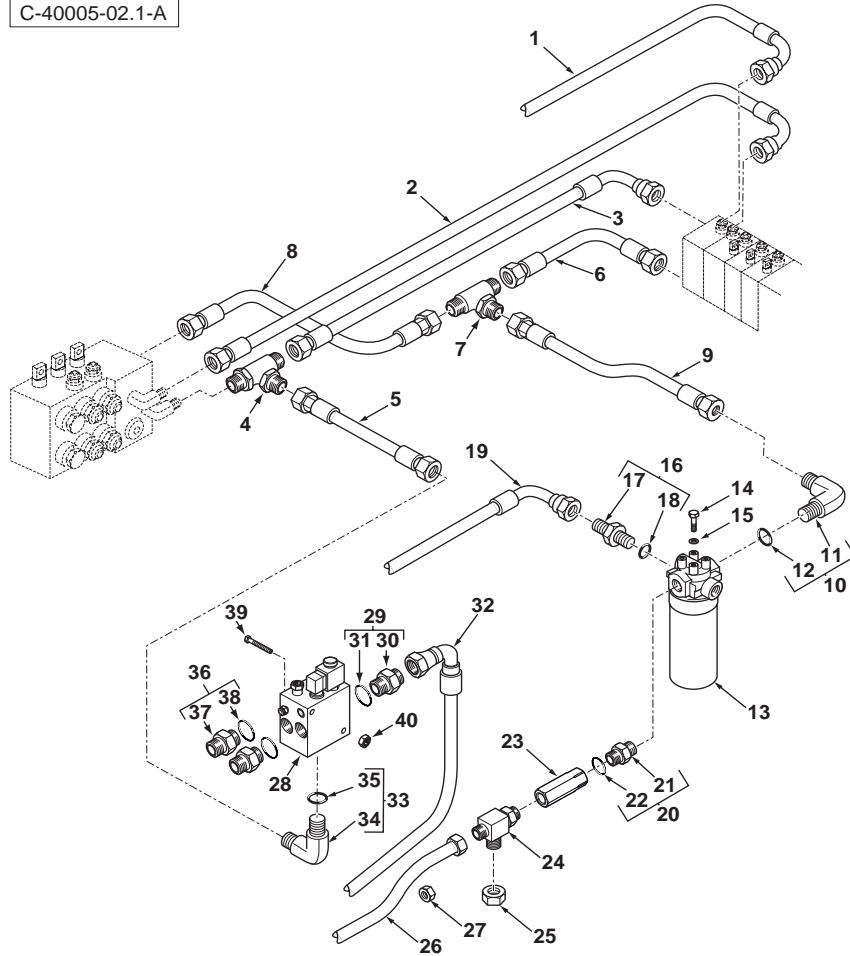

1	6109395M91		1	Hose Assy	Ensemble de flexible	Flexible, Conj.
2	6109448M91		1	Hose Assy	Ensemble de flexible	Flexible, Conj.
3	6109447M91		1	Hose Assy	Ensemble de flexible	Flexible, Conj.
4	371360X1	1-1/16	1	Tee	Raccord en T	Te
5	6108189M91		1	Hose Assy	Ensemble de flexible	Flexible, Conj.
6	6109859M91		1	Tube Assy	Tuyauterie	Conjunto de tubería
7	356564X1	1-5/16"	1	Tee	Raccord en T	Te
8	6109728M91		1	Hose Assy	Ensemble de flexible	Flexible, Conj.
9	6109728M91		1	Hose Assy	Ensemble de flexible	Flexible, Conj.
10	358766X91		1	Elbow, 90°	Coude à 90°	Codo, 90°
11		10	1	Elbow	Coude	Codo
12	835026M1	10	1	O-Ring	Joint torique	Junta de tipo O
13	6107494M91	40005C03.1	1	Filter, Oil	Filter à huile	Filtro de aceite
14	3009491X1	M10 x 20	2	Screw	Vis	Tornillo
15	385362X1	M10	2	Washer	Rondelle	Arandela
16	835013M91		1	Connector Assy	Ensemble connexion	Conexión, Conj.
17		16	1	Union	Union	Unión
18	835024M1	16	1	O-Ring	Joint torique	Junta de tipo O
19	6109056M91		1	Hose Assy	Ensemble de flexible	Flexible, Conj.
20	6109845M91	1-5/8 - 1-5/16	1	Connector Assy	Ensemble connexion	Conexión, Conj.
21		20	1	Union	Union	Unión
22		20	1	O-Ring	Joint torique	Junta de tipo O
23	6108685M91		1	Valve, Check	Clapet anti-retour	Válvula de parada
24	358748X91	1-5/16"	1	Tee	Raccord en T	Te
25	356582X1		1	Cap	Chapeau	Sombbrero
26	6109073M91		1	Tube Assy	Tuyauterie	Conjunto de tubería
27	356577X1		1	Cap	Chapeau	Sombbrero
28	6110446M91	40005C04.1	1	Valve, Control	Distributeur	Distribuidor
29	835013M91		1	Connector Assy	Ensemble connexion	Conexión, Conj.
30		29	1	Union	Union	Unión
31	835024M1	29	1	O-Ring	Joint torique	Junta de tipo O
32	6109619M91		1	Hose Assy	Ensemble de flexible	Flexible, Conj.
33	358764X91		1	Elbow, 90°	Coude à 90°	Codo, 90°
34		33	1	Elbow	Coude	Codo
35	835025M1	33	1	O-Ring	Joint torique	Junta de tipo O
36	3517847M91		2	Union	Union	Unión
37		36	1	Union	Union	Unión
38	835024M1	36	1	O-Ring	Joint torique	Junta de tipo O
39	339084X1	M8 x 100	2	Bolt	Boulon	Perno
40	394367X1	M8	2	Nut, Lock	Écrou de blocage	Tuerca de retención



820
TX760B

803 804 807 808 831

40005C02.1

6199042M3

1

Jan-06

Main Hydraulics
Système Hydraulique
Sistema hidráulico

Oil Filter
Filtre à Huile
Filtro de aceite

Synchro Shuttle
Synchro Shuttle
Synchro Shuttle

C-40001-03.1-A

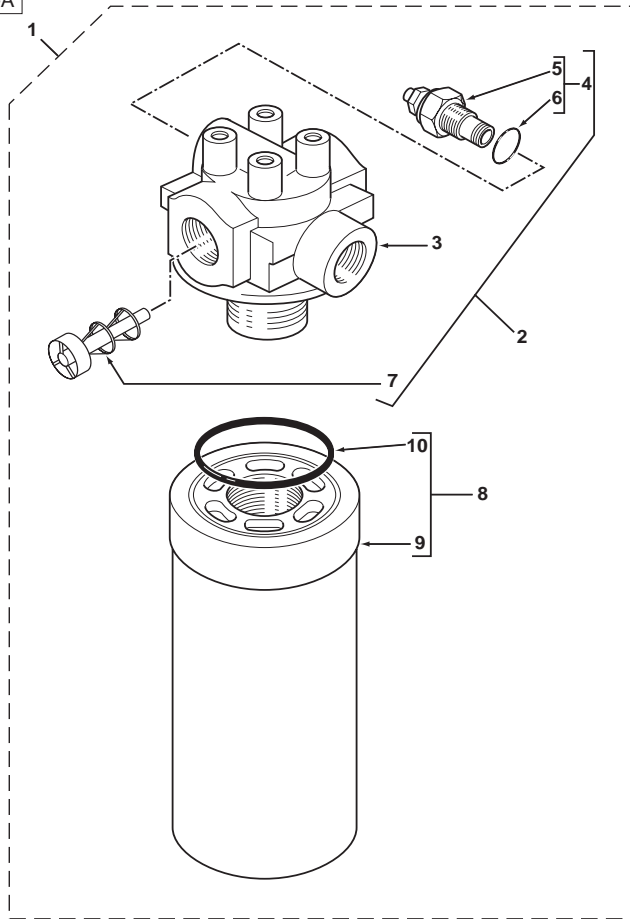

1	6107494M91	40001C02.1 13	1	Filter, Oil	Filtre à huile	Filtro de aceite
2	6107571M91		1	Head, Filter	Tête de filtre	Cabeza de filtro
3		Ref.2	1	Head, Filter	Tête de filtre	Cabeza de filtro
4	6193234M91		1	Switch, Pressure	Pressostat	Presostato
5		Ref.4	1	Switch, Pressure	Pressostat	Presostato
6	3523725M1		1	O-Ring	Joint torique	Junta de tipo O
7		Ref.2	1	Valve, Check	Clapet anti-retour	Válvula de parada
8	6100361M91		1	Element, Filter	Élément filtrant	Elemento filtrante
9		Ref.8	1	Element, Filter	Élément filtrant	Elemento filtrante
10		Ref.8	1	O-Ring	Joint torique	Junta de tipo O



820
TX760B

801 802 803 804 805 806 807 808 831 832 833 834

40001C03.1

6199042M3

1

Jan-06

Main Hydraulics
 Système Hydraulique
 Sistema hidráulico

Oil Filter
 Filtre à Huile
 Filtro de aceite

Synchro Shuttle
 Synchro Shuttle
 Synchro Shuttle

C-40002-03.1-A

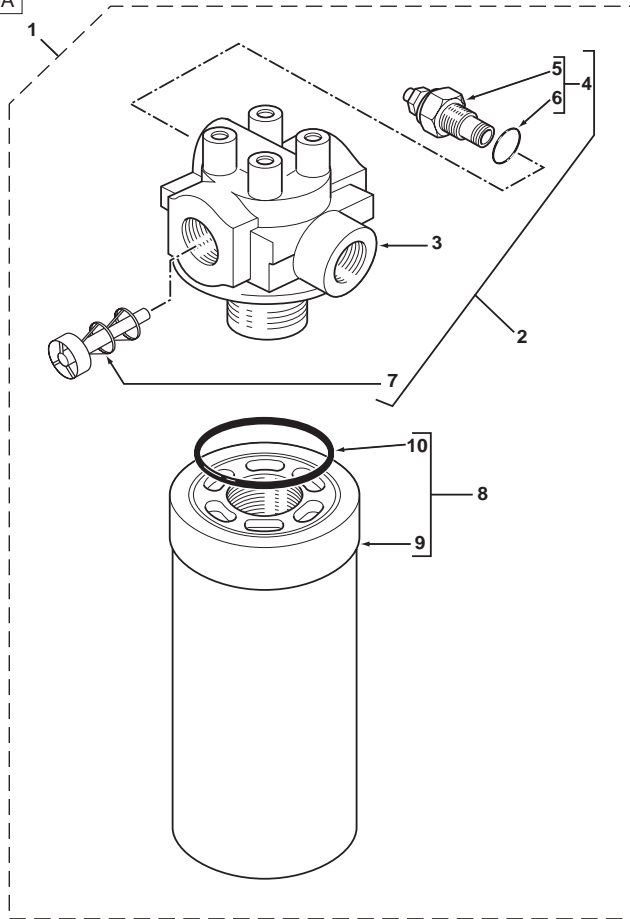

1	6107494M91	40002C02.1 13	1	Filter, Oil	Filtre à huile	Filtro de aceite
2	6107571M91		1	Head, Filter	Tête de filtre	Cabeza de filtro
3			1	Head, Filter	Tête de filtre	Cabeza de filtro
4	6193234M91	Ref.2	1	Switch, Pressure	Pressostat	Presostato
5		Ref.4	1	Switch, Pressure	Pressostat	Presostato
6	3523725M1		1	O-Ring	Joint torique	Junta de tipo O
7		Ref.2	1	Valve, Check	Clapet anti-retour	Válvula de parada
8	6100361M91		1	Element, Filter	Élément filtrant	Elemento filtrante
9		Ref.8	1	Element, Filter	Élément filtrant	Elemento filtrante
10		Ref.8	1	O-Ring	Joint torique	Junta de tipo O



860 880
 TX860B TX870B

809 810 811 812 813 814 815 816 817 841 842 843 844 845

40002C03.1

6199042M3

1

Jan-06

Main Hydraulics
Système Hydraulique
Sistema hidráulico

Oil Filter
Filtre à Huile
Filtro de aceite

Powershift
Powershift
Powershift

C-40003-03.1-A

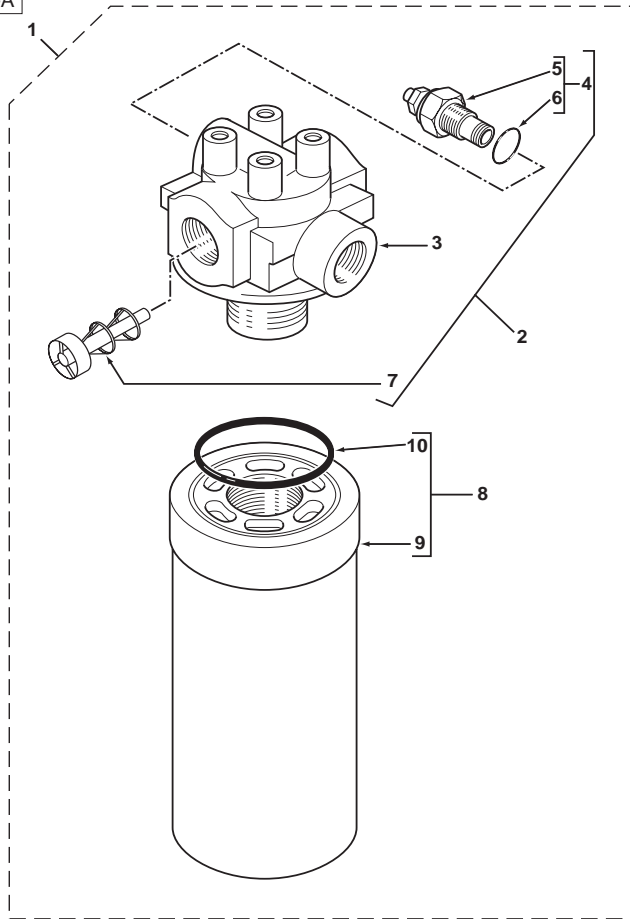

1	6107494M91		40003C02.1 13	1	Filter, Oil	Filtre à huile	Filtro de aceite
2	6107571M91	1		1	Head, Filter	Tête de filtre	Cabeza de filtro
3		2	Ref.2	1	Head, Filter	Tête de filtre	Cabeza de filtro
4	6193234M91	2		1	Switch, Pressure	Pressostat	Presostato
5		4	Ref.4	1	Switch, Pressure	Pressostat	Presostato
6	3523725M1	4		1	O-Ring	Joint torique	Junta de tipo O
7		2	Ref.2	1	Valve, Check	Clapet anti-retour	Válvula de parada
8	6100361M91	1		1	Element, Filter	Élément filtrant	Elemento filtrante
9		8	Ref.8	1	Element, Filter	Élément filtrant	Elemento filtrante
10		8	Ref.8	1	O-Ring	Joint torique	Junta de tipo O



860 880 970 980
TX860B TX870B
TX970B

821 822 823 824 825 851 852 853 854 855 921 922 923 931 932

40003C03.1

6199042M3

1

Jan-06

Main Hydraulics
 Système Hydraulique
 Sistema hidráulico

Oil Filter
 Filtre à Huile
 Filtro de aceite

Synchro Shuttle
 Synchro Shuttle
 Synchro Shuttle

C-40004-03.1-A

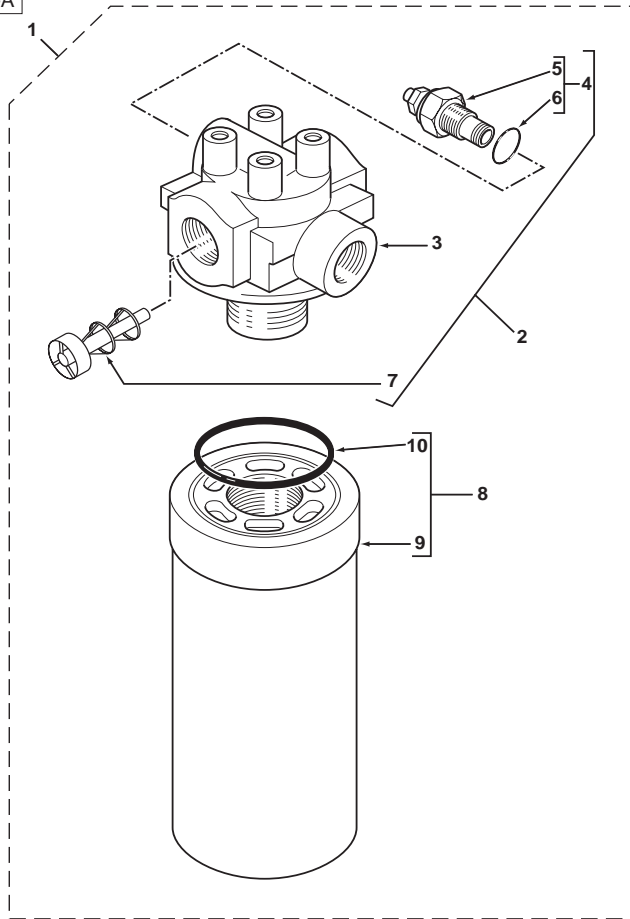

1	6107494M91		40004C02.1 13	1	Filter, Oil	Filtre à huile	Filtro de aceite
2	6107571M91	1		1	Head, Filter	Tête de filtre	Cabeza de filtro
3		2	Ref.2	1	Head, Filter	Tête de filtre	Cabeza de filtro
4	6193234M91	2		1	Switch, Pressure	Pressostat	Presostato
5		4	Ref.4	1	Switch, Pressure	Pressostat	Presostato
6	3523725M1	4		1	O-Ring	Joint torique	Junta de tipo O
7		2	Ref.2	1	Valve, Check	Clapet anti-retour	Válvula de parada
8	6100361M91	1		1	Element, Filter	Élément filtrant	Elemento filtrante
9		8	Ref.8	1	Element, Filter	Élément filtrant	Elemento filtrante
10		8	Ref.8	1	O-Ring	Joint torique	Junta de tipo O



860 880
 TX860B TX870B

817 841 842 843 844 845

40004C03.1

6199042M3

1

Jan-06

Main Hydraulics
 Système Hydraulique
 Sistema hidráulico

Oil Filter
 Filtre à Huile
 Filtro de aceite

Synchro Shuttle
 Synchro Shuttle
 Synchro Shuttle

C-40005-03.1-A

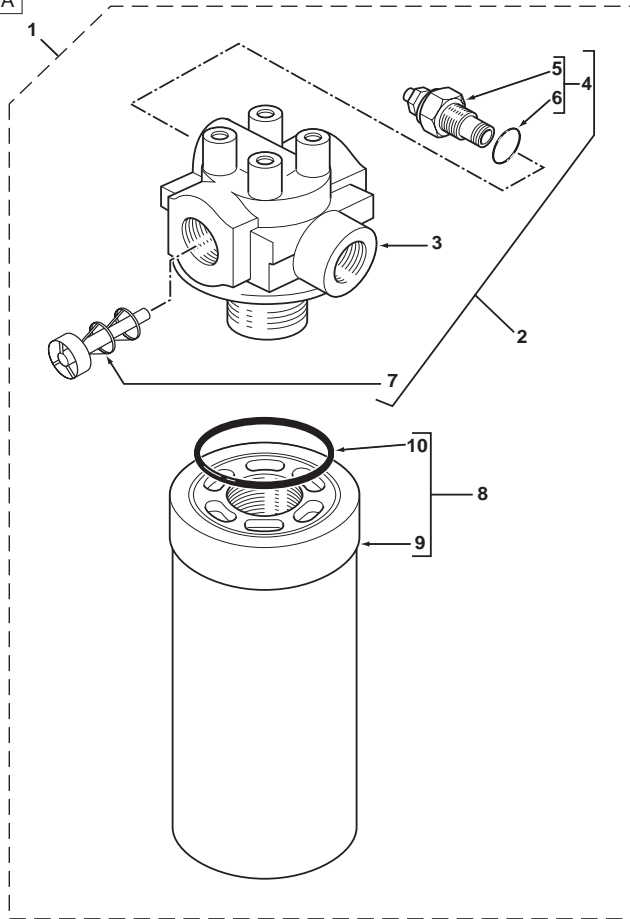

1	6107494M91	40005C02.1 13	1	Filter, Oil	Filtre à huile	Filtro de aceite
2	6107571M91		1	Head, Filter	Tête de filtre	Cabeza de filtro
3		Ref.2	1	Head, Filter	Tête de filtre	Cabeza de filtro
4	6193234M91		1	Switch, Pressure	Pressostat	Presostato
5		Ref.4	1	Switch, Pressure	Pressostat	Presostato
6	3523725M1		1	O-Ring	Joint torique	Junta de tipo O
7		Ref.2	1	Valve, Check	Clapet anti-retour	Válvula de parada
8	6100361M91		1	Element, Filter	Élément filtrant	Elemento filtrante
9		Ref.8	1	Element, Filter	Élément filtrant	Elemento filtrante
10		Ref.8	1	O-Ring	Joint torique	Junta de tipo O



820
 TX760B

803 804 807 808 831

40005C03.1

6199042M3

1

Jan-06

Main Hydraulics
Système Hydraulique
Sistema hidráulico

Solenoid Valve
Électrovanne
Electroválvula

Synchro Shuttle
Synchro Shuttle
Synchro Shuttle

C-40001-04.1-A

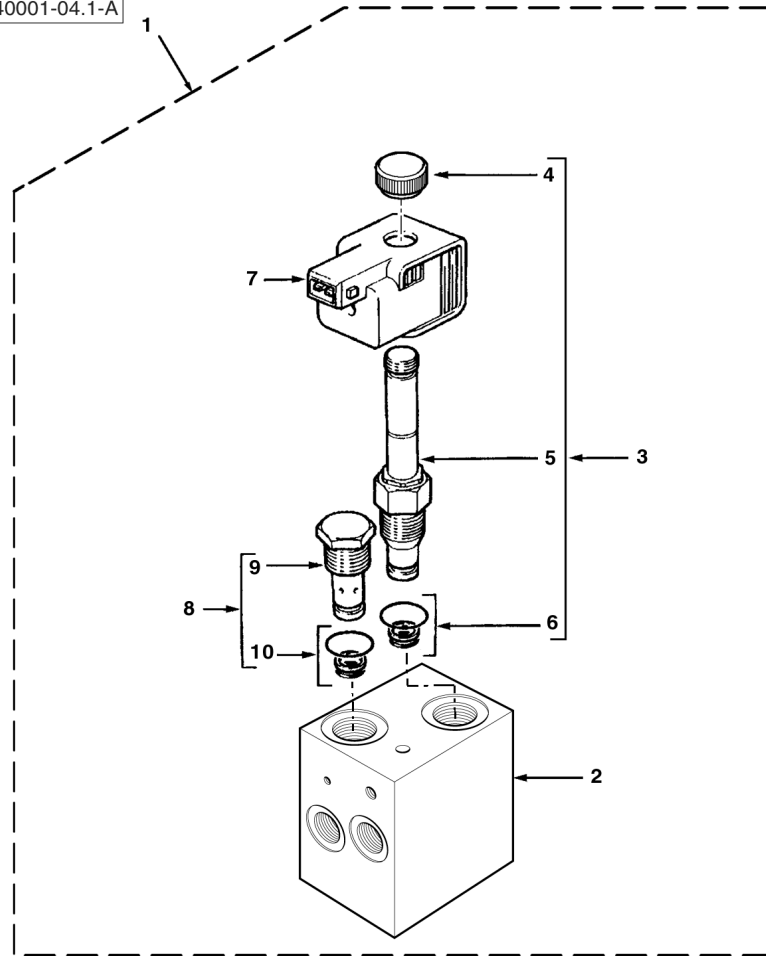

1	6110446M91		40001C02.1 28	1	Valve, Control	Distributeur	Distribuidor
2		1	Ref.1	1	Body	Corps	Cuerpo
3	6193714M1	1		1	Solenoid Assy	Ensemble de solénoïde	Solenoides, Conj.
4		3	Ref.3	1	Nut	Écrou	Tuerca
5		3	Ref.3	1	Spool	Tiroir	Cajoncillo
6	6193715M91	3		1	Kit, Seal	Pochette de joints	Juego de juntas
7	6193716M1	1		1	Coil	Bobine	Bobina
8	6193712M1	1		1	Valve, Relief	Soupape, décharge	Válvula, Descarga
9		8	Ref.8	1	Valve	Soupape	Válvula
10	6193713M91	8		1	Kit, Seal	Pochette de joints	Juego de juntas



820
TX760B

801 802 803 804 805 806 807 808 831 832 833 834

40001C04.1

6199042M3

1

Jan-06

Main Hydraulics
 Système Hydraulique
 Sistema hidráulico

Solenoid Valve
 Électrovanne
 Electroválvula

Synchro Shuttle
 Synchro Shuttle
 Synchro Shuttle

C-40002-04.1-A

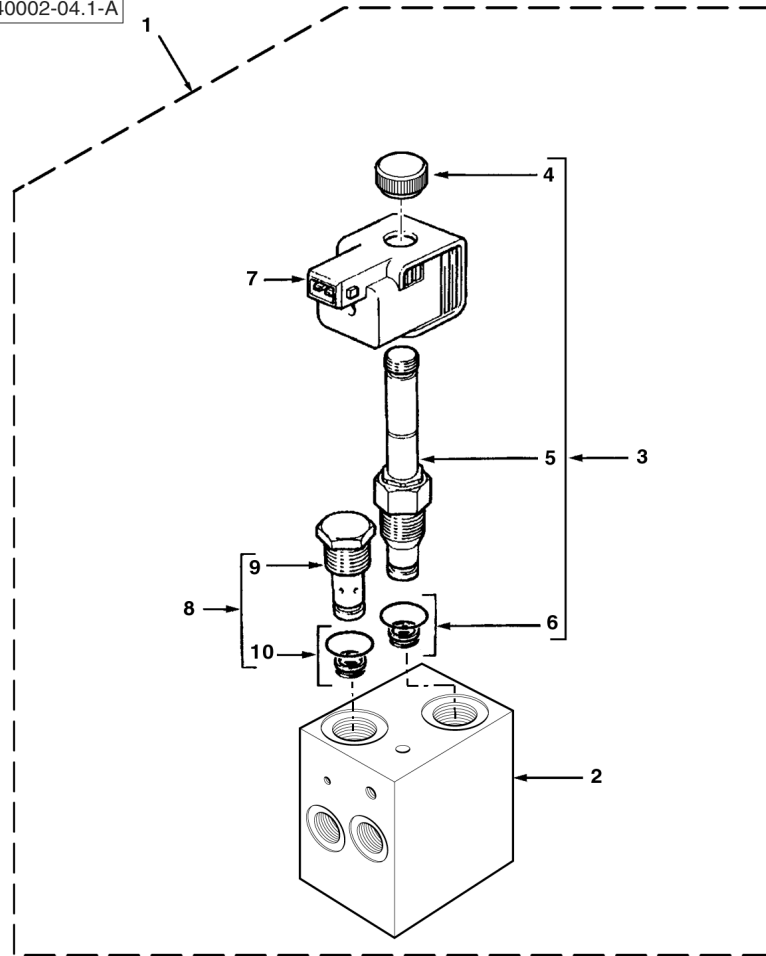

1	6110446M91		40002C02.1 28	1	Valve, Control	Distributeur	Distribuidor
2		1	Ref.1	1	Body	Corps	Cuerpo
3	6193714M1	1		1	Solenoid Assy	Ensemble de solénoïde	Solenoides, Conj.
4		3	Ref.3	1	Nut	Écrou	Tuerca
5		3	Ref.3	1	Spool	Tiroir	Cajoncillo
6	6193715M91	3		1	Kit, Seal	Pochette de joints	Juego de juntas
7	6193716M1	1		1	Coil	Bobine	Bobina
8	6193712M1	1		1	Valve, Relief	Soupape, décharge	Válvula, Descarga
9		8	Ref.8	1	Valve	Soupape	Válvula
10	6193713M91	8		1	Kit, Seal	Pochette de joints	Juego de juntas



860 880
 TX860B TX870B

809 810 811 812 813 814 815 816 817 841 842 843 844 845

40002C04.1

6199042M3

1

Jan-06

Main Hydraulics
Système Hydraulique
Sistema hidráulico

Solenoid Valve
Électrovanne
Electroválvula

Powershift
Powershift
Powershift

C-40003-04.1-A

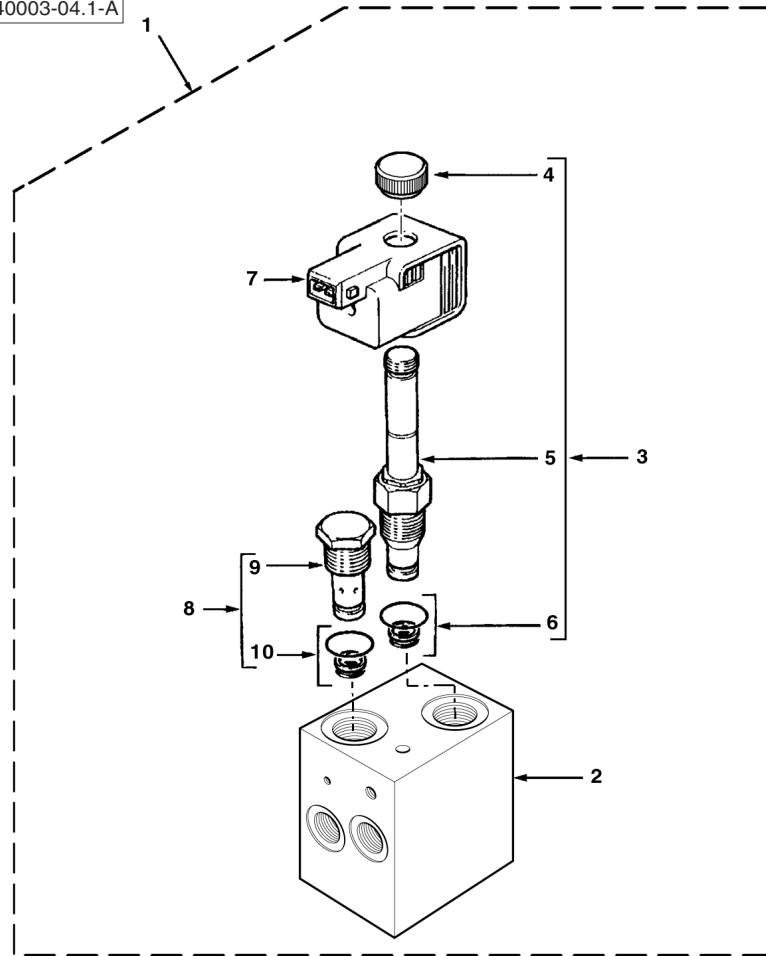

1	6110446M91		40003C02.1 28	1	Valve, Control	Distributeur	Distribuidor
2		1	Ref.1	1	Body	Corps	Cuerpo
3	6193714M1	1		1	Solenoid Assy	Ensemble de solénoïde	Solenoide, Conj.
4		3	Ref.3	1	Nut	Écrou	Tuerca
5		3	Ref.3	1	Spool	Tiroir	Cajoncillo
6	6193715M91	3		1	Kit, Seal	Pochette de joints	Juego de juntas
7	6193716M1	1		1	Coil	Bobine	Bobina
8	6193712M1	1		1	Valve, Relief	Soupape, décharge	Válvula, Descarga
9		8	Ref.8	1	Valve	Soupape	Válvula
10	6193713M91	8		1	Kit, Seal	Pochette de joints	Juego de juntas



860 880 970 980
TX860B TX870B
TX970B

821 822 823 824 825 851 852 853 854 855 921 922 923 931 932

40003C04.1

6199042M3

1

Jan-06

Main Hydraulics
 Système Hydraulique
 Sistema hidráulico

Solenoid Valve
 Électrovanne
 Electroválvula

Synchro Shuttle
 Synchro Shuttle
 Synchro Shuttle

C-40004-04.1-A

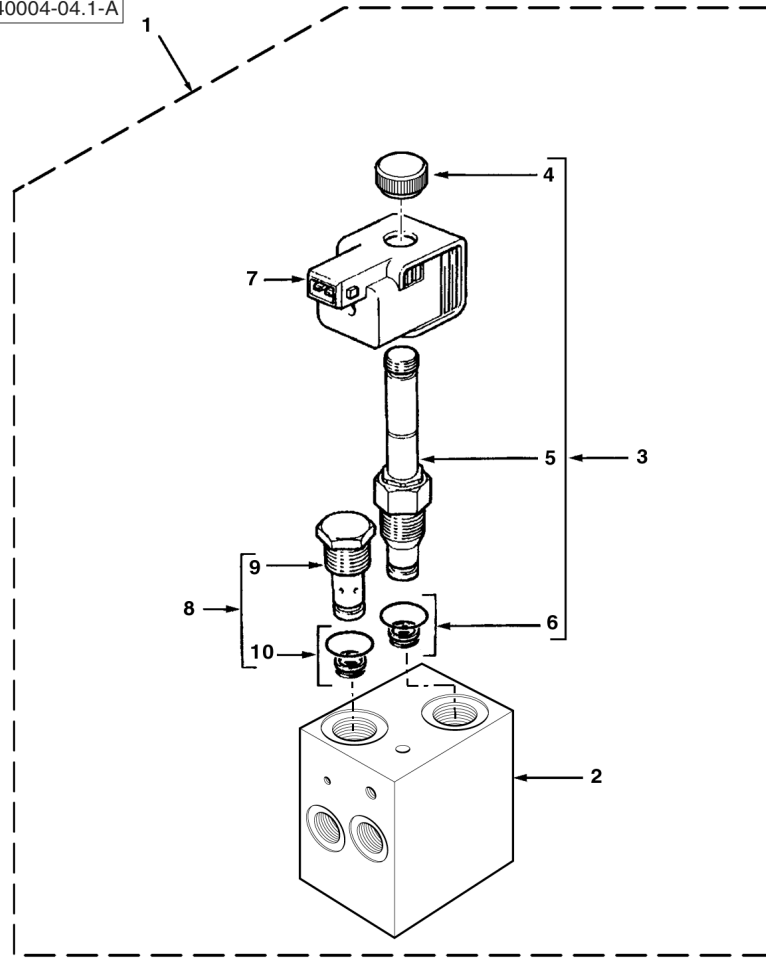

1	6110446M91		40004C02.1 28	1	Valve, Control	Distributeur	Distribuidor
2		1	Ref.1	1	Body	Corps	Cuerpo
3	6193714M1	1		1	Solenoid Assy	Ensemble de solénoïde	Solenoide, Conj.
4		3	Ref.3	1	Nut	Écrou	Tuerca
5		3	Ref.3	1	Spool	Tiroir	Cajoncillo
6	6193715M91	3		1	Kit, Seal	Pochette de joints	Juego de juntas
7	6193716M1	1		1	Coil	Bobine	Bobina
8	6193712M1	1		1	Valve, Relief	Soupape, décharge	Válvula, Descarga
9		8	Ref.8	1	Valve	Soupape	Válvula
10	6193713M91	8		1	Kit, Seal	Pochette de joints	Juego de juntas



860 880
 TX860B TX870B

817 841 842 843 844 845

40004C04.1

6199042M3

1

Jan-06

Main Hydraulics
Système Hydraulique
Sistema hidráulico

Solenoid Valve
Électrovanne
Electroválvula

Synchro Shuttle
Synchro Shuttle
Synchro Shuttle

C-40005-04.1-A

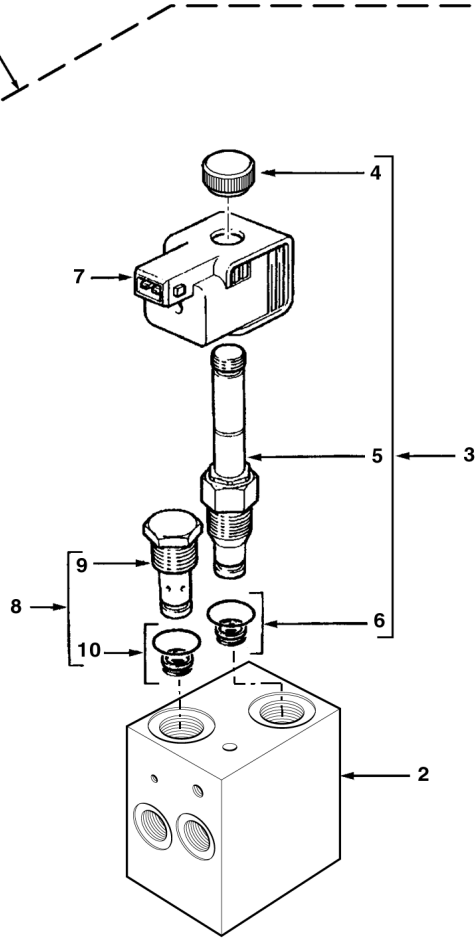

1	6110446M91		40005C02.1 28	1	Valve, Control	Distributeur	Distribuidor
2		1	Ref.1	1	Body	Corps	Cuerpo
3	6193714M1	1		1	Solenoid Assy	Ensemble de solénoïde	Solenoides, Conj.
4		3	Ref.3	1	Nut	Écrou	Tuerca
5		3	Ref.3	1	Spool	Tiroir	Cajoncillo
6	6193715M91	3		1	Kit, Seal	Pochette de joints	Juego de juntas
7	6193716M1	1		1	Coil	Bobine	Bobina
8	6193712M1	1		1	Valve, Relief	Soupape, décharge	Válvula, Descarga
9		8	Ref.8	1	Valve	Soupape	Válvula
10	6193713M91	8		1	Kit, Seal	Pochette de joints	Juego de juntas



820
TX760B

803 804 807 808 831

40005C04.1

6199042M3

1

Jan-06

Main Hydraulics
Système Hydraulique
Sistema hidráulico

Tandem Pump
Pompe Tandem
Bombas en serie

Synchro Shuttle
Synchro Shuttle
Synchro Shuttle

C-40001-06.1-A

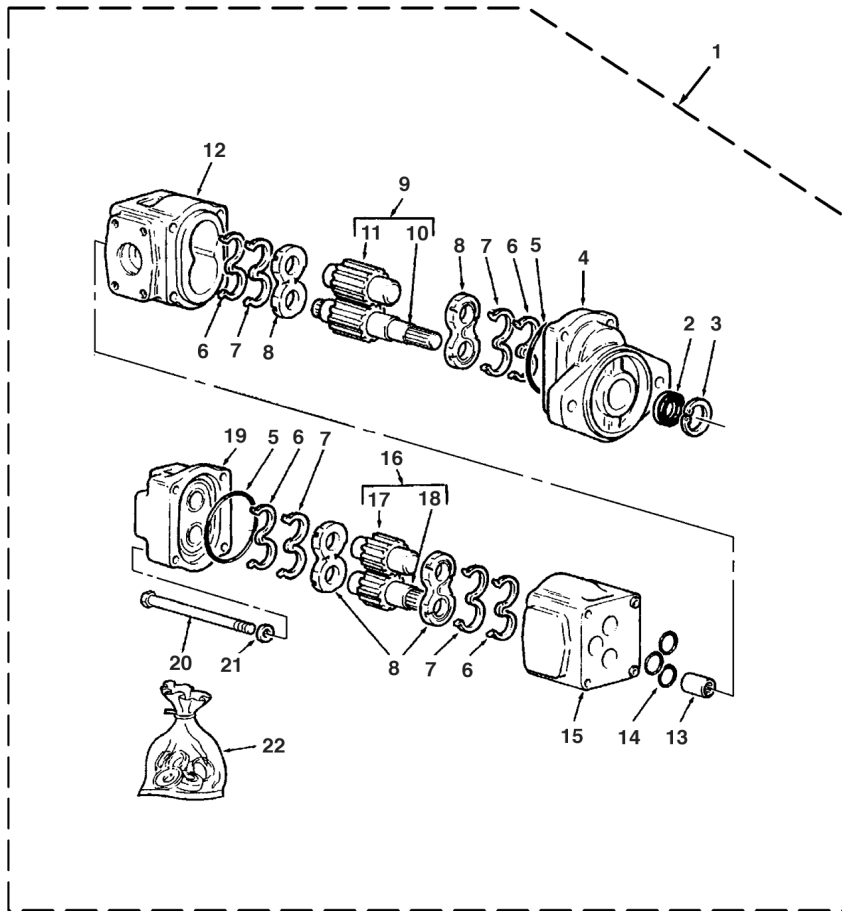

1	6109163M91	40001C01.1 140 LT	1	Pump, Hydraulic	Pompe hydraulique	Bomba hidráulica
2		1 (A)	1	Seal	Joint	Junta
3		1 (A)	1	Ring, Snap	Anneau d'arrêt	Anillo de resorte
4		1 (A) Ref. 1	1	Flange	Flasque	Brida de unión
5		1 (A)	2	O-Ring	Joint torique	Junta de tipo O
6		1 (A)	4	Ring, Sealing	Bague d'étanchéité	Anillo, Estanqueidad
7		1 (A)	4	Ring, Backup	Contre-joint	ContraJunta
8		1 (A) Ref. 1	4	Support	Support	Soporte
9		1 (A) Ref. 1	1	Gear, Set	Jeu de pignons	Juego de piñones
10		9 (A) Ref. 9	1	Gear	Pignon	Piñón
11		9 (A) Ref. 9	1	Gear	Pignon	Piñón
12		1 (A) Ref. 1	1	Body	Corps	Cuerpo
13		1 (A) Ref. 1	1	Coupling	Accouplement	Acoplamiento
14		1 (A)	3	O-Ring	Joint torique	Junta de tipo O
15		1 (A) Ref. 1	1	Body	Corps	Cuerpo
16		1 (A) Ref. 1	1	Gear, Set	Jeu de pignons	Juego de piñones
17		16 (A) Ref. 16	1	Gear	Pignon	Piñón
18		16 (A) Ref. 16	1	Gear	Pignon	Piñón
19		1 (A) Ref. 1	1	Cover, Rear	Couvercle arrière	Tapa trasera
20	6190244M1	1 M12 x 218	4	Screw	Vis	Tornillo
21	390724X1	1	4	Washer	Rondelle	Arandela
22	3523490M91	1 (B)	X	Kit, Seal	Pochette de joints	Juego de juntas

A Included in kit marked (B)
Inclus dans jeu marqué (B)
Incluido en juego marcado (B)

B Contains items marked (A)
Comprend les pièces marquées (A)
Incluye las piezas marcadas (A)



820
TX760B

801 802 803 804 805 806 807 808 831 832 833 834

40001C06.1

6199042M3

1

Jan-06

Main Hydraulics
Système Hydraulique
Sistema hidráulico

Tandem Pump
Pompe Tandem
Bombas en serie

Synchro Shuttle
Synchro Shuttle
Synchro Shuttle

C-40002-06.1-A

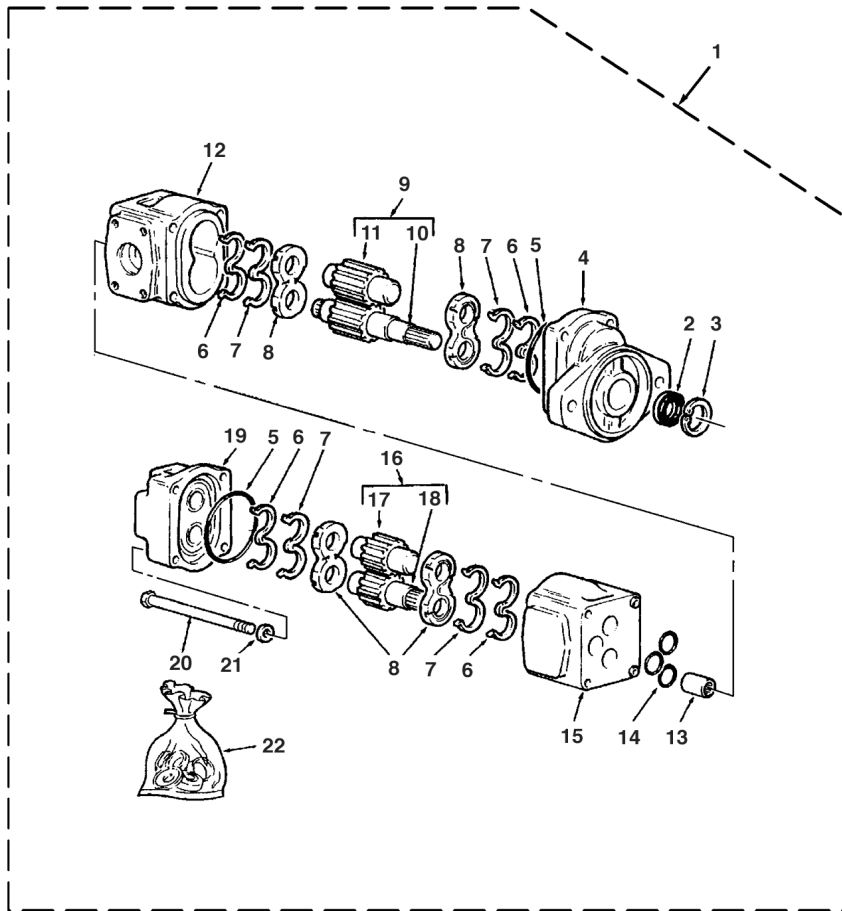

1	6109162M91	40002C01.1 160 LT	1	Pump, Hydraulic	Pompe hydraulique	Bomba hidráulica
2		1 (A)	1	Seal	Joint	Junta
3		1 (A)	1	Ring, Snap	Anneau d'arrêt	Anillo de resorte
4		1 Ref. 1	1	Flange	Flasque	Brida de unión
5		1 (A)	2	O-Ring	Joint torique	Junta de tipo O
6		1 (A)	4	Ring, Sealing	Bague d'étanchéité	Anillo, Estanqueidad
7		1 (A)	4	Ring, Backup	Contre-joint	Contrajunta
8		1 Ref. 1	4	Support	Support	Soporte
9		1 Ref. 1	1	Gear, Set	Jeu de pignons	Juego de piñones
10		9 Ref. 1	1	Gear	Pignon	Piñón
11		9 Ref. 1	1	Gear	Pignon	Piñón
12		1 Ref. 1	1	Body	Corps	Cuerpo
13		1 Ref. 1	1	Coupling	Accouplement	Acoplamiento
14		1 (A)	3	O-Ring	Joint torique	Junta de tipo O
15		1 Ref. 1	1	Body	Corps	Cuerpo
16		1 Ref. 1	1	Gear, Set	Jeu de pignons	Juego de piñones
17		16 Ref. 1	1	Gear	Pignon	Piñón
18		16 Ref. 1	1	Gear	Pignon	Piñón
19		1 Ref. 1	1	Cover, Rear	Couvercle arrière	Tapa trasera
20	6190756M1	1 M12 x 226	4	Screw	Vis	Tornillo
21	390724X1	1	4	Washer	Rondelle	Arandela
22	3523490M91	1 (B)	X	Kit, Seal	Pochette de joints	Juego de juntas

A Included in kit marked (B)
Inclus dans jeu marqué (B)
Incluido en juego marcado (B)

B Contains items marked (A)
Comprend les pièces marquées (A)
Incluye las piezas marcadas (A)



860 880
TX860B TX870B

809 810 811 812 813 814 815 816 817 841 842 843 844 845

40002C06.1

6199042M3

1

Jan-06

Main Hydraulics
Système Hydraulique
Sistema hidráulico

Tandem Pump
Pompe Tandem
Bombas en serie

Powershift
Powershift
Powershift

C-40003-06.1-A

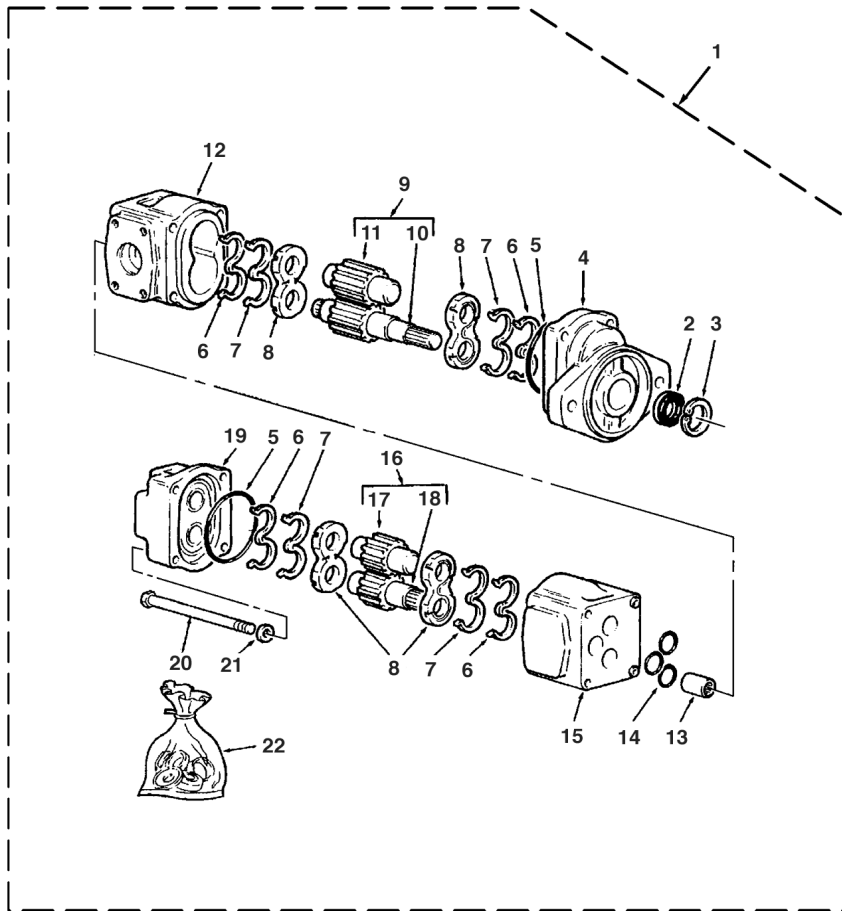

1	6109162M91	40003C01.1 160 LT	1	Pump, Hydraulic	Pompe hydraulique	Bomba hidráulica
2		1 (A)	1	Seal	Joint	Junta
3		1 (A)	1	Ring, Snap	Anneau d'arrêt	Anillo de resorte
4		1 (A) Ref. 1	1	Flange	Flasque	Brida de unión
5		1 (A)	2	O-Ring	Joint torique	Junta de tipo O
6		1 (A)	4	Ring, Sealing	Bague d'étanchéité	Anillo, Estanqueidad
7		1 (A)	4	Ring, Backup	Contre-joint	ContraJunta
8		1 (A) Ref. 1	4	Support	Support	Soporte
9		1 (A) Ref. 1	1	Gear, Set	Jeu de pignons	Juego de piñones
10		9 (A) Ref. 1	1	Gear	Pignon	Piñón
11		9 (A) Ref. 1	1	Gear	Pignon	Piñón
12		1 (A) Ref. 1	1	Body	Corps	Cuerpo
13		1 (A) Ref. 1	1	Coupling	Accouplement	Acoplamiento
14		1 (A)	3	O-Ring	Joint torique	Junta de tipo O
15		1 (A) Ref. 1	1	Body	Corps	Cuerpo
16		1 (A) Ref. 1	1	Gear, Set	Jeu de pignons	Juego de piñones
17		16 (A) Ref. 1	1	Gear	Pignon	Piñón
18		16 (A) Ref. 1	1	Gear	Pignon	Piñón
19		1 (A) Ref. 1	1	Cover, Rear	Couvercle arrière	Tapa trasera
20	6190756M1	1 M12 x 226	4	Screw	Vis	Tornillo
21	390724X1	1	4	Washer	Rondelle	Arandela
22	3523490M91	1 (B)	X	Kit, Seal	Pochette de joints	Juego de juntas

A Included in kit marked (B)
Inclus dans jeu marqué (B)
Incluido en juego marcado (B)

B Contains items marked (A)
Comprend les pièces marquées (A)
Incluye las piezas marcadas (A)



860 880 970 980
TX860B TX870B
TX970B

821 822 823 824 825 851 852 853 854 855 921 922 923 931 932

40003C06.1

6199042M3

1

Jan-06

G - Loader • Chargeuse • Cargadora

Hose Burst Kit.....	98038C01.1	Coffret de Éclatement de Tuyau	Juego de rotura de tubo flexible
Hose Burst Kit.....	98038C02.1	Coffret de Éclatement de Tuyau	Juego de rotura de tubo flexible
Loader - Arms.....	65001C01.1	Chargeur - Bras	Cargadora - Brazo
Loader - Arms.....	65002C01.1	Chargeur - Bras	Cargadora - Brazo
Loader - Links.....	65001C02.1	Chargeur - Articulation	Cargadora - Articulación
Loader - Links.....	65002C02.1	Chargeur - Articulation	Cargadora - Articulación
Loader - Return To Dig.....	65001C03.1	Chargeur - Retour Pelle	Cargadora - Retorno a excavación
Loader - Return To Dig.....	65001C04.1	Chargeur - Retour Pelle	Cargadora - Retorno a excavación
Loader - Return To Dig.....	65002C03.1	Chargeur - Retour Pelle	Cargadora - Retorno a excavación
Loader - Return To Dig.....	65002C04.1	Chargeur - Retour Pelle	Cargadora - Retorno a excavación
Loader - Safety Strut.....	65001C05.1	Chargeur - Béquille de Sécurité	Cargadora - Sostén de seguridad
Loader - Safety Strut.....	65002C05.1	Chargeur - Béquille de Sécurité	Cargadora - Sostén de seguridad
Loader Controls.....	68003C01.1	Commandes de Chargeur	Mandos de cargadora
Loader Controls.....	68003C02.1	Commandes de Chargeur	Mandos de cargadora
Loader Controls.....	68003C03.1	Commandes de Chargeur	Mandos de cargadora
Loader Controls.....	68004C01.1	Commandes de Chargeur	Mandos de cargadora
Loader Controls.....	68004C02.1	Commandes de Chargeur	Mandos de cargadora
Loader Controls.....	68004C03.1	Commandes de Chargeur	Mandos de cargadora
Loader Controls.....	68006C01.1	Commandes de Chargeur	Mandos de cargadora
Loader Controls.....	68006C02.1	Commandes de Chargeur	Mandos de cargadora
Loader Controls.....	68006C03.1	Commandes de Chargeur	Mandos de cargadora
Loader Controls.....	68007C01.1	Commandes de Chargeur	Mandos de cargadora
Loader Controls.....	68007C02.1	Commandes de Chargeur	Mandos de cargadora
Loader Controls.....	68007C03.1	Commandes de Chargeur	Mandos de cargadora
Loader Controls - Control Valve.....	68008C03.1	Commandes de Chargeur - Distributeur	Mandos de cargadora - Distribuidor
Loader Controls - Control Valve.....	68009C03.1	Commandes de Chargeur - Distributeur	Mandos de cargadora - Distribuidor
Loader Controls - Hydraulic Valve.....	68003C04.1	Commandes de Chargeur - Distributeur de Commande Hydraulique	Mandos de cargadora - Distribuidor de mando hidráulico
Loader Controls - Hydraulic Valve.....	68003C05.1	Commandes de Chargeur - Distributeur de Commande Hydraulique	Mandos de cargadora - Distribuidor de mando hidráulico
Loader Controls - Hydraulic Valve.....	68003C06.1	Commandes de Chargeur - Distributeur de Commande Hydraulique	Mandos de cargadora - Distribuidor de mando hidráulico
Loader Controls - Hydraulic Valve.....	68003C07.1	Commandes de Chargeur - Distributeur de Commande Hydraulique	Mandos de cargadora - Distribuidor de mando hidráulico
Loader Controls - Hydraulic Valve.....	68003C08.1	Commandes de Chargeur - Distributeur de Commande Hydraulique	Mandos de cargadora - Distribuidor de mando hidráulico
Loader Controls - Hydraulic Valve.....	68004C04.1	Commandes de Chargeur - Distributeur de Commande Hydraulique	Mandos de cargadora - Distribuidor de mando hidráulico
Loader Controls - Hydraulic Valve.....	68004C05.1	Commandes de Chargeur - Distributeur de Commande Hydraulique	Mandos de cargadora - Distribuidor de mando hidráulico
Loader Controls - Hydraulic Valve.....	68004C06.1	Commandes de Chargeur - Distributeur de Commande Hydraulique	Mandos de cargadora - Distribuidor de mando hidráulico
Loader Controls - Hydraulic Valve.....	68004C07.1	Commandes de Chargeur - Distributeur de Commande Hydraulique	Mandos de cargadora - Distribuidor de mando hidráulico
Loader Controls - Hydraulic Valve.....	68004C08.1	Commandes de Chargeur - Distributeur de Commande Hydraulique	Mandos de cargadora - Distribuidor de mando hidráulico
Loader Controls - Hydraulic Valve.....	68006C04.1	Commandes de Chargeur - Distributeur de Commande Hydraulique	Mandos de cargadora - Distribuidor de mando hidráulico
Loader Controls - Hydraulic Valve.....	68006C05.1	Commandes de Chargeur - Distributeur de Commande Hydraulique	Mandos de cargadora - Distribuidor de mando hidráulico



Hose Burst Kit
Coffret de Éclatement de Tuyau
Juego de rotura de tubo flexible

Loader Arm Cylinder
Vérin de Bras Chargeur
Gato de brazo cargador

C-98038-01.1-A

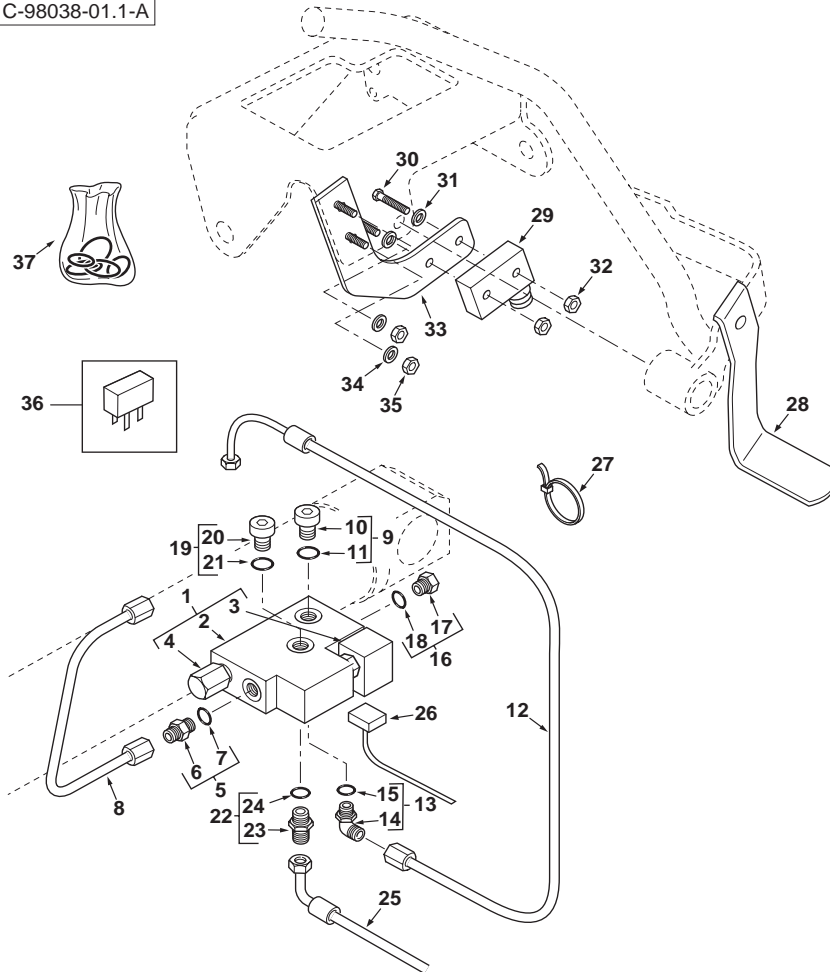

1	6109880M91		2	Valve, Lockout	Soupape verrouillage	Válvula de bloqueo.
2		1 (A) Ref. 1	1	Valve	Soupape	Válvula
3	6193308M91	1 (A) Solenoid	1	Cartridge	Cartouche	Cartucho
4	6193173M91	1 (A) Solenoid	1	Coil Assy	Ensemble de bobine	Bobina, Conj.
5	835013M91		2	Connector Assy	Ensemble connexion	Conexión, Conj.
6		5 Ref. 5	1	Connector	Connecteur	Conector
7	835024M1	5	1	O-Ring	Joint torique	Junta de tipo O
8	6109936M91		1	Tube Assy	Tuyauterie	Conjunto de tubería
8	6109938M91		1	Tube Assy	Tuyauterie	Conjunto de tubería
9	373772M91	9/16	2	Plug Assy	Ensemble bouchons	Tapón, Conj.
10		9 Ref. 9	1	Plug	Bouchon	Tapón
11	831452M1	9	1	O-Ring	Joint torique	Junta de tipo O
12	6109922M91		2	Hose Assy	Ensemble de flexible	Flexible, Conj.
13	357197X91		2	Elbow, 90°	Coude à 90°	Codo, 90°
14		10 Ref. 10	1	Elbow	Coude	Codo
15	831452M1	10	1	O-Ring	Joint torique	Junta de tipo O
16	6109935M91	7/8"	2	Connector Assy	Ensemble connexion	Conexión, Conj.
17		16 Ref. 16	1	Connector	Connecteur	Conector
18	835024M1	16	1	O-Ring	Joint torique	Junta de tipo O
19	373772M91	9/16	2	Plug Assy	Ensemble bouchons	Tapón, Conj.
20		19 Ref. 19	1	Plug	Bouchon	Tapón
21	831452M1	19	1	O-Ring	Joint torique	Junta de tipo O
22	6109947M91	9/16"	2	Restrictor	Réduction	Reducción
23		22 Ref. 22	1	Restrictor	Réduction	Reducción
24	831452M1	22	1	O-Ring	Joint torique	Junta de tipo O
25	6109923M91		1	Hose Assy	Ensemble de flexible	Flexible, Conj.
26	6102074M91		1	Harness	Faisceau	Haz
27	1664405M1		12	Tie, Cable	Attache câble	Enlace de Cable
28	6109603M1		1	Actuator	Vérin	Mecanismo de mando
29	6102075M91		1	Switch Assy	Ensemble commutat.	Conmutador, Conj.
30	3522433M2	M3 x 35	2	Screw	Vis	Tornillo
31	390752X1		2	Washer	Rondelle	Arandela
32	391216X1	M3	2	Nut	Écrou	Tuerca
33	6109602M91	Switch	1	Plate Assy	Ensemble de plaque	Placa, Conj.
34	390469X1	M5	2	Washer	Rondelle	Arandela
35	3005823X1	M5	2	Nut	Écrou	Tuerca
36	6102490M1		1	Relay	Relais	Relé
37	6194037M91	Lockout Valve	X	Kit, Seal	Pochette de joints	Juego de juntas

A Not illustrated
 Non illustrée
 No ilustrado



820 860 880 970 980
 TX760B TX860B
 TX870B TX970B

801 802 803 804 805 806 807 808 813 814 815 816 817 821 822 823 824 825 831
 832 833 834 841 842 843 844 845 851 852 853 854 855 921 922 923 931 932

98038C01.1

6199042M3

1

Jan-06

Hose Burst Kit
Coffret de Éclatement de Tuyau
Juego de rotura de tubo flexible

Loader Bucket Cylinder
Vérin de Godet Chargeur
Gato de cuchara

C-98038-02.1-A

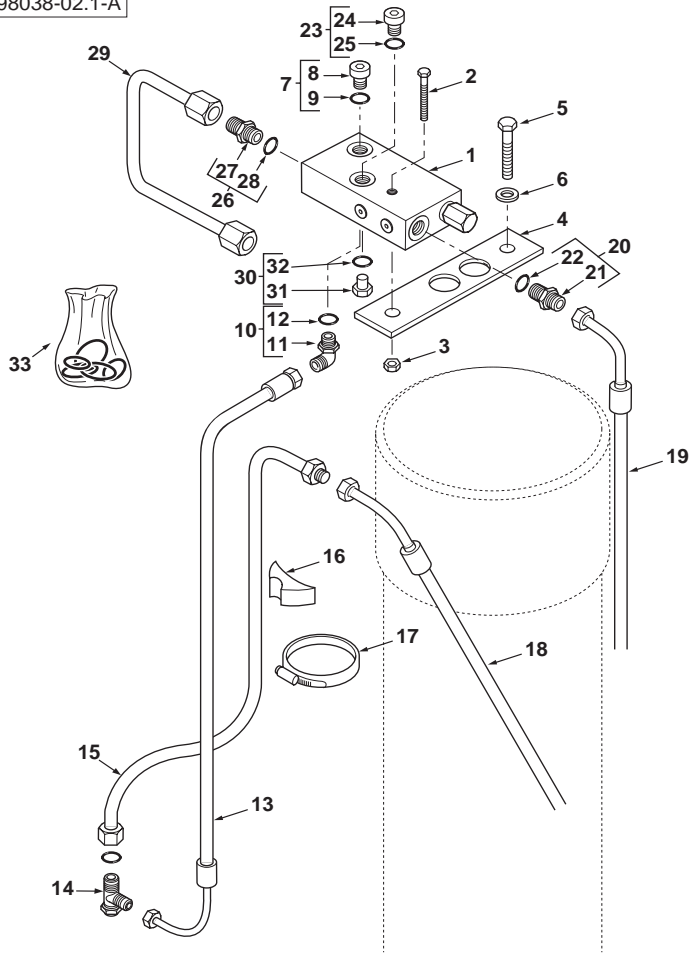

1	6109881M91		1	Valve, Lockout	Soupape verrouillage	Válvula de bloqueo.
2	339368X1	M8 x 60	2	Bolt, Lockout	Boulon	Perno
3	394367X1	M8	2	Nut, Lock	Écrou de blocage	Tuerca de retención
4	6109958M1		1	Plate	Plaque	Placa
5	3009505X1	M12 x 25	2	Bolt	Boulon	Perno
6	390735X1	M12	2	Washer	Rondelle	Arandela
7	373772M91	9/16	1	Plug Assy	Ensemble bouchons	Tapón, Conj.
8		8	1	Plug	Bouchon	Tapón
9	831452M1	8	1	O-Ring	Joint torique	Junta de tipo O
10	358781X91		1	Elbow, 45°	Coude à 45°	Codo, 45°
11		10	1	Elbow	Coude	Codo
12	831452M1	10	1	O-Ring	Joint torique	Junta de tipo O
13	6102015M91		1	Hose Assy	Ensemble de flexible	Flexible, Conj.
14	6102014M91		1	Tee	Raccord en T	Te
15	6106232M91		1	Tube Assy	Tuyauterie	Conjunto de tubería
16	L79937		1	Spacer	Entretoise	Traviesa
17	3517734M1		1	Clamp	Collier de serrage	Argolla de cierre
18	6102383M91		1	Hose Assy	Ensemble de flexible	Flexible, Conj.
19	6106233M92		1	Hose Assy	Ensemble de flexible	Flexible, Conj.
20	835013M91		1	Connector Assy	Ensemble connexion	Conexión, Conj.
21		20	1	Connector	Connecteur	Conector
22	835024M1	20	1	O-Ring	Joint torique	Junta de tipo O
23	373772M91	9/16	1	Plug Assy	Ensemble bouchons	Tapón, Conj.
24		23	1	Plug	Bouchon	Tapón
25	831452M1	23	1	O-Ring	Joint torique	Junta de tipo O
26	835013M91		1	Connector Assy	Ensemble connexion	Conexión, Conj.
27		26	1	Connector	Connecteur	Conector
28	835024M1	26	1	O-Ring	Joint torique	Junta de tipo O
29	6109956M91		1	Tube Assy	Tuyauterie	Conjunto de tubería
30	835087M91	9/16	1	Plug Assy	Ensemble bouchons	Tapón, Conj.
31		30	1	Plug	Bouchon	Tapón
32	831452M1	30	1	O-Ring	Joint torique	Junta de tipo O
33	6194038M91	Lockout Valve	X	Kit, Seal	Pochette de joints	Juego de juntas



820 860 880 970 980
 TX760B TX860B
 TX870B TX970B

801 802 803 804 805 806 807 808 813 814 815 816 817 821 822 823 824 825 831
 832 833 834 841 842 843 844 845 851 852 853 854 855 921 922 923 931 932

98038C02.1

6199042M3

1

Jan-06

Loader
Chargeur
Cargadora

Arms
Bras
Brazo

Yellow
Jaune
Amarillo

C-65001-01.1-A

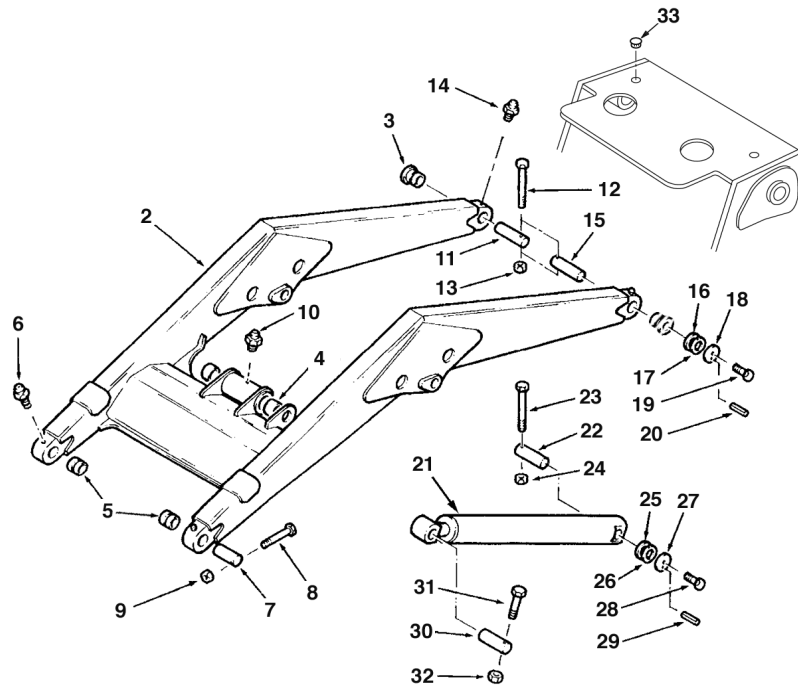

1	6100694M94		1	Arm Assy	Ensemble de bras	Brazo, Conj.
2		1	➡ Ref. 1	Arm	Bras	Brazo
3	3520034M3	1		Bushing	Bague	Anillo
4	3520032M1	1		Bushing	Bague	Anillo
5	3522862M2	1		Bushing	Bague	Anillo
6	339608X1			Fitting, Grease	Graisneur	Engrasador
7	3520042M5	40 x 212 mm		Pin	Axe	Pasador
8	3516014M1	M10 x 90		Screw	Vis	Tornillo
9	1440329X1	M10		Nut, Lock	Écrou de blocage	Tuerca de retención
10	339608X1			Fitting, Grease	Graisneur	Engrasador
11	3520046M6	50 x 235 mm		Pin	Axe	Pasador
12	3516015M1	M10 x 100		Screw	Vis	Tornillo
13	1440329X1	M10		Nut, Lock	Écrou de blocage	Tuerca de retención
14	339608X1			Fitting, Grease	Graisneur	Engrasador
15	3520046M6	50 x 235 mm		Pin	Axe	Pasador
16	3522962M1			Washer, Thrust	Rondelle de butée	Arandela de tope
17	3522963M1			Washer, Thrust	Rondelle de butée	Arandela de tope
18	3522717M3	M16		Washer	Rondelle	Arandela
19	339613X1	M16 x 25		Screw	Vis	Tornillo
20	1441736X1			Pin, Roll	Goupille élastique	Pasador elástico
21		⊙ Loader Hydraulics		Cylinder	Cylindre	Cilindro
22	3520046M6	50 x 235 mm		Pin	Axe	Pasador
23	3516015M1	M10 x 100		Screw	Vis	Tornillo
24	1440329X1	M10		Nut, Lock	Écrou de blocage	Tuerca de retención
25	3522962M1			Washer, Thrust	Rondelle de butée	Arandela de tope
26	3522963M1			Washer, Thrust	Rondelle de butée	Arandela de tope
27	3522717M3	M16		Washer	Rondelle	Arandela
28	339613X1	M16 x 25		Screw	Vis	Tornillo
29	1441736X1			Pin, Roll	Goupille élastique	Pasador elástico
30	6109663M1		◀	Pin	Axe	Pasador
30	6109683M1		▶	Pin	Axe	Pasador
31	3516014M1	M10 x 90		Screw	Vis	Tornillo
32	1440329X1	M10		Nut, Lock	Écrou de blocage	Tuerca de retención
33	1680191M1			Plug	Bouchon	Tapón



820 860 880 970 980
TX760B TX860B
TX870B TX970B

801 802 803 804 805 806 807 808 813 814 815 816 817 821 822 823 824 825 831
832 833 834 841 842 843 844 845 851 852 853 854 855 921 922 923 931 932

65001C01.1

6199042M3

1

Jan-06

Loader
Chargeur
Cargadora

Arms
Bras
Brazo

White
Blanc
Blanco

C-65002-01.1-A

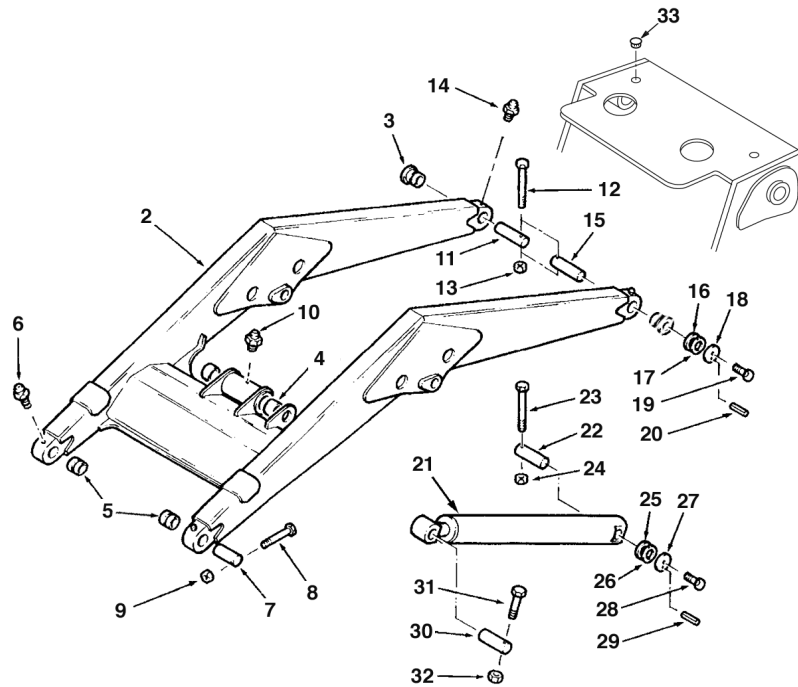

1	6107941M92			1	Arm Assy	Ensemble de bras	Brazo, Conj.
2		1	➔ Ref. 1	1	Arm	Bras	Brazo
3	3520034M3	1		2	Bushing	Bague	Anillo
4	3520032M1	1		2	Bushing	Bague	Anillo
5	3522862M2	1		2	Bushing	Bague	Anillo
6	339608X1			2	Fitting, Grease	Graisneur	Engrasador
7	3520042M5	40 x 212 mm		2	Pin	Axe	Pasador
8	3516014M1	M10 x 90		2	Screw	Vis	Tornillo
9	1440329X1	M10		2	Nut, Lock	Écrou de blocage	Tuerca de retención
10	339608X1			1	Fitting, Grease	Graisneur	Engrasador
11	3520046M6	50 x 235 mm		1	Pin	Axe	Pasador
12	3516015M1	M10 x 100		2	Screw	Vis	Tornillo
13	1440329X1	M10		2	Nut, Lock	Écrou de blocage	Tuerca de retención
14	339608X1			2	Fitting, Grease	Graisneur	Engrasador
15	3520046M6	50 x 235 mm		1	Pin	Axe	Pasador
16	3522962M1			1	Washer, Thrust	Rondelle de butée	Arandela de tope
17	3522963M1			1	Washer, Thrust	Rondelle de butée	Arandela de tope
18	3522717M3	M16		1	Washer	Rondelle	Arandela
19	339613X1	M16 x 25		1	Screw	Vis	Tornillo
20	1441736X1			1	Pin, Roll	Goupille élastique	Pasador élastico
21		⦿ Loader Hydraulics		2	Cylinder	Cylindre	Cilindro
22	3520046M6	50 x 235 mm		2	Pin	Axe	Pasador
23	3516015M1	M10 x 100		2	Screw	Vis	Tornillo
24	1440329X1	M10		2	Nut, Lock	Écrou de blocage	Tuerca de retención
25	3522962M1			2	Washer, Thrust	Rondelle de butée	Arandela de tope
26	3522963M1			2	Washer, Thrust	Rondelle de butée	Arandela de tope
27	3522717M3	M16		2	Washer	Rondelle	Arandela
28	339613X1	M16 x 25		2	Screw	Vis	Tornillo
29	1441736X1			2	Pin, Roll	Goupille élastique	Pasador élastico
30	6109663M1	◀		1	Pin	Axe	Pasador
30	6109683M1	▶		1	Pin	Axe	Pasador
31	3516014M1	M10 x 90		2	Screw	Vis	Tornillo
32	1440329X1	M10		2	Nut, Lock	Écrou de blocage	Tuerca de retención
33	1680191M1			2	Plug	Bouchon	Tapón



820 860 880 970 980
TX760B TX860B
TX870B TX970B

801 802 803 804 805 806 807 808 809 810 811 812 813 814 815 816 817 821 822
823 824 825 831 832 833 834 841 842 843 844 845 851 852 853 854 855 921 922
923 931 932

65002C01.1

6199042M3

1

Jan-06

Loader
Chargeur
Cargadora

Links
Articulation
Articulación

Yellow
Jaune
Amarillo

C-65001-02.1-A

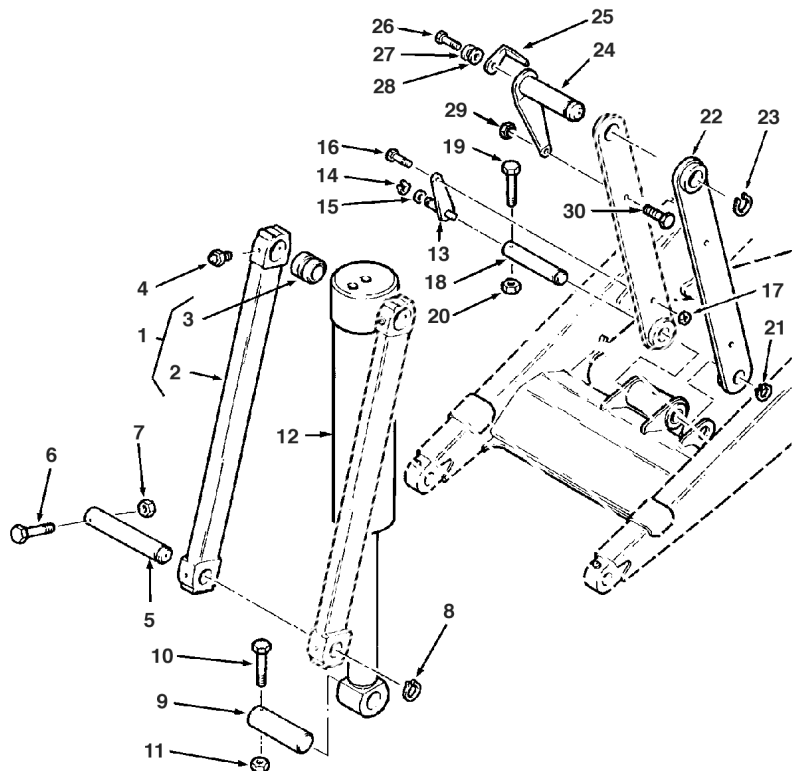

1	6101983M91		2	Link	Maillon	Eslabón
2		1 Ref.1	1	Link	Maillon	Eslabón
3	3521716M1	1	1	Bushing	Bague	Anillo
4	339608X1		2	Fitting, Grease	Graisneur	Engrasador
5	3521723M5	50 x 288 mm	1	Pin	Axe	Pasador
6	3501289M1	M10 x 110	1	Screw	Vis	Tornillo
7	1440329X1	M10	1	Nut, Lock	Écrou de blocage	Tuerca de retención
8	391129X1		1	Ring, Snap	Anneau d'arrêt	Anillo de resorte
9	6106216M1	50 x 175 mm	1	Pin	Axe	Pasador
10	3516014M1	M10 x 90	1	Screw	Vis	Tornillo
11	1440329X1	M10	1	Nut, Lock	Écrou de blocage	Tuerca de retención
12		Loader Hydraulics	1	Cylinder	Cylindre	Cilindro
13	3521757M93		1	Pivot	Pivot	Pivote
14	3516762M1		1	Ring, Snap	Anneau d'arrêt	Anillo de resorte
15	339300X1		1	Washer	Rondelle	Arandela
16	3516013M1	M10 x 40	1	Screw	Vis	Tornillo
17	1440329X1	M10	1	Nut, Lock	Écrou de blocage	Tuerca de retención
18	3520465M5	40 x 299 mm	1	Pin	Axe	Pasador
19	3516014M1	M10 x 90	1	Screw	Vis	Tornillo
20	1440329X1	M10	1	Nut, Lock	Écrou de blocage	Tuerca de retención
21	339820X1		1	Ring, Snap	Anneau d'arrêt	Anillo de resorte
22	3522361M93		2	Link	Maillon	Eslabón
23	391129X1		1	Ring, Snap	Anneau d'arrêt	Anillo de resorte
24	3522679M94		1	Pin	Axe	Pasador
25	3516352M1		1	Indicator	Témoin	Indicador
26	339081X1	M10 x 20	1	Screw	Vis	Tornillo
27	390734X1	M10	1	Washer	Rondelle	Arandela
28	339376X1	M10	1	Washer, Lock	Rondelle de blocage	Arandela de freno
29	1440329X1	M10	1	Nut, Lock	Écrou de blocage	Tuerca de retención
30	3516013M1	M10 x 40	1	Screw	Vis	Tornillo



820 860 880 970 980
TX760B TX860B
TX870B TX970B

801 802 803 804 805 806 807 808 813 814 815 816 817 821 822 823 824 825 831
832 833 834 841 842 843 844 845 851 852 853 854 855 921 922 923 931 932

65001C02.1

6199042M3

1

Jan-06

Loader
Chargeur
Cargadora

Links
Articulation
Articulación

White
Blanc
Blanco

C-65002-02.1-A

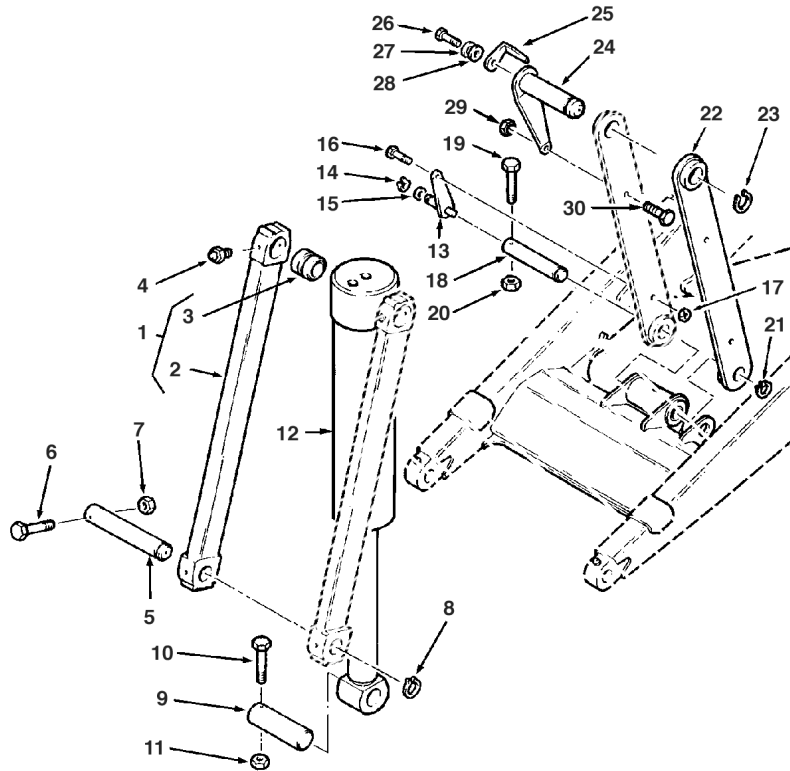

1	6101983Z91			2	Link Assy	Ensemble de maillon	Eslabón, Conj.
2		1	➔ Ref.1	1	Link	Maillon	Eslabón
3	3521716M1	1		1	Bushing	Bague	Anillo
4	339608X1			2	Fitting, Grease	Graisneur	Engrasador
5	3521723M5		50 x 288 mm	1	Pin	Axe	Pasador
6	3501289M1		M10 x 110	1	Screw	Vis	Tornillo
7	1440329X1		M10	1	Nut, Lock	Écrou de blocage	Tuerca de retención
8	391129X1			1	Ring, Snap	Anneau d'arrêt	Anillo de resorte
9	6106216M1		50 x 175 mm	1	Pin	Axe	Pasador
10	3516014M1		M10 x 90	1	Screw	Vis	Tornillo
11	1440329X1		M10	1	Nut, Lock	Écrou de blocage	Tuerca de retención
12			⦿ Loader Hydraulics	1	Cylinder	Cylindre	Cilindro
13	3521757M93			1	Pivot	Pivot	Pivote
14	3516762M1			1	Ring, Snap	Anneau d'arrêt	Anillo de resorte
15	339300X1			1	Washer	Rondelle	Arandela
16	3516013M1		M10 x 40	1	Screw	Vis	Tornillo
17	1440329X1		M10	1	Nut, Lock	Écrou de blocage	Tuerca de retención
18	3520465M5		40 x 299 mm	1	Axe	Pasador	Pasador
19	3516014M1		M10 x 90	1	Screw	Vis	Tornillo
20	1440329X1		M10	1	Nut, Lock	Écrou de blocage	Tuerca de retención
21	339820X1			1	Ring, Snap	Anneau d'arrêt	Anillo de resorte
22	3522361Z93			2	Link Assy	Ensemble de maillon	Eslabón, Conj.
23	391129X1			1	Ring, Snap	Anneau d'arrêt	Anillo de resorte
24	3522679M94			1	Pin	Axe	Pasador
25	3516352M1			1	Indicator	Témoin	Indicador
26	339081X1		M10 x 20	1	Screw	Vis	Tornillo
27	390734X1		M10	1	Washer	Rondelle	Arandela
28	339376X1		M10	1	Washer, Lock	Rondelle de blocage	Arandela de freno
29	1440329X1		M10	1	Nut, Lock	Écrou de blocage	Tuerca de retención
30	3516013M1		M10 x 40	1	Screw	Vis	Tornillo



820 860 880 970 980
TX760B TX860B
TX870B TX970B

801 802 803 804 805 806 807 808 809 810 811 812 813 814 815 816 817 821 822
823 824 825 831 832 833 834 841 842 843 844 845 851 852 853 854 855 921 922
923 931 932

65002C02.1

6199042M3

1

Jan-06

Loader
Chargeur
Cargadora

Return To Dig
Retour Pelle
Retorno a excavación

Mechanical
Mécanique
Mecánica

C-65001-03.1-A

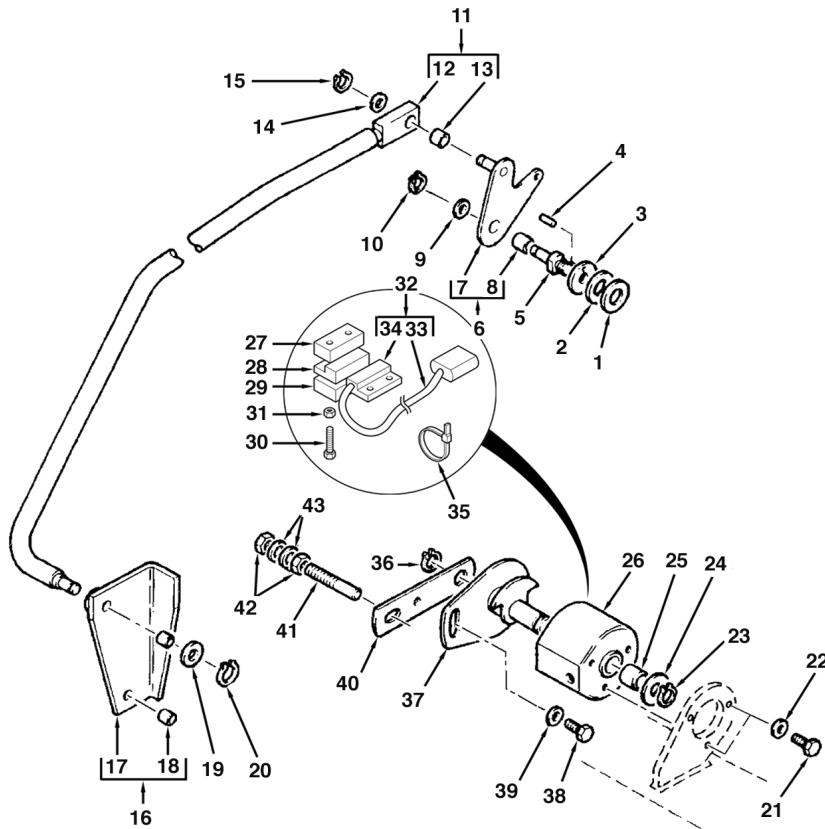

1	3522963M1		1	Washer, Thrust	Rondelle de butée	Arandela de tope
2	3522962M1		1	Washer, Thrust	Rondelle de butée	Arandela de tope
3	3522717M3	M16	1	Washer	Rondelle	Arandela
4	1441736X1		1	Pin, Roll	Goupille élastique	Pasador elástico
5	3521799M5		1	Shaft	Arbre	Árbol
6	3516765M91	65001C04.1 34	1	Arm Assy	Ensemble de bras	Brazo, Conj.
7		6 Ref.6	1	Arm	Bras	Brazo
8	3516761M1	6	1	Bushing	Bague	Anillo
9	339300X1		1	Washer	Rondelle	Arandela
10	3516762M1		1	Ring, Snap	Anneau d'arrêt	Anillo de resorte
11	6107911M91		1	Link Assy	Ensemble de maillon	Eslabón, Conj.
12		11 Ref.11	1	Link	Maillon	Eslabón
13	3516761M1	11	1	Bushing	Bague	Anillo
14	339300X1		1	Washer	Rondelle	Arandela
15	3516762M1		1	Ring, Snap	Anneau d'arrêt	Anillo de resorte
16	6100971M91		1	Mount	Support de fixation	Soporte de fijación
17		14 Ref.14	1	Link	Maillon	Eslabón
18	3516761M1	14	1	Bushing	Bague	Anillo
19	339300X1		1	Washer	Rondelle	Arandela
20	3516762M1		1	Ring, Snap	Anneau d'arrêt	Anillo de resorte
21	339123X1	M8 x 20	3	Bolt	Boulon	Perno
22	339374X1	M8	3	Washer, Lock	Rondelle de blocage	Arandela de freno
23	3516762M1		1	Ring, Snap	Anneau d'arrêt	Anillo de resorte
24	339300X1		1	Washer	Rondelle	Arandela
25	3516761M1		1	Bushing	Bague	Anillo
26	3521963M94		1	Housing	Carter	Cárter
27	3522874M1		2	Plate	Plaque	Placa
28	3522649M1		1	Magnet	Aimant	Imán
29	3522093M1		2	Spacer	Entretoise	Traviesa
30	3522673M2	M3 x 25	4	Screw	Vis	Tornillo
31	3522674M1	M3	4	Washer, Lock	Rondelle de blocage	Arandela de freno
32	6101674M91		1	Harness	Faisceau	Haz
33		32 Ref.32	1	Harness	Faisceau	Haz
34	3522650M2	32	1	Sensor	Capteur	Captador
35	1862425M1		X	Tie, Cable	Attache câble	Enlace de Cable
36	3516762M1		1	Ring, Snap	Anneau d'arrêt	Anillo de resorte
37	3521967M95		1	Arm Assy	Ensemble de bras	Brazo, Conj.
38	339123X1	M8 x 20	1	Bolt	Boulon	Perno
39	390972X1	M8	1	Washer	Rondelle	Arandela
40	3516192M91		1	Arm Assy	Ensemble de bras	Brazo, Conj.
41	3522075M2		1	Pivot	Pivot	Pivote
42	3009693X1	M10	2	Nut	Écrou	Tuerca
43	339376X1	M10	2	Washer, Lock	Rondelle de blocage	Arandela de freno



820 860 880 970 980
TX760B TX860B
TX870B TX970B

801 802 803 804 805 806 807 808 813 814 815 816 817 821 822 823 824 825 831
832 833 834 841 842 843 844 845 851 852 853 854 855 921 922 923 931 932

65001C03.1

6199042M3

1

Jan-06

Loader
Chargeur
Cargadora

Return To Dig
Retour Pelle
Retorno a excavación

Mechanical
Mécanique
Mecánica

C-65001-04.1-A

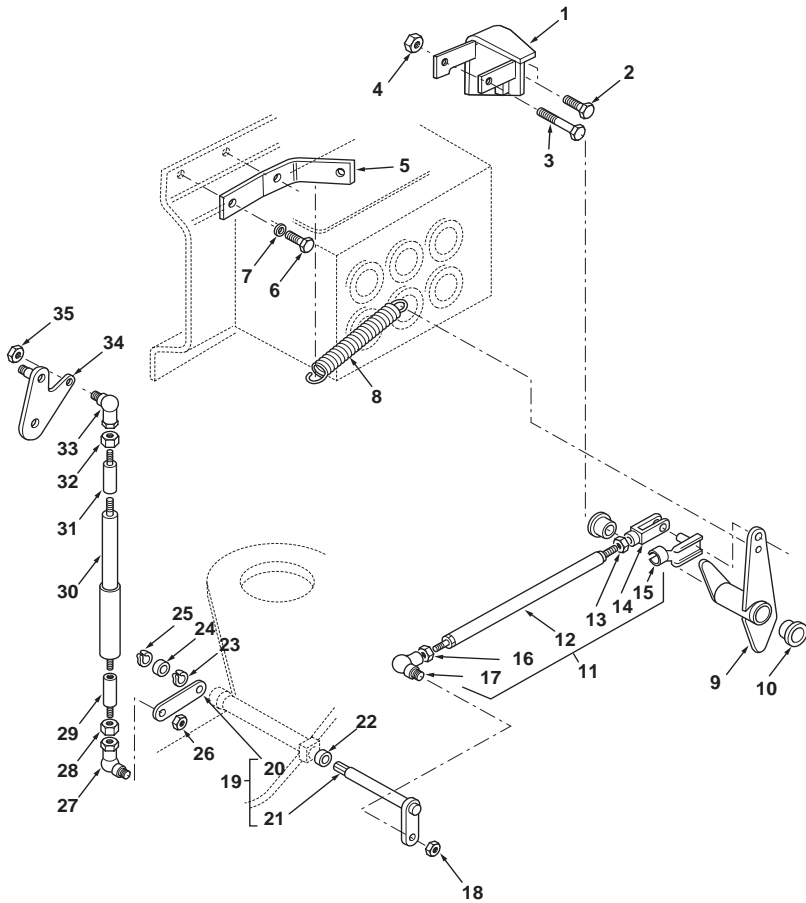

1	6109363M92		1	Bracket Assy	Ensemble chaise palier	Cuchara, Conj.
2	3009492X1	M10 x 25	2	Screw	Vis	Tornillo
3	3009517X1	M12 x 100	1	Screw	Vis	Tornillo
4	1440330X1	M12	1	Nut	Écrou	Tuerca
5	6109369M1		1	Anchor	Ancre	Ancla
6	3009492X1	M10 x 25	2	Screw	Vis	Tornillo
7	385362X1	M10	2	Washer	Rondelle	Arandela
8	3519680M2		1	Spring	Ressort	Muelle
9	6106694M91		1	Lever Assy	Ensemble de levier	Palanca, Conj.
10	6106560M1		2	Bushing	Bague	Anillo
11	6106691M92		1	Rod Assy	Ensemble tringlerie	Tirantes, Conj.
12		11	1	Rod	Tringle	Vástago
13	3009693X1	11 M10	1	Nut	Écrou	Tuerca
14	3521833M1	11	1	Clevis	Chape	Brida
15	3521834M1	11	1	Pin, Clevis	Axe de chape	Eje de brida
16	3009693X1	11 M10	1	Nut	Écrou	Tuerca
17	3521794M91	11	1	Ball Joint	Rotule	Rotula
18	1440329X1	M10	1	Nut, Lock	Écrou de blocage	Tuerca de retención
19	6109072M91		1	Arm Assy	Ensemble de bras	Brazo, Conj.
20		19	1	Lever	Levier	Palanca
21		19	1	Arm	Bras	Brazo
22	3521514M5		1	Bushing	Bague	Anillo
23	339710X1		1	Ring, Snap	Anneau d'arrêt	Anillo de resorte
24	3521514M5		1	Bushing	Bague	Anillo
25	339710X1		1	Ring, Snap	Anneau d'arrêt	Anillo de resorte
26	1440329X1	M10	1	Nut, Lock	Écrou de blocage	Tuerca de retención
27	3521794M91		1	Ball Joint	Rotule	Rotula
28	3009693X1	M10	1	Nut	Écrou	Tuerca
29	6106240M1		1	Turnbuckle	Tendeur de tringle	Tomiquete
30	6106239M91		1	Damper Assy	Ensemble d'amortiss.	Antivibrador, Conj.
31	6106241M1	LH Thread	1	Turnbuckle	Tendeur de tringle	Tomiquete
32	6107340M1	M10 - LH	1	Nut	Écrou	Tuerca
33	3521889M91	LH Thread	1	Ball Joint	Rotule	Rotula
34	3516765M91	65001C03.1 6	1	Arm Assy	Ensemble de bras	Brazo, Conj.
35	1440329X1	M10	1	Nut, Lock	Écrou de blocage	Tuerca de retención



820 860 880 970 980
TX760B TX860B
TX870B TX970B

801 802 803 804 805 806 807 808 813 814 815 816 817 821 822 823 824 825 831
832 833 834 841 842 843 844 845 851 852 853 854 855 921 922 923 931 932

65001C04.1

6199042M3

1

Jan-06

Loader
Chargeur
Cargadora

Return To Dig
Retour Pelle
Retorno a excavación

Mechanical
Mécanique
Mecánica

C-65002-03.1-A

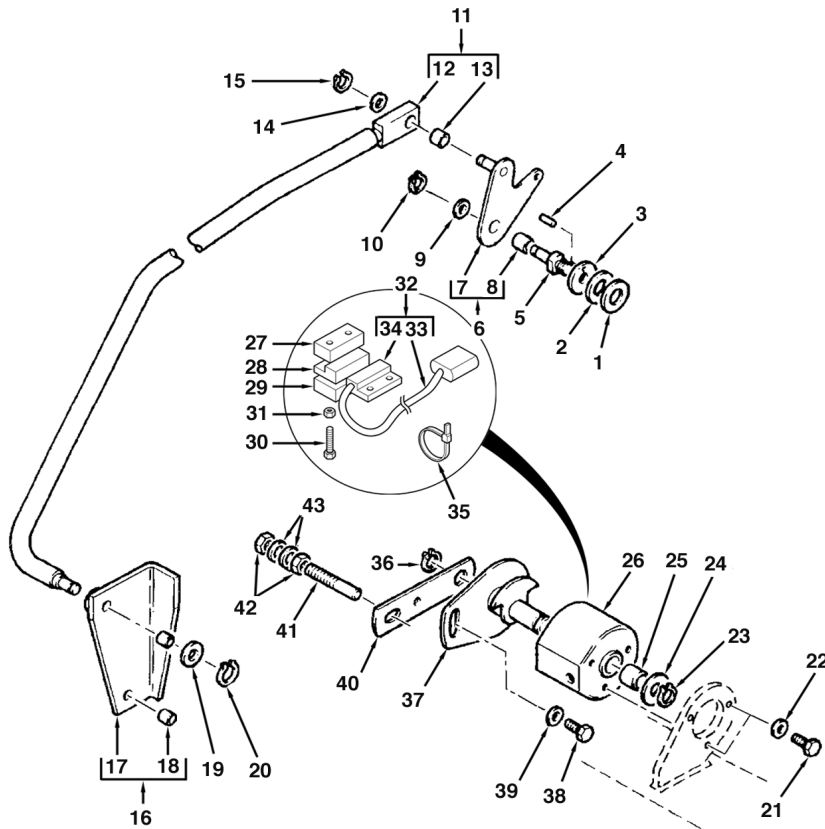

1	3522963M1		1	Washer, Thrust	Rondelle de butée	Arandela de tope
2	3522962M1		1	Washer, Thrust	Rondelle de butée	Arandela de tope
3	3522717M3	M16	1	Washer	Rondelle	Arandela
4	1441736X1		1	Pin, Roll	Goupille élastique	Pasador elástico
5	3521799M5		1	Shaft	Arbre	Árbol
6	3516765M91	65002C04.1 34	1	Arm Assy	Ensemble de bras	Brazo, Conj.
7		6 Ref.6	1	Arm	Bras	Brazo
8	3516761M1	6	1	Bushing	Bague	Anillo
9	339300X1		1	Washer	Rondelle	Arandela
10	3516762M1		1	Ring, Snap	Anneau d'arrêt	Anillo de resorte
11	6107911M91		1	Link Assy	Ensemble de maillon	Eslabón, Conj.
12		11 Ref.11	1	Link	Maillon	Eslabón
13	3516761M1	11	1	Bushing	Bague	Anillo
14	339300X1		1	Washer	Rondelle	Arandela
15	3516762M1		1	Ring, Snap	Anneau d'arrêt	Anillo de resorte
16	6100971M91		1	Mount	Support de fixation	Soporte de fijación
17		14 Ref.14	1	Link	Maillon	Eslabón
18	3516761M1	14	1	Bushing	Bague	Anillo
19	339300X1		1	Washer	Rondelle	Arandela
20	3516762M1		1	Ring, Snap	Anneau d'arrêt	Anillo de resorte
21	339123X1	M8 x 20	3	Bolt	Boulon	Perno
22	339374X1	M8	3	Washer, Lock	Rondelle de blocage	Arandela de freno
23	3516762M1		1	Ring, Snap	Anneau d'arrêt	Anillo de resorte
24	339300X1		1	Washer	Rondelle	Arandela
25	3516761M1		1	Bushing	Bague	Anillo
26	3521963M94		1	Housing	Carter	Cárter
27	3522874M1		2	Plate	Plaque	Placa
28	3522649M1		1	Magnet	Aimant	Imán
29	3522093M1		2	Spacer	Entretoise	Traviesa
30	3522673M2	M3 x 25	4	Screw	Vis	Tornillo
31	3522674M1	M3	4	Washer, Lock	Rondelle de blocage	Arandela de freno
32	6101674M91		1	Harness	Faisceau	Haz
33		32 Ref.32	1	Harness	Faisceau	Haz
34	3522650M2	32	1	Sensor	Capteur	Captador
35	1862425M1		X	Tie, Cable	Attache câble	Enlace de Cable
36	3516762M1		1	Ring, Snap	Anneau d'arrêt	Anillo de resorte
37	3521967M95		1	Arm Assy	Ensemble de bras	Brazo, Conj.
38	339123X1	M8 x 20	1	Bolt	Boulon	Perno
39	390972X1	M8	1	Washer	Rondelle	Arandela
40	3516192M91		1	Arm Assy	Ensemble de bras	Brazo, Conj.
41	3522075M2		1	Pivot	Pivot	Pivote
42	3009693X1	M10	2	Nut	Écrou	Tuerca
43	339376X1	M10	2	Washer, Lock	Rondelle de blocage	Arandela de freno



820 860 880 970 980
TX760B TX860B
TX870B TX970B

801 802 803 804 805 806 807 808 809 810 811 812 813 814 815 816 817 821 822
823 824 825 831 832 833 834 841 842 843 844 845 851 852 853 854 855 921 922
923 931 932

65002C03.1

6199042M3

1

Jan-06

Loader
Chargeur
Cargadora

Return To Dig
Retour Pelle
Retorno a excavación

Mechanical
Mécanique
Mecánica

C-65002-04.1-A

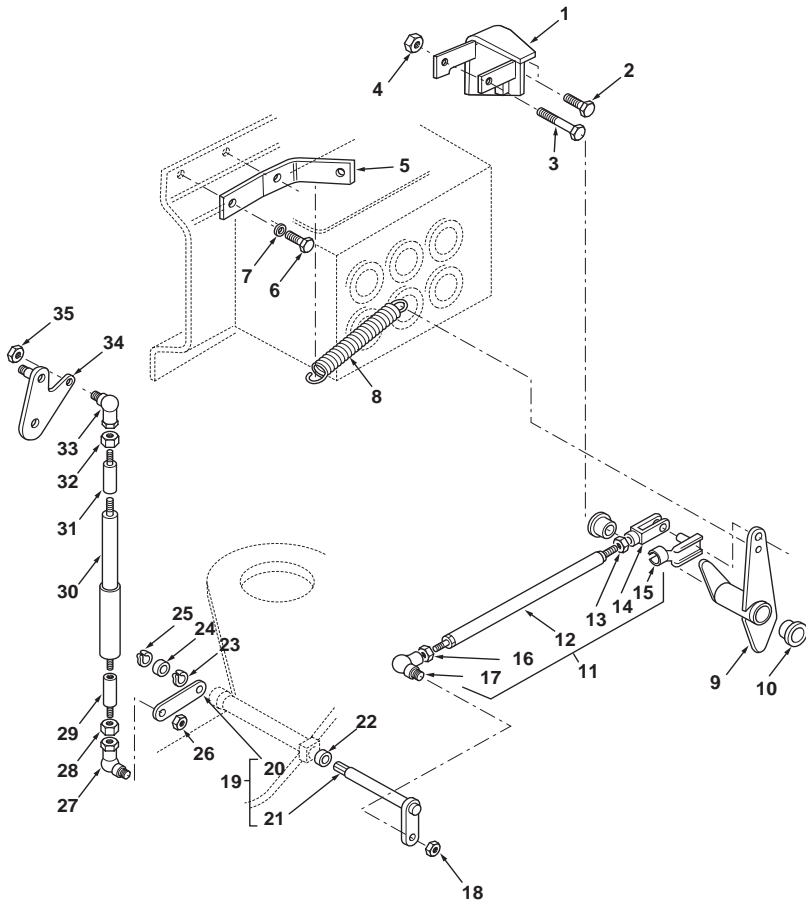

1	6109363M92		1	Bracket Assy	Ensemble chaise palier	Cuchara, Conj.
2	3009492X1	M10 x 25	2	Screw	Vis	Tornillo
3	3009517X1	M12 x 100	1	Screw	Vis	Tornillo
4	1440330X1	M12	1	Nut	Écrou	Tuerca
5	6109369M1		1	Anchor	Ancre	Ancla
6	3009492X1	M10 x 25	2	Screw	Vis	Tornillo
7	385362X1	M10	2	Washer	Rondelle	Arandela
8	3519680M2		1	Spring	Ressort	Muelle
9	6106694M91		1	Lever Assy	Ensemble de levier	Palanca, Conj.
10	6106560M1		2	Bushing	Bague	Anillo
11	6106691M92		1	Rod Assy	Ensemble tringlerie	Tirantes, Conj.
12		11	1	Rod	Tringle	Vástago
13	3009693X1	11 M10	1	Nut	Écrou	Tuerca
14	3521833M1	11	1	Clevis	Chape	Brida
15	3521834M1	11	1	Pin, Clevis	Axe de chape	Eje de brida
16	3009693X1	11 M10	1	Nut	Écrou	Tuerca
17	3521794M91	11	1	Ball Joint	Rotule	Rotula
18	1440329X1	M10	1	Nut, Lock	Écrou de blocage	Tuerca de retención
19	6109072M91		1	Arm Assy	Ensemble de bras	Brazo, Conj.
20		19	1	Lever	Levier	Palanca
21		19	1	Arm	Bras	Brazo
22	3521514M5		1	Bushing	Bague	Anillo
23	339710X1		1	Ring, Snap	Anneau d'arrêt	Anillo de resorte
24	3521514M5		1	Bushing	Bague	Anillo
25	339710X1		1	Ring, Snap	Anneau d'arrêt	Anillo de resorte
26	1440329X1	M10	1	Nut, Lock	Écrou de blocage	Tuerca de retención
27	3521794M91		1	Ball Joint	Rotule	Rotula
28	3009693X1	M10	1	Nut	Écrou	Tuerca
29	6106240M1		1	Turnbuckle	Tendeur de tringle	Tomiquete
30	6106239M91		1	Damper Assy	Ensemble d'amortiss.	Antivibrador, Conj.
31	6106241M1	LH Thread	1	Turnbuckle	Tendeur de tringle	Tomiquete
32	6107340M1	M10 - LH	1	Nut	Écrou	Tuerca
33	3521889M91	LH Thread	1	Ball Joint	Rotule	Rotula
34	3516765M91	65002C03.1 6	1	Arm Assy	Ensemble de bras	Brazo, Conj.
35	1440329X1	M10	1	Nut, Lock	Écrou de blocage	Tuerca de retención



820 860 880 970 980
TX760B TX860B
TX870B TX970B

801 802 803 804 805 806 807 808 809 810 811 812 813 814 815 816 817 821 822
823 824 825 831 832 833 834 841 842 843 844 845 851 852 853 854 855 921 922
923 931 932

65002C04.1

6199042M3

1

Jan-06

Loader
Chargeur
Cargadora

Safety Strut
Béquille de Sécurité
Sostén de seguridad

C-65001-05.1-A

1	6101183M92			1	Support Assy	Ensemble de support	Apoyadero, Conj.
2		1	 Ref.1	1	Support	Support	Soporte
3	1471300M1	1	5 mm	1	Stop	Butée	Tope
4	1458633M3	1	25 mm	1	Stop	Butée	Tope
5	3521910M2	1		1	Pin, Linch	Goupille d'arrêt	Pasador de parada
6	1442994X1	1		1	Pin, Split	Goupille	Pasador
7	3517165M1	1		1	Chain	Chaîne	Cadena
8	377165X1	1		1	Pin, Linch	Goupille d'arrêt	Pasador de parada

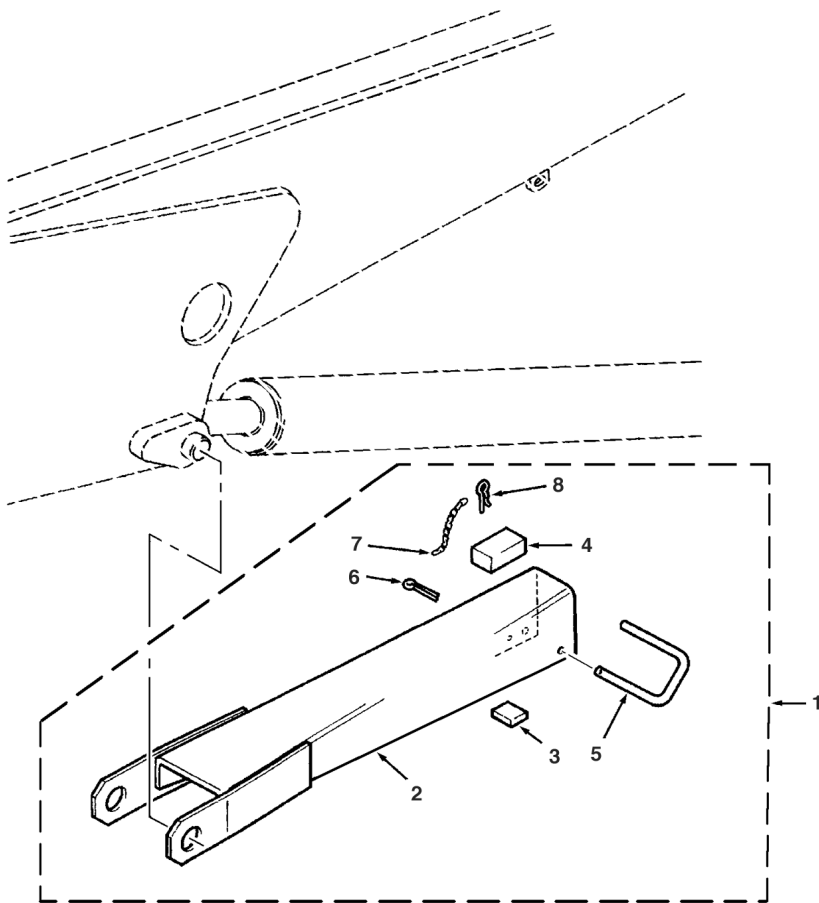

820 860 880 970 980
TX760B TX860B
TX870B TX970B

801 802 803 804 805 806 807 808 813 814 815 816 817 821 822 823 824 825 831
832 833 834 841 842 843 844 845 851 852 853 854 855 921 922 923 931 932

65001C05.1

6199042M3

1

Jan-06

Loader
Chargeur
Cargadora

Safety Strut
Béquille de Sécurité
Sostén de seguridad

C-65002-05.1-A

1	6101183M92			1	Support Assy	Ensemble de support	Apoyadero, Conj.
2		1	 Ref.1	1	Support	Support	Soporte
3	1471300M1	1	5 mm	1	Stop	Butée	Tope
4	1458633M3	1	25 mm	1	Stop	Butée	Tope
5	3521910M2	1		1	Pin, Linch	Goupille d'arrêt	Pasador de parada
6	1442994X1	1		1	Pin, Split	Goupille	Pasador
7	3517165M1	1		1	Chain	Chaîne	Cadena
8	377165X1	1		1	Pin, Linch	Goupille d'arrêt	Pasador de parada

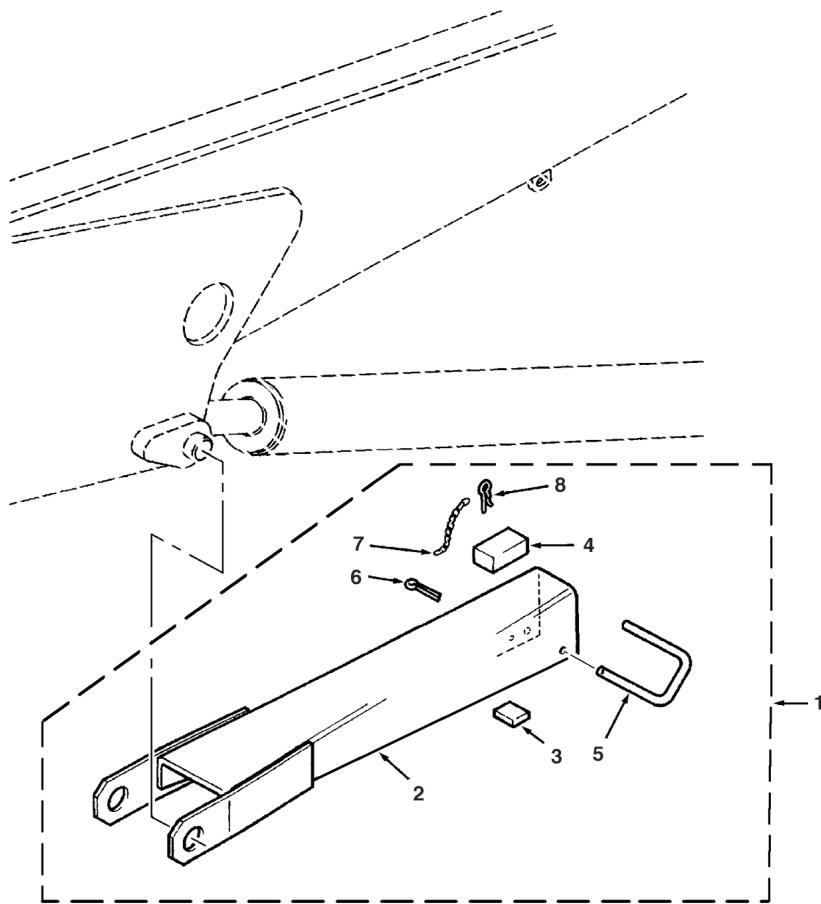

820 860 880 970 980
TX760B TX860B
TX870B TX970B

801 802 803 804 805 806 807 808 809 810 811 812 813 814 815 816 817 821 822
823 824 825 831 832 833 834 841 842 843 844 845 851 852 853 854 855 921 922
923 931 932

65002C05.1

6199042M3

1

Jan-06

Loader Controls
Commandes de Chargeur
Mandos de cargadora

Upper Control Levers
Partie Supérieure
Palancas de mando superiores

7 in 1 Bucket
 7 in 1 Bucket
 7 in 1 Bucket

C-68003-01.1-A

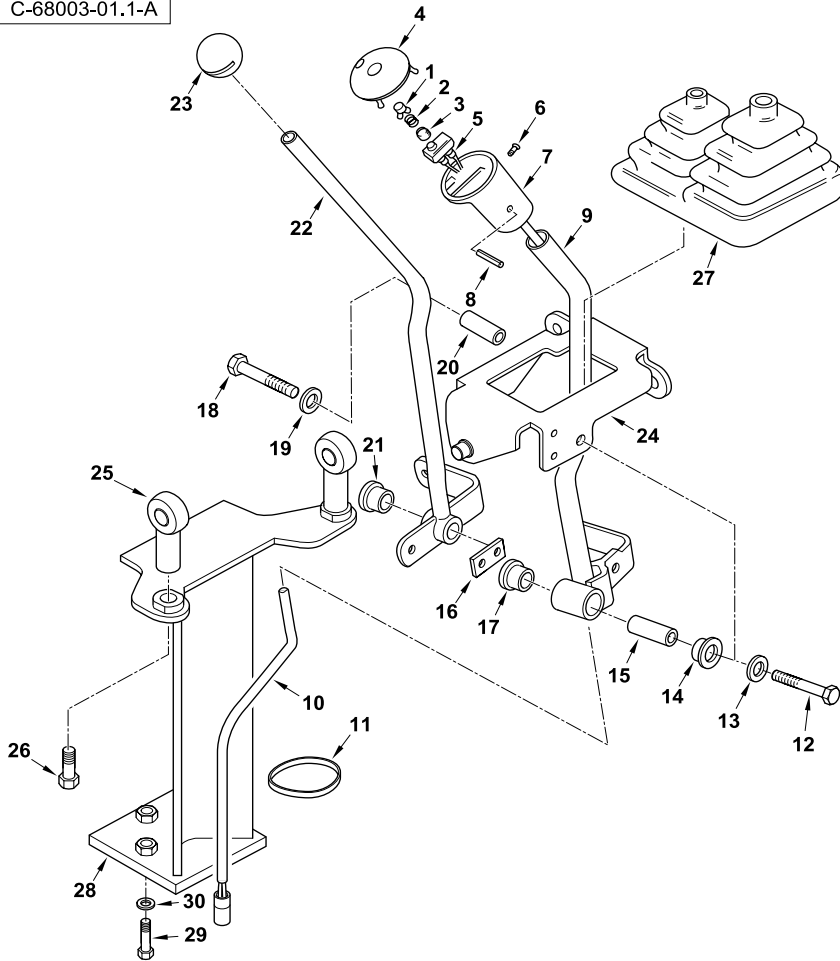

1	3521894M4		2	Button	Bouton	Botón
2	3520328M3		2	Spring	Ressort	Muelle
3	3522894M1		2	Boot	Soufflet	Fuelle
4	3522285M5		1	Knob	Boule	Bola
5	3522507M3		4	Pin	Axe	Pasador
6	3516886M1		2	Screw	Vis	Tornillo
7	3522621M5		1	Grip	Poignée de levier	Empuñ. Palanca
8	3019531X1		1	Pin, Roll	Goupille élastique	Pasador elástico
9	6109383M91		1	Lever Assy	Ensemble de levier	Palanca, Conj.
10	3516043M94		1	Harness	Faisceau	Haz
11	1664405M1		1	Tie, Cable	Attache câble	Enlace de Cable
12	339291X1	M8 x 55	1	Screw	Vis	Tornillo
13	6108769M1	M8	1	Washer, Lock	Rondelle de blocage	Arandela de freno
14	6106560M1		1	Bushing	Bague	Anillo
15	6106561M3		1	Spacer	Entretoise	Traviesa
16	6106562M1		1	Plate	Plaque	Placa
17	6106560M1		1	Bushing	Bague	Anillo
18	339291X1	M8 x 55	1	Screw	Vis	Tornillo
19	6108769M1	M8	1	Washer, Lock	Rondelle de blocage	Arandela de freno
20	6106561M3		1	Spacer	Entretoise	Traviesa
21	6106560M1		2	Bushing	Bague	Anillo
22	6109386M91		1	Lever Assy	Ensemble de levier	Palanca, Conj.
23	3509755M2		1	Knob	Boule	Bola
24	6109381M91		1	Cradle	Berceau	Soporte
25	6102844M1		2	Mount	Support de fixation	Soporte de fijación
26	3009505X1	M12 x 25	2	Bolt	Boulon	Perno
27	6109928M1		1	Boot	Soufflet	Fuelle
28	6109802M91		1	Support Assy	Ensemble de support	Apoyadero, Conj.
29	339009X1	M8 x 35	3	Screw	Vis	Tornillo
30	339374X1	M8	3	Washer, Lock	Rondelle de blocage	Arandela de freno



820 860 880 970 980
 TX760B TX860B
 TX870B TX970B

801 802 803 804 805 806 807 808 813 814 815 816 817 821 822 823 824 825 831
 833 841 843 845 851 853 855 921 922 923 931 932

68003C01.1

6199042M3

1

Jan-06

Loader Controls
Commandes de Chargeur
Mandos de cargadora

Lower Control Levers
Partie Inférieure
Palancas de mando inferiores

7 in 1 Bucket
 7 in 1 Bucket
 7 in 1 Bucket

C-68003-02.1-A

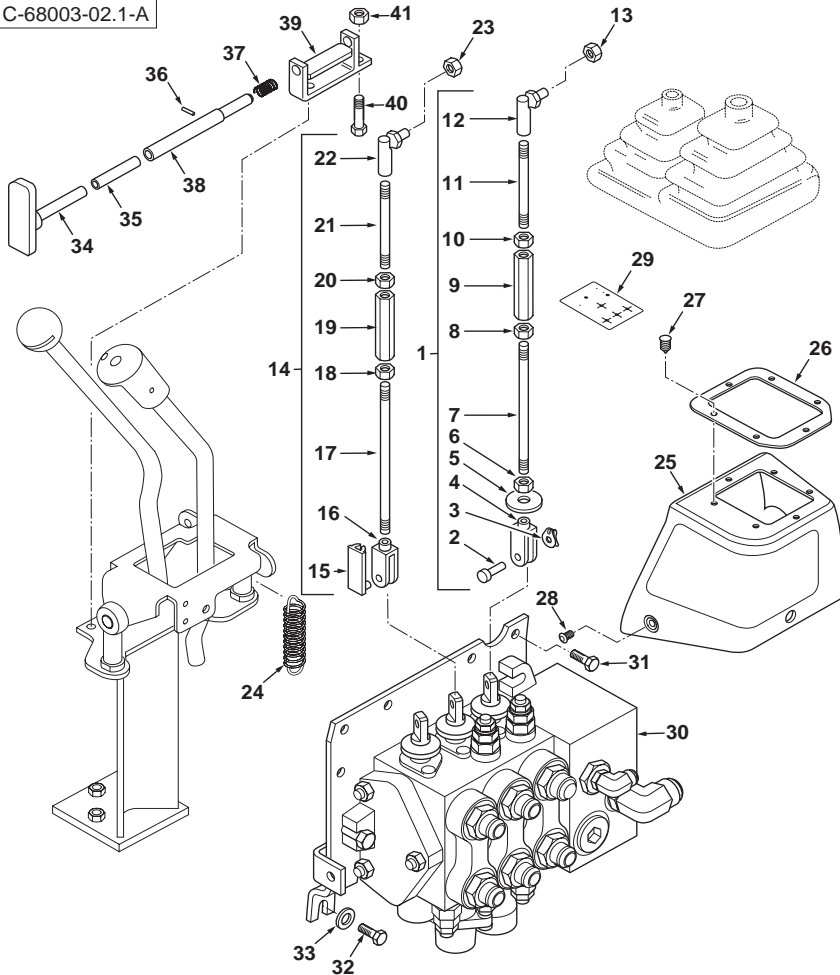

1	6102738M93		1	Rod Assy	Ensemble tringlerie	Tirantes, Conj.
2	6102816M1	1	1	Pin, Clevis	Axe de chape	Eje de brida
3	3516322M1	1	1	Clip	Clip	Clip
4	3519590M1	1	1	LH Thread	Clevis	Chape
5	3518878M3	1	1	Washer	Rondelle	Arandela
6	3519650M1	1	1	M8 LH Thread	Nut	Tuerca
7			1			Tringle
8	339169X1	1	1	M8	Nut	Écrou
9	6102733M1	1	1		Turnbuckle	Tendeur de tringle
10	3519650M1	1	1	M8 LH Thread	Nut	Écrou
11			1			Rod
12	3519589M1	1	1		Ball Joint	Rotule
13	394367X1		1	M8	Nut, Lock	Écrou de blocage
14	6102737M92		2			Rod Assy
15	3520666M1	14	1			Pin, Clevis
16	3519590M1	14	1	LH Thread		Clevis
17			14	➡ Ref. 14		Rod
18	339169X1	14	1	M8		Nut
19	6102733M1	14	1			Turnbuckle
20	3519650M1	14	1	M8 LH Thread		Nut
21			14	➡ Ref. 14		Rod
22	3519589M1	14	1			Ball Joint
23	394367X1		2	M8		Nut, Lock
24	6109761M1		1			Spring
25	6099536M1		1			Console
26	3516856M3		1			Plate
27	3521303M3		6			Fastener
28	3512552M1	M5 x 12	3			Screw
29	6101874M1		1			Decal
30	6109325M91	68003C03.1 1 3 Spool 7:1	1			Valve Assy, Control
31	3009492X1	M10 x 25	2			Screw
32	3009492X1	M10 x 25	1			Screw
33	385362X1	M10	1			Washer
34	6101939M91		1			Handle
35	6101938M1		1			Spacer
36	1441736X1		1			Pin, Roll
37	3516136M2		1			Spring
38	3519365M1		1			Rod
39	6108293M92		1			Bracket Assy
40	339666X1	M6 x 20	2			Screw
41	1441500X1	M6	2			Nut, Lock
42	6101872M1		1			Decal



820 860 880 970 980
 TX760B TX860B
 TX870B TX970B

801 802 803 804 805 806 807 808 813 814 815 816 817 821 822 823 824 825 831
 833 841 843 845 851 853 855 921 922 923 931 932

68003C02.1

6199042M3

1

Jan-06

Loader Controls
Commandes de Chargeur
Mandos de cargadora

Control Valve
Distributeur
Distribuidor

7 in 1 Bucket
 7 in 1 Bucket
 7 in 1 Bucket

C-68003-03.1-A

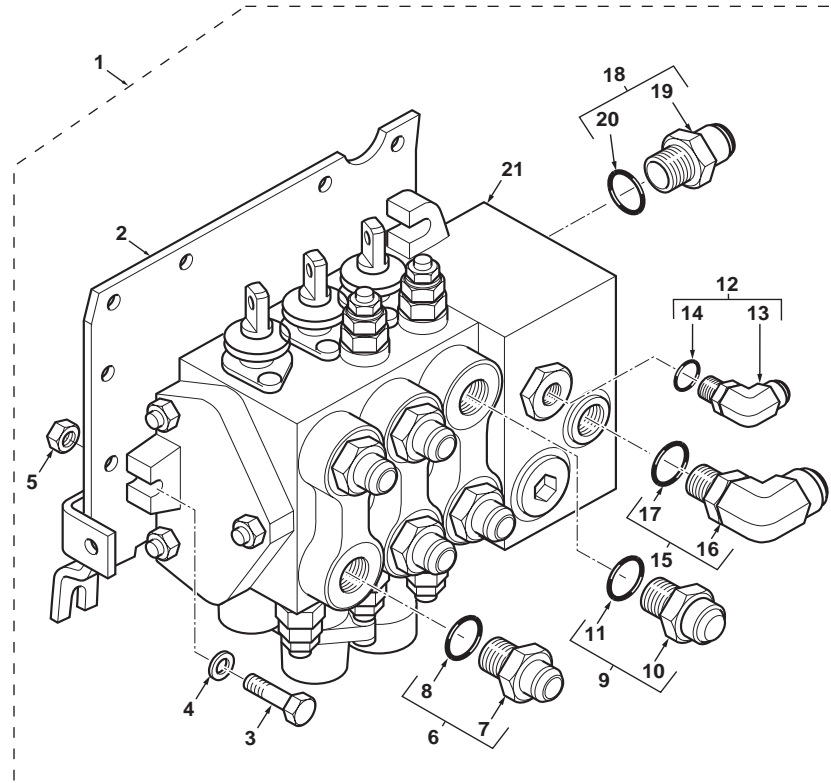

1	6109325M91		3 Spool 7:1	1	Valve Assy, Control	Ensemble distribution	Distribuidor, Conj.
2	6109370M91	1		1	Plate Assy	Ensemble de plaque	Placa, Conj.
3	3009496X1	1	M10 x 45	3	Screw	Vis	Tornillo
4	385362X1	1	M10	3	Washer	Rondelle	Arandela
5	1440329X1	1	M10	3	Nut, Lock	Écrou de blocage	Tuerca de retención
6	365715X91	1	1,1/16" - 7/8" UNF	5	Connector Assy	Ensemble connexion	Conexión, Conj.
7		6	➡ Ref. 6	1	Connector	Connecteur	Conector
8	835025M1	6		1	O-Ring	Joint torique	Junta de tipo O
9	835057M91	1		1	Connector Assy	Ensemble connexion	Conexión, Conj.
10		9	➡ Ref. 9	1	Connector	Connecteur	Conector
11	835025M1	9		1	O-Ring	Joint torique	Junta de tipo O
12	357197X91	1		1	Elbow, 90°	Coude à 90°	Codo, 90°
13		12	➡ Ref. 12	1	Elbow	Coude	Codo
14	831452M1	12		1	O-Ring	Joint torique	Junta de tipo O
15	358764X91	1		1	Elbow, 90°	Coude à 90°	Codo, 90°
16		15	➡ Ref. 15	1	Elbow	Coude	Codo
17	835025M1	15		1	O-Ring	Joint torique	Junta de tipo O
18	835014M91	1		1	Union	Union	Unión
19		18	➡ Ref. 18	1	Connector	Connecteur	Conector
20	835026M1	8		1	O-Ring	Joint torique	Junta de tipo O
21	6109210M91	1	68003C04.1 1 3 Spool	1	Valve Assy, Control	Ensemble distribution	Distribuidor, Conj.



820 860 880 970 980
 TX760B TX860B
 TX870B TX970B

801 802 803 804 805 806 807 808 813 814 815 816 817 821 822 823 824 825 831
 833 841 843 845 851 853 855 921 922 923 931 932

68003C03.1

6199042M3

1

Jan-06

Loader Controls
Commandes de Chargeur
Mandos de cargadora

Upper Control Levers
Partie Supérieure
Palancas de mando superiores

7 in 1 Bucket
 7 in 1 Bucket
 7 in 1 Bucket

C-68004-01.1-A

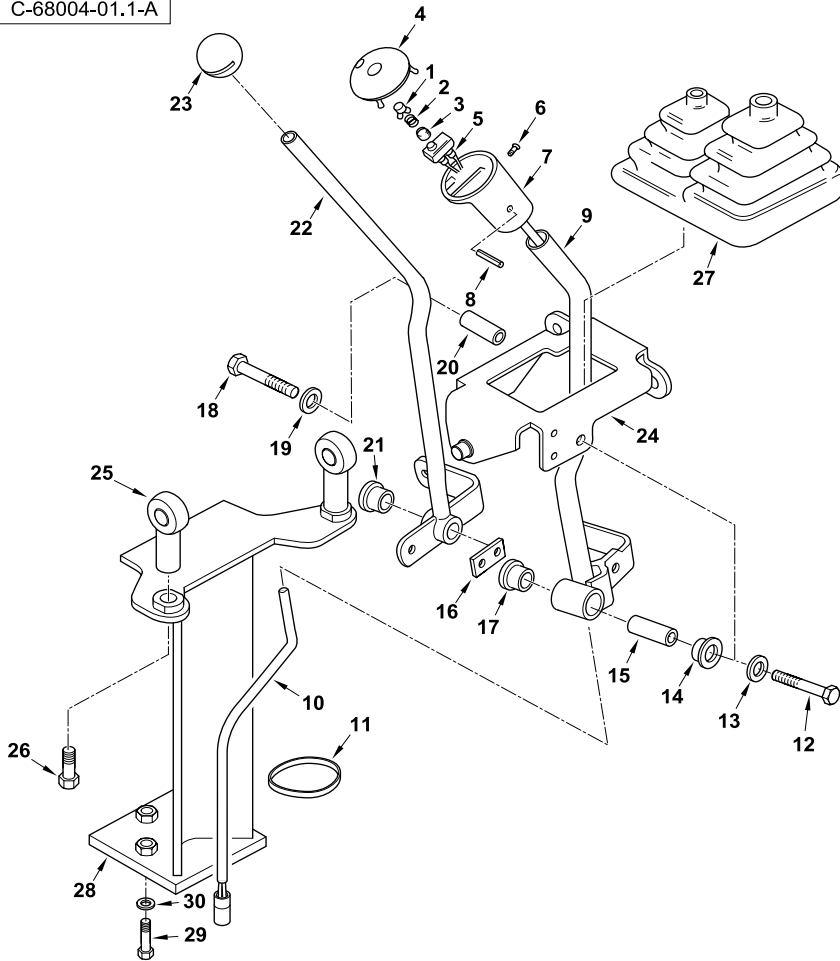

1	3521894M4		2	Button	Bouton	Botón
2	3520328M3		2	Spring	Ressort	Muelle
3	3522894M1		2	Boot	Soufflet	Fuelle
4	3522285M5		1	Knob	Boule	Bola
5	3522507M3		4	Pin	Axe	Pasador
6	3516886M1		2	Screw	Vis	Tornillo
7	3522621M5		1	Grip	Poignée de levier	Empuñ. Palanca
8	3019531X1		1	Pin, Roll	Goupille élastique	Pasador elástico
9	6109383M91		1	Lever Assy	Ensemble de levier	Palanca, Conj.
10	3516043M94		1	Harness	Faisceau	Haz
11	1664405M1		1	Tie, Cable	Attache câble	Enlace de Cable
12	339291X1	M8 x 55	1	Screw	Vis	Tornillo
13	6108769M1	M8	1	Washer, Lock	Rondelle de blocage	Arandela de freno
14	6106560M1		1	Bushing	Bague	Anillo
15	6106561M3		1	Spacer	Entretoise	Traviesa
16	6106562M1		1	Plate	Plaque	Placa
17	6106560M1		1	Bushing	Bague	Anillo
18	339291X1	M8 x 55	1	Screw	Vis	Tornillo
19	6108769M1	M8	1	Washer, Lock	Rondelle de blocage	Arandela de freno
20	6106561M3		1	Spacer	Entretoise	Traviesa
21	6106560M1		2	Bushing	Bague	Anillo
22	6109386M91		1	Lever Assy	Ensemble de levier	Palanca, Conj.
23	3509755M2		1	Knob	Boule	Bola
24	6109381M91		1	Cradle	Berceau	Soporte
25	6102844M1		2	Mount	Support de fixation	Soporte de fijación
26	3009505X1	M12 x 25	2	Bolt	Boulon	Perno
27	6109928M1		1	Boot	Soufflet	Fuelle
28	6109802M91		1	Support Assy	Ensemble de support	Apoyadero, Conj.
29	339009X1	M8 x 35	3	Screw	Vis	Tornillo
30	339374X1	M8	3	Washer, Lock	Rondelle de blocage	Arandela de freno



820 860 880 970 980
 TX760B TX860B
 TX870B TX970B

801 802 803 804 805 806 807 808 809 810 811 812 813 814 815 816 817 821 822
 823 824 825 831 833 841 843 845 851 853 854 855 921 922 923 931 932

68004C01.1

6199042M3

1

Jan-06

Loader Controls
Commandes de Chargeur
Mandos de cargadora

Lower Control Levers
Partie Inférieure
Palancas de mando inferiores

7 in 1 Bucket
 7 in 1 Bucket
 7 in 1 Bucket

C-68004-02.1-A

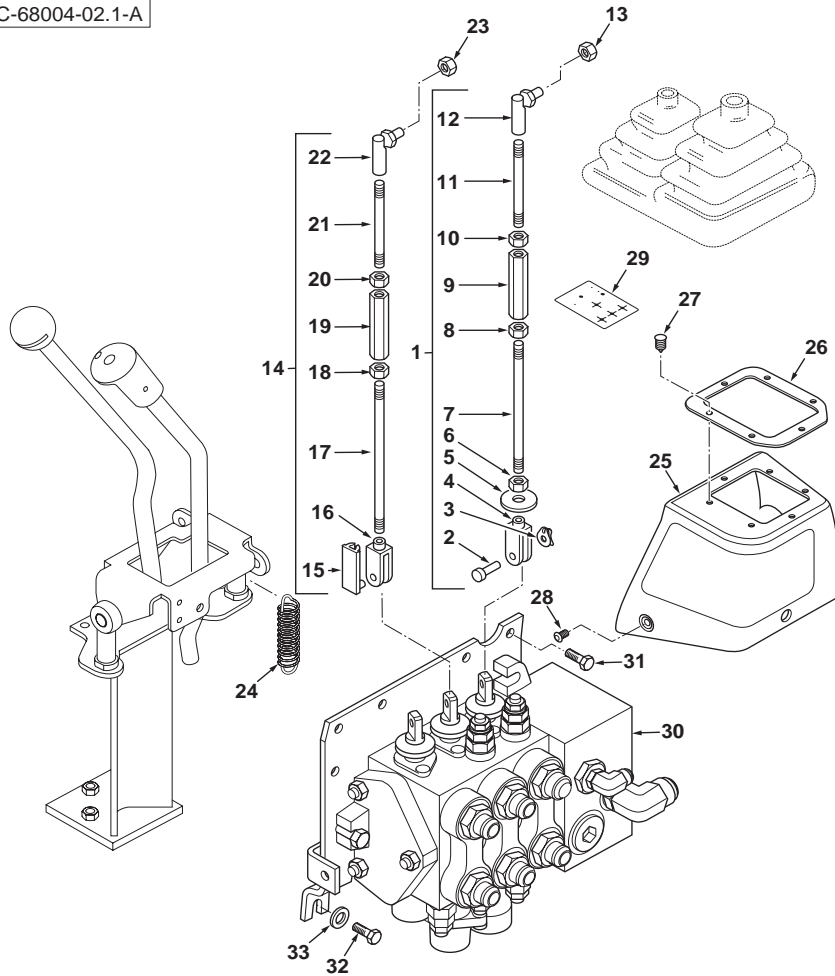

1	6102738M93		1	Rod Assy	Ensemble tringlerie	Tirantes, Conj.	
2	6102816M1	1	1	Pin, Clevis	Axe de chape	Eje de brida	
3	3516322M1	1	1	Clip	Clip	Clip	
4	3519590M1	1	LH Thread	1	Clevis	Chape	Brida
5	3518878M3	1		1	Washer	Rondelle	Arandela
6	3519650M1	1	M8 LH Thread	1	Nut	Écrou	Tuerca
7		1		1	Rod	Tringle	Vástago
8	339169X1	1	M8	1	Nut	Écrou	Tuerca
9	6102733M1	1		1	Turnbuckle	Tendeur de tringle	Torniquete
10	3519650M1	1	M8 LH Thread	1	Nut	Écrou	Tuerca
11		1		1	Rod	Tringle	Vástago
12	3519589M1	1		1	Ball Joint	Rotule	Rotula
13	394367X1		M8	1	Nut, Lock	Écrou de blocage	Tuerca de retención
14	6102737M92			2	Rod Assy	Ensemble tringlerie	Tirantes, Conj.
15	3520666M1	14		1	Pin, Clevis	Axe de chape	Eje de brida
16	3519590M1	14	LH Thread	1	Clevis	Chape	Brida
17		14	➡ Ref. 14	1	Rod	Tringle	Vástago
18	339169X1	14	M8	1	Nut	Écrou	Tuerca
19	6102733M1	14		1	Turnbuckle	Tendeur de tringle	Torniquete
20	3519650M1	14	M8 LH Thread	1	Nut	Écrou	Tuerca
21		14	➡ Ref. 14	1	Rod	Tringle	Vástago
22	3519589M1	14		1	Ball Joint	Rotule	Rotula
23	394367X1		M8	2	Nut, Lock	Écrou de blocage	Tuerca de retención
24	6109761M1			1	Spring	Ressort	Muelle
25	6099522M2			1	Console	Console	Consola
26	3516856M3			1	Plate	Plaque	Placa
27	3521303M3			6	Fastener	Attache	Enganche
28	3512552M1		M5 x 12	3	Screw	Vis	Tornillo
29	6101874M1			1	Decal	Adhésif	Adhesivo
30	6109325M91		68004C03.1 1 3 Spool 7:1	1	Valve Assy, Control	Ensemble distribution	Distribuidor, Conj.
31	3009492X1		M10 x 25	2	Screw	Vis	Tornillo
32	3009492X1		M10 x 25	1	Screw	Vis	Tornillo
33	385362X1		M10	1	Washer	Rondelle	Arandela



820 860 880 970 980
 TX760B TX860B
 TX870B TX970B

801 802 803 804 805 806 807 808 809 810 811 812 813 814 815 816 817 821 822
 823 824 825 831 833 841 843 845 851 853 854 855 921 922 923 931 932

68004C02.1

6199042M3

1

Jan-06

Loader Controls
Commandes de Chargeur
Mandos de cargadora

Control Valve
Distributeur
Distribuidor

7 in 1 Bucket
 7 in 1 Bucket
 7 in 1 Bucket

C-68004-03.1-A

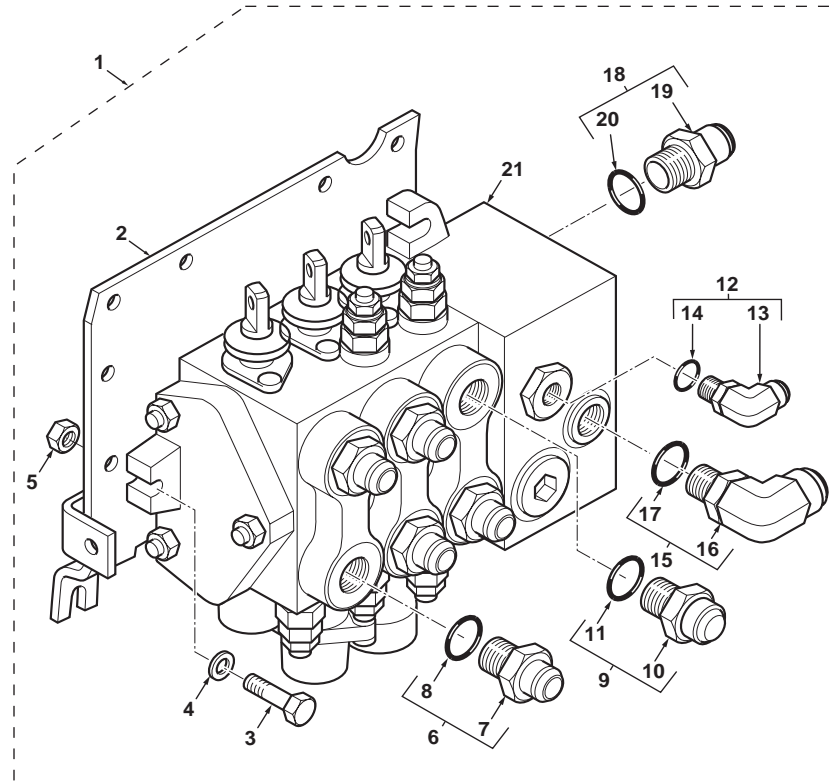

1	6109325M91		3 Spool 7:1	1	Valve Assy, Control	Ensemble distribution	Distribuidor, Conj.
2	6109370M91	1		1	Plate Assy	Ensemble de plaque	Placa, Conj.
3	3009496X1	1	M10 x 45	3	Screw	Vis	Tornillo
4	385362X1	1	M10	3	Washer	Rondelle	Arandela
5	1440329X1	1	M10	3	Nut, Lock	Écrou de blocage	Tuerca de retención
6	365715X91	1	1,1/16" - 7/8" UNF	5	Connector Assy	Ensemble connexion	Conexión, Conj.
7		6	➡ Ref. 6	1	Connector	Connecteur	Conector
8	835025M1	6		1	O-Ring	Joint torique	Junta de tipo O
9	835057M91	1		1	Connector Assy	Ensemble connexion	Conexión, Conj.
10		9	➡ Ref. 9	1	Connector	Connecteur	Conector
11	835025M1	9		1	O-Ring	Joint torique	Junta de tipo O
12	357197X91	1		1	Elbow, 90°	Coude à 90°	Codo, 90°
13		12	➡ Ref. 12	1	Elbow	Coude	Codo
14	831452M1	12		1	O-Ring	Joint torique	Junta de tipo O
15	358764X91	1		1	Elbow, 90°	Coude à 90°	Codo, 90°
16		15	➡ Ref. 15	1	Elbow	Coude	Codo
17	835025M1	15		1	O-Ring	Joint torique	Junta de tipo O
18	835014M91	1		1	Union	Union	Unión
19		18	➡ Ref. 18	1	Connector	Connecteur	Conector
20	835026M1	8		1	O-Ring	Joint torique	Junta de tipo O
21	6109210M91	1	68004C04.1 1 3 Spool	1	Valve Assy, Control	Ensemble distribution	Distribuidor, Conj.



820 860 880 970 980
 TX760B TX860B
 TX870B TX970B

801 802 803 804 805 806 807 808 809 810 811 812 813 814 815 816 817 821 822
 823 824 825 831 833 841 843 845 851 853 854 855 921 922 923 931 932

68004C03.1

6199042M3

1

Jan-06

Loader Controls
Commandes de Chargeur
Mandos de cargadora

Upper Control Levers
Partie Supérieure
Palancas de mando superiores

C-68006-01.1-A

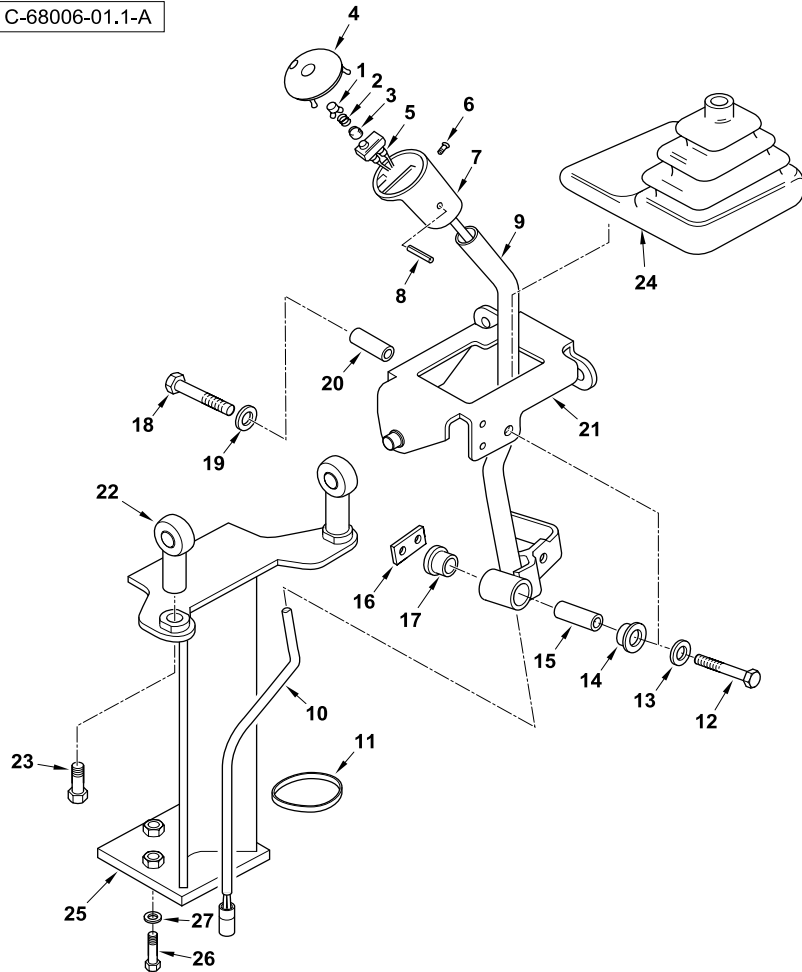

1	3521894M4		2	Button	Bouton	Botón
2	3520328M3		2	Spring	Ressort	Muelle
3	3522894M1		2	Boot	Soufflet	Fuelle
4	3522285M5		1	Knob	Boule	Bola
5	3522507M3		4	Pin	Axe	Pasador
6	3516886M1		2	Screw	Vis	Tornillo
7	3522621M5		1	Grip	Poignée de levier	Empuñ. Palanca
8	3019531X1		1	Pin, Roll	Goupille élastique	Pasador elástico
9	6109383M91		1	Lever Assy	Ensemble de levier	Palanca, Conj.
10	3516043M94		1	Harness	Faisceau	Haz
11	1664405M1		1	Tie, Cable	Attache câble	Enlace de Cable
12	339291X1	M8 x 55	1	Screw	Vis	Tornillo
13	6108769M1	M8	1	Washer, Lock	Rondelle de blocage	Arandela de freno
14	6106560M1		1	Bushing	Bague	Anillo
15	6106561M3		1	Spacer	Entretoise	Traviesa
16	6106562M1		1	Plate	Plaque	Placa
17	6106560M1		1	Bushing	Bague	Anillo
18	339291X1	M8 x 55	1	Screw	Vis	Tornillo
19	6108769M1	M8	1	Washer, Lock	Rondelle de blocage	Arandela de freno
20	6106561M3		1	Spacer	Entretoise	Traviesa
21	6109381M91		1	Cradle	Berceau	Soporte
22	6102844M1		2	Mount	Support de fixation	Soporte de fijación
23	3009505X1	M12 x 25	2	Bolt	Boulon	Perno
24	6109802M91		1	Support Assy	Ensemble de support	Apoyadero, Conj.
25	6109927M1		1	Boot	Soufflet	Fuelle
26	339009X1	M8 x 35	3	Screw	Vis	Tornillo
27	339374X1	M8	3	Washer, Lock	Rondelle de blocage	Arandela de freno



820 860 880 970 980
 TX760B TX860B
 TX870B TX970B

801 802 803 804 805 806 807 808 813 814 815 816 817 821 822 823 824 825 831
 833 841 843 845 851 853 855 921 922 923 931 932

68006C01.1

6199042M3

1

Jan-06

Loader Controls
Commandes de Chargeur
Mandos de cargadora

Lower Control Levers
Partie Inférieure
Palancas de mando inferiores

C-68006-02.1-B

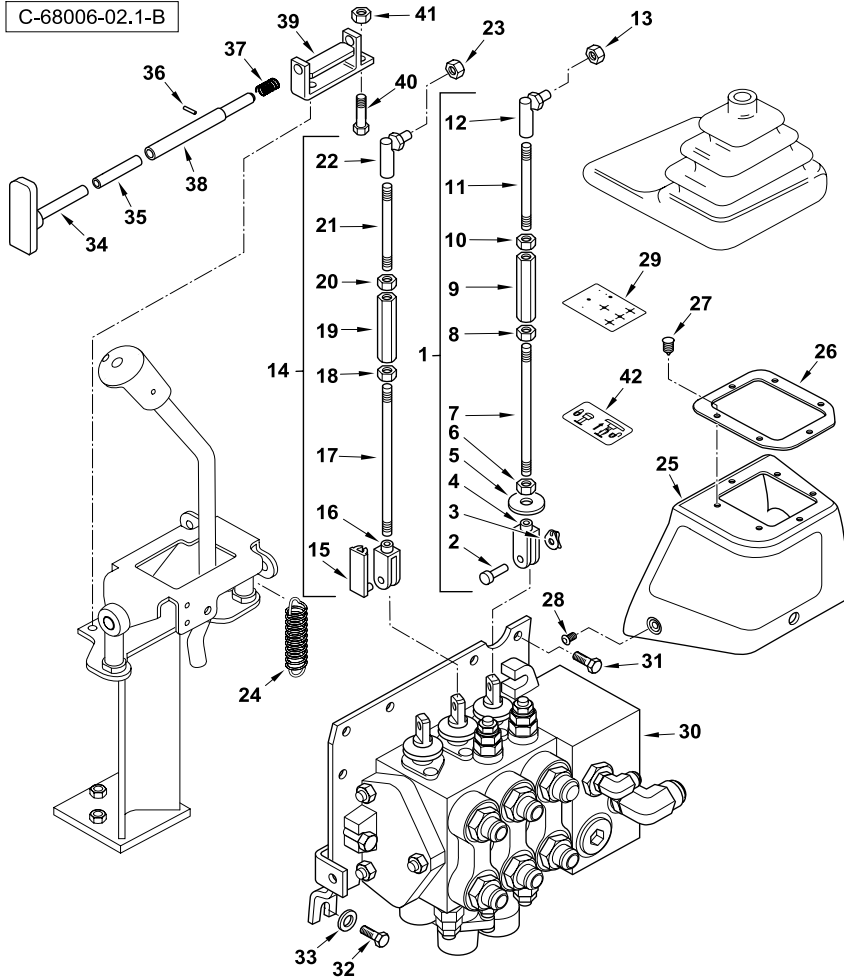

1	6102738M93		1	Rod Assy	Ensemble tringlerie	Tirantes, Conj.
2	6102816M1	1	1	Pin, Clevis	Axe de chape	Eje de brida
3	3516322M1	1	1	Clip	Clip	Clip
4	3519590M1	1	1	LH Thread	Clevis	Chape
5	3518878M3	1	1	Washer	Rondelle	Arandela
6	3519650M1	1	1	M8 LH Thread	Nut	Tuerca
7		1	1	Ref. 1	Rod	Tringle
8	339169X1	1	1	M8	Nut	Écrou
9	6102733M1	1	1	Turnbuckle	Tendeur de tringle	Torniquete
10	3519650M1	1	1	M8 LH Thread	Nut	Écrou
11		1	1	Ref. 1	Rod	Vástago
12	3519589M1	1	1	Ball Joint	Rotule	Rotula
13	394367X1		1	M8	Nut, Lock	Écrou de blocage
14	6102737M92		1	Rod Assy	Ensemble tringlerie	Tirantes, Conj.
15	3520666M1	14	1	Pin, Clevis	Axe de chape	Eje de brida
16	3519590M1	14	1	LH Thread	Clevis	Chape
17		14	1	Ref. 14	Rod	Vástago
18	339169X1	14	1	M8	Nut	Écrou
19	6102733M1	14	1	Turnbuckle	Tendeur de tringle	Torniquete
20	3519650M1	14	1	M8 LH Thread	Nut	Écrou
21		14	1	Ref. 14	Rod	Vástago
22	3519589M1	14	1	Ball Joint	Rotule	Rotula
23	394367X1		1	M8	Nut, Lock	Écrou de blocage
24	6109761M1		1	Spring	Ressort	Muelle
25	6099536M1		1	Console	Console	Consola
26	3516856M3		1	Plate	Plaque	Placa
27	3521303M3		6	Fastener	Attache	Enganche
28	3512552M1	M5 x 12	3	Screw	Vis	Tornillo
29	6101873M1		1	Decal	Adhésif	Adhesivo
30	6109325M91	68006C03.1 1 3 Spool 7:1	1	Valve Assy, Control	Ensemble distribution	Distribuidor, Conj.
31	3009492X1	M10 x 25	2	Screw	Vis	Tornillo
32	3009492X1	M10 x 25	1	Screw	Vis	Tornillo
33	385362X1	M10	1	Washer	Rondelle	Arandela
34	6101939M91		1	Handle	Poignée	Asa
35	6101938M1		1	Spacer	Entretoise	Traviesa
36	1441736X1		1	Pin, Roll	Goupille élastique	Pasador elástico
37	3516136M2		1	Spring	Ressort	Muelle
38	3519365M1		1	Rod	Tringle	Vástago
39	6108293M92		1	Bracket Assy	Ensemble chaise palier	Cuchara, Conj.
40	339666X1	M6 x 20	2	Screw	Vis	Tornillo
41	1441500X1	M6	2	Nut, Lock	Écrou de blocage	Tuerca de retención
42	6101872M1		1	Decal	Adhésif	Adhesivo



820 860 880 970 980
 TX760B TX860B
 TX870B TX970B

801 802 803 804 805 806 807 808 813 814 815 816 817 821 822 823 824 825 831
 833 841 843 845 851 853 855 921 922 923 931 932

68006C02.1

6199042M3

1

Jan-06

Loader Controls
Commandes de Chargeur
Mandos de cargadora

Control Valve
Distributeur
Distribuidor

C-68006-03.1-A

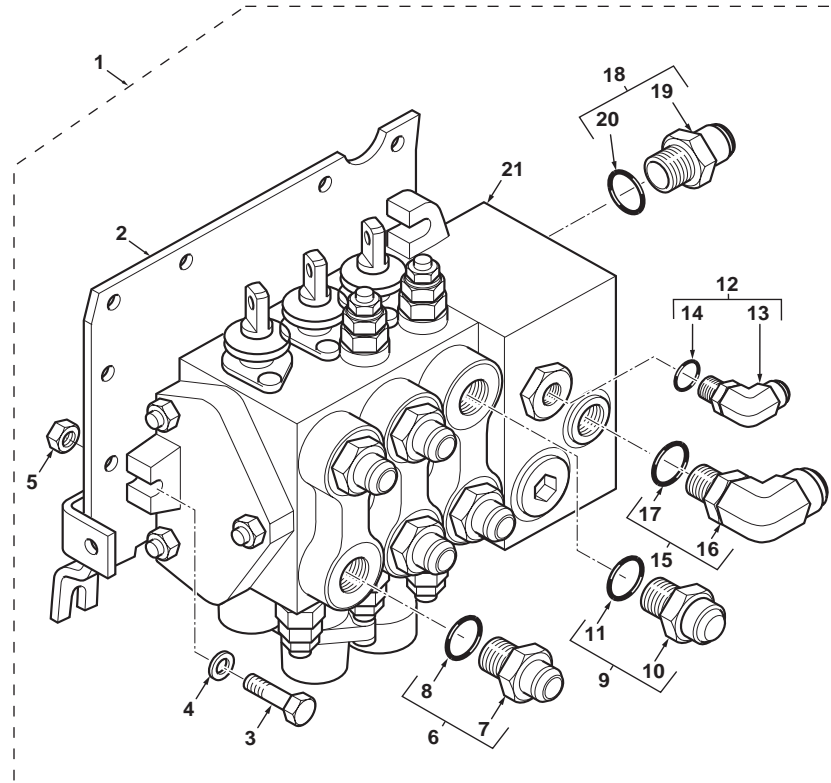

1	6109325M91		3 Spool 7:1	1	Valve Assy, Control	Ensemble distribution	Distribuidor, Conj.
2	6109370M91	1		1	Plate Assy	Ensemble de plaque	Placa, Conj.
3	3009496X1	1	M10 x 45	3	Screw	Vis	Tornillo
4	385362X1	1	M10	3	Washer	Rondelle	Arandela
5	1440329X1	1	M10	3	Nut, Lock	Écrou de blocage	Tuerca de retención
6	365715X91	1	1,1/16" - 7/8" UNF	5	Connector Assy	Ensemble connexion	Conexión, Conj.
7		6	➡ Ref. 6	1	Connector	Connecteur	Conector
8	835025M1	6		1	O-Ring	Joint torique	Junta de tipo O
9	835057M91	1		1	Connector Assy	Ensemble connexion	Conexión, Conj.
10		9	➡ Ref. 9	1	Connector	Connecteur	Conector
11	835025M1	9		1	O-Ring	Joint torique	Junta de tipo O
12	357197X91	1		1	Elbow, 90°	Coude à 90°	Codo, 90°
13		12	➡ Ref. 12	1	Elbow	Coude	Codo
14	831452M1	12		1	O-Ring	Joint torique	Junta de tipo O
15	358764X91	1		1	Elbow, 90°	Coude à 90°	Codo, 90°
16		15	➡ Ref. 15	1	Elbow	Coude	Codo
17	835025M1	15		1	O-Ring	Joint torique	Junta de tipo O
18	835014M91	1		1	Union	Union	Unión
19		18	➡ Ref. 18	1	Connector	Connecteur	Conector
20	835026M1	8		1	O-Ring	Joint torique	Junta de tipo O
21	6109210M91	1	68006C04.1 1 3 Spool	1	Valve Assy, Control	Ensemble distribution	Distribuidor, Conj.



820 860 880 970 980
 TX760B TX860B
 TX870B TX970B

801 802 803 804 805 806 807 808 813 814 815 816 817 821 822 823 824 825 831
 833 841 843 845 851 853 855 921 922 923 931 932

68006C03.1

6199042M3

1

Jan-06

Loader Controls
Commandes de Chargeur
Mandos de cargadora

Upper Control Levers
Partie Supérieure
Palancas de mando superiores

C-68007-01.1-A

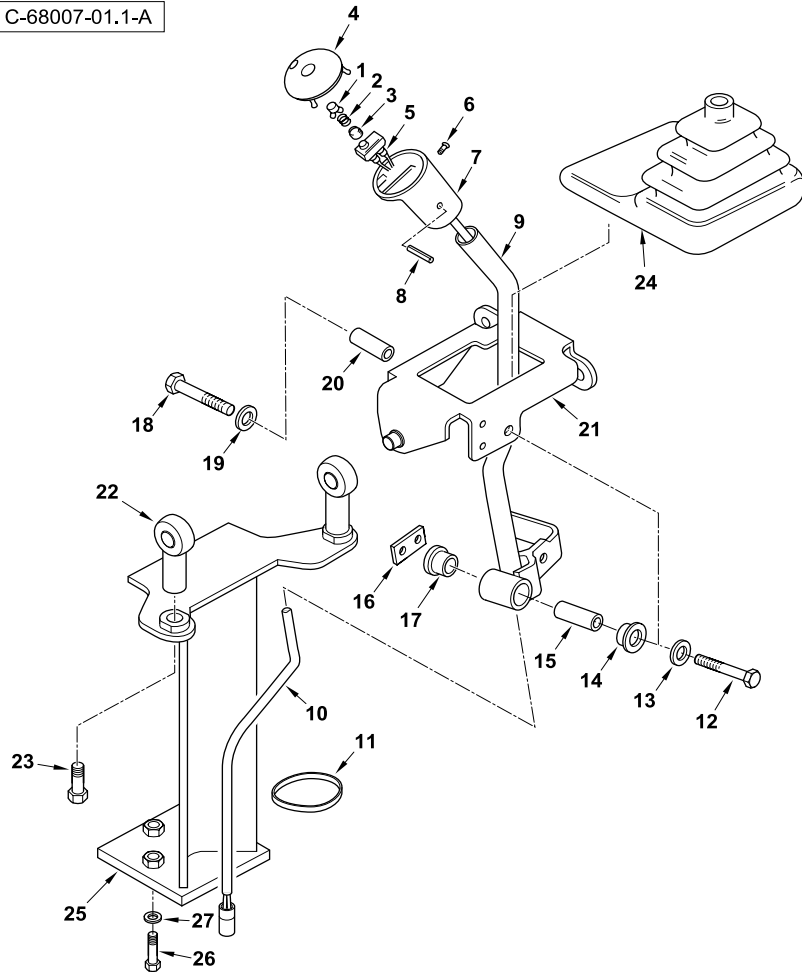

1	3521894M4		2	Button	Bouton	Botón
2	3520328M3		2	Spring	Ressort	Muelle
3	3522894M1		2	Boot	Soufflet	Fuelle
4	3522285M5		1	Knob	Boule	Bola
5	3522507M3		4	Pin	Axe	Pasador
6	3516886M1		2	Screw	Vis	Tornillo
7	3522621M5		1	Grip	Poignée de levier	Empuñ. Palanca
8	3019531X1		1	Pin, Roll	Goupille élastique	Pasador elástico
9	6109383M91		1	Lever Assy	Ensemble de levier	Palanca, Conj.
10	3516043M94		1	Harness	Faisceau	Haz
11	1664405M1		1	Tie, Cable	Attache câble	Enlace de Cable
12	339291X1	M8 x 55	1	Screw	Vis	Tornillo
13	6108769M1	M8	1	Washer, Lock	Rondelle de blocage	Arandela de freno
14	6106560M1		1	Bushing	Bague	Anillo
15	6106561M3		1	Spacer	Entretoise	Traviesa
16	6106562M1		1	Plate	Plaque	Placa
17	6106560M1		1	Bushing	Bague	Anillo
18	339291X1	M8 x 55	1	Screw	Vis	Tornillo
19	6108769M1	M8	1	Washer, Lock	Rondelle de blocage	Arandela de freno
20	6106561M3		1	Spacer	Entretoise	Traviesa
21	6109381M91		1	Cradle	Berceau	Soporte
22	6102844M1		2	Mount	Support de fixation	Soporte de fijación
23	3009505X1	M12 x 25	2	Bolt	Boulon	Perno
24	6109802M91		1	Support Assy	Ensemble de support	Apoyadero, Conj.
25	6109927M1		1	Boot	Soufflet	Fuelle
26	339009X1	M8 x 35	3	Screw	Vis	Tornillo
27	339374X1	M8	3	Washer, Lock	Rondelle de blocage	Arandela de freno



820 860 880 970 980
 TX760B TX860B
 TX870B TX970B

801 802 803 804 805 806 807 808 809 810 811 812 813 814 815 816 817 821 822
 823 824 825 831 833 841 843 845 851 853 855 921 922 923 931 932

68007C01.1

6199042M3

1

Jan-06

Loader Controls
Commandes de Chargeur
Mandos de cargadora

Lower Control Levers
Partie Inférieure
Palancas de mando inferiores

C-68007-02.1-A

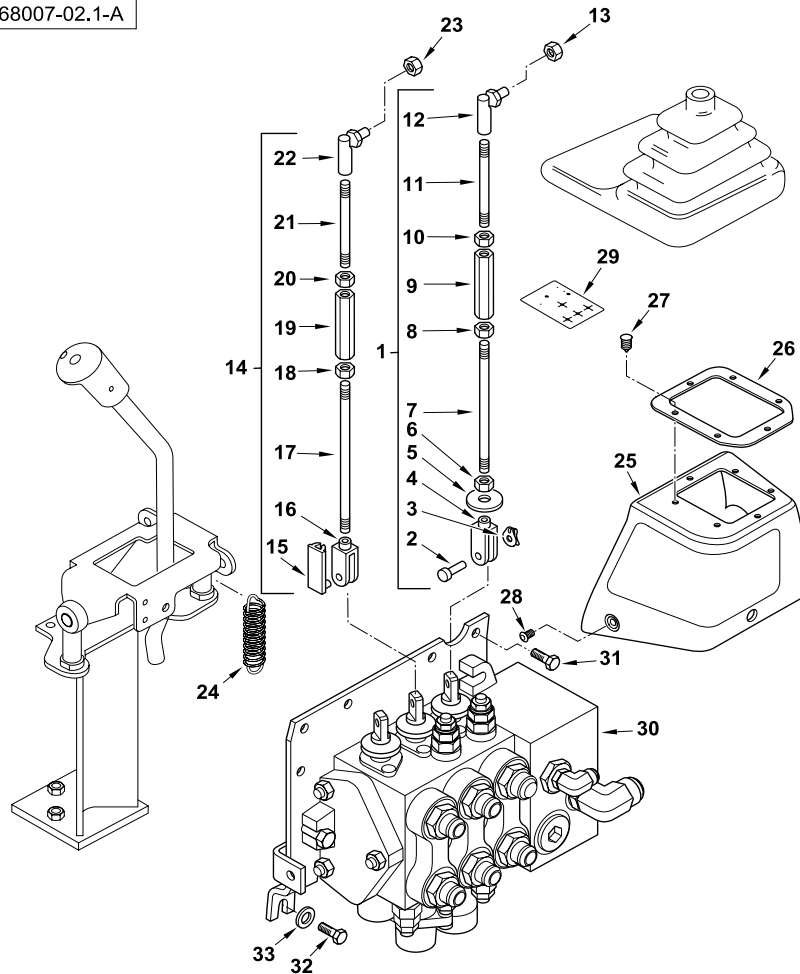

1	6102738M93		1	Rod Assy	Ensemble tringlerie	Tirantes, Conj.
2	6102816M1	1	1	Pin, Clevis	Axe de chape	Eje de brida
3	3516322M1	1	1	Clip	Clip	Clip
4	3519590M1	1	LH Thread	Clevis	Chape	Brida
5	3518878M3	1		Washer	Rondelle	Arandela
6	3519650M1	1	M8 LH Thread	Nut	Écrou	Tuerca
7		1		Rod	Tringle	Vástago
8	339169X1	1	M8	Nut	Écrou	Tuerca
9	6102733M1	1		Turnbuckle	Tendeur de tringle	Torniquete
10	3519650M1	1	M8 LH Thread	Nut	Écrou	Tuerca
11		1		Rod	Tringle	Vástago
12	3519589M1	1		Ball Joint	Rotule	Rotula
13	394367X1		M8	Nut, Lock	Écrou de blocage	Tuerca de retención
14	6102737M92			Rod Assy	Ensemble tringlerie	Tirantes, Conj.
15	3520666M1	14		Pin, Clevis	Axe de chape	Eje de brida
16	3519590M1	14	LH Thread	Clevis	Chape	Brida
17		14	➡ Ref. 14	Rod	Tringle	Vástago
18	339169X1	14	M8	Nut	Écrou	Tuerca
19	6102733M1	14		Turnbuckle	Tendeur de tringle	Torniquete
20	3519650M1	14	M8 LH Thread	Nut	Écrou	Tuerca
21		14	➡ Ref. 14	Rod	Tringle	Vástago
22	3519589M1	14		Ball Joint	Rotule	Rotula
23	394367X1		M8	Nut, Lock	Écrou de blocage	Tuerca de retención
24	6109761M1			Spring	Ressort	Muelle
25	6099522M2			Console	Console	Consola
26	3516856M3			Plate	Plaque	Placa
27	3521303M3			Fastener	Attache	Enganche
28	3512552M1		M5 x 12	Screw	Vis	Tornillo
29	6101873M1			Decal	Adhésif	Adhesivo
30	6109325M91		68004C03.1 1 3 Spool 7:1	Valve Assy, Control	Ensemble distribution	Distribuidor, Conj.
31	3009492X1		M10 x 25	Screw	Vis	Tornillo
32	3009492X1		M10 x 25	Screw	Vis	Tornillo
33	385362X1		M10	Washer	Rondelle	Arandela



820 860 880 970 980
 TX760B TX860B
 TX870B TX970B

801 802 803 804 805 806 807 808 809 810 811 812 813 814 815 816 817 821 822
 823 824 825 831 833 841 843 845 851 853 855 921 922 923 931 932

68007C02.1

6199042M3

1

Jan-06

Loader Controls
Commandes de Chargeur
Mandos de cargadora

Control Valve
Distributeur
Distribuidor

C-68007-03.1-A

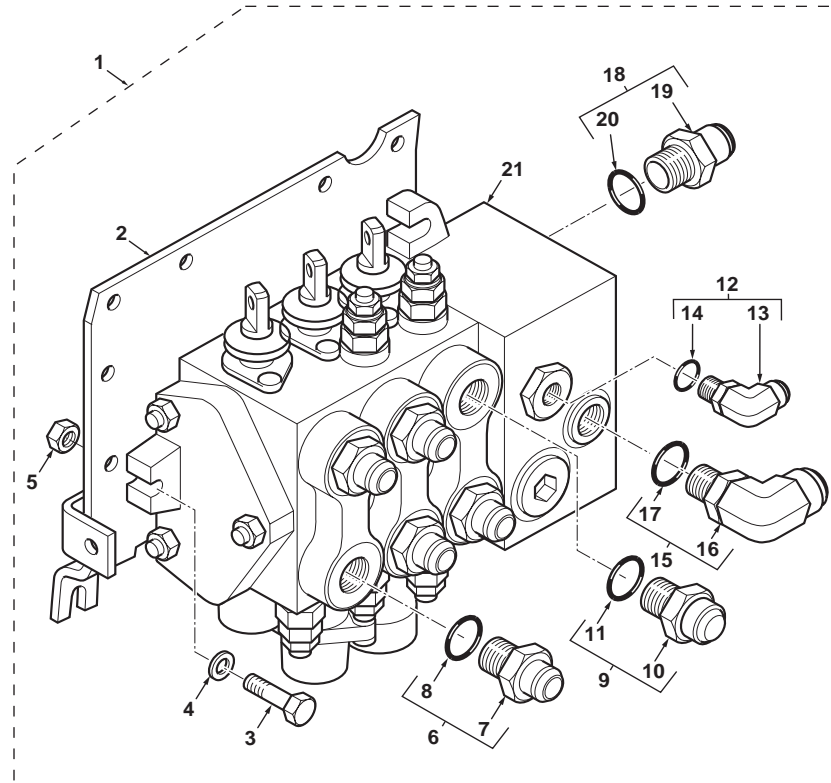

1	6109325M91		3 Spool 7:1	1	Valve Assy, Control	Ensemble distribution	Distribuidor, Conj.
2	6109370M91	1		1	Plate Assy	Ensemble de plaque	Placa, Conj.
3	3009496X1	1	M10 x 45	3	Screw	Vis	Tornillo
4	385362X1	1	M10	3	Washer	Rondelle	Arandela
5	1440329X1	1	M10	3	Nut, Lock	Écrou de blocage	Tuerca de retención
6	365715X91	1	1,1/16" - 7/8" UNF	5	Connector Assy	Ensemble connexion	Conexión, Conj.
7		6	➡ Ref. 6	1	Connector	Connecteur	Conector
8	835025M1	6		1	O-Ring	Joint torique	Junta de tipo O
9	835057M91	1		1	Connector Assy	Ensemble connexion	Conexión, Conj.
10		9	➡ Ref. 9	1	Connector	Connecteur	Conector
11	835025M1	9		1	O-Ring	Joint torique	Junta de tipo O
12	357197X91	1		1	Elbow, 90°	Coude à 90°	Codo, 90°
13		12	➡ Ref. 12	1	Elbow	Coude	Codo
14	831452M1	12		1	O-Ring	Joint torique	Junta de tipo O
15	358764X91	1		1	Elbow, 90°	Coude à 90°	Codo, 90°
16		15	➡ Ref. 15	1	Elbow	Coude	Codo
17	835025M1	15		1	O-Ring	Joint torique	Junta de tipo O
18	835014M91	1		1	Union	Union	Unión
19		18	➡ Ref. 18	1	Connector	Connecteur	Conector
20	835026M1	18		1	O-Ring	Joint torique	Junta de tipo O
21	6109210M91	1	68004C04.1 1 3 Spool	1	Valve Assy, Control	Ensemble distribution	Distribuidor, Conj.



820 860 880 970 980
 TX760B TX860B
 TX870B TX970B

801 802 803 804 805 806 807 808 809 810 811 812 813 814 815 816 817 821 822
 823 824 825 831 833 841 843 845 851 853 855 921 922 923 931 932

68007C03.1

6199042M3

1

Jan-06

Loader Controls
Commandes de Chargeur
Mandos de cargadora

Control Valve
Distributeur
Distribuidor

7 in 1 Bucket
Benne 7 en 1
Benna 7 in 1

Servo
Servo
Servo

C-68008-03.1-A

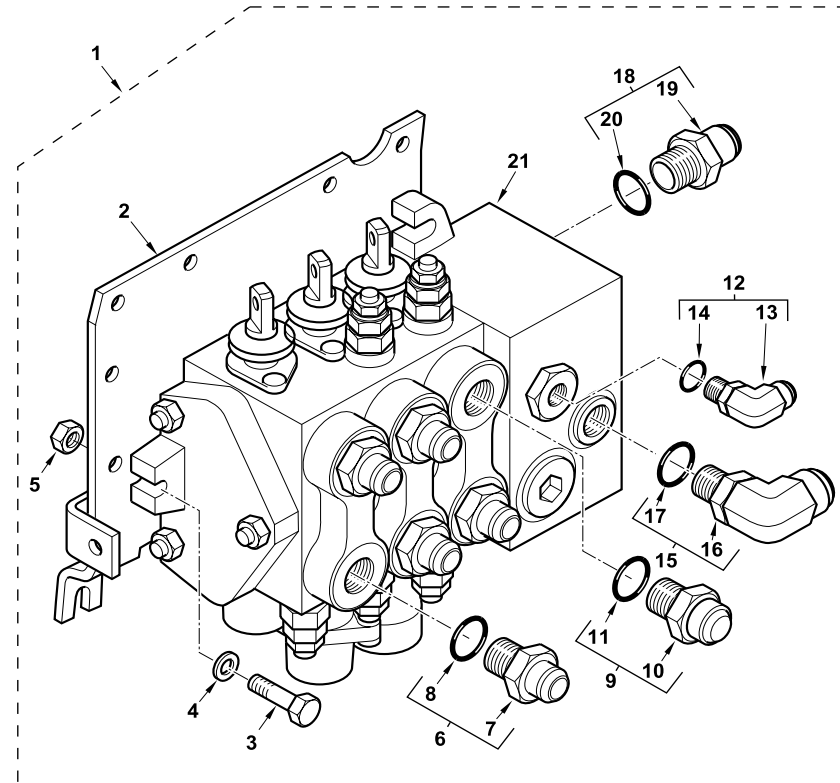

1	6109325M91		3 Spool 7:1	1	Valve Assy, Control	Ensemble distribution	Distribuidor, Conj.
2	6109370M91	1		1	Plate Assy	Ensemble de plaque	Placa, Conj.
3	3009496X1	1	M10 x 45	3	Screw	Vis	Tornillo
4	385362X1	1	M10	3	Washer	Rondelle	Arandela
5	1440329X1	1	M10	3	Nut, Lock	Écrou de blocage	Tuerca de retención
6	365715X91	1	1,1/16" - 7/8" UNF	5	Connector Assy	Ensemble connexion	Conexión, Conj.
7		6	➡ Ref. 6	1	Connector	Connecteur	Conector
8	835025M1	6		1	O-Ring	Joint torique	Junta de tipo O
9	835057M91	1		1	Connector Assy	Ensemble connexion	Conexión, Conj.
10		9	➡ Ref. 9	1	Connector	Connecteur	Conector
11	835025M1	9		1	O-Ring	Joint torique	Junta de tipo O
12	357197X91	1		1	Elbow, 90°	Coude à 90°	Codo, 90°
13		12	➡ Ref. 12	1	Elbow	Coude	Codo
14	831452M1	12		1	O-Ring	Joint torique	Junta de tipo O
15	358764X91	1		1	Elbow, 90°	Coude à 90°	Codo, 90°
16		15	➡ Ref. 15	1	Elbow	Coude	Codo
17	835025M1	15		1	O-Ring	Joint torique	Junta de tipo O
18	835014M91	1		1	Union	Union	Unión
19		18	➡ Ref. 18	1	Connector	Connecteur	Conector
20	835026M1	8		1	O-Ring	Joint torique	Junta de tipo O
21	6109210M91	1	👁 [68008C04.1 1] 3 Spool	1	Valve Assy, Control	Ensemble distribution	Distribuidor, Conj.



880
TX760B TX860B
TX870B

832 834 842 844 852 854

68008C03.1

6199042M3

1

Jan-06

Loader Controls
Commandes de Chargeur
Mandos de cargadora

Control Valve
Distributeur
Distribuidor

Servo
Servo
Servo

C-68009-03.1-A

1	6109325M91		3 Spool 7:1	1	Valve Assy, Control	Ensemble distribution	Distribuidor, Conj.
2	6109370M91	1		1	Plate Assy	Ensemble de plaque	Placa, Conj.
3	3009496X1	1	M10 x 45	3	Screw	Vis	Tornillo
4	385362X1	1	M10	3	Washer	Rondelle	Arandela
5	1440329X1	1	M10	3	Nut, Lock	Écrou de blocage	Tuerca de retención
6	365715X91	1	1,1/16" - 7/8" UNF	5	Connector Assy	Ensemble connexion	Conexión, Conj.
7		6	➡ Ref. 6	1	Connector	Connecteur	Conector
8	835025M1	6		1	O-Ring	Joint torique	Junta de tipo O
9	835057M91	1		1	Connector Assy	Ensemble connexion	Conexión, Conj.
10		9	➡ Ref. 9	1	Connector	Connecteur	Conector
11	835025M1	9		1	O-Ring	Joint torique	Junta de tipo O
12	357197X91	1		1	Elbow, 90°	Coude à 90°	Codo, 90°
13		12	➡ Ref. 12	1	Elbow	Coude	Codo
14	831452M1	12		1	O-Ring	Joint torique	Junta de tipo O
15	358764X91	1		1	Elbow, 90°	Coude à 90°	Codo, 90°
16		15	➡ Ref. 15	1	Elbow	Coude	Codo
17	835025M1	15		1	O-Ring	Joint torique	Junta de tipo O
18	835014M91	1		1	Union	Union	Unión
19		18	➡ Ref. 18	1	Connector	Connecteur	Conector
20	835026M1	18		1	O-Ring	Joint torique	Junta de tipo O
21	6109210M91	1	👁 [68009C04.1 1] 3 Spool	1	Valve Assy, Control	Ensemble distribution	Distribuidor, Conj.

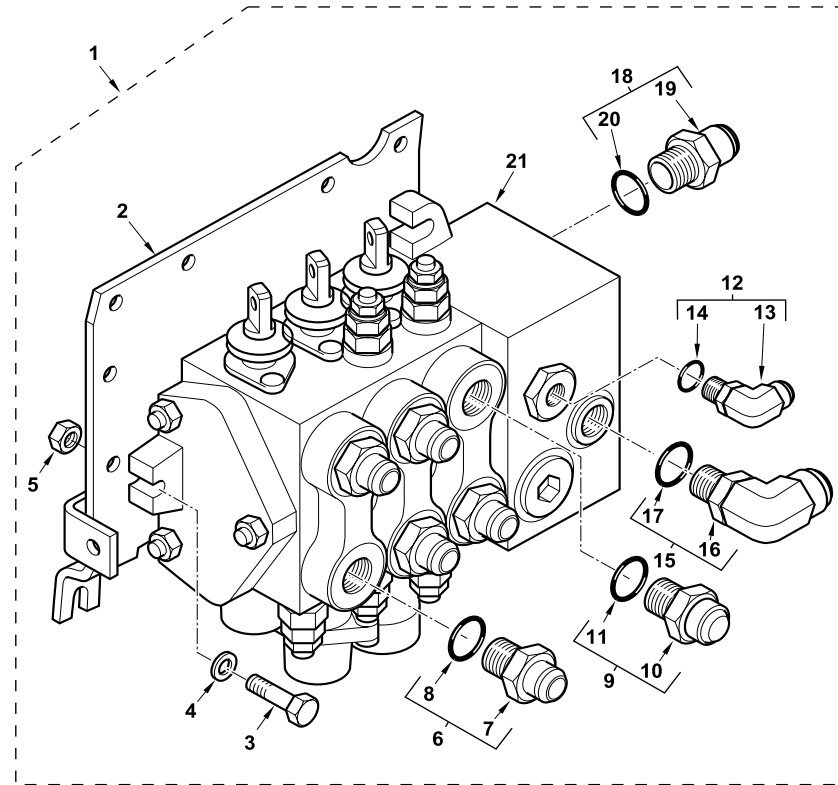

880
TX760B TX860B
TX870B

832 834 842 844 852 854

68009C03.1

6199042M3

1

Jan-06

Loader Controls
Commandes de Chargeur
Mandos de cargadora

Hydraulic Valve
Distributeur de Commande Hydraulique
Distribuidor de mando hidráulico

Inlet
Admission
Admision

7 in 1 Bucket
7 in 1 Bucket
7 in 1 Bucket

C-68003-04.1-A

1	6109210M91	3 Spool	1	Valve Assy, Control	Ensemble distribution	Distribuidor, Conj.
2	6194535M91	Inlet	1	Element - Inlet		
3	6193771M91	Interface	1	Kit, Seal	Pochette de joints	Juego de juntas

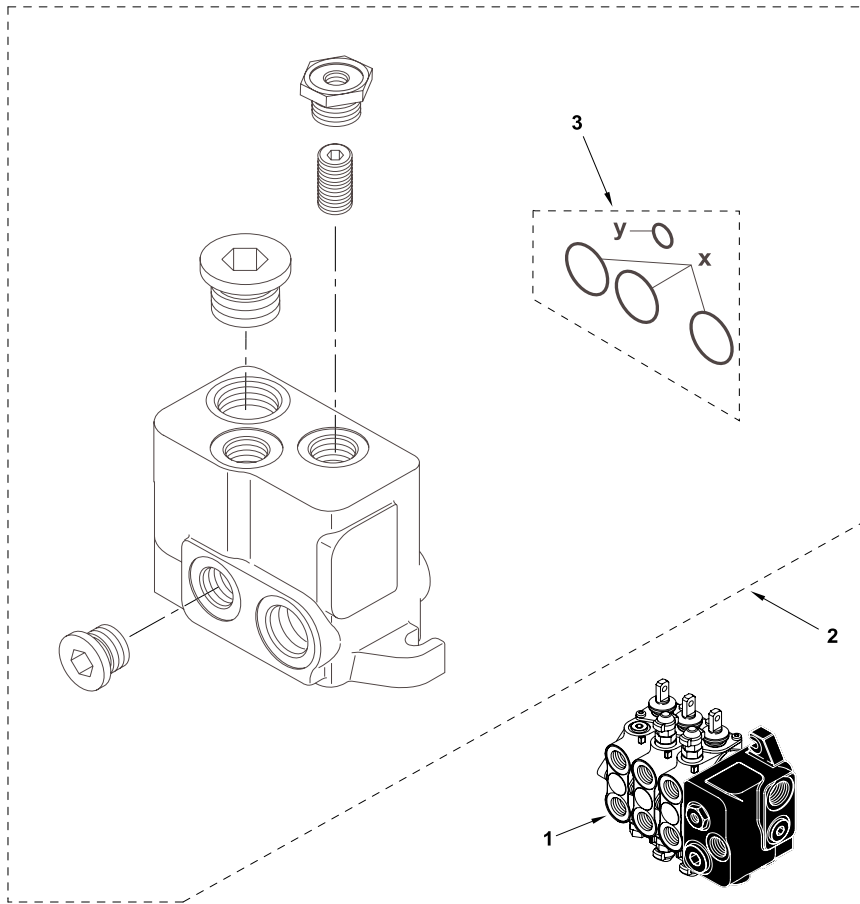

820 860 880 970 980
TX760B TX860B
TX870B TX970B

801 802 803 804 805 806 807 808 813 814 815 816 817 821 822 823 824 825 831
833 841 843 845 851 853 855 921 922 923 931 932

68003C04.1

6199042M3

1

Jan-06

Loader Controls
Commandes de Chargeur
Mandos de cargadora

Hydraulic Valve
Distributeur de Commande Hydraulique
Distribuidor de mando hidráulico

Loader Arm Section
Élément Bras Chargeur
Elemento brazo cargador

7 in 1 Bucket
 7 in 1 Bucket
 7 in 1 Bucket

C-68003-05.1-A

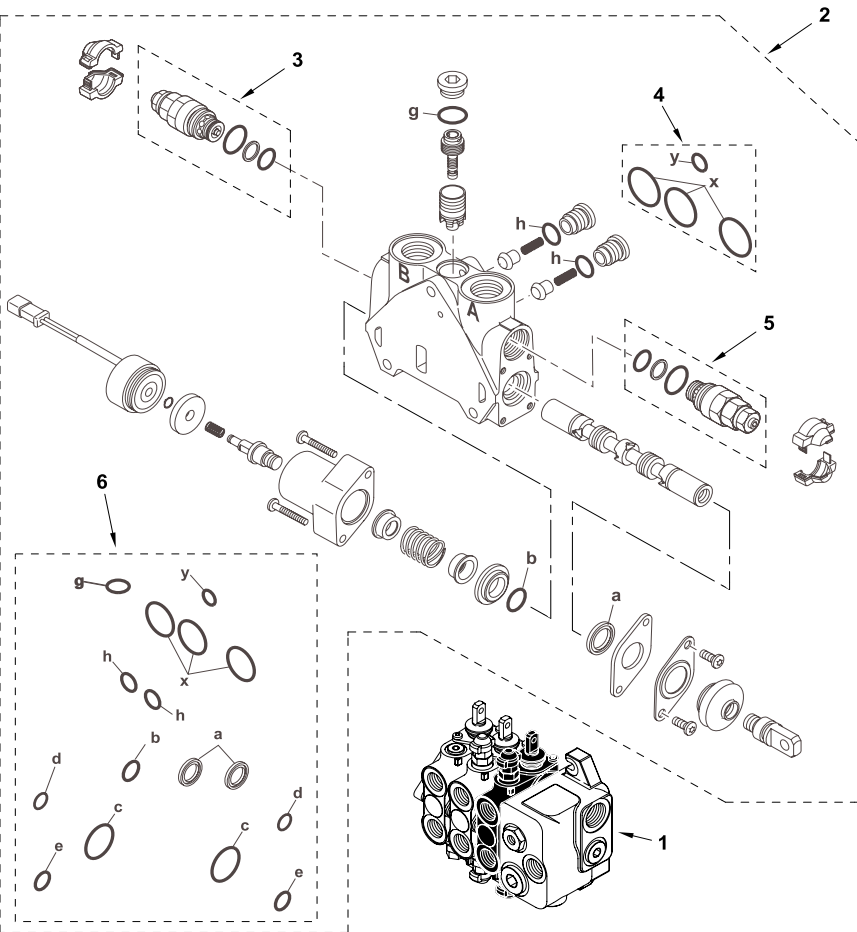

1	6109210M91	3 Spool	1	Valve Assy, Control	Ensemble distribution	Distribuidor, Conj.
2	6194531M91		1	Element - Bucket		
3	6193804M91		1	310 Bar PRV		
4	6193771M91	Interface	1	Kit, Seal	Pochette de joints	Juego de juntas
5	6193801M91		1	345 Bar PRV		
6	6193781M91		1	Kit, Seal	Pochette de joints	Juego de juntas



820 860 880 970 980
 TX760B TX860B
 TX870B TX970B

801 802 803 804 805 806 807 808 813 814 815 816 817 821 822 823 824 825 831
 833 841 843 845 851 853 855 921 922 923 931 932

68003C05.1

6199042M3

1

Jan-06

Loader Controls
Commandes de Chargeur
Mandos de cargadora

Hydraulic Valve
Distributeur de Commande Hydraulique
Distribuidor de mando hidráulico

Standard Bucket Section
Élément de Godet Standard
Elemento de cuchara estándar

7 in 1 Bucket
 7 in 1 Bucket
 7 in 1 Bucket

C-68003-06.1-A

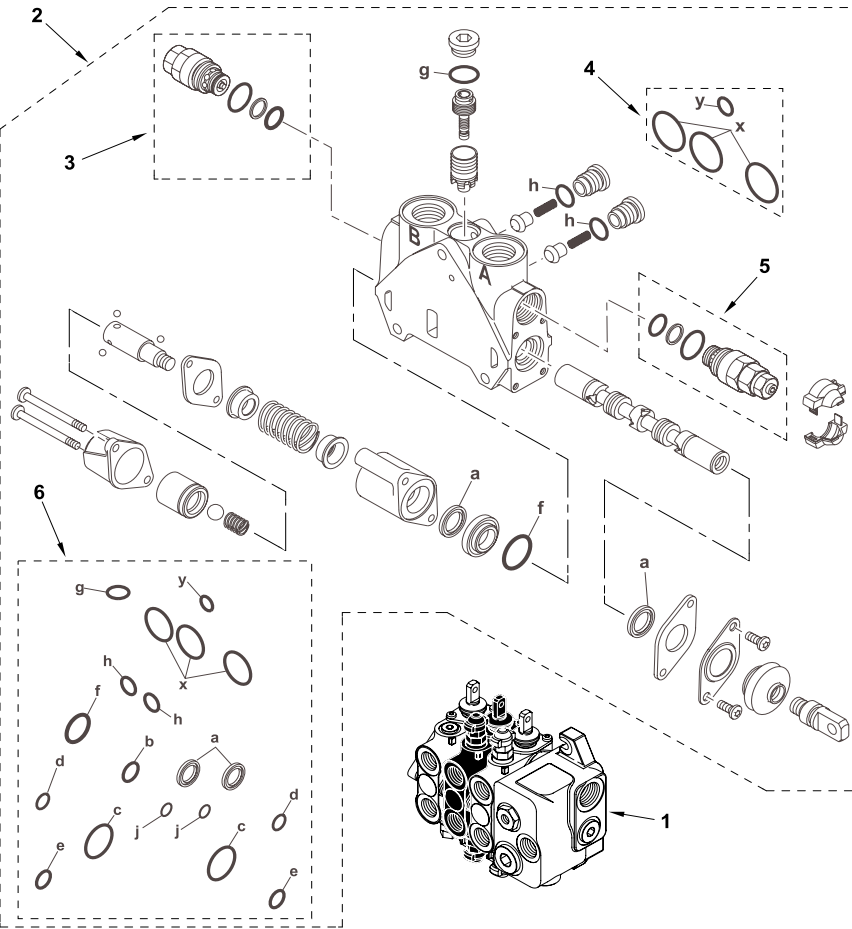

1	6109210M91	Continued 3 Spool	1	Valve Assy, Control	Ensemble distribution	Distribuidor, Conj.
2	6194532M91		1	Element - Dipper		
3	6193782M91	Anti-cavitation	1	Valve Assy	Ensemble de soupape	Válvula, Conj.
4	6193771M91	Interface	1	Kit, Seal	Pochette de joints	Juego de juntas
5	6193800M91		1	240 Bar PRV		
6	6194518M91		1	Kit, Seal	Pochette de joints	Juego de juntas



820 860 880 970 980
 TX760B TX860B
 TX870B TX970B

801 802 803 804 805 806 807 808 813 814 815 816 817 821 822 823 824 825 831
 833 841 843 845 851 853 855 921 922 923 931 932

68003C06.1

6199042M3

1

Jan-06

Loader Controls
Commandes de Chargeur
Mandos de cargadora

Hydraulic Valve
Distributeur de Commande Hydraulique
Distribuidor de mando hidráulico

Standard Bucket Section
Élément de Godet Standard
Elemento de cuchara estándar

7 in 1 Bucket
 7 in 1 Bucket
 7 in 1 Bucket

C-68003-07.1-A

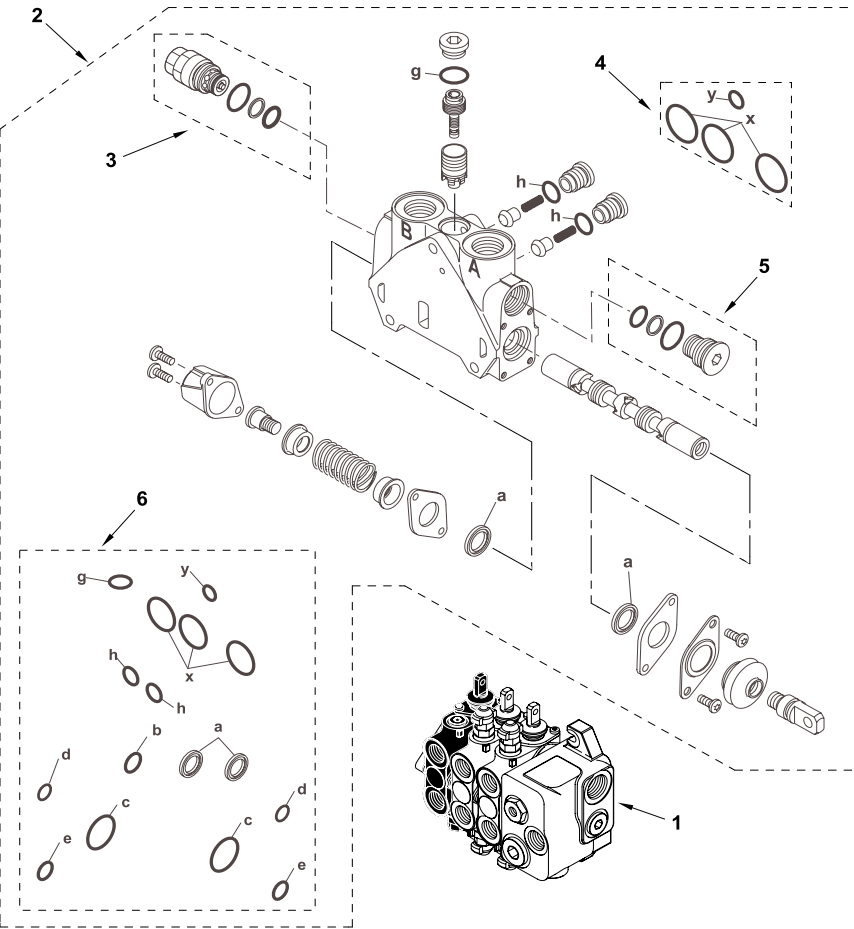

1	6109210M91	3 Spool	1	Valve Assy, Control	Ensemble distribution	Distribuidor, Conj.
2	6194533M91		1	Element 4x1		
3	6193782M91	Anti-cavitation	1	Valve Assy	Ensemble de soupape	Válvula, Conj.
4	6193771M91	Interface	1	Kit, Seal	Pochette de joints	Juego de juntas
5	6193785M91		1	Plug Assy	Ensemble bouchons	Tapón, Conj.
6	6193791M91	L/S Valve	1	Kit, Seal	Pochette de joints	Juego de juntas



820 860 880 970 980
 TX760B TX860B
 TX870B TX970B

801 802 803 804 805 806 807 808 813 814 815 816 817 821 822 823 824 825 831
 833 841 843 845 851 853 855 921 922 923 931 932

68003C07.1

6199042M3

1

Jan-06

Loader Controls
Commandes de Chargeur
Mandos de cargadora

Hydraulic Valve
Distributeur de Commande Hydraulique
Distribuidor de mando hidráulico

Standard Bucket Section
Élément de Godet Standard
Elemento de cuchara estándar

7 in 1 Bucket
 7 in 1 Bucket
 7 in 1 Bucket

C-68003-08.1-A

1	6109210M91	3 Spool	1	Valve Assy, Control	Ensemble distribution	Distribuidor, Conj.
2	6194517M91		1	Element - Outlet		
3	6193771M91	Interface	1	Kit, Seal	Pochette de joints	Juego de juntas

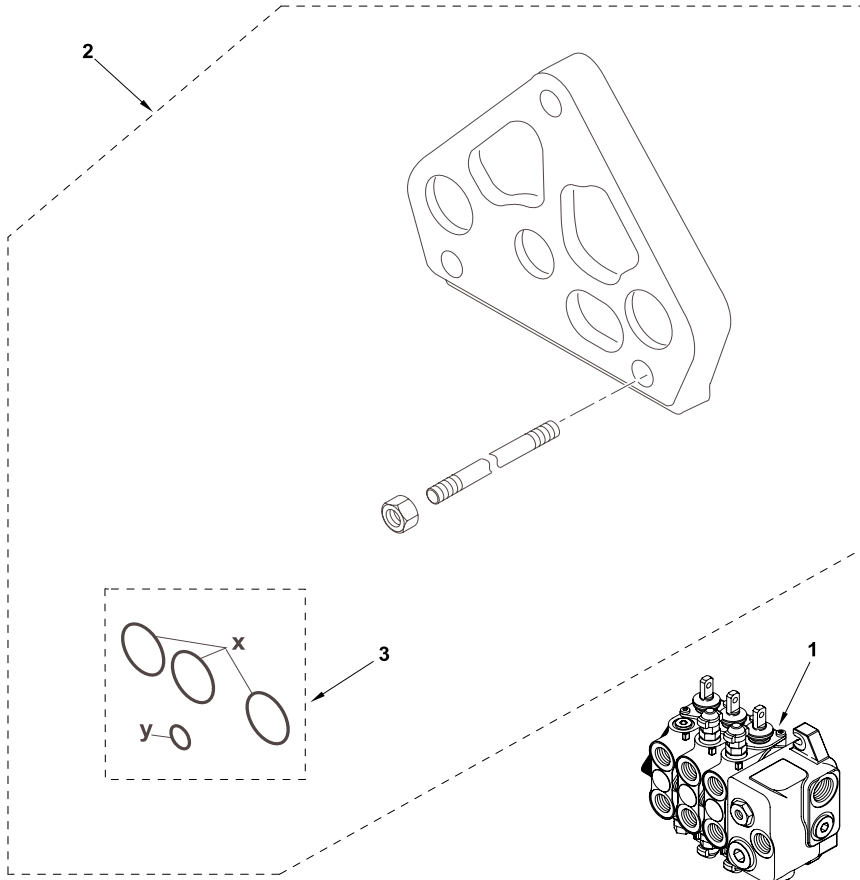

820 860 880 970 980
 TX760B TX860B
 TX870B TX970B

801 802 803 804 805 806 807 808 813 814 815 816 817 821 822 823 824 825 831
 833 841 843 845 851 853 855 921 922 923 931 932

68003C08.1

6199042M3

1

Jan-06

Loader Controls
Commandes de Chargeur
Mandos de cargadora

Hydraulic Valve
Distributeur de Commande Hydraulique
Distribuidor de mando hidráulico

Inlet
 Admission
 Admisión

7 in 1 Bucket
 7 in 1 Bucket
 7 in 1 Bucket

C-68004-04.1-A

1	6109210M91	3 Spool	1	Valve Assy, Control	Ensemble distribution	Distribuidor, Conj.
2	6194535M91	Inlet	1	Element - Inlet		
3	6193771M91	Interface	1	Kit, Seal	Pochette de joints	Juego de juntas

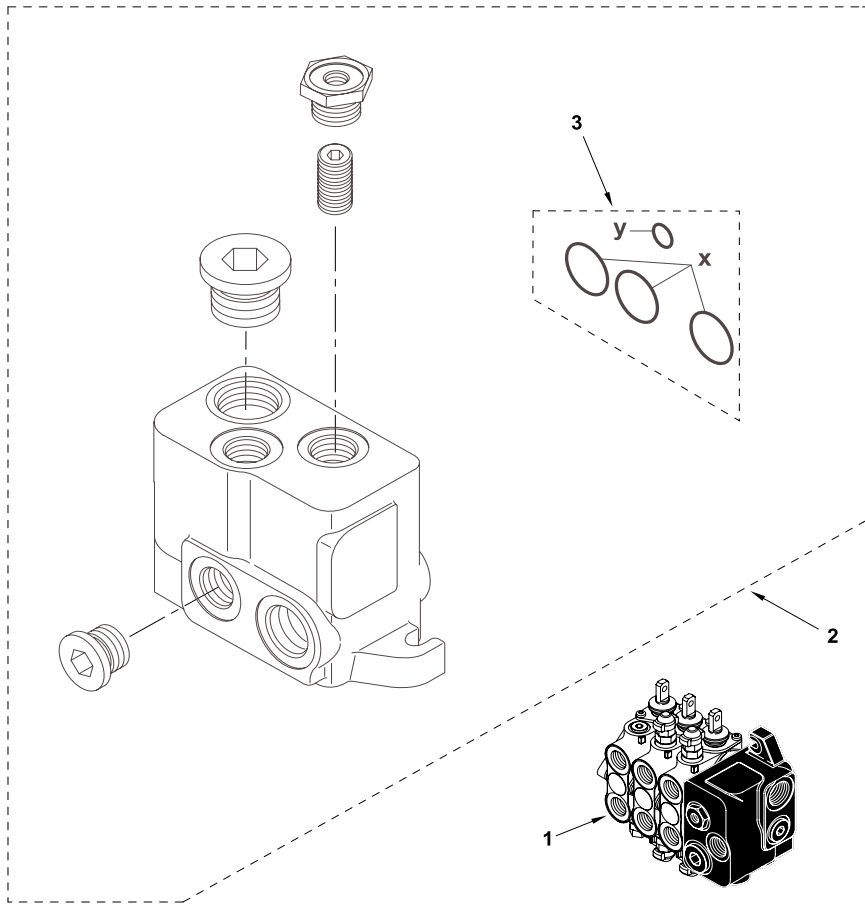

820 860 880 970 980
 TX760B TX860B
 TX870B TX970B

801 802 803 804 805 806 807 808 809 810 811 812 813 814 815 816 817 821 822
 823 824 825 831 833 841 843 845 851 853 854 855 921 922 923 931 932

68004C04.1

6199042M3

1

Jan-06

Loader Controls
 Commandes de Chargeur
 Mandos de cargadora

Hydraulic Valve
 Distributeur de Commande Hydraulique
 Distribuidor de mando hidráulico

Loader Arm Section
 Élément Bras Chargeur
 Elemento brazo cargador

7 in 1 Bucket
 7 in 1 Bucket
 7 in 1 Bucket

C-68004-05.1-A

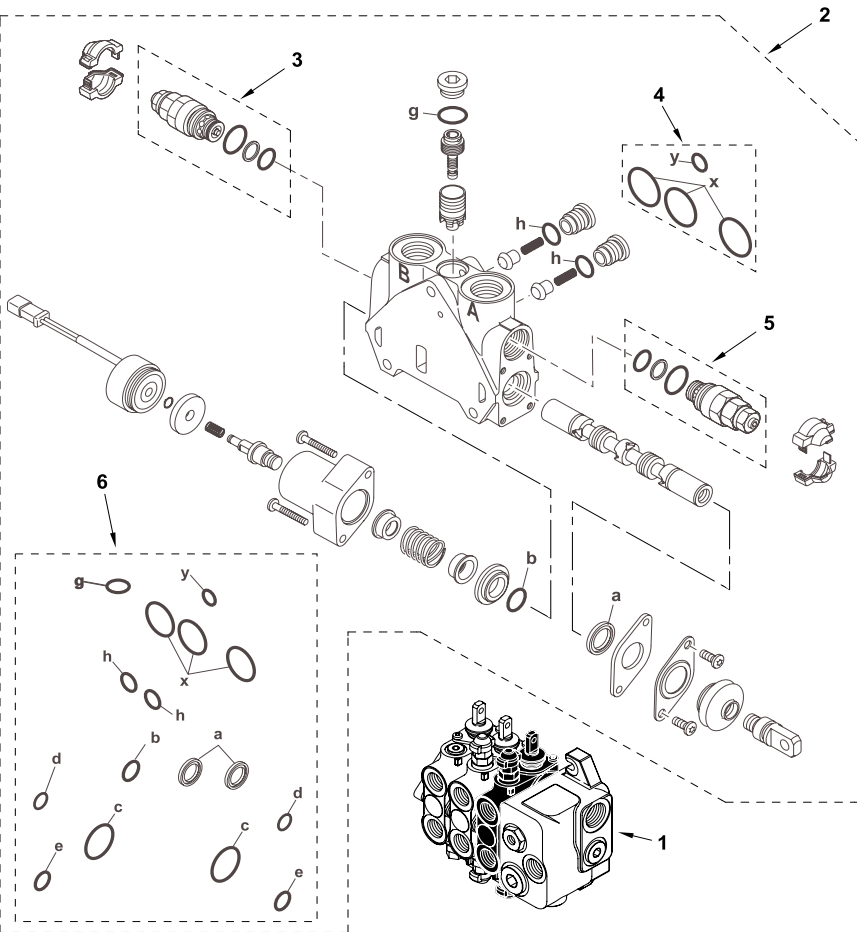

1	6109210M91	3 Spool	1	Valve Assy, Control	Ensemble distribution	Distribuidor, Conj.
2	6194531M91		1	Element - Bucket		
3	6193804M91		1	310 Bar PRV		
4	6193771M91	Interface	1	Kit, Seal	Pochette de joints	Juego de juntas
5	6193801M91		1	345 Bar PRV		
6	6193781M91		1	Kit, Seal	Pochette de joints	Juego de juntas



820 860 880 970 980
 TX760B TX860B
 TX870B TX970B

801 802 803 804 805 806 807 808 809 810 811 812 813 814 815 816 817 821 822
 823 824 825 831 833 841 843 845 851 853 854 855 921 922 923 931 932

68004C05.1

6199042M3

1

Jan-06

Loader Controls
Commandes de Chargeur
Mandos de cargadora

Hydraulic Valve
Distributeur de Commande Hydraulique
Distribuidor de mando hidráulico

Standard Bucket Section
Élément de Godet Standard
Elemento de cuchara estándar

7 in 1 Bucket
 7 in 1 Bucket
 7 in 1 Bucket

C-68004-06.1-A

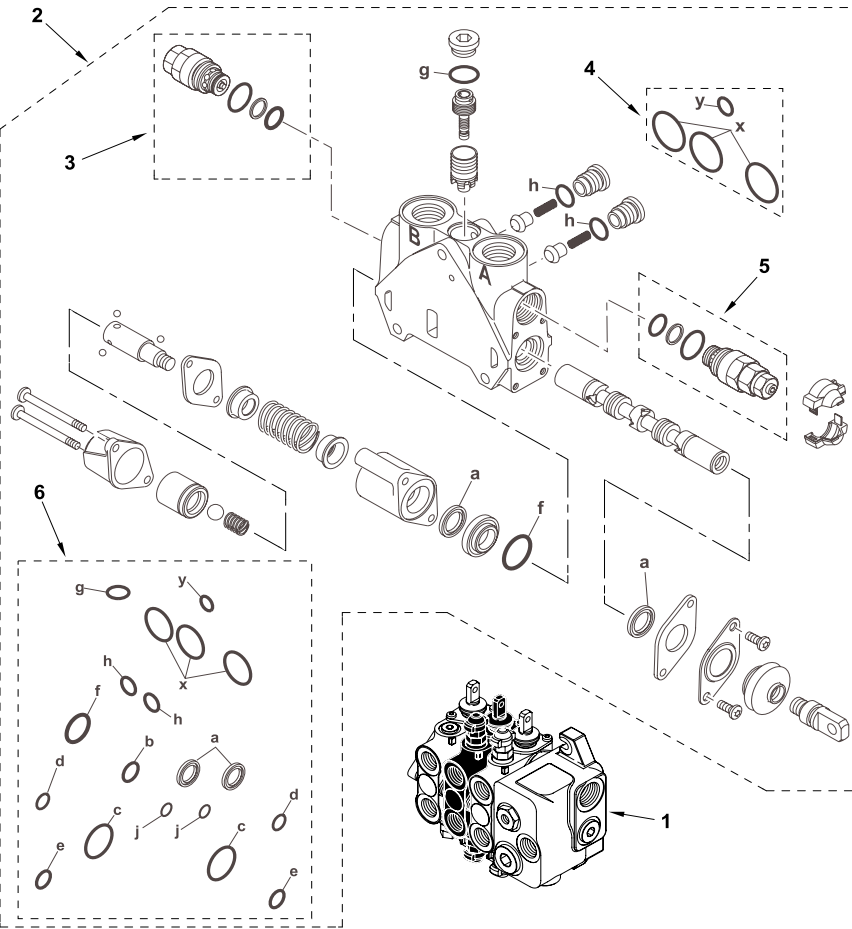

1	6109210M91		Continued 3 Spool	1	Valve Assy, Control	Ensemble distribution	Distribuidor, Conj.
2	6194532M91			1	Element - Dipper		
3	6193782M91		Anti-cavitation	1	Valve Assy	Ensemble de soupape	Válvula, Conj.
4	6193771M91		Interface	1	Kit, Seal	Pochette de joints	Juego de juntas
5	6193800M91			1	240 Bar PRV		
6	6194518M91			1	Kit, Seal	Pochette de joints	Juego de juntas



820 860 880 970 980
 TX760B TX860B
 TX870B TX970B

801 802 803 804 805 806 807 808 809 810 811 812 813 814 815 816 817 821 822
 823 824 825 831 833 841 843 845 851 853 854 855 921 922 923 931 932

68004C06.1

6199042M3

1

Jan-06

Loader Controls
Commandes de Chargeur
Mandos de cargadora

Hydraulic Valve
Distributeur de Commande Hydraulique
Distribuidor de mando hidráulico

Standard Bucket Section
Élément de Godet Standard
Elemento de cuchara estándar

7 in 1 Bucket
 7 in 1 Bucket
 7 in 1 Bucket

C-68004-07.1-A

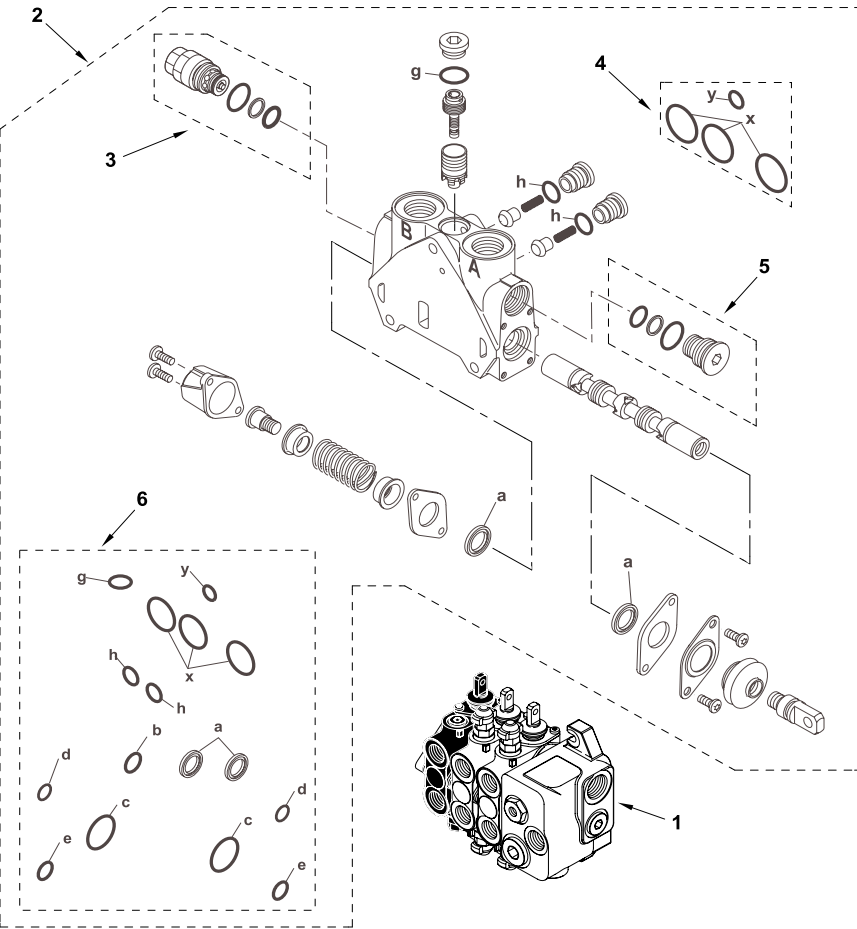

1	6109210M91	3 Spool	1	Valve Assy, Control	Ensemble distribution	Distribuidor, Conj.
2	6194533M91		1	Element 4x1		
3	6193782M91	Anti-cavitation	1	Valve Assy	Ensemble de soupape	Válvula, Conj.
4	6193771M91	Interface	1	Kit, Seal	Pochette de joints	Juego de juntas
5	6193785M91		1	Plug Assy	Ensemble bouchons	Tapón, Conj.
6	6193791M91	L/S Valve	1	Kit, Seal	Pochette de joints	Juego de juntas



820 860 880 970 980
 TX760B TX860B
 TX870B TX970B

801 802 803 804 805 806 807 808 809 810 811 812 813 814 815 816 817 821 822
 823 824 825 831 833 841 843 845 851 853 854 855 921 922 923 931 932

68004C07.1

6199042M3

1

Jan-06

Loader Controls
Commandes de Chargeur
Mandos de cargadora

Hydraulic Valve
Distributeur de Commande Hydraulique
Distribuidor de mando hidráulico

Standard Bucket Section
Élément de Godet Standard
Elemento de cuchara estándar

7 in 1 Bucket
 7 in 1 Bucket
 7 in 1 Bucket

C-68004-08.1-A

1	6109210M91	3 Spool	1	Valve Assy, Control	Ensemble distribution	Distribuidor, Conj.
2	6194517M91		1	Element - Outlet		
3	6193771M91	Interface	1	Kit, Seal	Pochette de joints	Juego de juntas

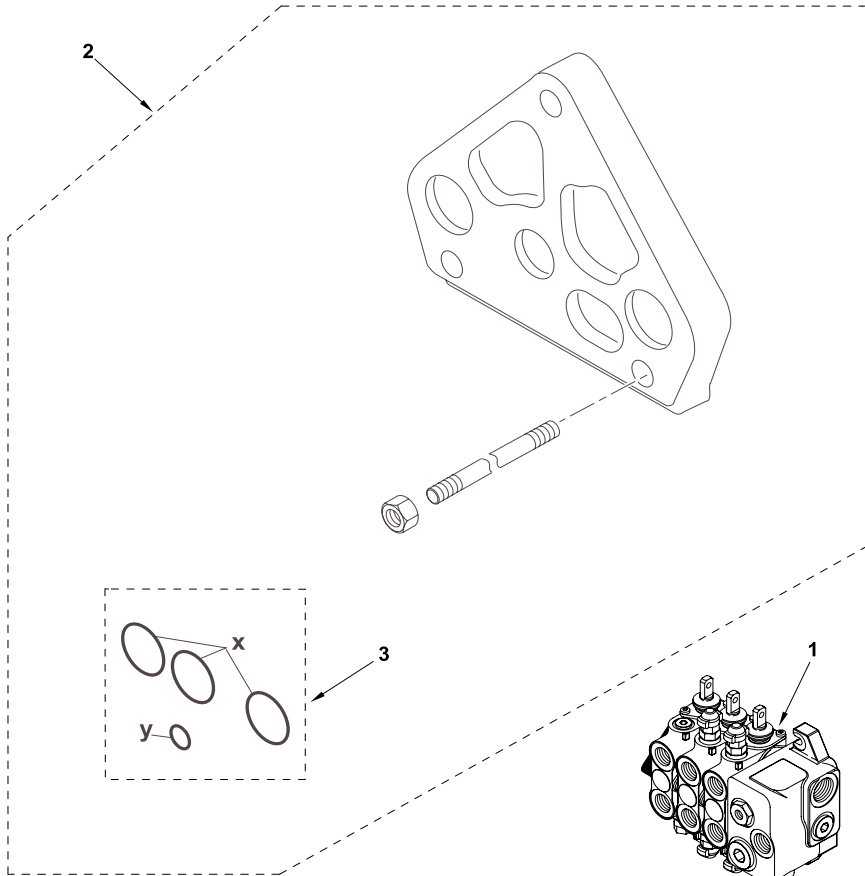

820 860 880 970 980
 TX760B TX860B
 TX870B TX970B

801 802 803 804 805 806 807 808 809 810 811 812 813 814 815 816 817 821 822
 823 824 825 831 833 841 843 845 851 853 854 855 921 922 923 931 932

68004C08.1

6199042M3

1

Jan-06

Loader Controls
 Commandes de Chargeur
 Mandos de cargadora

Hydraulic Valve
 Distributeur de Commande Hydraulique
 Distribuidor de mando hidráulico

Inlet
 Admission
 Admisión

7 in 1 Bucket
 7 in 1 Bucket
 7 in 1 Bucket

C-68006-04.1-A

1	6109210M91	3 Spool	1	Valve Assy, Control	Ensemble distribution	Distribuidor, Conj.
2	6194535M91	Inlet	1	Element - Inlet		
3	6193771M91	Interface	1	Kit, Seal	Pochette de joints	Juego de juntas

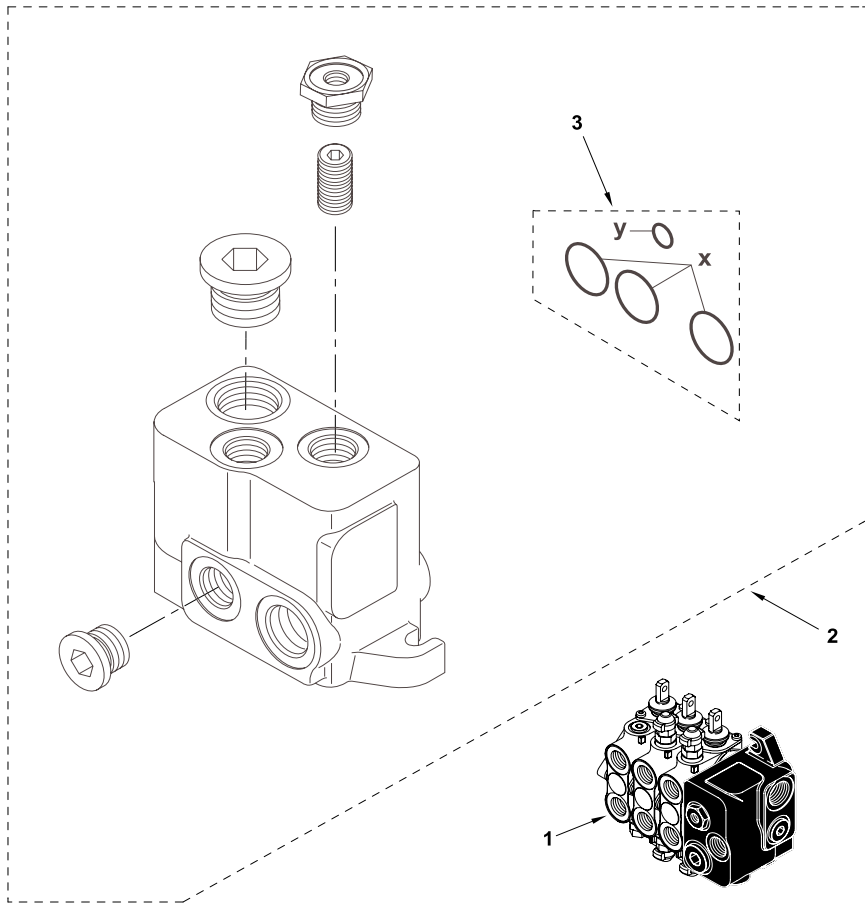

820 860 880 970 980
 TX760B TX860B
 TX870B TX970B

801 802 803 804 805 806 807 808 813 814 815 816 817 821 822 823 824 825 831
 833 841 843 845 851 853 855 921 922 923 931 932

68006C04.1

6199042M3

1

Jan-06

Loader Controls
 Commandes de Chargeur
 Mandos de cargadora

Hydraulic Valve
 Distributeur de Commande Hydraulique
 Distribuidor de mando hidráulico

Loader Arm Section
 Élément Bras Chargeur
 Elemento brazo cargador

7 in 1 Bucket
 7 in 1 Bucket
 7 in 1 Bucket

C-68006-05.1-A

1	6109210M91	3 Spool	1	Valve Assy, Control	Ensemble distribution	Distribuidor, Conj.
2	6194531M91		1	Element - Bucket		
3	6193804M91		1	310 Bar PRV		
4	6193771M91	Interface	1	Kit, Seal	Pochette de joints	Juego de juntas
5	6193801M91		1	345 Bar PRV		
6	6193781M91		1	Kit, Seal	Pochette de joints	Juego de juntas

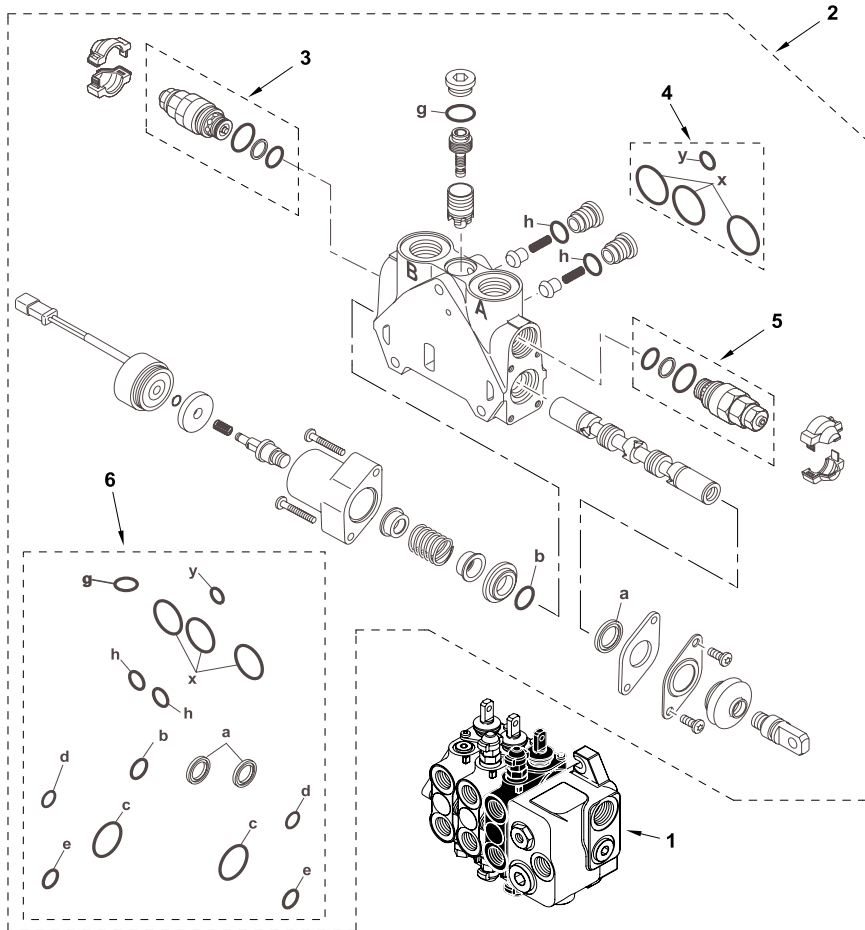

820 860 880 970 980
 TX760B TX860B
 TX870B TX970B

801 802 803 804 805 806 807 808 813 814 815 816 817 821 822 823 824 825 831
 833 841 843 845 851 853 855 921 922 923 931 932

68006C05.1

6199042M3

1

Jan-06

Loader Controls
Commandes de Chargeur
Mandos de cargadora

Hydraulic Valve
Distributeur de Commande Hydraulique
Distribuidor de mando hidráulico

Standard Bucket Section
Élément de Godet Standard
Elemento de cuchara estándar

7 in 1 Bucket
 7 in 1 Bucket
 7 in 1 Bucket

C-68006-06.1-A

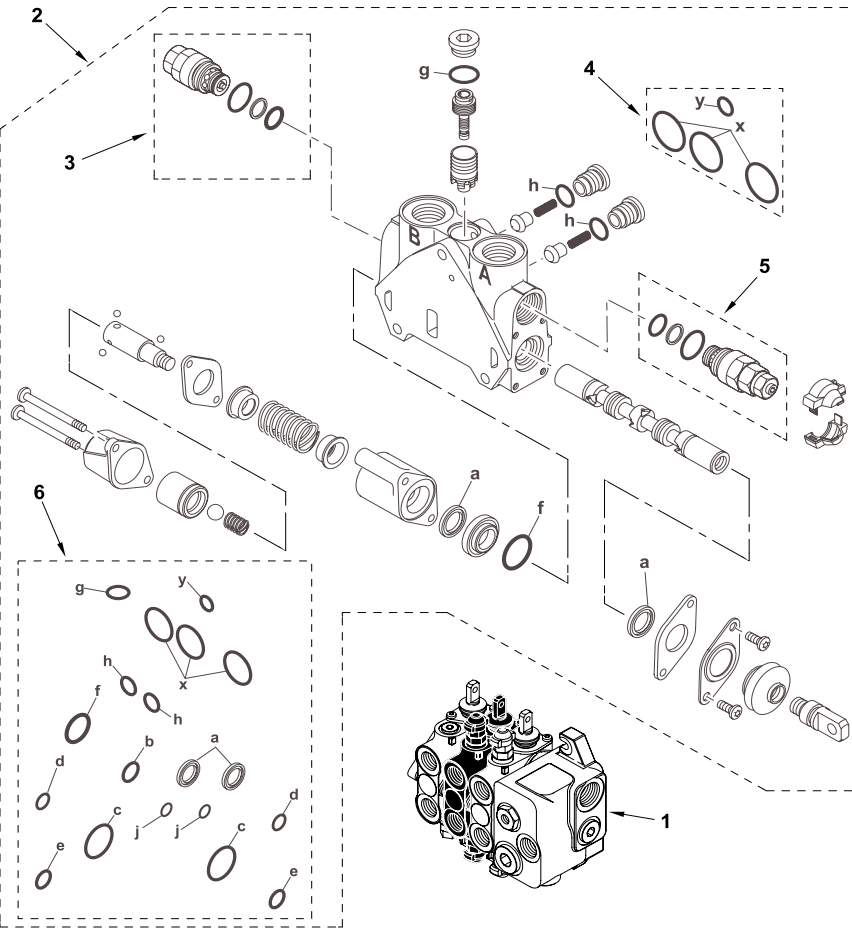

1	6109210M91	Continued 3 Spool	1	Valve Assy, Control	Ensemble distribution	Distribuidor, Conj.
2	6194532M91		1	Element - Dipper		
3	6193782M91	Anti-cavitation	1	Valve Assy	Ensemble de soupape	Válvula, Conj.
4	6193771M91	Interface	1	Kit, Seal	Pochette de joints	Juego de juntas
5	6193800M91		1	240 Bar PRV		
6	6194518M91		1	Kit, Seal	Pochette de joints	Juego de juntas



820 860 880 970 980
 TX760B TX860B
 TX870B TX970B

801 802 803 804 805 806 807 808 813 814 815 816 817 821 822 823 824 825 831
 833 841 843 845 851 853 855 921 922 923 931 932

68006C06.1

6199042M3

1

Jan-06

Loader Controls
Commandes de Chargeur
Mandos de cargadora

Hydraulic Valve
Distributeur de Commande Hydraulique
Distribuidor de mando hidráulico

Standard Bucket Section
Élément de Godet Standard
Elemento de cuchara estándar

7 in 1 Bucket
 7 in 1 Bucket
 7 in 1 Bucket

C-68006-07.1-A

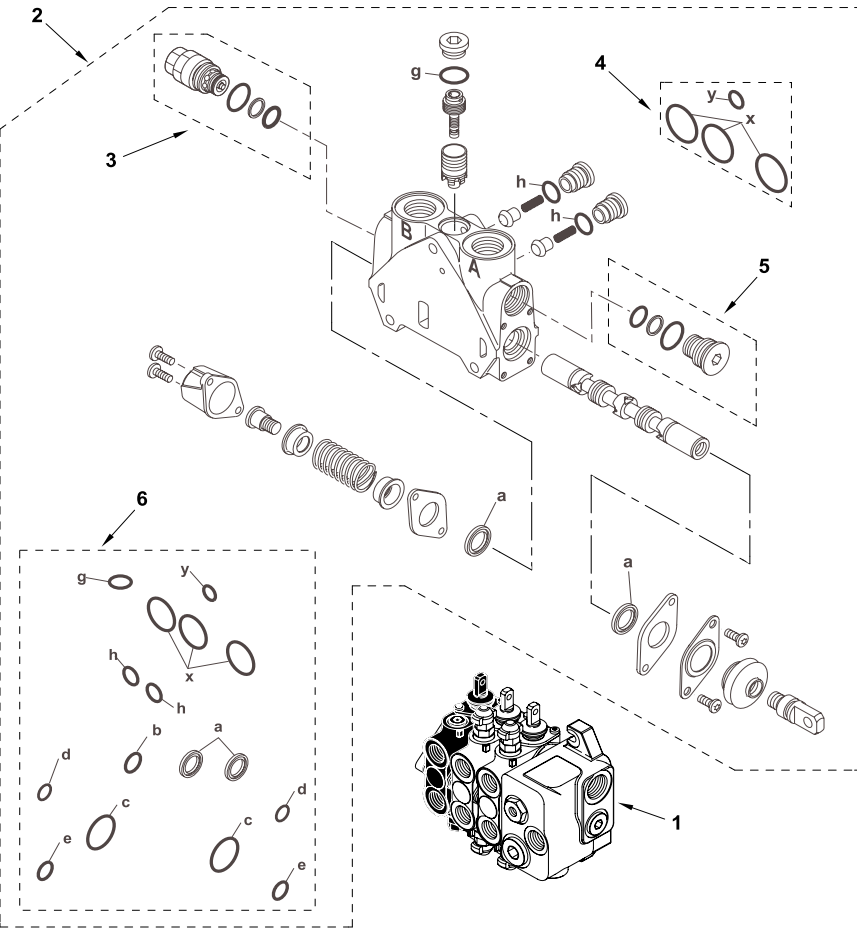

1	6109210M91	3 Spool	1	Valve Assy, Control	Ensemble distribution	Distribuidor, Conj.
2	6194533M91		1	Element 4x1		
3	6193782M91	Anti-cavitation	1	Valve Assy	Ensemble de soupape	Válvula, Conj.
4	6193771M91	Interface	1	Kit, Seal	Pochette de joints	Juego de juntas
5	6193785M91		1	Plug Assy	Ensemble bouchons	Tapón, Conj.
6	6193791M91	L/S Valve	1	Kit, Seal	Pochette de joints	Juego de juntas



820 860 880 970 980
 TX760B TX860B
 TX870B TX970B

801 802 803 804 805 806 807 808 813 814 815 816 817 821 822 823 824 825 831
 833 841 843 845 851 853 855 921 922 923 931 932

68006C07.1

6199042M3

1

Jan-06

Loader Controls
Commandes de Chargeur
Mandos de cargadora

Hydraulic Valve
Distributeur de Commande Hydraulique
Distribuidor de mando hidráulico

Standard Bucket Section
Élément de Godet Standard
Elemento de cuchara estándar

7 in 1 Bucket
 7 in 1 Bucket
 7 in 1 Bucket

C-68006-08.1-A

1	6109210M91	3 Spool	1	Valve Assy, Control	Ensemble distribution	Distribuidor, Conj.
2	6194517M91		1	Element - Outlet		
3	6193771M91	Interface	1	Kit, Seal	Pochette de joints	Juego de juntas

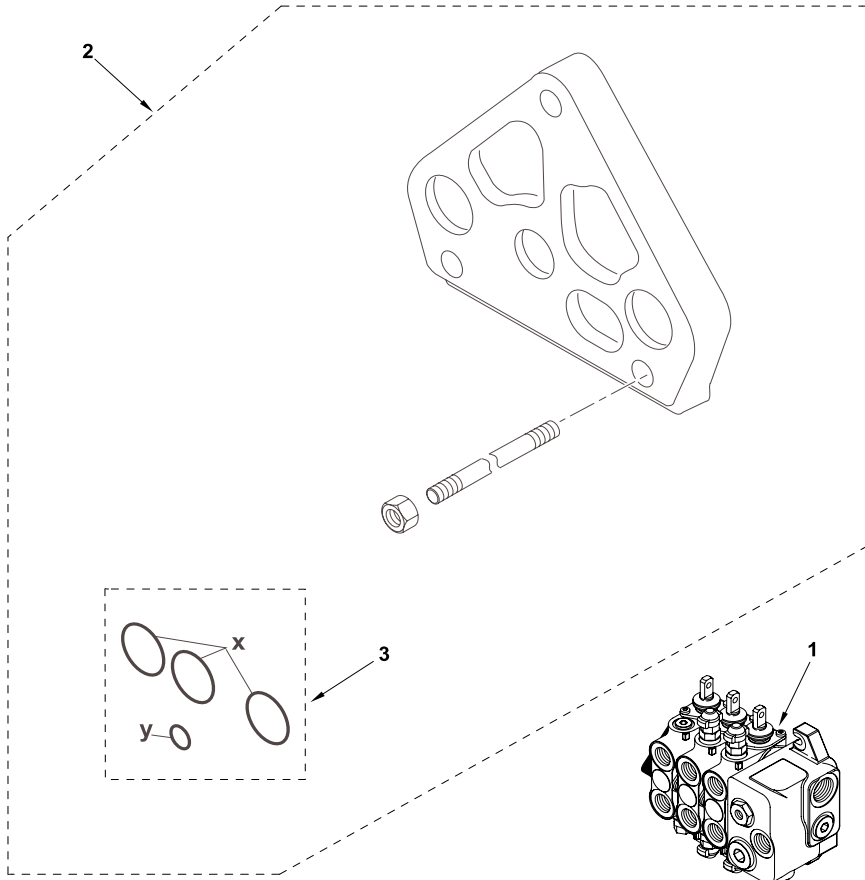

820 860 880 970 980
 TX760B TX860B
 TX870B TX970B

801 802 803 804 805 806 807 808 813 814 815 816 817 821 822 823 824 825 831
 833 841 843 845 851 853 855 921 922 923 931 932

68006C08.1

6199042M3

1

Jan-06

Loader Controls
Commandes de Chargeur
Mandos de cargadora

Hydraulic Valve
Distributeur de Commande Hydraulique
Distribuidor de mando hidráulico

Inlet
 Admission
 Admisión

7 in 1 Bucket
 7 in 1 Bucket
 7 in 1 Bucket

C-68007-04.1-A

1	6109210M91	3 Spool	1	Valve Assy, Control	Ensemble distribution	Distribuidor, Conj.
2	6194535M91	Inlet	1	Element - Inlet		
3	6193771M91	Interface	1	Kit, Seal	Pochette de joints	Juego de juntas

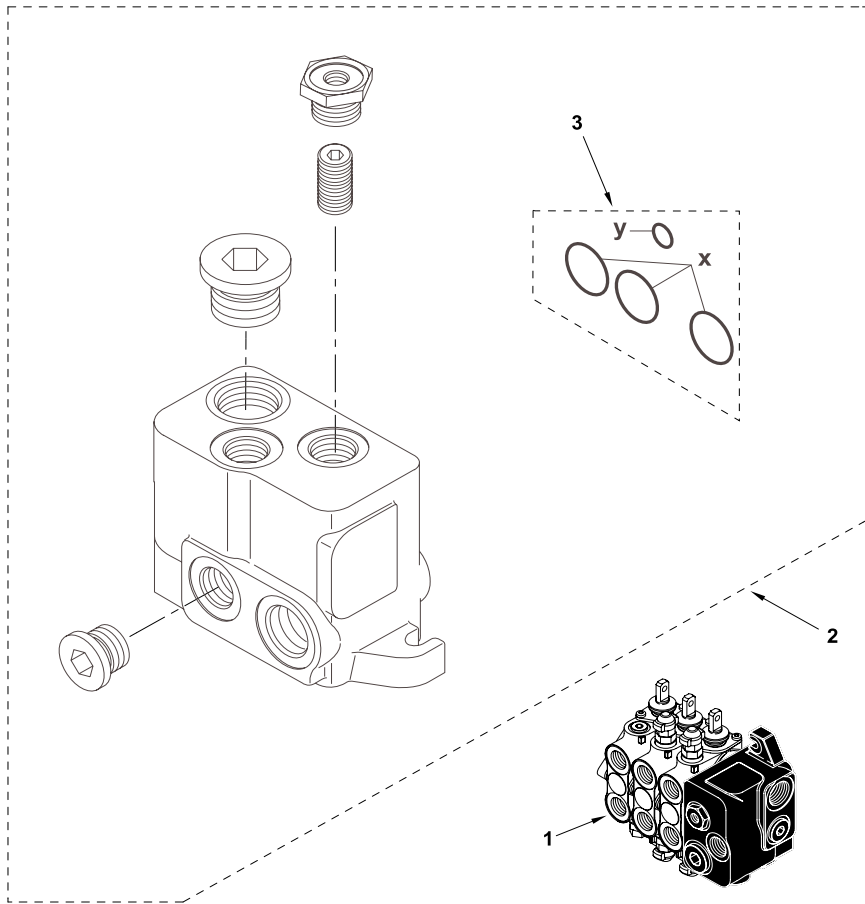

820 860 880 970 980
 TX760B TX860B
 TX870B TX970B

801 802 803 804 805 806 807 808 809 810 811 812 813 814 815 816 817 821 822
 823 824 825 831 833 841 843 845 851 853 855 921 922 923 931 932

68007C04.1

6199042M3

1

Jan-06

Loader Controls
 Commandes de Chargeur
 Mandos de cargadora

Hydraulic Valve
 Distributeur de Commande Hydraulique
 Distribuidor de mando hidráulico

Loader Arm Section
 Élément Bras Chargeur
 Elemento brazo cargador

7 in 1 Bucket
 7 in 1 Bucket
 7 in 1 Bucket

C-68007-05.1-A

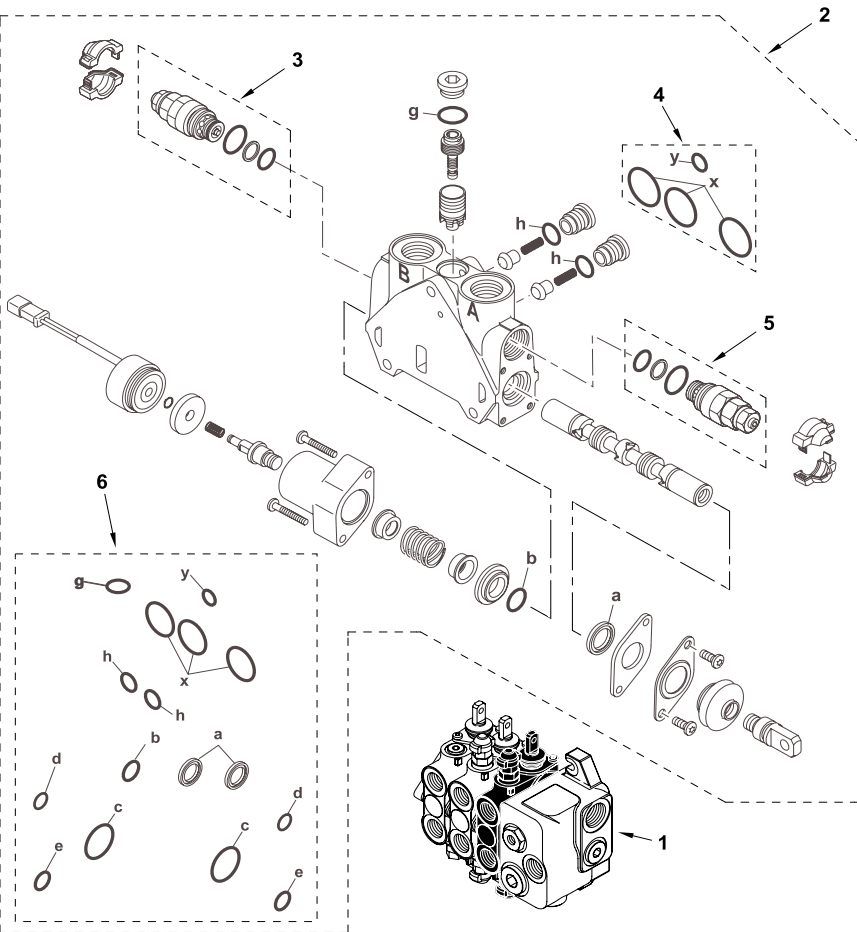

1	6109210M91	3 Spool	1	Valve Assy, Control	Ensemble distribution	Distribuidor, Conj.
2	6194531M91		1	Element - Bucket		
3	6193804M91		1	310 Bar PRV		
4	6193771M91	Interface	1	Kit, Seal	Pochette de joints	Juego de juntas
5	6193801M91		1	345 Bar PRV		
6	6193781M91		1	Kit, Seal	Pochette de joints	Juego de juntas



820 860 880 970 980
 TX760B TX860B
 TX870B TX970B

801 802 803 804 805 806 807 808 809 810 811 812 813 814 815 816 817 821 822
 823 824 825 831 833 841 843 845 851 853 855 921 922 923 931 932

68007C05.1

6199042M3

1

Jan-06

Loader Controls
Commandes de Chargeur
Mandos de cargadora

Hydraulic Valve
Distributeur de Commande Hydraulique
Distribuidor de mando hidráulico

Standard Bucket Section
Élément de Godet Standard
Elemento de cuchara estándar

7 in 1 Bucket
 7 in 1 Bucket
 7 in 1 Bucket

C-68007-06.1-A

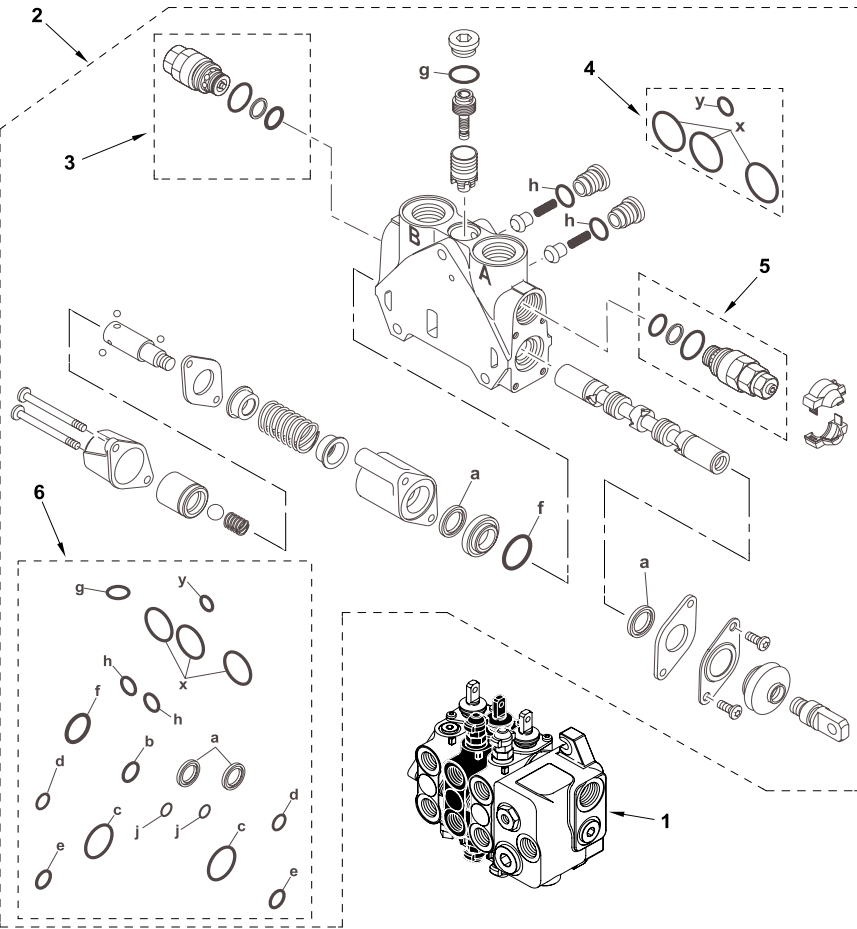

1	6109210M91	Continued 3 Spool	1	Valve Assy, Control	Ensemble distribution	Distribuidor, Conj.
2	6194532M91		1	Element - Dipper		
3	6193782M91	Anti-cavitation	1	Valve Assy	Ensemble de soupape	Válvula, Conj.
4	6193771M91	Interface	1	Kit, Seal	Pochette de joints	Juego de juntas
5	6193800M91		1	240 Bar PRV		
6	6194518M91		1	Kit, Seal	Pochette de joints	Juego de juntas



820 860 880 970 980
 TX760B TX860B
 TX870B TX970B

801 802 803 804 805 806 807 808 809 810 811 812 813 814 815 816 817 821 822
 823 824 825 831 833 841 843 845 851 853 855 921 922 923 931 932

68007C06.1

6199042M3

1

Jan-06

Loader Controls
Commandes de Chargeur
Mandos de cargadora

Hydraulic Valve
Distributeur de Commande Hydraulique
Distribuidor de mando hidráulico

Standard Bucket Section
Élément de Godet Standard
Elemento de cuchara estándar

7 in 1 Bucket
 7 in 1 Bucket
 7 in 1 Bucket

C-68007-07.1-A

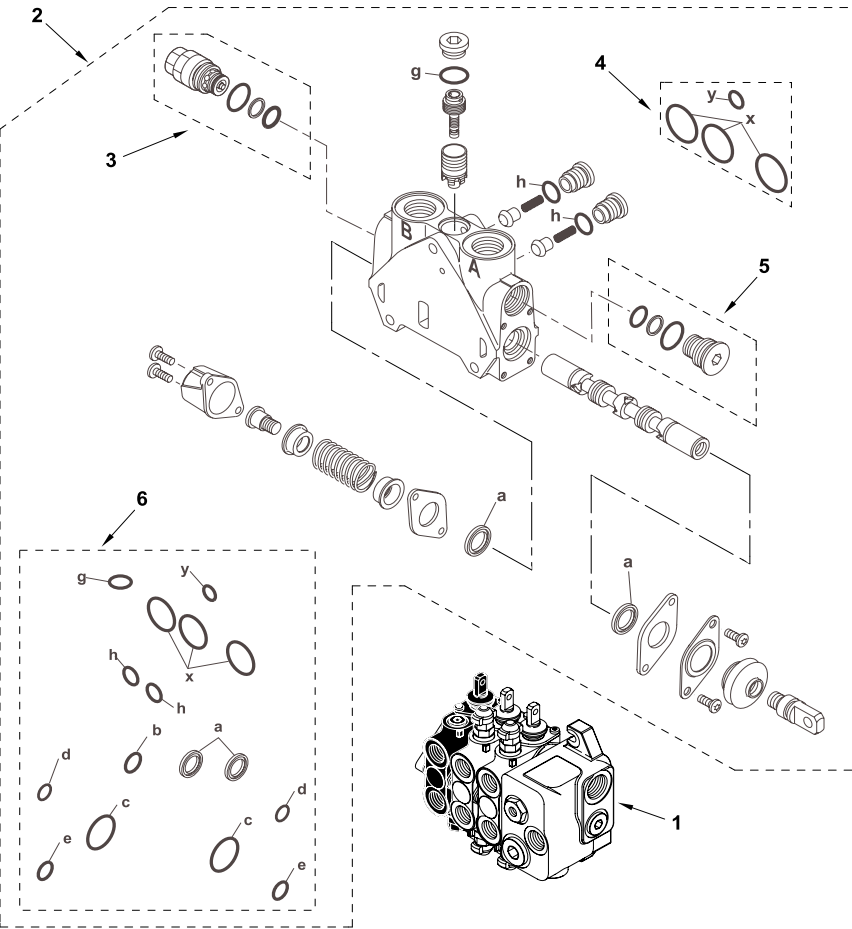

1	6109210M91	3 Spool	1	Valve Assy, Control	Ensemble distribution	Distribuidor, Conj.
2	6194533M91		1	Element 4x1		
3	6193782M91	Anti-cavitation	1	Valve Assy	Ensemble de soupape	Válvula, Conj.
4	6193771M91	Interface	1	Kit, Seal	Pochette de joints	Juego de juntas
5	6193785M91		1	Plug Assy	Ensemble bouchons	Tapón, Conj.
6	6193791M91	L/S Valve	1	Kit, Seal	Pochette de joints	Juego de juntas



820 860 880 970 980
 TX760B TX860B
 TX870B TX970B

801 802 803 804 805 806 807 808 809 810 811 812 813 814 815 816 817 821 822
 823 824 825 831 833 841 843 845 851 853 855 921 922 923 931 932

68007C07.1

6199042M3

1

Jan-06

Loader Controls
Commandes de Chargeur
Mandos de cargadora

Hydraulic Valve
Distributeur de Commande Hydraulique
Distribuidor de mando hidráulico

Standard Bucket Section
Élément de Godet Standard
Elemento de cuchara estándar

7 in 1 Bucket
 7 in 1 Bucket
 7 in 1 Bucket

C-68007-08.1-A

1	6109210M91	3 Spool	1	Valve Assy, Control	Ensemble distribution	Distribuidor, Conj.
2	6194517M91		1	Element - Outlet		
3	6193771M91	Interface	1	Kit, Seal	Pochette de joints	Juego de juntas

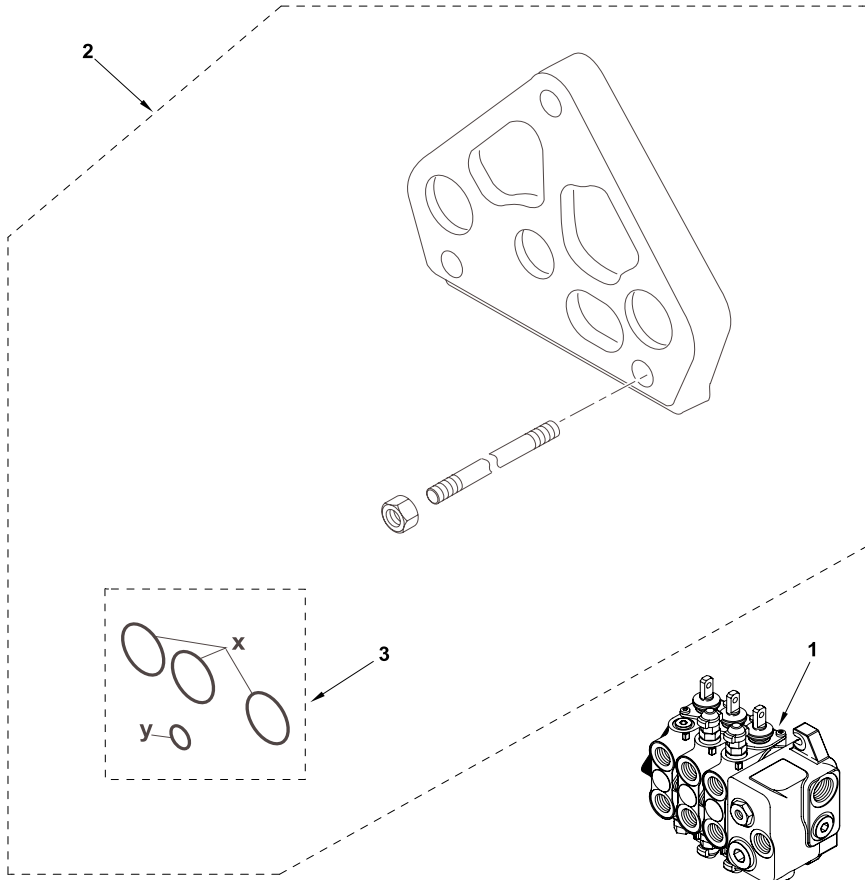

820 860 880 970 980
 TX760B TX860B
 TX870B TX970B

801 802 803 804 805 806 807 808 809 810 811 812 813 814 815 816 817 821 822
 823 824 825 831 833 841 843 845 851 853 855 921 922 923 931 932

68007C08.1

6199042M3

1

Jan-06

Loader Controls
Commandes de Chargeur
Mandos de cargadora



Hydraulic Valve
Distributeur de Commande Hydraulique
Distribuidor de mando hidráulico

Inlet
Admission
Admision

7 in 1 Bucket
 7 in 1 Bucket
 7 in 1 Bucket

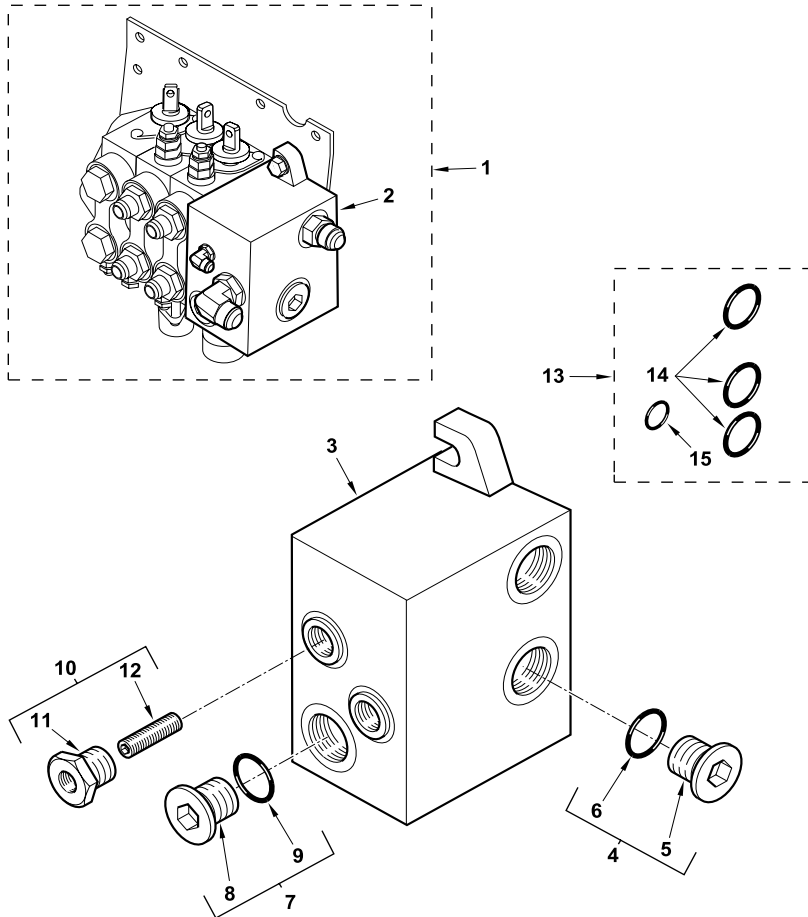
C-68008-04.1-A



1	6109210M91	3 Spool	1	Valve Assy, Control	Ensemble distribution	Distribuidor, Conj.
2		1 (A)Inlet	1	Valve	Soupape	Válvula
3		2	1	Body	Corps	Cuerpo
4	6193773M91	2 1 1/16" UNF	1	Plug Assy	Ensemble bouchons	Tapón, Conj.
5		4  Ref. 4	1	Plug	Bouchon	Tapón
6		4  Ref. 4	1	O-Ring	Joint torique	Junta de tipo O
7	6193772M91	2 5/16" UNF	1	Plug Assy	Ensemble bouchons	Tapón, Conj.
8		7  Ref. 7	1	Plug	Bouchon	Tapón
9		7  Ref. 7	1	O-Ring	Joint torique	Junta de tipo O
10	6193770M91	2	1	Valve Assy	Ensemble de soupape	Válvula, Conj.
11		10  Ref. 10	1	Valve	Soupape	Válvula
12		10  Ref. 10	1	Spring	Ressort	Muelle
13	6193771M91	Interface	X	Kit, Seal	Pochette de joints	Juego de juntas
14		13  Ref. 13	3	O-Ring	Joint torique	Junta de tipo O
15		13  Ref. 13	1	O-Ring	Joint torique	Junta de tipo O

A Part number to be advised
 Référence pièce à demander
 Indicar número de pieza



880
 TX760B TX860B
 TX870B

832 834 842 844 852 854

68008C04.1

6199042M3

1

Jan-06

Loader Controls
Commandes de Chargeur
Mandos de cargadora

Hydraulic Valve
Distributeur de Commande Hydraulique
Distribuidor de mando hidráulico

Loader Arm Section
Élément Bras Chargeur
Elemento brazo cargador

7 in 1 Bucket
 7 in 1 Bucket
 7 in 1 Bucket

C-68008-05.1-A

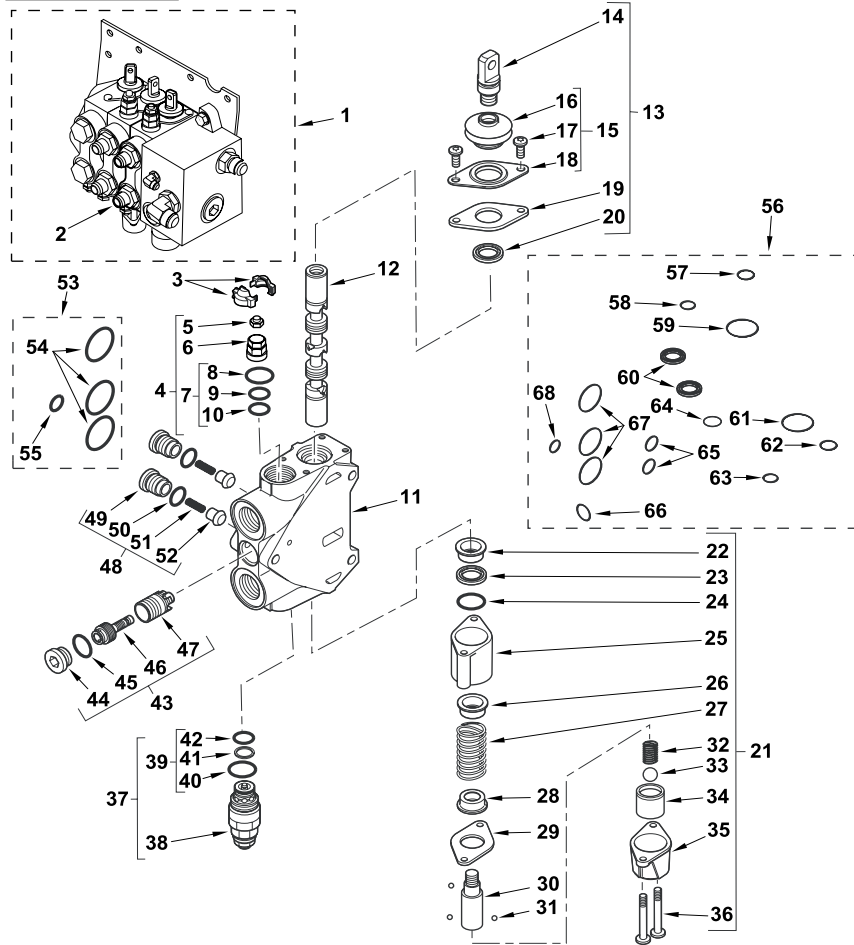

1	6109210M91		Continued 3 Spool	1	Valve Assy, Control	Ensemble distribution	Distribuidor, Conj.
2		1	(A)	1	Valve	Soupape	Válvula
3		2	Ref. 2	X	Cover	Cache	Tapa
4	6193778M91	2		1	Valve, Press. Relief	Soupape de sécurité	Válvula de seguridad
5		4	Ref. 4	1	Nut	Écrou	Tuerca
6		4	Ref. 4	1	Valve	Soupape	Válvula
7	6193779M91	4	Secondary Valves	1	Kit, Seal	Pochette de joints	Juego de juntas
8		7	Ref. 7	1	O-Ring	Joint torique	Junta de tipo O
9		7	Ref. 7	1	O-Ring	Joint torique	Junta de tipo O
10		7	Ref. 7	1	O-Ring	Joint torique	Junta de tipo O
11		2	Ref. 2	1	Body	Corps	Cuerpo
12		2	Ref. 2	1	Spool	Tiroir	Cajoncillo
13	6193780M91	2	Mech. Optd Z1	1	Kit, Parts	Lot de pièces	Juego de piezas
14		13	Ref. 13	1	Screw	Vis	Tornillo
15	6193783M91	13	Ref. 13 Bellows	1	Kit, Parts	Lot de pièces	Juego de piezas
16		15	Ref. 15	1	Seal	Joint	Junta
17		15	Ref. 15	2	Screw	Vis	Tornillo
18		15	Ref. 15	1	Cover	Cache	Tapa
19		13	Ref. 13	1	Plate	Plaque	Placa
20	6194492M1	13	Lip	1	Seal	Joint	Junta
21	6193797M91	2	Mech. Optd E2	1	Kit, Parts	Lot de pièces	Juego de piezas
22		21	Ref. 21	1	Guide	Guide	Guía
23	6194492M1	21	Lip	1	Seal	Joint	Junta
24		21	Ref. 21	1	O-Ring	Joint torique	Junta de tipo O
25		21	Ref. 21	1	Body	Corps	Cuerpo
26		21	Ref. 21	1	Holder	Porte-injecteur	Retén
27		21	Ref. 21	1	Spring	Ressort	Muelle
28		21	Ref. 21	1	Holder	Porte-injecteur	Retén
29		21	Ref. 21	1	Plate	Plaque	Placa
30		21	Ref. 21	1	Valve	Soupape	Válvula
31		21	Ref. 21	3	Ball	Bille	Bola
32		21	Ref. 21	1	Spring	Ressort	Muelle
33		21	Ref. 21	1	Ball	Bille	Bola
34		21	Ref. 21	1	Guide	Guide	Guía
35		21	Ref. 21	1	Cap	Chapeau	Sombbrero
36		21	Ref. 21	2	Bolt	Boulon	Perno
37	6193782M91	2	Anti-cavitation	1	Valve Assy	Ensemble de soupape	Válvula, Conj.
38		37	Ref. 37	1	Valve	Soupape	Válvula
39		38	Ref. 37	1	Kit, Parts	Lot de pièces	Juego de piezas
40		38	Ref. 39	1	O-Ring	Joint torique	Junta de tipo O
41		38	Ref. 39	1	O-Ring	Joint torique	Junta de tipo O
42		38	Ref. 39	1	O-Ring	Joint torique	Junta de tipo O
43	6193774M91	2	Compensator	1	Valve Assy	Ensemble de soupape	Válvula, Conj.
44		43	Ref. 43	1	Plug	Bouchon	Tapón



880
 TX760B TX860B
 TX870B

832 834 842 844 852 854

68008C05.1

6199042M3

1

Jan-06

Loader Controls
Commandes de Chargeur
Mandos de cargadora

Hydraulic Valve
Distributeur de Commande Hydraulique
Distribuidor de mando hidráulico

Loader Arm Section
Élément Bras Chargeur
Elemento brazo cargador

7 in 1 Bucket
 7 in 1 Bucket
 7 in 1 Bucket

C-68008-05.1-A

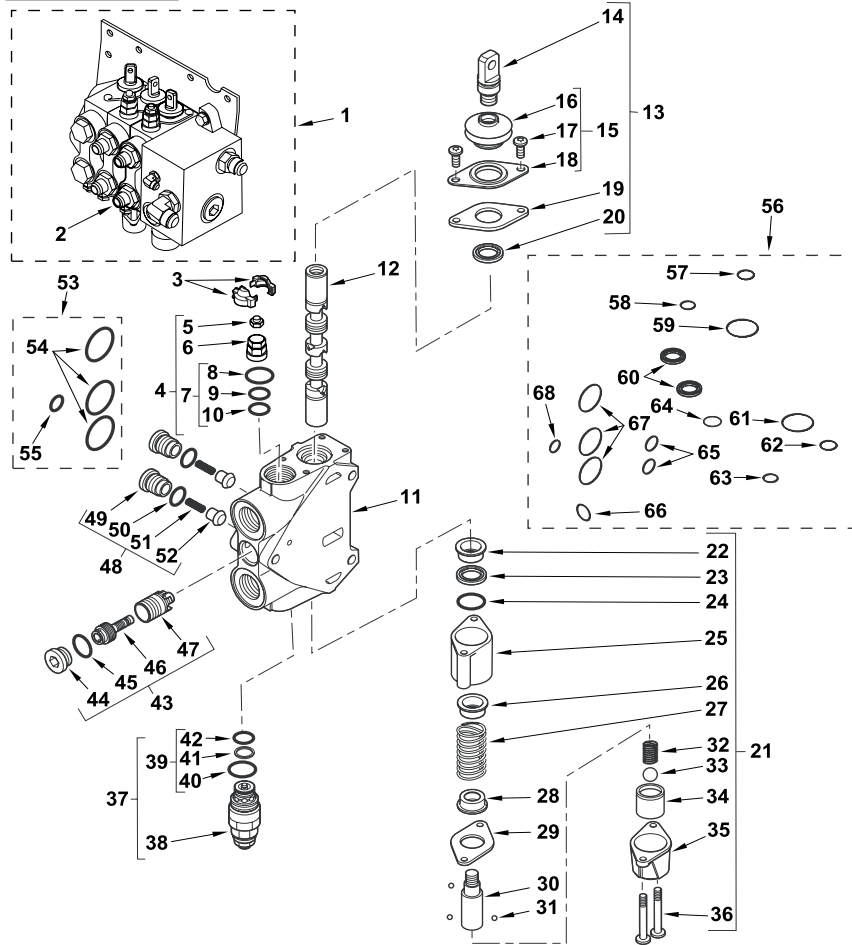

45		43	Ref. 43	1	O-Ring	Joint torique	Junta de tipo O
46		43	Ref. 43	1	Valve	Soupape	Válvula
47		43	Ref. 43	1	Guide	Guide	Guía
48	6193775M91	2		2	Valve, Check	Clapet anti-retour	Válvula de parada
49		48	Ref. 48	1	Plug	Bouchon	Tapón
50		48	Ref. 48	1	O-Ring	Joint torique	Junta de tipo O
51		48	Ref. 48	1	Spring	Ressort	Muelle
52		48	Ref. 48	1	Valve	Soupape	Válvula
53	6193771M91		Interface	X	Kit, Seal	Pochette de joints	Juego de juntas
54		53	Ref. 53	3	O-Ring	Joint torique	Junta de tipo O
55		53	Ref. 53	1	O-Ring	Joint torique	Junta de tipo O
56	6193781M91			X	Kit, Seal	Pochette de joints	Juego de juntas
57		56	18.77 x 1.78 Ref. 56	1	O-Ring	Joint torique	Junta de tipo O
58		56	15.6 x 1.78 Ref. 56	1	O-Ring	Joint torique	Junta de tipo O
59		56	36.3 x 1.78 Ref. 56	1	O-Ring	Joint torique	Junta de tipo O
60	6194492M1	56	Lip	2	Seal	Joint	Junta
61		56	36.3 x 1.78 Ref. 56	1	O-Ring	Joint torique	Junta de tipo O
62		56	18.77 x 1.78 Ref. 56	1	O-Ring	Joint torique	Junta de tipo O
63		56	15.6 x 1.78 Ref. 56	1	O-Ring	Joint torique	Junta de tipo O
64		56	18 x 2.5 Ref. 56	1	O-Ring	Joint torique	Junta de tipo O
65		56	15 x 2 Ref. 56	2	O-Ring	Joint torique	Junta de tipo O
66		56	19.4 x 2.1 Ref. 56	1	O-Ring	Joint torique	Junta de tipo O
67		56	29.82 x 2.62 Ref. 56	3	O-Ring	Joint torique	Junta de tipo O
68		56	10.77 x 2.62 Ref. 56	1	O-Ring	Joint torique	Junta de tipo O

A Part number to be advised
 Référence pièce à demander
 Indicar número de pieza



880
 TX760B TX860B
 TX870B

832 834 842 844 852 854

68008C05.1

6199042M3

1

Jan-06

Loader Controls
Commandes de Chargeur
Mandos de cargadora

Hydraulic Valve
Distributeur de Commande Hydraulique
Distribuidor de mando hidráulico

Standard Bucket Section
Élément de Godet Standard
Elemento de cuchara estándar

7 in 1 Bucket
 7 in 1 Bucket
 7 in 1 Bucket

C-68008-06.1-A

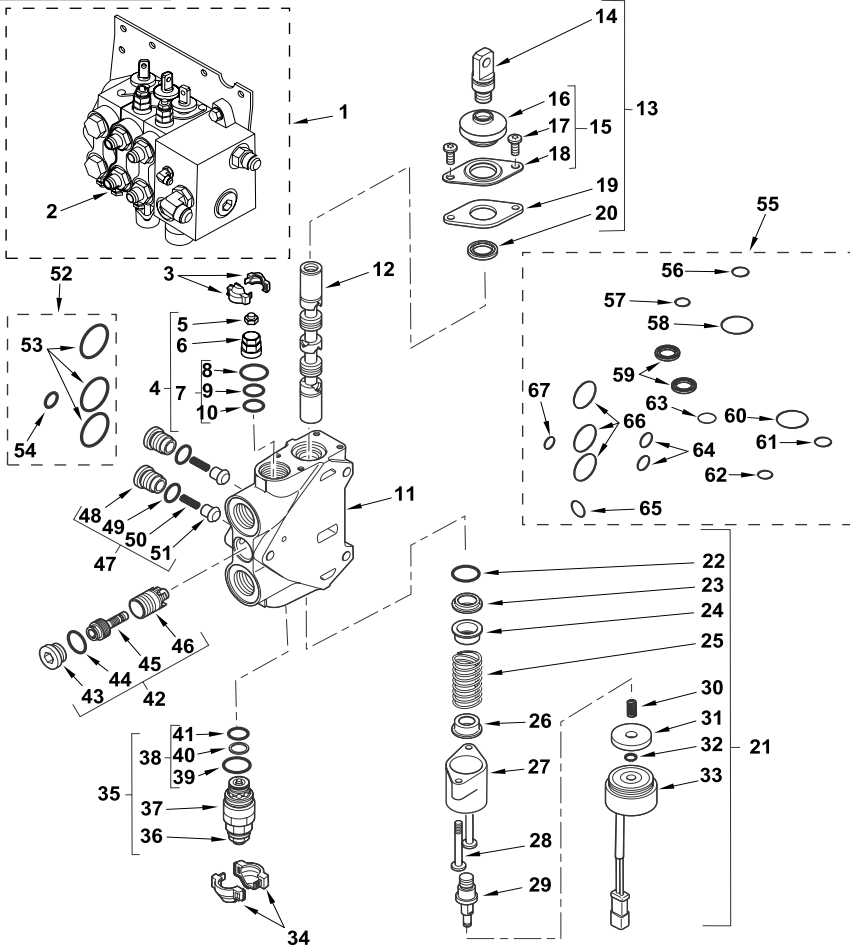

1	6109210M91		Continued 3 Spool	1	Valve Assy, Control	Ensemble distribution	Distribuidor, Conj.
2		1	(A)	1	Valve	Soupape	Válvula
3		2	Ref. 2	X	Cover	Cache	Tapa
4	6193778M91	2		1	Valve, Press. Relief	Soupape de sécurité	Válvula de seguridad
5		4	Ref. 4	1	Nut	Écrou	Tuerca
6		4	Ref. 4	1	Valve	Soupape	Válvula
7	6193779M91	4	Secondary Valves	1	Kit, Seal	Pochette de joints	Juego de juntas
8		7	Ref. 7	1	O-Ring	Joint torique	Junta de tipo O
9		7	Ref. 7	1	O-Ring	Joint torique	Junta de tipo O
10		7	Ref. 7	1	O-Ring	Joint torique	Junta de tipo O
11		2	Ref. 2	1	Body	Corps	Cuerpo
12		2	Ref. 2	1	Spool	Tiroir	Cajoncillo
13	6193780M91	2	Mech. Optd Z1	1	Kit, Parts	Lot de pièces	Juego de piezas
14		13	Ref. 13	1	Screw	Vis	Tornillo
15	6193783M91	13	Ref. 13 Bellows	1	Kit, Parts	Lot de pièces	Juego de piezas
16		15	Ref. 15	1	Seal	Joint	Junta
17		15	Ref. 15	2	Screw	Vis	Tornillo
18		15	Ref. 15	1	Cover	Cache	Tapa
19		13	Ref. 13	1	Plate	Plaque	Placa
20	6194492M1	13	Lip	1	Seal	Joint	Junta
21	6193798M91	2	Elect. Detent S2	1	Kit, Parts	Lot de pièces	Juego de piezas
22		21	Ref. 21	1	O-Ring	Joint torique	Junta de tipo O
23	6194492M1	21	Lip	1	Seal	Joint	Junta
24		21	Ref. 21	1	Holder	Porte-injecteur	Retén
25		21	Ref. 21	1	Spring	Ressort	Muelle
26		21	Ref. 21	1	Holder	Porte-injecteur	Retén
27		21	Ref. 21	1	Cap	Chapeau	Sombbrero
28		21	Ref. 21	2	Bolt	Boulon	Perno
29		21	Ref. 21	1	Screw	Vis	Tornillo
30		21	Ref. 21	1	Spring	Ressort	Muelle
31		21	Ref. 21	1	Washer	Rondelle	Arandela
32		21	Ref. 21	1	O-Ring	Joint torique	Junta de tipo O
33		21	Ref. 21	1	Harness	Faisceau	Haz
34		2	Ref. 2	X	Cover	Cache	Tapa
35	6193778M91	2		1	Valve, Press. Relief	Soupape de sécurité	Válvula de seguridad
36		35	Ref. 35	1	Nut	Écrou	Tuerca
37		35	Ref. 35	1	Valve	Soupape	Válvula
38		38	Ref. 35	1	Kit, Parts	Lot de pièces	Juego de piezas
39		38	Ref. 37	1	O-Ring	Joint torique	Junta de tipo O
40		38	Ref. 37	1	O-Ring	Joint torique	Junta de tipo O
41		38	Ref. 37	1	O-Ring	Joint torique	Junta de tipo O
42	6193774M91	2	Compensator	1	Valve Assy	Ensemble de soupape	Válvula, Conj.
43		42	Ref. 42	1	Plug	Bouchon	Tapón
44		42	Ref. 42	1	O-Ring	Joint torique	Junta de tipo O



880
 TX760B TX860B
 TX870B

832 834 842 844 852 854

68008C06.1

6199042M3

1

Jan-06

Loader Controls
Commandes de Chargeur
Mandos de cargadora

Hydraulic Valve
Distributeur de Commande Hydraulique
Distribuidor de mando hidráulico

Standard Bucket Section
Élément de Godet Standard
Elemento de cuchara estándar

7 in 1 Bucket
 7 in 1 Bucket
 7 in 1 Bucket

C-68008-06.1-A

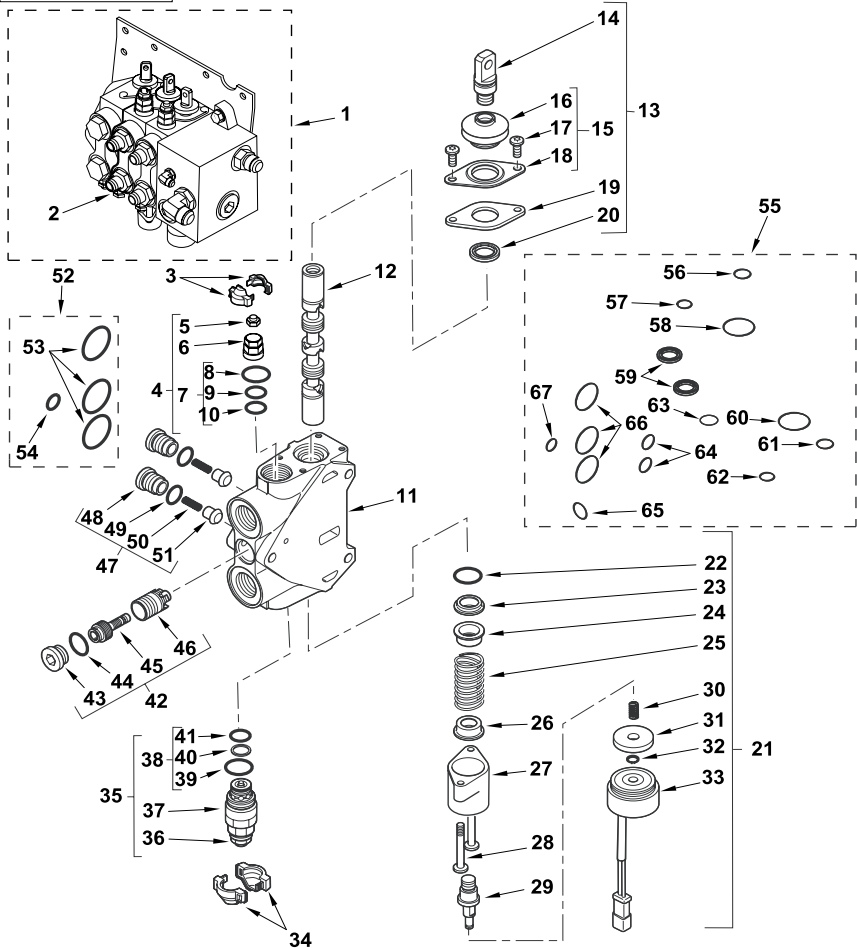

45			1	Valve	Soupape	Válvula
46			1	Guide	Guide	Guía
47	6193775M91	2	2	Valve, Check	Clapet anti-retour	Válvula de parada
48			1	Plug	Bouchon	Tapón
49			1	O-Ring	Joint torique	Junta de tipo O
50			1	Spring	Ressort	Muelle
51			1	Valve	Soupape	Válvula
52	6193771M91	Interface	X	Kit, Seal	Pochette de joints	Juego de juntas
53			3	O-Ring	Joint torique	Junta de tipo O
54			1	O-Ring	Joint torique	Junta de tipo O
55	6193781M91		X	Kit, Seal	Pochette de joints	Juego de juntas
56		18.77 x 1.78	1	O-Ring	Joint torique	Junta de tipo O
57		15.6 x 1.78	1	O-Ring	Joint torique	Junta de tipo O
58		36.3 x 1.78	1	O-Ring	Joint torique	Junta de tipo O
59	6194492M1	55 Lip	2	Seal	Joint	Junta
60		36.3 x 1.78	1	O-Ring	Joint torique	Junta de tipo O
61		18.77 x 1.78	1	O-Ring	Joint torique	Junta de tipo O
62		15.6 x 1.78	1	O-Ring	Joint torique	Junta de tipo O
63		18 x 2.5	1	O-Ring	Joint torique	Junta de tipo O
64		15 x 2	2	O-Ring	Joint torique	Junta de tipo O
65		19.4 x 2.1	1	O-Ring	Joint torique	Junta de tipo O
66		29.82 x 2.62	3	O-Ring	Joint torique	Junta de tipo O
67		10.77 x 2.62	1	O-Ring	Joint torique	Junta de tipo O

A Part number to be advised
 Référence pièce à demander
 Indicar número de pieza



880
 TX760B TX860B
 TX870B

832 834 842 844 852 854

68008C06.1

6199042M3

1

Jan-06

Loader Controls
Commandes de Chargeur
Mandos de cargadora

Hydraulic Valve
Distributeur de Commande Hydraulique
Distribuidor de mando hidráulico

Bucket Section, 7 In-1
Élément de Godet 7-en-1
Elemento de cuchara 7 x 1

7 in 1 Bucket
 7 in 1 Bucket
 7 in 1 Bucket

C-68008-07.1-A

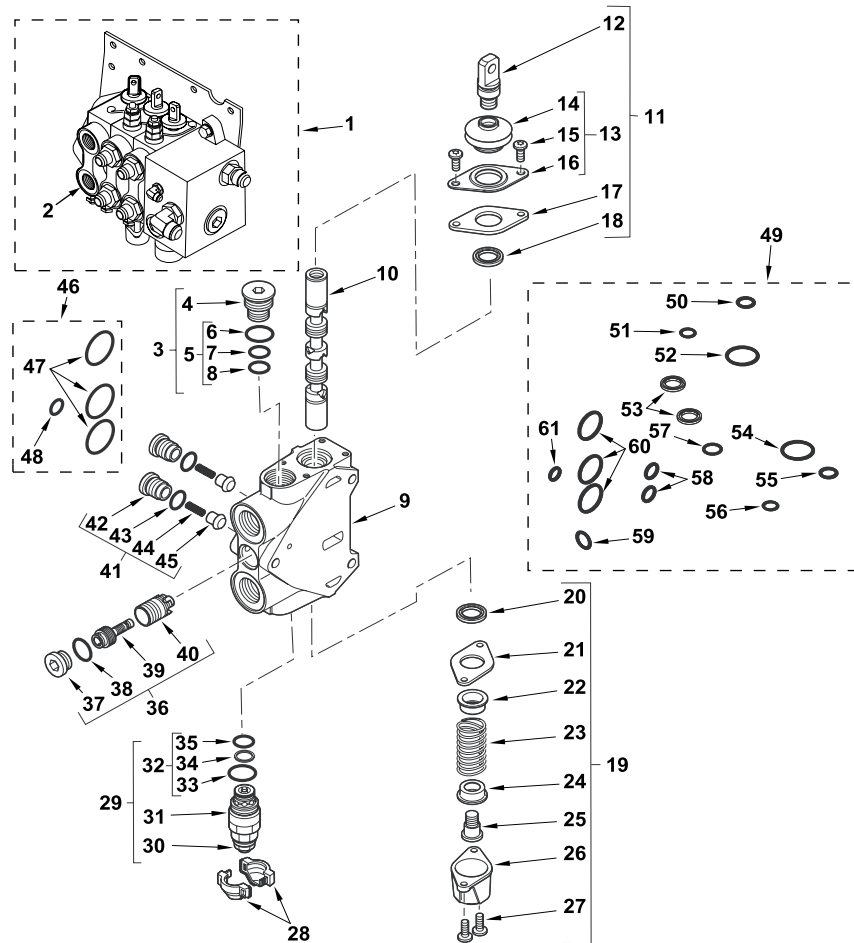

1	6109210M91		Continued 3 Spool	1	Valve Assy, Control	Ensemble distribution	Distribuidor, Conj.
2		1	(A)	1	Valve	Soupape	Válvula
3	6193785M91	2		1	Plug Assy	Ensemble bouchons	Tapón, Conj.
4		3	Ref. 3	1	Plug	Bouchon	Tapón
5	6193779M91	3	Secondary Valves	1	Kit, Seal	Pochette de joints	Juego de juntas
6		5	Ref. 5	1	O-Ring	Joint torique	Junta de tipo O
7		5	Ref. 5	1	O-Ring	Joint torique	Junta de tipo O
8		5	Ref. 5	1	O-Ring	Joint torique	Junta de tipo O
9		2	Ref. 2	1	Body	Corps	Cuerpo
10		2	Ref. 2	1	Spool	Tiroir	Cajoncillo
11	6193780M91	2	Mech. Optd Z1	1	Kit, Parts	Lot de pièces	Juego de piezas
12		11	Ref. 11	1	Screw	Vis	Tornillo
13	6193783M91	11	Ref. 11 Bellows	1	Kit, Parts	Lot de pièces	Juego de piezas
14		13	Ref. 13	1	Seal	Joint	Junta
15		13	Ref. 13	2	Screw	Vis	Tornillo
16		13	Ref. 13	1	Cover	Cache	Tapa
17		11	Ref. 11	1	Plate	Plaque	Placa
18	6194492M1	11	Lip	1	Seal	Joint	Junta
19	6193784M91	2	Mech Optd A2	1	Kit, Parts	Lot de pièces	Juego de piezas
20	6194492M1	21	Lip	1	Seal	Joint	Junta
21		21	Ref. 21	1	Plate	Plaque	Placa
22		21	Ref. 21	1	Holder	Porte-injecteur	Retén
23		21	Ref. 21	1	Spring	Ressort	Muelle
24		21	Ref. 21	1	Holder	Porte-injecteur	Retén
25		21	Ref. 21	1	Screw	Vis	Tornillo
26		21	Ref. 21	1	Cap	Chapeau	Sombbrero
27		21	Ref. 21	2	Bolt	Boulon	Perno
28		2	Ref. 2	X	Cover	Cache	Tapa
29	6193778M91	2		1	Valve, Press. Relief	Soupape de sécurité	Válvula de seguridad
30		29	Ref. 29	1	Nut	Écrou	Tuerca
31		29	Ref. 29	1	Valve	Soupape	Válvula
32	6193779M91	29	Ref. 29 Secondary Valves	1	Kit, Seal	Pochette de joints	Juego de juntas
33		32	Ref. 32	1	O-Ring	Joint torique	Junta de tipo O
34		32	Ref. 32	1	O-Ring	Joint torique	Junta de tipo O
35		32	Ref. 32	1	O-Ring	Joint torique	Junta de tipo O
36	6193774M91	2	Compensator	1	Valve Assy	Ensemble de soupape	Válvula, Conj.
37		36	Ref. 36	1	Plug	Bouchon	Tapón
38		36	Ref. 36	1	O-Ring	Joint torique	Junta de tipo O
39		36	Ref. 36	1	Valve	Soupape	Válvula
40		36	Ref. 36	1	Guide	Guide	Guía
41	6193775M91	2		2	Valve, Check	Clapet anti-retour	Válvula de parada
42		41	Ref. 41	1	Plug	Bouchon	Tapón
43		41	Ref. 41	1	O-Ring	Joint torique	Junta de tipo O



880
 TX760B TX860B
 TX870B

832 834 842 844 852 854

68008C07.1

6199042M3

1

Jan-06

Loader Controls
Commandes de Chargeur
Mandos de cargadora

Hydraulic Valve
Distributeur de Commande Hydraulique
Distribuidor de mando hidráulico

Bucket Section, 7 In-1
Élément de Godet 7-en-1
Elemento de cuchara 7 x 1

7 in 1 Bucket
7 in 1 Bucket
7 in 1 Bucket

C-68008-07.1-A

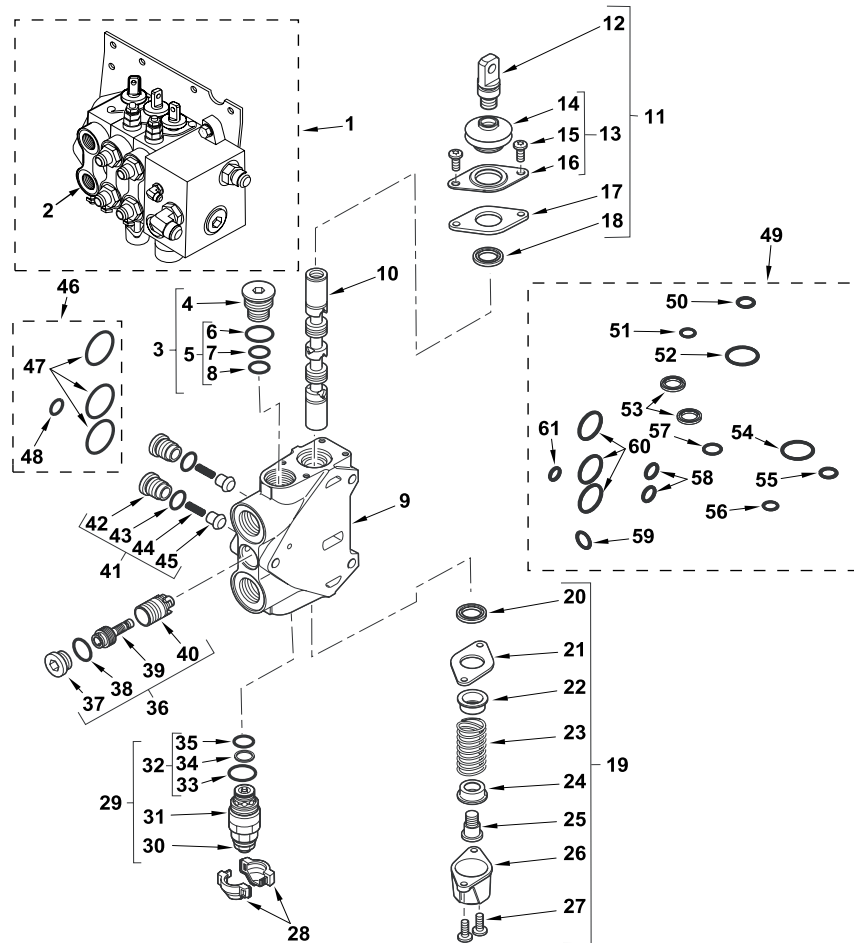

44		41	Ref. 41	1	Spring	Ressort	Muelle
45		41	Ref. 41	1	Valve	Soupape	Válvula
46	6193771M91		Interface	X	Kit, Seal	Pochette de joints	Juego de juntas
47		46	Ref. 46	3	O-Ring	Joint torique	Junta de tipo O
48		46	Ref. 46	1	O-Ring	Joint torique	Junta de tipo O
49	6193781M91			X	Kit, Seal	Pochette de joints	Juego de juntas
50		49	18.77 x 1.78 Ref. 49	1	O-Ring	Joint torique	Junta de tipo O
51		49	15.6 x 1.78 Ref. 49	1	O-Ring	Joint torique	Junta de tipo O
52		49	36.3 x 1.78 Ref. 49	1	O-Ring	Joint torique	Junta de tipo O
53	6194492M1	49	Lip	2	Seal	Joint	Junta
54		49	36.3 x 1.78 Ref. 49	1	O-Ring	Joint torique	Junta de tipo O
55		49	18.77 x 1.78 Ref. 49	1	O-Ring	Joint torique	Junta de tipo O
56		49	15.6 x 1.78 Ref. 49	1	O-Ring	Joint torique	Junta de tipo O
57		49	18 x 2.5 Ref. 49	1	O-Ring	Joint torique	Junta de tipo O
58		49	15 x 2 Ref. 49	2	O-Ring	Joint torique	Junta de tipo O
59		49	19.4 x 2.1 Ref. 49	1	O-Ring	Joint torique	Junta de tipo O
60		49	29.82 x 2.62 Ref. 49	3	O-Ring	Joint torique	Junta de tipo O
61		49	10.77 x 2.62 Ref. 49	1	O-Ring	Joint torique	Junta de tipo O

A Part number to be advised
 Référence pièce à demander
 Indicar número de pieza



880
 TX760B TX860B
 TX870B

832 834 842 844 852 854

68008C07.1

6199042M3

1

Jan-06

Loader Controls
Commandes de Chargeur
Mandos de cargadora

Hydraulic Valve
Distributeur de Commande Hydraulique
Distribuidor de mando hidráulico

Outlet
Deversoir
Salida

7 in 1 Bucket
7 in 1 Bucket
7 in 1 Bucket

C-68008-08.1-A

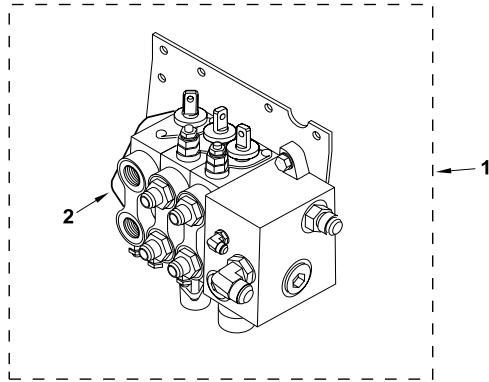

1	6109210M91	3 Spool	1	Valve Assy, Control	Ensemble distribution	Distribuidor, Conj.
2		1 (A)	1	Valve	Soupape	Válvula
3		2  Ref. 2	1	Cover	Cache	Tapa
4		2  Ref. 2	3	Rod Assy	Ensemble tringlerie	Tirantes, Conj.
5		4  Ref. 4	1	Rod	Tringle	Vástago
6		4  Ref. 4	1	Nut	Écrou	Tuerca
7	6193771M91	Interface	X	Kit, Seal	Pochette de joints	Juego de juntas
8		7  Ref. 7	3	O-Ring	Joint torique	Junta de tipo O
9		7  Ref. 7	1	O-Ring	Joint torique	Junta de tipo O

A Part number to be advised
Référence pièce à demander
Indicar número de pieza

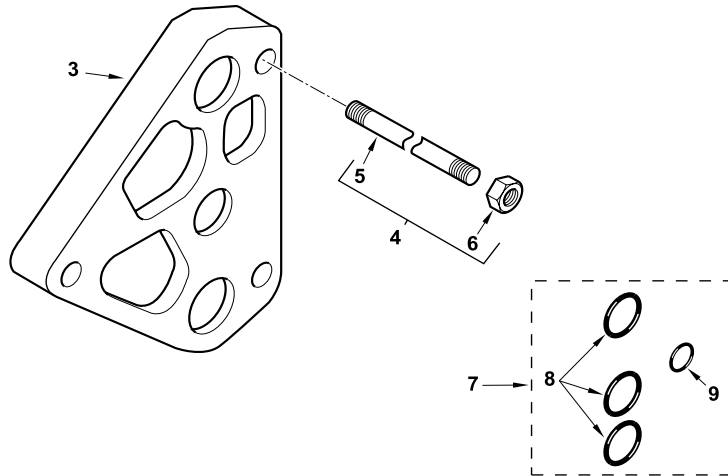

880
TX760B TX860B
TX870B

832 834 842 844 852 854

68008C08.1

6199042M3

1

Jan-06





Loader Controls
Commandes de Chargeur
Mandos de cargadora

Hydraulic Valve
Distributeur de Commande Hydraulique
Distribuidor de mando hidráulico

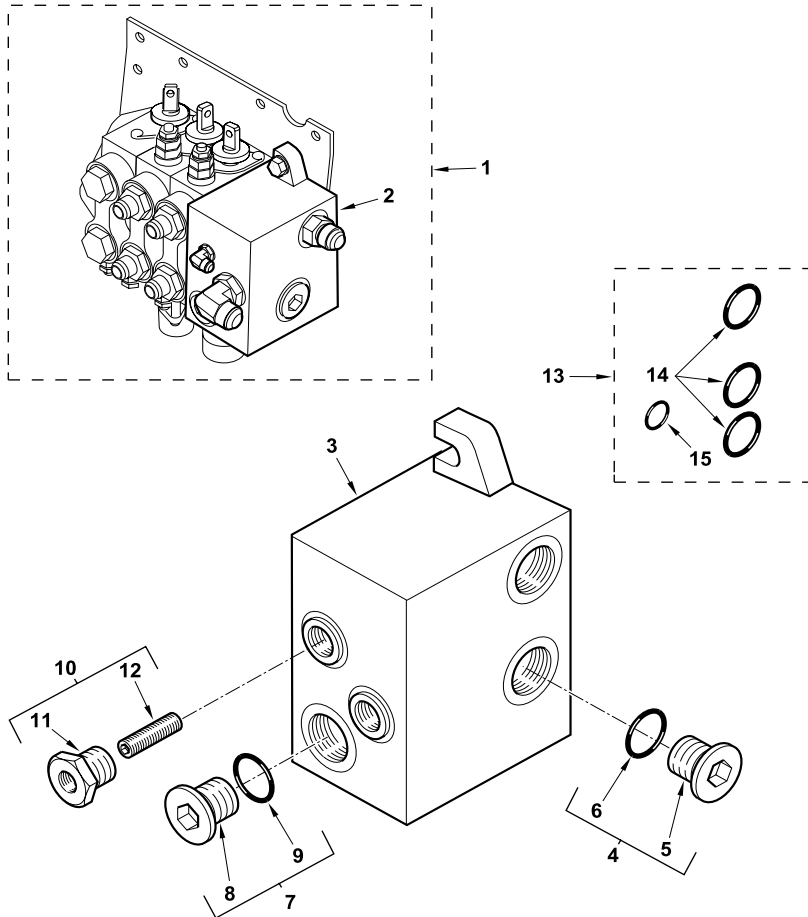
Inlet
Admission
Admision

C-68009-04.1-A



1	6109210M91	3 Spool	1	Valve Assy, Control	Ensemble distribution	Distribuidor, Conj.
2		1 (A)Inlet	1	Valve	Soupape	Válvula
3		2	1	Body	Corps	Cuerpo
4	6193773M91	2 1 1/16" UNF	1	Plug Assy	Ensemble bouchons	Tapón, Conj.
5		4  Ref. 4	1	Plug	Bouchon	Tapón
6		4  Ref. 4	1	O-Ring	Joint torique	Junta de tipo O
7	6193772M91	2 5/16" UNF	1	Plug Assy	Ensemble bouchons	Tapón, Conj.
8		7  Ref. 7	1	Plug	Bouchon	Tapón
9		7  Ref. 7	1	O-Ring	Joint torique	Junta de tipo O
10	6193770M91	2	1	Valve Assy	Ensemble de soupape	Válvula, Conj.
11		10  Ref. 10	1	Valve	Soupape	Válvula
12		10  Ref. 10	1	Spring	Ressort	Muelle
13	6193771M91	Interface	X	Kit, Seal	Pochette de joints	Juego de juntas
14		13  Ref. 13	3	O-Ring	Joint torique	Junta de tipo O
15		13  Ref. 13	1	O-Ring	Joint torique	Junta de tipo O

A Part number to be advised
 Référence pièce à demander
 Indicar número de pieza



880
 TX760B TX860B
 TX870B

832 834 842 844 852 854

68009C04.1

6199042M3

1

Jan-06

Loader Controls
Commandes de Chargeur
Mandos de cargadora

Hydraulic Valve
Distributeur de Commande Hydraulique
Distribuidor de mando hidráulico

Loader Arm Section
Élément Bras Chargeur
Elemento brazo cargador

C-68009-05.1-A

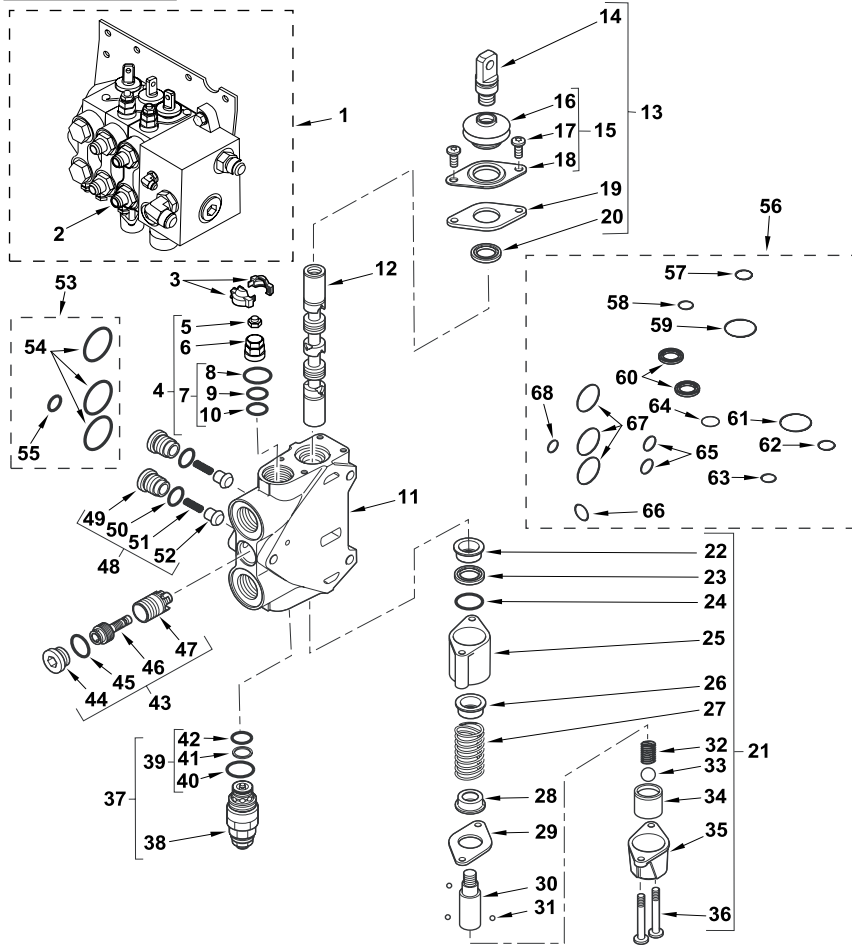

1	6109210M91		Continued 3 Spool	1	Valve Assy, Control	Ensemble distribution	Distribuidor, Conj.
2		1	(A)	1	Valve	Soupape	Válvula
3		2	Ref. 2	X	Cover	Cache	Tapa
4	6193778M91	2		1	Valve, Press. Relief	Soupape de sécurité	Válvula de seguridad
5		4	Ref. 4	1	Nut	Écrou	Tuerca
6		4	Ref. 4	1	Valve	Soupape	Válvula
7	6193779M91	4	Secondary Valves	1	Kit, Seal	Pochette de joints	Juego de juntas
8		7	Ref. 7	1	O-Ring	Joint torique	Junta de tipo O
9		7	Ref. 7	1	O-Ring	Joint torique	Junta de tipo O
10		7	Ref. 7	1	O-Ring	Joint torique	Junta de tipo O
11		2	Ref. 2	1	Body	Corps	Cuerpo
12		2	Ref. 2	1	Spool	Tiroir	Cajoncillo
13	6193780M91	2	Mech. Optd Z1	1	Kit, Parts	Lot de pièces	Juego de piezas
14		13	Ref. 13	1	Screw	Vis	Tornillo
15	6193783M91	13	Bellows	1	Kit, Parts	Lot de pièces	Juego de piezas
16		15	Ref. 15	1	Seal	Joint	Junta
17		15	Ref. 15	2	Screw	Vis	Tornillo
18		15	Ref. 15	1	Cover	Cache	Tapa
19		13	Ref. 13	1	Plate	Plaque	Placa
20	6194492M1	13	Lip	1	Seal	Joint	Junta
21	6193797M91	2	Mech. Optd E2	1	Kit, Parts	Lot de pièces	Juego de piezas
22		21	Ref. 21	1	Guide	Guide	Guía
23	6194492M1	21	Lip	1	Seal	Joint	Junta
24		21	Ref. 21	1	O-Ring	Joint torique	Junta de tipo O
25		21	Ref. 21	1	Body	Corps	Cuerpo
26		21	Ref. 21	1	Holder	Porte-injecteur	Retén
27		21	Ref. 21	1	Spring	Ressort	Muelle
28		21	Ref. 21	1	Holder	Porte-injecteur	Retén
29		21	Ref. 21	1	Plate	Plaque	Placa
30		21	Ref. 21	1	Valve	Soupape	Válvula
31		21	Ref. 21	3	Ball	Bille	Bola
32		21	Ref. 21	1	Spring	Ressort	Muelle
33		21	Ref. 21	1	Ball	Bille	Bola
34		21	Ref. 21	1	Guide	Guide	Guía
35		21	Ref. 21	1	Cap	Chapeau	Sombbrero
36		21	Ref. 21	2	Bolt	Boulon	Perno
37	6193782M91	2	Anti-cavitation	1	Valve Assy	Ensemble de soupape	Válvula, Conj.
38		37	Ref. 37	1	Valve	Soupape	Válvula
39		38	Ref. 37	1	Kit, Parts	Lot de pièces	Juego de piezas
40		38	Ref. 39	1	O-Ring	Joint torique	Junta de tipo O
41		38	Ref. 39	1	O-Ring	Joint torique	Junta de tipo O
42		38	Ref. 39	1	O-Ring	Joint torique	Junta de tipo O
43	6193774M91	2	Compensator	1	Valve Assy	Ensemble de soupape	Válvula, Conj.
44		43	Ref. 43	1	Plug	Bouchon	Tapón



880
 TX760B TX860B
 TX870B

832 834 842 844 852 854

68009C05.1

6199042M3

1

Jan-06

Loader Controls
Commandes de Chargeur
Mandos de cargadora

Hydraulic Valve
Distributeur de Commande Hydraulique
Distribuidor de mando hidráulico

Loader Arm Section
Élément Bras Chargeur
Elemento brazo cargador

C-68009-05.1-A

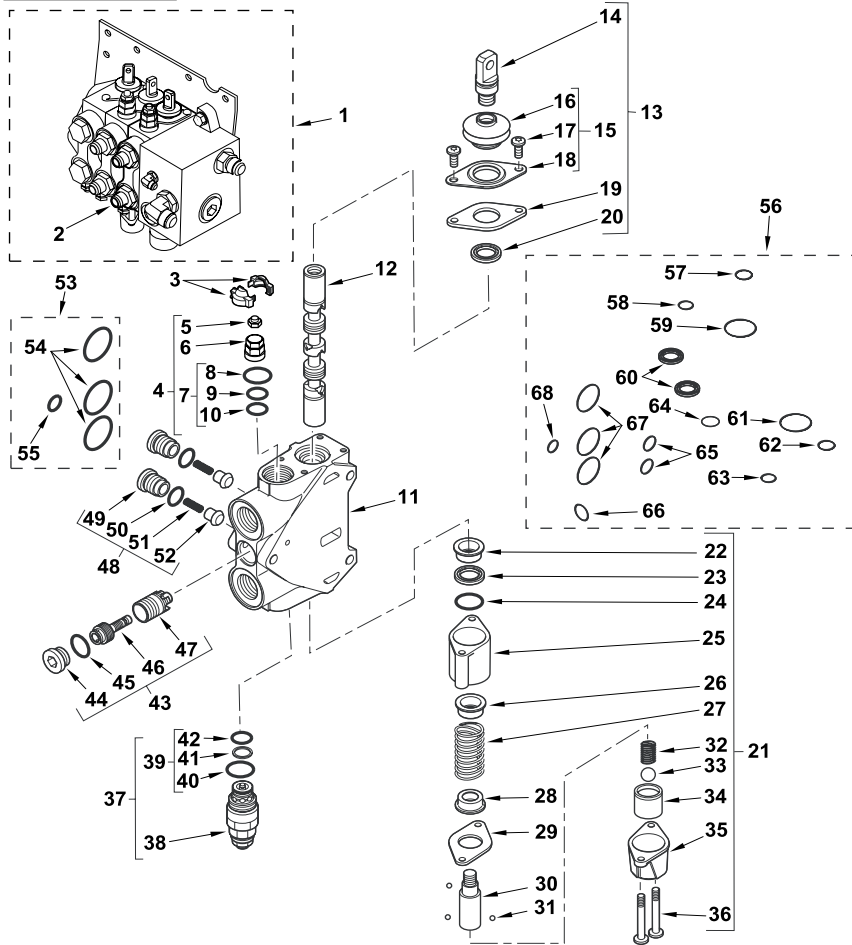

45		43	Ref. 43	1	O-Ring	Joint torique	Junta de tipo O
46		43	Ref. 43	1	Valve	Soupape	Válvula
47		43	Ref. 43	1	Guide	Guide	Guía
48	6193775M91	2		2	Valve, Check	Clapet anti-retour	Válvula de parada
49		48	Ref. 48	1	Plug	Bouchon	Tapón
50		48	Ref. 48	1	O-Ring	Joint torique	Junta de tipo O
51		48	Ref. 48	1	Spring	Ressort	Muelle
52		48	Ref. 48	1	Valve	Soupape	Válvula
53	6193771M91		Interface	X	Kit, Seal	Pochette de joints	Juego de juntas
54		53	Ref. 53	3	O-Ring	Joint torique	Junta de tipo O
55		53	Ref. 53	1	O-Ring	Joint torique	Junta de tipo O
56	6193781M91			X	Kit, Seal	Pochette de joints	Juego de juntas
57		56	18.77 x 1.78 Ref. 56	1	O-Ring	Joint torique	Junta de tipo O
58		56	15.6 x 1.78 Ref. 56	1	O-Ring	Joint torique	Junta de tipo O
59		56	36.3 x 1.78 Ref. 56	1	O-Ring	Joint torique	Junta de tipo O
60	6194492M1	56	Lip	2	Seal	Joint	Junta
61		56	36.3 x 1.78 Ref. 56	1	O-Ring	Joint torique	Junta de tipo O
62		56	18.77 x 1.78 Ref. 56	1	O-Ring	Joint torique	Junta de tipo O
63		56	15.6 x 1.78 Ref. 56	1	O-Ring	Joint torique	Junta de tipo O
64		56	18 x 2.5 Ref. 56	1	O-Ring	Joint torique	Junta de tipo O
65		56	15 x 2 Ref. 56	2	O-Ring	Joint torique	Junta de tipo O
66		56	19.4 x 2.1 Ref. 56	1	O-Ring	Joint torique	Junta de tipo O
67		56	29.82 x 2.62 Ref. 56	3	O-Ring	Joint torique	Junta de tipo O
68		56	10.77 x 2.62 Ref. 56	1	O-Ring	Joint torique	Junta de tipo O

A Part number to be advised
 Référence pièce à demander
 Indicar número de pieza



880
 TX760B TX860B
 TX870B

832 834 842 844 852 854

68009C05.1

6199042M3

1

Jan-06

Loader Controls
Commandes de Chargeur
Mandos de cargadora

Hydraulic Valve
Distributeur de Commande Hydraulique
Distribuidor de mando hidráulico

Standard Bucket Section
Élément de Godet Standard
Elemento de cuchara estándar

C-68009-06.1-A

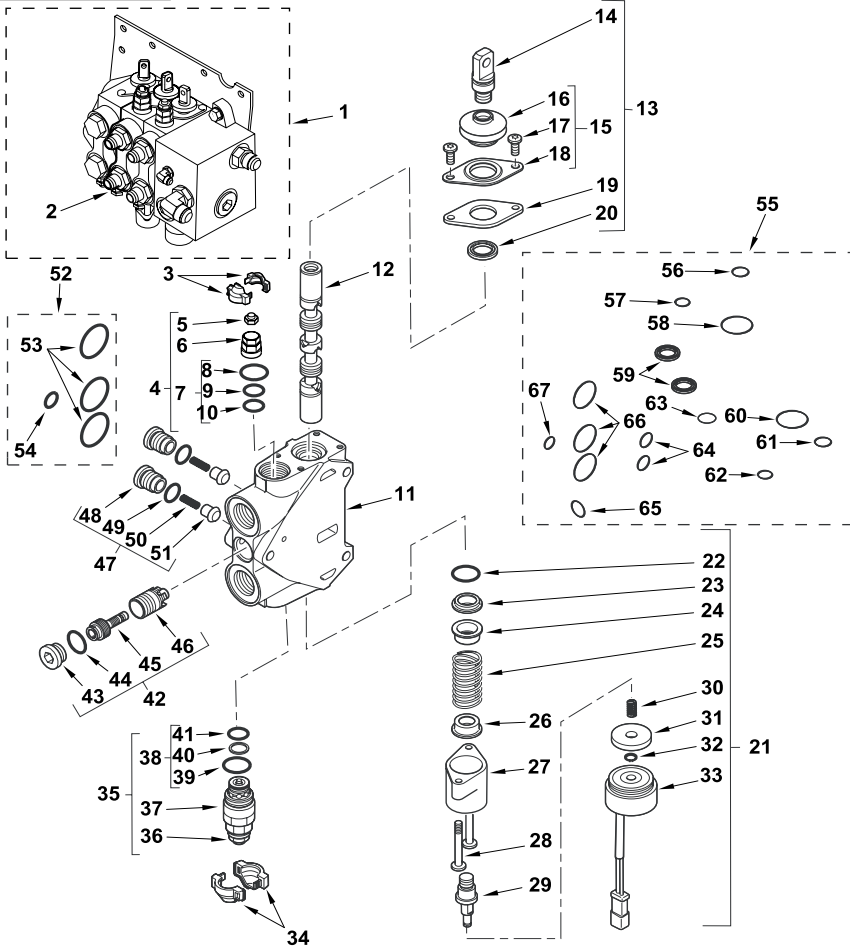

1	6109210M91		Continued 3 Spool	1	Valve Assy, Control	Ensemble distribution	Distribuidor, Conj.
2		1	(A)	1	Valve	Soupape	Válvula
3		2	Ref. 2	X	Cover	Cache	Tapa
4	6193778M91	2		1	Valve, Press. Relief	Soupape de sécurité	Válvula de seguridad
5		4	Ref. 4	1	Nut	Écrou	Tuerca
6		4	Ref. 4	1	Valve	Soupape	Válvula
7	6193779M91	4	Secondary Valves	1	Kit, Seal	Pochette de joints	Juego de juntas
8		7	Ref. 7	1	O-Ring	Joint torique	Junta de tipo O
9		7	Ref. 7	1	O-Ring	Joint torique	Junta de tipo O
10		7	Ref. 7	1	O-Ring	Joint torique	Junta de tipo O
11		2	Ref. 2	1	Body	Corps	Cuerpo
12		2	Ref. 2	1	Spool	Tiroir	Cajoncillo
13	6193780M91	2	Mech. Optd Z1	1	Kit, Parts	Lot de pièces	Juego de piezas
14		13	Ref. 13	1	Screw	Vis	Tornillo
15	6193783M91	13	Bellows	1	Kit, Parts	Lot de pièces	Juego de piezas
16		15	Ref. 15	1	Seal	Joint	Junta
17		15	Ref. 15	2	Screw	Vis	Tornillo
18		15	Ref. 15	1	Cover	Cache	Tapa
19		13	Ref. 13	1	Plate	Plaque	Placa
20	6194492M1	13	Lip	1	Seal	Joint	Junta
21	6193798M91	2	Elect. Detent S2	1	Kit, Parts	Lot de pièces	Juego de piezas
22		21	Ref. 21	1	O-Ring	Joint torique	Junta de tipo O
23	6194492M1	21	Lip	1	Seal	Joint	Junta
24		21	Ref. 21	1	Holder	Porte-injecteur	Retén
25		21	Ref. 21	1	Spring	Ressort	Muelle
26		21	Ref. 21	1	Holder	Porte-injecteur	Retén
27		21	Ref. 21	1	Cap	Chapeau	Sombbrero
28		21	Ref. 21	2	Bolt	Boulon	Perno
29		21	Ref. 21	1	Screw	Vis	Tornillo
30		21	Ref. 21	1	Spring	Ressort	Muelle
31		21	Ref. 21	1	Washer	Rondelle	Arandela
32		21	Ref. 21	1	O-Ring	Joint torique	Junta de tipo O
33		21	Ref. 21	1	Harness	Faisceau	Haz
34		2	Ref. 2	X	Cover	Cache	Tapa
35	6193778M91	2		1	Valve, Press. Relief	Soupape de sécurité	Válvula de seguridad
36		35	Ref. 35	1	Nut	Écrou	Tuerca
37		35	Ref. 35	1	Valve	Soupape	Válvula
38		38	Ref. 35	1	Kit, Parts	Lot de pièces	Juego de piezas
39		38	Ref. 37	1	O-Ring	Joint torique	Junta de tipo O
40		38	Ref. 37	1	O-Ring	Joint torique	Junta de tipo O
41		38	Ref. 37	1	O-Ring	Joint torique	Junta de tipo O
42	6193774M91	2	Compensator	1	Valve Assy	Ensemble de soupape	Válvula, Conj.
43		42	Ref. 42	1	Plug	Bouchon	Tapón
44		42	Ref. 42	1	O-Ring	Joint torique	Junta de tipo O



880
 TX760B TX860B
 TX870B

832 834 842 844 852 854

68009C06.1

6199042M3

1

Jan-06

Loader Controls
Commandes de Chargeur
Mandos de cargadora

Hydraulic Valve
Distributeur de Commande Hydraulique
Distribuidor de mando hidráulico

Standard Bucket Section
Élément de Godet Standard
Elemento de cuchara estándar

C-68009-06.1-A

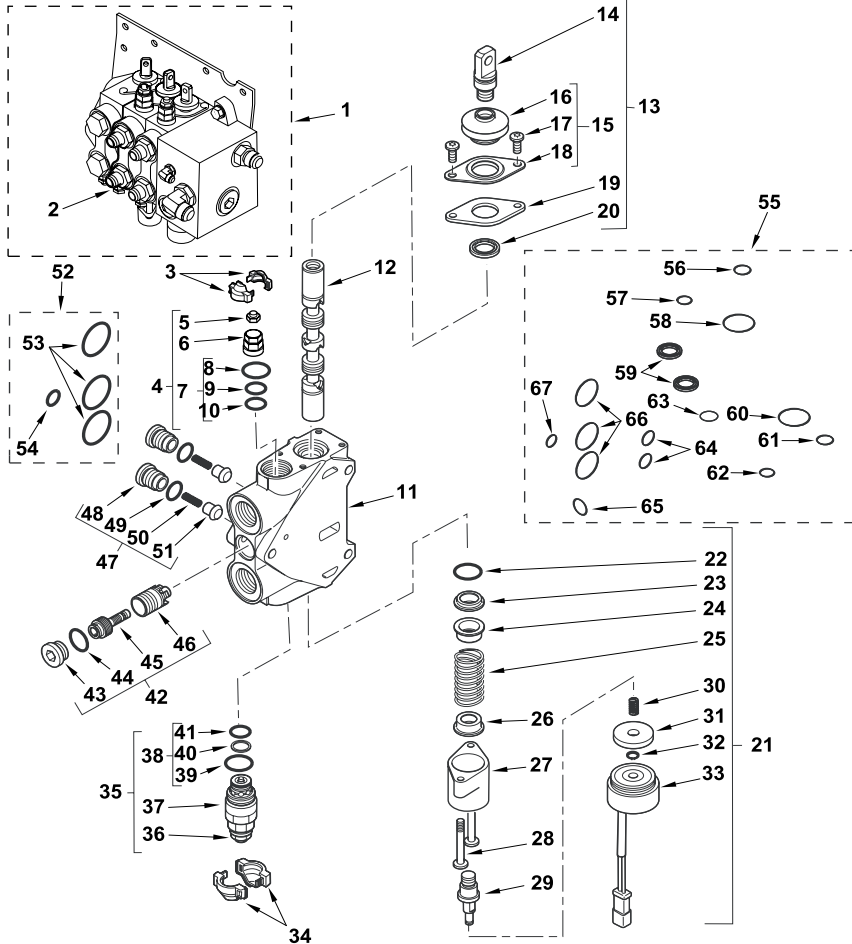

45			1	Valve	Soupape	Válvula
46			1	Guide	Guide	Guía
47	6193775M91	2	2	Valve, Check	Clapet anti-retour	Válvula de parada
48			1	Plug	Bouchon	Tapón
49			1	O-Ring	Joint torique	Junta de tipo O
50			1	Spring	Ressort	Muelle
51			1	Valve	Soupape	Válvula
52	6193771M91	Interface	X	Kit, Seal	Pochette de joints	Juego de juntas
53			3	O-Ring	Joint torique	Junta de tipo O
54			1	O-Ring	Joint torique	Junta de tipo O
55	6193781M91		X	Kit, Seal	Pochette de joints	Juego de juntas
56		18.77 x 1.78	1	O-Ring	Joint torique	Junta de tipo O
57		15.6 x 1.78	1	O-Ring	Joint torique	Junta de tipo O
58		36.3 x 1.78	1	O-Ring	Joint torique	Junta de tipo O
59	6194492M1	55 Lip	2	Seal	Joint	Junta
60		36.3 x 1.78	1	O-Ring	Joint torique	Junta de tipo O
61		18.77 x 1.78	1	O-Ring	Joint torique	Junta de tipo O
62		15.6 x 1.78	1	O-Ring	Joint torique	Junta de tipo O
63		18 x 2.5	1	O-Ring	Joint torique	Junta de tipo O
64		15 x 2	2	O-Ring	Joint torique	Junta de tipo O
65		19.4 x 2.1	1	O-Ring	Joint torique	Junta de tipo O
66		29.82 x 2.62	3	O-Ring	Joint torique	Junta de tipo O
67		10.77 x 2.62	1	O-Ring	Joint torique	Junta de tipo O

A Part number to be advised
 Référence pièce à demander
 Indicar número de pieza



880
 TX760B TX860B
 TX870B

832 834 842 844 852 854

68009C06.1

6199042M3

1

Jan-06

Loader Controls
Commandes de Chargeur
Mandos de cargadora

Hydraulic Valve
Distributeur de Commande Hydraulique
Distribuidor de mando hidráulico

Bucket Section, 7 In-1
Élément de Godet 7-en-1
Elemento de cuchara 7 x 1

C-68009-07.1-A

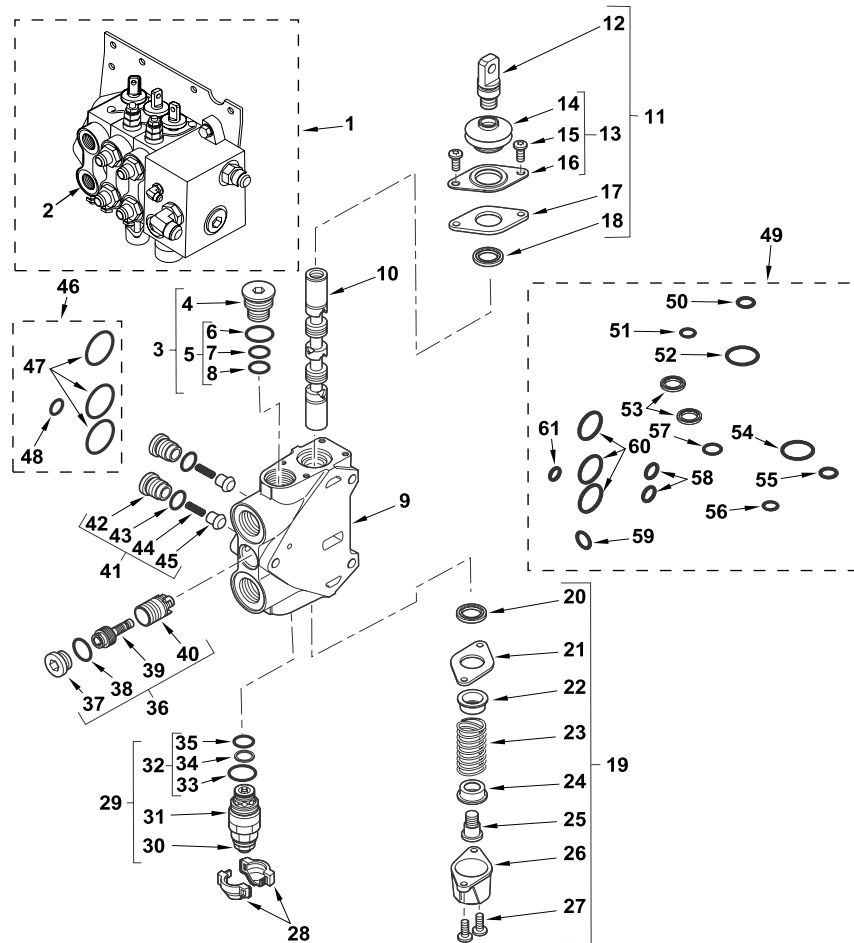

1	6109210M91		Continued 3 Spool	1	Valve Assy, Control	Ensemble distribution	Distribuidor, Conj.
2		1	(A)	1	Valve	Soupape	Válvula
3	6193785M91	2		1	Plug Assy	Ensemble bouchons	Tapón, Conj.
4		3	Ref. 3	1	Plug	Bouchon	Tapón
5	6193779M91	3	Secondary Valves	1	Kit, Seal	Pochette de joints	Juego de juntas
6		5	Ref. 5	1	O-Ring	Joint torique	Junta de tipo O
7		5	Ref. 5	1	O-Ring	Joint torique	Junta de tipo O
8		5	Ref. 5	1	O-Ring	Joint torique	Junta de tipo O
9		2	Ref. 2	1	Body	Corps	Cuerpo
10		2	Ref. 2	1	Spool	Tiroir	Cajoncillo
11	6193780M91	2	Mech. Optd Z1	1	Kit, Parts	Lot de pièces	Juego de piezas
12		11	Ref. 11	1	Screw	Vis	Tornillo
13	6193783M91	11	Bellows	1	Kit, Parts	Lot de pièces	Juego de piezas
14		13	Ref. 13	1	Seal	Joint	Junta
15		13	Ref. 13	2	Screw	Vis	Tornillo
16		13	Ref. 13	1	Cover	Cache	Tapa
17		11	Ref. 11	1	Plate	Plaque	Placa
18	6194492M1	11	Lip	1	Seal	Joint	Junta
19	6193784M91	2	Mech Optd A2	1	Kit, Parts	Lot de pièces	Juego de piezas
20	6194492M1	21	Lip	1	Seal	Joint	Junta
21		21	Ref. 21	1	Plate	Plaque	Placa
22		21	Ref. 21	1	Holder	Porte-injecteur	Retén
23		21	Ref. 21	1	Spring	Ressort	Muelle
24		21	Ref. 21	1	Holder	Porte-injecteur	Retén
25		21	Ref. 21	1	Screw	Vis	Tornillo
26		21	Ref. 21	1	Cap	Chapeau	Sombbrero
27		21	Ref. 21	2	Bolt	Boulon	Perno
28		2	Ref. 2	X	Cover	Cache	Tapa
29	6193778M91	2		1	Valve, Press. Relief	Soupape de sécurité	Válvula de seguridad
30		29	Ref. 29	1	Nut	Écrou	Tuerca
31		29	Ref. 29	1	Valve	Soupape	Válvula
32	6193779M91	29	Ref. 29 Secondary Valves	1	Kit, Seal	Pochette de joints	Juego de juntas
33		32	Ref. 32	1	O-Ring	Joint torique	Junta de tipo O
34		32	Ref. 32	1	O-Ring	Joint torique	Junta de tipo O
35		32	Ref. 32	1	O-Ring	Joint torique	Junta de tipo O
36	6193774M91	2	Compensator	1	Valve Assy	Ensemble de soupape	Válvula, Conj.
37		36	Ref. 36	1	Plug	Bouchon	Tapón
38		36	Ref. 36	1	O-Ring	Joint torique	Junta de tipo O
39		36	Ref. 36	1	Valve	Soupape	Válvula
40		36	Ref. 36	1	Guide	Guide	Guía
41	6193775M91	2		2	Valve, Check	Clapet anti-retour	Válvula de parada
42		41	Ref. 41	1	Plug	Bouchon	Tapón
43		41	Ref. 41	1	O-Ring	Joint torique	Junta de tipo O



880
 TX760B TX860B
 TX870B

832 834 842 844 852 854

68009C07.1

6199042M3

1

Jan-06

Loader Controls
Commandes de Chargeur
Mandos de cargadora

Hydraulic Valve
Distributeur de Commande Hydraulique
Distribuidor de mando hidráulico

Bucket Section, 7 In-1
Élément de Godet 7-en-1
Elemento de cuchara 7 x 1

C-68009-07.1-A

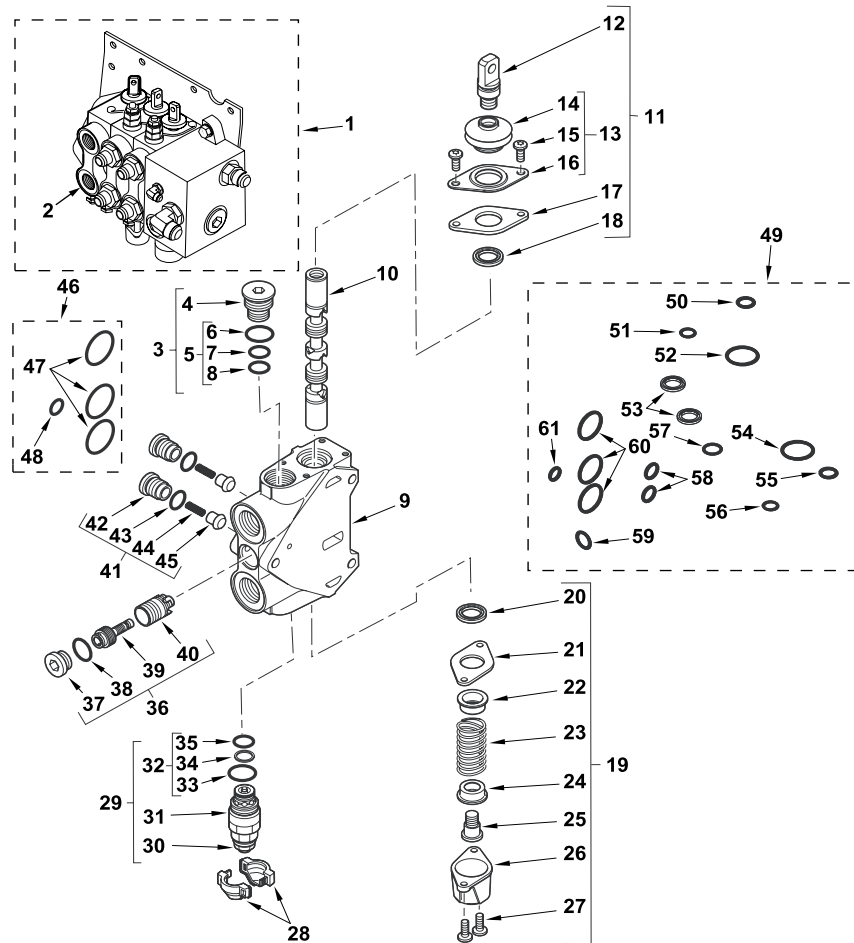

44		41	Ref. 41	1	Spring	Ressort	Muelle
45		41	Ref. 41	1	Valve	Soupape	Válvula
46	6193771M91		Interface	X	Kit, Seal	Pochette de joints	Juego de juntas
47		46	Ref. 46	3	O-Ring	Joint torique	Junta de tipo O
48		46	Ref. 46	1	O-Ring	Joint torique	Junta de tipo O
49	6193781M91			X	Kit, Seal	Pochette de joints	Juego de juntas
50		49	18.77 x 1.78 Ref. 49	1	O-Ring	Joint torique	Junta de tipo O
51		49	15.6 x 1.78 Ref. 49	1	O-Ring	Joint torique	Junta de tipo O
52		49	36.3 x 1.78 Ref. 49	1	O-Ring	Joint torique	Junta de tipo O
53	6194492M1	49	Lip	2	Seal	Joint	Junta
54		49	36.3 x 1.78 Ref. 49	1	O-Ring	Joint torique	Junta de tipo O
55		49	18.77 x 1.78 Ref. 49	1	O-Ring	Joint torique	Junta de tipo O
56		49	15.6 x 1.78 Ref. 49	1	O-Ring	Joint torique	Junta de tipo O
57		49	18 x 2.5 Ref. 49	1	O-Ring	Joint torique	Junta de tipo O
58		49	15 x 2 Ref. 49	2	O-Ring	Joint torique	Junta de tipo O
59		49	19.4 x 2.1 Ref. 49	1	O-Ring	Joint torique	Junta de tipo O
60		49	29.82 x 2.62 Ref. 49	3	O-Ring	Joint torique	Junta de tipo O
61		49	10.77 x 2.62 Ref. 49	1	O-Ring	Joint torique	Junta de tipo O

A Part number to be advised
 Référence pièce à demander
 Indicar número de pieza



880
 TX760B TX860B
 TX870B

832 834 842 844 852 854

68009C07.1

6199042M3

1

Jan-06

Loader Controls
Commandes de Chargeur
Mandos de cargadora

Hydraulic Valve
Distributeur de Commande Hydraulique
Distribuidor de mando hidráulico

Outlet
Deversoir
Salida

C-68009-08.1-A

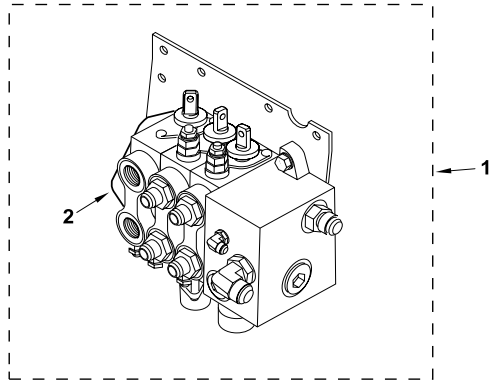

1	6109210M91	3 Spool	1	Valve Assy, Control	Ensemble distribution	Distribuidor, Conj.
2		1 (A)	1	Valve	Soupape	Válvula
3		2  Ref. 2	1	Cover	Cache	Tapa
4		2  Ref. 2	3	Rod Assy	Ensemble tringlerie	Tirantes, Conj.
5		4  Ref. 4	1	Rod	Tringle	Vástago
6		4  Ref. 4	1	Nut	Écrou	Tuerca
7	6193771M91	Interface	X	Kit, Seal	Pochette de joints	Juego de juntas
8		7  Ref. 7	3	O-Ring	Joint torique	Junta de tipo O
9		7  Ref. 7	1	O-Ring	Joint torique	Junta de tipo O

A Part number to be advised
Référence pièce à demander
Indicar número de pieza

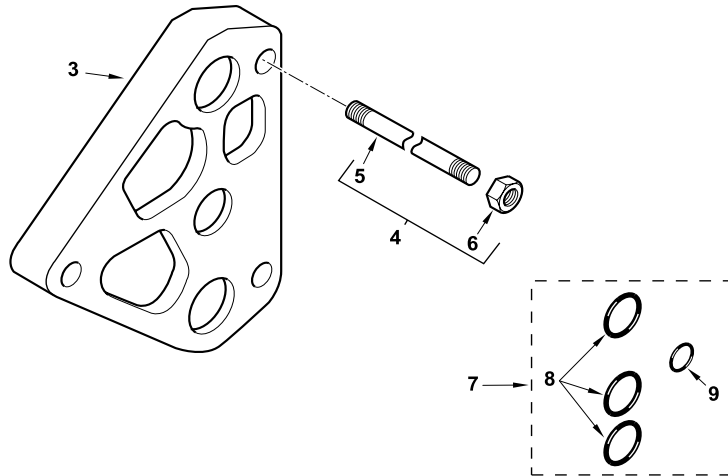

880
TX760B TX860B
TX870B

832 834 842 844 852 854

68009C08.1

6199042M3

1

Jan-06

Loader Controls
Commandes de Chargeur
Mandos de cargadora

Lower Control Levers
Partie Inférieure
Palancas de mando inferiores

7 in 1 Bucket
 Benne 7 en 1
 Benna 7 in 1

Servo
 Servo
 Servo

C-68008-02.1-A

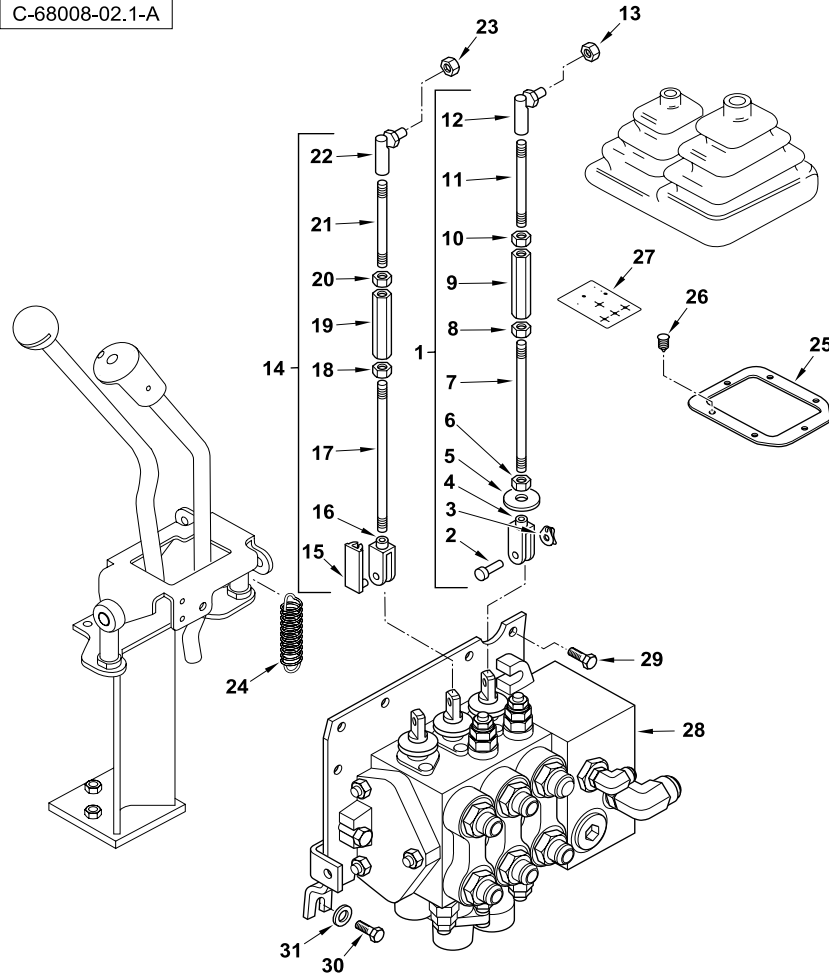

1	6102738M93		1	Rod Assy	Ensemble tringlerie	Tirantes, Conj.	
2	6102816M1	1	1	Pin, Clevis	Axe de chape	Eje de brida	
3	3516322M1	1	1	Clip	Clip	Clip	
4	3519590M1	1	LH Thread	1	Clevis	Chape	Brida
5	3518878M3	1		1	Washer	Rondelle	Arandela
6	3519650M1	1	M8 LH Thread	1	Nut	Écrou	Tuerca
7		1		1	Rod	Tringle	Vástago
8	339169X1	1	M8	1	Nut	Écrou	Tuerca
9	6102733M1	1		1	Turnbuckle	Tendeur de tringle	Torniquete
10	3519650M1	1	M8 LH Thread	1	Nut	Écrou	Tuerca
11		1		1	Rod	Tringle	Vástago
12	3519589M1	1		1	Ball Joint	Rotule	Rotula
13	394367X1		M8	1	Nut, Lock	Écrou de blocage	Tuerca de retención
14	6102737M92			2	Rod Assy	Ensemble tringlerie	Tirantes, Conj.
15	3520666M1	14		1	Pin, Clevis	Axe de chape	Eje de brida
16	3519590M1	14	LH Thread	1	Clevis	Chape	Brida
17		14	➡ Ref. 14	1	Rod	Tringle	Vástago
18	339169X1	14	M8	1	Nut	Écrou	Tuerca
19	6102733M1	14		1	Turnbuckle	Tendeur de tringle	Torniquete
20	3519650M1	14	M8 LH Thread	1	Nut	Écrou	Tuerca
21		14	➡ Ref. 14	1	Rod	Tringle	Vástago
22	3519589M1	14		1	Ball Joint	Rotule	Rotula
23	394367X1		M8	2	Nut, Lock	Écrou de blocage	Tuerca de retención
24	6109761M1			1	Spring	Ressort	Muelle
25	3516856M3			1	Plate	Plaque	Placa
26	3521303M3			6	Fastener	Attache	Enganche
27	6101874M1			1	Decal	Adhésif	Adhesivo
28	6109325M91		👁 [68008C01.1] 3 Spool 7:1	1	Valve Assy, Control	Ensemble distribution	Distribuidor, Conj.
29	3009492X1		M10 x 25	2	Screw	Vis	Tornillo
30	3009492X1		M10 x 25	1	Screw	Vis	Tornillo
31	385362X1		M10	1	Washer	Rondelle	Arandela



880
 TX760B TX860B
 TX870B

832 834 842 844 852 854

68008C02.1

6199042M3

1

Jan-06

Loader Controls
Commandes de Chargeur
Mandos de cargadora

Lower Control Levers
Partie Inférieure
Palancas de mando inferiores

Servo
 Servo
 Servo

C-68009-02.1-A

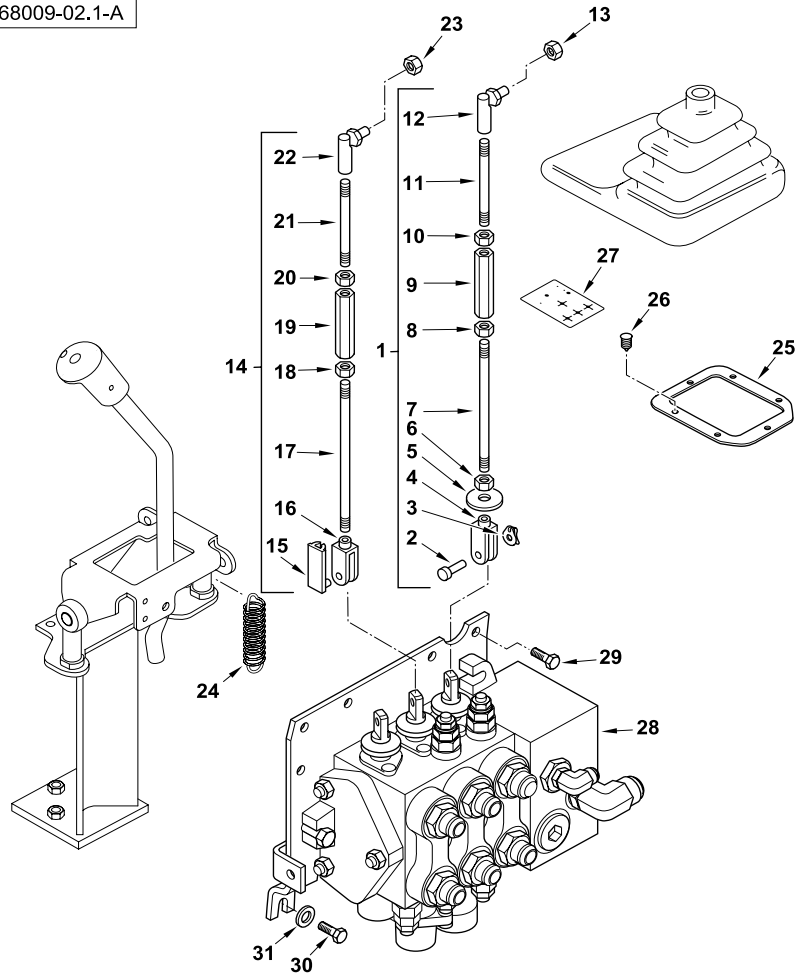

1	6102738M93			1	Rod Assy	Ensemble tringlerie	Tirantes, Conj.
2	6102816M1	1		1	Pin, Clevis	Axe de chape	Eje de brida
3	3516322M1	1		1	Clip	Clip	Clip
4	3519590M1	1	LH Thread	1	Clevis	Chape	Brida
5	3518878M3	1		1	Washer	Rondelle	Arandela
6	3519650M1	1	M8 LH Thread	1	Nut	Écrou	Tuerca
7		1		1	Rod	Tringle	Vástago
8	339169X1	1	M8	1	Nut	Écrou	Tuerca
9	6102733M1	1		1	Turnbuckle	Tendeur de tringle	Torniquete
10	3519650M1	1	M8 LH Thread	1	Nut	Écrou	Tuerca
11		1		1	Rod	Tringle	Vástago
12	3519589M1	1		1	Ball Joint	Rotule	Rotula
13	394367X1		M8	1	Nut, Lock	Écrou de blocage	Tuerca de retención
14	6102737M92			1	Rod Assy	Ensemble tringlerie	Tirantes, Conj.
15	3520666M1	14		1	Pin, Clevis	Axe de chape	Eje de brida
16	3519590M1	14	LH Thread	1	Clevis	Chape	Brida
17		14	➡ Ref. 14	1	Rod	Tringle	Vástago
18	339169X1	14	M8	1	Nut	Écrou	Tuerca
19	6102733M1	14		1	Turnbuckle	Tendeur de tringle	Torniquete
20	3519650M1	14	M8 LH Thread	1	Nut	Écrou	Tuerca
21		14	➡ Ref. 14	1	Rod	Tringle	Vástago
22	3519589M1	14		1	Ball Joint	Rotule	Rotula
23	394367X1		M8	1	Nut, Lock	Écrou de blocage	Tuerca de retención
24	6109761M1			1	Spring	Ressort	Muelle
25	3516856M3			1	Plate	Plaque	Placa
26	3521303M3			6	Fastener	Attache	Enganche
27	6101873M1			1	Decal	Adhésif	Adhesivo
28	6109325M91		👁 [68009C03.1 1] 3 Spool 7:1	1	Valve Assy, Control	Ensemble distribution	Distribuidor, Conj.
29	3009492X1	M10 x 25		2	Screw	Vis	Tornillo
30	3009492X1	M10 x 25		1	Screw	Vis	Tornillo
31	385362X1	M10		1	Washer	Rondelle	Arandela



880
 TX760B TX860B
 TX870B

832 834 842 844 852 854

68009C02.1

6199042M3

1

Jan-06

Loader Controls
Commandes de Chargeur
Mandos de cargadora

Upper Control Levers
Partie Supérieure
Palancas de mando superiores

7 in 1 Bucket
 Benne 7 en 1
 Benna 7 in 1

Servo
 Servo
 Servo

C-68008-01.1-A

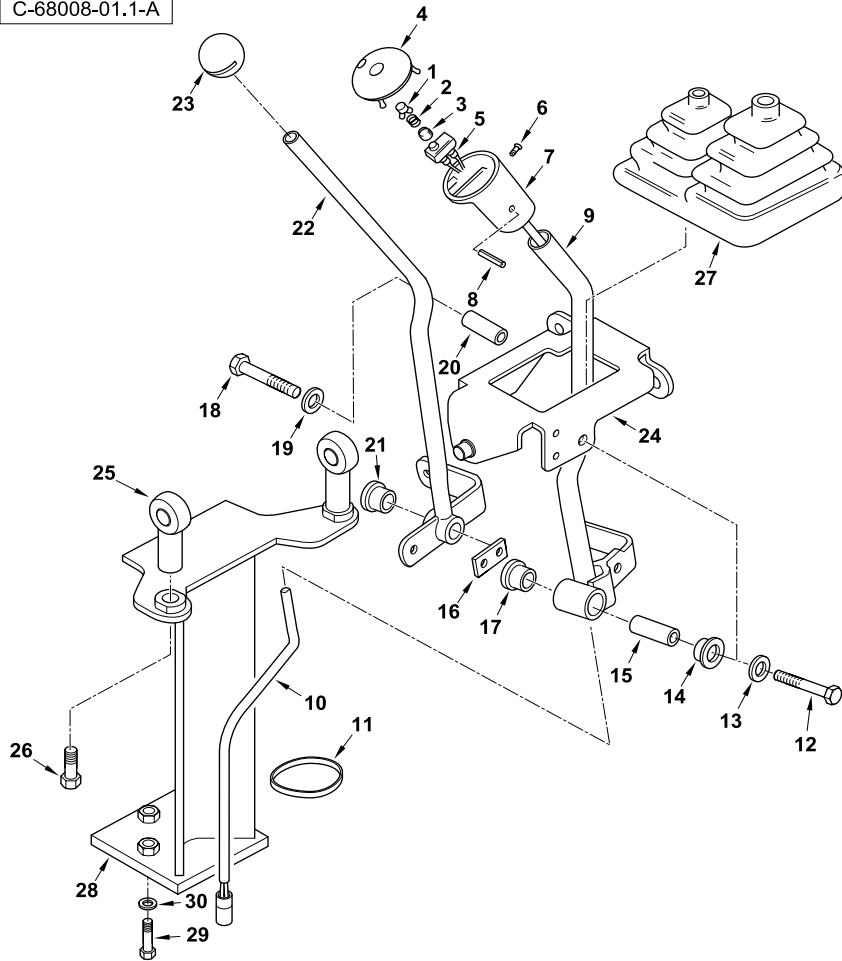

1	3521894M4		2	Button	Bouton	Botón
2	3520328M3		2	Spring	Ressort	Muelle
3	3522894M1		2	Boot	Soufflet	Fuelle
4	3522285M5		1	Knob	Boule	Bola
5	3522507M3		4	Pin	Axe	Pasador
6	3516886M1		2	Screw	Vis	Tornillo
7	3522621M5		1	Grip	Poignée de levier	Empuñ. Palanca
8	3019531X1		1	Pin, Roll	Goupille élastique	Pasador elástico
9	6109383M91		1	Lever Assy	Ensemble de levier	Palanca, Conj.
10	3516043M94		1	Harness	Faisceau	Haz
11	1664405M1		1	Tie, Cable	Attache câble	Enlace de Cable
12	339291X1	M8 x 55	1	Screw	Vis	Tornillo
13	6108769M1	M8	1	Washer, Lock	Rondelle de blocage	Arandela de freno
14	6106560M1		1	Bushing	Bague	Anillo
15	6106561M3		1	Spacer	Entretoise	Traviesa
16	6106562M1		1	Plate	Plaque	Placa
17	6106560M1		1	Bushing	Bague	Anillo
18	339291X1	M8 x 55	1	Screw	Vis	Tornillo
19	6108769M1	M8	1	Washer, Lock	Rondelle de blocage	Arandela de freno
20	6106561M3		1	Spacer	Entretoise	Traviesa
21	6106560M1		2	Bushing	Bague	Anillo
22	6109386M91		1	Lever Assy	Ensemble de levier	Palanca, Conj.
23	3509755M2		1	Knob	Boule	Bola
24	6109381M91		1	Cradle	Berceau	Soporte
25	6102844M1		2	Mount	Support de fixation	Soporte de fijación
26	3009505X1	M12 x 25	2	Bolt	Boulon	Perno
27	6109928M1		1	Boot	Soufflet	Fuelle
28	6109802M91		1	Support Assy	Ensemble de support	Apoyadero, Conj.
29	339009X1	M8 x 35	3	Screw	Vis	Tornillo
30	339374X1	M8	3	Washer, Lock	Rondelle de blocage	Arandela de freno



880
 TX760B TX860B
 TX870B

832 834 842 844 852 854

68008C01.1

6199042M3

1

Jan-06

Loader Controls
Commandes de Chargeur
Mandos de cargadora

Upper Control Levers
Partie Supérieure
Palancas de mando superiores

Servo
 Servo
 Servo

C-68009-01.1-A

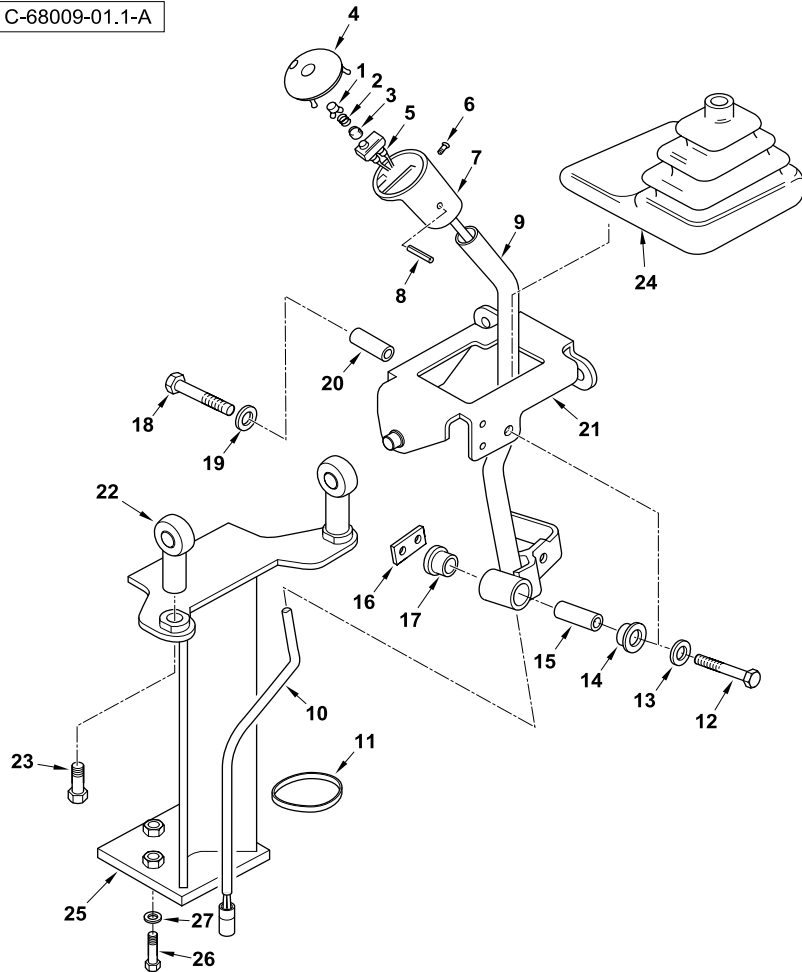

1	3521894M4		2	Button	Bouton	Botón
2	3520328M3		2	Spring	Ressort	Muelle
3	3522894M1		2	Boot	Soufflet	Fuelle
4	3522285M5		1	Knob	Boule	Bola
5	3522507M3		4	Pin	Axe	Pasador
6	3516886M1		2	Screw	Vis	Tornillo
7	3522621M5		1	Grip	Poignée de levier	Empuñ. Palanca
8	3019531X1		1	Pin, Roll	Goupille élastique	Pasador elástico
9	6109383M91		1	Lever Assy	Ensemble de levier	Palanca, Conj.
10	3516043M94		1	Harness	Faisceau	Haz
11	1664405M1		1	Tie, Cable	Attache câble	Enlace de Cable
12	339291X1	M8 x 55	1	Screw	Vis	Tornillo
13	6108769M1	M8	1	Washer, Lock	Rondelle de blocage	Arandela de freno
14	6106560M1		1	Bushing	Bague	Anillo
15	6106561M3		1	Spacer	Entretoise	Traviesa
16	6106562M1		1	Plate	Plaque	Placa
17	6106560M1		1	Bushing	Bague	Anillo
18	339291X1	M8 x 55	1	Screw	Vis	Tornillo
19	6108769M1	M8	1	Washer, Lock	Rondelle de blocage	Arandela de freno
20	6106561M3		1	Spacer	Entretoise	Traviesa
21	6109381M91		1	Cradle	Berceau	Soporte
22	6102844M1		2	Mount	Support de fixation	Soporte de fijación
23	3009505X1	M12 x 25	2	Bolt	Boulon	Perno
24	6109802M91		1	Support Assy	Ensemble de support	Apoyadero, Conj.
25	6109927M1		1	Boot	Soufflet	Fuelle
26	339009X1	M8 x 35	3	Screw	Vis	Tornillo
27	339374X1	M8	3	Washer, Lock	Rondelle de blocage	Arandela de freno



880
 TX760B TX860B
 TX870B

832 834 842 844 852 854

68009C01.1

6199042M3

1

Jan-06

Loader Hydraulics
Circuit Hydraulique de Chargeur
Circuito hidráulico cargadora

Bucket Cylinder
Vérin de Godet
Gato de cuchara

Standard Specification
 Qualité Inférieure
 Baja especificación

C-67001-03.1-B

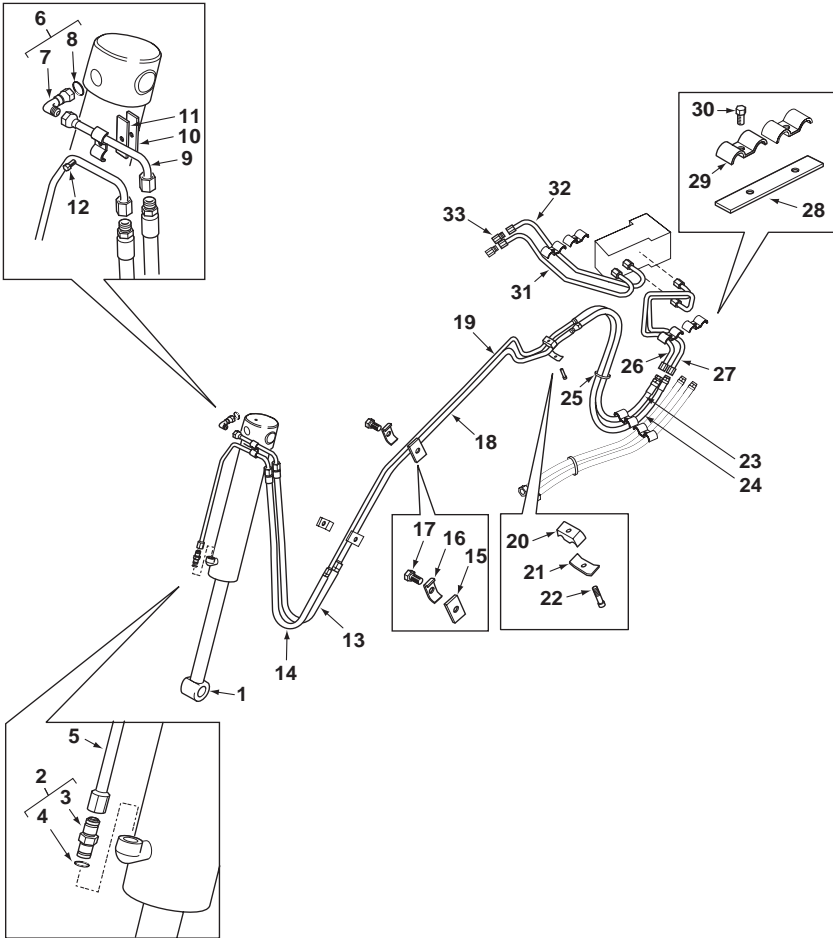

1	5000119M91	67001C04.1	1	Cylinder Assy	Ensemble de vérin	Gato, Conj.
2	835013M91		1	Connector Assy	Ensemble connexion	Conexión, Conj.
3		2	1	Union	Union	Unión
4	835024M1	2	1	O-Ring	Joint torique	Junta de tipo O
5	6109514M91		1	Tube Assy	Tuyauterie	Conjunto de tubería
6	835007M91		1	Elbow, 90°	Coude à 90°	Codo, 90°
7		6	1	Elbow	Coude	Codo
8	835024M1	6	1	O-Ring	Joint torique	Junta de tipo O
9	6109536M91		1	Tube Assy	Tuyauterie	Conjunto de tubería
10	6109526M91		1	Plate Assy	Ensemble de plaque	Placa, Conj.
11	6106109M1		1	Pad, Rubber	Plaque de caoutchouc	Placa, Caucho
12	339761X1	M8 x 25	1	Screw	Vis	Tornillo
13	6109530M91		1	Hose Assy	Ensemble de flexible	Flexible, Conj.
14	6109529M91		1	Hose Assy	Ensemble de flexible	Flexible, Conj.
15	6106109M1		2	Pad, Rubber	Plaque de caoutchouc	Placa, Caucho
16	6101228M1		2	Bracket, Clamp	Bride de fixation	Brida de fijación
17	339123X1	M8 x 20	2	Bolt	Boulon	Perno
18	6102461M91		1	Tube Assy	Tuyauterie	Conjunto de tubería
19	6102463M91		1	Tube Assy	Tuyauterie	Conjunto de tubería
20	3520528M2		1	Clamp	Collier de serrage	Argolla de cierre
21	3520534M1		1	Bracket, Clamp	Bride de fixation	Brida de fijación
22	339291X1	M8 x 55	1	Screw	Vis	Tornillo
23	6109793M91		1	Hose Assy	Ensemble de flexible	Flexible, Conj.
24	6109543M91		1	Hose Assy	Ensemble de flexible	Flexible, Conj.
25	1876229M1		1	Tie, Cable	Attache câble	Enlace de Cable
26	6109420M91		1	Tube Assy	Tuyauterie	Conjunto de tubería
27	6109422M91		1	Tube Assy	Tuyauterie	Conjunto de tubería
28	6101897M1		2	Pad, Rubber	Plaque de caoutchouc	Placa, Caucho
29	6101228M1		4	Bracket, Clamp	Bride de fixation	Brida de fijación
30	339124X1	M8 x 16	4	Screw	Vis	Tornillo
31	6109424M92		1	Tube Assy	Tuyauterie	Conjunto de tubería
32	6109426M92		1	Tube Assy	Tuyauterie	Conjunto de tubería
33	356447X1	7/8	2	Plug, Blank-Off	Obturbateur	Obturador



820
TX760B

801 802 803 804 805 806 807 808 831 832 833 834

67001C03.1

6199042M3

1

Jan-06

Loader Hydraulics
Circuit Hydraulique de Chargeur
Circuito hidráulico cargadora

Bucket Cylinder
Vérin de Godet
Gato de cuchara

Standard Specification
 Qualité Inférieure
 Baja especificación

Pacoma
 Pacoma
 Pacoma

C-67001-04.1-A

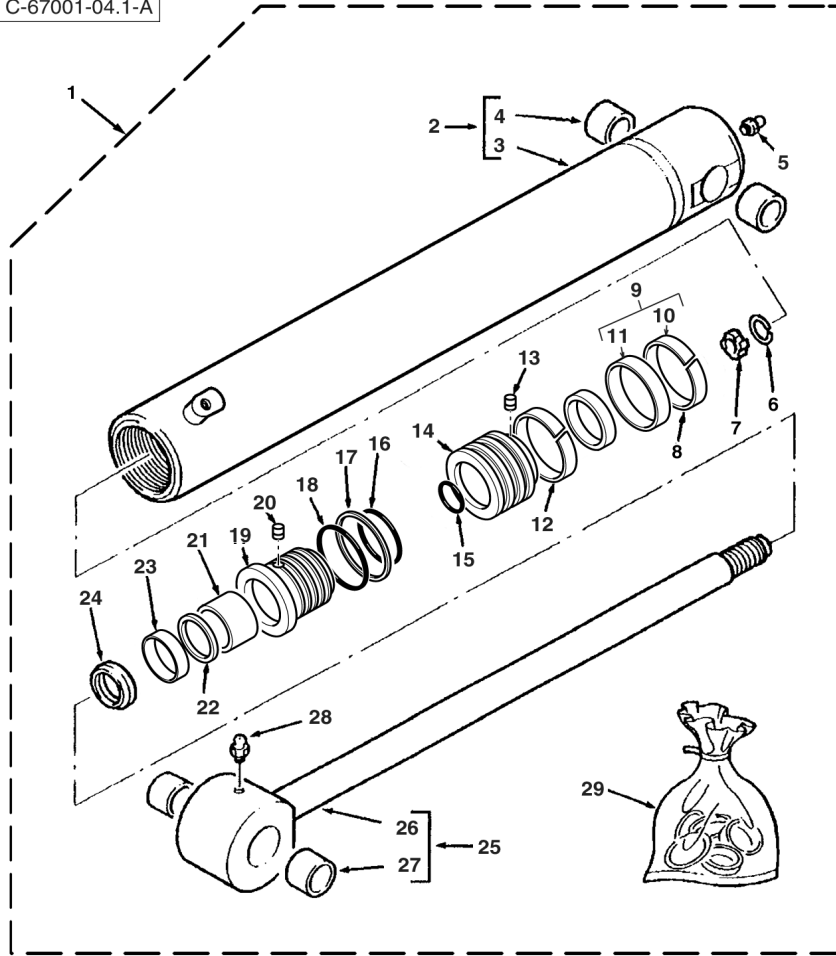

1	5000119M91		67001C03.1	1	Cylinder Assy	Ensemble de vérin	Gato, Conj.
2	5004071M91	1		1	Cylinder	Cylindre	Cilindro
3		2	Ref. 2	1	Tube, Cylinder	Cylindre de vérin	Cilindro de gato
4	3623390M1	2		2	Bush	Bague	Casquillo
5	339608X1	1		1	Fitting, Grease	Graisseur	Engrasador
6	3186587M1	1		1	Ring, Snap	Anneau d'arrêt	Anillo de resorte
7	3186586M1	1		1	Ring	Anneau	Aro
8	3484054M1	1 (A)		1	Ring	Anneau	Aro
9	3485214M91	1 (A)		1	Seal	Joint	Junta
10		9	Ref. 9	1	Seal	Joint	Junta
11		9	Ref. 9	1	Seal	Joint	Junta
12	3484054M1	1		1	Ring	Anneau	Aro
13	3402928M1	1		1	Screw	Vis	Tornillo
14	5004075M1	1		1	Piston	Piston	Pistón
15	359186X1	1 (A)		1	O-Ring	Joint torique	Junta de tipo O
16	359198X1	1 (A)		1	O-Ring	Joint torique	Junta de tipo O
17	378547X1	1 (A)		1	Ring	Anneau	Aro
18	3623670M1	1 (A)		1	O-Ring	Joint torique	Junta de tipo O
19	5004076M1	1		1	Bearing	Coussinet	Cojinete
20	3443386M1	1 (A)		1	Plug	Bouchon	Tapón
21	3484615M1	1 (A)		1	Ring	Anneau	Aro
22	3484055M1	1 (A)		1	Ring	Anneau	Aro
23	3485185M1	1 (A)		1	Seal	Joint	Junta
24	3487015M1	1 (A)		1	Ring	Anneau	Aro
25	3441631M91	1		1	Rod, Piston	Tige de vérin	Vástago cilindro
26		25	Ref. 25	1	Rod, Piston	Tige de vérin	Vástago cilindro
27	3623390M1	25		2	Bush	Bague	Casquillo
28	339608X1	1		1	Fitting, Grease	Graisseur	Engrasador
29	5004398M91		(B)	1	Kit, Parts	Lot de pièces	Juego de piezas

A Included in kit marked (B)
 Inclus dans jeu marqué (B)
 Incluido en juego marcado (B)

B Contains items marked (A)
 Comprend les pièces marquées (A)
 Incluye las piezas marcadas (A)



820
 TX760B

801 802 803 804 805 806 807 808 831 832 833 834

67001C04.1

6199042M3

1

Jan-06

Loader Hydraulics
Circuit Hydraulique de Chargeur
Circuito hidráulico cargadora

Bucket Cylinder
Vérin de Godet
Gato de cuchara

High Specification
Qualité Supérieure
Alta especificación

Not Illustrated
Non Illustrée
Nicht Abgebildet
Non Illustrato
No Ilustrado

1	5000120M91		 67002C04.1 1	1	Cylinder Assy	Ensemble de vérin	Gato, Conj.
2	835013M91			1	Connector Assy	Ensemble connexion	Conexión, Conj.
3		2	 Ref. 2	1	Union	Union	Unión
4	835024M1	2		1	O-Ring	Joint torique	Junta de tipo O
5	6109514M91			1	Tube Assy	Tuyauterie	Conjunto de tubería
6	835007M91			1	Elbow, 90°	Coude à 90°	Codo, 90°
7		6	 Ref. 6	1	Elbow	Coude	Codo
8	835024M1	6		1	O-Ring	Joint torique	Junta de tipo O
9	6109536M91			1	Tube Assy	Tuyauterie	Conjunto de tubería
10	6109526M91			1	Plate Assy	Ensemble de plaque	Placa, Conj.
11	6106109M1			1	Pad, Rubber	Plaque de caoutchouc	Placa, Caucho
12	339761X1		M8 x 25	1	Screw	Vis	Tornillo
13	6109530M91			1	Hose Assy	Ensemble de flexible	Flexible, Conj.
14	6109529M91			1	Hose Assy	Ensemble de flexible	Flexible, Conj.
15	6106109M1			2	Pad, Rubber	Plaque de caoutchouc	Placa, Caucho
16	6101228M1			2	Bracket, Clamp	Bride de fixation	Brida de fijación
17	339123X1		M8 x 20	2	Bolt	Boulon	Perno
18	6102461M91			1	Tube Assy	Tuyauterie	Conjunto de tubería
19	6102463M91			1	Tube Assy	Tuyauterie	Conjunto de tubería
20	3520528M2			1	Clamp	Collier de serrage	Argolla de cierre
21	3520534M1			1	Bracket, Clamp	Bride de fixation	Brida de fijación
22	339291X1		M8 x 55	1	Screw	Vis	Tornillo
23	6109793M91			1	Hose Assy	Ensemble de flexible	Flexible, Conj.
24	6109543M91			1	Hose Assy	Ensemble de flexible	Flexible, Conj.
25	1876229M1			1	Tie, Cable	Attache câble	Enlace de Cable
26	6109420M91			1	Tube Assy	Tuyauterie	Conjunto de tubería
27	6109422M91			1	Tube Assy	Tuyauterie	Conjunto de tubería
28	6101897M1			2	Pad, Rubber	Plaque de caoutchouc	Placa, Caucho
29	6101228M1			4	Bracket, Clamp	Bride de fixation	Brida de fijación
30	339124X1		M8 x 16	4	Screw	Vis	Tornillo
31	6109424M92			1	Tube Assy	Tuyauterie	Conjunto de tubería
32	6109426M92			1	Tube Assy	Tuyauterie	Conjunto de tubería
33	356447X1		7/8	2	Plug, Blank-Off	Obturbateur	Obturador



860 880 970 980
TX860B TX870B
TX970B

809 810 811 812 813 814 815 816 817 821 822 823 824 825 841 842 843 844 845
851 852 853 854 855 921 922 923 931 932

67002C03.1

6199042M3

1

Jan-06

Loader Hydraulics
Circuit Hydraulique de Chargeur
Circuito hidráulico cargadora

Bucket Cylinder
Vérin de Godet
Gato de cuchara

High Specification
 Qualité Supérieure
 Alta especificación

Pacoma
 Pacoma
 Pacoma

C-67002-04.1-A

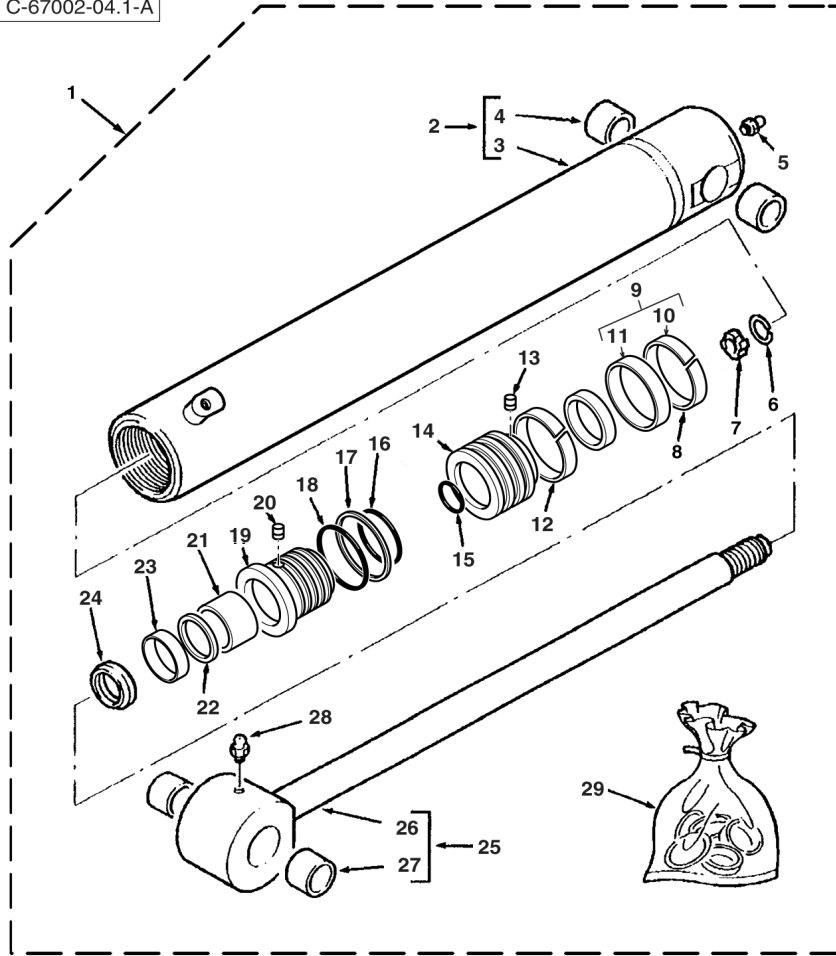

1	5000120M91	67002C03.1	1	Cylinder Assy	Ensemble de vérin	Gato, Conj.
2	5003936M91		1	Cylinder Assy	Ensemble de vérin	Gato, Conj.
3		Ref. 3	1	Tube, Cylinder	Cylindre de vérin	Cilindro de gato
4	3623390M1		2	Bush	Bague	Casquillo
5	339608X1		1	Fitting, Grease	Graisseur	Engrasador
6	3186587M1		1	Ring, Snap	Anneau d'arrêt	Anillo de resorte
7	3186586M1		1	Ring	Anneau	Aro
8	3442376M1	(A)	1	Ring	Anneau	Aro
9	3485249M91	(A)	1	Seal	Joint	Junta
10		Ref. 9	1	Seal	Joint	Junta
11		Ref. 9	1	Seal	Joint	Junta
12	3442376M1		1	Ring	Anneau	Aro
13	3402928M1		1	Screw	Vis	Tornillo
14	3485147M1		1	Piston	Piston	Pistón
15	359186X1	(A)	1	O-Ring	Joint torique	Junta de tipo O
16	359201X1	(A)	1	O-Ring	Joint torique	Junta de tipo O
17	1024334M1	(A)	1	Ring	Anneau	Aro
18	3487909M1	(A)	1	O-Ring	Joint torique	Junta de tipo O
19	5003941M1		1	Bearing	Coussinet	Cojinete
20	3443386M1	(A)	1	Plug	Bouchon	Tapón
21	3484615M1	(A)	1	Ring	Anneau	Aro
22	3484055M1	(A)	1	Ring	Anneau	Aro
23	3485185M1	(A)	1	Seal	Joint	Junta
24	3487015M1	(A)	1	Ring	Anneau	Aro
25	3441631M91		1	Rod, Piston	Tige de vérin	Vástago cilindro
26		Ref. 23	1	Rod, Piston	Tige de vérin	Vástago cilindro
27	3623390M1	23	2	Bush	Bague	Casquillo
28	339608X1		1	Fitting, Grease	Graisseur	Engrasador
29	3623397M91	(B)	1	Kit, Parts	Lot de pièces	Juego de piezas

A Included in kit marked (B)
 Inclus dans jeu marqué (B)
 Incluido en juego marcado (B)

B Contains items marked (A)
 Comprend les pièces marquées (A)
 Incluye las piezas marcadas (A)



860 880 970 980
 TX860B TX870B
 TX970B

809 810 811 812 813 814 815 816 817 821 822 823 824 825 841 842 843 844 845
 851 852 853 854 855 921 922 923 931 932

67002C04.1

6199042M3

1

Jan-06

Loader Hydraulics
Circuit Hydraulique de Chargeur
Circuito hidráulico cargadora

Bucket Cylinder
Vérin de Godet
Gato de cuchara

Standard Specification
 Qualité Inférieure
 Baja especificación

7 in 1 Bucket
 7 in 1 Bucket
 7 in 1 Bucket

C-67003-03.1-A

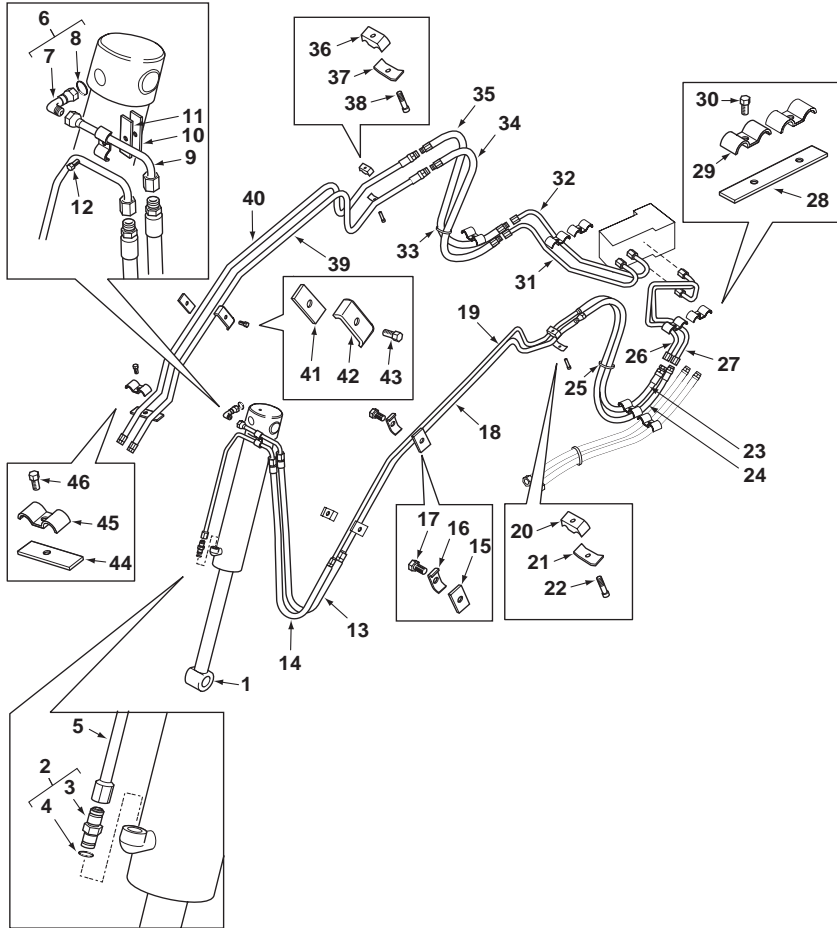

1	5000119M91	67003C04.1	1	Cylinder Assy	Ensemble de vérin	Gato, Conj.
2	835013M91		1	Connector Assy	Ensemble connexion	Conexión, Conj.
3		2	Ref. 2	Union	Union	Unión
4	835024M1	2		O-Ring	Joint torique	Junta de tipo O
5	6109514M91		1	Tube Assy	Tuyauterie	Conjunto de tubería
6	835007M91		1	Elbow, 90°	Coude à 90°	Codo, 90°
7		6	Ref. 6	Elbow	Coude	Codo
8	835024M1	6		O-Ring	Joint torique	Junta de tipo O
9	6109536M91		1	Tube Assy	Tuyauterie	Conjunto de tubería
10	6109526M91		1	Plate Assy	Ensemble de plaque	Placa, Conj.
11	6106109M1		1	Pad, Rubber	Plaque de caoutchouc	Placa, Caucho
12	339761X1	M8 x 25	1	Screw	Vis	Tornillo
13	6109530M91		1	Hose Assy	Ensemble de flexible	Flexible, Conj.
14	6109529M91		1	Hose Assy	Ensemble de flexible	Flexible, Conj.
15	6106109M1		2	Pad, Rubber	Plaque de caoutchouc	Placa, Caucho
16	6101228M1		2	Bracket, Clamp	Bride de fixation	Brida de fijación
17	339123X1	M8 x 20	2	Bolt	Boulon	Perno
18	6102461M91		1	Tube Assy	Tuyauterie	Conjunto de tubería
19	6102463M91		1	Tube Assy	Tuyauterie	Conjunto de tubería
20	3520528M2		1	Clamp	Collier de serrage	Argolla de cierre
21	3520534M1		1	Bracket, Clamp	Bride de fixation	Brida de fijación
22	339291X1	M8 x 55	1	Screw	Vis	Tornillo
23	6109793M91		1	Hose Assy	Ensemble de flexible	Flexible, Conj.
24	6109543M91		1	Hose Assy	Ensemble de flexible	Flexible, Conj.
25	1876229M1		1	Tie, Cable	Attache câble	Enlace de Cable
26	6109420M91		1	Tube Assy	Tuyauterie	Conjunto de tubería
27	6109422M91		1	Tube Assy	Tuyauterie	Conjunto de tubería
28	6101897M1		1	Pad, Rubber	Plaque de caoutchouc	Placa, Caucho
29	6101228M1		2	Bracket, Clamp	Bride de fixation	Brida de fijación
30	339124X1	M8 x 16	2	Screw	Vis	Tornillo
31	6109424M92		1	Tube Assy	Tuyauterie	Conjunto de tubería
32	6109426M92		1	Tube Assy	Tuyauterie	Conjunto de tubería
33	1876229M1		1	Tie, Cable	Attache câble	Enlace de Cable
34	6109804M91		1	Hose Assy	Ensemble de flexible	Flexible, Conj.
35	6109920M91		1	Hose Assy	Ensemble de flexible	Flexible, Conj.
36	3520538M2		1	Clamp	Collier de serrage	Argolla de cierre
37	3520534M1		1	Bracket, Clamp	Bride de fixation	Brida de fijación
38	339291X1	M8 x 55	1	Screw	Vis	Tornillo
39	6101236M91		1	Tube Assy	Tuyauterie	Conjunto de tubería
40	6101234M91		1	Tube Assy	Tuyauterie	Conjunto de tubería
41	6106109M1		1	Pad, Rubber	Plaque de caoutchouc	Placa, Caucho
42	6101228M1		1	Bracket, Clamp	Bride de fixation	Brida de fijación
43	339123X1	M8 x 20	1	Bolt	Boulon	Perno
44	6106109M1		1	Pad, Rubber	Plaque de caoutchouc	Placa, Caucho



820 880
 TX760B TX860B
 TX870B

801 802 803 804 805 806 807 808 831 832 833 834 842 844 852 854

67003C03.1

6199042M3

1

Jan-06

Loader Hydraulics
Circuit Hydraulique de Chargeur
Circuito hidráulico cargadora

Bucket Cylinder
Vérin de Godet
Gato de cuchara

Standard Specification
 Qualité Inférieure
 Baja especificación

7 in 1 Bucket
 7 in 1 Bucket
 7 in 1 Bucket

C-67003-03.1-A

45	6101228M1		1	Bracket, Clamp	Bride de fixation	Brida de fijación
46	339009X1	M8 x 35	1	Screw	Vis	Tornillo

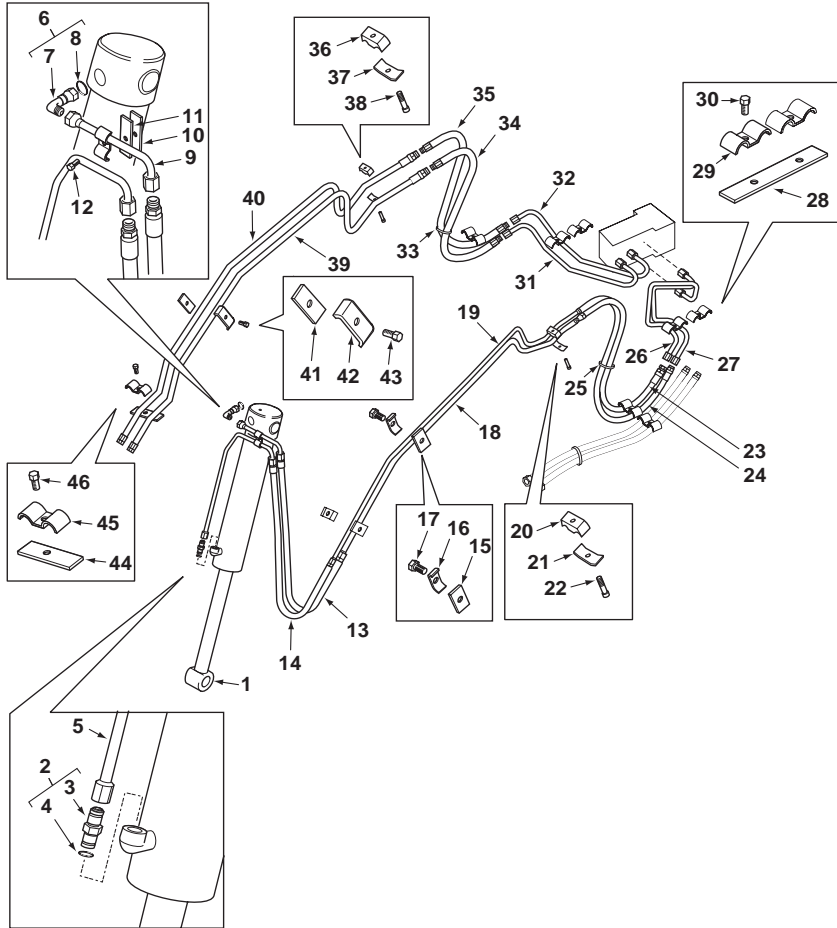

820 880
 TX760B TX860B
 TX870B

801 802 803 804 805 806 807 808 831 832 833 834 842 844 852 854

Loader Hydraulics
Circuit Hydraulique de Chargeur
Circuito hidráulico cargadora

Bucket Cylinder
Vérin de Godet
Gato de cuchara

Standard Specification
 Qualité Inférieure
 Baja especificación

Pacoma
 Pacoma
 Pacoma

C-67003-04.1-A

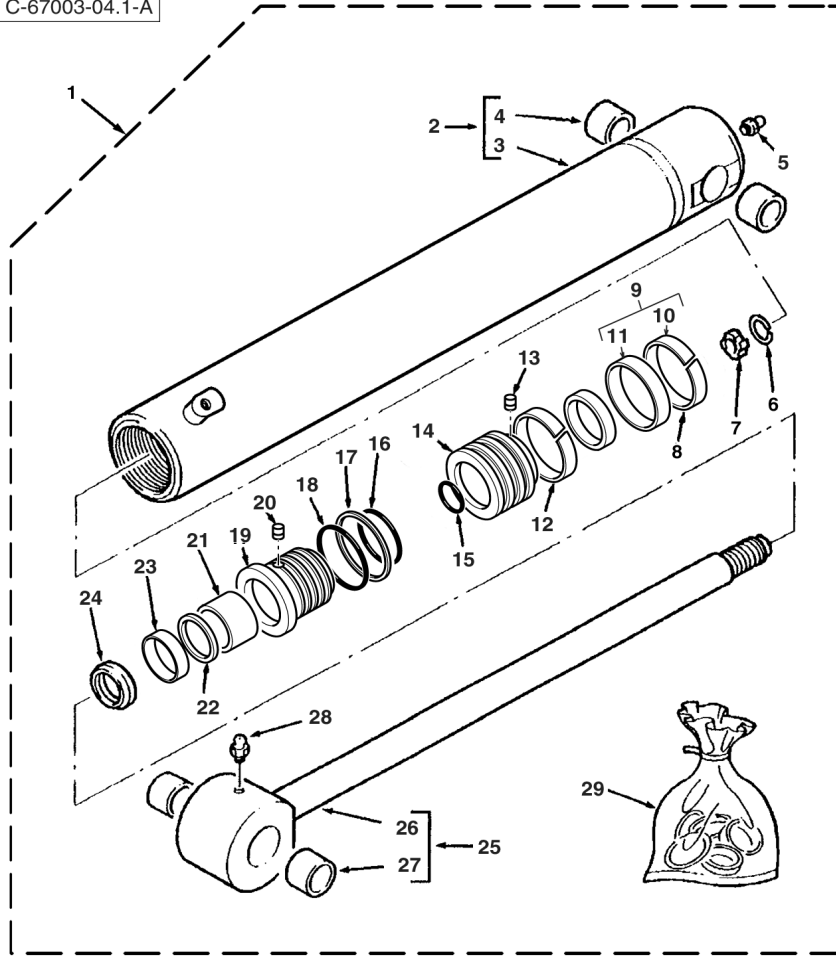

1	5000119M91		67003C03.1	1	Cylinder Assy	Ensemble de vérin	Gato, Conj.
2	5004071M91	1		1	Cylinder	Cylindre	Cilindro
3		2	Ref. 2	1	Tube, Cylinder	Cylindre de vérin	Cilindro de gato
4	3623390M1	2		2	Bush	Bague	Casquillo
5	339608X1	1		1	Fitting, Grease	Graisseur	Engrasador
6	3186587M1	1		1	Ring, Snap	Anneau d'arrêt	Anillo de resorte
7	3186586M1	1		1	Ring	Anneau	Aro
8	3484054M1	1 (A)		1	Ring	Anneau	Aro
9	3485214M91	1 (A)		1	Seal	Joint	Junta
10		9	Ref. 9	1	Seal	Joint	Junta
11		9	Ref. 9	1	Seal	Joint	Junta
12	3484054M1	1		1	Ring	Anneau	Aro
13	3402928M1	1		1	Screw	Vis	Tornillo
14	5004075M1	1		1	Piston	Piston	Pistón
15	359186X1	1 (A)		1	O-Ring	Joint torique	Junta de tipo O
16	359198X1	1 (A)		1	O-Ring	Joint torique	Junta de tipo O
17	378547X1	1 (A)		1	Ring	Anneau	Aro
18	3623670M1	1 (A)		1	O-Ring	Joint torique	Junta de tipo O
19	5004076M1	1		1	Bearing	Coussinet	Cojinete
20	3443386M1	1 (A)		1	Plug	Bouchon	Tapón
21	3484615M1	1 (A)		1	Ring	Anneau	Aro
22	3484055M1	1 (A)		1	Ring	Anneau	Aro
23	3485185M1	1 (A)		1	Seal	Joint	Junta
24	3487015M1	1 (A)		1	Ring	Anneau	Aro
25	3441631M91	1		1	Rod, Piston	Tige de vérin	Vástago cilindro
26		25	Ref. 25	1	Rod, Piston	Tige de vérin	Vástago cilindro
27	3623390M1	25		2	Bush	Bague	Casquillo
28	339608X1	1		1	Fitting, Grease	Graisseur	Engrasador
29	5004398M91		(B)	1	Kit, Parts	Lot de pièces	Juego de piezas

A Included in kit marked (B)
 Inclus dans jeu marqué (B)
 Incluido en juego marcado (B)

B Contains items marked (A)
 Comprend les pièces marquées (A)
 Incluye las piezas marcadas (A)



820 880
 TX760B TX860B
 TX870B

801 802 803 804 805 806 807 808 831 832 833 834 842 844 852 854

67003C04.1

6199042M3

1

Jan-06

Loader Hydraulics
Circuit Hydraulique de Chargeur
Circuito hidráulico cargadora

Bucket Cylinder
Vérin de Godet
Gato de cuchara

High Specification
 Qualité Supérieure
 Alta especificación

7 in 1 Bucket
 7 in 1 Bucket
 7 in 1 Bucket

C-67004-03.1-A

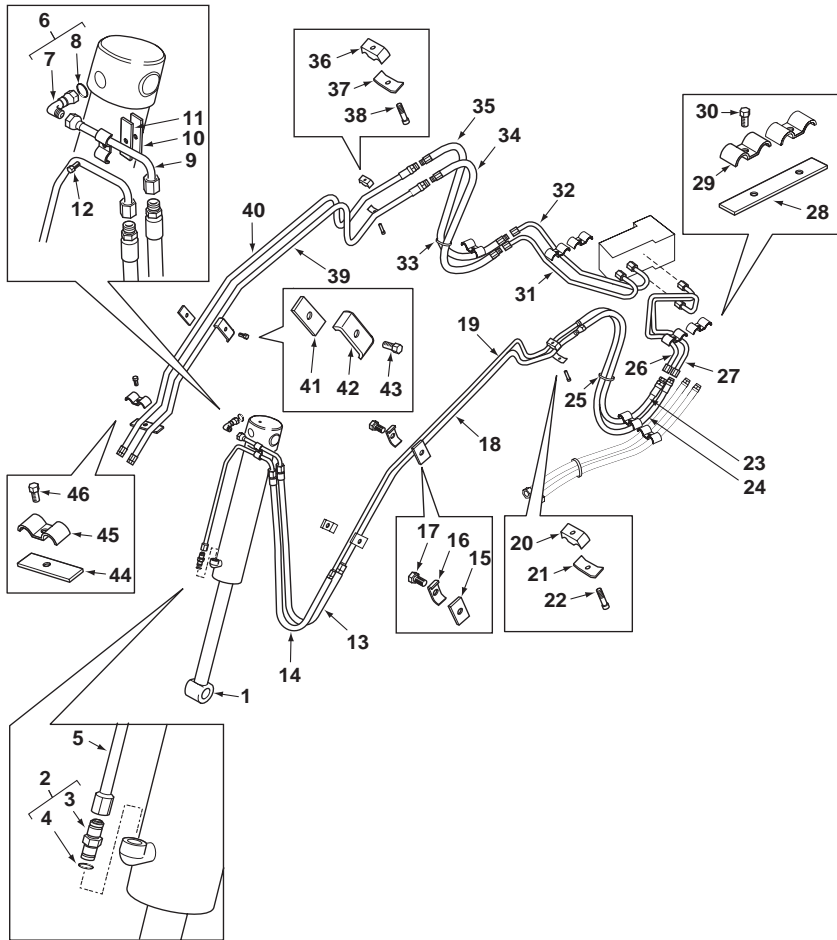

1	5000120M91	67004C04.1 1	1	Cylinder Assy	Ensemble de vérin	Gato, Conj.
2	835013M91		1	Connector Assy	Ensemble connexion	Conexión, Conj.
3		2 Ref. 2	1	Union	Union	Unión
4	835024M1	2	1	O-Ring	Joint torique	Junta de tipo O
5	6109514M91		1	Tube Assy	Tuyauterie	Conjunto de tubería
6	835007M91		1	Elbow, 90°	Coude à 90°	Codo, 90°
7		6 Ref. 6	1	Elbow	Coude	Codo
8	835024M1	6	1	O-Ring	Joint torique	Junta de tipo O
9	6109536M91		1	Tube Assy	Tuyauterie	Conjunto de tubería
10	6109526M91		1	Plate Assy	Ensemble de plaque	Placa, Conj.
11	6106109M1		1	Pad, Rubber	Plaque de caoutchouc	Placa, Caucho
12	339761X1	M8 x 25	1	Screw	Vis	Tornillo
13	6109530M91		1	Hose Assy	Ensemble de flexible	Flexible, Conj.
14	6109529M91		1	Hose Assy	Ensemble de flexible	Flexible, Conj.
15	6106109M1		2	Pad, Rubber	Plaque de caoutchouc	Placa, Caucho
16	6101228M1		2	Bracket, Clamp	Bride de fixation	Brida de fijación
17	339123X1	M8 x 20	2	Bolt	Boulon	Perno
18	6102461M91		1	Tube Assy	Tuyauterie	Conjunto de tubería
19	6102463M91		1	Tube Assy	Tuyauterie	Conjunto de tubería
20	3520528M2		1	Clamp	Collier de serrage	Argolla de cierre
21	3520534M1		1	Bracket, Clamp	Bride de fixation	Brida de fijación
22	339291X1	M8 x 55	1	Screw	Vis	Tornillo
23	6109793M91		1	Hose Assy	Ensemble de flexible	Flexible, Conj.
24	6109543M91		1	Hose Assy	Ensemble de flexible	Flexible, Conj.
25	1876229M1		1	Tie, Cable	Attache câble	Enlace de Cable
26	6109420M91		1	Tube Assy	Tuyauterie	Conjunto de tubería
27	6109422M91		1	Tube Assy	Tuyauterie	Conjunto de tubería
28	6101897M1		1	Pad, Rubber	Plaque de caoutchouc	Placa, Caucho
29	6101228M1		2	Bracket, Clamp	Bride de fixation	Brida de fijación
30	339124X1	M8 x 16	2	Screw	Vis	Tornillo
31	6109424M92		1	Tube Assy	Tuyauterie	Conjunto de tubería
32	6109426M92		1	Tube Assy	Tuyauterie	Conjunto de tubería
33	1876229M1		1	Tie, Cable	Attache câble	Enlace de Cable
34	6109804M91		1	Hose Assy	Ensemble de flexible	Flexible, Conj.
35	6109920M91		1	Hose Assy	Ensemble de flexible	Flexible, Conj.
36	3520538M2		1	Clamp	Collier de serrage	Argolla de cierre
37	3520534M1		1	Bracket, Clamp	Bride de fixation	Brida de fijación
38	339291X1	M8 x 55	1	Screw	Vis	Tornillo
39	6101236M91		1	Tube Assy	Tuyauterie	Conjunto de tubería
40	6101234M91		1	Tube Assy	Tuyauterie	Conjunto de tubería
41	6106109M1		1	Pad, Rubber	Plaque de caoutchouc	Placa, Caucho
42	6101228M1		1	Bracket, Clamp	Bride de fixation	Brida de fijación
43	339123X1	M8 x 20	1	Bolt	Boulon	Perno
44	6106109M1		1	Pad, Rubber	Plaque de caoutchouc	Placa, Caucho



860 880 970 980
 TX860B TX870B
 TX970B

809 810 811 812 813 814 815 816 817 821 822 823 824 825 841 842 843 844 845
 851 852 853 854 855 921 922 923 931 932

67004C03.1

6199042M3

1

Jan-06

Loader Hydraulics
Circuit Hydraulique de Chargeur
Circuito hidráulico cargadora

Bucket Cylinder
Vérin de Godet
Gato de cuchara

High Specification
 Qualité Supérieure
 Alta especificación

7 in 1 Bucket
 7 in 1 Bucket
 7 in 1 Bucket

C-67004-03.1-A

45	6101228M1		1	Bracket, Clamp	Bride de fixation	Brida de fijación
46	339009X1	M8 x 35	1	Screw	Vis	Tornillo

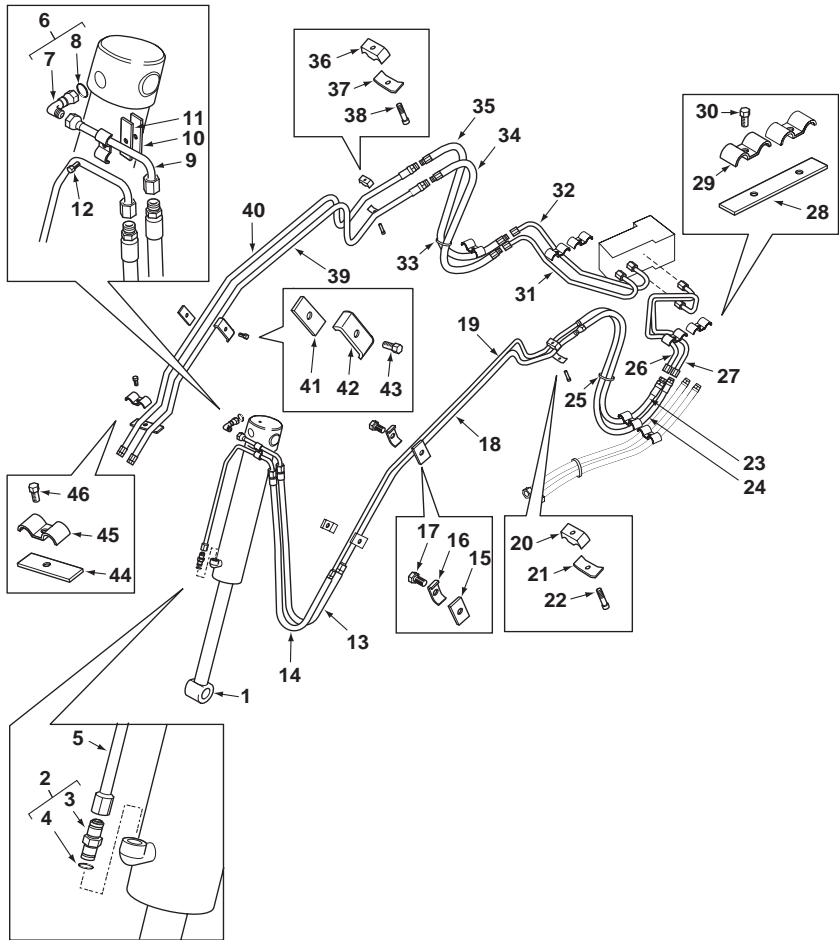

860 880 970 980
 TX860B TX870B
 TX970B

809 810 811 812 813 814 815 816 817 821 822 823 824 825 841 842 843 844 845
 851 852 853 854 855 921 922 923 931 932

Loader Hydraulics
Circuit Hydraulique de Chargeur
Circuito hidráulico cargadora

Bucket Cylinder
Vérin de Godet
Gato de cuchara

High Specification
 Qualité Supérieure
 Alta especificación

Pacoma
 Pacoma
 Pacoma

C-67004-04.1-A

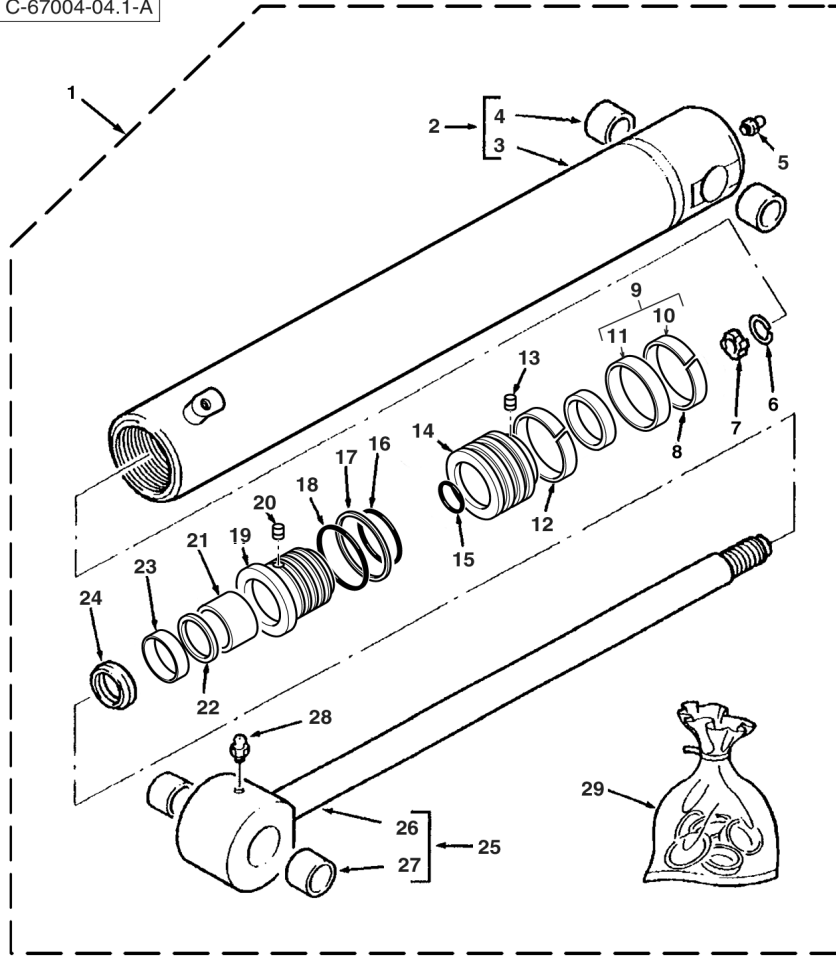

1	5000120M91	1	67004C03.1 1	1	Cylinder Assy	Ensemble de vérin	Gato, Conj.
2	5003936M91	1		1	Cylinder Assy	Ensemble de vérin	Gato, Conj.
3		3	Ref. 3	1	Tube, Cylinder	Cylindre de vérin	Cilindro de gato
4	3623390M1	3		2	Bush	Bague	Casquillo
5	339608X1	1		1	Fitting, Grease	Graisseur	Engrasador
6	3186587M1	1		1	Ring, Snap	Anneau d'arrêt	Anillo de resorte
7	3186586M1	1		1	Ring	Anneau	Aro
8	3442376M1	1 (A)		1	Ring	Anneau	Aro
9	3485249M91	1 (A)		1	Seal	Joint	Junta
10		9	Ref. 9	1	Seal	Joint	Junta
11		9	Ref. 9	1	Seal	Joint	Junta
12	3442376M1	1		1	Ring	Anneau	Aro
13	3402928M1	1		1	Screw	Vis	Tornillo
14	3485147M1	1		1	Piston	Piston	Pistón
15	359186X1	1 (A)		1	O-Ring	Joint torique	Junta de tipo O
16	359201X1	1 (A)		1	O-Ring	Joint torique	Junta de tipo O
17	1024334M1	1 (A)		1	Ring	Anneau	Aro
18	3487909M1	1 (A)		1	O-Ring	Joint torique	Junta de tipo O
19	5003941M1	1		1	Bearing	Coussinet	Cojinete
20	3443386M1	1 (A)		1	Plug	Bouchon	Tapón
21	3484615M1	1 (A)		1	Ring	Anneau	Aro
22	3484055M1	1 (A)		1	Ring	Anneau	Aro
23	3485185M1	1 (A)		1	Seal	Joint	Junta
24	3487015M1	1 (A)		1	Ring	Anneau	Aro
25	3441631M91	1		1	Rod, Piston	Tige de vérin	Vástago cilindro
26		23	Ref. 23	1	Rod, Piston	Tige de vérin	Vástago cilindro
27	3623390M1	23		2	Bush	Bague	Casquillo
28	339608X1	1		1	Fitting, Grease	Graisseur	Engrasador
29	3623397M91		(B)	1	Kit, Parts	Lot de pièces	Juego de piezas

A Included in kit marked (B)
 Inclus dans jeu marqué (B)
 Incluido en juego marcado (B)

B Contains items marked (A)
 Comprend les pièces marquées (A)
 Incluye las piezas marcadas (A)



860 880 970 980
 TX860B TX870B
 TX970B

809 810 811 812 813 814 815 816 817 821 822 823 824 825 841 842 843 844 845
 851 852 853 854 855 921 922 923 931 932

67004C04.1

6199042M3

1

Jan-06

Loader Hydraulics
Circuit Hydraulique de Chargeur
Circuito hidráulico cargadora

Bucket Cylinder
Vérin de Godet
Gato de cuchara

Standard Specification
 Qualité Inférieure
 Baja especificación

C-67005-03.1-B

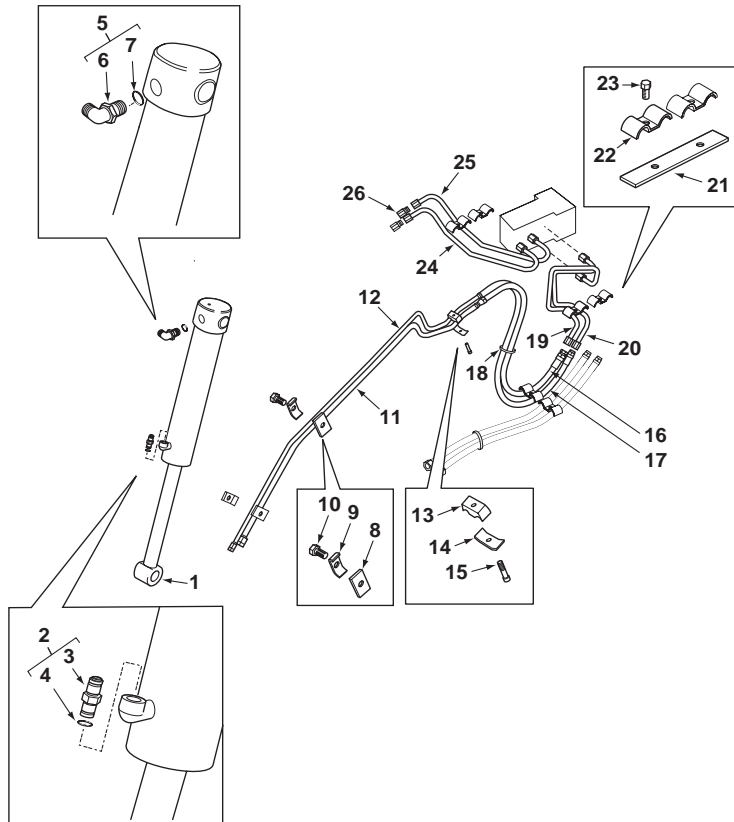

1	5000119M91	67005C04.1	1	Cylinder Assy	Ensemble de vérin	Gato, Conj.
2	835013M91		1	Connector Assy	Ensemble connexion	Conexión, Conj.
3		2	1	Union	Union	Unión
4	835024M1	2	1	O-Ring	Joint torique	Junta de tipo O
5	835007M91		1	Elbow, 90°	Coude à 90°	Codo, 90°
6		5	1	Elbow	Coude	Codo
7	835024M1	5	1	O-Ring	Joint torique	Junta de tipo O
8	6106109M1		2	Pad, Rubber	Plaque de caoutchouc	Placa, Caucho
9	6101228M1		2	Bracket, Clamp	Bride de fixation	Brida de fijación
10	339123X1	M8 x 20	2	Bolt	Boulon	Perno
11	6102461M91		1	Tube Assy	Tuyauterie	Conjunto de tubería
12	6102463M91		1	Tube Assy	Tuyauterie	Conjunto de tubería
13	3520528M2		1	Clamp	Collier de serrage	Argolla de cierre
14	3520534M1		1	Bracket, Clamp	Bride de fixation	Brida de fijación
15	339291X1	M8 x 55	1	Screw	Vis	Tornillo
16	6109793M91		1	Hose Assy	Ensemble de flexible	Flexible, Conj.
17	6109543M91		1	Hose Assy	Ensemble de flexible	Flexible, Conj.
18	1876229M1		1	Tie, Cable	Attache câble	Enlace de Cable
19	6109420M91		1	Tube Assy	Tuyauterie	Conjunto de tubería
20	6109422M91		1	Tube Assy	Tuyauterie	Conjunto de tubería
21	6101897M1		2	Pad, Rubber	Plaque de caoutchouc	Placa, Caucho
22	6101228M1		4	Bracket, Clamp	Bride de fixation	Brida de fijación
23	339124X1	M8 x 16	4	Screw	Vis	Tornillo
24	6109424M92		1	Tube Assy	Tuyauterie	Conjunto de tubería
25	6109426M92		1	Tube Assy	Tuyauterie	Conjunto de tubería
26	356447X1	7/8	2	Plug, Blank-Off	Obturateur	Obturador



820
TX760B

801 802 803 804 805 806 807 808 831 832 833 834

67005C03.1

6199042M3

1

Jan-06

Loader Hydraulics
Circuit Hydraulique de Chargeur
Circuito hidráulico cargadora

Bucket Cylinder
Vérin de Godet
Gato de cuchara

Standard Specification
 Qualité Inférieure
 Baja especificación

Pacoma
 Pacoma
 Pacoma

C-67005-04.1-A

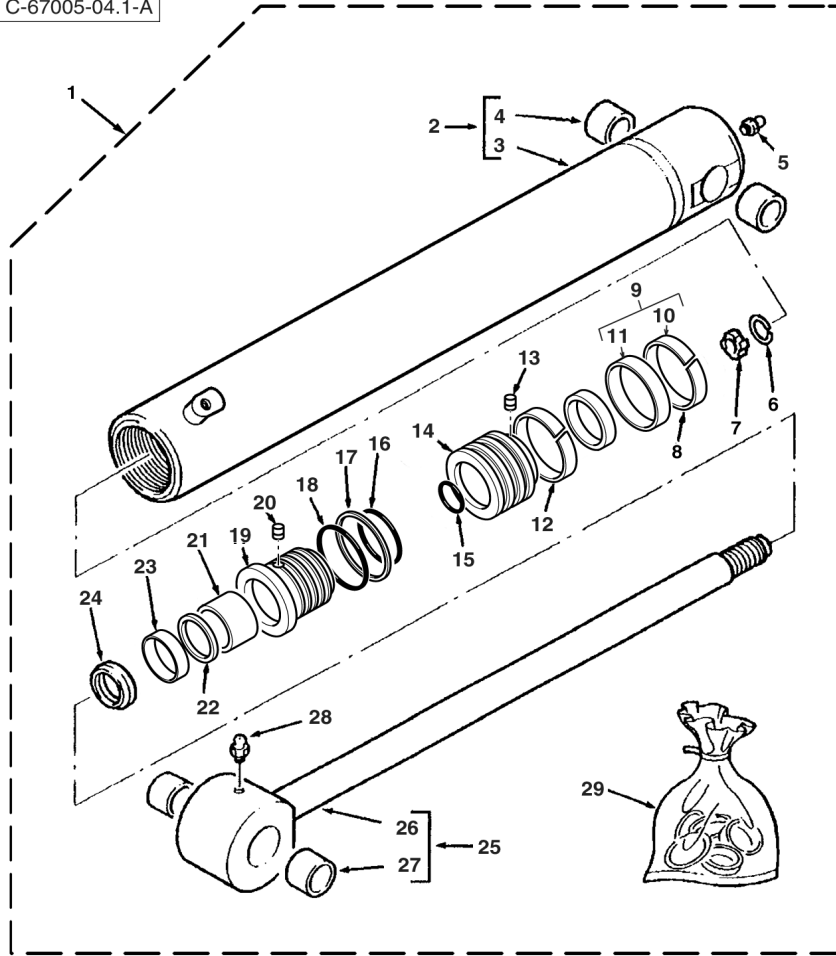

1	5000119M91		67005C03.1	1	Cylinder Assy	Ensemble de vérin	Gato, Conj.
2	5004071M91	1		1	Cylinder	Cylindre	Cilindro
3		2	Ref. 2	1	Tube, Cylinder	Cylindre de vérin	Cilindro de gato
4	3623390M1	2		2	Bush	Bague	Casquillo
5	339608X1	1		1	Fitting, Grease	Graisseur	Engrasador
6	3186587M1	1		1	Ring, Snap	Anneau d'arrêt	Anillo de resorte
7	3186586M1	1		1	Ring	Anneau	Aro
8	3484054M1	1 (A)		1	Ring	Anneau	Aro
9	3485214M91	1 (A)		1	Seal	Joint	Junta
10		9	Ref. 9	1	Seal	Joint	Junta
11		9	Ref. 9	1	Seal	Joint	Junta
12	3484054M1	1		1	Ring	Anneau	Aro
13	3402928M1	1		1	Screw	Vis	Tornillo
14	5004075M1	1		1	Piston	Piston	Pistón
15	359186X1	1 (A)		1	O-Ring	Joint torique	Junta de tipo O
16	359198X1	1 (A)		1	O-Ring	Joint torique	Junta de tipo O
17	378547X1	1 (A)		1	Ring	Anneau	Aro
18	3623670M1	1 (A)		1	O-Ring	Joint torique	Junta de tipo O
19	5004076M1	1		1	Bearing	Coussinet	Cojinete
20	3443386M1	1 (A)		1	Plug	Bouchon	Tapón
21	3484615M1	1 (A)		1	Ring	Anneau	Aro
22	3484055M1	1 (A)		1	Ring	Anneau	Aro
23	3485185M1	1 (A)		1	Seal	Joint	Junta
24	3487015M1	1 (A)		1	Ring	Anneau	Aro
25	3441631M91	1		1	Rod, Piston	Tige de vérin	Vástago cilindro
26		25	Ref. 25	1	Rod, Piston	Tige de vérin	Vástago cilindro
27	3623390M1	25		2	Bush	Bague	Casquillo
28	339608X1	1		1	Fitting, Grease	Graisseur	Engrasador
29	5004398M91		(B)	1	Kit, Parts	Lot de pièces	Juego de piezas

A Included in kit marked (B)
 Inclus dans jeu marqué (B)
 Incluido en juego marcado (B)

B Contains items marked (A)
 Comprend les pièces marquées (A)
 Incluye las piezas marcadas (A)



820
 TX760B

801 802 803 804 805 806 807 808 831 832 833 834

67005C04.1

6199042M3

1

Jan-06

Loader Hydraulics
Circuit Hydraulique de Chargeur
Circuito hidráulico cargadora

Bucket Cylinder
Vérin de Godet
Gato de cuchara

Standard Specification
 Qualité Inférieure
 Baja especificación

C-67006-03.1-B

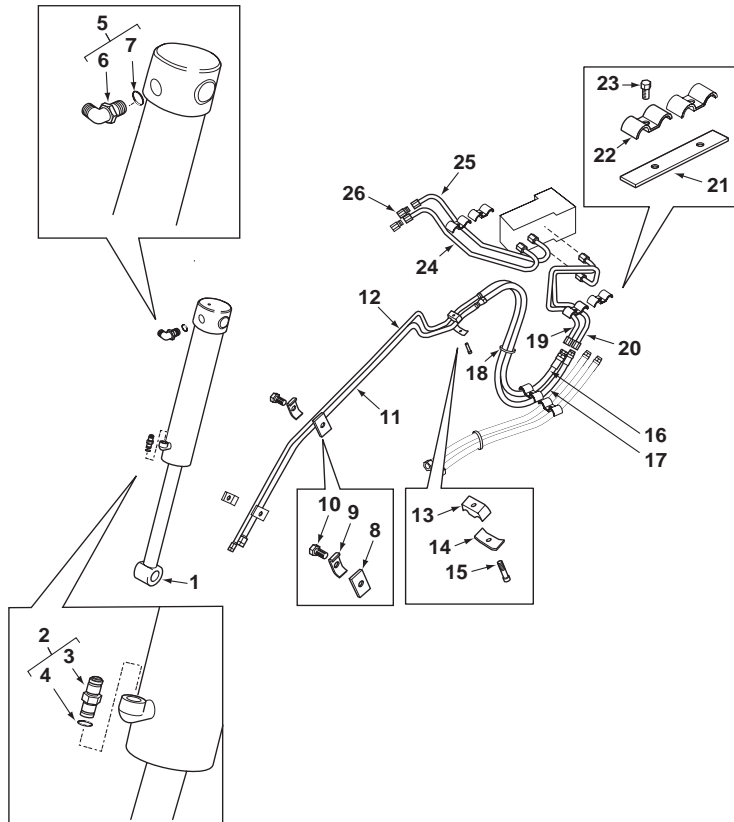

1	5000120M91	67006C04.1	1	Cylinder Assy	Ensemble de vérin	Gato, Conj.
2	835013M91		1	Connector Assy	Ensemble connexion	Conexión, Conj.
3		2	Ref. 2	Union	Union	Unión
4	835024M1	2		O-Ring	Joint torique	Junta de tipo O
5	835007M91		1	Elbow, 90°	Coude à 90°	Codo, 90°
6		5	Ref. 5	Elbow	Coude	Codo
7	835024M1	5		O-Ring	Joint torique	Junta de tipo O
8	6106109M1		2	Pad, Rubber	Plaque de caoutchouc	Placa, Caucho
9	6101228M1		2	Bracket, Clamp	Bride de fixation	Brida de fijación
10	339123X1	M8 x 20	2	Bolt	Boulon	Perno
11	6102461M91		1	Tube Assy	Tuyauterie	Conjunto de tubería
12	6102463M91		1	Tube Assy	Tuyauterie	Conjunto de tubería
13	3520528M2		1	Clamp	Collier de serrage	Argolla de cierre
14	3520534M1		1	Bracket, Clamp	Bride de fixation	Brida de fijación
15	339291X1	M8 x 55	1	Screw	Vis	Tornillo
16	6109793M91		1	Hose Assy	Ensemble de flexible	Flexible, Conj.
17	6109543M91		1	Hose Assy	Ensemble de flexible	Flexible, Conj.
18	1876229M1		1	Tie, Cable	Attache câble	Enlace de Cable
19	6109420M91		1	Tube Assy	Tuyauterie	Conjunto de tubería
20	6109422M91		1	Tube Assy	Tuyauterie	Conjunto de tubería
21	6101897M1		2	Pad, Rubber	Plaque de caoutchouc	Placa, Caucho
22	6101228M1		4	Bracket, Clamp	Bride de fixation	Brida de fijación
23	339124X1	M8 x 16	4	Screw	Vis	Tornillo
24	6109424M92		1	Tube Assy	Tuyauterie	Conjunto de tubería
25	6109426M92		1	Tube Assy	Tuyauterie	Conjunto de tubería
26	356447X1	7/8	2	Plug, Blank-Off	Obturateur	Obturador



860 880 970 980
 TX860B TX870B
 TX970B

813 814 815 816 817 821 822 823 824 825 841 842 843 844 845 851 852 853 854
 855 921 922 923 931 932

67006C03.1

6199042M3

1

Jan-06

Loader Hydraulics
Circuit Hydraulique de Chargeur
Circuito hidráulico cargadora

Bucket Cylinder
Vérin de Godet
Gato de cuchara

High Specification
 Qualité Supérieure
 Alta especificación

Pacoma
 Pacoma
 Pacoma

C-67006-04.1-A

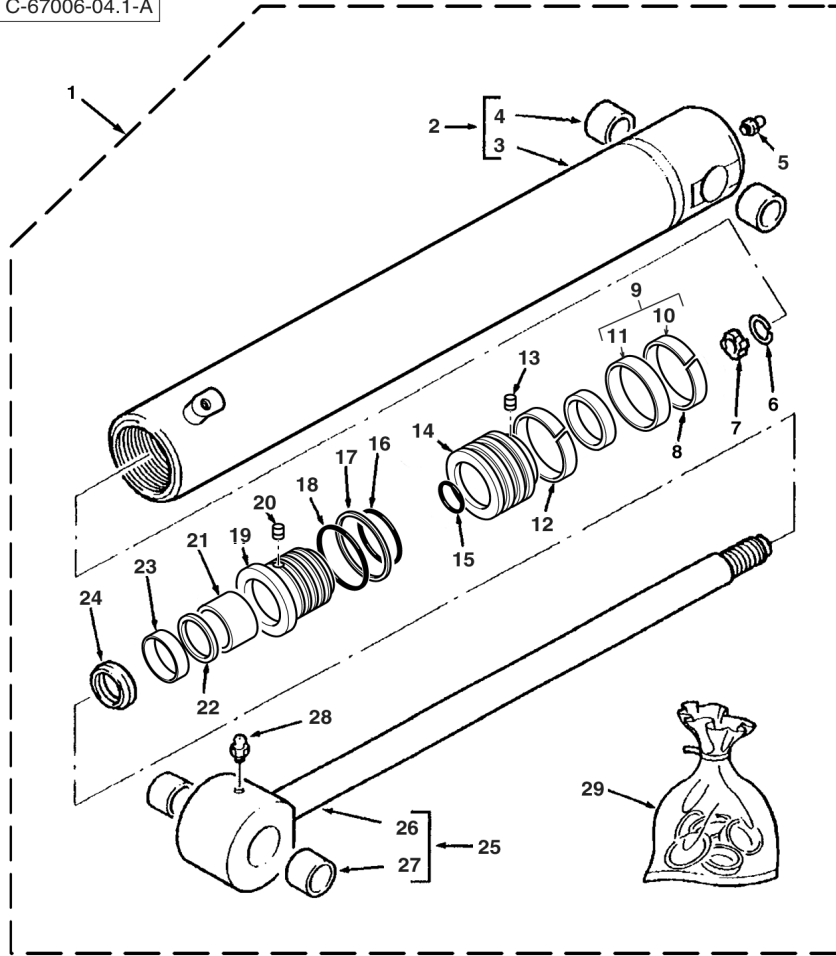

1	5000120M91		67006C03.1 1	1	Cylinder Assy	Ensemble de vérin	Gato, Conj.
2	5003936M91	1		1	Cylinder Assy	Ensemble de vérin	Gato, Conj.
3		3	Ref. 3	1	Tube, Cylinder	Cylindre de vérin	Cilindro de gato
4	3623390M1	3		2	Bush	Bague	Casquillo
5	339608X1	1		1	Fitting, Grease	Graisseur	Engrasador
6	3186587M1	1		1	Ring, Snap	Anneau d'arrêt	Anillo de resorte
7	3186586M1	1		1	Ring	Anneau	Aro
8	3442376M1	1 (A)		1	Ring	Anneau	Aro
9	3485249M91	1 (A)		1	Seal	Joint	Junta
10		9	Ref. 9	1	Seal	Joint	Junta
11		9	Ref. 9	1	Seal	Joint	Junta
12	3442376M1	1		1	Ring	Anneau	Aro
13	3402928M1	1		1	Screw	Vis	Tornillo
14	3485147M1	1		1	Piston	Piston	Pistón
15	359186X1	1 (A)		1	O-Ring	Joint torique	Junta de tipo O
16	359201X1	1 (A)		1	O-Ring	Joint torique	Junta de tipo O
17	1024334M1	1 (A)		1	Ring	Anneau	Aro
18	3487909M1	1 (A)		1	O-Ring	Joint torique	Junta de tipo O
19	5003941M1	1		1	Bearing	Coussinet	Cojinete
20	3443386M1	1 (A)		1	Plug	Bouchon	Tapón
21	3484615M1	1 (A)		1	Ring	Anneau	Aro
22	3484055M1	1 (A)		1	Ring	Anneau	Aro
23	3485185M1	1 (A)		1	Seal	Joint	Junta
24	3487015M1	1 (A)		1	Ring	Anneau	Aro
25	3441631M91	1		1	Rod, Piston	Tige de vérin	Vástago cilindro
26		23	Ref. 23	1	Rod, Piston	Tige de vérin	Vástago cilindro
27	3623390M1	23		2	Bush	Bague	Casquillo
28	339608X1	1		1	Fitting, Grease	Graisseur	Engrasador
29	3623397M91		(B)	1	Kit, Parts	Lot de pièces	Juego de piezas

A Included in kit marked (B)
 Inclus dans jeu marqué (B)
 Incluido en juego marcado (B)

B Contains items marked (A)
 Comprend les pièces marquées (A)
 Incluye las piezas marcadas (A)



860 880 970 980
 TX860B TX870B
 TX970B

813 814 815 816 817 821 822 823 824 825 841 842 843 844 845 851 852 853 854
 855 921 922 923 931 932

67006C04.1

6199042M3

1

Jan-06

Loader Hydraulics
Circuit Hydraulique de Chargeur
Circuito hidráulico cargadora

Bucket Cylinder
Vérin de Godet
Gato de cuchara

Standard Specification
 Qualité Inférieure
 Baja especificación

7 in 1 Bucket
 7 in 1 Bucket
 7 in 1 Bucket

C-67007-03.1-A

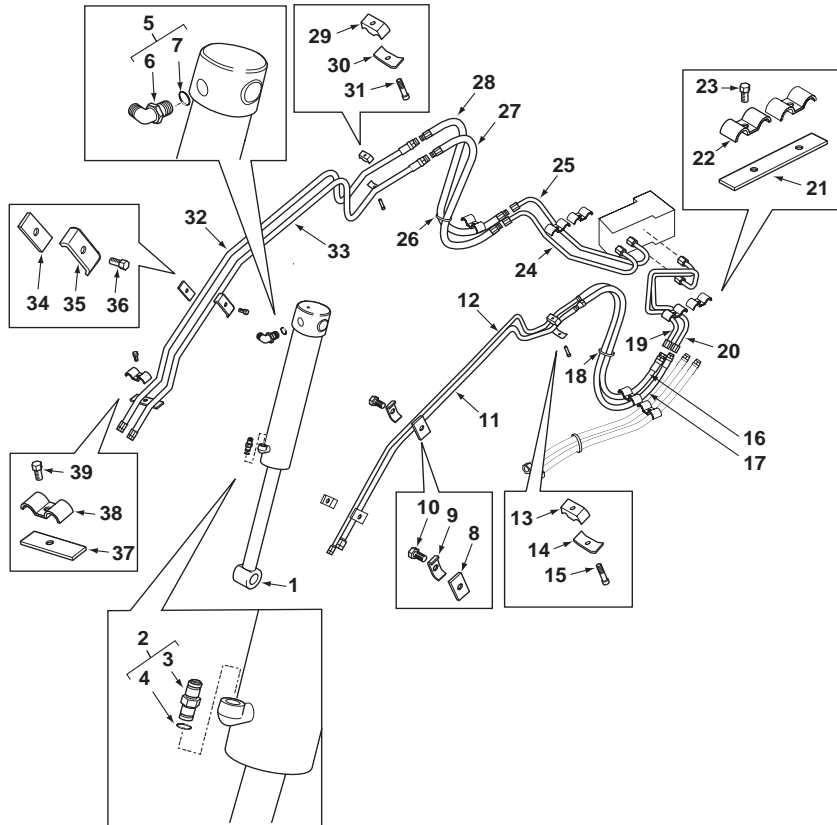

1	5000119M91	67007C04.1	1	Cylinder Assy	Ensemble de vérin	Gato, Conj.
2	835013M91		1	Connector Assy	Ensemble connexion	Conexión, Conj.
3		2	1	Union	Union	Unión
4	835024M1	2	1	O-Ring	Joint torique	Junta de tipo O
5	835007M91		1	Elbow, 90°	Coude à 90°	Codo, 90°
6		6	1	Elbow	Coude	Codo
7	835024M1	6	1	O-Ring	Joint torique	Junta de tipo O
8	6106109M1		2	Pad, Rubber	Plaque de caoutchouc	Placa, Caucho
9	6101228M1		2	Bracket, Clamp	Bride de fixation	Brida de fijación
10	339123X1	M8 x 20	2	Bolt	Boulon	Perno
11	6102461M91		1	Tube Assy	Tuyauterie	Conjunto de tubería
12	6102463M91		1	Tube Assy	Tuyauterie	Conjunto de tubería
13	3520528M2		1	Clamp	Collier de serrage	Argolla de cierre
14	3520534M1		1	Bracket, Clamp	Bride de fixation	Brida de fijación
15	339291X1	M8 x 55	1	Screw	Vis	Tornillo
16	6109793M91		1	Hose Assy	Ensemble de flexible	Flexible, Conj.
17	6109543M91		1	Hose Assy	Ensemble de flexible	Flexible, Conj.
18	1876229M1		1	Tie, Cable	Attache câble	Enlace de Cable
19	6109420M91		1	Tube Assy	Tuyauterie	Conjunto de tubería
20	6109422M91		1	Tube Assy	Tuyauterie	Conjunto de tubería
21	6101897M1		1	Pad, Rubber	Plaque de caoutchouc	Placa, Caucho
22	6101228M1		2	Bracket, Clamp	Bride de fixation	Brida de fijación
23	339124X1	M8 x 16	2	Screw	Vis	Tornillo
24	6109424M92		1	Tube Assy	Tuyauterie	Conjunto de tubería
25	6109426M92		1	Tube Assy	Tuyauterie	Conjunto de tubería
26	1876229M1		1	Tie, Cable	Attache câble	Enlace de Cable
27	6109804M91		1	Hose Assy	Ensemble de flexible	Flexible, Conj.
28	6109920M91		1	Hose Assy	Ensemble de flexible	Flexible, Conj.
29	3520538M2		1	Clamp	Collier de serrage	Argolla de cierre
30	3520534M1		1	Bracket, Clamp	Bride de fixation	Brida de fijación
31	339291X1	M8 x 55	1	Screw	Vis	Tornillo
32	6101236M91		1	Tube Assy	Tuyauterie	Conjunto de tubería
33	6101234M91		1	Tube Assy	Tuyauterie	Conjunto de tubería
34	6106109M1		1	Pad, Rubber	Plaque de caoutchouc	Placa, Caucho
35	6101228M1		1	Bracket, Clamp	Bride de fixation	Brida de fijación
36	339123X1	M8 x 20	1	Bolt	Boulon	Perno
37	6106109M1		1	Pad, Rubber	Plaque de caoutchouc	Placa, Caucho
38	6101228M1		1	Bracket, Clamp	Bride de fixation	Brida de fijación
39	339009X1	M8 x 35	1	Screw	Vis	Tornillo



820
TX760B

801 802 803 804 805 806 807 808 831 832 833 834

67007C03.1

6199042M3

1

Jan-06

Loader Hydraulics
Circuit Hydraulique de Chargeur
Circuito hidráulico cargadora

Bucket Cylinder
Vérin de Godet
Gato de cuchara

Standard Specification
 Qualité Inférieure
 Baja especificación

Pacoma
 Pacoma
 Pacoma

C-67007-04.1-A

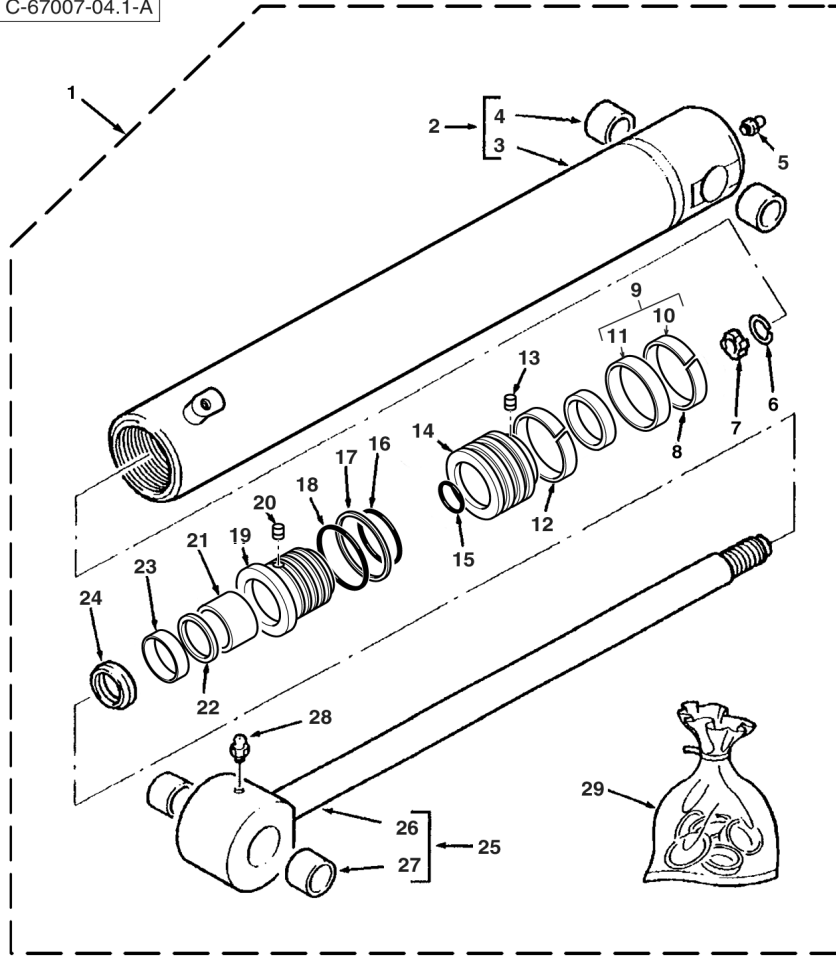

1	5000119M91		67007C03.1	1	Cylinder Assy	Ensemble de vérin	Gato, Conj.
2	5004071M91	1		1	Cylinder	Cylindre	Cilindro
3		2	Ref. 2	1	Tube, Cylinder	Cylindre de vérin	Cilindro de gato
4	3623390M1	2		2	Bush	Bague	Casquillo
5	339608X1	1		1	Fitting, Grease	Graisseur	Engrasador
6	3186587M1	1		1	Ring, Snap	Anneau d'arrêt	Anillo de resorte
7	3186586M1	1		1	Ring	Anneau	Aro
8	3484054M1	1 (A)		1	Ring	Anneau	Aro
9	3485214M91	1 (A)		1	Seal	Joint	Junta
10		9	Ref. 9	1	Seal	Joint	Junta
11		9	Ref. 9	1	Seal	Joint	Junta
12	3484054M1	1		1	Ring	Anneau	Aro
13	3402928M1	1		1	Screw	Vis	Tornillo
14	5004075M1	1		1	Piston	Piston	Pistón
15	359186X1	1 (A)		1	O-Ring	Joint torique	Junta de tipo O
16	359198X1	1 (A)		1	O-Ring	Joint torique	Junta de tipo O
17	378547X1	1 (A)		1	Ring	Anneau	Aro
18	3623670M1	1 (A)		1	O-Ring	Joint torique	Junta de tipo O
19	5004076M1	1		1	Bearing	Coussinet	Cojinete
20	3443386M1	1 (A)		1	Plug	Bouchon	Tapón
21	3484615M1	1 (A)		1	Ring	Anneau	Aro
22	3484055M1	1 (A)		1	Ring	Anneau	Aro
23	3485185M1	1 (A)		1	Seal	Joint	Junta
24	3487015M1	1 (A)		1	Ring	Anneau	Aro
25	3441631M91	1		1	Rod, Piston	Tige de vérin	Vástago cilindro
26		25	Ref. 25	1	Rod, Piston	Tige de vérin	Vástago cilindro
27	3623390M1	25		2	Bush	Bague	Casquillo
28	339608X1	1		1	Fitting, Grease	Graisseur	Engrasador
29	5004398M91		(B)	1	Kit, Parts	Lot de pièces	Juego de piezas

A Included in kit marked (B)
 Inclus dans jeu marqué (B)
 Incluido en juego marcado (B)

B Contains items marked (A)
 Comprend les pièces marquées (A)
 Incluye las piezas marcadas (A)



820
 TX760B

801 802 803 804 805 806 807 808 831 832 833 834

67007C04.1

6199042M3

1

Jan-06

Loader Hydraulics
Circuit Hydraulique de Chargeur
Circuito hidráulico cargadora

Bucket Cylinder
Vérin de Godet
Gato de cuchara

High Specification
 Qualité Supérieure
 Alta especificación

7 in 1 Bucket
 7 in 1 Bucket
 7 in 1 Bucket

C-67008-03.1-A

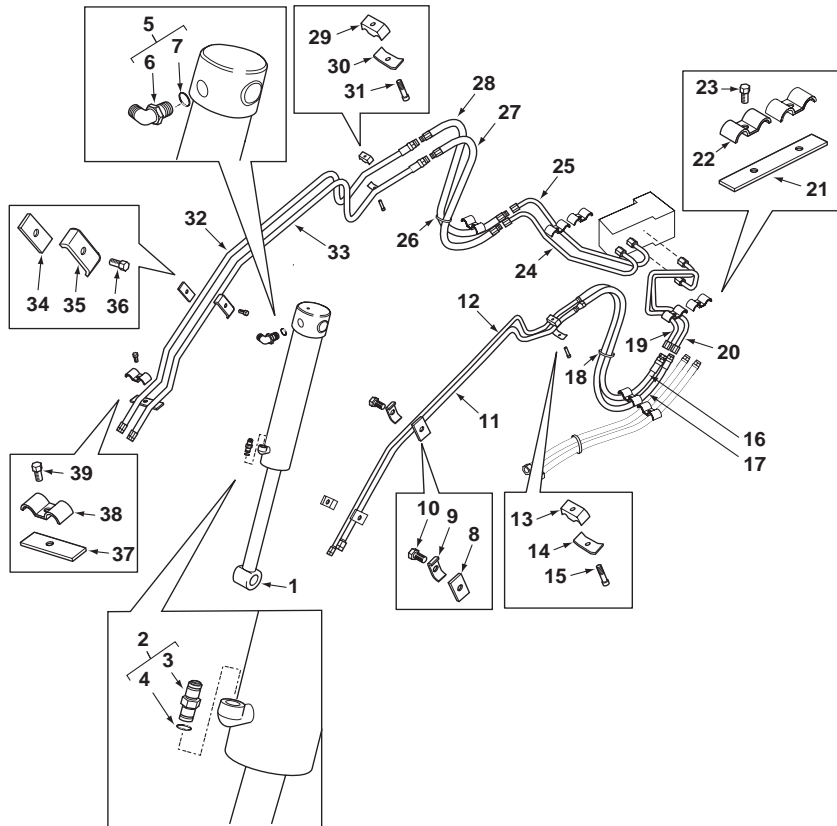

1	5000120M91	67008C04.1 1	1	Cylinder Assy	Ensemble de vérin	Gato, Conj.
2	835013M91		1	Connector Assy	Ensemble connexion	Conexión, Conj.
3		2 Ref. 2	1	Union	Union	Unión
4	835024M1	2	1	O-Ring	Joint torique	Junta de tipo O
5	835007M91		1	Elbow, 90°	Coude à 90°	Codo, 90°
6		6 Ref. 6	1	Elbow	Coude	Codo
7	835024M1	6	1	O-Ring	Joint torique	Junta de tipo O
8	6106109M1		2	Pad, Rubber	Plaque de caoutchouc	Placa, Caucho
9	6101228M1		2	Bracket, Clamp	Bride de fixation	Brida de fijación
10	339123X1	M8 x 20	2	Bolt	Boulon	Perno
11	6102461M91		1	Tube Assy	Tuyauterie	Conjunto de tubería
12	6102463M91		1	Tube Assy	Tuyauterie	Conjunto de tubería
13	3520528M2		1	Clamp	Collier de serrage	Argolla de cierre
14	3520534M1		1	Bracket, Clamp	Bride de fixation	Brida de fijación
15	339291X1	M8 x 55	1	Screw	Vis	Tornillo
16	6109793M91		1	Hose Assy	Ensemble de flexible	Flexible, Conj.
17	6109543M91		1	Hose Assy	Ensemble de flexible	Flexible, Conj.
18	1876229M1		1	Tie, Cable	Attache câble	Enlace de Cable
19	6109420M91		1	Tube Assy	Tuyauterie	Conjunto de tubería
20	6109422M91		1	Tube Assy	Tuyauterie	Conjunto de tubería
21	6101897M1		1	Pad, Rubber	Plaque de caoutchouc	Placa, Caucho
22	6101228M1		2	Bracket, Clamp	Bride de fixation	Brida de fijación
23	339124X1	M8 x 16	2	Screw	Vis	Tornillo
24	6109424M92		1	Tube Assy	Tuyauterie	Conjunto de tubería
25	6109426M92		1	Tube Assy	Tuyauterie	Conjunto de tubería
26	1876229M1		1	Tie, Cable	Attache câble	Enlace de Cable
27	6109804M91		1	Hose Assy	Ensemble de flexible	Flexible, Conj.
28	6109920M91		1	Hose Assy	Ensemble de flexible	Flexible, Conj.
29	3520538M2		1	Clamp	Collier de serrage	Argolla de cierre
30	3520534M1		1	Bracket, Clamp	Bride de fixation	Brida de fijación
31	339291X1	M8 x 55	1	Screw	Vis	Tornillo
32	6101236M91		1	Tube Assy	Tuyauterie	Conjunto de tubería
33	6101234M91		1	Tube Assy	Tuyauterie	Conjunto de tubería
34	6106109M1		1	Pad, Rubber	Plaque de caoutchouc	Placa, Caucho
35	6101228M1		1	Bracket, Clamp	Bride de fixation	Brida de fijación
36	339123X1	M8 x 20	1	Bolt	Boulon	Perno
37	6106109M1		1	Pad, Rubber	Plaque de caoutchouc	Placa, Caucho
38	6101228M1		1	Bracket, Clamp	Bride de fixation	Brida de fijación
39	339009X1	M8 x 35	1	Screw	Vis	Tornillo



860 880 970 980
 TX860B TX870B
 TX970B

813 814 815 816 817 821 822 823 824 825 841 842 843 844 845 851 852 853 854
 855 921 922 923 931 932

67008C03.1

6199042M3

1

Jan-06

Loader Hydraulics
Circuit Hydraulique de Chargeur
Circuito hidráulico cargadora

Bucket Cylinder
Vérin de Godet
Gato de cuchara

High Specification
 Qualité Supérieure
 Alta especificación

Pacoma
 Pacoma
 Pacoma

C-67008-04.1-A

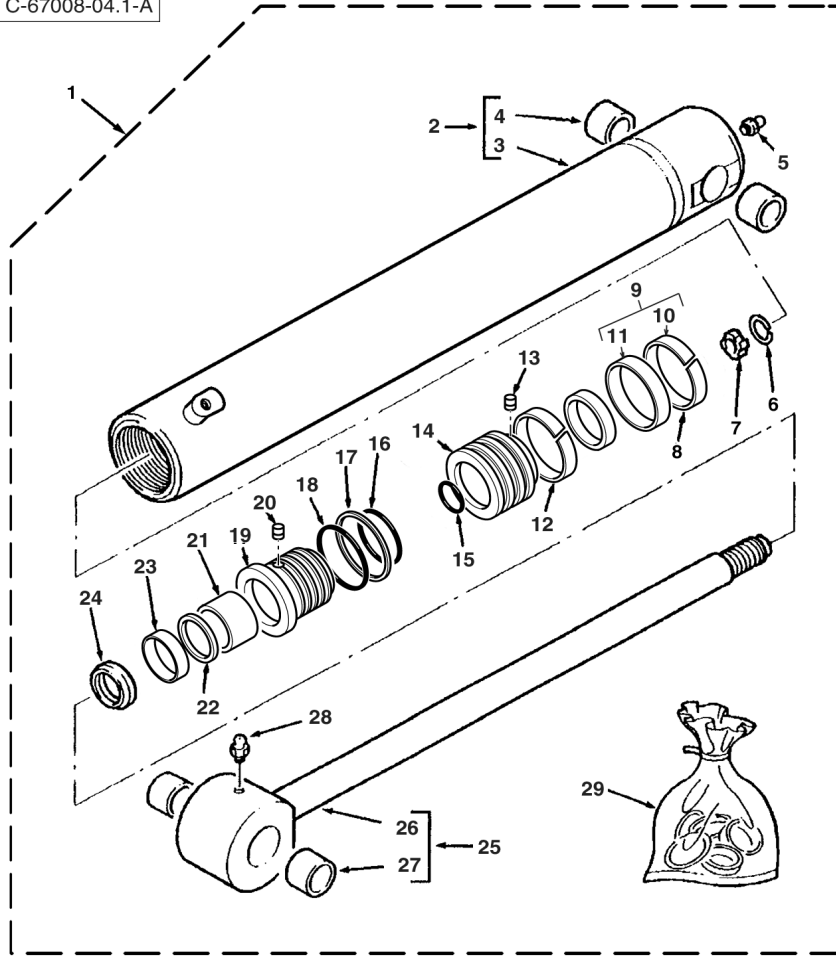

1	5000120M91	67008C03.1	1	Cylinder Assy	Ensemble de vérin	Gato, Conj.
2	5003936M91		1	Cylinder Assy	Ensemble de vérin	Gato, Conj.
3		Ref. 3	1	Tube, Cylinder	Cylindre de vérin	Cilindro de gato
4	3623390M1		2	Bush	Bague	Casquillo
5	339608X1		1	Fitting, Grease	Graisseur	Engrasador
6	3186587M1		1	Ring, Snap	Anneau d'arrêt	Anillo de resorte
7	3186586M1		1	Ring	Anneau	Aro
8	3442376M1	(A)	1	Ring	Anneau	Aro
9	3485249M91	(A)	1	Seal	Joint	Junta
10		Ref. 9	1	Seal	Joint	Junta
11		Ref. 9	1	Seal	Joint	Junta
12	3442376M1		1	Ring	Anneau	Aro
13	3402928M1		1	Screw	Vis	Tornillo
14	3485147M1		1	Piston	Piston	Pistón
15	359186X1	(A)	1	O-Ring	Joint torique	Junta de tipo O
16	359201X1	(A)	1	O-Ring	Joint torique	Junta de tipo O
17	1024334M1	(A)	1	Ring	Anneau	Aro
18	3487909M1	(A)	1	O-Ring	Joint torique	Junta de tipo O
19	5003941M1		1	Bearing	Coussinet	Cojinete
20	3443386M1	(A)	1	Plug	Bouchon	Tapón
21	3484615M1	(A)	1	Ring	Anneau	Aro
22	3484055M1	(A)	1	Ring	Anneau	Aro
23	3485185M1	(A)	1	Seal	Joint	Junta
24	3487015M1	(A)	1	Ring	Anneau	Aro
25	3441631M91		1	Rod, Piston	Tige de vérin	Vástago cilindro
26		Ref. 23	1	Rod, Piston	Tige de vérin	Vástago cilindro
27	3623390M1		2	Bush	Bague	Casquillo
28	339608X1		1	Fitting, Grease	Graisseur	Engrasador
29	3623397M91	(B)	1	Kit, Parts	Lot de pièces	Juego de piezas

A Included in kit marked (B)
 Inclus dans jeu marqué (B)
 Incluido en juego marcado (B)

B Contains items marked (A)
 Comprend les pièces marquées (A)
 Incluye las piezas marcadas (A)



860 880 970 980
 TX860B TX870B
 TX970B

813 814 815 816 817 821 822 823 824 825 841 842 843 844 845 851 852 853 854
 855 921 922 923 931 932

67008C04.1

6199042M3

1

Jan-06

Loader Hydraulics
Circuit Hydraulique de Chargeur
Circuito hidráulico cargadora

Bucket Cylinder
Vérin de Godet
Gato de cuchara

Standard Specification
 Qualité Inférieure
 Baja especificación

C-67009-03.1-A

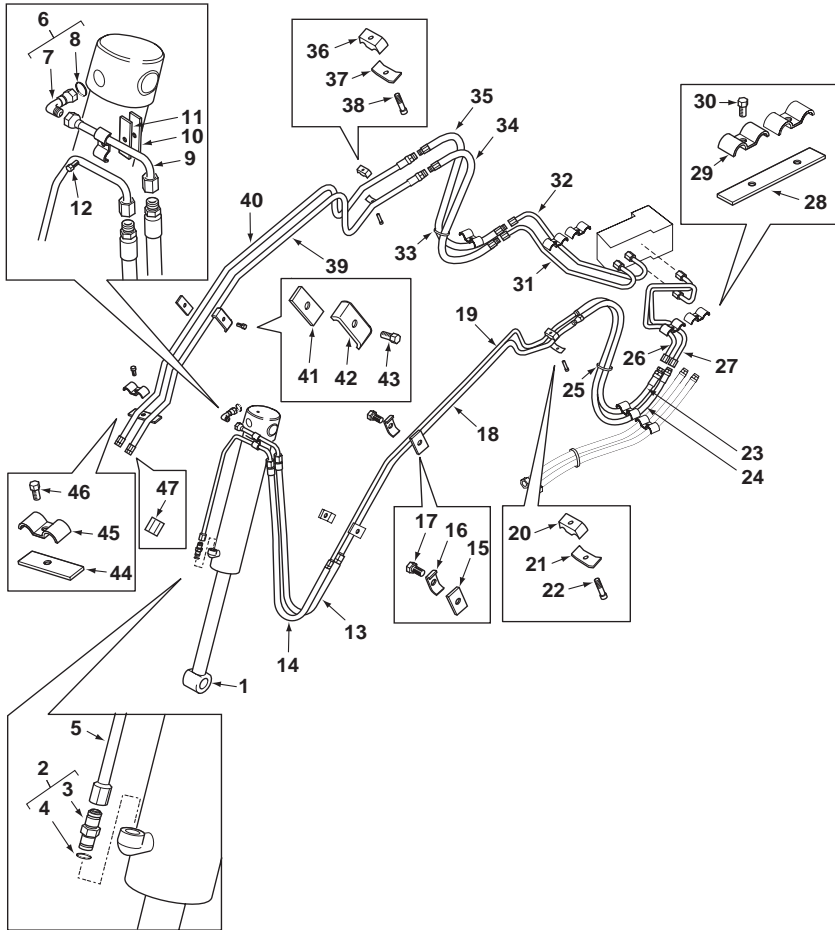

1	5000119M91	67009C04.1	1	Cylinder Assy	Ensemble de vérin	Gato, Conj.
2	835013M91		1	Connector Assy	Ensemble connexion	Conexión, Conj.
3		2	Ref. 2	Union	Union	Unión
4	835024M1	2		O-Ring	Joint torique	Junta de tipo O
5	6109514M91		1	Tube Assy	Tuyauterie	Conjunto de tubería
6	835007M91		1	Elbow, 90°	Coude à 90°	Codo, 90°
7		6	Ref. 6	Elbow	Coude	Codo
8	835024M1	6		O-Ring	Joint torique	Junta de tipo O
9	6109536M91		1	Tube Assy	Tuyauterie	Conjunto de tubería
10	6109526M91		1	Plate Assy	Ensemble de plaque	Placa, Conj.
11	6106109M1		1	Pad, Rubber	Plaque de caoutchouc	Placa, Caucho
12	339761X1	M8 x 25	1	Screw	Vis	Tornillo
13	6109530M91		1	Hose Assy	Ensemble de flexible	Flexible, Conj.
14	6109529M91		1	Hose Assy	Ensemble de flexible	Flexible, Conj.
15	6106109M1		2	Pad, Rubber	Plaque de caoutchouc	Placa, Caucho
16	6101228M1		2	Bracket, Clamp	Bride de fixation	Brida de fijación
17	339123X1	M8 x 20	2	Bolt	Boulon	Perno
18	6102461M91		1	Tube Assy	Tuyauterie	Conjunto de tubería
19	6102463M91		1	Tube Assy	Tuyauterie	Conjunto de tubería
20	3520528M2		1	Clamp	Collier de serrage	Argolla de cierre
21	3520534M1		1	Bracket, Clamp	Bride de fixation	Brida de fijación
22	339291X1	M8 x 55	1	Screw	Vis	Tornillo
23	6109793M91		1	Hose Assy	Ensemble de flexible	Flexible, Conj.
24	6109543M91		1	Hose Assy	Ensemble de flexible	Flexible, Conj.
25	1876229M1		1	Tie, Cable	Attache câble	Enlace de Cable
26	6109420M91		1	Tube Assy	Tuyauterie	Conjunto de tubería
27	6109422M91		1	Tube Assy	Tuyauterie	Conjunto de tubería
28	6101897M1		1	Pad, Rubber	Plaque de caoutchouc	Placa, Caucho
29	6101228M1		2	Bracket, Clamp	Bride de fixation	Brida de fijación
30	339124X1	M8 x 16	2	Screw	Vis	Tornillo
31	6109424M92		1	Tube Assy	Tuyauterie	Conjunto de tubería
32	6109426M92		1	Tube Assy	Tuyauterie	Conjunto de tubería
33	1876229M1		1	Tie, Cable	Attache câble	Enlace de Cable
34	6109804M91		1	Hose Assy	Ensemble de flexible	Flexible, Conj.
35	6109920M91		1	Hose Assy	Ensemble de flexible	Flexible, Conj.
36	3520538M2		1	Clamp	Collier de serrage	Argolla de cierre
37	3520534M1		1	Bracket, Clamp	Bride de fixation	Brida de fijación
38	339291X1	M8 x 55	1	Screw	Vis	Tornillo
39	6101236M91		1	Tube Assy	Tuyauterie	Conjunto de tubería
40	6101234M91		1	Tube Assy	Tuyauterie	Conjunto de tubería
41	6106109M1		1	Pad, Rubber	Plaque de caoutchouc	Placa, Caucho
42	6101228M1		1	Bracket, Clamp	Bride de fixation	Brida de fijación
43	339123X1	M8 x 20	1	Bolt	Boulon	Perno
44	6106109M1		1	Pad, Rubber	Plaque de caoutchouc	Placa, Caucho



820
TX760B

801 802 803 804 805 806 807 808 831 832 833 834

67009C03.1

6199042M3

1

Jan-06

Loader Hydraulics
Circuit Hydraulique de Chargeur
Circuito hidráulico cargadora

Bucket Cylinder
Vérin de Godet
Gato de cuchara

Standard Specification
 Qualité Inférieure
 Baja especificación

C-67009-03.1-A

45	6101228M1		1	Bracket, Clamp	Bride de fixation	Brida de fijación
46	339009X1	M8 x 35	1	Screw	Vis	Tornillo
47	356447X1	7/8	2	Plug, Blank-Off	Obturateur	Obturador

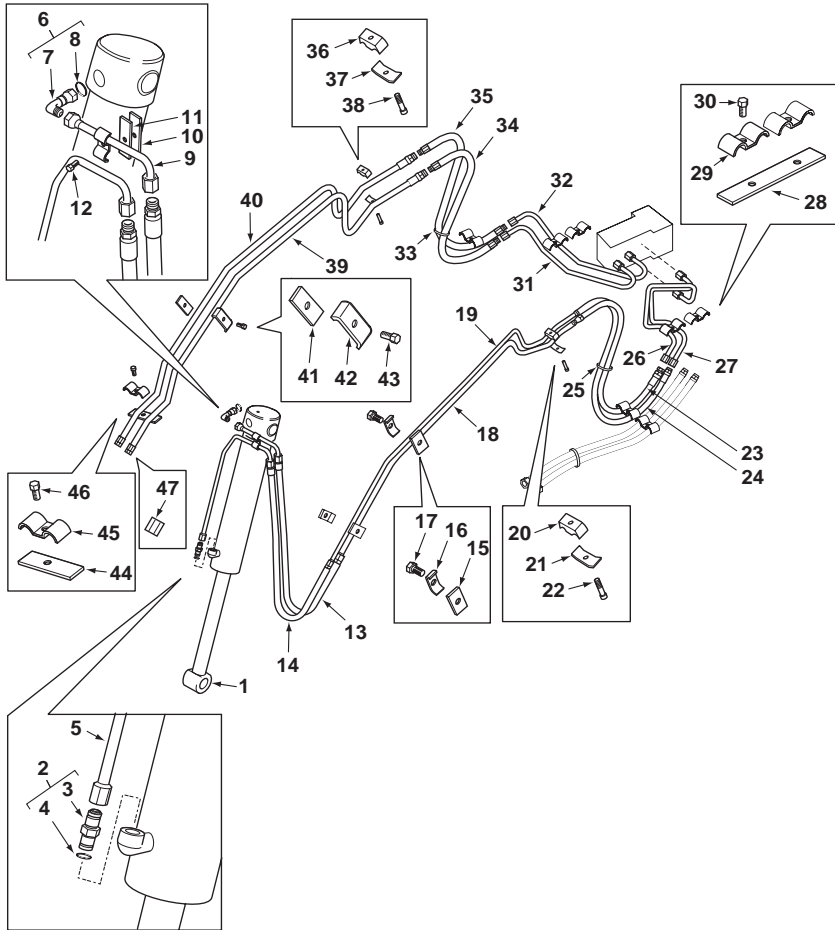

820
TX760B

801 802 803 804 805 806 807 808 831 832 833 834

Loader Hydraulics
Circuit Hydraulique de Chargeur
Circuito hidráulico cargadora

Bucket Cylinder
Vérin de Godet
Gato de cuchara

Standard Specification
 Qualité Inférieure
 Baja especificación

Pacoma
 Pacoma
 Pacoma

C-67009-04.1-A

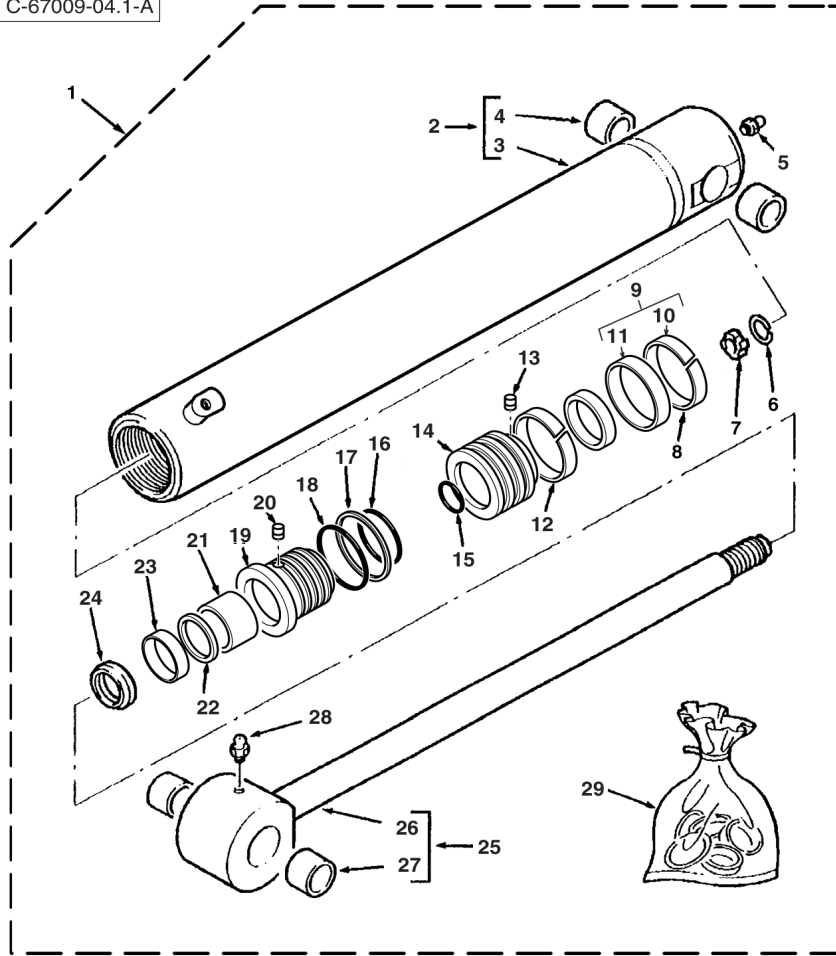

1	5000119M91		67009C03.1	1	Cylinder Assy	Ensemble de vérin	Gato, Conj.
2	5004071M91	1		1	Cylinder	Cylindre	Cilindro
3		2	Ref. 2	1	Tube, Cylinder	Cylindre de vérin	Cilindro de gato
4	3623390M1	2		2	Bush	Bague	Casquillo
5	339608X1	1		1	Fitting, Grease	Graisseur	Engrasador
6	3186587M1	1		1	Ring, Snap	Anneau d'arrêt	Anillo de resorte
7	3186586M1	1		1	Ring	Anneau	Aro
8	3484054M1	1 (A)		1	Ring	Anneau	Aro
9	3485214M91	1 (A)		1	Seal	Joint	Junta
10		9	Ref. 9	1	Seal	Joint	Junta
11		9	Ref. 9	1	Seal	Joint	Junta
12	3484054M1	1		1	Ring	Anneau	Aro
13	3402928M1	1		1	Screw	Vis	Tornillo
14	5004075M1	1		1	Piston	Piston	Pistón
15	359186X1	1 (A)		1	O-Ring	Joint torique	Junta de tipo O
16	359198X1	1 (A)		1	O-Ring	Joint torique	Junta de tipo O
17	378547X1	1 (A)		1	Ring	Anneau	Aro
18	3623670M1	1 (A)		1	O-Ring	Joint torique	Junta de tipo O
19	5004076M1	1		1	Bearing	Coussinet	Cojinete
20	3443386M1	1 (A)		1	Plug	Bouchon	Tapón
21	3484615M1	1 (A)		1	Ring	Anneau	Aro
22	3484055M1	1 (A)		1	Ring	Anneau	Aro
23	3485185M1	1 (A)		1	Seal	Joint	Junta
24	3487015M1	1 (A)		1	Ring	Anneau	Aro
25	3441631M91	1		1	Rod, Piston	Tige de vérin	Vástago cilindro
26		25	Ref. 25	1	Rod, Piston	Tige de vérin	Vástago cilindro
27	3623390M1	25		2	Bush	Bague	Casquillo
28	339608X1	1		1	Fitting, Grease	Graisseur	Engrasador
29	5004398M91		(B)	1	Kit, Parts	Lot de pièces	Juego de piezas

A Included in kit marked (B)
 Inclus dans jeu marqué (B)
 Incluido en juego marcado (B)

B Contains items marked (A)
 Comprend les pièces marquées (A)
 Incluye las piezas marcadas (A)



820
 TX760B

801 802 803 804 805 806 807 808 831 832 833 834

67009C04.1

6199042M3

1

Jan-06

Loader Hydraulics
Circuit Hydraulique de Chargeur
Circuito hidráulico cargadora

Bucket Cylinder
Vérin de Godet
Gato de cuchara

High Specification
 Qualité Supérieure
 Alta especificación

C-67010-03.1-A

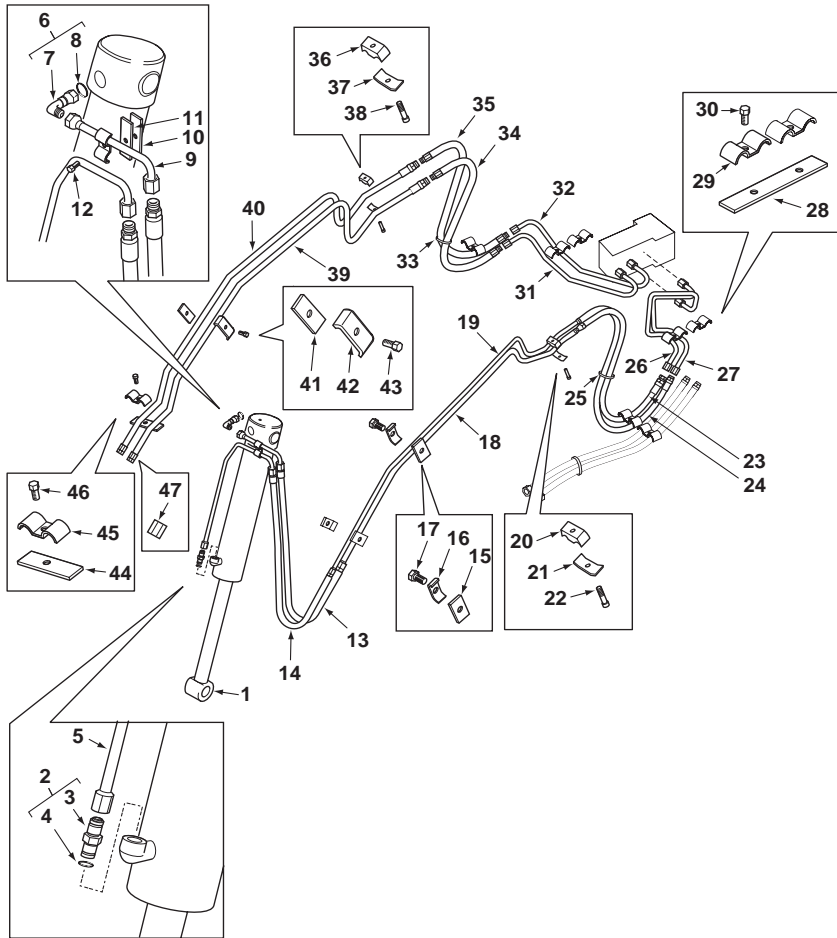

1	5000120M91	67010C04.1 1	1	Cylinder Assy	Ensemble de vérin	Gato, Conj.
2	835013M91		1	Connector Assy	Ensemble connexion	Conexión, Conj.
3		2 Ref. 2	1	Union	Union	Unión
4	835024M1	2	1	O-Ring	Joint torique	Junta de tipo O
5	6109514M91		1	Tube Assy	Tuyauterie	Conjunto de tubería
6	835007M91		1	Elbow, 90°	Coude à 90°	Codo, 90°
7		6 Ref. 6	1	Elbow	Coude	Codo
8	835024M1	6	1	O-Ring	Joint torique	Junta de tipo O
9	6109536M91		1	Tube Assy	Tuyauterie	Conjunto de tubería
10	6109526M91		1	Plate Assy	Ensemble de plaque	Placa, Conj.
11	6106109M1		1	Pad, Rubber	Plaque de caoutchouc	Placa, Caucho
12	339761X1	M8 x 25	1	Screw	Vis	Tornillo
13	6109530M91		1	Hose Assy	Ensemble de flexible	Flexible, Conj.
14	6109529M91		1	Hose Assy	Ensemble de flexible	Flexible, Conj.
15	6106109M1		2	Pad, Rubber	Plaque de caoutchouc	Placa, Caucho
16	6101228M1		2	Bracket, Clamp	Bride de fixation	Brida de fijación
17	339123X1	M8 x 20	2	Bolt	Boulon	Perno
18	6102461M91		1	Tube Assy	Tuyauterie	Conjunto de tubería
19	6102463M91		1	Tube Assy	Tuyauterie	Conjunto de tubería
20	3520528M2		1	Clamp	Collier de serrage	Argolla de cierre
21	3520534M1		1	Bracket, Clamp	Bride de fixation	Brida de fijación
22	339291X1	M8 x 55	1	Screw	Vis	Tornillo
23	6109793M91		1	Hose Assy	Ensemble de flexible	Flexible, Conj.
24	6109543M91		1	Hose Assy	Ensemble de flexible	Flexible, Conj.
25	1876229M1		1	Tie, Cable	Attache câble	Enlace de Cable
26	6109420M91		1	Tube Assy	Tuyauterie	Conjunto de tubería
27	6109422M91		1	Tube Assy	Tuyauterie	Conjunto de tubería
28	6101897M1		1	Pad, Rubber	Plaque de caoutchouc	Placa, Caucho
29	6101228M1		2	Bracket, Clamp	Bride de fixation	Brida de fijación
30	339124X1	M8 x 16	2	Screw	Vis	Tornillo
31	6109424M92		1	Tube Assy	Tuyauterie	Conjunto de tubería
32	6109426M92		1	Tube Assy	Tuyauterie	Conjunto de tubería
33	1876229M1		1	Tie, Cable	Attache câble	Enlace de Cable
34	6109804M91		1	Hose Assy	Ensemble de flexible	Flexible, Conj.
35	6109920M91		1	Hose Assy	Ensemble de flexible	Flexible, Conj.
36	3520538M2		1	Clamp	Collier de serrage	Argolla de cierre
37	3520534M1		1	Bracket, Clamp	Bride de fixation	Brida de fijación
38	339291X1	M8 x 55	1	Screw	Vis	Tornillo
39	6101236M91		1	Tube Assy	Tuyauterie	Conjunto de tubería
40	6101234M91		1	Tube Assy	Tuyauterie	Conjunto de tubería
41	6106109M1		1	Pad, Rubber	Plaque de caoutchouc	Placa, Caucho
42	6101228M1		1	Bracket, Clamp	Bride de fixation	Brida de fijación
43	339123X1	M8 x 20	1	Bolt	Boulon	Perno
44	6106109M1		1	Pad, Rubber	Plaque de caoutchouc	Placa, Caucho



860 880 970 980
 TX860B TX870B
 TX970B

809 810 811 812 813 814 815 816 817 821 822 823 824 825 841 842 843 844 845
 851 852 853 854 855 921 922 923 931 932

67010C03.1

6199042M3

1

Jan-06

Loader Hydraulics
Circuit Hydraulique de Chargeur
Circuito hidráulico cargadora

Bucket Cylinder
Vérin de Godet
Gato de cuchara

High Specification
 Qualité Supérieure
 Alta especificación

C-67010-03.1-A

45	6101228M1		1	Bracket, Clamp	Bride de fixation	Brida de fijación
46	339009X1	M8 x 35	1	Screw	Vis	Tornillo
47	356447X1	7/8	2	Plug, Blank-Off	Obturateur	Obturador

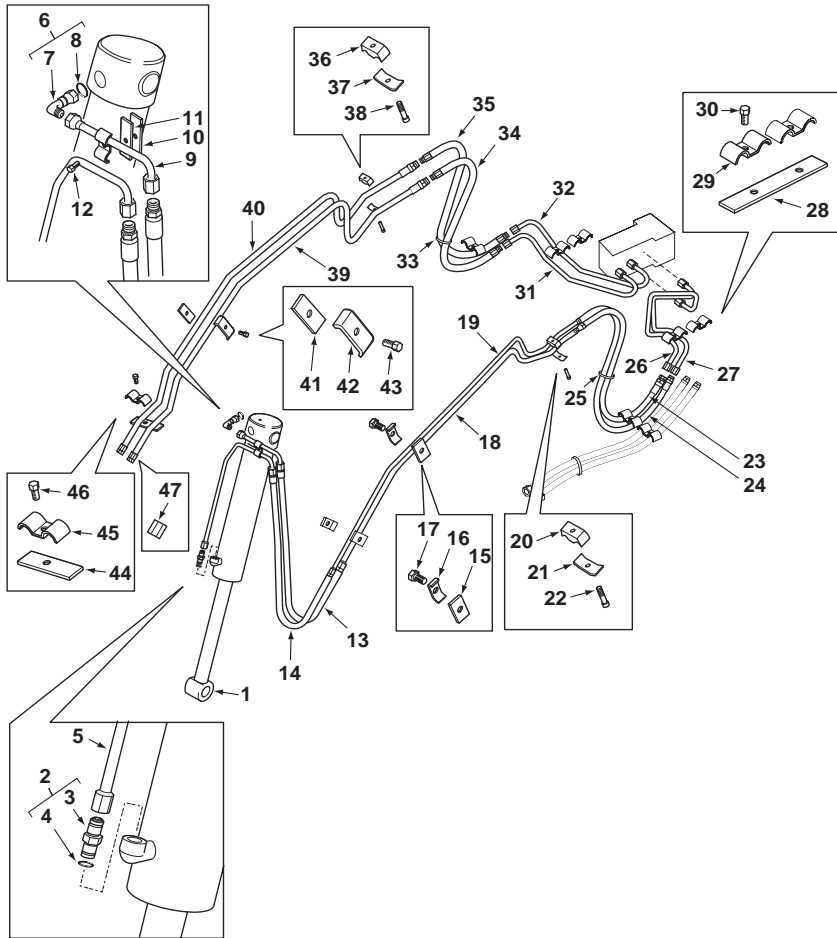

860 880 970 980
 TX860B TX870B
 TX970B

809 810 811 812 813 814 815 816 817 821 822 823 824 825 841 842 843 844 845
 851 852 853 854 855 921 922 923 931 932

67010C03.1

6199042M3

1

Jan-06

Loader Hydraulics
Circuit Hydraulique de Chargeur
Circuito hidráulico cargadora

Bucket Cylinder
Vérin de Godet
Gato de cuchara

High Specification
 Qualité Supérieure
 Alta especificación

Pacoma
 Pacoma
 Pacoma

C-67010-04.1-A

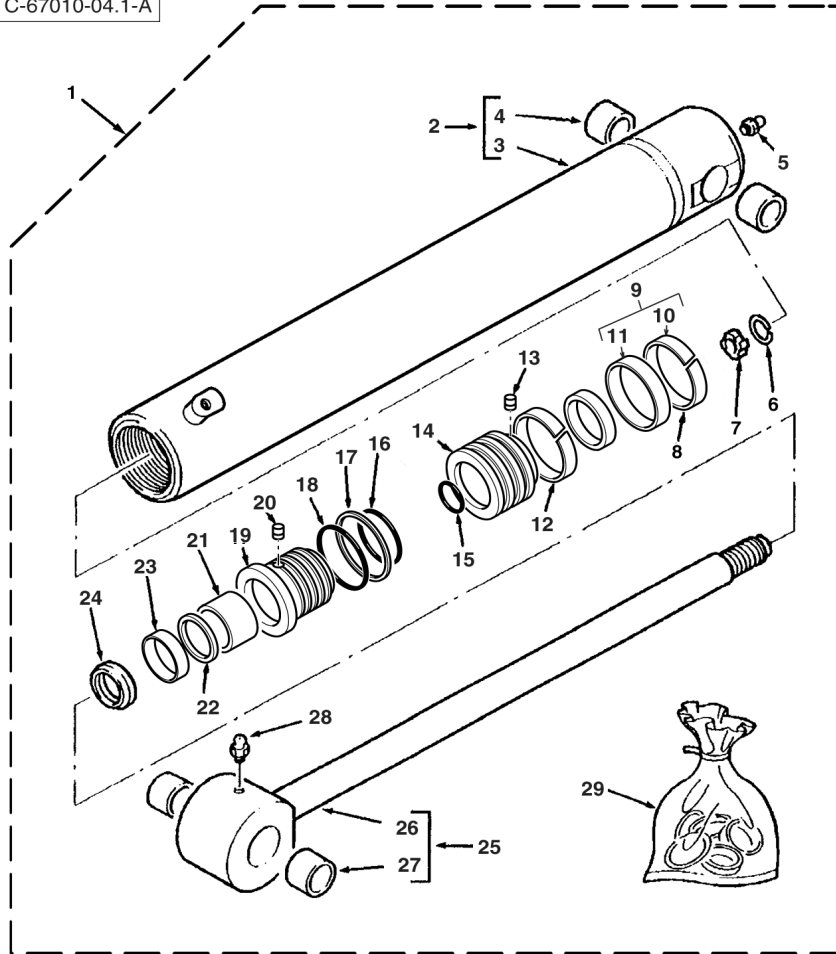

1	5000120M91	67010C03.1	1	Cylinder Assy	Ensemble de vérin	Gato, Conj.
2	5003936M91		1	Cylinder Assy	Ensemble de vérin	Gato, Conj.
3		Ref. 3	1	Tube, Cylinder	Cylindre de vérin	Cilindro de gato
4	3623390M1		2	Bush	Bague	Casquillo
5	339608X1		1	Fitting, Grease	Graisseur	Engrasador
6	3186587M1		1	Ring, Snap	Anneau d'arrêt	Anillo de resorte
7	3186586M1		1	Ring	Anneau	Aro
8	3442376M1	(A)	1	Ring	Anneau	Aro
9	3485249M91	(A)	1	Seal	Joint	Junta
10		Ref. 9	1	Seal	Joint	Junta
11		Ref. 9	1	Seal	Joint	Junta
12	3442376M1		1	Ring	Anneau	Aro
13	3402928M1		1	Screw	Vis	Tornillo
14	3485147M1		1	Piston	Piston	Pistón
15	359186X1	(A)	1	O-Ring	Joint torique	Junta de tipo O
16	359201X1	(A)	1	O-Ring	Joint torique	Junta de tipo O
17	1024334M1	(A)	1	Ring	Anneau	Aro
18	3487909M1	(A)	1	O-Ring	Joint torique	Junta de tipo O
19	5003941M1		1	Bearing	Coussinet	Cojinete
20	3443386M1	(A)	1	Plug	Bouchon	Tapón
21	3484615M1	(A)	1	Ring	Anneau	Aro
22	3484055M1	(A)	1	Ring	Anneau	Aro
23	3485185M1	(A)	1	Seal	Joint	Junta
24	3487015M1	(A)	1	Ring	Anneau	Aro
25	3441631M91		1	Rod, Piston	Tige de vérin	Vástago cilindro
26		Ref. 23	1	Rod, Piston	Tige de vérin	Vástago cilindro
27	3623390M1		2	Bush	Bague	Casquillo
28	339608X1		1	Fitting, Grease	Graisseur	Engrasador
29	3623397M91	(B)	1	Kit, Parts	Lot de pièces	Juego de piezas

A Included in kit marked (B)
 Inclus dans jeu marqué (B)
 Incluido en juego marcado (B)

B Contains items marked (A)
 Comprend les pièces marquées (A)
 Incluye las piezas marcadas (A)



860 880 970 980
 TX860B TX870B
 TX970B

809 810 811 812 813 814 815 816 817 821 822 823 824 825 841 842 843 844 845
 851 852 853 854 855 921 922 923 931 932

67010C04.1

6199042M3

1

Jan-06

Loader Hydraulics
Circuit Hydraulique de Chargeur
Circuito hidráulico cargadora

Bucket Cylinder
Vérin de Godet
Gato de cuchara

Standard Specification
 Qualité Inférieure
 Baja especificación

C-67011-03.1-A

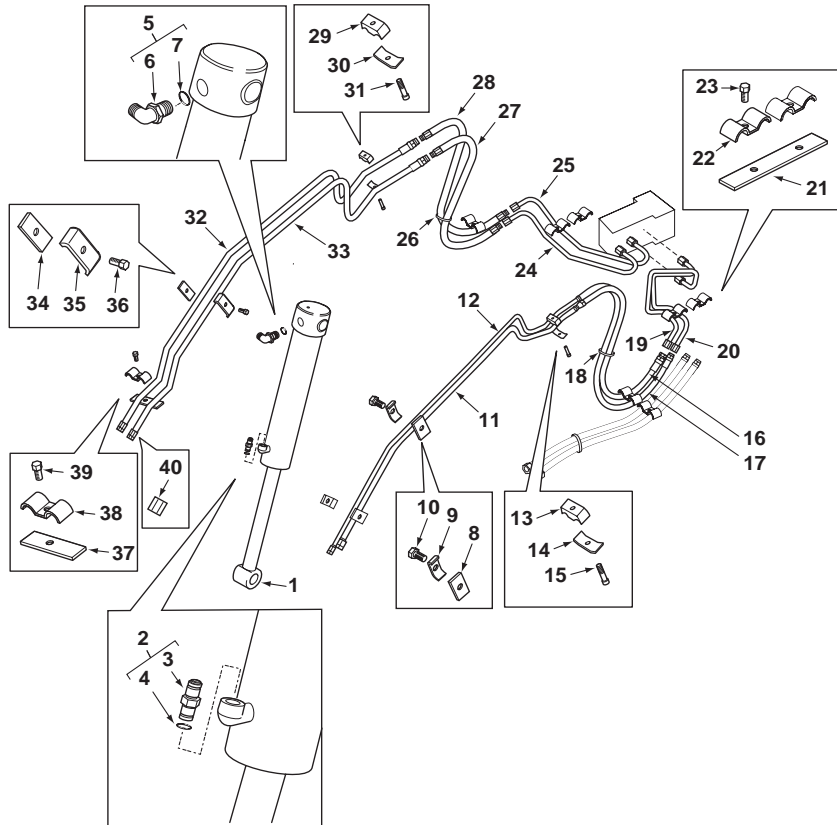

1	5000119M91	67011C04.1	1	Cylinder Assy	Ensemble de vérin	Gato, Conj.
2	835013M91		1	Connector Assy	Ensemble connexion	Conexión, Conj.
3		2 Ref. 2	1	Union	Union	Unión
4	835024M1	2	1	O-Ring	Joint torique	Junta de tipo O
5	835007M91		1	Elbow, 90°	Coude à 90°	Codo, 90°
6		6 Ref. 6	1	Elbow	Coude	Codo
7	835024M1	6	1	O-Ring	Joint torique	Junta de tipo O
8	6106109M1		2	Pad, Rubber	Plaque de caoutchouc	Placa, Caucho
9	6101228M1		2	Bracket, Clamp	Bride de fixation	Brida de fijación
10	339123X1	M8 x 20	2	Bolt	Boulon	Perno
11	6102461M91		1	Tube Assy	Tuyauterie	Conjunto de tubería
12	6102463M91		1	Tube Assy	Tuyauterie	Conjunto de tubería
13	3520528M2		1	Clamp	Collier de serrage	Argolla de cierre
14	3520534M1		1	Bracket, Clamp	Bride de fixation	Brida de fijación
15	339291X1	M8 x 55	1	Screw	Vis	Tornillo
16	6109793M91		1	Hose Assy	Ensemble de flexible	Flexible, Conj.
17	6109543M91		1	Hose Assy	Ensemble de flexible	Flexible, Conj.
18	1876229M1		1	Tie, Cable	Attache câble	Enlace de Cable
19	6109420M91		1	Tube Assy	Tuyauterie	Conjunto de tubería
20	6109422M91		1	Tube Assy	Tuyauterie	Conjunto de tubería
21	6101897M1		1	Pad, Rubber	Plaque de caoutchouc	Placa, Caucho
22	6101228M1		2	Bracket, Clamp	Bride de fixation	Brida de fijación
23	339124X1	M8 x 16	2	Screw	Vis	Tornillo
24	6109424M92		1	Tube Assy	Tuyauterie	Conjunto de tubería
25	6109426M92		1	Tube Assy	Tuyauterie	Conjunto de tubería
26	1876229M1		1	Tie, Cable	Attache câble	Enlace de Cable
27	6109804M91		1	Hose Assy	Ensemble de flexible	Flexible, Conj.
28	6109920M91		1	Hose Assy	Ensemble de flexible	Flexible, Conj.
29	3520538M2		1	Clamp	Collier de serrage	Argolla de cierre
30	3520534M1		1	Bracket, Clamp	Bride de fixation	Brida de fijación
31	339291X1	M8 x 55	1	Screw	Vis	Tornillo
32	6101236M91		1	Tube Assy	Tuyauterie	Conjunto de tubería
33	6101234M91		1	Tube Assy	Tuyauterie	Conjunto de tubería
34	6106109M1		1	Pad, Rubber	Plaque de caoutchouc	Placa, Caucho
35	6101228M1		1	Bracket, Clamp	Bride de fixation	Brida de fijación
36	339123X1	M8 x 20	1	Bolt	Boulon	Perno
37	6106109M1		1	Pad, Rubber	Plaque de caoutchouc	Placa, Caucho
38	6101228M1		1	Bracket, Clamp	Bride de fixation	Brida de fijación
39	339009X1	M8 x 35	1	Screw	Vis	Tornillo
40	356447X1	7/8	2	Plug, Blank-Off	Obturateur	Obturador



820
TX760B

801 802 803 804 805 806 807 808 831 832 833 834

67011C03.1

6199042M3

1

Jan-06

Loader Hydraulics
Circuit Hydraulique de Chargeur
Circuito hidráulico cargadora

Bucket Cylinder
Vérin de Godet
Gato de cuchara

Standard Specification
 Qualité Inférieure
 Baja especificación

Pacoma
 Pacoma
 Pacoma

C-67011-04.1-A

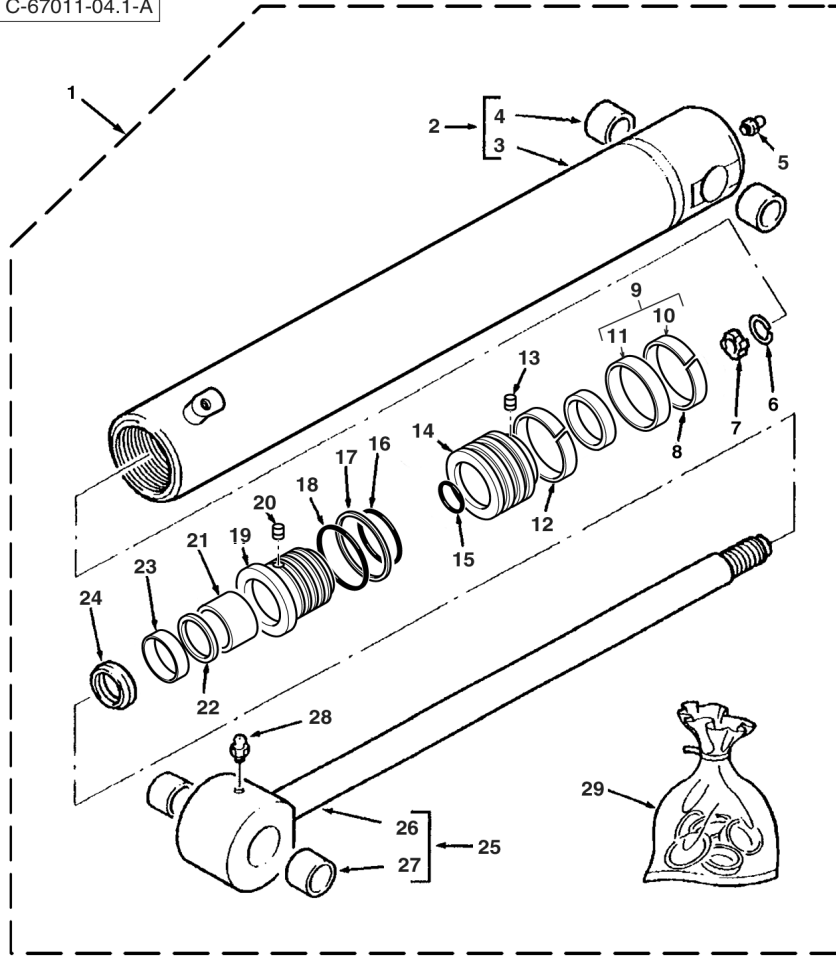

1	5000119M91		67011C03.1 1	1	Cylinder Assy	Ensemble de vérin	Gato, Conj.
2	5004071M91	1		1	Cylinder	Cylindre	Cilindro
3		2	Ref. 2	1	Tube, Cylinder	Cylindre de vérin	Cilindro de gato
4	3623390M1	2		2	Bush	Bague	Casquillo
5	339608X1	1		1	Fitting, Grease	Graisseur	Engrasador
6	3186587M1	1		1	Ring, Snap	Anneau d'arrêt	Anillo de resorte
7	3186586M1	1		1	Ring	Anneau	Aro
8	3484054M1	1 (A)		1	Ring	Anneau	Aro
9	3485214M91	1 (A)		1	Seal	Joint	Junta
10		9	Ref. 9	1	Seal	Joint	Junta
11		9	Ref. 9	1	Seal	Joint	Junta
12	3484054M1	1		1	Ring	Anneau	Aro
13	3402928M1	1		1	Screw	Vis	Tornillo
14	5004075M1	1		1	Piston	Piston	Pistón
15	359186X1	1 (A)		1	O-Ring	Joint torique	Junta de tipo O
16	359198X1	1 (A)		1	O-Ring	Joint torique	Junta de tipo O
17	378547X1	1 (A)		1	Ring	Anneau	Aro
18	3623670M1	1 (A)		1	O-Ring	Joint torique	Junta de tipo O
19	5004076M1	1		1	Bearing	Coussinet	Cojinete
20	3443386M1	1 (A)		1	Plug	Bouchon	Tapón
21	3484615M1	1 (A)		1	Ring	Anneau	Aro
22	3484055M1	1 (A)		1	Ring	Anneau	Aro
23	3485185M1	1 (A)		1	Seal	Joint	Junta
24	3487015M1	1 (A)		1	Ring	Anneau	Aro
25	3441631M91	1		1	Rod, Piston	Tige de vérin	Vástago cilindro
26		25	Ref. 25	1	Rod, Piston	Tige de vérin	Vástago cilindro
27	3623390M1	25		2	Bush	Bague	Casquillo
28	339608X1	1		1	Fitting, Grease	Graisseur	Engrasador
29	5004398M91		(B)	1	Kit, Parts	Lot de pièces	Juego de piezas

A Included in kit marked (B)
 Inclus dans jeu marqué (B)
 Incluido en juego marcado (B)

B Contains items marked (A)
 Comprend les pièces marquées (A)
 Incluye las piezas marcadas (A)



820
 TX760B

801 802 803 804 805 806 807 808 831 832 833 834

67011C04.1

6199042M3

1

Jan-06

Loader Hydraulics
Circuit Hydraulique de Chargeur
Circuito hidráulico cargadora

Bucket Cylinder
Vérin de Godet
Gato de cuchara

High Specification
 Qualité Supérieure
 Alta especificación

C-67012-03.1-A

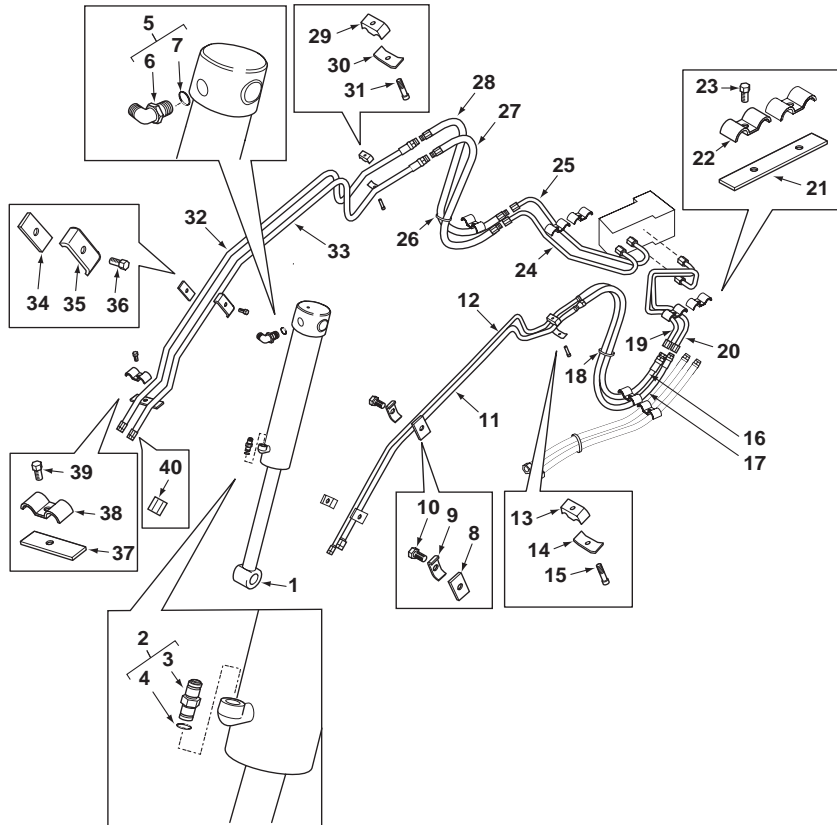

1	5000120M91	67012C04.1	1	Cylinder Assy	Ensemble de vérin	Gato, Conj.
2	835013M91		1	Connector Assy	Ensemble connexion	Conexión, Conj.
3		2	1	Union	Union	Unión
4	835024M1	2	1	O-Ring	Joint torique	Junta de tipo O
5	835007M91		1	Elbow, 90°	Coude à 90°	Codo, 90°
6		6	1	Elbow	Coude	Codo
7	835024M1	6	1	O-Ring	Joint torique	Junta de tipo O
8	6106109M1		2	Pad, Rubber	Plaque de caoutchouc	Placa, Caucho
9	6101228M1		2	Bracket, Clamp	Bride de fixation	Brida de fijación
10	339123X1	M8 x 20	2	Bolt	Boulon	Perno
11	6102461M91		1	Tube Assy	Tuyauterie	Conjunto de tubería
12	6102463M91		1	Tube Assy	Tuyauterie	Conjunto de tubería
13	3520528M2		1	Clamp	Collier de serrage	Argolla de cierre
14	3520534M1		1	Bracket, Clamp	Bride de fixation	Brida de fijación
15	339291X1	M8 x 55	1	Screw	Vis	Tornillo
16	6109793M91		1	Hose Assy	Ensemble de flexible	Flexible, Conj.
17	6109543M91		1	Hose Assy	Ensemble de flexible	Flexible, Conj.
18	1876229M1		1	Tie, Cable	Attache câble	Enlace de Cable
19	6109420M91		1	Tube Assy	Tuyauterie	Conjunto de tubería
20	6109422M91		1	Tube Assy	Tuyauterie	Conjunto de tubería
21	6101897M1		1	Pad, Rubber	Plaque de caoutchouc	Placa, Caucho
22	6101228M1		2	Bracket, Clamp	Bride de fixation	Brida de fijación
23	339124X1	M8 x 16	2	Screw	Vis	Tornillo
24	6109424M92		1	Tube Assy	Tuyauterie	Conjunto de tubería
25	6109426M92		1	Tube Assy	Tuyauterie	Conjunto de tubería
26	1876229M1		1	Tie, Cable	Attache câble	Enlace de Cable
27	6109804M91		1	Hose Assy	Ensemble de flexible	Flexible, Conj.
28	6109920M91		1	Hose Assy	Ensemble de flexible	Flexible, Conj.
29	3520538M2		1	Clamp	Collier de serrage	Argolla de cierre
30	3520534M1		1	Bracket, Clamp	Bride de fixation	Brida de fijación
31	339291X1	M8 x 55	1	Screw	Vis	Tornillo
32	6101236M91		1	Tube Assy	Tuyauterie	Conjunto de tubería
33	6101234M91		1	Tube Assy	Tuyauterie	Conjunto de tubería
34	6106109M1		1	Pad, Rubber	Plaque de caoutchouc	Placa, Caucho
35	6101228M1		1	Bracket, Clamp	Bride de fixation	Brida de fijación
36	339123X1	M8 x 20	1	Bolt	Boulon	Perno
37	6106109M1		1	Pad, Rubber	Plaque de caoutchouc	Placa, Caucho
38	6101228M1		1	Bracket, Clamp	Bride de fixation	Brida de fijación
39	339009X1	M8 x 35	1	Screw	Vis	Tornillo
40	356447X1	7/8	2	Plug, Blank-Off	Obturateur	Obturador



860 880 970 980
 TX860B TX870B
 TX970B

813 814 815 816 817 821 822 823 824 825 841 842 843 844 845 851 852 853 854
 855 921 922 923 931 932

67012C03.1

6199042M3

1

Jan-06

Loader Hydraulics
Circuit Hydraulique de Chargeur
Circuito hidráulico cargadora

Bucket Cylinder
Vérin de Godet
Gato de cuchara

High Specification
 Qualité Supérieure
 Alta especificación

Pacoma
 Pacoma
 Pacoma

C-67012-04.1-A

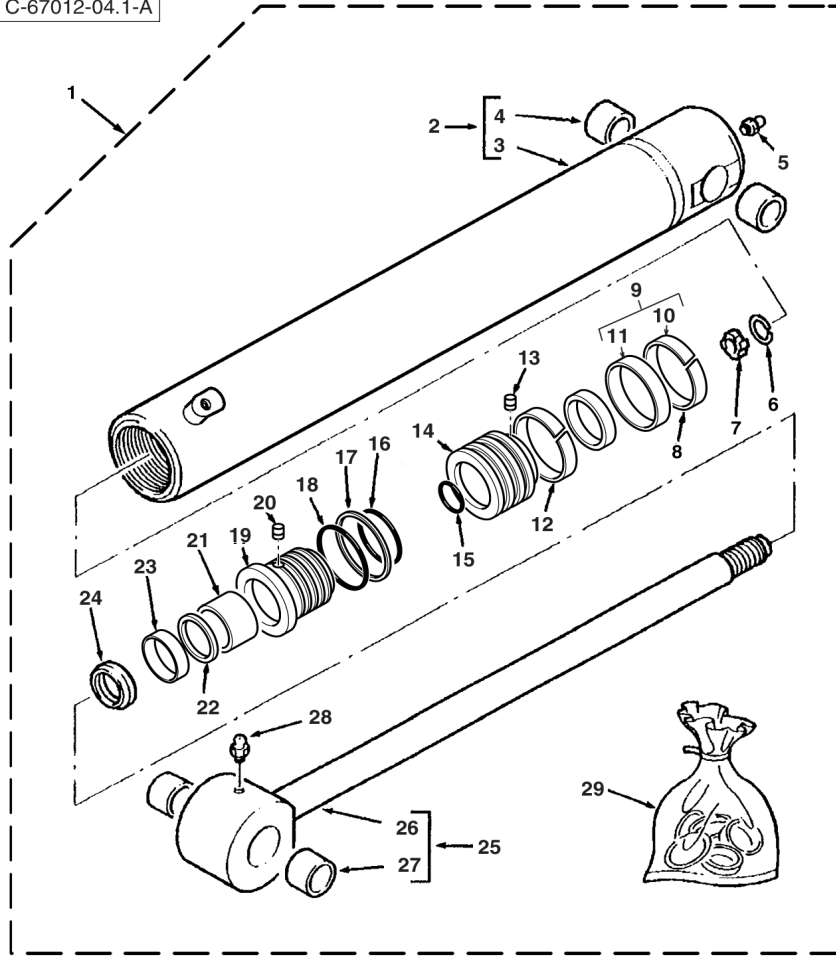

1	5000120M91		67012C03.1 1	1	Cylinder Assy	Ensemble de vérin	Gato, Conj.
2	5003936M91	1		1	Cylinder Assy	Ensemble de vérin	Gato, Conj.
3		3	Ref. 3	1	Tube, Cylinder	Cylindre de vérin	Cilindro de gato
4	3623390M1	3		2	Bush	Bague	Casquillo
5	339608X1	1		1	Fitting, Grease	Graisseur	Engrasador
6	3186587M1	1		1	Ring, Snap	Anneau d'arrêt	Anillo de resorte
7	3186586M1	1		1	Ring	Anneau	Aro
8	3442376M1	1 (A)		1	Ring	Anneau	Aro
9	3485249M91	1 (A)		1	Seal	Joint	Junta
10		9	Ref. 9	1	Seal	Joint	Junta
11		9	Ref. 9	1	Seal	Joint	Junta
12	3442376M1	1		1	Ring	Anneau	Aro
13	3402928M1	1		1	Screw	Vis	Tornillo
14	3485147M1	1		1	Piston	Piston	Pistón
15	359186X1	1 (A)		1	O-Ring	Joint torique	Junta de tipo O
16	359201X1	1 (A)		1	O-Ring	Joint torique	Junta de tipo O
17	1024334M1	1 (A)		1	Ring	Anneau	Aro
18	3487909M1	1 (A)		1	O-Ring	Joint torique	Junta de tipo O
19	5003941M1	1		1	Bearing	Coussinet	Cojinete
20	3443386M1	1 (A)		1	Plug	Bouchon	Tapón
21	3484615M1	1 (A)		1	Ring	Anneau	Aro
22	3484055M1	1 (A)		1	Ring	Anneau	Aro
23	3485185M1	1 (A)		1	Seal	Joint	Junta
24	3487015M1	1 (A)		1	Ring	Anneau	Aro
25	3441631M91	1		1	Rod, Piston	Tige de vérin	Vástago cilindro
26		23	Ref. 23	1	Rod, Piston	Tige de vérin	Vástago cilindro
27	3623390M1	23		2	Bush	Bague	Casquillo
28	339608X1	1		1	Fitting, Grease	Graisseur	Engrasador
29	3623397M91		(B)	1	Kit, Parts	Lot de pièces	Juego de piezas

A Included in kit marked (B)
 Inclus dans jeu marqué (B)
 Incluido en juego marcado (B)

B Contains items marked (A)
 Comprend les pièces marquées (A)
 Incluye las piezas marcadas (A)



860 880 970 980
 TX860B TX870B
 TX970B

813 814 815 816 817 821 822 823 824 825 841 842 843 844 845 851 852 853 854
 855 921 922 923 931 932

67012C04.1

6199042M3

1

Jan-06

Loader Hydraulics
Circuit Hydraulique de Chargeur
Circuito hidráulico cargadora

Lift Cylinder
Vérin de Levage
Gato de elevación

Standard Specification
 Qualité Inférieure
 Baja especificación

C-67001-01.1-A

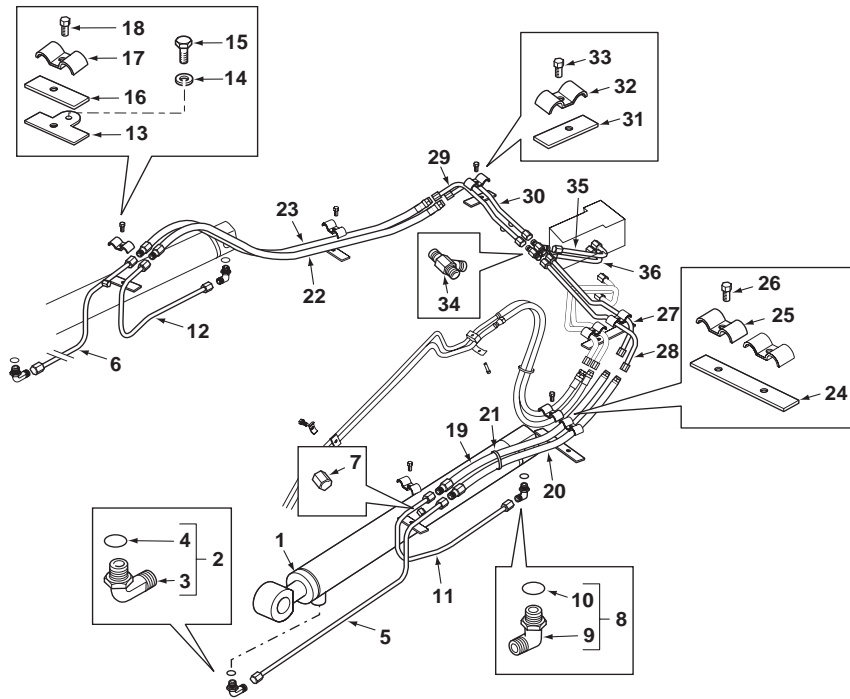

1	6109310M91		67001C02.1 1 Lift	2	Cylinder Assy	Ensemble de vérin	Gato, Conj.
2	835007M91			2	Elbow, 90°	Coude à 90°	Codo, 90°
3		2	Ref. 2	1	Elbow	Coude	Codo
4	835024M1	2		1	O-Ring	Joint torique	Junta de tipo O
5	6109544M91			1	Tube Assy	Tuyauterie	Conjunto de tubería
6	6109548M91			1	Tube Assy	Tuyauterie	Conjunto de tubería
7	356579X1			2	Cap	Chapeau	Sombbrero
8	835007M91			2	Elbow, 90°	Coude à 90°	Codo, 90°
9		8	Ref. 8	1	Elbow	Coude	Codo
10	835024M1	8		1	O-Ring	Joint torique	Junta de tipo O
11	6109546M91			1	Tube Assy	Tuyauterie	Conjunto de tubería
12	6109550M91			1	Tube Assy	Tuyauterie	Conjunto de tubería
13	6109791M91			2	Plate Assy	Ensemble de plaque	Placa, Conj.
14	339374X1	M8		2	Washer, Lock	Rondelle de blocage	Arandela de freno
15	339123X1	M8 x 20		2	Bolt	Boulon	Perno
16	6106109M1			2	Pad, Rubber	Plaque de caoutchouc	Placa, Caucho
17	6101228M1			2	Bracket, Clamp	Bride de fixation	Brida de fijación
18	339123X1	M8 x 20		2	Bolt	Boulon	Perno
19	6109919M91			1	Hose Assy	Ensemble de flexible	Flexible, Conj.
20	6109372M91			1	Hose Assy	Ensemble de flexible	Flexible, Conj.
21	1876229M1			2	Tie, Cable	Attache câble	Enlace de Cable
22	6109919M91			1	Hose Assy	Ensemble de flexible	Flexible, Conj.
23	6109372M91			1	Hose Assy	Ensemble de flexible	Flexible, Conj.
24	6101897M1			1	Pad, Rubber	Plaque de caoutchouc	Placa, Caucho
25	6101228M1			2	Bracket, Clamp	Bride de fixation	Brida de fijación
26	339124X1	M8 x 16		2	Screw	Vis	Tornillo
27	6109412M91			1	Tube Assy	Tuyauterie	Conjunto de tubería
28	6109414M91			1	Tube Assy	Tuyauterie	Conjunto de tubería
29	6109416M91			1	Tube Assy	Tuyauterie	Conjunto de tubería
30	6109418M91			1	Tube Assy	Tuyauterie	Conjunto de tubería
31	6106109M1			2	Pad, Rubber	Plaque de caoutchouc	Placa, Caucho
32	6101228M1			2	Bracket, Clamp	Bride de fixation	Brida de fijación
33	339124X1	M8 x 16		2	Screw	Vis	Tornillo
34	356561X1			2	Tee	Raccord en T	Te
35	6109428M91			1	Tube Assy	Tuyauterie	Conjunto de tubería
36	6109430M91			1	Tube Assy	Tuyauterie	Conjunto de tubería



820
TX760B

801 802 803 804 805 806 807 808 831 832 833 834

67001C01.1

6199042M3

1

Jan-06

Loader Hydraulics
Circuit Hydraulique de Chargeur
Circuito hidráulico cargadora

Lift Cylinder
Vérin de Levage
Gato de elevación

Standard Specification
 Qualité Inférieure
 Baja especificación

C-67001-02.1-B

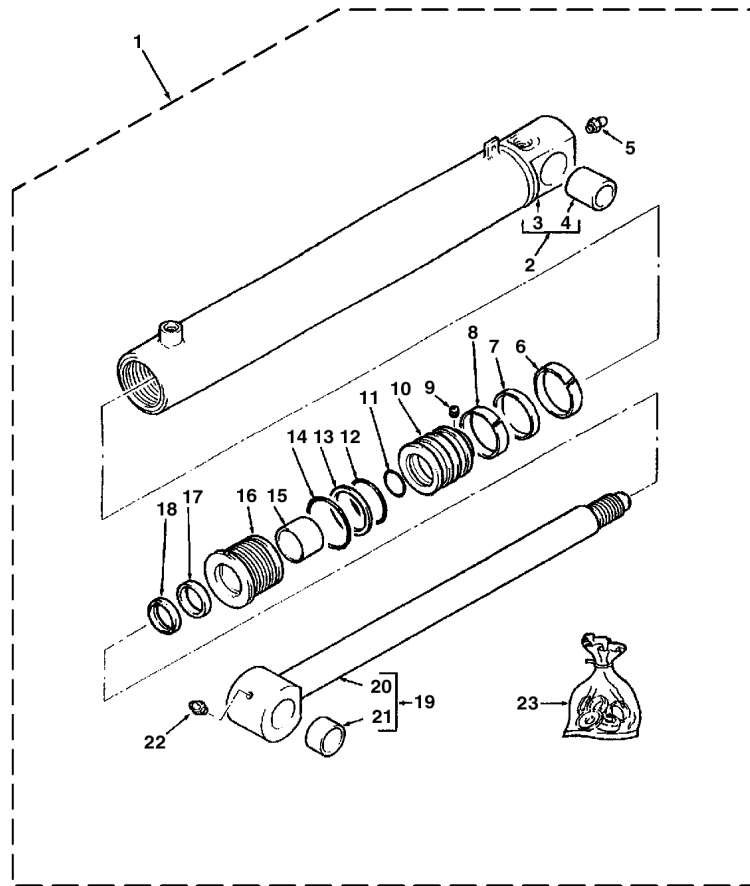

1	6109310M91		67001C01.1 1 Lift	2	Cylinder Assy	Ensemble de vérin	Gato, Conj.
2		1 (A)		1	Tube, Cylinder	Cylindre de vérin	Cilindro de gato
3		2	Ref. 2	1	Tube, Cylinder	Cylindre de vérin	Cilindro de gato
4	3623322M1	2		1	Bushing	Bague	Anillo
5	339608X1	1		1	Fitting, Grease	Graisser	Engrasador
6	3485889M1	1 (B)		1	Ring, Sealing	Bague d'étanchéité	Anillo, Estanqueidad
7	3485244M91	1 (B)		1	Seal Assy	Ensemble de joint	Junta, Conj.
8	3485889M1	1 (B)		1	Ring, Sealing	Bague d'étanchéité	Anillo, Estanqueidad
9	3402928M1	1		1	Screw	Vis	Tornillo
10	5001981M1	1		1	Piston, Cylinder	Piston de vérin	Pistón de gato
11	359183X1	1 (B)		1	O-Ring	Joint torique	Junta de tipo O
12	359191X1	1 (B)		1	O-Ring	Joint torique	Junta de tipo O
13	378543X1	1 (B)		1	Ring, Backup	Contre-joint	ContraJunta
14	3623640M1	1 (B)		1	O-Ring	Joint torique	Junta de tipo O
15	3443550M1	1 (B)		1	Ring	Anneau	Aro
16	5001980M1	1		1	Gland, Cylinder	Palier de vérin	Palier de gato
17	3403067M1	1 (B)		1	Ring, Sealing	Bague d'étanchéité	Anillo, Estanqueidad
18	1606058M1	1 (B)		1	Seal, Wiper	Joint de racléur	Junta raspador
19	3441920M91	1		1	Rod, Piston	Tige de vérin	Vástago cilindro
20		19	Ref. 19	1	Rod, Piston	Tige de vérin	Vástago cilindro
21	3623323M1	19		2	Bushing	Bague	Anillo
22	339608X1	1		1	Fitting, Grease	Graisser	Engrasador
23	5001982M91		(C)	1	Kit, Seal	Pochette de joints	Juego de juntas

- A Part number to be advised
 Référence pièce à demander
 Indicar número de pieza
- C Contains items marked (B)
 Comprend les pièces marquées (B)
 Incluye las piezas marcadas (B)

- B Included in kit marked (C)
 Inclus dans jeu marqué (C)
 Incluido en juego marcado (C)



820
 TX760B

801 802 803 804 805 806 807 808 831 832 833 834

67001C02.1

6199042M3

1

Jan-06

Loader Hydraulics
Circuit Hydraulique de Chargeur
Circuito hidráulico cargadora

Lift Cylinder
Vérin de Levage
Gato de elevación

High Specification
Qualité Supérieure
Alta especificación

C-67002-01.1-A

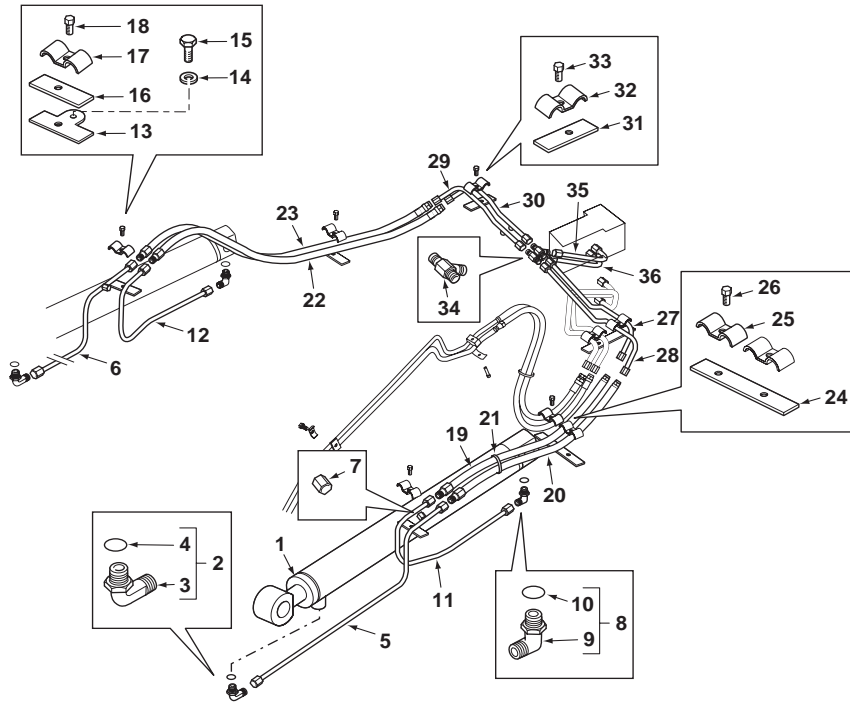

1	6109553M91	67002C02.1	1	2	Cylinder Assy	Ensemble de vérin	Gato, Conj.
2	835007M91			2	Elbow, 90°	Coude à 90°	Codo, 90°
3		2	Ref. 2	1	Elbow	Coude	Codo
4	835024M1	2		1	O-Ring	Joint torique	Junta de tipo O
5	6109544M91			1	Tube Assy	Tuyauterie	Conjunto de tubería
6	6109548M91			1	Tube Assy	Tuyauterie	Conjunto de tubería
7	356579X1			2	Cap	Chapeau	Sombbrero
8	835007M91			2	Elbow, 90°	Coude à 90°	Codo, 90°
9		8	Ref. 8	1	Elbow	Coude	Codo
10	835024M1	8		1	O-Ring	Joint torique	Junta de tipo O
11	6109546M91			1	Tube Assy	Tuyauterie	Conjunto de tubería
12	6109550M91			1	Tube Assy	Tuyauterie	Conjunto de tubería
13	6109791M91			2	Plate Assy	Ensemble de plaque	Placa, Conj.
14	339374X1	M8		2	Washer, Lock	Rondelle de blocage	Arandela de freno
15	339123X1	M8 x 20		2	Bolt	Boulon	Perno
16	6106109M1			2	Pad, Rubber	Plaque de caoutchouc	Placa, Caucho
17	6101228M1			2	Bracket, Clamp	Bride de fixation	Brida de fijación
18	339123X1	M8 x 20		2	Bolt	Boulon	Perno
19	6109919M91			1	Hose Assy	Ensemble de flexible	Flexible, Conj.
20	6109372M91			1	Hose Assy	Ensemble de flexible	Flexible, Conj.
21	1876229M1			2	Tie, Cable	Attache câble	Enlace de Cable
22	6109919M91			1	Hose Assy	Ensemble de flexible	Flexible, Conj.
23	6109372M91			1	Hose Assy	Ensemble de flexible	Flexible, Conj.
24	6101897M1			1	Pad, Rubber	Plaque de caoutchouc	Placa, Caucho
25	6101228M1			2	Bracket, Clamp	Bride de fixation	Brida de fijación
26	339124X1	M8 x 16		2	Screw	Vis	Tornillo
27	6109412M91			1	Tube Assy	Tuyauterie	Conjunto de tubería
28	6109414M91			1	Tube Assy	Tuyauterie	Conjunto de tubería
29	6109416M91			1	Tube Assy	Tuyauterie	Conjunto de tubería
30	6109418M91			1	Tube Assy	Tuyauterie	Conjunto de tubería
31	6106109M1			2	Pad, Rubber	Plaque de caoutchouc	Placa, Caucho
32	6101228M1			2	Bracket, Clamp	Bride de fixation	Brida de fijación
33	339124X1	M8 x 16		2	Screw	Vis	Tornillo
34	356561X1			2	Tee	Raccord en T	Te
35	6109428M91			1	Tube Assy	Tuyauterie	Conjunto de tubería
36	6109430M91			1	Tube Assy	Tuyauterie	Conjunto de tubería



860 880 970 980
 TX860B TX870B
 TX970B

809 810 811 812 813 814 815 816 817 821 822 823 824 825 841 842 843 844 845
 851 852 853 854 855 921 922 923 931 932

67002C01.1

6199042M3

1

Jan-06

Loader Hydraulics
Circuit Hydraulique de Chargeur
Circuito hidráulico cargadora

Lift Cylinder
Vérin de Levage
Gato de elevación

High Specification
Qualité Supérieure
Alta especificación

C-67002-02.1-B

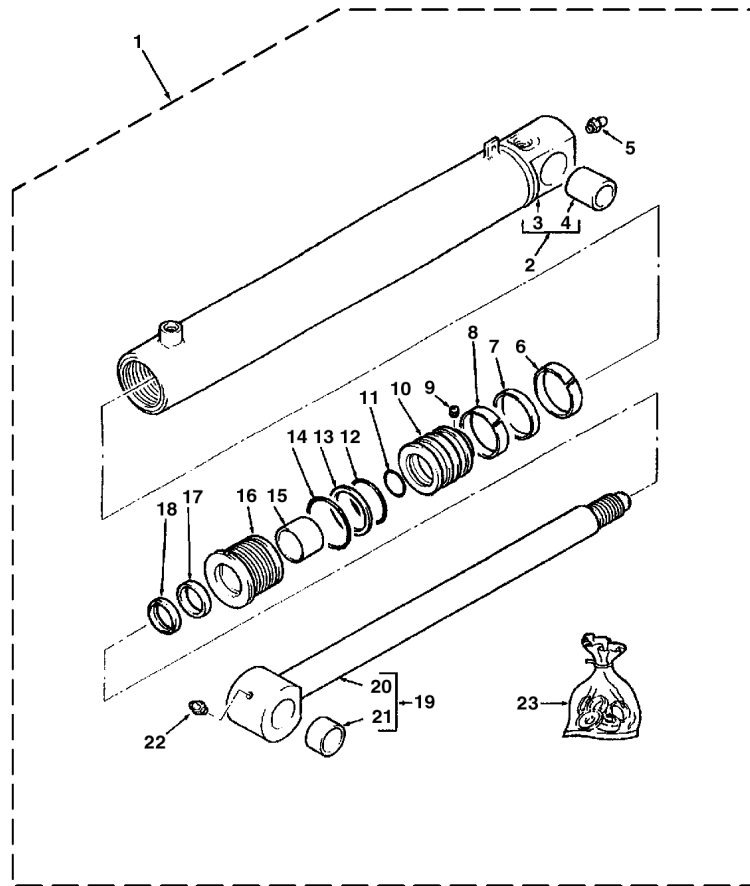

1	6109553M91		67002C01.1	1	2	Cylinder Assy	Ensemble de vérin	Gato, Conj.
2		1	(A)		1	Tube, Cylinder	Cylindre de vérin	Cilindro de gato
3		2	Ref. 2		1	Tube, Cylinder	Cylindre de vérin	Cilindro de gato
4	3623322M1	2			1	Bushing	Bague	Anillo
5	339608X1	1			1	Fitting, Grease	Graisneur	Engrasador
6	3485892M1	1	(B)		1	Ring, Sealing	Bague d'étanchéité	Anillo, Estanqueidad
7	3485245M91	1	(B)		1	Seal Assy	Ensemble de joint	Junta, Conj.
8	3485892M1	1	(B)		1	Ring, Sealing	Bague d'étanchéité	Anillo, Estanqueidad
9	3402928M1	1			1	Screw	Vis	Tornillo
10	3487180M1	1			1	Piston, Cylinder	Piston de vérin	Pistón de gato
11	359183X1	1	(B)		1	O-Ring	Joint torique	Junta de tipo O
12	359193X1	1	(B)		1	O-Ring	Joint torique	Junta de tipo O
13	1606735M1	1	(B)		1	Ring, Backup	Contre-joint	ContraJunta
14	3623641M1	1	(B)		1	O-Ring	Joint torique	Junta de tipo O
15	3443550M1	1	(B)		1	Ring	Anneau	Aro
16	5002159M1	1			1	Gland, Cylinder	Palier de vérin	Palier de gato
17	3403067M1	1	(B)		1	Ring, Sealing	Bague d'étanchéité	Anillo, Estanqueidad
18	1606058M1	1	(B)		1	Seal, Wiper	Joint de racleur	Junta raspador
19	3441920M91	1			1	Rod, Piston	Tige de vérin	Vástago cilindro
20		19	Ref. 19		1	Rod, Piston	Tige de vérin	Vástago cilindro
21	3623323M1	19			2	Bushing	Bague	Anillo
22	339608X1	1			1	Fitting, Grease	Graisneur	Engrasador
23	5001975M91		(C)		1	Kit, Seal	Pochette de joints	Juego de juntas

- A Part number to be advised
Référence pièce à demander
Indicar número de pieza
- C Contains items marked (B)
Comprend les pièces marquées (B)
Incluye las piezas marcadas (B)

- B Included in kit marked (C)
Inclus dans jeu marqué (C)
Incluido en juego marcado (C)



860 880 970 980
TX860B TX870B
TX970B

809 810 811 812 813 814 815 816 817 821 822 823 824 825 841 842 843 844 845
851 852 853 854 855 921 922 923 931 932

67002C02.1

6199042M3

1

Jan-06

Loader Hydraulics
Circuit Hydraulique de Chargeur
Circuito hidráulico cargadora

Lift Cylinder
Vérin de Levage
Gato de elevación

Standard Specification
 Qualité Inférieure
 Baja especificación

7 in 1 Bucket
 7 in 1 Bucket
 7 in 1 Bucket

C-67003-01.1-A

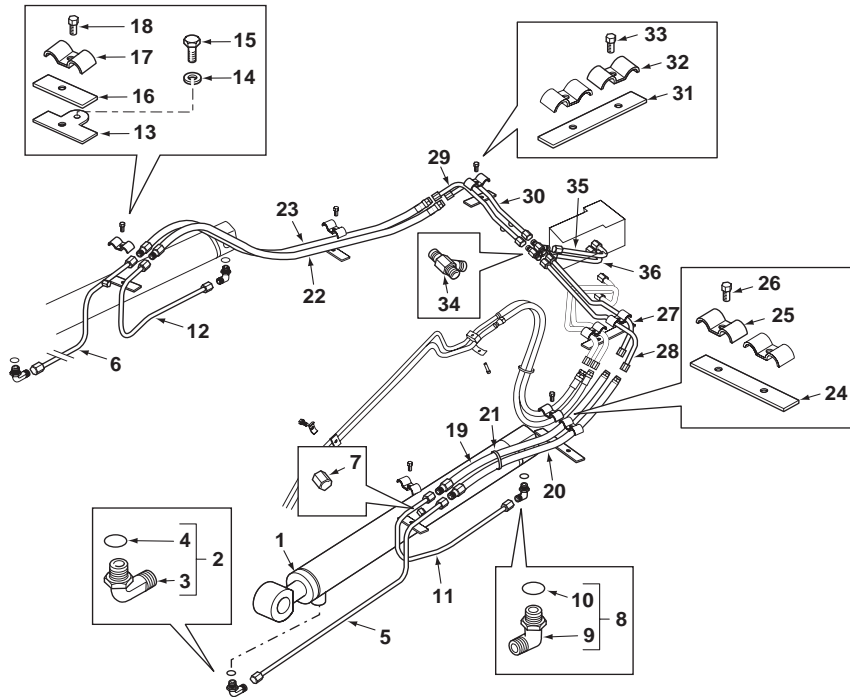

1	6109310M91	67003C02.1 1 Lift	2	Cylinder Assy	Ensemble de vérin	Gato, Conj.
2	835007M91		2	Elbow, 90°	Coude à 90°	Codo, 90°
3		2 Ref. 2	1	Elbow	Coude	Codo
4	835024M1	2	1	O-Ring	Joint torique	Junta de tipo O
5	6109544M91		1	Tube Assy	Tuyauterie	Conjunto de tubería
6	6109548M91		1	Tube Assy	Tuyauterie	Conjunto de tubería
7	356579X1		2	Cap	Chapeau	Sombbrero
8	835007M91		2	Elbow, 90°	Coude à 90°	Codo, 90°
9		8 Ref. 8	1	Elbow	Coude	Codo
10	835024M1	8	1	O-Ring	Joint torique	Junta de tipo O
11	6109546M91		1	Tube Assy	Tuyauterie	Conjunto de tubería
12	6109550M91		1	Tube Assy	Tuyauterie	Conjunto de tubería
13	6109791M91		2	Plate Assy	Ensemble de plaque	Placa, Conj.
14	339374X1	M8	2	Washer, Lock	Rondelle de blocage	Arandela de freno
15	339123X1	M8 x 20	2	Bolt	Boulon	Perno
16	6106109M1		2	Pad, Rubber	Plaque de caoutchouc	Placa, Caucho
17	6101228M1		2	Bracket, Clamp	Bride de fixation	Brida de fijación
18	339123X1	M8 x 20	2	Bolt	Boulon	Perno
19	6109919M91		1	Hose Assy	Ensemble de flexible	Flexible, Conj.
20	6109372M91		1	Hose Assy	Ensemble de flexible	Flexible, Conj.
21	1876229M1		2	Tie, Cable	Attache câble	Enlace de Cable
22	6109919M91		1	Hose Assy	Ensemble de flexible	Flexible, Conj.
23	6109372M91		1	Hose Assy	Ensemble de flexible	Flexible, Conj.
24	6101897M1		1	Pad, Rubber	Plaque de caoutchouc	Placa, Caucho
25	6101228M1		2	Bracket, Clamp	Bride de fixation	Brida de fijación
26	339124X1	M8 x 16	2	Screw	Vis	Tornillo
27	6109412M91		1	Tube Assy	Tuyauterie	Conjunto de tubería
28	6109414M91		1	Tube Assy	Tuyauterie	Conjunto de tubería
29	6109416M91		1	Tube Assy	Tuyauterie	Conjunto de tubería
30	6109418M91		1	Tube Assy	Tuyauterie	Conjunto de tubería
31	6101897M1		2	Pad, Rubber	Plaque de caoutchouc	Placa, Caucho
32	6101228M1		4	Bracket, Clamp	Bride de fixation	Brida de fijación
33	339124X1	M8 x 16	4	Screw	Vis	Tornillo
34	356561X1		2	Tee	Raccord en T	Te
35	6109428M91		1	Tube Assy	Tuyauterie	Conjunto de tubería
36	6109430M91		1	Tube Assy	Tuyauterie	Conjunto de tubería



820 880
 TX760B TX860B
 TX870B

801 802 803 804 805 806 807 808 831 832 833 834 842 844 852 854

67003C01.1

6199042M3

1

Jan-06

Loader Hydraulics
Circuit Hydraulique de Chargeur
Circuito hidráulico cargadora

Lift Cylinder
Vérin de Levage
Gato de elevación

Standard Specification
 Qualité Inférieure
 Baja especificación

C-67003-02.1-B

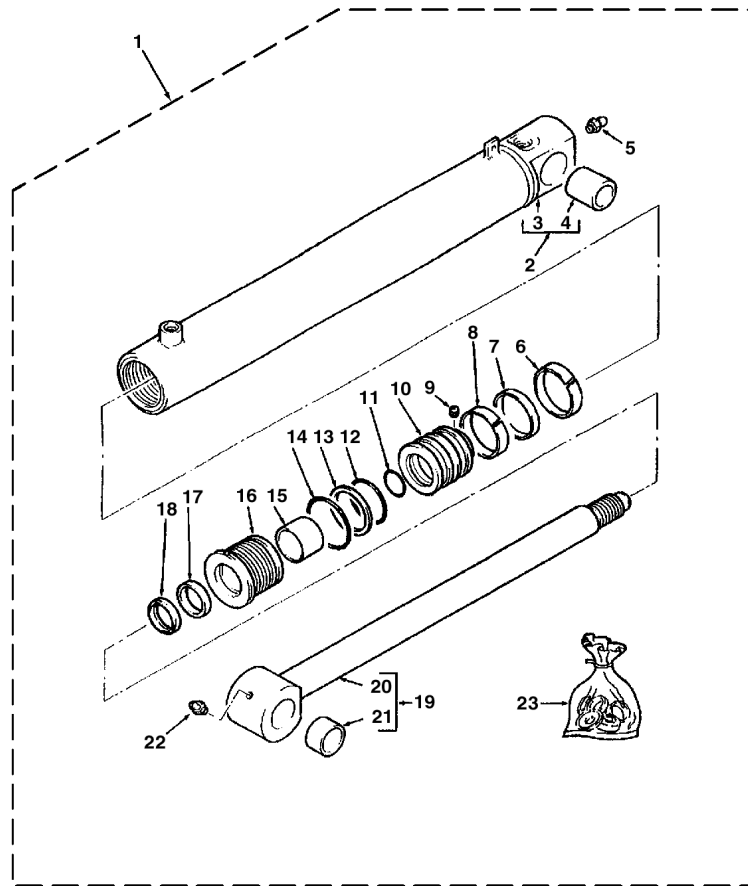

1	6109310M91		67003C01.1 1 Lift	2	Cylinder Assy	Ensemble de vérin	Gato, Conj.
2		1 (A)		1	Tube, Cylinder	Cylindre de vérin	Cilindro de gato
3		2	Ref. 2	1	Tube, Cylinder	Cylindre de vérin	Cilindro de gato
4	3623322M1	2		1	Bushing	Bague	Anillo
5	339608X1	1		1	Fitting, Grease	Graisneur	Engrasador
6	3485889M1	1 (B)		1	Ring, Sealing	Bague d'étanchéité	Anillo, Estanqueidad
7	3485244M91	1 (B)		1	Seal Assy	Ensemble de joint	Junta, Conj.
8	3485889M1	1 (B)		1	Ring, Sealing	Bague d'étanchéité	Anillo, Estanqueidad
9	3402928M1	1		1	Screw	Vis	Tornillo
10	5001981M1	1		1	Piston, Cylinder	Piston de vérin	Pistón de gato
11	359183X1	1 (B)		1	O-Ring	Joint torique	Junta de tipo O
12	359191X1	1 (B)		1	O-Ring	Joint torique	Junta de tipo O
13	378543X1	1 (B)		1	Ring, Backup	Contre-joint	ContraJunta
14	3623640M1	1 (B)		1	O-Ring	Joint torique	Junta de tipo O
15	3443550M1	1 (B)		1	Ring	Anneau	Aro
16	5001980M1	1		1	Gland, Cylinder	Palier de vérin	Palier de gato
17	3403067M1	1 (B)		1	Ring, Sealing	Bague d'étanchéité	Anillo, Estanqueidad
18	1606058M1	1 (B)		1	Seal, Wiper	Joint de racleur	Junta raspador
19	3441920M91	1		1	Rod, Piston	Tige de vérin	Vástago cilindro
20		19	Ref. 19	1	Rod, Piston	Tige de vérin	Vástago cilindro
21	3623323M1	19		2	Bushing	Bague	Anillo
22	339608X1	1		1	Fitting, Grease	Graisneur	Engrasador
23	5001982M91		(C)	1	Kit, Seal	Pochette de joints	Juego de juntas

- A Part number to be advised
 Référence pièce à demander
 Indicar número de pieza
- C Contains items marked (B)
 Comprend les pièces marquées (B)
 Incluye las piezas marcadas (B)

- B Included in kit marked (C)
 Inclus dans jeu marqué (C)
 Incluido en juego marcado (C)



820 880
 TX760B TX860B
 TX870B

801 802 803 804 805 806 807 808 831 832 833 834 842 844 852 854

67003C02.1

6199042M3

1

Jan-06

Loader Hydraulics
Circuit Hydraulique de Chargeur
Circuito hidráulico cargadora

Lift Cylinder
Vérin de Levage
Gato de elevación

High Specification
 Qualité Supérieure
 Alta especificación

7 in 1 Bucket
 7 in 1 Bucket
 7 in 1 Bucket

C-67004-01.1-A

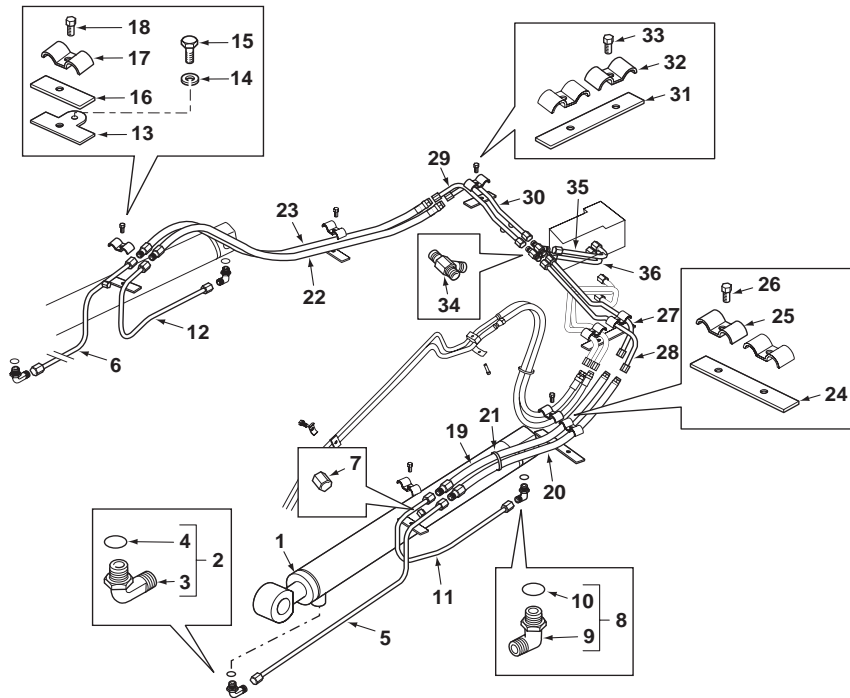

1	6109553M91	67004C02.1	1	2	Cylinder Assy	Ensemble de vérin	Gato, Conj.
2	835007M91			2	Elbow, 90°	Coude à 90°	Codo, 90°
3		2	Ref. 2	1	Elbow	Coude	Codo
4	835024M1	2		1	O-Ring	Joint torique	Junta de tipo O
5	6109544M91			1	Tube Assy	Tuyauterie	Conjunto de tubería
6	6109548M91			1	Tube Assy	Tuyauterie	Conjunto de tubería
7	356579X1			2	Cap	Chapeau	Sombbrero
8	835007M91			2	Elbow, 90°	Coude à 90°	Codo, 90°
9		8	Ref. 8	1	Elbow	Coude	Codo
10	835024M1	8		1	O-Ring	Joint torique	Junta de tipo O
11	6109546M91			1	Tube Assy	Tuyauterie	Conjunto de tubería
12	6109550M91			1	Tube Assy	Tuyauterie	Conjunto de tubería
13	6109791M91			2	Plate Assy	Ensemble de plaque	Placa, Conj.
14	339374X1	M8		2	Washer, Lock	Rondelle de blocage	Arandela de freno
15	339123X1	M8 x 20		2	Bolt	Boulon	Perno
16	6106109M1			2	Pad, Rubber	Plaque de caoutchouc	Placa, Caucho
17	6101228M1			2	Bracket, Clamp	Bride de fixation	Brida de fijación
18	339123X1	M8 x 20		2	Bolt	Boulon	Perno
19	6109919M91			1	Hose Assy	Ensemble de flexible	Flexible, Conj.
20	6109372M91			1	Hose Assy	Ensemble de flexible	Flexible, Conj.
21	1876229M1			2	Tie, Cable	Attache câble	Enlace de Cable
22	6109919M91			1	Hose Assy	Ensemble de flexible	Flexible, Conj.
23	6109372M91			1	Hose Assy	Ensemble de flexible	Flexible, Conj.
24	6101897M1			1	Pad, Rubber	Plaque de caoutchouc	Placa, Caucho
25	6101228M1			2	Bracket, Clamp	Bride de fixation	Brida de fijación
26	339124X1	M8 x 16		2	Screw	Vis	Tornillo
27	6109412M91			1	Tube Assy	Tuyauterie	Conjunto de tubería
28	6109414M91			1	Tube Assy	Tuyauterie	Conjunto de tubería
29	6109416M91			1	Tube Assy	Tuyauterie	Conjunto de tubería
30	6109418M91			1	Tube Assy	Tuyauterie	Conjunto de tubería
31	6101897M1			2	Pad, Rubber	Plaque de caoutchouc	Placa, Caucho
32	6101228M1			4	Bracket, Clamp	Bride de fixation	Brida de fijación
33	339124X1	M8 x 16		4	Screw	Vis	Tornillo
34	356561X1			2	Tee	Raccord en T	Te
35	6109428M91			1	Tube Assy	Tuyauterie	Conjunto de tubería
36	6109430M91			1	Tube Assy	Tuyauterie	Conjunto de tubería



860 880 970 980
 TX860B TX870B
 TX970B

809 810 811 812 813 814 815 816 817 821 822 823 824 825 841 842 843 844 845
 851 852 853 854 855 921 922 923 931 932

67004C01.1

6199042M3

1

Jan-06

Loader Hydraulics
Circuit Hydraulique de Chargeur
Circuito hidráulico cargadora

Lift Cylinder
Vérin de Levage
Gato de elevación

High Specification
Qualité Supérieure
Alta especificación

C-67004-02.1-B

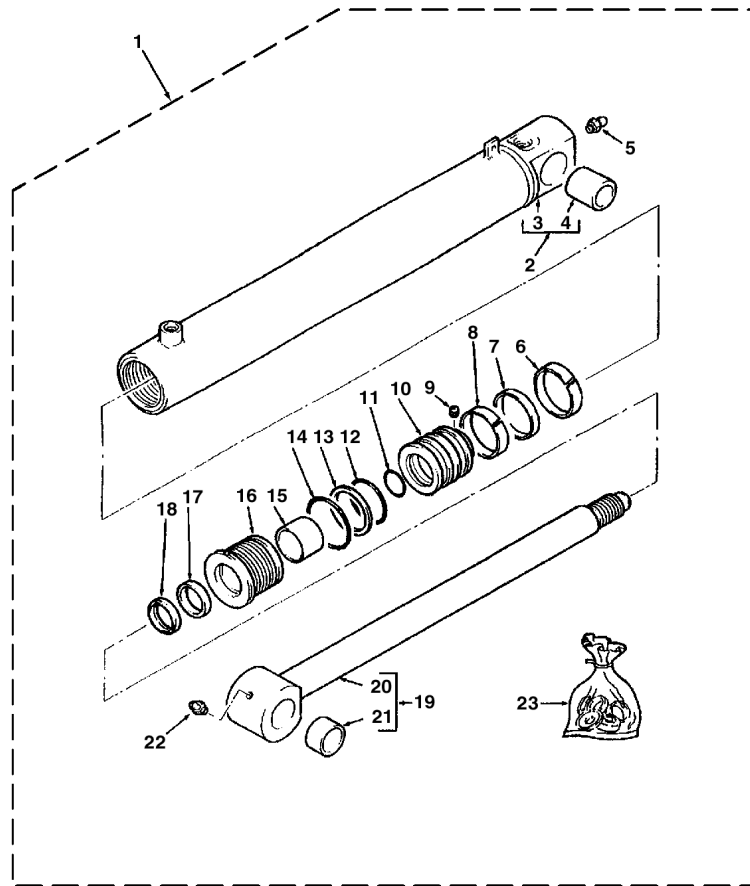

1	6109553M91		67004C01.1	1	2	Cylinder Assy	Ensemble de vérin	Gato, Conj.
2		1	(A)		1	Tube, Cylinder	Cylindre de vérin	Cilindro de gato
3		2	Ref. 2		1	Tube, Cylinder	Cylindre de vérin	Cilindro de gato
4	3623322M1	2			1	Bushing	Bague	Anillo
5	339608X1	1			1	Fitting, Grease	Graisneur	Engrasador
6	3485892M1	1	(B)		1	Ring, Sealing	Bague d'étanchéité	Anillo, Estanqueidad
7	3485245M91	1	(B)		1	Seal Assy	Ensemble de joint	Junta, Conj.
8	3485892M1	1	(B)		1	Ring, Sealing	Bague d'étanchéité	Anillo, Estanqueidad
9	3402928M1	1			1	Screw	Vis	Tornillo
10	3487180M1	1			1	Piston, Cylinder	Piston de vérin	Pistón de gato
11	359183X1	1	(B)		1	O-Ring	Joint torique	Junta de tipo O
12	359193X1	1	(B)		1	O-Ring	Joint torique	Junta de tipo O
13	1606735M1	1	(B)		1	Ring, Backup	Contre-joint	ContraJunta
14	3623641M1	1	(B)		1	O-Ring	Joint torique	Junta de tipo O
15	3443550M1	1	(B)		1	Ring	Anneau	Aro
16	5002159M1	1			1	Gland, Cylinder	Palier de vérin	Palier de gato
17	3403067M1	1	(B)		1	Ring, Sealing	Bague d'étanchéité	Anillo, Estanqueidad
18	1606058M1	1	(B)		1	Seal, Wiper	Joint de racleur	Junta raspador
19	3441920M91	1			1	Rod, Piston	Tige de vérin	Vástago cilindro
20		19	Ref. 19		1	Rod, Piston	Tige de vérin	Vástago cilindro
21	3623323M1	19			2	Bushing	Bague	Anillo
22	339608X1	1			1	Fitting, Grease	Graisneur	Engrasador
23	5001975M91		(C)		1	Kit, Seal	Pochette de joints	Juego de juntas

- A Part number to be advised
Référence pièce à demander
Indicar número de pieza
- C Contains items marked (B)
Comprend les pièces marquées (B)
Incluye las piezas marcadas (B)

- B Included in kit marked (C)
Inclus dans jeu marqué (C)
Incluido en juego marcado (C)



860 880 970 980
TX860B TX870B
TX970B

809 810 811 812 813 814 815 816 817 821 822 823 824 825 841 842 843 844 845
851 852 853 854 855 921 922 923 931 932

67004C02.1

6199042M3

1

Jan-06

Loader Hydraulics
Circuit Hydraulique de Chargeur
Circuito hidráulico cargadora

Lift Cylinder
Vérin de Levage
Gato de elevación

Standard Specification
 Qualité Inférieure
 Baja especificación

C-67005-01.1-A

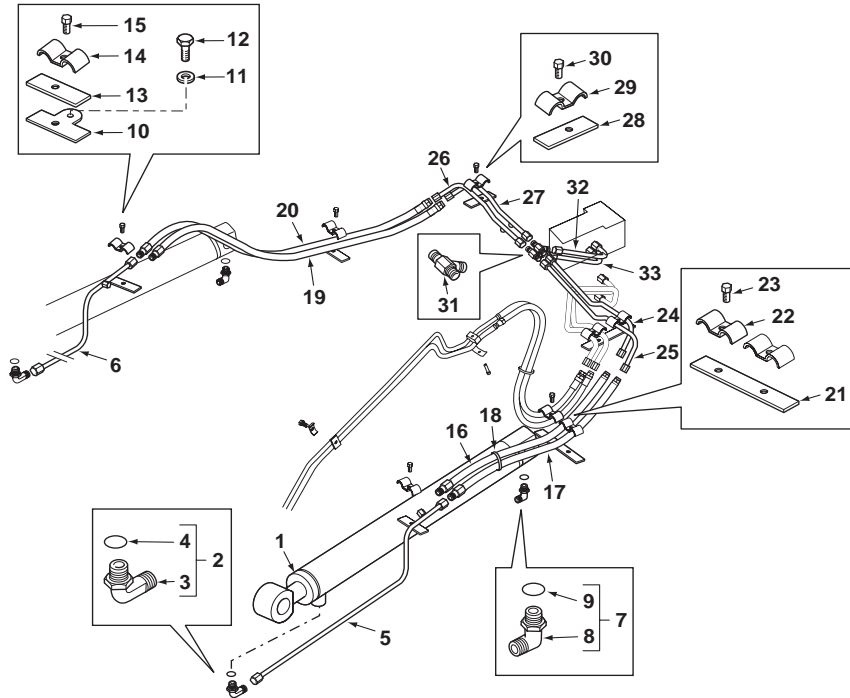

1	6109310M91		67005C02.1 1 Lift	2	Cylinder Assy	Ensemble de vérin	Gato, Conj.
2	835007M91			2	Elbow, 90°	Coude à 90°	Codo, 90°
3		2	Ref. 2	1	Elbow	Coude	Codo
4	835024M1	2		1	O-Ring	Joint torique	Junta de tipo O
5	6109544M91			1	Tube Assy	Tuyauterie	Conjunto de tubería
6	6109548M91			1	Tube Assy	Tuyauterie	Conjunto de tubería
7	835007M91			2	Elbow, 90°	Coude à 90°	Codo, 90°
8		7	Ref. 7	1	Elbow	Coude	Codo
9	835024M1	7		1	O-Ring	Joint torique	Junta de tipo O
10	6109791M91			2	Plate Assy	Ensemble de plaque	Placa, Conj.
11	339374X1	M8		2	Washer, Lock	Rondelle de blocage	Arandela de freno
12	339123X1	M8 x 20		2	Bolt	Boulon	Perno
13	6106109M1			2	Pad, Rubber	Plaque de caoutchouc	Placa, Caucho
14	6101228M1			2	Bracket, Clamp	Bride de fixation	Brida de fijación
15	339123X1	M8 x 20		2	Bolt	Boulon	Perno
16	6109919M91			1	Hose Assy	Ensemble de flexible	Flexible, Conj.
17	6109372M91			1	Hose Assy	Ensemble de flexible	Flexible, Conj.
18	1876229M1			2	Tie, Cable	Attache câble	Enlace de Cable
19	6109919M91			1	Hose Assy	Ensemble de flexible	Flexible, Conj.
20	6109372M91			1	Hose Assy	Ensemble de flexible	Flexible, Conj.
21	6101897M1			1	Pad, Rubber	Plaque de caoutchouc	Placa, Caucho
22	6101228M1			2	Bracket, Clamp	Bride de fixation	Brida de fijación
23	339124X1	M8 x 16		2	Screw	Vis	Tornillo
24	6109412M91			1	Tube Assy	Tuyauterie	Conjunto de tubería
25	6109414M91			1	Tube Assy	Tuyauterie	Conjunto de tubería
26	6109416M91			1	Tube Assy	Tuyauterie	Conjunto de tubería
27	6109418M91			1	Tube Assy	Tuyauterie	Conjunto de tubería
28	6106109M1			2	Pad, Rubber	Plaque de caoutchouc	Placa, Caucho
29	6101228M1			2	Bracket, Clamp	Bride de fixation	Brida de fijación
30	339124X1	M8 x 16		2	Screw	Vis	Tornillo
31	356561X1			2	Tee	Raccord en T	Te
32	6109428M91			1	Tube Assy	Tuyauterie	Conjunto de tubería
33	6109430M91			1	Tube Assy	Tuyauterie	Conjunto de tubería



820
TX760B

801 802 803 804 805 806 807 808 831 832 833 834

67005C01.1

6199042M3

1

Jan-06

Loader Hydraulics
Circuit Hydraulique de Chargeur
Circuito hidráulico cargadora

Lift Cylinder
Vérin de Levage
Gato de elevación

Standard Specification
 Qualité Inférieure
 Baja especificación

C-67005-02.1-B

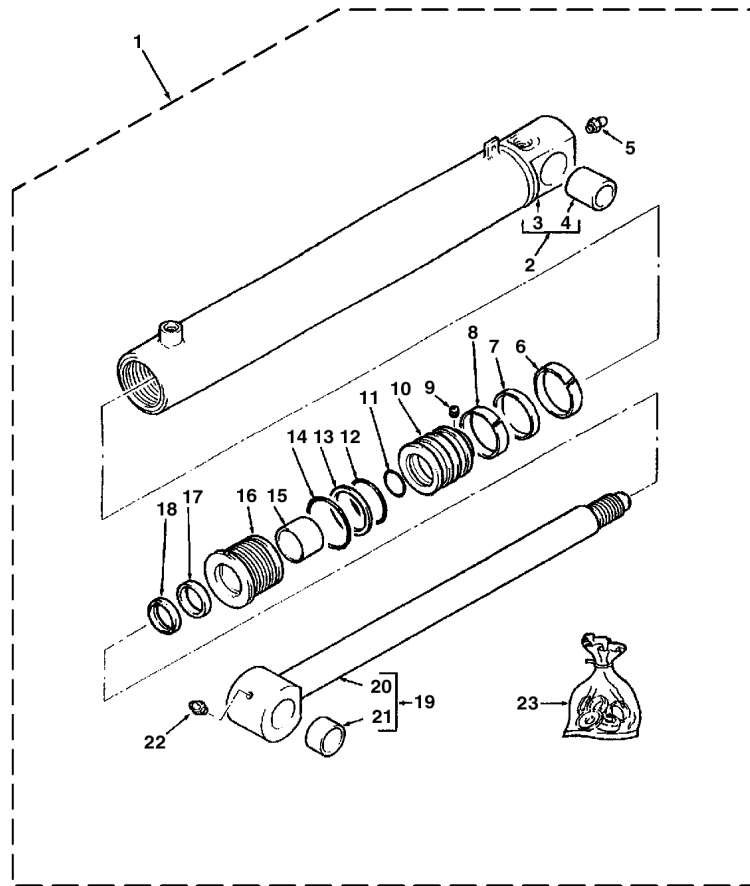

1	6109310M91		67005C01.1 1 Lift	2	Cylinder Assy	Ensemble de vérin	Gato, Conj.
2		1 (A)		1	Tube, Cylinder	Cylindre de vérin	Cilindro de gato
3		2	Ref. 2	1	Tube, Cylinder	Cylindre de vérin	Cilindro de gato
4	3623322M1	2		1	Bushing	Bague	Anillo
5	339608X1	1		1	Fitting, Grease	Graisser	Engrasador
6	3485889M1	1 (B)		1	Ring, Sealing	Bague d'étanchéité	Anillo, Estanqueidad
7	3485244M91	1 (B)		1	Seal Assy	Ensemble de joint	Junta, Conj.
8	3485889M1	1 (B)		1	Ring, Sealing	Bague d'étanchéité	Anillo, Estanqueidad
9	3402928M1	1		1	Screw	Vis	Tornillo
10	5001981M1	1		1	Piston, Cylinder	Piston de vérin	Pistón de gato
11	359183X1	1 (B)		1	O-Ring	Joint torique	Junta de tipo O
12	359191X1	1 (B)		1	O-Ring	Joint torique	Junta de tipo O
13	378543X1	1 (B)		1	Ring, Backup	Contre-joint	ContraJunta
14	3623640M1	1 (B)		1	O-Ring	Joint torique	Junta de tipo O
15	3443550M1	1 (B)		1	Ring	Anneau	Aro
16	5001980M1	1		1	Gland, Cylinder	Palier de vérin	Palier de gato
17	3403067M1	1 (B)		1	Ring, Sealing	Bague d'étanchéité	Anillo, Estanqueidad
18	1606058M1	1 (B)		1	Seal, Wiper	Joint de racléur	Junta raspador
19	3441920M91	1		1	Rod, Piston	Tige de vérin	Vástago cilindro
20		19	Ref. 19	1	Rod, Piston	Tige de vérin	Vástago cilindro
21	3623323M1	19		2	Bushing	Bague	Anillo
22	339608X1	1		1	Fitting, Grease	Graisser	Engrasador
23	5001982M91		(C)	1	Kit, Seal	Pochette de joints	Juego de juntas

- A Part number to be advised
 Référence pièce à demander
 Indicar número de pieza
- C Contains items marked (B)
 Comprend les pièces marquées (B)
 Incluye las piezas marcadas (B)

- B Included in kit marked (C)
 Inclus dans jeu marqué (C)
 Incluido en juego marcado (C)



820
 TX760B

801 802 803 804 805 806 807 808 831 832 833 834

67005C02.1

6199042M3

1

Jan-06

Loader Hydraulics
Circuit Hydraulique de Chargeur
Circuito hidráulico cargadora

Lift Cylinder
Vérin de Levage
Gato de elevación

High Specification
Qualité Supérieure
Alta especificación

C-67006-01.1-A

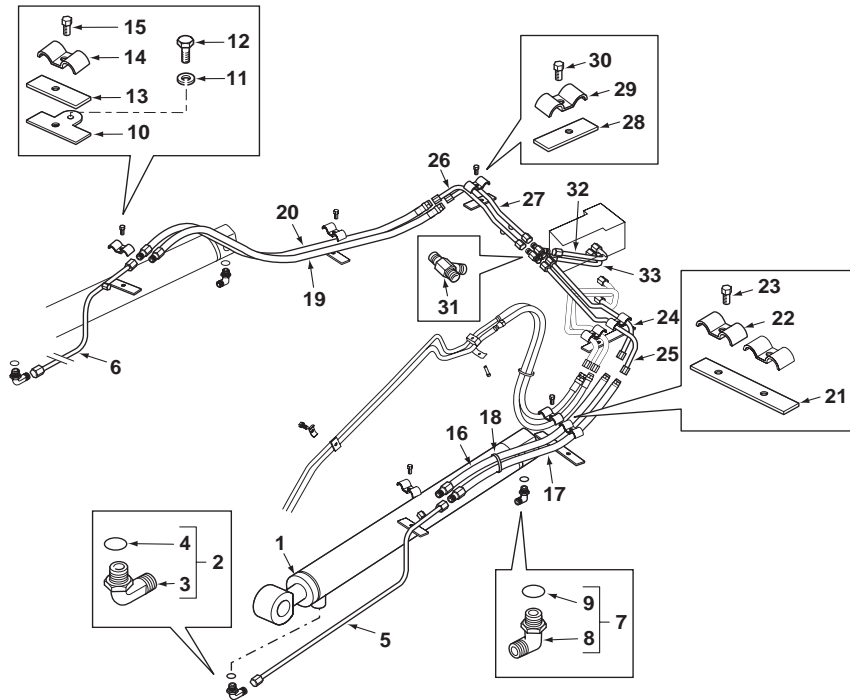

1	6109553M91		67006C02.1 1	2	Cylinder Assy	Ensemble de vérin	Gato, Conj.
2	835007M91			2	Elbow, 90°	Coude à 90°	Codo, 90°
3		2	Ref. 2	1	Elbow	Coude	Codo
4	835024M1	2		1	O-Ring	Joint torique	Junta de tipo O
5	6109544M91			1	Tube Assy	Tuyauterie	Conjunto de tubería
6	6109548M91			1	Tube Assy	Tuyauterie	Conjunto de tubería
7	835007M91			2	Elbow, 90°	Coude à 90°	Codo, 90°
8		7	Ref. 7	1	Elbow	Coude	Codo
9	835024M1	7		1	O-Ring	Joint torique	Junta de tipo O
10	6109791M91			2	Plate Assy	Ensemble de plaque	Placa, Conj.
11	339374X1	M8		2	Washer, Lock	Rondelle de blocage	Arandela de freno
12	339123X1	M8 x 20		2	Bolt	Boulon	Perno
13	6106109M1			2	Pad, Rubber	Plaque de caoutchouc	Placa, Caucho
14	6101228M1			2	Bracket, Clamp	Bride de fixation	Brida de fijación
15	339123X1	M8 x 20		2	Bolt	Boulon	Perno
16	6109919M91			1	Hose Assy	Ensemble de flexible	Flexible, Conj.
17	6109372M91			1	Hose Assy	Ensemble de flexible	Flexible, Conj.
18	1876229M1			2	Tie, Cable	Attache câble	Enlace de Cable
19	6109919M91			1	Hose Assy	Ensemble de flexible	Flexible, Conj.
20	6109372M91			1	Hose Assy	Ensemble de flexible	Flexible, Conj.
21	6101897M1			1	Pad, Rubber	Plaque de caoutchouc	Placa, Caucho
22	6101228M1			2	Bracket, Clamp	Bride de fixation	Brida de fijación
23	339124X1	M8 x 16		2	Screw	Vis	Tornillo
24	6109412M91			1	Tube Assy	Tuyauterie	Conjunto de tubería
25	6109414M91			1	Tube Assy	Tuyauterie	Conjunto de tubería
26	6109416M91			1	Tube Assy	Tuyauterie	Conjunto de tubería
27	6109418M91			1	Tube Assy	Tuyauterie	Conjunto de tubería
28	6106109M1			2	Pad, Rubber	Plaque de caoutchouc	Placa, Caucho
29	6101228M1			2	Bracket, Clamp	Bride de fixation	Brida de fijación
30	339124X1	M8 x 16		2	Screw	Vis	Tornillo
31	356561X1			2	Tee	Raccord en T	Te
32	6109428M91			1	Tube Assy	Tuyauterie	Conjunto de tubería
33	6109430M91			1	Tube Assy	Tuyauterie	Conjunto de tubería



860 880 970 980
 TX860B TX870B
 TX970B

813 814 815 816 817 821 822 823 824 825 841 842 843 844 845 851 852 853 854
 855 921 922 923 931 932

67006C01.1

6199042M3

1

Jan-06

Loader Hydraulics
Circuit Hydraulique de Chargeur
Circuito hidráulico cargadora

Lift Cylinder
Vérin de Levage
Gato de elevación

High Specification
Qualité Supérieure
Alta especificación

C-67006-02.1-B

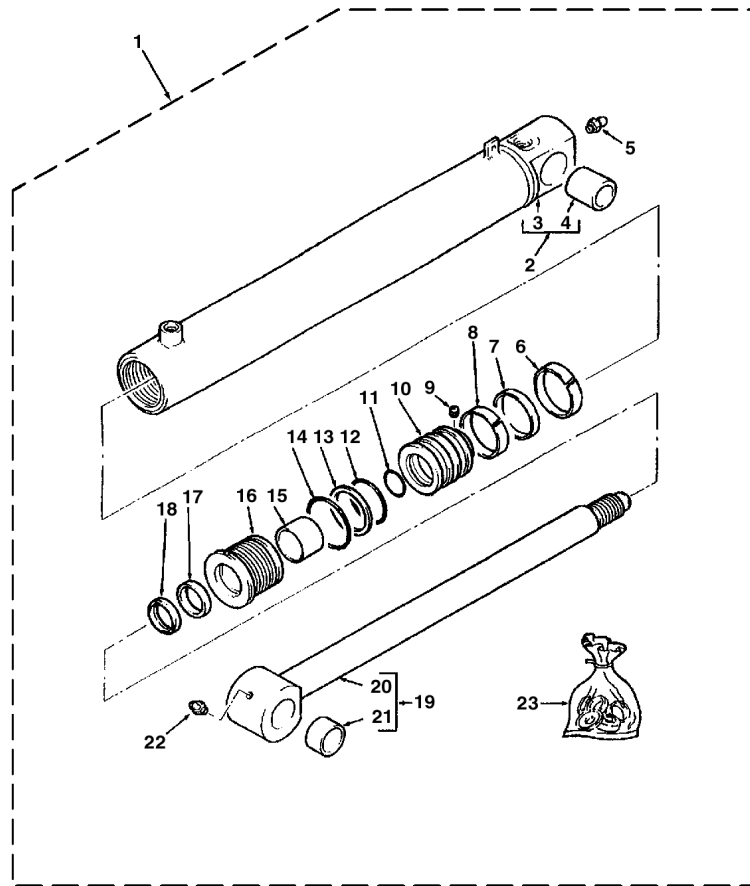

1	6109553M91		67006C01.1 1	2	Cylinder Assy	Ensemble de vérin	Gato, Conj.
2		1 (A)		1	Tube, Cylinder	Cylindre de vérin	Cilindro de gato
3		2	Ref. 2	1	Tube, Cylinder	Cylindre de vérin	Cilindro de gato
4	3623322M1	2		1	Bushing	Bague	Anillo
5	339608X1	1		1	Fitting, Grease	Graisseur	Engrasador
6	3485892M1	1 (B)		1	Ring, Sealing	Bague d'étanchéité	Anillo, Estanqueidad
7	3485245M91	1 (B)		1	Seal Assy	Ensemble de joint	Junta, Conj.
8	3485892M1	1 (B)		1	Ring, Sealing	Bague d'étanchéité	Anillo, Estanqueidad
9	3402928M1	1		1	Screw	Vis	Tornillo
10	3487180M1	1		1	Piston, Cylinder	Piston de vérin	Pistón de gato
11	359183X1	1 (B)		1	O-Ring	Joint torique	Junta de tipo O
12	359193X1	1 (B)		1	O-Ring	Joint torique	Junta de tipo O
13	1606735M1	1 (B)		1	Ring, Backup	Contre-joint	ContraJunta
14	3623641M1	1 (B)		1	O-Ring	Joint torique	Junta de tipo O
15	3443550M1	1 (B)		1	Ring	Anneau	Aro
16	5002159M1	1		1	Gland, Cylinder	Palier de vérin	Palier de gato
17	3403067M1	1 (B)		1	Ring, Sealing	Bague d'étanchéité	Anillo, Estanqueidad
18	1606058M1	1 (B)		1	Seal, Wiper	Joint de racleur	Junta raspador
19	3441920M91	1		1	Rod, Piston	Tige de vérin	Vástago cilindro
20		19	Ref. 19	1	Rod, Piston	Tige de vérin	Vástago cilindro
21	3623323M1	19		2	Bushing	Bague	Anillo
22	339608X1	1		1	Fitting, Grease	Graisseur	Engrasador
23	5001975M91		(C)	1	Kit, Seal	Pochette de joints	Juego de juntas

- A Part number to be advised
Référence pièce à demander
Indicar número de pieza
- C Contains items marked (B)
Comprend les pièces marquées (B)
Incluye las piezas marcadas (B)

- B Included in kit marked (C)
Inclus dans jeu marqué (C)
Incluido en juego marcado (C)



860 880 970 980
TX860B TX870B
TX970B

813 814 815 816 817 821 822 823 824 825 841 842 843 844 845 851 852 853 854
855 921 922 923 931 932

67006C02.1

6199042M3

1

Jan-06

Loader Hydraulics
Circuit Hydraulique de Chargeur
Circuito hidráulico cargadora

Lift Cylinder
Vérin de Levage
Gato de elevación

Standard Specification
 Qualité Inférieure
 Baja especificación

7 in 1 Bucket
 7 in 1 Bucket
 7 in 1 Bucket

C-67007-01.1-A

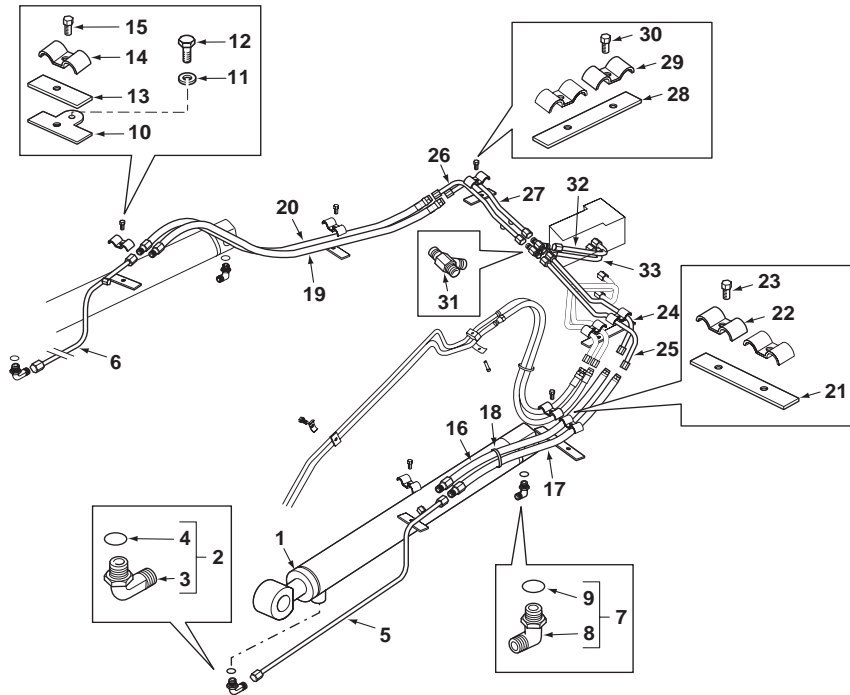

1	6109310M91		67007C02.1 1 Lift	2	Cylinder Assy	Ensemble de vérin	Gato, Conj.
2	835007M91			2	Elbow, 90°	Coude à 90°	Codo, 90°
3		2	Ref. 2	1	Elbow	Coude	Codo
4	835024M1	2		1	O-Ring	Joint torique	Junta de tipo O
5	6109544M91			1	Tube Assy	Tuyauterie	Conjunto de tubería
6	6109548M91			1	Tube Assy	Tuyauterie	Conjunto de tubería
7	835007M91			2	Elbow, 90°	Coude à 90°	Codo, 90°
8		7	Ref. 7	1	Elbow	Coude	Codo
9	835024M1	7		1	O-Ring	Joint torique	Junta de tipo O
10	6109791M91			2	Plate Assy	Ensemble de plaque	Placa, Conj.
11	339374X1	M8		2	Washer, Lock	Rondelle de blocage	Arandela de freno
12	339123X1	M8 x 20		2	Bolt	Boulon	Perno
13	6106109M1			2	Pad, Rubber	Plaque de caoutchouc	Placa, Caucho
14	6101228M1			2	Bracket, Clamp	Bride de fixation	Brida de fijación
15	339123X1	M8 x 20		2	Bolt	Boulon	Perno
16	6109919M91			1	Hose Assy	Ensemble de flexible	Flexible, Conj.
17	6109372M91			1	Hose Assy	Ensemble de flexible	Flexible, Conj.
18	1876229M1			2	Tie, Cable	Attache câble	Enlace de Cable
19	6109919M91			1	Hose Assy	Ensemble de flexible	Flexible, Conj.
20	6109372M91			1	Hose Assy	Ensemble de flexible	Flexible, Conj.
21	6101897M1			1	Pad, Rubber	Plaque de caoutchouc	Placa, Caucho
22	6101228M1			2	Bracket, Clamp	Bride de fixation	Brida de fijación
23	339124X1	M8 x 16		2	Screw	Vis	Tornillo
24	6109412M91			1	Tube Assy	Tuyauterie	Conjunto de tubería
25	6109414M91			1	Tube Assy	Tuyauterie	Conjunto de tubería
26	6109416M91			1	Tube Assy	Tuyauterie	Conjunto de tubería
27	6109418M91			1	Tube Assy	Tuyauterie	Conjunto de tubería
28	6101897M1			2	Pad, Rubber	Plaque de caoutchouc	Placa, Caucho
29	6101228M1			4	Bracket, Clamp	Bride de fixation	Brida de fijación
30	339124X1	M8 x 16		4	Screw	Vis	Tornillo
31	356561X1			2	Tee	Raccord en T	Te
32	6109428M91			1	Tube Assy	Tuyauterie	Conjunto de tubería
33	6109430M91			1	Tube Assy	Tuyauterie	Conjunto de tubería



820
TX760B

801 802 803 804 805 806 807 808 831 832 833 834

67007C01.1

6199042M3

1

Jan-06

Loader Hydraulics
Circuit Hydraulique de Chargeur
Circuito hidráulico cargadora

Lift Cylinder
Vérin de Levage
Gato de elevación

Standard Specification
 Qualité Inférieure
 Baja especificación

C-67007-02.1-B

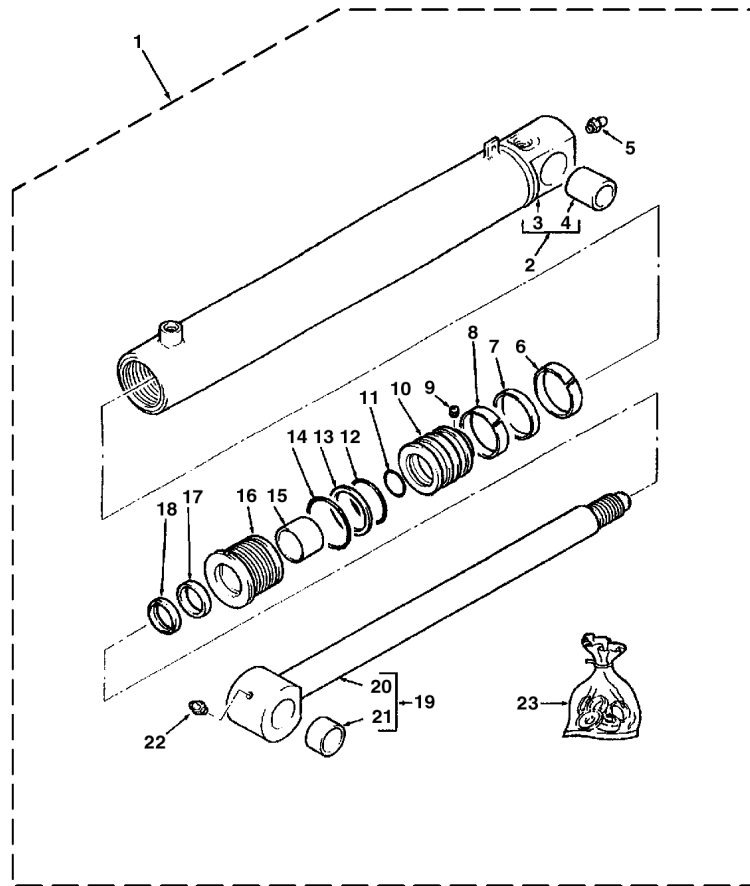

1	6109310M91		67007C01.1 1 Lift	2	Cylinder Assy	Ensemble de vérin	Gato, Conj.
2		1 (A)		1	Tube, Cylinder	Cylindre de vérin	Cilindro de gato
3		2	Ref. 2	1	Tube, Cylinder	Cylindre de vérin	Cilindro de gato
4	3623322M1	2		1	Bushing	Bague	Anillo
5	339608X1	1		1	Fitting, Grease	Graisneur	Engrasador
6	3485889M1	1 (B)		1	Ring, Sealing	Bague d'étanchéité	Anillo, Estanqueidad
7	3485244M91	1 (B)		1	Seal Assy	Ensemble de joint	Junta, Conj.
8	3485889M1	1 (B)		1	Ring, Sealing	Bague d'étanchéité	Anillo, Estanqueidad
9	3402928M1	1		1	Screw	Vis	Tornillo
10	5001981M1	1		1	Piston, Cylinder	Piston de vérin	Pistón de gato
11	359183X1	1 (B)		1	O-Ring	Joint torique	Junta de tipo O
12	359191X1	1 (B)		1	O-Ring	Joint torique	Junta de tipo O
13	378543X1	1 (B)		1	Ring, Backup	Contre-joint	ContraJunta
14	3623640M1	1 (B)		1	O-Ring	Joint torique	Junta de tipo O
15	3443550M1	1 (B)		1	Ring	Anneau	Aro
16	5001980M1	1		1	Gland, Cylinder	Palier de vérin	Palier de gato
17	3403067M1	1 (B)		1	Ring, Sealing	Bague d'étanchéité	Anillo, Estanqueidad
18	1606058M1	1 (B)		1	Seal, Wiper	Joint de racléur	Junta raspador
19	3441920M91	1		1	Rod, Piston	Tige de vérin	Vástago cilindro
20		19	Ref. 19	1	Rod, Piston	Tige de vérin	Vástago cilindro
21	3623323M1	19		2	Bushing	Bague	Anillo
22	339608X1	1		1	Fitting, Grease	Graisneur	Engrasador
23	5001982M91	(C)		1	Kit, Seal	Pochette de joints	Juego de juntas

- A Part number to be advised
 Référence pièce à demander
 Indicar número de pieza
- C Contains items marked (B)
 Comprend les pièces marquées (B)
 Incluye las piezas marcadas (B)

- B Included in kit marked (C)
 Inclus dans jeu marqué (C)
 Incluido en juego marcado (C)



820
 TX760B

801 802 803 804 805 806 807 808 831 832 833 834

67007C02.1

6199042M3

1

Jan-06

Loader Hydraulics
Circuit Hydraulique de Chargeur
Circuito hidráulico cargadora

Lift Cylinder
Vérin de Levage
Gato de elevación

High Specification
 Qualité Supérieure
 Alta especificación

7 in 1 Bucket
 7 in 1 Bucket
 7 in 1 Bucket

C-67008-01.1-A

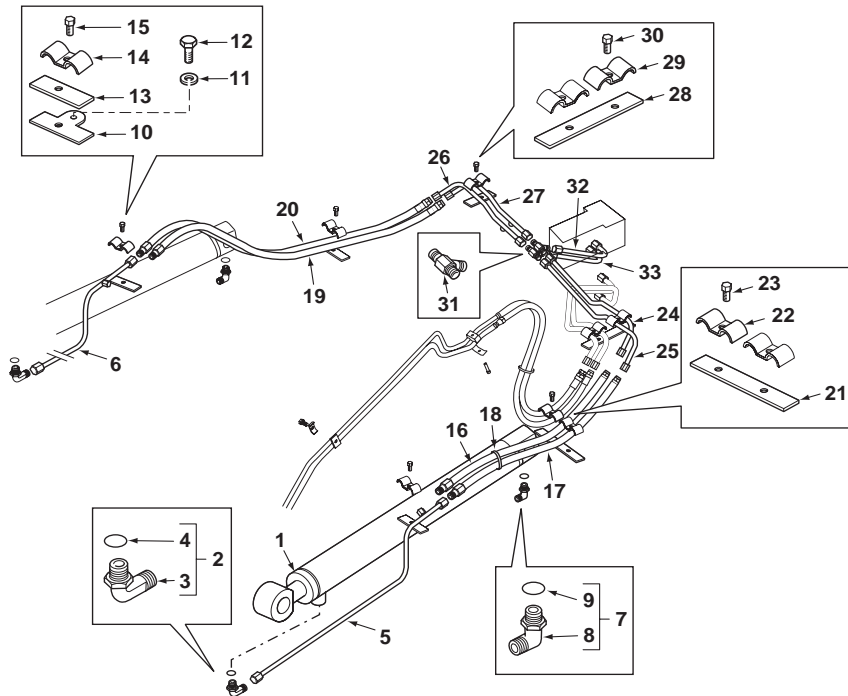

1	6109553M91	67008C02.1 1	2	Cylinder Assy	Ensemble de vérin	Gato, Conj.
2	835007M91		2	Elbow, 90°	Coude à 90°	Codo, 90°
3		2 Ref. 2	1	Elbow	Coude	Codo
4	835024M1	2	1	O-Ring	Joint torique	Junta de tipo O
5	6109544M91		1	Tube Assy	Tuyauterie	Conjunto de tubería
6	6109548M91		1	Tube Assy	Tuyauterie	Conjunto de tubería
7	835007M91		2	Elbow, 90°	Coude à 90°	Codo, 90°
8		7 Ref. 7	1	Elbow	Coude	Codo
9	835024M1	7	1	O-Ring	Joint torique	Junta de tipo O
10	6109791M91		2	Plate Assy	Ensemble de plaque	Placa, Conj.
11	339374X1	M8	2	Washer, Lock	Rondelle de blocage	Arandela de freno
12	339123X1	M8 x 20	2	Bolt	Boulon	Perno
13	6106109M1		2	Pad, Rubber	Plaque de caoutchouc	Placa, Caucho
14	6101228M1		2	Bracket, Clamp	Bride de fixation	Brida de fijación
15	339123X1	M8 x 20	2	Bolt	Boulon	Perno
16	6109919M91		1	Hose Assy	Ensemble de flexible	Flexible, Conj.
17	6109372M91		1	Hose Assy	Ensemble de flexible	Flexible, Conj.
18	1876229M1		2	Tie, Cable	Attache câble	Enlace de Cable
19	6109919M91		1	Hose Assy	Ensemble de flexible	Flexible, Conj.
20	6109372M91		1	Hose Assy	Ensemble de flexible	Flexible, Conj.
21	6101897M1		1	Pad, Rubber	Plaque de caoutchouc	Placa, Caucho
22	6101228M1		2	Bracket, Clamp	Bride de fixation	Brida de fijación
23	339124X1	M8 x 16	2	Screw	Vis	Tornillo
24	6109412M91		1	Tube Assy	Tuyauterie	Conjunto de tubería
25	6109414M91		1	Tube Assy	Tuyauterie	Conjunto de tubería
26	6109416M91		1	Tube Assy	Tuyauterie	Conjunto de tubería
27	6109418M91		1	Tube Assy	Tuyauterie	Conjunto de tubería
28	6101897M1		2	Pad, Rubber	Plaque de caoutchouc	Placa, Caucho
29	6101228M1		4	Bracket, Clamp	Bride de fixation	Brida de fijación
30	339124X1	M8 x 16	4	Screw	Vis	Tornillo
31	356561X1		2	Tee	Raccord en T	Te
32	6109428M91		1	Tube Assy	Tuyauterie	Conjunto de tubería
33	6109430M91		1	Tube Assy	Tuyauterie	Conjunto de tubería



860 880 970 980
 TX860B TX870B
 TX970B

813 814 815 816 817 821 822 823 824 825 841 842 843 844 845 851 852 853 854
 855 921 922 923 931 932

67008C01.1

6199042M3

1

Jan-06

Loader Hydraulics
Circuit Hydraulique de Chargeur
Circuito hidráulico cargadora

Lift Cylinder
Vérin de Levage
Gato de elevación

High Specification
Qualité Supérieure
Alta especificación

C-67008-02.1-B

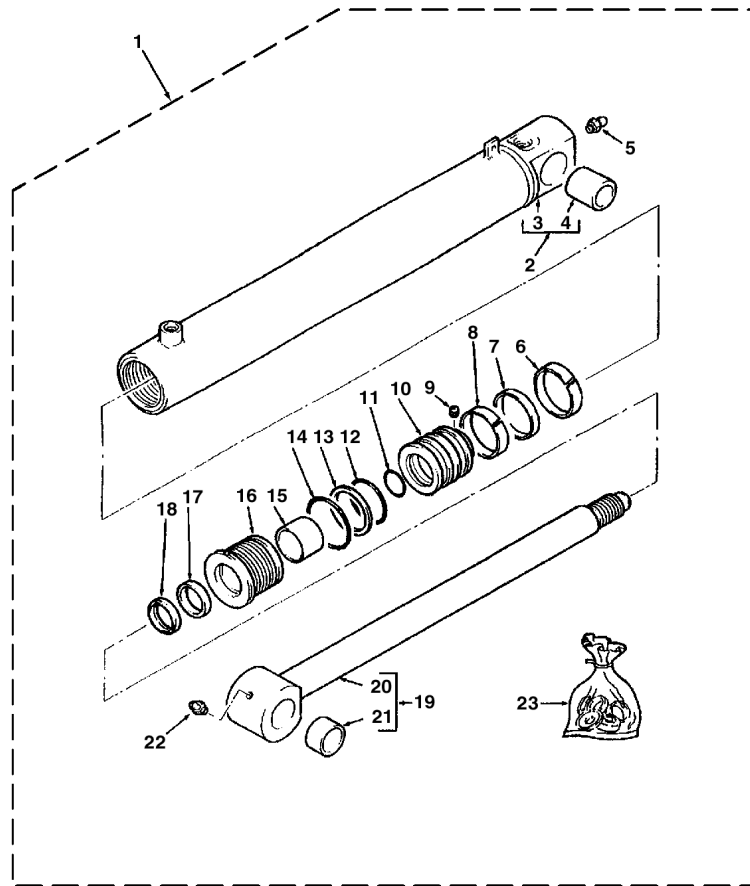

1	6109553M91		67008C01.1 1	2	Cylinder Assy	Ensemble de vérin	Gato, Conj.
2		1	(A)	1	Tube, Cylinder	Cylindre de vérin	Cilindro de gato
3		2	Ref. 2	1	Tube, Cylinder	Cylindre de vérin	Cilindro de gato
4	3623322M1	2		1	Bushing	Bague	Anillo
5	339608X1	1		1	Fitting, Grease	Graisneur	Engrasador
6	3485892M1	1	(B)	1	Ring, Sealing	Bague d'étanchéité	Anillo, Estanqueidad
7	3485245M91	1	(B)	1	Seal Assy	Ensemble de joint	Junta, Conj.
8	3485892M1	1	(B)	1	Ring, Sealing	Bague d'étanchéité	Anillo, Estanqueidad
9	3402928M1	1		1	Screw	Vis	Tornillo
10	3487180M1	1		1	Piston, Cylinder	Piston de vérin	Pistón de gato
11	359183X1	1	(B)	1	O-Ring	Joint torique	Junta de tipo O
12	359193X1	1	(B)	1	O-Ring	Joint torique	Junta de tipo O
13	1606735M1	1	(B)	1	Ring, Backup	Contre-joint	ContraJunta
14	3623641M1	1	(B)	1	O-Ring	Joint torique	Junta de tipo O
15	3443550M1	1	(B)	1	Ring	Anneau	Aro
16	5002159M1	1		1	Gland, Cylinder	Palier de vérin	Palier de gato
17	3403067M1	1	(B)	1	Ring, Sealing	Bague d'étanchéité	Anillo, Estanqueidad
18	1606058M1	1	(B)	1	Seal, Wiper	Joint de racleur	Junta raspador
19	3441920M91	1		1	Rod, Piston	Tige de vérin	Vástago cilindro
20		19	Ref. 19	1	Rod, Piston	Tige de vérin	Vástago cilindro
21	3623323M1	19		2	Bushing	Bague	Anillo
22	339608X1	1		1	Fitting, Grease	Graisneur	Engrasador
23	5001975M91		(C)	1	Kit, Seal	Pochette de joints	Juego de juntas

- A Part number to be advised
Référence pièce à demander
Indicar número de pieza
- C Contains items marked (B)
Comprend les pièces marquées (B)
Incluye las piezas marcadas (B)

- B Included in kit marked (C)
Inclus dans jeu marqué (C)
Incluido en juego marcado (C)



860 880 970 980
TX860B TX870B
TX970B

813 814 815 816 817 821 822 823 824 825 841 842 843 844 845 851 852 853 854
855 921 922 923 931 932

67008C02.1

6199042M3

1

Jan-06

Loader Hydraulics
Circuit Hydraulique de Chargeur
Circuito hidráulico cargadora

Lift Cylinder
Vérin de Levage
Gato de elevación

Standard Specification
 Qualité Inférieure
 Baja especificación

C-67009-01.1-A

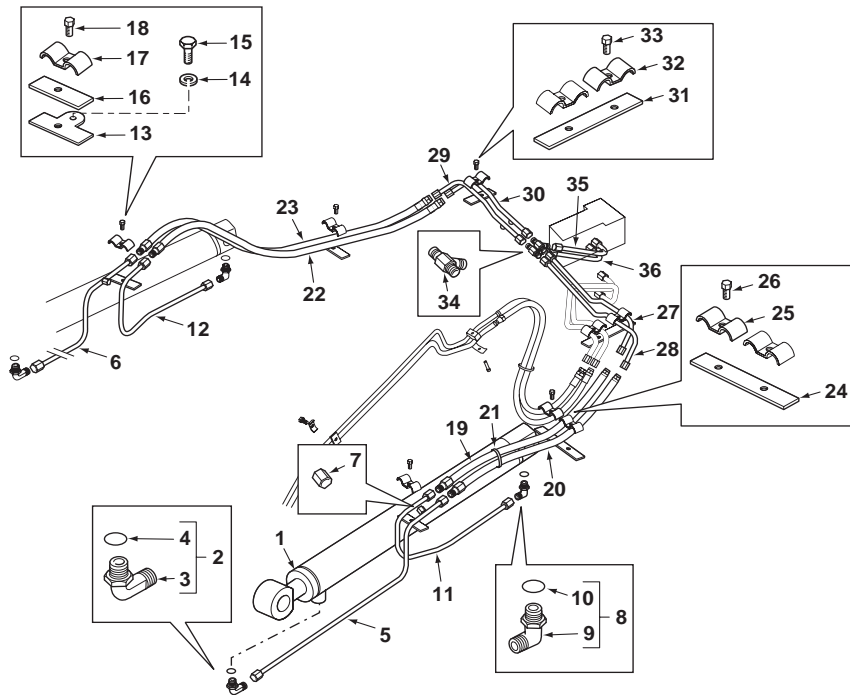

1	6109310M91		67009C02.1 1 Lift	2	Cylinder Assy	Ensemble de vérin	Gato, Conj.
2	835007M91			2	Elbow, 90°	Coude à 90°	Codo, 90°
3		2	Ref. 2	1	Elbow	Coude	Codo
4	835024M1	2		1	O-Ring	Joint torique	Junta de tipo O
5	6109544M91			1	Tube Assy	Tuyauterie	Conjunto de tubería
6	6109548M91			1	Tube Assy	Tuyauterie	Conjunto de tubería
7	356579X1			2	Cap	Chapeau	Sombbrero
8	835007M91			2	Elbow, 90°	Coude à 90°	Codo, 90°
9		8	Ref. 8	1	Elbow	Coude	Codo
10	835024M1	8		1	O-Ring	Joint torique	Junta de tipo O
11	6109546M91			1	Tube Assy	Tuyauterie	Conjunto de tubería
12	6109550M91			1	Tube Assy	Tuyauterie	Conjunto de tubería
13	6109791M91			2	Plate Assy	Ensemble de plaque	Placa, Conj.
14	339374X1	M8		2	Washer, Lock	Rondelle de blocage	Arandela de freno
15	339123X1	M8 x 20		2	Bolt	Boulon	Perno
16	6106109M1			2	Pad, Rubber	Plaque de caoutchouc	Placa, Caucho
17	6101228M1			2	Bracket, Clamp	Bride de fixation	Brida de fijación
18	339123X1	M8 x 20		2	Bolt	Boulon	Perno
19	6109919M91			1	Hose Assy	Ensemble de flexible	Flexible, Conj.
20	6109372M91			1	Hose Assy	Ensemble de flexible	Flexible, Conj.
21	1876229M1			2	Tie, Cable	Attache câble	Enlace de Cable
22	6109919M91			1	Hose Assy	Ensemble de flexible	Flexible, Conj.
23	6109372M91			1	Hose Assy	Ensemble de flexible	Flexible, Conj.
24	6101897M1			1	Pad, Rubber	Plaque de caoutchouc	Placa, Caucho
25	6101228M1			2	Bracket, Clamp	Bride de fixation	Brida de fijación
26	339124X1	M8 x 16		2	Screw	Vis	Tornillo
27	6109412M91			1	Tube Assy	Tuyauterie	Conjunto de tubería
28	6109414M91			1	Tube Assy	Tuyauterie	Conjunto de tubería
29	6109416M91			1	Tube Assy	Tuyauterie	Conjunto de tubería
30	6109418M91			1	Tube Assy	Tuyauterie	Conjunto de tubería
31	6101897M1			2	Pad, Rubber	Plaque de caoutchouc	Placa, Caucho
32	6101228M1			4	Bracket, Clamp	Bride de fixation	Brida de fijación
33	339124X1	M8 x 16		4	Screw	Vis	Tornillo
34	356561X1			2	Tee	Raccord en T	Te
35	6109428M91			1	Tube Assy	Tuyauterie	Conjunto de tubería
36	6109430M91			1	Tube Assy	Tuyauterie	Conjunto de tubería



820
TX760B

801 802 803 804 805 806 807 808 831 832 833 834

67009C01.1

6199042M3

1

Jan-06

Loader Hydraulics
Circuit Hydraulique de Chargeur
Circuito hidráulico cargadora

Lift Cylinder
Vérin de Levage
Gato de elevación

Standard Specification
 Qualité Inférieure
 Baja especificación

C-67009-02.1-B

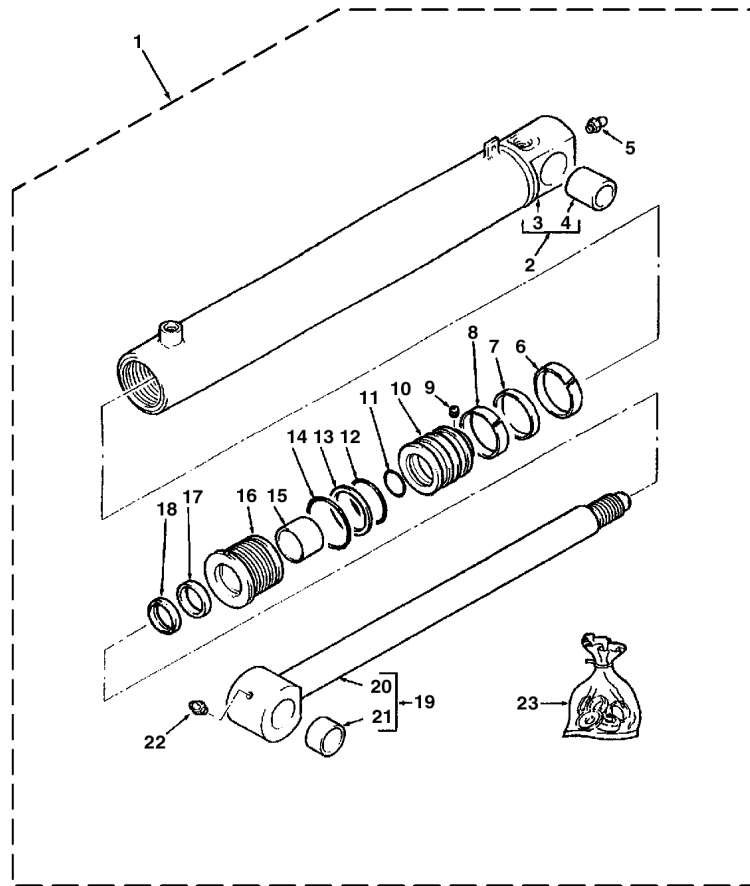

1	6109310M91		67009C01.1 1 Lift	2	Cylinder Assy	Ensemble de vérin	Gato, Conj.
2		1 (A)		1	Tube, Cylinder	Cylindre de vérin	Cilindro de gato
3		2	Ref. 2	1	Tube, Cylinder	Cylindre de vérin	Cilindro de gato
4	3623322M1	2		1	Bushing	Bague	Anillo
5	339608X1	1		1	Fitting, Grease	Graisneur	Engrasador
6	3485889M1	1 (B)		1	Ring, Sealing	Bague d'étanchéité	Anillo, Estanqueidad
7	3485244M91	1 (B)		1	Seal Assy	Ensemble de joint	Junta, Conj.
8	3485889M1	1 (B)		1	Ring, Sealing	Bague d'étanchéité	Anillo, Estanqueidad
9	3402928M1	1		1	Screw	Vis	Tornillo
10	5001981M1	1		1	Piston, Cylinder	Piston de vérin	Pistón de gato
11	359183X1	1 (B)		1	O-Ring	Joint torique	Junta de tipo O
12	359191X1	1 (B)		1	O-Ring	Joint torique	Junta de tipo O
13	378543X1	1 (B)		1	Ring, Backup	Contre-joint	ContraJunta
14	3623640M1	1 (B)		1	O-Ring	Joint torique	Junta de tipo O
15	3443550M1	1 (B)		1	Ring	Anneau	Aro
16	5001980M1	1		1	Gland, Cylinder	Palier de vérin	Palier de gato
17	3403067M1	1 (B)		1	Ring, Sealing	Bague d'étanchéité	Anillo, Estanqueidad
18	1606058M1	1 (B)		1	Seal, Wiper	Joint de racleur	Junta raspador
19	3441920M91	1		1	Rod, Piston	Tige de vérin	Vástago cilindro
20		19	Ref. 19	1	Rod, Piston	Tige de vérin	Vástago cilindro
21	3623323M1	19		2	Bushing	Bague	Anillo
22	339608X1	1		1	Fitting, Grease	Graisneur	Engrasador
23	5001982M91		(C)	1	Kit, Seal	Pochette de joints	Juego de juntas

- A Part number to be advised
 Référence pièce à demander
 Indicar número de pieza
- C Contains items marked (B)
 Comprend les pièces marquées (B)
 Incluye las piezas marcadas (B)

- B Included in kit marked (C)
 Inclus dans jeu marqué (C)
 Incluido en juego marcado (C)



820
 TX760B

801 802 803 804 805 806 807 808 831 832 833 834

67009C02.1

6199042M3

1

Jan-06

Loader Hydraulics
Circuit Hydraulique de Chargeur
Circuito hidráulico cargadora

Lift Cylinder
Vérin de Levage
Gato de elevación

High Specification
Qualité Supérieure
Alta especificación

C-67010-01.1-A

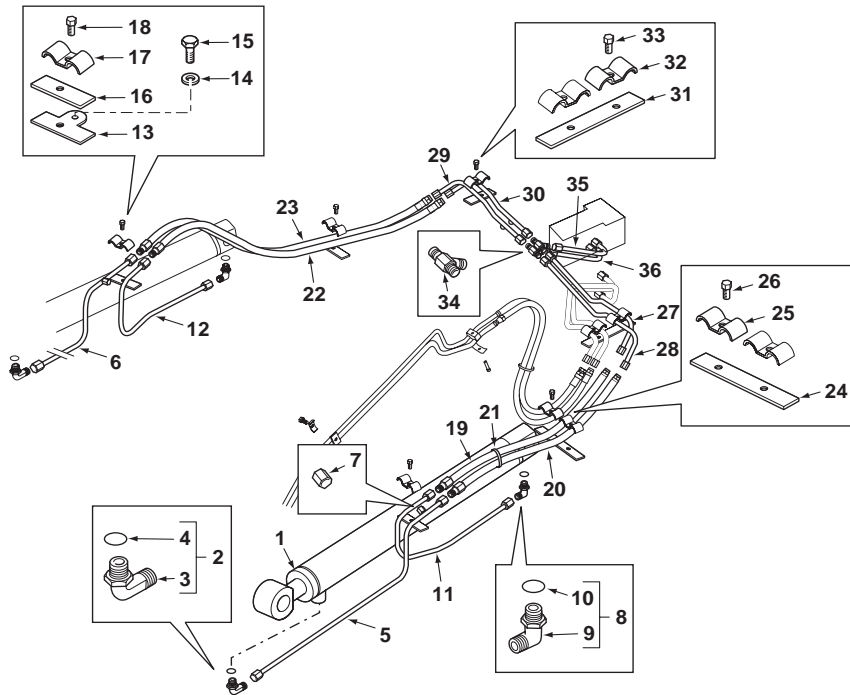

1	6109553M91	67010C02.1	1	2	Cylinder Assy	Ensemble de vérin	Gato, Conj.
2	835007M91			2	Elbow, 90°	Coude à 90°	Codo, 90°
3		2	Ref. 2	1	Elbow	Coude	Codo
4	835024M1	2		1	O-Ring	Joint torique	Junta de tipo O
5	6109544M91			1	Tube Assy	Tuyauterie	Conjunto de tubería
6	6109548M91			1	Tube Assy	Tuyauterie	Conjunto de tubería
7	356579X1			2	Cap	Chapeau	Sombbrero
8	835007M91			2	Elbow, 90°	Coude à 90°	Codo, 90°
9		8	Ref. 8	1	Elbow	Coude	Codo
10	835024M1	8		1	O-Ring	Joint torique	Junta de tipo O
11	6109546M91			1	Tube Assy	Tuyauterie	Conjunto de tubería
12	6109550M91			1	Tube Assy	Tuyauterie	Conjunto de tubería
13	6109791M91			2	Plate Assy	Ensemble de plaque	Placa, Conj.
14	339374X1	M8		2	Washer, Lock	Rondelle de blocage	Arandela de freno
15	339123X1	M8 x 20		2	Bolt	Boulon	Perno
16	6106109M1			2	Pad, Rubber	Plaque de caoutchouc	Placa, Caucho
17	6101228M1			2	Bracket, Clamp	Bride de fixation	Brida de fijación
18	339123X1	M8 x 20		2	Bolt	Boulon	Perno
19	6109919M91			1	Hose Assy	Ensemble de flexible	Flexible, Conj.
20	6109372M91			1	Hose Assy	Ensemble de flexible	Flexible, Conj.
21	1876229M1			2	Tie, Cable	Attache câble	Enlace de Cable
22	6109919M91			1	Hose Assy	Ensemble de flexible	Flexible, Conj.
23	6109372M91			1	Hose Assy	Ensemble de flexible	Flexible, Conj.
24	6101897M1			1	Pad, Rubber	Plaque de caoutchouc	Placa, Caucho
25	6101228M1			2	Bracket, Clamp	Bride de fixation	Brida de fijación
26	339124X1	M8 x 16		2	Screw	Vis	Tornillo
27	6109412M91			1	Tube Assy	Tuyauterie	Conjunto de tubería
28	6109414M91			1	Tube Assy	Tuyauterie	Conjunto de tubería
29	6109416M91			1	Tube Assy	Tuyauterie	Conjunto de tubería
30	6109418M91			1	Tube Assy	Tuyauterie	Conjunto de tubería
31	6101897M1			2	Pad, Rubber	Plaque de caoutchouc	Placa, Caucho
32	6101228M1			4	Bracket, Clamp	Bride de fixation	Brida de fijación
33	339124X1	M8 x 16		4	Screw	Vis	Tornillo
34	356561X1			2	Tee	Raccord en T	Te
35	6109428M91			1	Tube Assy	Tuyauterie	Conjunto de tubería
36	6109430M91			1	Tube Assy	Tuyauterie	Conjunto de tubería



860 880 970 980
 TX860B TX870B
 TX970B

809 810 811 812 813 814 815 816 817 821 822 823 824 825 841 842 843 844 845
 851 852 853 854 855 921 922 923 931 932

67010C01.1

6199042M3

1

Jan-06

Loader Hydraulics
Circuit Hydraulique de Chargeur
Circuito hidráulico cargadora

Lift Cylinder
Vérin de Levage
Gato de elevación

High Specification
Qualité Supérieure
Alta especificación

C-67010-02.1-B

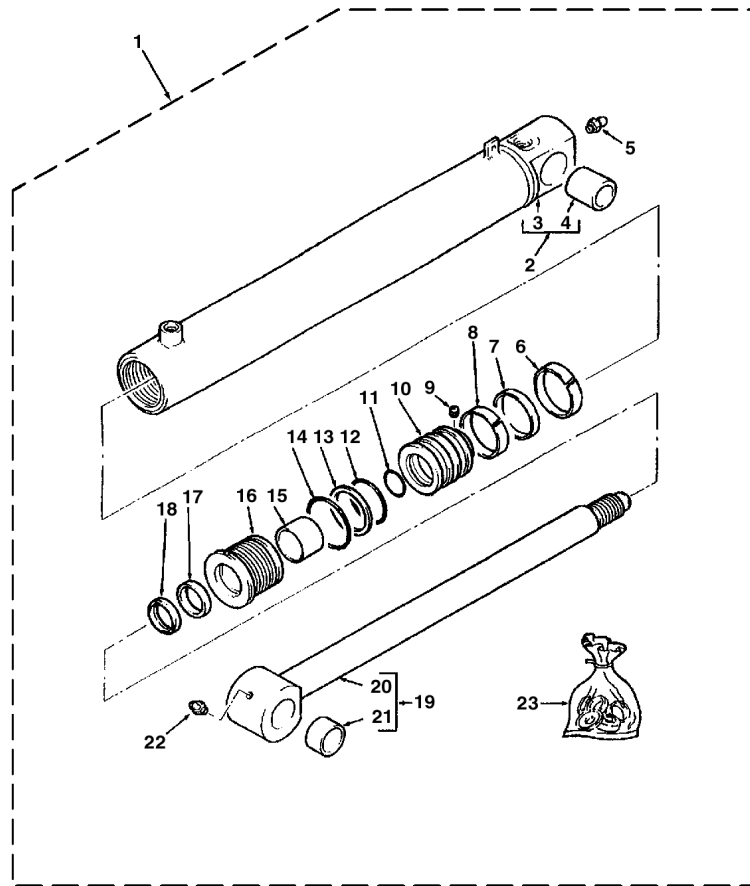

1	6109553M91		67010C01.1	1	2	Cylinder Assy	Ensemble de vérin	Gato, Conj.
2		1	(A)		1	Tube, Cylinder	Cylindre de vérin	Cilindro de gato
3		2	Ref. 2		1	Tube, Cylinder	Cylindre de vérin	Cilindro de gato
4	3623322M1	2			1	Bushing	Bague	Anillo
5	339608X1	1			1	Fitting, Grease	Graisneur	Engrasador
6	3485892M1	1	(B)		1	Ring, Sealing	Bague d'étanchéité	Anillo, Estanqueidad
7	3485245M91	1	(B)		1	Seal Assy	Ensemble de joint	Junta, Conj.
8	3485892M1	1	(B)		1	Ring, Sealing	Bague d'étanchéité	Anillo, Estanqueidad
9	3402928M1	1			1	Screw	Vis	Tornillo
10	3487180M1	1			1	Piston, Cylinder	Piston de vérin	Pistón de gato
11	359183X1	1	(B)		1	O-Ring	Joint torique	Junta de tipo O
12	359193X1	1	(B)		1	O-Ring	Joint torique	Junta de tipo O
13	1606735M1	1	(B)		1	Ring, Backup	Contre-joint	ContraJunta
14	3623641M1	1	(B)		1	O-Ring	Joint torique	Junta de tipo O
15	3443550M1	1	(B)		1	Ring	Anneau	Aro
16	5002159M1	1			1	Gland, Cylinder	Palier de vérin	Palier de gato
17	3403067M1	1	(B)		1	Ring, Sealing	Bague d'étanchéité	Anillo, Estanqueidad
18	1606058M1	1	(B)		1	Seal, Wiper	Joint de racleur	Junta raspador
19	3441920M91	1			1	Rod, Piston	Tige de vérin	Vástago cilindro
20		19	Ref. 19		1	Rod, Piston	Tige de vérin	Vástago cilindro
21	3623323M1	19			2	Bushing	Bague	Anillo
22	339608X1	1			1	Fitting, Grease	Graisneur	Engrasador
23	5001975M91		(C)		1	Kit, Seal	Pochette de joints	Juego de juntas

- A Part number to be advised
Référence pièce à demander
Indicar número de pieza
- C Contains items marked (B)
Comprend les pièces marquées (B)
Incluye las piezas marcadas (B)

- B Included in kit marked (C)
Inclus dans jeu marqué (C)
Incluido en juego marcado (C)



860 880 970 980
TX860B TX870B
TX970B

809 810 811 812 813 814 815 816 817 821 822 823 824 825 841 842 843 844 845
851 852 853 854 855 921 922 923 931 932

67010C02.1

6199042M3

1

Jan-06

Loader Hydraulics
Circuit Hydraulique de Chargeur
Circuito hidráulico cargadora

Lift Cylinder
Vérin de Levage
Gato de elevación

Standard Specification
 Qualité Inférieure
 Baja especificación

C-67011-01.1-A

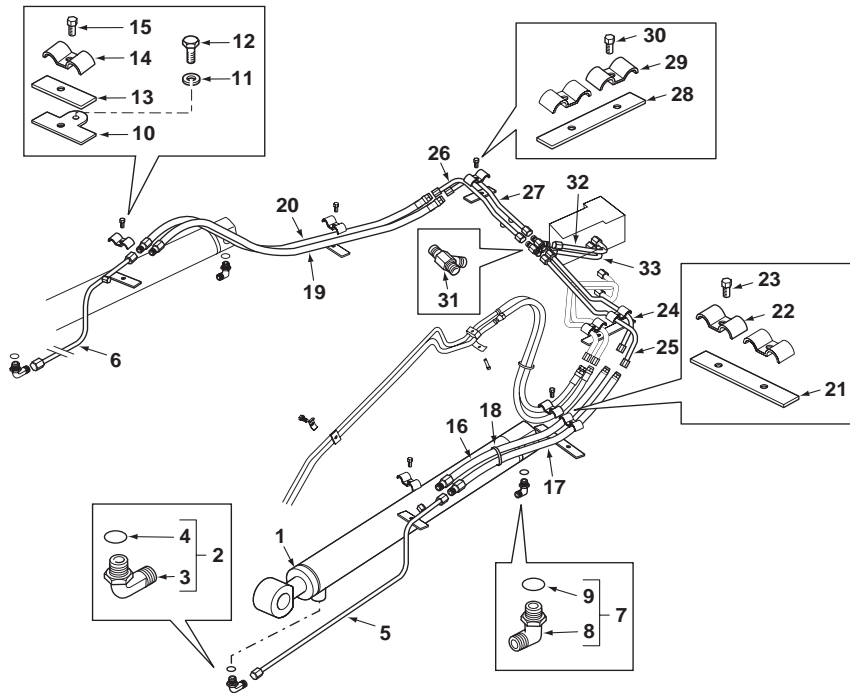

1	6109310M91		67011C02.1 1 Lift	2	Cylinder Assy	Ensemble de vérin	Gato, Conj.
2	835007M91			2	Elbow, 90°	Coude à 90°	Codo, 90°
3		2	Ref. 2	1	Elbow	Coude	Codo
4	835024M1	2		1	O-Ring	Joint torique	Junta de tipo O
5	6109544M91			1	Tube Assy	Tuyauterie	Conjunto de tubería
6	6109548M91			1	Tube Assy	Tuyauterie	Conjunto de tubería
7	835007M91			2	Elbow, 90°	Coude à 90°	Codo, 90°
8		7	Ref. 7	1	Elbow	Coude	Codo
9	835024M1	7		1	O-Ring	Joint torique	Junta de tipo O
10	6109791M91			2	Plate Assy	Ensemble de plaque	Placa, Conj.
11	339374X1	M8		2	Washer, Lock	Rondelle de blocage	Arandela de freno
12	339123X1	M8 x 20		2	Bolt	Boulon	Perno
13	6106109M1			2	Pad, Rubber	Plaque de caoutchouc	Placa, Caucho
14	6101228M1			2	Bracket, Clamp	Bride de fixation	Brida de fijación
15	339123X1	M8 x 20		2	Bolt	Boulon	Perno
16	6109919M91			1	Hose Assy	Ensemble de flexible	Flexible, Conj.
17	6109372M91			1	Hose Assy	Ensemble de flexible	Flexible, Conj.
18	1876229M1			2	Tie, Cable	Attache câble	Enlace de Cable
19	6109919M91			1	Hose Assy	Ensemble de flexible	Flexible, Conj.
20	6109372M91			1	Hose Assy	Ensemble de flexible	Flexible, Conj.
21	6101897M1			1	Pad, Rubber	Plaque de caoutchouc	Placa, Caucho
22	6101228M1			2	Bracket, Clamp	Bride de fixation	Brida de fijación
23	339124X1	M8 x 16		2	Screw	Vis	Tornillo
24	6109412M91			1	Tube Assy	Tuyauterie	Conjunto de tubería
25	6109414M91			1	Tube Assy	Tuyauterie	Conjunto de tubería
26	6109416M91			1	Tube Assy	Tuyauterie	Conjunto de tubería
27	6109418M91			1	Tube Assy	Tuyauterie	Conjunto de tubería
28	6101897M1			2	Pad, Rubber	Plaque de caoutchouc	Placa, Caucho
29	6101228M1			4	Bracket, Clamp	Bride de fixation	Brida de fijación
30	339124X1	M8 x 16		4	Screw	Vis	Tornillo
31	356561X1			2	Tee	Raccord en T	Te
32	6109428M91			1	Tube Assy	Tuyauterie	Conjunto de tubería
33	6109430M91			1	Tube Assy	Tuyauterie	Conjunto de tubería



820
TX760B

801 802 803 804 805 806 807 808 831 832 833 834

67011C01.1

6199042M3

1

Jan-06

Loader Hydraulics
Circuit Hydraulique de Chargeur
Circuito hidráulico cargadora

Lift Cylinder
Vérin de Levage
Gato de elevación

Standard Specification
 Qualité Inférieure
 Baja especificación

C-67011-02.1-B

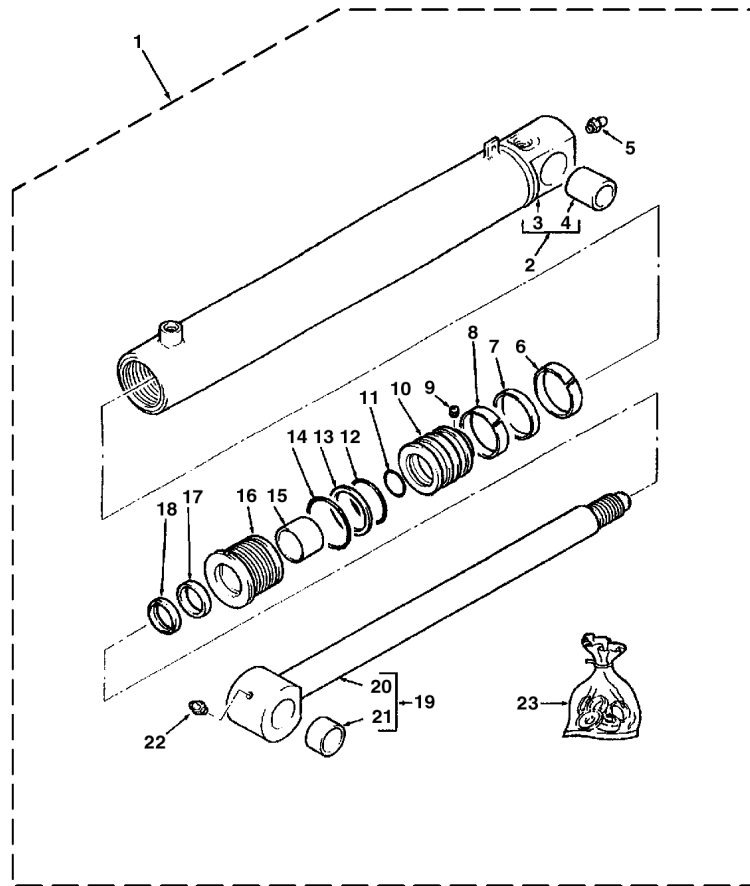

1	6109310M91		67011C01.1 1 Lift	2	Cylinder Assy	Ensemble de vérin	Gato, Conj.
2		1 (A)		1	Tube, Cylinder	Cylindre de vérin	Cilindro de gato
3		2	Ref. 2	1	Tube, Cylinder	Cylindre de vérin	Cilindro de gato
4	3623322M1	2		1	Bushing	Bague	Anillo
5	339608X1	1		1	Fitting, Grease	Graisneur	Engrasador
6	3485889M1	1 (B)		1	Ring, Sealing	Bague d'étanchéité	Anillo, Estanqueidad
7	3485244M91	1 (B)		1	Seal Assy	Ensemble de joint	Junta, Conj.
8	3485889M1	1 (B)		1	Ring, Sealing	Bague d'étanchéité	Anillo, Estanqueidad
9	3402928M1	1		1	Screw	Vis	Tornillo
10	5001981M1	1		1	Piston, Cylinder	Piston de vérin	Pistón de gato
11	359183X1	1 (B)		1	O-Ring	Joint torique	Junta de tipo O
12	359191X1	1 (B)		1	O-Ring	Joint torique	Junta de tipo O
13	378543X1	1 (B)		1	Ring, Backup	Contre-joint	ContraJunta
14	3623640M1	1 (B)		1	O-Ring	Joint torique	Junta de tipo O
15	3443550M1	1 (B)		1	Ring	Anneau	Aro
16	5001980M1	1		1	Gland, Cylinder	Palier de vérin	Palier de gato
17	3403067M1	1 (B)		1	Ring, Sealing	Bague d'étanchéité	Anillo, Estanqueidad
18	1606058M1	1 (B)		1	Seal, Wiper	Joint de racléur	Junta raspador
19	3441920M91	1		1	Rod, Piston	Tige de vérin	Vástago cilindro
20		19	Ref. 19	1	Rod, Piston	Tige de vérin	Vástago cilindro
21	3623323M1	19		2	Bushing	Bague	Anillo
22	339608X1	1		1	Fitting, Grease	Graisneur	Engrasador
23	5001982M91		(C)	1	Kit, Seal	Pochette de joints	Juego de juntas

- A Part number to be advised
 Référence pièce à demander
 Indicar número de pieza
- C Contains items marked (B)
 Comprend les pièces marquées (B)
 Incluye las piezas marcadas (B)

- B Included in kit marked (C)
 Inclus dans jeu marqué (C)
 Incluido en juego marcado (C)



820
 TX760B

801 802 803 804 805 806 807 808 831 832 833 834

67011C02.1

6199042M3

1

Jan-06

Loader Hydraulics
Circuit Hydraulique de Chargeur
Circuito hidráulico cargadora

Lift Cylinder
Vérin de Levage
Gato de elevación

High Specification
Qualité Supérieure
Alta especificación

C-67012-01.1-A

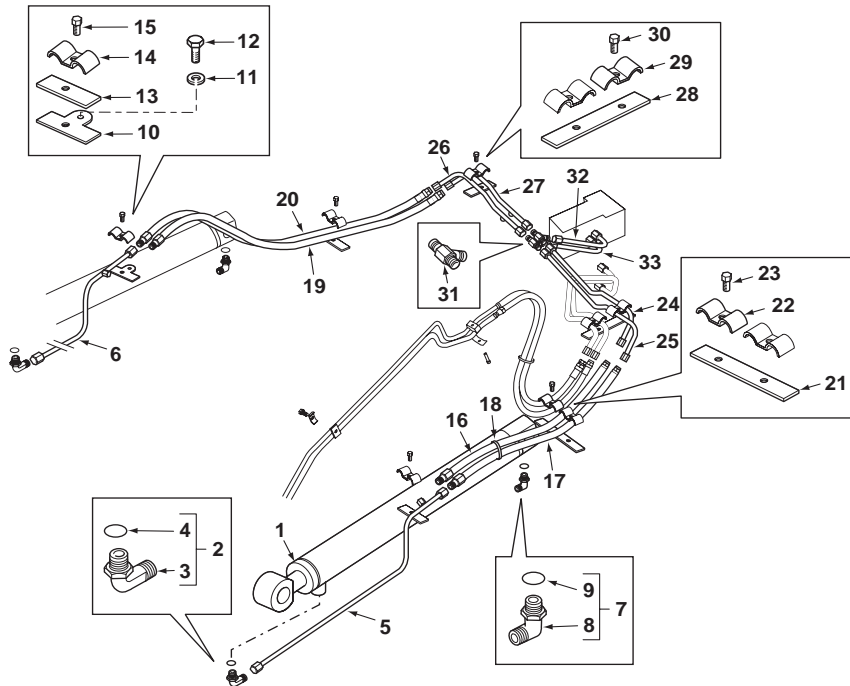

1	6109553M91		67012C02.1 1	2	Cylinder Assy	Ensemble de vérin	Gato, Conj.
2	835007M91			2	Elbow, 90°	Coude à 90°	Codo, 90°
3		2	Ref. 2	1	Elbow	Coude	Codo
4	835024M1	2		1	O-Ring	Joint torique	Junta de tipo O
5	6109544M91			1	Tube Assy	Tuyauterie	Conjunto de tubería
6	6109548M91			1	Tube Assy	Tuyauterie	Conjunto de tubería
7	835007M91			2	Elbow, 90°	Coude à 90°	Codo, 90°
8		7	Ref. 7	1	Elbow	Coude	Codo
9	835024M1	7		1	O-Ring	Joint torique	Junta de tipo O
10	6109791M91			2	Plate Assy	Ensemble de plaque	Placa, Conj.
11	339374X1	M8		2	Washer, Lock	Rondelle de blocage	Arandela de freno
12	339123X1	M8 x 20		2	Bolt	Boulon	Perno
13	6106109M1			2	Pad, Rubber	Plaque de caoutchouc	Placa, Caucho
14	6101228M1			2	Bracket, Clamp	Bride de fixation	Brida de fijación
15	339123X1	M8 x 20		2	Bolt	Boulon	Perno
16	6109919M91			1	Hose Assy	Ensemble de flexible	Flexible, Conj.
17	6109372M91			1	Hose Assy	Ensemble de flexible	Flexible, Conj.
18	1876229M1			2	Tie, Cable	Attache câble	Enlace de Cable
19	6109919M91			1	Hose Assy	Ensemble de flexible	Flexible, Conj.
20	6109372M91			1	Hose Assy	Ensemble de flexible	Flexible, Conj.
21	6101897M1			1	Pad, Rubber	Plaque de caoutchouc	Placa, Caucho
22	6101228M1			2	Bracket, Clamp	Bride de fixation	Brida de fijación
23	339124X1	M8 x 16		2	Screw	Vis	Tornillo
24	6109412M91			1	Tube Assy	Tuyauterie	Conjunto de tubería
25	6109414M91			1	Tube Assy	Tuyauterie	Conjunto de tubería
26	6109416M91			1	Tube Assy	Tuyauterie	Conjunto de tubería
27	6109418M91			1	Tube Assy	Tuyauterie	Conjunto de tubería
28	6101897M1			2	Pad, Rubber	Plaque de caoutchouc	Placa, Caucho
29	6101228M1			4	Bracket, Clamp	Bride de fixation	Brida de fijación
30	339124X1	M8 x 16		4	Screw	Vis	Tornillo
31	356561X1			2	Tee	Raccord en T	Te
32	6109428M91			1	Tube Assy	Tuyauterie	Conjunto de tubería
33	6109430M91			1	Tube Assy	Tuyauterie	Conjunto de tubería



860 880 970 980
 TX860B TX870B
 TX970B

813 814 815 816 817 821 822 823 824 825 841 842 843 844 845 851 852 853 854
 855 921 922 923 931 932

67012C01.1

6199042M3

1

Jan-06

Loader Hydraulics
Circuit Hydraulique de Chargeur
Circuito hidráulico cargadora

Lift Cylinder
Vérin de Levage
Gato de elevación

High Specification
Qualité Supérieure
Alta especificación

C-67012-02.1-B

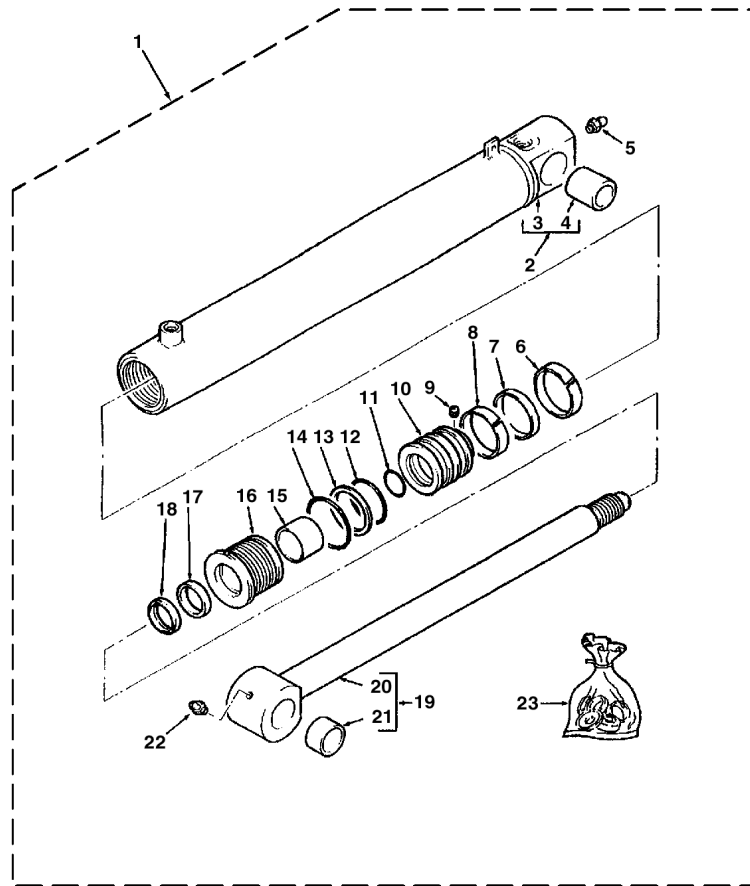

1	6109553M91		67012C01.1	1	2	Cylinder Assy	Ensemble de vérin	Gato, Conj.
2		1	(A)		1	Tube, Cylinder	Cylindre de vérin	Cilindro de gato
3		2	Ref. 2		1	Tube, Cylinder	Cylindre de vérin	Cilindro de gato
4	3623322M1	2			1	Bushing	Bague	Anillo
5	339608X1	1			1	Fitting, Grease	Graisseur	Engrasador
6	3485892M1	1	(B)		1	Ring, Sealing	Bague d'étanchéité	Anillo, Estanqueidad
7	3485245M91	1	(B)		1	Seal Assy	Ensemble de joint	Junta, Conj.
8	3485892M1	1	(B)		1	Ring, Sealing	Bague d'étanchéité	Anillo, Estanqueidad
9	3402928M1	1			1	Screw	Vis	Tornillo
10	3487180M1	1			1	Piston, Cylinder	Piston de vérin	Pistón de gato
11	359183X1	1	(B)		1	O-Ring	Joint torique	Junta de tipo O
12	359193X1	1	(B)		1	O-Ring	Joint torique	Junta de tipo O
13	1606735M1	1	(B)		1	Ring, Backup	Contre-joint	ContraJunta
14	3623641M1	1	(B)		1	O-Ring	Joint torique	Junta de tipo O
15	3443550M1	1	(B)		1	Ring	Anneau	Aro
16	5002159M1	1			1	Gland, Cylinder	Palier de vérin	Palier de gato
17	3403067M1	1	(B)		1	Ring, Sealing	Bague d'étanchéité	Anillo, Estanqueidad
18	1606058M1	1	(B)		1	Seal, Wiper	Joint de racleur	Junta raspador
19	3441920M91	1			1	Rod, Piston	Tige de vérin	Vástago cilindro
20		19	Ref. 19		1	Rod, Piston	Tige de vérin	Vástago cilindro
21	3623323M1	19			2	Bushing	Bague	Anillo
22	339608X1	1			1	Fitting, Grease	Graisseur	Engrasador
23	5001975M91		(C)		1	Kit, Seal	Pochette de joints	Juego de juntas

- A Part number to be advised
Référence pièce à demander
Indicar número de pieza
- C Contains items marked (B)
Comprend les pièces marquées (B)
Incluye las piezas marcadas (B)

- B Included in kit marked (C)
Inclus dans jeu marqué (C)
Incluido en juego marcado (C)



860 880 970 980
TX860B TX870B
TX970B

813 814 815 816 817 821 822 823 824 825 841 842 843 844 845 851 852 853 854
855 921 922 923 931 932

67012C02.1

6199042M3

1

Jan-06

H - Operator's Environment • Environnement opérateur • Entorno del operario

Anti Vandal Kit	98106C01.1	Coffret de Accessoires Siège	Juego antivandalismo
Cab - 4 Post ROPS	46003C01.1	Cabine - 4 Poteau ROPS	Cabina - 4 poste ROPS
Cab - 4 Post ROPS	46005C01.1	Cabine - 4 Poteau ROPS	Cabina - 4 poste ROPS
Cab - Door	46015C02.1	Cabine - Porte	Cabina - Puerta
Cab - Door	46016C02.1	Cabine - Porte	Cabina - Puerta
Cab - Frame	46015C01.1	Cabine - Bâti	Cabina - Bastidor
Cab - Frame	46016C01.1	Cabine - Bâti	Cabina - Bastidor
Cab - Front Worklight	46015C05.1	Cabine - Phare de Travail Avant	Cabina - Luz de trabajo delanteras
Cab - Front Worklight	46016C05.1	Cabine - Phare de Travail Avant	Cabina - Luz de trabajo delanteras
Cab - Inner Roof	46015C07.1	Cabine - Toit Intérieur	Cabina - Techo interior
Cab - Inner Roof	46016C07.1	Cabine - Toit Intérieur	Cabina - Techo interior
Cab - Outer Roof	46015C04.1	Cabine - Toit Extérieur	Cabina - Techo exterior
Cab - Outer Roof	46016C04.1	Cabine - Toit Extérieur	Cabina - Techo exterior
Cab - Rear Window	46015C03.1	Cabine - Lunette Arrière	Cabina - Ventana trasera
Cab - Rear Window	46016C03.1	Cabine - Lunette Arrière	Cabina - Ventana trasera
Cab - Rear Worklight	46003C02.1	Cabine - Phare de Travail Arriere	Cabina - Faro de trabajo trasera
Cab - Rear Worklight	46005C02.1	Cabine - Phare de Travail Arriere	Cabina - Faro de trabajo trasera
Cab - Rear Worklight	46015C06.1	Cabine - Phare de Travail Arriere	Cabina - Faro de trabajo trasera
Cab - Rear Worklight	46016C06.1	Cabine - Phare de Travail Arriere	Cabina - Faro de trabajo trasera
Cab Environment - Air Conditioning Installation	49011C01.1	Poste de Conduite - Installation de Climatisation	Puesto de conducción - Instalación climatizador
Cab Environment - Air Conditioning Installation	49011C03.1	Poste de Conduite - Installation de Climatisation	Puesto de conducción - Instalación climatizador
Cab Environment - Air Conditioning Unit	49011C04.1	Poste de Conduite - Climatiseur	Puesto de conducción - Climatizador
Cab Environment - Heater Installation	49010C01.1	Poste de Conduite - Circuit Chauffage	Puesto de conducción - Circuito de calefacción
Cab Environment - Heater Installation	49010C02.1	Poste de Conduite - Circuit Chauffage	Puesto de conducción - Circuito de calefacción
Cab Environment - Heater Installation	49011C02.1	Poste de Conduite - Circuit Chauffage	Puesto de conducción - Circuito de calefacción
Cab Environment - Heater Unit	49010C03.1	Poste de Conduite - Dispositif de Chauffage	Puesto de conducción - Dispositivo calefactor
Cab Environment - Less Heater Unit	49012C01.1	Poste de Conduite - Sans Dispositif de Chauffage	Puesto de conducción - Sin dispositivo calefactor
Cab Trim - Cab Mounting	47010C01.1	Habillage de Cabine - Pièces de Montage	Guarnición de cabina - Piezas de montaje
Cab Trim - Cab Mounting	47011C01.1	Habillage de Cabine - Pièces de Montage	Guarnición de cabina - Piezas de montaje
Cab Trim - Cab Mounting	47012C01.1	Habillage de Cabine - Pièces de Montage	Guarnición de cabina - Piezas de montaje
Cab Trim - Cab Mounting	47014C01.1	Habillage de Cabine - Pièces de Montage	Guarnición de cabina - Piezas de montaje
Cab Trim - Cab Mounting	47015C01.1	Habillage de Cabine - Pièces de Montage	Guarnición de cabina - Piezas de montaje
Cab Trim - Cab Mounting	47016C01.1	Habillage de Cabine - Pièces de Montage	Guarnición de cabina - Piezas de montaje
Cab Trim - Console	47010C03.1	Habillage de Cabine - Console	Guarnición de cabina - Consola
Cab Trim - Console	47011C03.1	Habillage de Cabine - Console	Guarnición de cabina - Consola
Cab Trim - Console	47014C03.1	Habillage de Cabine - Console	Guarnición de cabina - Consola
Cab Trim - Console	47015C03.1	Habillage de Cabine - Console	Guarnición de cabina - Consola
Cab Trim - Floorplate	47010C02.1	Habillage de Cabine - Plaque du Sol	Guarnición de cabina - Placa de piso



H - Operator's Environment • Environnement opérateur • Entorno del operario

Cab Trim - Floorplate.....	47011C02.1	Habillage de Cabine - Plaque du Sol	Guarnición de cabina - Placa de piso
Cab Trim - Floorplate.....	47012C02.1	Habillage de Cabine - Plaque du Sol	Guarnición de cabina - Placa de piso
Cab Trim - Floorplate.....	47014C02.1	Habillage de Cabine - Plaque du Sol	Guarnición de cabina - Placa de piso
Cab Trim - Floorplate.....	47015C02.1	Habillage de Cabine - Plaque du Sol	Guarnición de cabina - Placa de piso
Cab Trim - Floorplate.....	47016C02.1	Habillage de Cabine - Plaque du Sol	Guarnición de cabina - Placa de piso
Cab Trim - Windscreen Wiper	47010C04.1	Habillage de Cabine - Essuie-Glace	Guarnición de cabina - Limpiaparabrisas
Cab Trim - Windscreen Wiper	47011C04.1	Habillage de Cabine - Essuie-Glace	Guarnición de cabina - Limpiaparabrisas
Cab Trim - Windscreen Wiper	47014C04.1	Habillage de Cabine - Essuie-Glace	Guarnición de cabina - Limpiaparabrisas
Cab Trim - Windscreen Wiper	47015C04.1	Habillage de Cabine - Essuie-Glace	Guarnición de cabina - Limpiaparabrisas
Control Box.....	41010C02.1	Boîte de Contrôle	Caja de control
Control Box.....	41010C03.1	Boîte de Contrôle	Caja de control
Control Box.....	41010C04.1	Boîte de Contrôle	Caja de control
Control Box - Installation	41010C01.1	Boîte de Contrôle - Montage	Caja de control - Instalación
Front Console.....	55001C01.1	Console Avant	Consola delantera
Front Console.....	55001C02.1	Console Avant	Consola delantera
Front Console.....	55002C01.1	Console Avant	Consola delantera
Front Console.....	55002C02.1	Console Avant	Consola delantera
Front Console.....	55003C01.1	Console Avant	Consola delantera
Front Console.....	55003C02.1	Console Avant	Consola delantera
Front Console.....	55004C01.1	Console Avant	Consola delantera
Front Console.....	55004C02.1	Console Avant	Consola delantera
Front Console.....	55005C01.1	Console Avant	Consola delantera
Front Console.....	55005C02.1	Console Avant	Consola delantera
Front Console.....	55006C01.1	Console Avant	Consola delantera
Front Console.....	55006C02.1	Console Avant	Consola delantera
Front Console.....	55009C01.1	Console Avant	Consola delantera
Front Console.....	55009C02.1	Console Avant	Consola delantera
Front Console.....	55010C01.1	Console Avant	Consola delantera
Front Console.....	55010C02.1	Console Avant	Consola delantera
Front Console - Forward/Reverse Switch.....	55001C04.1	Console Avant - Interrupteur de Marche Avant/Arrière	Consola delantera - Interruptor de marcha adelante / atrás
Front Console - Forward/Reverse Switch.....	55002C04.1	Console Avant - Interrupteur de Marche Avant/Arrière	Consola delantera - Interruptor de marcha adelante / atrás
Front Console - Forward/Reverse Switch.....	55003C04.1	Console Avant - Interrupteur de Marche Avant/Arrière	Consola delantera - Interruptor de marcha adelante / atrás
Front Console - Forward/Reverse Switch.....	55004C04.1	Console Avant - Interrupteur de Marche Avant/Arrière	Consola delantera - Interruptor de marcha adelante / atrás
Front Console - Forward/Reverse Switch.....	55005C04.1	Console Avant - Interrupteur de Marche Avant/Arrière	Consola delantera - Interruptor de marcha adelante / atrás
Front Console - Forward/Reverse Switch.....	55006C04.1	Console Avant - Interrupteur de Marche Avant/Arrière	Consola delantera - Interruptor de marcha adelante / atrás
Front Console - Forward/Reverse Switch.....	55009C04.1	Console Avant - Interrupteur de Marche Avant/Arrière	Consola delantera - Interruptor de marcha adelante / atrás
Front Console - Forward/Reverse Switch.....	55010C04.1	Console Avant - Interrupteur de Marche Avant/Arrière	Consola delantera - Interruptor de marcha adelante / atrás
Front Console - Instrument Panel.....	55001C03.1	Console Avant - Tableau de Bord	Consola delantera - Tablero de instrumentos



H - Operator's Environment • Environnement opérateur • Entorno del operario

Front Console - Instrument Panel.....	55002C03.1	Console Avant - Tableau de Bord	Consola delantera - Tablero de instrumentos
Front Console - Instrument Panel.....	55003C03.1	Console Avant - Tableau de Bord	Consola delantera - Tablero de instrumentos
Front Console - Instrument Panel.....	55004C03.1	Console Avant - Tableau de Bord	Consola delantera - Tablero de instrumentos
Front Console - Instrument Panel.....	55005C03.1	Console Avant - Tableau de Bord	Consola delantera - Tablero de instrumentos
Front Console - Instrument Panel.....	55006C03.1	Console Avant - Tableau de Bord	Consola delantera - Tablero de instrumentos
Front Console - Instrument Panel.....	55009C03.1	Console Avant - Tableau de Bord	Consola delantera - Tablero de instrumentos
Front Console - Instrument Panel.....	55010C03.1	Console Avant - Tableau de Bord	Consola delantera - Tablero de instrumentos
Mirrors - Cab.....	61001AC01.1	Rétroviseurs - Cabine	Retrovisores - Cabina
Mirrors - Cab.....	61001AC01.1	Rétroviseurs - Cabine	Retrovisores - Cabina
Mirrors - Cab.....	61001C01.1	Rétroviseurs - Cabine	Retrovisores - Cabina
Mirrors - Cab.....	61001C01.1	Rétroviseurs - Cabine	Retrovisores - Cabina
Mirrors - ROPS.....	61002C01.1	Rétroviseurs - ROPS	Retrovisores - ROPS
Seat - Fabric Trim.....	62001C02.1	Siège - Finition Tissu	Asiento - Tapizado de tela
Seat - Fabric Trim.....	62002C02.1	Siège - Finition Tissu	Asiento - Tapizado de tela
Seat - Seat Installation.....	62001C01.1	Siège - Installation du Siège	Asiento - Instalación de asiento
Seat - Seat Installation.....	62002C01.1	Siège - Installation du Siège	Asiento - Instalación de asiento
Seat - Seat Installation.....	62003C01.1	Siège - Installation du Siège	Asiento - Instalación de asiento
Seat - Seat Installation.....	62004C01.1	Siège - Installation du Siège	Asiento - Instalación de asiento
Seat - Weatherproof P.V.C. Trim.....	62003C02.1	Siège - Finition P.V.C. Étanche	Asiento - Tapizado de PVC
Seat - Weatherproof P.V.C. Trim.....	62004C02.1	Siège - Finition P.V.C. Étanche	Asiento - Tapizado de PVC
Side Console.....	56010C01.1	Console Latérale	Consola lateral
Side Console.....	56011C01.1	Console Latérale	Consola lateral
Side Console.....	56012C01.1	Console Latérale	Consola lateral
Side Console.....	56013C01.1	Console Latérale	Consola lateral
Side Console.....	56014C01.1	Console Latérale	Consola lateral
Side Console.....	56015C01.1	Console Latérale	Consola lateral
Side Console - Fuse & Relay Board.....	56010C03.1	Console Latérale - Tableau de Fusibles & Relais	Consola lateral - Tablero de fusibles y relés
Side Console - Fuse & Relay Board.....	56011C03.1	Console Latérale - Tableau de Fusibles & Relais	Consola lateral - Tablero de fusibles y relés
Side Console - Fuse & Relay Board.....	56012C03.1	Console Latérale - Tableau de Fusibles & Relais	Consola lateral - Tablero de fusibles y relés
Side Console - Fuse & Relay Board.....	56013C03.1	Console Latérale - Tableau de Fusibles & Relais	Consola lateral - Tablero de fusibles y relés
Side Console - Fuse & Relay Board.....	56014C03.1	Console Latérale - Tableau de Fusibles & Relais	Consola lateral - Tablero de fusibles y relés
Side Console - Fuse & Relay Board.....	56015C03.1	Console Latérale - Tableau de Fusibles & Relais	Consola lateral - Tablero de fusibles y relés
Side Console - Instrument Panel.....	56010C02.1	Console Latérale - Tableau de Bord	Consola lateral - Tablero de instrumentos
Side Console - Instrument Panel.....	56011C02.1	Console Latérale - Tableau de Bord	Consola lateral - Tablero de instrumentos
Side Console - Instrument Panel.....	56012C02.1	Console Latérale - Tableau de Bord	Consola lateral - Tablero de instrumentos
Side Console - Instrument Panel.....	56013C02.1	Console Latérale - Tableau de Bord	Consola lateral - Tablero de instrumentos
Side Console - Instrument Panel.....	56014C02.1	Console Latérale - Tableau de Bord	Consola lateral - Tablero de instrumentos
Side Console - Instrument Panel.....	56015C02.1	Console Latérale - Tableau de Bord	Consola lateral - Tablero de instrumentos



Anti Vandal Kit
Coffret de Accessoires Siège
Juego antivandalismo

C-98106-01.1-A

1	6102824M91			1	Plate, Cover	Plaque de fermeture	Placa de cierre
2		1	 Ref. 1	1	Plate	Plaque	Placa
3	6102609M1	1		1	Gasket	Joint	Empaquetadura
4	6102590M1			1	Cover	Cache	Tapa

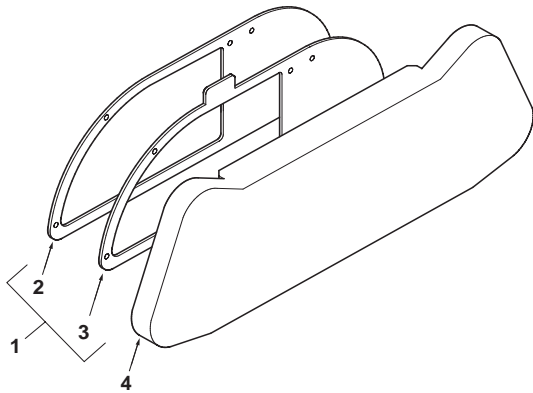

820 860 880
 TX760B TX860B
 TX870B

802 804 806 808 810 812 814 816 822 824 832 834 842 844 852 854

98106C01.1

6199042M3

1

Jan-06

Cab
Cabine
Cabina

4 Post ROPS
4 Poteau ROPS
4 poste ROPS

C-46003-01.1-A

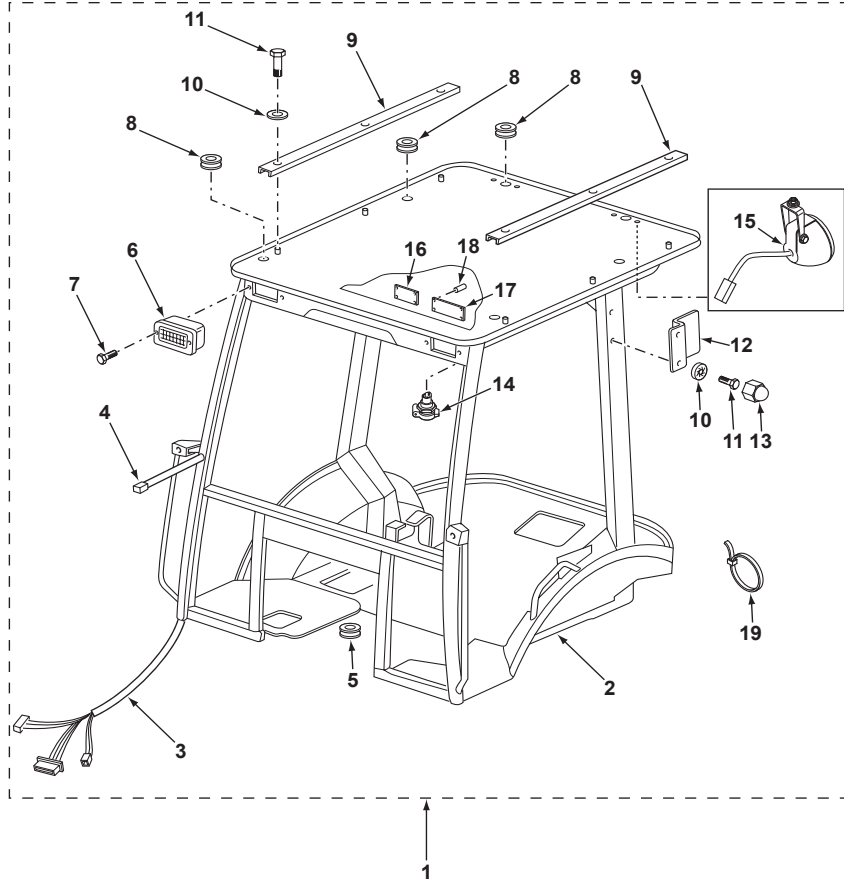

1	6097002M93			1	ROPS Assy	Ensemble de Rops	ROPS, Conj.
2	6097003M93	1		1	Frame Assy	Ensemble de bâti	Bastidor, Conj.
3	6097005M91	1		1	Harness Assy	Ensemble de faisceau	Haz, Conj.
4	6101354M91	1		2	Harness	Faisceau	Haz
5	6099579M1	1		2	Grommet	Passe-fil	Pasa cable
6	6097004M91	1		2	Lamp Assy, Work	Ensemble phare travail	Faro de trabajo, Conj.
7	6099456M1	1		4	Screw	Vis	Tornillo
8	6099447M1	1	22 x 28 x 4 mm	6	Grommet	Passe-fil	Pasa cable
9	6097006M1	1		2	Channel	Canal	Canal
10	6097008M1	1	M8	10	Washer	Rondelle	Arandela
11	339123X1	1	M8 x 20	10	Bolt	Boulon	Perno
12	6097015M1	1		2	Support	Support	Soporte
13	6097009M1	1		4	Cap	Chapeau	Sombbrero
14	3517621M91	1		2	Socket	Prise de courant	Toma de corriente
15	6110678M91	1	46003C02.1	1	Lamp Assy, Work	Ensemble phare travail	Faro de trabajo, Conj.
16	6002676M1	1		1	Plate, Warning	Plaque avertissement	Placa de advertencia
17		1	Ref. 1	1	Plate, Approval	Plaque homologation	Placa homologación
18	519566M1	1		8	Rivet	Rivet	Remache
19	6099460M1	1		X	Tie, Cable	Attache câble	Enlace de Cable
NI	6110681M91	1	[Cab Trim - Floorplate]	1	Plate Assy	Ensemble de plaque	Placa, Conj.



820 860 880
TX760B TX860B
TX870B

802 804 806 808 810 812 814 816 822 824 832 834 842 844 852 854

46003C01.1

6199042M3

1

Jan-06

Cab
Cabine
Cabina

4 Post ROPS
4 Poteau ROPS
4 poste ROPS

C-46005-01.1-A

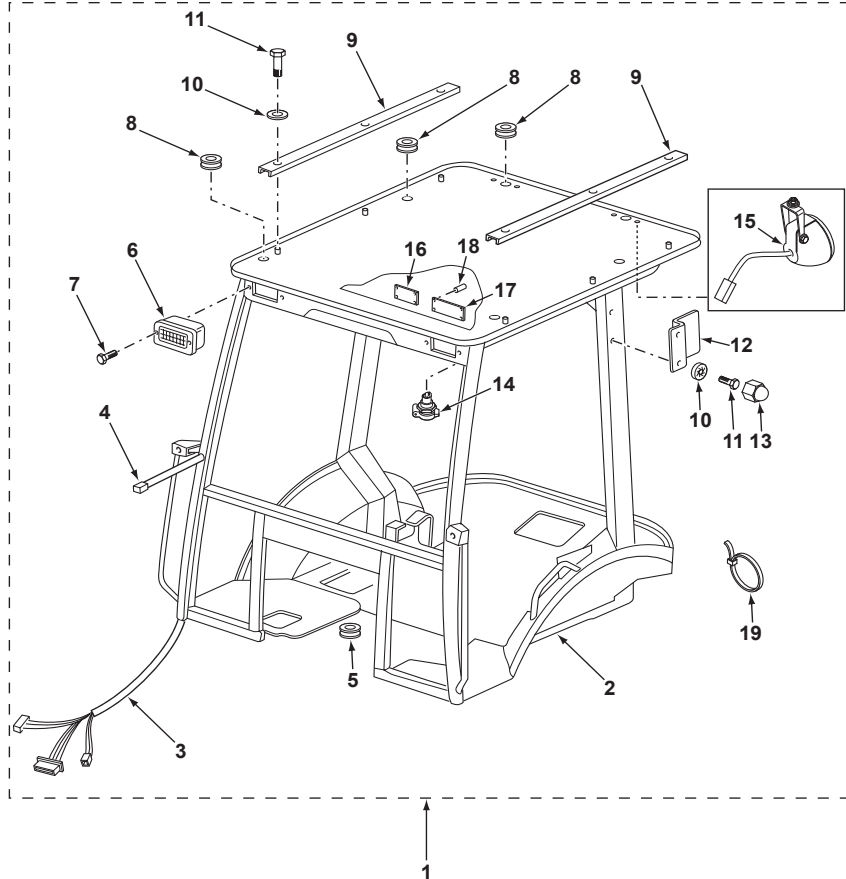

1	6097002M93			1	ROPS Assy	Ensemble de Rops	ROPS, Conj.
2	6097003M93	1		1	Frame Assy	Ensemble de bâti	Bastidor, Conj.
3	6097005M91	1		1	Harness Assy	Ensemble de faisceau	Haz, Conj.
4	6101354M91	1		2	Harness	Faisceau	Haz
5	6099579M1	1		2	Grommet	Passe-fil	Pasa cable
6	6097004M91	1		2	Lamp Assy, Work	Ensemble phare travail	Faro de trabajo, Conj.
7	6099456M1	1		4	Screw	Vis	Tornillo
8	6099447M1	1	22 x 28 x 4 mm	6	Grommet	Passe-fil	Pasa cable
9	6097006M1	1		2	Channel	Canal	Canal
10	6097008M1	1	M8	10	Washer	Rondelle	Arandela
11	339123X1	1	M8 x 20	10	Bolt	Boulon	Perno
12	6097015M1	1		2	Support	Support	Soporte
13	6097009M1	1		4	Cap	Chapeau	Sombbrero
14	3517621M91	1		2	Socket	Prise de courant	Toma de corriente
15	6110678M91	1	46005C02.1 1	2	Lamp Assy, Work	Ensemble phare travail	Faro de trabajo, Conj.
16	6002676M1	1		1	Plate, Warning	Plaque avertissement	Placa de advertencia
17		1	Ref. 1	1	Plate, Approval	Plaque homologation	Placa homologación
18	519566M1	1		8	Rivet	Rivet	Remache
19	6099460M1	1		X	Tie, Cable	Attache câble	Enlace de Cable



820
TX760B

808

46005C01.1

6199042M3

1

Jan-06

Cab
Cabine
Cabina

Door
Porte
Puerta

C-46015-02.1-A

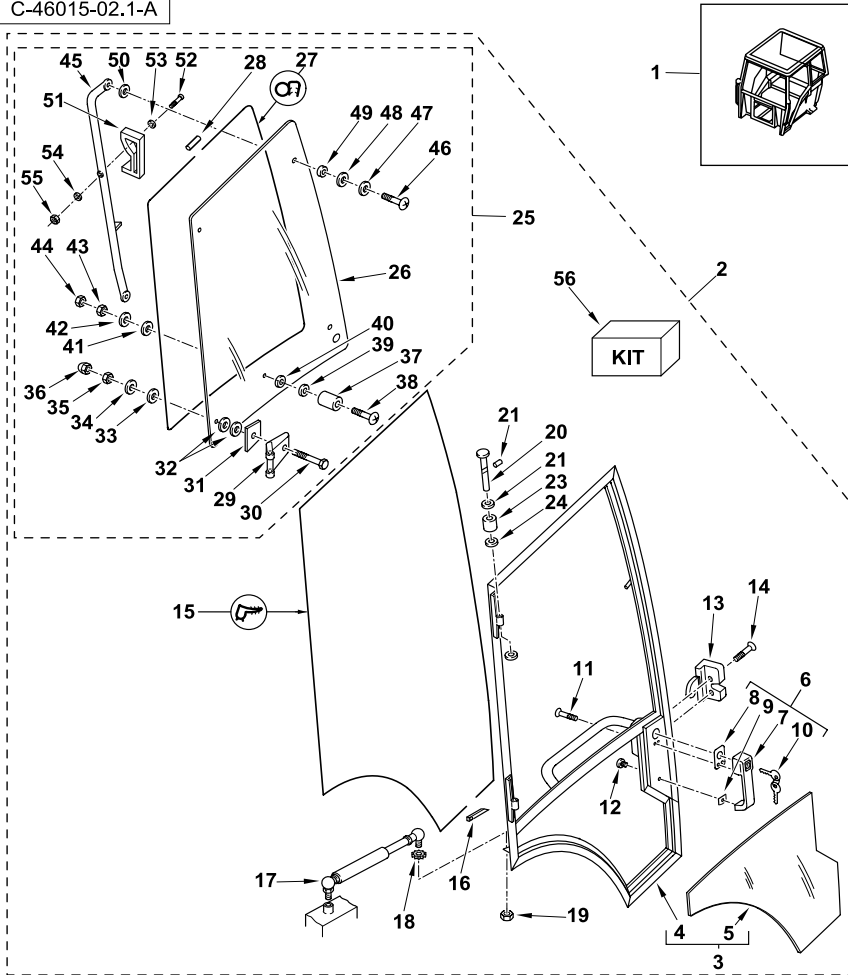

1	6099759M93G Y02		1	Cab Assy	Ensemble de cabine	Cabina, Conj.
2	6099411M91	1	1	Door Assy	Ensemble de porte	Puerta, Conj.
2	6099412M91	1	1	Door Assy	Ensemble de porte	Puerta, Conj.
3	6099413M91	2	1	Frame Assy	Ensemble de bâti	Bastidor, Conj.
3	6099414M91	2	1	Frame Assy	Ensemble de bâti	Bastidor, Conj.
4	6099439M91	3	1	Frame	Bâti	Bastidor
4	6099440M91	3	1	Frame	Bâti	Bastidor
5	6099906M1	2	1	Glass	Vitre	Cristal
5	6099907M1	2	1	Glass	Vitre	Cristal
6	6099584M92	2	1	Handle Assy	Ensemble de poignée	Empuñadura, Conj.
7		6	1	Handle	Poignée	Asa
8	6099585M1	6	1	Seal	Joint	Junta
9	6099586M1	6	1	Seal	Joint	Junta
10	6107891M1	6	1	Terex Logo (Pair)	Lot de clés	Juego de llaves
11	3007934X1	2	3	M6 x 16	Screw	Tornillo
12	3512448M1	2	1	Plug	Bouchon	Tapón
13	3512369M91	2	1	Latching Device	Verrou	Cerrojo
13	3512368M91	2	1	Latching Device	Verrou	Cerrojo
14	3512498M1	2	1	M8 x 35	Screw	Vis
15	6099417M1	2	1	4400 mm	Strip, Sealing	Bande d'étanchéité
16	6099418M1	2	1	50 mm	Joint	Articulation
17	3512902M92	2	1	Gas Strut	Vérin à gaz	Gato de gas
18	391025X1	2	1	M8	Washer, Lock	Rondelle de blocage
19	394367X1	2	1	M8	Nut, Lock	Écrou de blocage
20	3512879M1	2	2		Pin	Axe
21	3009420X1	2	2	M5 x 6	Screw	Vis
22	3512619M1	2	7		Washer	Rondelle
23	6099231M1	2	4		Spacer	Entretoise
24	3512433M1	2	6		Washer	Rondelle
25	6099419M91	2	1	Window Assy	Ensemble de fenêtre	Ventana, Conj.
25	6099420M91	2	1	Window Assy	Ensemble de fenêtre	Ventana, Conj.
26	6099904M1	25	1		Glass	Vitre
26	6099905M1	25	1		Glass	Vitre
27	6099421M1	25	1	3400 mm	Strip, Sealing	Bande d'étanchéité
28	6099418M1	25	1	50 mm	Joint	Articulation
29	3512937M1	25	1		Hinge	Charnière
30	391096X1	25	2	M6 x 35	Screw	Vis
31	3512940M1	25	2		Seal	Joint
32	3512450M1	25	4	6,2 x 12,5 x 10	Spacer	Entretoise
33	3512561M1	25	2	13,5 x 35 x 3	Washer, Rubber	Rondelle élastique
34	3512435M1	25	2	M6	Washer	Rondelle
35	1441500X1	25	2	M6	Nut, Lock	Écrou de blocage
36	3512502M1	25	2		Cap	Chapeau



820 860 880 970 980
TX760B TX860B
TX870B TX970B

801 803 805 807 809 811 813 815 817 821 823 825 831 833 841 843 845 851 853
855 921 922 923 931 932

46015C02.1

6199042M3

1

Jan-06

Cab
Cabine
Cabina

Door
Porte
Puerta

C-46015-02.1-A

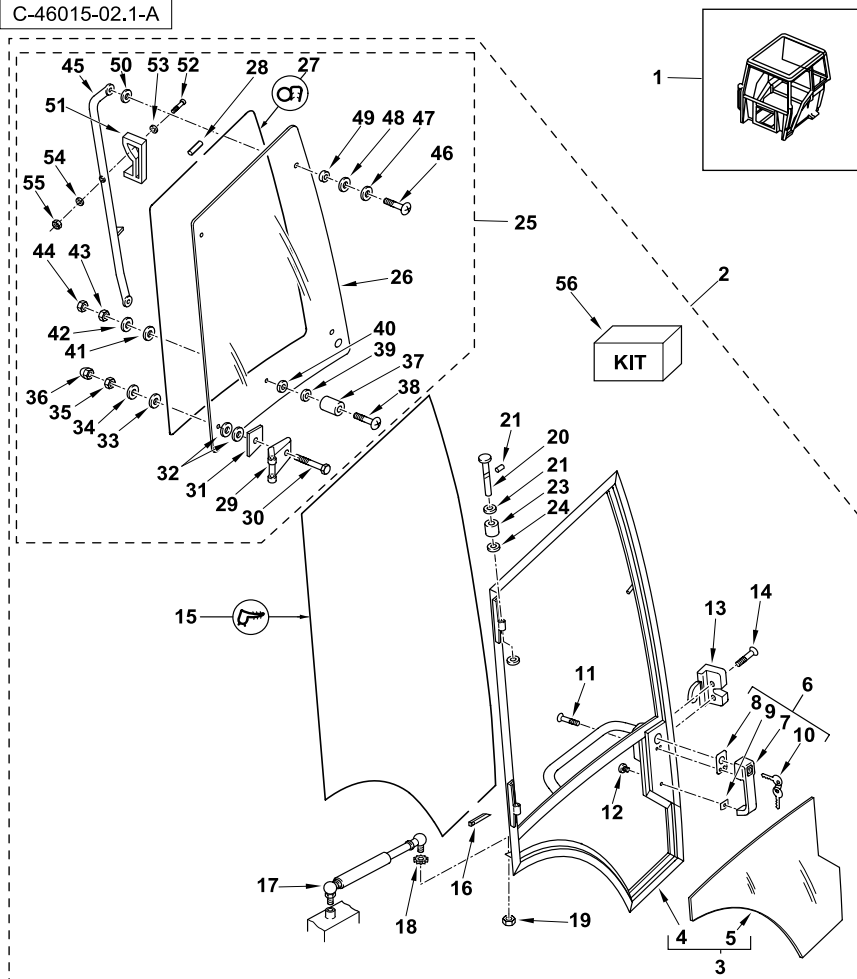

37	3512363M1	25		1	Retainer	Dispositif de retenue	Fijación
38	6106471M1	25	M6 x 30	1	Screw	Vis	Tornillo
39	6099248M1	25		1	Washer, Rubber	Rondelle élastique	Arandela elástica
40	6099406M1	25		1	Spacer	Entretoise	Traviesa
41	3512561M1	25	13,5 x 35 x 3	1	Washer, Rubber	Rondelle élastique	Arandela elástica
42	3512435M1	25	M6	1	Washer	Rondelle	Arandela
43	1441500X1	25	M6	1	Nut, Lock	Écrou de blocage	Tuerca de retención
44	3512502M1	25		1	Cap	Chapeau	Sombbrero
45	6099422M91	25		1	Handle Assy	Ensemble de poignée	Empuñadura, Conj.
46	3512392M1	25	M6 x 25	2	Screw	Vis	Tornillo
47	3512435M1	25	M6	2	Washer	Rondelle	Arandela
48	3512561M1	25	13,5 x 35 x 3	2	Washer, Rubber	Rondelle élastique	Arandela elástica
49	3512450M1	25	6,2 x 12,5 x 10	2	Spacer	Entretoise	Traviesa
50	3512561M1	25	13,5 x 35 x 3	2	Washer, Rubber	Rondelle élastique	Arandela elástica
51	6099423M1	25		1	Handle	Poignée	Asa
52	391884X1	25	M6 x 50	1	Screw	Vis	Tornillo
53	6106467M1	25	6,4 x 18 x 2 mm	1	Washer	Rondelle	Arandela
54	1441500X1	25	M6	1	Nut, Lock	Écrou de blocage	Tuerca de retención
55	3512502M1	25		1	Cap	Chapeau	Sombbrero
56	3621392M91	2		1	Kit, Adhesive	Jeu d'adhésifs	Empaque de cola



820 860 880 970 980
TX760B TX860B
TX870B TX970B

801 803 805 807 809 811 813 815 817 821 823 825 831 833 841 843 845 851 853
855 921 922 923 931 932

46015C02.1

6199042M3

1

Jan-06

Cab
Cabine
Cabina

Door
Porte
Puerta

C-46016-02.1-A

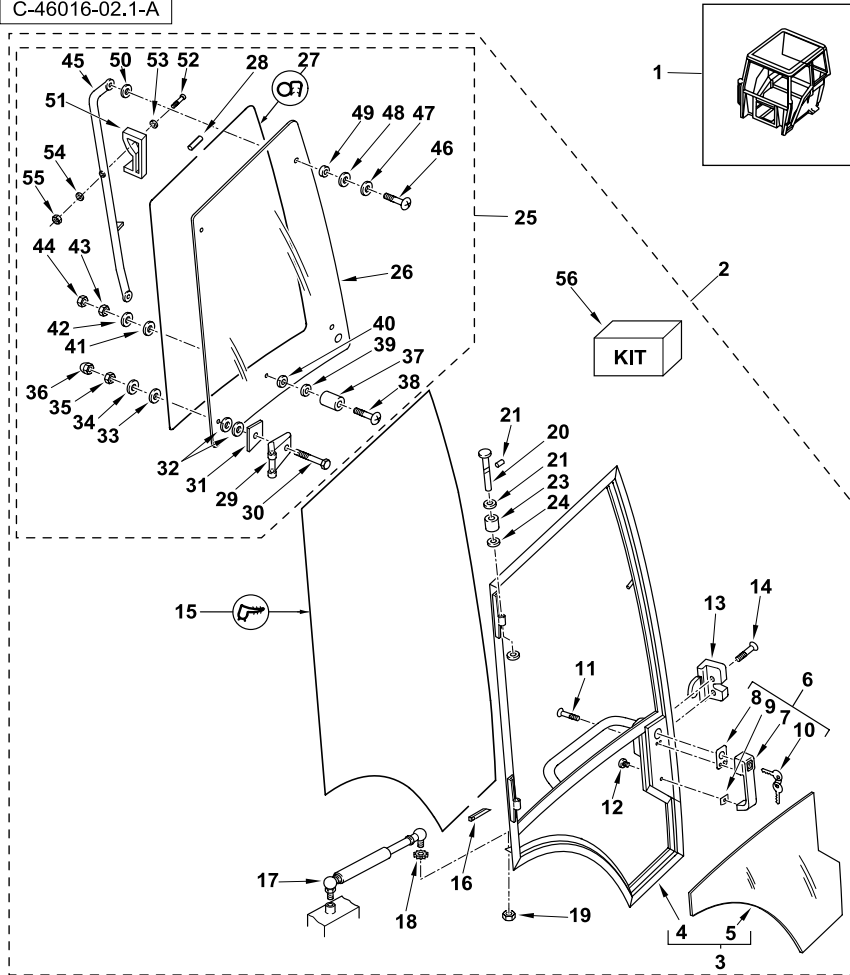

1	6099764M92Y02			1	Cab Assy	Ensemble de cabine	Cabina, Conj.
2	6099411M91	1	◀	1	Door Assy	Ensemble de porte	Puerta, Conj.
2	6099412M91	1	▶	1	Door Assy	Ensemble de porte	Puerta, Conj.
3	6099413M91	2	◀	1	Frame Assy	Ensemble de bâti	Bastidor, Conj.
3	6099414M91	2	▶	1	Frame Assy	Ensemble de bâti	Bastidor, Conj.
4	6099439M91	3	◀	1	Frame	Bâti	Bastidor
4	6099440M91	3	▶	1	Frame	Bâti	Bastidor
5	6099906M1	2	◀	1	Glass	Vitre	Cristal
5	6099907M1	2	▶	1	Glass	Vitre	Cristal
6	6099584M92	2		1	Handle Assy	Ensemble de poignée	Empuñadura, Conj.
7		6	▶	1	Handle	Poignée	Asa
8	6099585M1	6		1	Seal	Joint	Junta
9	6099586M1	6		1	Seal	Joint	Junta
10	6107891M1	6		1	Terex Logo (Pair)	Lot de clés	Juego de llaves
11	3007934X1	2	M6 x 16	3	Screw	Vis	Tornillo
12	3512448M1	2		1	Plug	Bouchon	Tapón
13	3512369M91	2	◀	1	Latching Device	Verrou	Cerrojo
13	3512368M91	2	▶	1	Latching Device	Verrou	Cerrojo
14	3512498M1	2	M8 x 35	1	Screw	Vis	Tornillo
15	6099417M1	2	4400 mm	1	Strip, Sealing	Bande d'étanchéité	Banda estanqueidad
16	6099418M1	2	50 mm	1	Joint	Articulation	Articulación
17	3512902M92	2		1	Gas Strut	Vérin à gaz	Gato de gas
18	391025X1	2	M8	1	Washer, Lock	Rondelle de blocage	Arandela de freno
19	394367X1	2	M8	1	Nut, Lock	Écrou de blocage	Tuerca de retención
20	3512879M1	2		2	Pin	Axe	Pasador
21	3009420X1	2	M5 x 6	2	Screw	Vis	Tornillo
22	3512619M1	2		7	Washer	Rondelle	Arandela
23	6099231M1	2		4	Spacer	Entretoise	Traviesa
24	3512433M1	2		6	Washer	Rondelle	Arandela
25	6099419M91	2	◀	1	Window Assy	Ensemble de fenêtre	Ventana, Conj.
25	6099420M91	2	▶	1	Window Assy	Ensemble de fenêtre	Ventana, Conj.
26	6099904M1	25	◀	1	Glass	Vitre	Cristal
26	6099905M1	25	▶	1	Glass	Vitre	Cristal
27	6099421M1	25	3400 mm	1	Strip, Sealing	Bande d'étanchéité	Banda estanqueidad
28	6099418M1	25	50 mm	1	Joint	Articulation	Articulación
29	3512937M1	25		1	Hinge	Charnière	Bisagra
30	391096X1	25	M6 x 35	2	Screw	Vis	Tornillo
31	3512940M1	25		2	Seal	Joint	Junta
32	3512450M1	25	6,2 x 12,5 x 10	4	Spacer	Entretoise	Traviesa
33	3512561M1	25	13,5 x 35 x 3	2	Washer, Rubber	Rondelle élastique	Arandela elástica
34	3512435M1	25	M6	2	Washer	Rondelle	Arandela
35	1441500X1	25	M6	2	Nut, Lock	Écrou de blocage	Tuerca de retención
36	3512502M1	25		2	Cap	Chapeau	Sombbrero



820 860 880 970 980
TX760B TX860B
TX870B TX970B

801 803 805 807 813 815 817 821 823 825 831 833 841 843 845 851 853 855 921
922 923 931 932

46016C02.1

6199042M3

1

Jan-06

Cab
Cabine
Cabina

Door
Porte
Puerta

C-46016-02.1-A

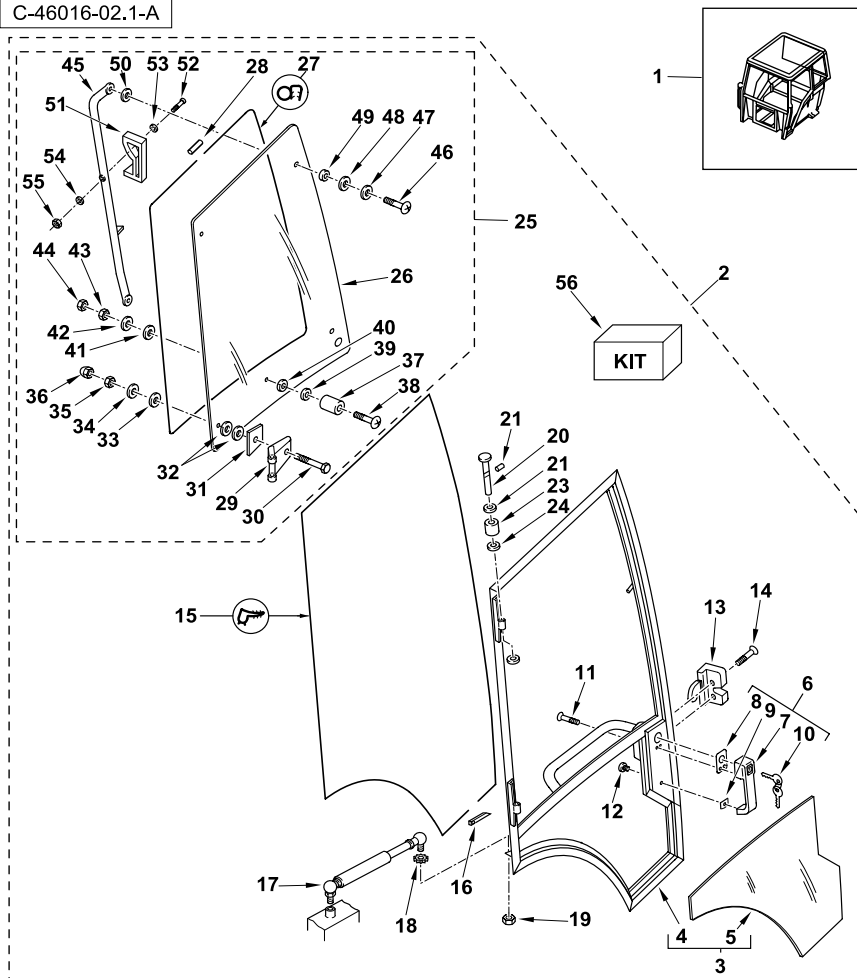

37	3512363M1	25		1	Retainer	Dispositif de retenue	Fijación
38	6106471M1	25	M6 x 30	1	Screw	Vis	Tornillo
39	6099248M1	25		1	Washer, Rubber	Rondelle élastique	Arandela elástica
40	6099406M1	25		1	Spacer	Entretoise	Traviesa
41	3512561M1	25	13,5 x 35 x 3	1	Washer, Rubber	Rondelle élastique	Arandela elástica
42	3512435M1	25	M6	1	Washer	Rondelle	Arandela
43	1441500X1	25	M6	1	Nut, Lock	Écrou de blocage	Tuerca de retención
44	3512502M1	25		1	Cap	Chapeau	Sombbrero
45	6099422M91	25		1	Handle Assy	Ensemble de poignée	Empuñadura, Conj.
46	3512392M1	25	M6 x 25	2	Screw	Vis	Tornillo
47	3512435M1	25	M6	2	Washer	Rondelle	Arandela
48	3512561M1	25	13,5 x 35 x 3	2	Washer, Rubber	Rondelle élastique	Arandela elástica
49	3512450M1	25	6,2 x 12,5 x 10	2	Spacer	Entretoise	Traviesa
50	3512561M1	25	13,5 x 35 x 3	2	Washer, Rubber	Rondelle élastique	Arandela elástica
51	6099423M1	25		1	Handle	Poignée	Asa
52	391884X1	25	M6 x 50	1	Screw	Vis	Tornillo
53	6106467M1	25	6,4 x 18 x 2 mm	1	Washer	Rondelle	Arandela
54	1441500X1	25	M6	1	Nut, Lock	Écrou de blocage	Tuerca de retención
55	3512502M1	25		1	Cap	Chapeau	Sombbrero
56	3621392M91	2		1	Kit, Adhesive	Jeu d'adhésifs	Empaque de cola



820 860 880 970 980
TX760B TX860B
TX870B TX970B

801 803 805 807 813 815 817 821 823 825 831 833 841 843 845 851 853 855 921
922 923 931 932

46016C02.1

6199042M3

1

Jan-06

Cab
Cabine
Cabina

Frame
Bâti
Bastidor

C-46015-01.1-B

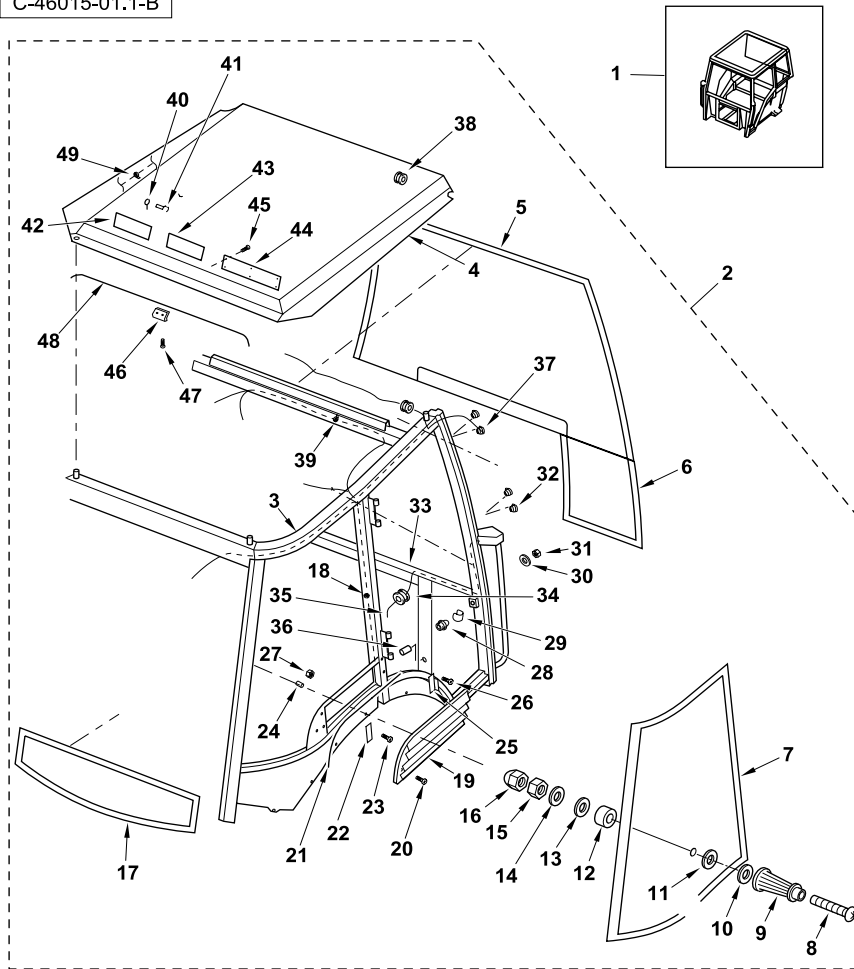

1	6099759M93G Y02		1	Cab Assy	Ensemble de cabine	Cabina, Conj.
2	6099760M93	1	1	Frame Assy	Ensemble de bâti	Bastidor, Conj.
3		2	1	Frame	Bâti	Bastidor
4		2	1	Roof	Toit	Techo
5	6099916M1	2	1	Windshield	Pare-brise	Parabrisas
6	6099902M1	2	1	Glass	Vitre	Cristal
6	6099903M1	2	1	Glass	Vitre	Cristal
7	6099910M1	2	1	Glass	Vitre	Cristal
7	6099911M1	2	1	Glass	Vitre	Cristal
8	6099920M1	2	1	Holder	Porte-injecteur	Retén
9	6099459M1	2	2	Screw	Vis	Tornillo
10	3512435M1	2	2	Washer	Rondelle	Arandela
11	6099245M1	2	2	Washer, Rubber	Rondelle élastique	Arandela elástica
12	6099406M1	2	2	Spacer	Entretoise	Traviesa
13	6099245M1	2	2	Washer, Rubber	Rondelle élastique	Arandela elástica
14	3512435M1	2	2	Washer	Rondelle	Arandela
15	1441500X1	2	2	Nut, Lock	Écrou de blocage	Tuerca de retención
16	3512502M1	2	1	Cap	Chapeau	Sombbrero
17	6099909M1	2	1	Glass	Vitre	Cristal
18	6099460M1	2	6	Tie, Cable	Attache câble	Enlace de Cable
19	6099528M1	2	1	Grating	Grille	Rejilla
20	3512494M1	2	1	Screw	Vis	Tornillo
21	6102154M1	2	1	Gasket, Mounting	Joint d'étanchéité	Junta de estanqueidad
22	6099229M1	2	1	Mount	Support de fixation	Soporte de fijación
23	3512494M1	2	2	Screw	Vis	Tornillo
24	6106468M1	2	2	Nut	Écrou	Tuerca
25	6099222M1	2	1	Bracket	Patte de fixation	Pata de fijación
26	3512494M1	2	2	Screw	Vis	Tornillo
27	6106468M1	2	2	Nut	Écrou	Tuerca
28	3512340M1	2	2	Plate, Catch	Gâche	Placa de cierre
29	3512441M1	2	2	Guard	Protecteur	Protector
30	3512620M1	2	2	Washer	Rondelle	Arandela
31	3008865X1	2	2	Nut	Écrou	Tuerca
32	6099408M1	2	4	Plug	Bouchon	Tapón
33	3512805M1	2	2	Stop	Butée	Tope
34	6099579M1	2	3	Grommet	Passe-fil	Pasa cable
35	6101354M91	2	2	Harness	Faisceau	Haz
36	6106469M1	2	2	Nut	Écrou	Tuerca
37	6099408M1	2	4	Plug	Bouchon	Tapón
38	6099579M1	2	3	Grommet	Passe-fil	Pasa cable
39	6099460M1	2	3	Tie, Cable	Attache câble	Enlace de Cable
40	6099407M1	2	1	Hook	Crochet	Gancho
41	6099458M1	2	1	Rivet	Rivet	Remache



820 860 880 970 980
TX760B TX860B
TX870B TX970B

801 803 805 807 809 811 813 815 817 821 823 825 831 833 841 843 845 851 853
855 921 922 923 931 932

46015C01.1

6199042M3

1

Jan-06

Cab
Cabine
Cabina

Frame
Bâti
Bastidor

C-46015-01.1-B

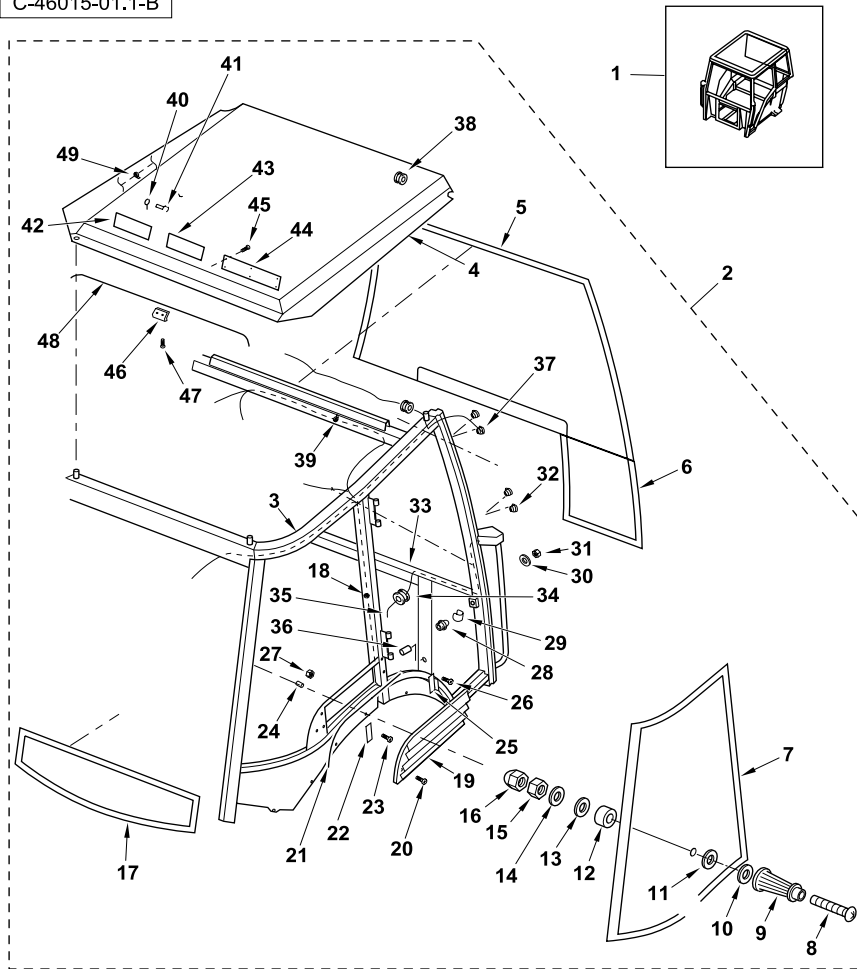

42	6002676M1	2		1	Plate, Warning	Plaque avertissement	Placa de advertencia
43		2	Ref. 2	1	Plate, Approval	Plaque homologation	Placa homologación
44		2	Ref. 2	1	Plate, Identity	Plaque d'identité	Placa de identidad
45	519566M1	2		12	Rivet	Rivet	Remache
46	3512244M1	2		1	Fastener	Attache	Eganche
47	3512494M1	2	M6 x 12	2	Screw	Vis	Tornillo
48	6099463M1	2	1100 mm	1	Strip, Sealing	Bande d'étanchéité	Banda estanqueidad
49	6099460M1	2		5	Tie, Cable	Attache câble	Enlace de Cable



820 860 880 970 980
TX760B TX860B
TX870B TX970B

801 803 805 807 809 811 813 815 817 821 823 825 831 833 841 843 845 851 853
855 921 922 923 931 932

46015C01.1

6199042M3

1

Jan-06

Cab
Cabine
Cabina

Frame
Bâti
Bastidor

C-46016-01.1-B

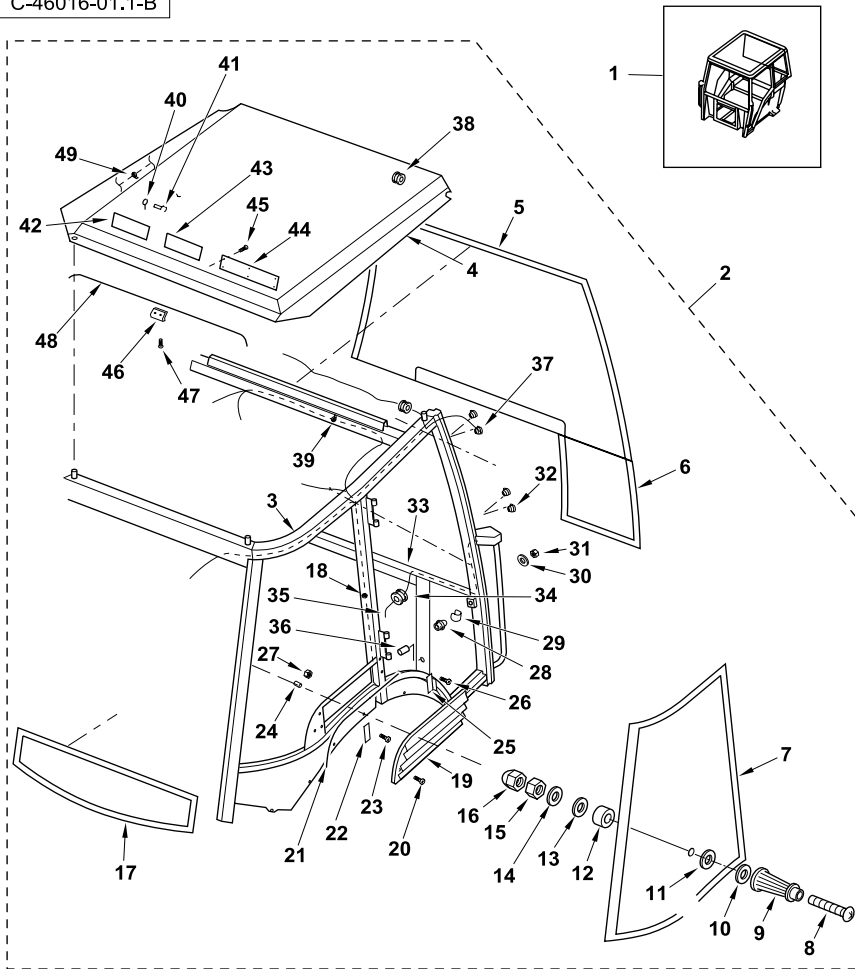

1	6099764M92Y02			1	Cab Assy	Ensemble de cabine	Cabina, Conj.
2	6099760M93	1		1	Frame Assy	Ensemble de bâti	Bastidor, Conj.
3		2	▶ Ref. 2	1	Frame	Bâti	Bastidor
4		2	▶ Ref. 2	1	Roof	Toit	Techo
5	6099916M1	2		1	Windshield	Pare-brise	Parabrisas
6	6099902M1	2	◀	1	Glass	Vitre	Cristal
6	6099903M1	2	▶	1	Glass	Vitre	Cristal
7	6099910M1	2	◀	1	Glass	Vitre	Cristal
7	6099911M1	2	▶	1	Glass	Vitre	Cristal
8	6099920M1	2		1	Holder	Porte-injecteur	Retén
9	6099459M1	2	M6 x 50	2	Screw	Vis	Tornillo
10	3512435M1	2	M6	2	Washer	Rondelle	Arandela
11	6099245M1	2		2	Washer, Rubber	Rondelle élastique	Arandela elástica
12	6099406M1	2		2	Spacer	Entretoise	Traviesa
13	6099245M1	2		2	Washer, Rubber	Rondelle élastique	Arandela elástica
14	3512435M1	2	M6	2	Washer	Rondelle	Arandela
15	1441500X1	2	M6	2	Nut, Lock	Écrou de blocage	Tuerca de retención
16	3512502M1	2		1	Cap	Chapeau	Sombbrero
17	6099909M1	2		1	Glass	Vitre	Cristal
18	6099460M1	2		6	Tie, Cable	Attache câble	Enlace de Cable
19	6099528M1	2		1	Grating	Grille	Rejilla
20	3512494M1	2	M6 x 12	1	Screw	Vis	Tornillo
21	6102154M1	2		1	Gasket, Mounting	Joint d'étanchéité	Junta de estanqueidad
22	6099229M1	2		1	Mount	Support de fixation	Soporte de fijación
23	3512494M1	2	M6 x 12	2	Screw	Vis	Tornillo
24	6106468M1	2	M5	2	Nut	Écrou	Tuerca
25	6099222M1	2		1	Bracket	Patte de fixation	Pata de fijación
26	3512494M1	2	M6 x 12	2	Screw	Vis	Tornillo
27	6106468M1	2	M5	2	Nut	Écrou	Tuerca
28	3512340M1	2		2	Plate, Catch	Gâche	Placa de cierre
29	3512441M1	2		2	Guard	Protecteur	Protector
30	3512620M1	2		2	Washer	Rondelle	Arandela
31	3008865X1	2	M12	2	Nut	Écrou	Tuerca
32	6099408M1	2		4	Plug	Bouchon	Tapón
33	3512805M1	2		2	Stop	Butée	Tope
34	6099579M1	2		3	Grommet	Passe-fil	Pasa cable
35	6101354M91	2		2	Harness	Faisceau	Haz
36	6106469M1	2	M8	2	Nut	Écrou	Tuerca
37	6099408M1	2		4	Plug	Bouchon	Tapón
38	6099579M1	2		3	Grommet	Passe-fil	Pasa cable
39	6099460M1	2		3	Tie, Cable	Attache câble	Enlace de Cable
40	6099407M1	2		1	Hook	Crochet	Gancho
41	6099458M1	2	4 x 16,9 mm	1	Rivet	Rivet	Remache



820 860 880 970 980
TX760B TX860B
TX870B TX970B

801 803 805 807 813 815 817 821 823 825 831 833 841 843 845 851 853 855 921
922 923 931 932

46016C01.1

6199042M3

1

Jan-06

Cab
Cabine
Cabina

Frame
Bâti
Bastidor

C-46016-01.1-B

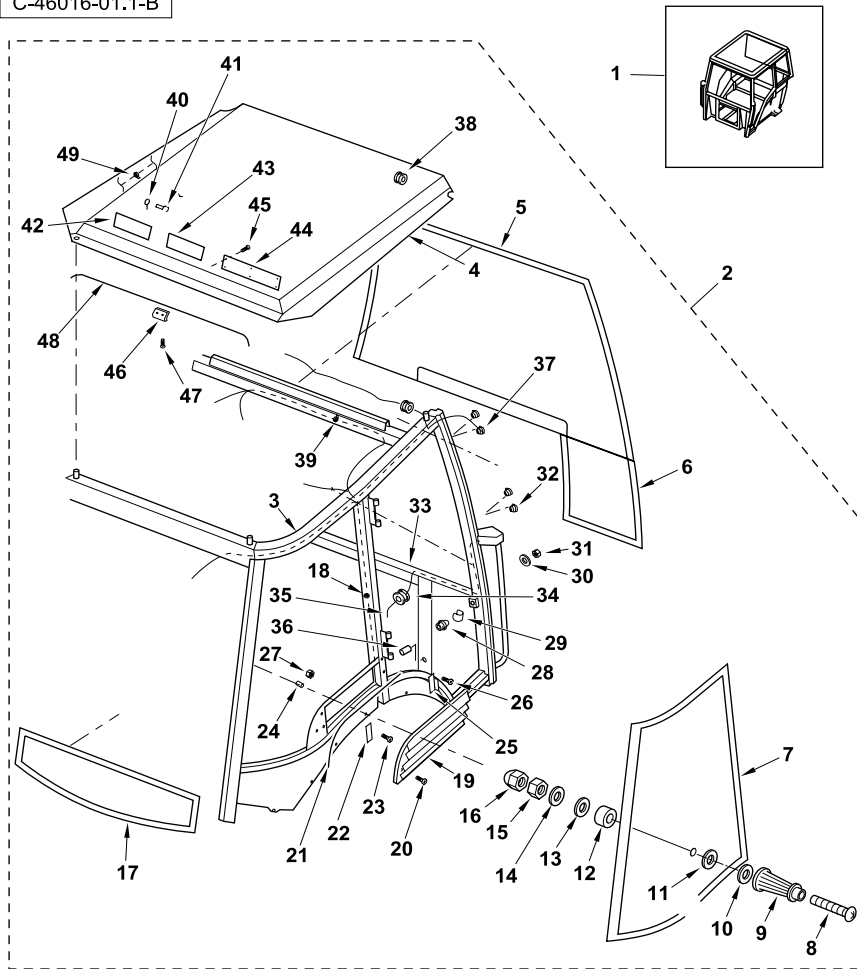

42	6002676M1	2		1	Plate, Warning	Plaque avertissement	Placa de advertencia
43		2	Ref. 2	1	Plate, Approval	Plaque homologation	Placa homologación
44		2	Ref. 2	1	Plate, Identity	Plaque d'identité	Placa de identidad
45	519566M1	2		12	Rivet	Rivet	Remache
46	3512244M1	2		1	Fastener	Attache	Eganche
47	3512494M1	2	M6 x 12	2	Screw	Vis	Tornillo
48	6099463M1	2	1100 mm	1	Strip, Sealing	Bande d'étanchéité	Banda estanqueidad
49	6099460M1	2		5	Tie, Cable	Attache câble	Enlace de Cable



820 860 880 970 980
TX760B TX860B
TX870B TX970B

801 803 805 807 813 815 817 821 823 825 831 833 841 843 845 851 853 855 921
922 923 931 932

46016C01.1

6199042M3

1

Jan-06

Cab
Cabine
Cabina

Front Worklight
Phare de Travail Avant
Luz de trabajo delanteras

C-46015-05.1-A

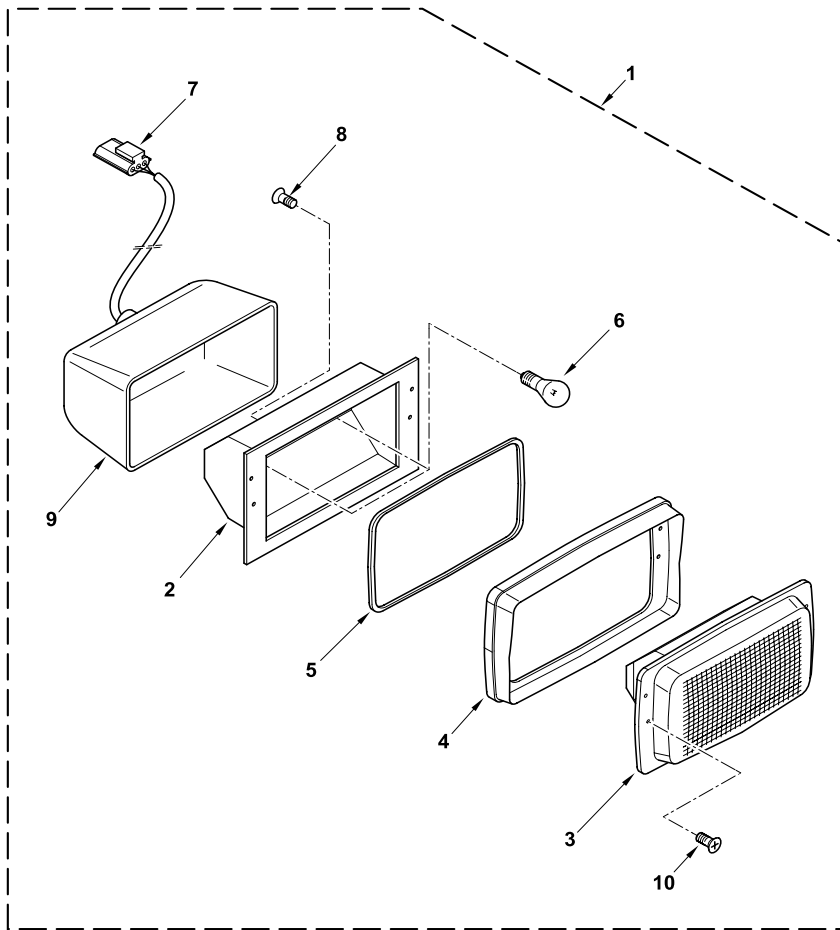

1	6101560M91	👁️ [46015C04.1 4] Front	1	Lamp Assy, Work	Ensemble phare travail	Faro de trabajo, Conj.
2		➡️ Ref. 1	1	Reflector	Catadioptré	Reflector
3	6190753M91		1	Lens	Lentille	Lente
4	6190754M91		1	Rim	Jante	Corona
5		➡️ Ref. 1	1	Seal	Joint	Junta
6	3523689M1	12V - 55W	2	Bulb	Lampe	Lámpara
7	6190755M91		1	Harness	Faisceau	Haz
8		➡️ Ref. 1	1	Screw	Vis	Tornillo
9		➡️ Ref. 1	1	Body	Corps	Cuerpo
10		➡️ Ref. 1	2	Screw	Vis	Tornillo



820 860 880 970 980
TX760B TX860B
TX870B TX970B

801 803 805 807 809 811 813 815 817 821 823 825 831 833 841 843 845 851 853
855 921 922 923 931 932

46015C05.1

6199042M3

1

Jan-06

Cab
Cabine
Cabina

Front Worklight
Phare de Travail Avant
Luz de trabajo delanteras

C-46016-05.1-A

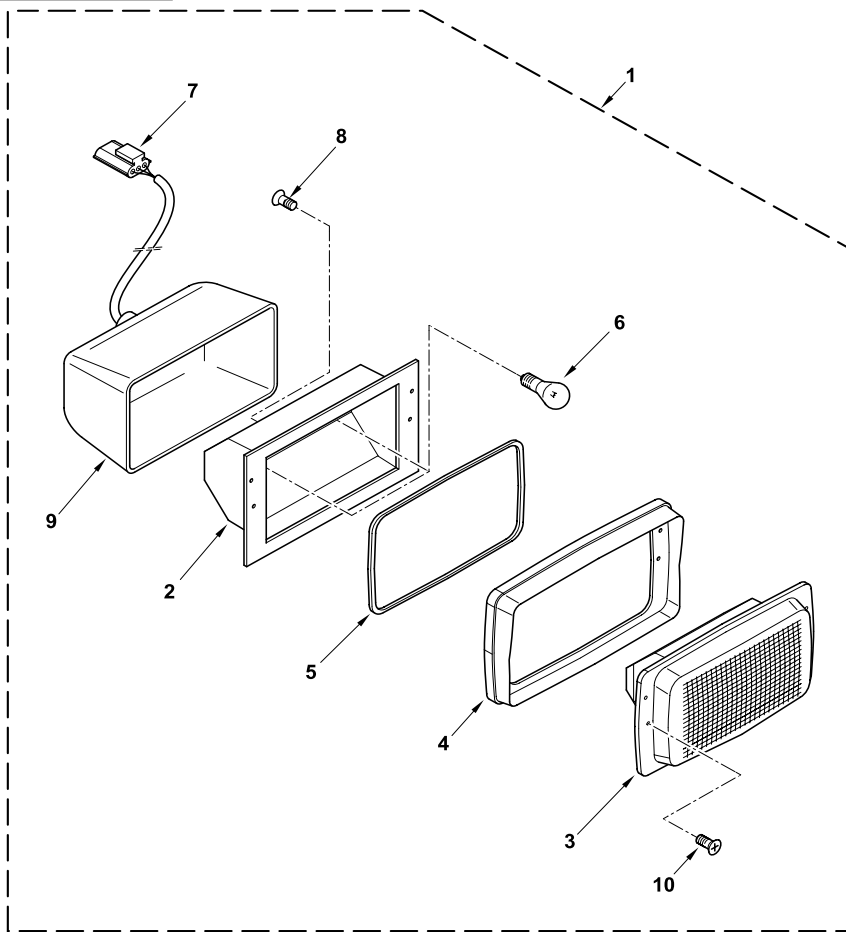

1	6101560M91	👁️ [46016C04.1 4] Front	1	Lamp Assy, Work	Ensemble phare travail	Faro de trabajo, Conj.
2		➡️ Ref. 1	1	Reflector	Catadioptre	Reflector
3	6190753M91		1	Lens	Lentille	Lente
4	6190754M91		1	Rim	Jante	Corona
5		➡️ Ref. 1	1	Seal	Joint	Junta
6	3523689M1	12V - 55W	2	Bulb	Lampe	Lámpara
7	6190755M91		1	Harness	Faisceau	Haz
8		➡️ Ref. 1	1	Screw	Vis	Tornillo
9		➡️ Ref. 1	1	Body	Corps	Cuerpo
10		➡️ Ref. 1	2	Screw	Vis	Tornillo



820 860 880 970 980
TX760B TX860B
TX870B TX970B

801 803 805 807 813 815 817 821 823 825 831 833 841 843 845 851 853 855 921
922 923 931 932

46016C05.1

6199042M3

1

Jan-06

Cab
Cabine
Cabinas

Inner Roof
Toit Intérieur
Techo interior

C-46015-07.1-A

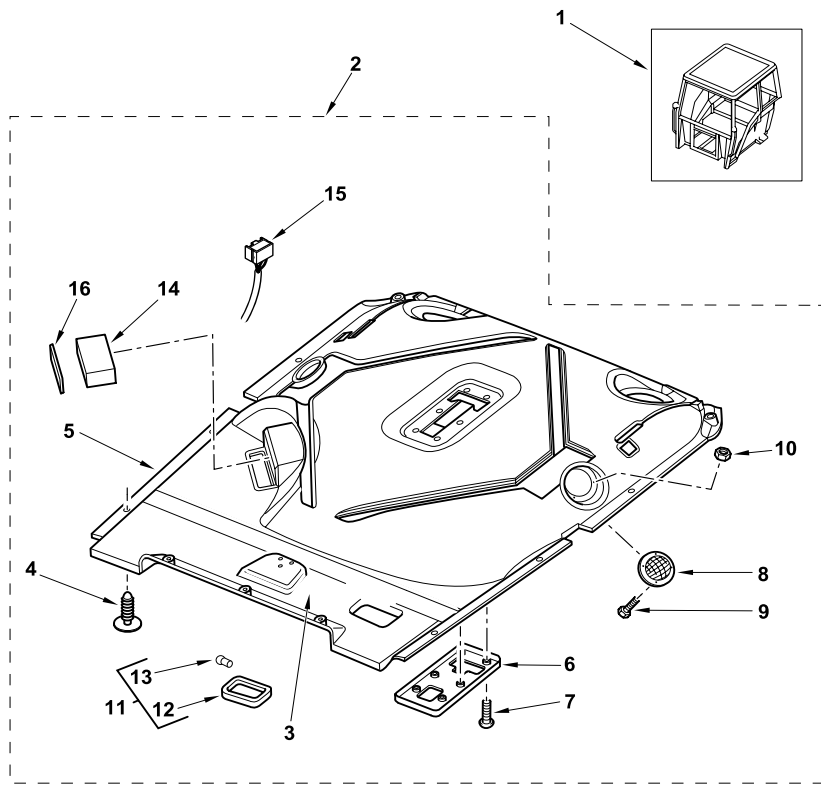

1	6099759M93G Y02			1	Cab Assy	Ensemble de cabine	Cabina, Conj.
2	6099405M93	1		1	Roof Assy	Ensemble de toit	Techo, Conj.
3	6099525M2	2		1	Lining	Garniture	Guarnición
4	6102077M1	2		14	Fastener	Attache	Enganche
5	6099461M1	2		2	Profile	Profilé	Perfil
6	6099247M1	2		1	Cover	Cache	Tapa
7	3512617M1	2	M5 x 12	6	Screw	Vis	Tornillo
8	3516210M1	2		2	Grille	Grille	Rejilla
9	6099448M1	2	4,8 x 25 mm	8	Screw	Vis	Tornillo
10	3512511M1	2	M5	8	Nut	Écrou	Tuerca
11	3516209M92	2		1	Lamp, Interior	Éclairage intérieur	Iluminación interior
12		11	Ref. 11	1	Lamp	Feu	Luz
13	3523441M1	11	12V - 10W	1	Bulb	Lampe	Lámpara
14	6109772M1	2		1	Housing	Carter	Cárter
15	6109777M91	2	Radio	1	Harness Assy	Ensemble de faisceau	Haz, Conj.
16	6109775M1	2		1	Cover	Cache	Tapa



820 860 880 970 980
TX760B TX860B
TX870B TX970B

801 803 805 807 809 811 813 815 817 821 823 825 831 833 841 843 845 851 853
855 921 922 923 931 932

46015C07.1

6199042M3

1

Jan-06

Cab
Cabine
Cabina

Inner Roof
Toit Intérieur
Techo interior

C-46016-07.1-A

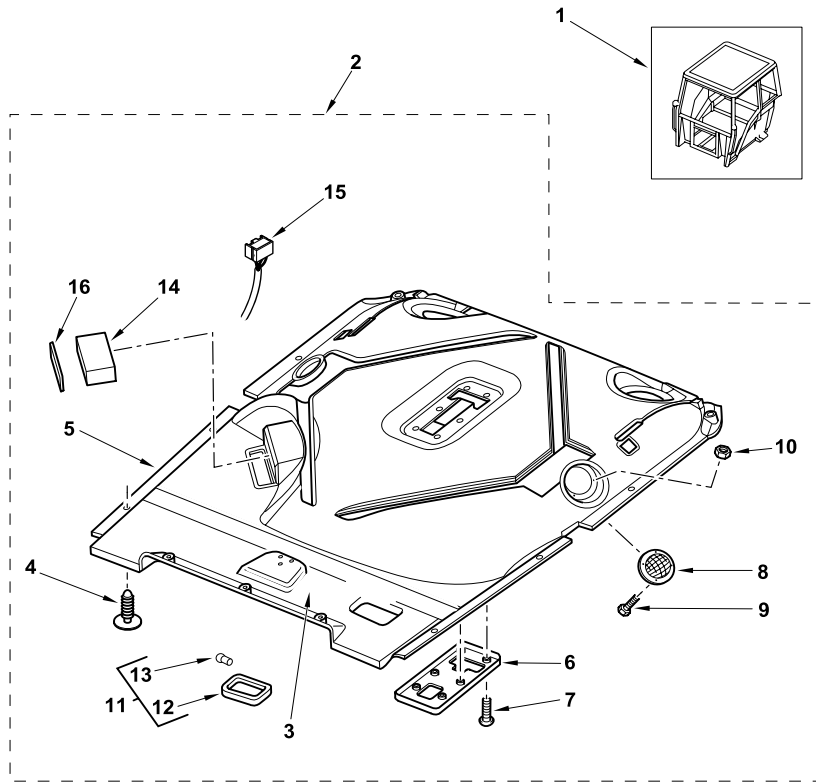

1	6099764M92Y 02			1	Cab Assy	Ensemble de cabine	Cabina, Conj.
2	6099405M93	1		1	Roof Assy	Ensemble de toit	Techo, Conj.
3	6099525M2	2		1	Lining	Garniture	Guarnición
4	6102077M1	2		14	Fastener	Attache	Enganche
5	6099461M1	2		2	Profile	Profilé	Perfil
6	6099247M1	2		1	Cover	Cache	Tapa
7	3512617M1	2	M5 x 12	6	Screw	Vis	Tornillo
8	3516210M1	2		2	Grille	Grille	Rejilla
9	6099448M1	2	4,8 x 25 mm	8	Screw	Vis	Tornillo
10	3512511M1	2	M5	8	Nut	Écrou	Tuerca
11	3516209M92	2		1	Lamp, Interior	Éclairage intérieur	Iluminación interior
12		11	Ref. 11	1	Lamp	Feu	Luz
13	3523441M1	11	12V - 10W	1	Bulb	Lampe	Lámpara
14	6109772M1	2		1	Housing	Carter	Cárter
15	6109777M91	2	Radio	1	Harness Assy	Ensemble de faisceau	Haz, Conj.
16	6109775M1	2		1	Cover	Cache	Tapa



820 860 880 970 980
TX760B TX860B
TX870B TX970B

801 803 805 807 813 815 817 821 823 825 831 833 841 843 845 851 853 855 921
922 923 931 932

46016C07.1

6199042M3

1

Jan-06

Cab
Cabine
Cabina

Outer Roof
Toit Extérieur
Techo exterior

C-46015-04.1-A

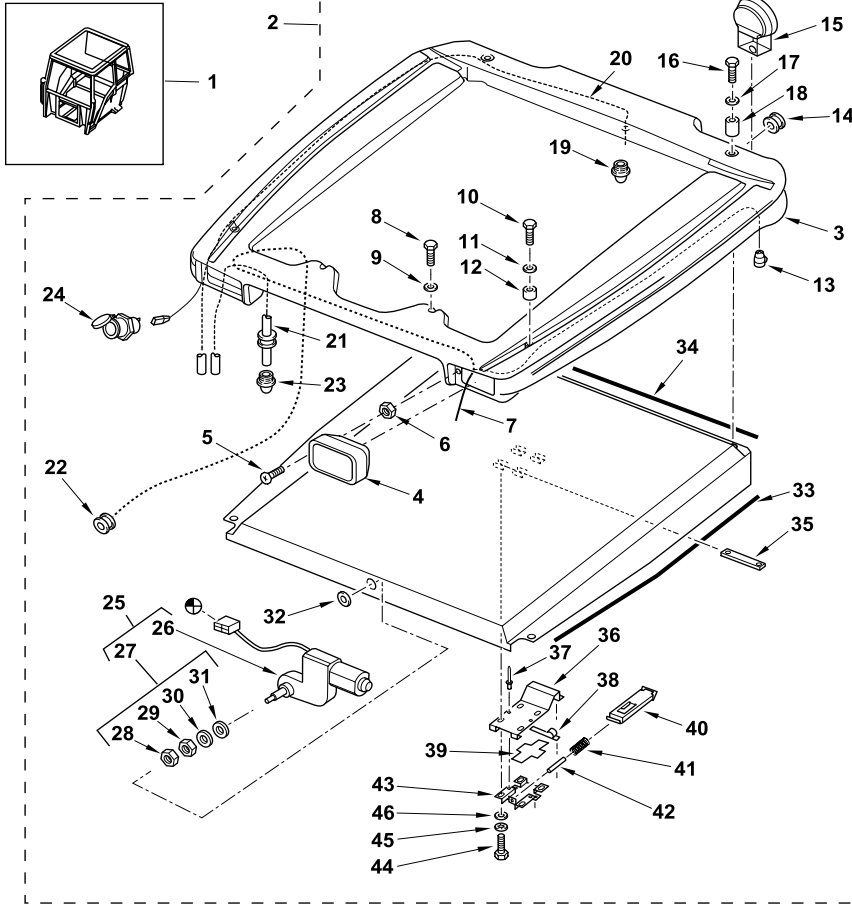

1	6099759M93G Y02			1	Cab Assy	Ensemble de cabine	Cabina, Conj.
2	6099425M93	1		1	Roof Assy	Ensemble de toit	Techo, Conj.
3	6099551M2	2	Grey	1	Roof	Toit	Techo
4	6101560M91	2	☉ [46015C05.1 1] Front	2	Lamp Assy, Work	Ensemble phare travail	Faro de trabajo, Conj.
5	6099456M1	2		4	Screw	Vis	Tornillo
6	6101590M1	2	M4	4	Nut, U	Écrou en U	Tuerca en U
7	6108826M91	2		1	Harness Assy	Ensemble de faisceau	Haz, Conj.
8	3512555M1	2	M5 x 10	2	Screw	Vis	Tornillo
9	6099561M1	2		2	Washer	Rondelle	Arandela
10	3009505X1	2	M12 x 25	2	Bolt	Boulon	Perno
11	6099562M1	2		2	Washer	Rondelle	Arandela
12	6099563M1	2		2	Spacer	Entretoise	Traviesa
13	3517621M91	2		1	Socket	Prise de courant	Toma de corriente
14	6099447M1	2	22 x 28 x 4 mm	2	Grommet	Passe-fil	Pasa cable
15	6110033M91	2	☉ [46015C06.1 1]	2	Lamp Assy, Work	Ensemble phare travail	Faro de trabajo, Conj.
16	3009509X1	2	M12 x 45	2	Screw	Vis	Tornillo
17	6099562M1	2		2	Washer	Rondelle	Arandela
18	6099564M1	2		2	Spacer	Entretoise	Traviesa
19	3512320M1	2		1	Diffuser	Diffuseur	Difusor
20	3522641M4	2	4250 mm	1	Hose	Flexible	Tubo flexible
21	3522640M3	2	3000 mm	1	Hose	Flexible	Tubo flexible
22	6099457M1	2	20 x 26 mm	1	Grommet	Passe-fil	Pasa cable
23	3512320M1	2		1	Diffuser	Diffuseur	Difusor
24	3517621M91	2		1	Socket	Prise de courant	Toma de corriente
25	3504311M91	2		1	Motor, Wiper	Moteur d'essuie-glace	Motor limpiaparabr.
26		25	➡ Ref. 25	1	Motor, Wiper	Moteur d'essuie-glace	Motor limpiaparabr.
27	3523336M91	25		1	Kit, Parts	Lot de pièces	Juego de piezas
28		27	➡ Ref. 27	1	Cap	Chapeau	Sombbrero
29		27	➡ Ref. 27	1	Nut	Écrou	Tuerca
30		27	➡ Ref. 27	1	Washer	Rondelle	Arandela
31		27	➡ Ref. 27	1	Washer	Rondelle	Arandela
32	3019881X1	2	M16	1	Washer, Lock	Rondelle de blocage	Arandela de freno
33	6099454M1	2	1200 mm	2	Seal	Joint	Junta
34	6099455M1	2	1100 mm	1	Seal	Joint	Junta
35	3512591M1	2		2	Plate	Plaque	Placa
36	6099592M1	2		1	Mount	Support de fixation	Soporte de fijación
37	6099595M1	2	4 x 12 mm	2	Rivet	Rivet	Remache
38	3512475M1	2		1	Gasket, Mounting	Joint d'étanchéité	Junta de estanqueidad
39	6099265M1	2	Plastic	1	Spacer	Entretoise	Traviesa
40	6099593M1	2		1	Latching Device	Verrou	Cerrojo
41	6099594M1	2		1	Spring	Ressort	Muelle
42	1442357X1	2		1	Pin, Roll	Goupille élastique	Pasador elástico



820 860 880 970 980
TX760B TX860B
TX870B TX970B

801 803 805 807 809 811 813 815 817 821 823 825 831 833 841 843 845 851 853
855 921 922 923 931 932

46015C04.1

6199042M3

1

Jan-06

Cab
Cabine
Cabina

Outer Roof
Toit Extérieur
Techo exterior

C-46015-04.1-A

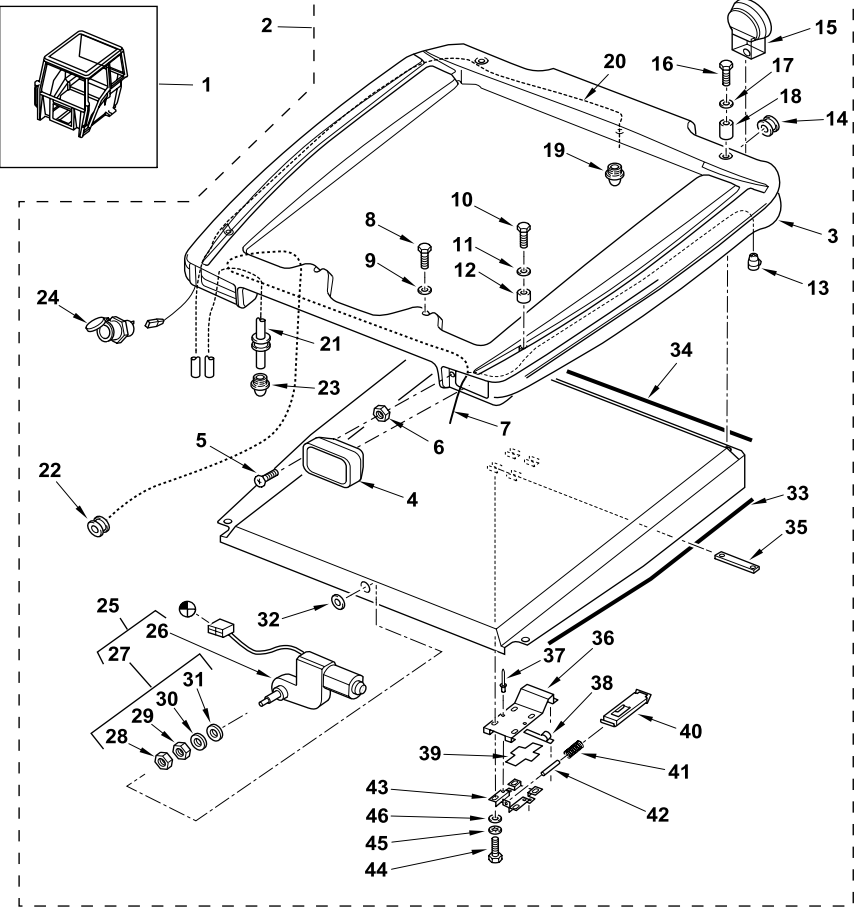

43	6099596M1	2		1	Bracket	Patte de fixation	Pata de fijación
44	339123X1	2	M8 x 20	4	Bolt	Boulon	Perno
45	391025X1	2	M8	4	Washer, Lock	Rondelle de blocage	Arandela de freno
46	390972X1	2	M8	4	Washer	Rondelle	Arandela



820 860 880 970 980
TX760B TX860B
TX870B TX970B

801 803 805 807 809 811 813 815 817 821 823 825 831 833 841 843 845 851 853
855 921 922 923 931 932

46015C04.1

6199042M3

1

Jan-06

Cab
Cabine
Cabina

Outer Roof
Toit Extérieur
Techo exterior

C-46016-04.1-A

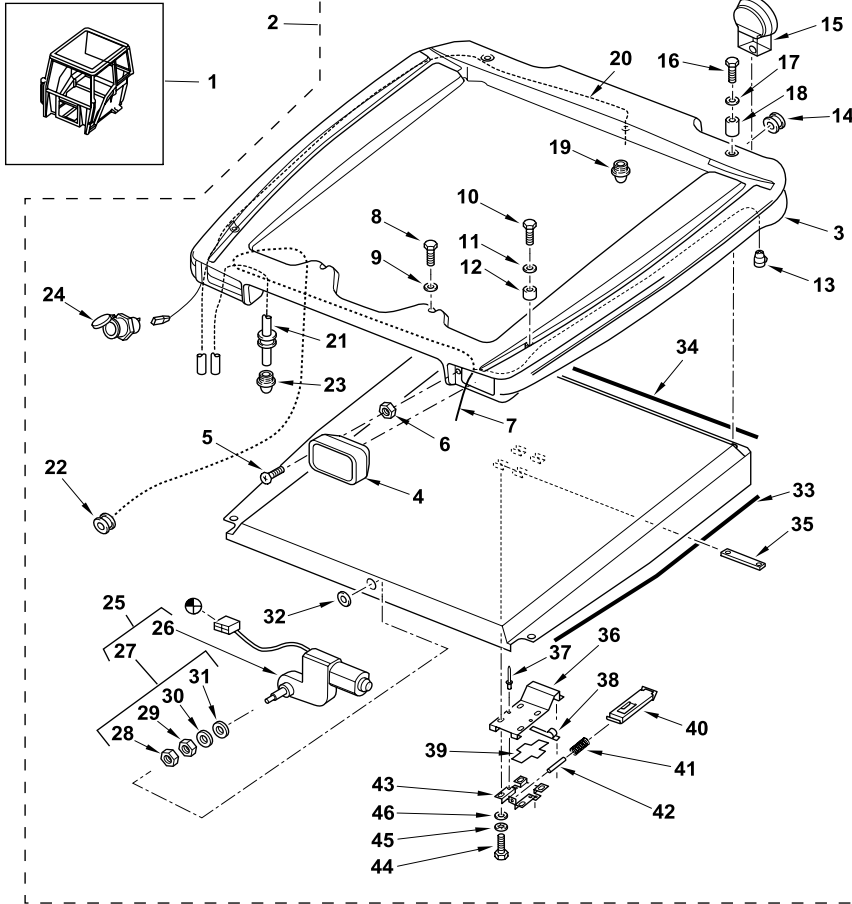

1	6099764M92Y Q2			1	Cab Assy	Ensemble de cabine	Cabina, Conj.
2	6099465M91	1		1	Roof Assy	Ensemble de toit	Techo, Conj.
3	6099507M1	2	Yellow	1	Roof	Toit	Techo
4	6101560M91	2	☉ [46016C05.1 1] Front	2	Lamp Assy, Work	Ensemble phare travail	Faro de trabajo, Conj.
5	6099456M1	2		4	Screw	Vis	Tornillo
6	6101590M1	2	M4	4	Nut, U	Écrou en U	Tuerca en U
7	6108826M91	2		1	Harness Assy	Ensemble de faisceau	Haz, Conj.
8	3512555M1	2	M5 x 10	2	Screw	Vis	Tornillo
9	6099561M1	2		2	Washer	Rondelle	Arandela
10	3009505X1	2	M12 x 25	2	Bolt	Boulon	Perno
11	6099562M1	2		2	Washer	Rondelle	Arandela
12	6099563M1	2		2	Spacer	Entretoise	Traviesa
13	3517621M91	2		1	Socket	Prise de courant	Toma de corriente
14	6099447M1	2	22 x 28 x 4 mm	2	Grommet	Passe-fil	Pasa cable
15	6110033M91	2	☉ [46016C06.1 1]	2	Lamp Assy, Work	Ensemble phare travail	Faro de trabajo, Conj.
16	3009509X1	2	M12 x 45	2	Screw	Vis	Tornillo
17	6099562M1	2		2	Washer	Rondelle	Arandela
18	6099564M1	2		2	Spacer	Entretoise	Traviesa
19	3512320M1	2		1	Diffuser	Diffuseur	Difusor
20	3522641M4	2	4250 mm	1	Hose	Flexible	Tubo flexible
21	3522640M3	2	3000 mm	1	Hose	Flexible	Tubo flexible
22	6099457M1	2	20 x 26 mm	1	Grommet	Passe-fil	Pasa cable
23	3512320M1	2		1	Diffuser	Diffuseur	Difusor
24	3517621M91	2		1	Socket	Prise de courant	Toma de corriente
25	3504311M91	2		1	Motor, Wiper	Moteur d'essuie-glace	Motor limpiaparabr.
26		25	➡ Ref. 25	1	Motor, Wiper	Moteur d'essuie-glace	Motor limpiaparabr.
27	3523336M91	25		1	Kit, Parts	Lot de pièces	Juego de piezas
28		27	➡ Ref. 27	1	Cap	Chapeau	Sombbrero
29		27	➡ Ref. 27	1	Nut	Écrou	Tuerca
30		27	➡ Ref. 27	1	Washer	Rondelle	Arandela
31		27	➡ Ref. 27	1	Washer	Rondelle	Arandela
32	3019881X1	2	M16	1	Washer, Lock	Rondelle de blocage	Arandela de freno
33	6099454M1	2	1200 mm	2	Seal	Joint	Junta
34	6099455M1	2	1100 mm	1	Seal	Joint	Junta
35	3512591M1	2		2	Plate	Plaque	Placa
36	6099592M1	2		1	Mount	Support de fixation	Soporte de fijación
37	6099595M1	2	4 x 12 mm	2	Rivet	Rivet	Remache
38	3512475M1	2		1	Gasket, Mounting	Joint d'étanchéité	Junta de estanqueidad
39	6099265M1	2	Plastic	1	Spacer	Entretoise	Traviesa
40	6099593M1	2		1	Latching Device	Verrou	Cerrojo
41	6099594M1	2		1	Spring	Ressort	Muelle
42	1442357X1	2		1	Pin, Roll	Goupille élastique	Pasador elástico



820 860 880 970 980
TX760B TX860B
TX870B TX970B

801 803 805 807 813 815 817 821 823 825 831 833 841 843 845 851 853 855 921
922 923 931 932

46016C04.1

6199042M3

1

Jan-06

Cab
Cabine
Cabina

Outer Roof
Toit Extérieur
Techo exterior

C-46016-04.1-A

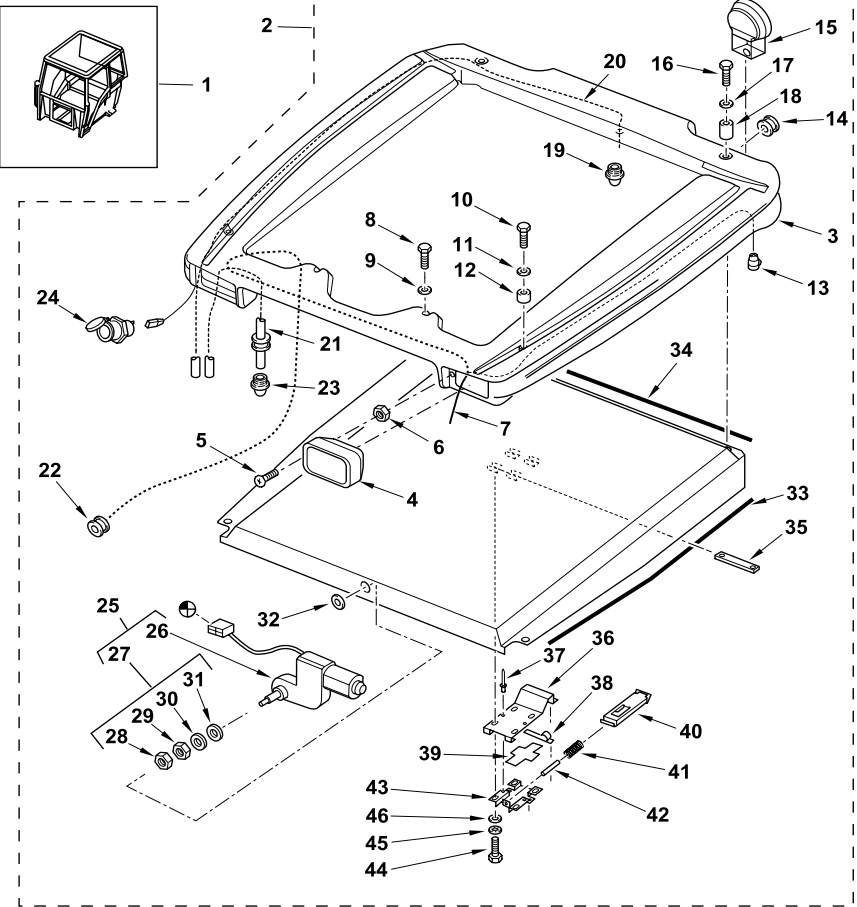

43	6099596M1	2		1	Bracket	Patte de fixation	Pata de fijación
44	339123X1	2	M8 x 20	4	Bolt	Boulon	Perno
45	391025X1	2	M8	4	Washer, Lock	Rondelle de blocage	Arandela de freno
46	390972X1	2	M8	4	Washer	Rondelle	Arandela



820 860 880 970 980
TX760B TX860B
TX870B TX970B

801 803 805 807 813 815 817 821 823 825 831 833 841 843 845 851 853 855 921
922 923 931 932

Cab
Cabine
Cabina

Rear Window
Lunette Arrière
Ventana trasera

C-46015-03.1-A

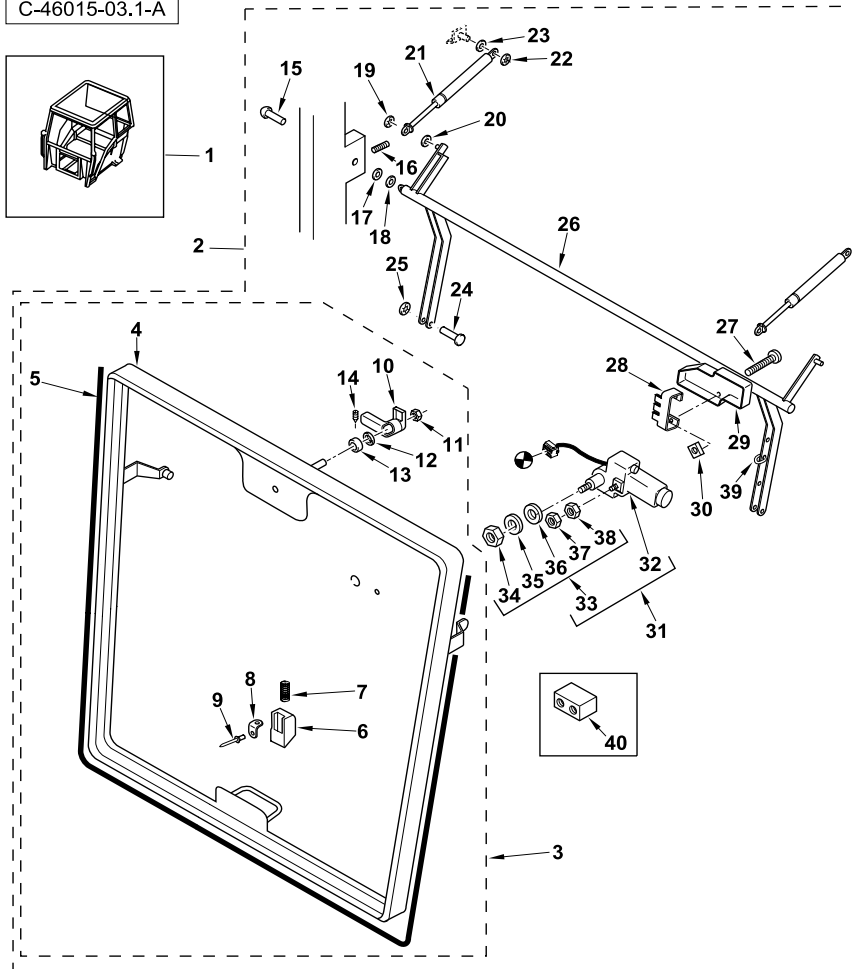

1	6099759M93G Y02			1	Cab Assy	Ensemble de cabine	Cabina, Conj.
2	6099762M91	1		1	Window Assy	Ensemble de fenêtre	Ventana, Conj.
3	6099765M91	2		1	Window Assy	Ensemble de fenêtre	Ventana, Conj.
4		3	➡ Ref. 3	1	Frame	Bâti	Bastidor
5	6099763M1	3		1	Seal	Joint	Junta
6	3512258M1	3		1	Plate, Catch	Gâche	Placa de cierre
7	3512255M1	3		1	Spring	Ressort	Muelle
8	3512260M1	3		1	Stop	Butée	Tope
9	522464M1	3		1	Rivet	Rivet	Remache
10	3512345M1	3		1	Handle	Poignée	Asa
11	3512513M1	3		1	Nut	Écrou	Tuerca
12	3512358M1	3		1	Spacer	Entretoise	Traviesa
13	3512357M1	3		1	Washer	Rondelle	Arandela
14	3512360M1	3	M4 x 10	1	Screw	Vis	Tornillo
15	6099249M1	2	9,5 x 50 mm	2	Pin	Axe	Pasador
16	3009420X1	2	M5 x 6	2	Screw	Vis	Tornillo
17	3512433M1	2		2	Washer	Rondelle	Arandela
18	3512619M1	2		2	Washer	Rondelle	Arandela
19	6099567M1	2		2	Ring, Retaining	Anneau de retenue	Anillo de retención
20	6099591M1	2	6,8 x 12 x 3 mm	2	Washer	Rondelle	Arandela
21	6099599M91	2		2	Gas Strut	Vérin à gaz	Gato de gas
22	6099567M1	2		2	Ring, Retaining	Anneau de retenue	Anillo de retención
23	3512450M1	2	6,2 x 12,5 x 10	2	Spacer	Entretoise	Traviesa
24	339229X1	2	M6 x 40	2	Screw	Vis	Tornillo
25	1441500X1	2	M6	2	Nut, Lock	Écrou de blocage	Tuerca de retención
26	6099610M91	2		1	Arm	Bras	Brazo
27	3512617M1	2	M5 x 12	2	Screw	Vis	Tornillo
28	3512257M1	2		1	Mount	Support de fixation	Soporte de fijación
29	6099468M1	2		1	Cover	Cache	Tapa
30	3512511M1	2	M5	2	Nut	Écrou	Tuerca
31	3512338M91	2		1	Motor, Wiper	Moteur d'essuie-glace	Motor limpiaparabr.
32		31	➡ Ref. 31	1	Motor, Wiper	Moteur d'essuie-glace	Motor limpiaparabr.
33	3523335M91	31		1	Kit, Parts	Lot de pièces	Juego de piezas
34		33	➡ Ref. 33	1	Nut	Écrou	Tuerca
35		33	➡ Ref. 33	1	Washer	Rondelle	Arandela
36		33	➡ Ref. 33	1	Washer	Rondelle	Arandela
37		33	➡ Ref. 33	1	Cap	Chapeau	Sombbrero
38		33	➡ Ref. 33	1	Nut	Écrou	Tuerca
39	6099460M1	2		3	Tie, Cable	Attache câble	Enlace de Cable
40	6099758M1	2		1	Spacer	Entretoise	Traviesa



820 860 880 970 980
TX760B TX860B
TX870B TX970B

801 803 805 807 809 811 813 815 817 821 823 825 831 833 841 843 845 851 853
855 921 922 923 931 932

46015C03.1

6199042M3

1

Jan-06

Cab
Cabine
Cabina

Rear Window
Lunette Arrière
Ventana trasera

C-46016-03.1-A

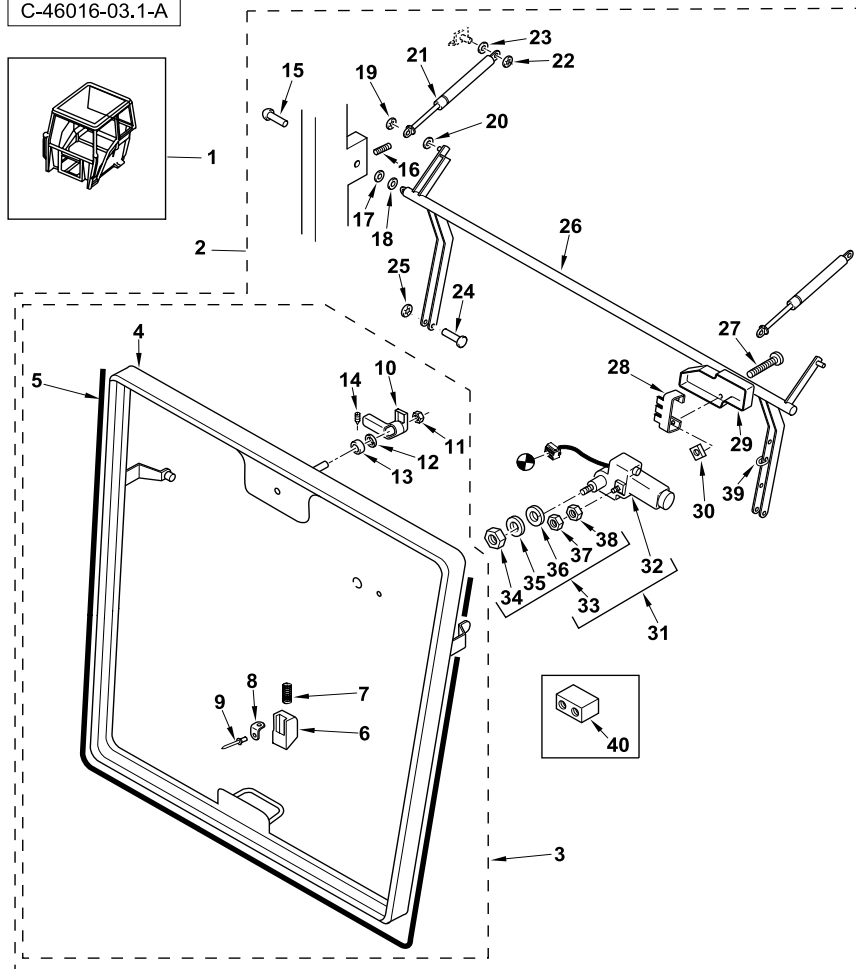

1	6099764M92Y 02			1	Cab Assy	Ensemble de cabine	Cabina, Conj.
2	6099762M91	1		1	Window Assy	Ensemble de fenêtre	Ventana, Conj.
3	6099765M91	2		1	Window Assy	Ensemble de fenêtre	Ventana, Conj.
4		3	➡ Ref. 3	1	Frame	Bâti	Bastidor
5	6099763M1	3		1	Seal	Joint	Junta
6	3512258M1	3		1	Plate, Catch	Gâche	Placa de cierre
7	3512255M1	3		1	Spring	Ressort	Muelle
8	3512260M1	3		1	Stop	Butée	Tope
9	522464M1	3		1	Rivet	Rivet	Remache
10	3512345M1	3		1	Handle	Poignée	Asa
11	3512513M1	3		1	Nut	Écrou	Tuerca
12	3512358M1	3		1	Spacer	Entretoise	Traviesa
13	3512357M1	3		1	Washer	Rondelle	Arandela
14	3512360M1	3	M4 x 10	1	Screw	Vis	Tornillo
15	6099249M1	2	9,5 x 50 mm	2	Pin	Axe	Pasador
16	3009420X1	2	M5 x 6	2	Screw	Vis	Tornillo
17	3512433M1	2		2	Washer	Rondelle	Arandela
18	3512619M1	2		2	Washer	Rondelle	Arandela
19	6099567M1	2		2	Ring, Retaining	Anneau de retenue	Anillo de retención
20	6099591M1	2	6,8 x 12 x 3 mm	2	Washer	Rondelle	Arandela
21	6099599M91	2		2	Gas Strut	Vérin à gaz	Gato de gas
22	6099567M1	2		2	Ring, Retaining	Anneau de retenue	Anillo de retención
23	3512450M1	2	6,2 x 12,5 x 10	2	Spacer	Entretoise	Traviesa
24	339229X1	2	M6 x 40	2	Screw	Vis	Tornillo
25	1441500X1	2	M6	2	Nut, Lock	Écrou de blocage	Tuerca de retención
26	6099610M91	2		1	Arm	Bras	Brazo
27	3512617M1	2	M5 x 12	2	Screw	Vis	Tornillo
28	3512257M1	2		1	Mount	Support de fixation	Soporte de fijación
29	6099468M1	2		1	Cover	Cache	Tapa
30	3512511M1	2	M5	2	Nut	Écrou	Tuerca
31	3512338M91	2		1	Motor, Wiper	Moteur d'essuie-glace	Motor limpiaparabr.
32		31	➡ Ref. 31	1	Motor, Wiper	Moteur d'essuie-glace	Motor limpiaparabr.
33	3523335M91	31		1	Kit, Parts	Lot de pièces	Juego de piezas
34		33	➡ Ref. 33	1	Nut	Écrou	Tuerca
35		33	➡ Ref. 33	1	Washer	Rondelle	Arandela
36		33	➡ Ref. 33	1	Washer	Rondelle	Arandela
37		33	➡ Ref. 33	1	Cap	Chapeau	Sombbrero
38		33	➡ Ref. 33	1	Nut	Écrou	Tuerca
39	6099460M1	2		3	Tie, Cable	Attache câble	Enlace de Cable
40	6099758M1	2		1	Spacer	Entretoise	Traviesa



820 860 880 970 980
TX760B TX860B
TX870B TX970B

801 803 805 807 813 815 817 821 823 825 831 833 841 843 845 851 853 855 921
922 923 931 932

46016C03.1

6199042M3

1

Jan-06

Cab
Cabine
Cabina

Rear Worklight
Phare de Travail Arriere
Faro de trabajo trasera

C-46003-02.1-A

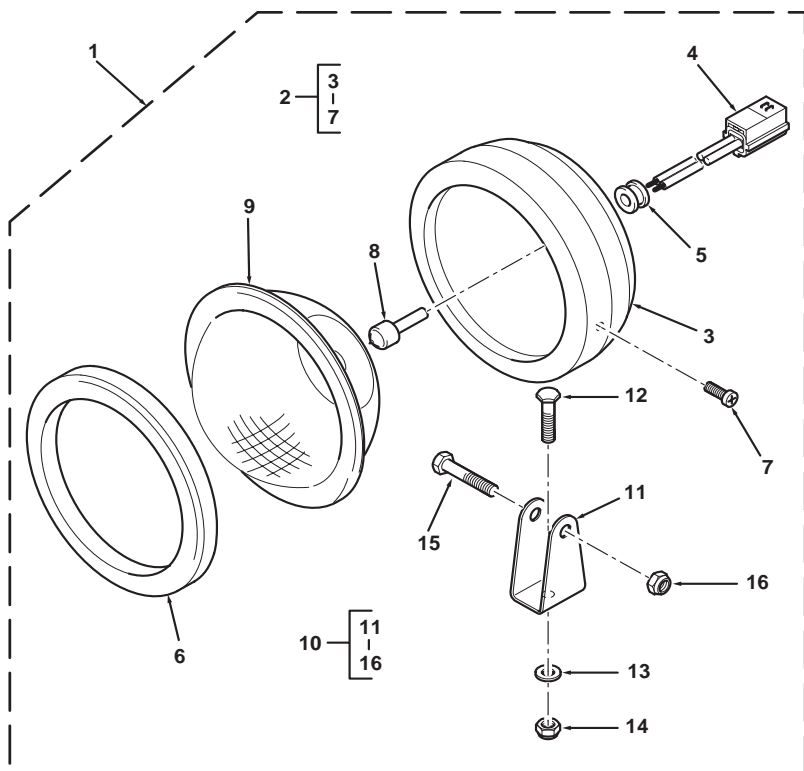

1	6110678M91		👁 46003C01.1 15	2	Lamp Assy, Work	Ensemble phare travail	Faro de trabajo, Conj.
2	6194299M91	1		1	Kit, Parts	Lot de pièces	Juego de piezas
3		2	🔩 Ref. 2	1	Body	Corps	Cuerpo
4		2	🔩 Ref. 2	1	Harness	Faisceau	Haz
5		2	🔩 Ref. 2	1	Grommet	Passe-fil	Pasa cable
6		2	🔩 Ref. 2	1	Rim	Jante	Corona
7		2	🔩 Ref. 2	1	Screw	Vis	Tornillo
8	3523689M1	1	12V - 55W	1	Bulb	Lampe	Lámpara
9	6194002M91	1		1	Reflector	Catadioptré	Reflector
10	6194003M91	1		1	Kit, Parts	Lot de pièces	Juego de piezas
11		10	🔩 Ref. 10	1	Bracket	Patte de fixation	Pata de fijación
12		10	🔩 Ref. 10	1	Bolt	Boulon	Perno
13		10	🔩 Ref. 10	1	Washer	Rondelle	Arandela
14		10	🔩 Ref. 10	1	Nut	Écrou	Tuerca
15		10	🔩 Ref. 10	1	Bolt	Boulon	Perno
16		10	🔩 Ref. 10	1	Nut	Écrou	Tuerca



820 860 880
TX760B TX860B
TX870B

802 804 806 808 810 812 814 816 822 824 832 834 842 844 852 854

46003C02.1

6199042M3

1

Jan-06

Cab
Cabine
Cabina

Rear Worklight
Phare de Travail Arriere
Faro de trabajo trasera

C-46005-02.1-A

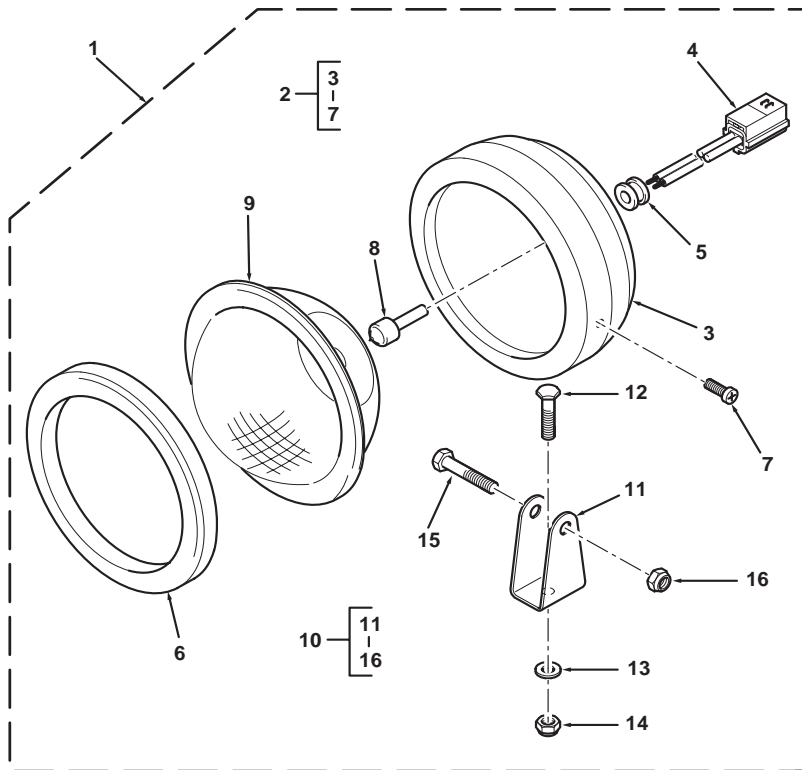

1	6110678M91		👁️ 46005C01.1 15	2	Lamp Assy, Work	Ensemble phare travail	Faro de trabajo, Conj.
2	6194299M91	1		1	Kit, Parts	Lot de pièces	Juego de piezas
3		2	🔩 Ref. 2	1	Body	Corps	Cuerpo
4		2	🔩 Ref. 2	1	Harness	Faisceau	Haz
5		2	🔩 Ref. 2	1	Grommet	Passe-fil	Pasa cable
6		2	🔩 Ref. 2	1	Rim	Jante	Corona
7		2	🔩 Ref. 2	1	Screw	Vis	Tornillo
8	3523689M1	1	12V - 55W	1	Bulb	Lampe	Lámpara
9	6194002M91	1		1	Reflector	Catadioptré	Reflector
10	6194003M91	1		1	Kit, Parts	Lot de pièces	Juego de piezas
11		10	🔩 Ref. 10	1	Bracket	Patte de fixation	Pata de fijación
12		10	🔩 Ref. 10	1	Bolt	Boulon	Perno
13		10	🔩 Ref. 10	1	Washer	Rondelle	Arandela
14		10	🔩 Ref. 10	1	Nut	Écrou	Tuerca
15		10	🔩 Ref. 10	1	Bolt	Boulon	Perno
16		10	🔩 Ref. 10	1	Nut	Écrou	Tuerca



820
TX760B

808

46005C02.1

6199042M3

1

Jan-06

Cab
Cabine
Cabina

Rear Worklight
Phare de Travail Arriere
Faro de trabajo trasera

C-46015-06.1-A

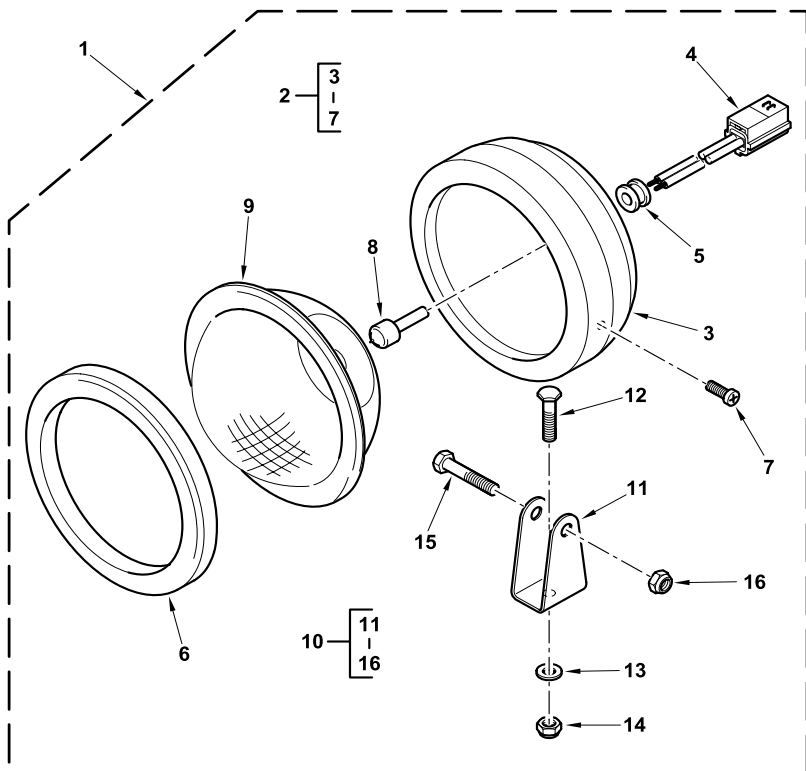

1	6110033M91		☉ [46015C04.1 15]	2	Lamp Assy, Work	Ensemble phare travail	Faro de trabajo, Conj.
2	6194001M91	1		1	Kit, Parts	Lot de pièces	Juego de piezas
3		2	☛ Ref. 2	1	Body	Corps	Cuerpo
4		2	☛ Ref. 2	1	Harness	Faisceau	Haz
5		2	☛ Ref. 2	1	Grommet	Passe-fil	Pasa cable
6		2	☛ Ref. 2	1	Rim	Jante	Corona
7		2	☛ Ref. 2	1	Screw	Vis	Tornillo
8	3523689M1	1	12V - 55W	1	Bulb	Lampe	Lámpara
9	6194002M91	1		1	Reflector	Catadioptré	Reflector
10	6194003M91	1		1	Kit, Parts	Lot de pièces	Juego de piezas
11		10	☛ Ref. 10	1	Bracket	Patte de fixation	Pata de fijación
12		10	☛ Ref. 10	1	Bolt	Boulon	Perno
13		10	☛ Ref. 10	1	Washer	Rondelle	Arandela
14		10	☛ Ref. 10	1	Nut	Écrou	Tuerca
15		10	☛ Ref. 10	1	Bolt	Boulon	Perno
16		10	☛ Ref. 10	1	Nut	Écrou	Tuerca



820 860 880 970 980
TX760B TX860B
TX870B TX970B

801 803 805 807 809 811 813 815 817 821 823 825 831 833 841 843 845 851 853
855 921 922 923 931 932

46015C06.1

6199042M3

1

Jan-06

Cab
Cabine
Cabina

Rear Worklight
Phare de Travail Arriere
Faro de trabajo trasera

C-46016-06.1-A

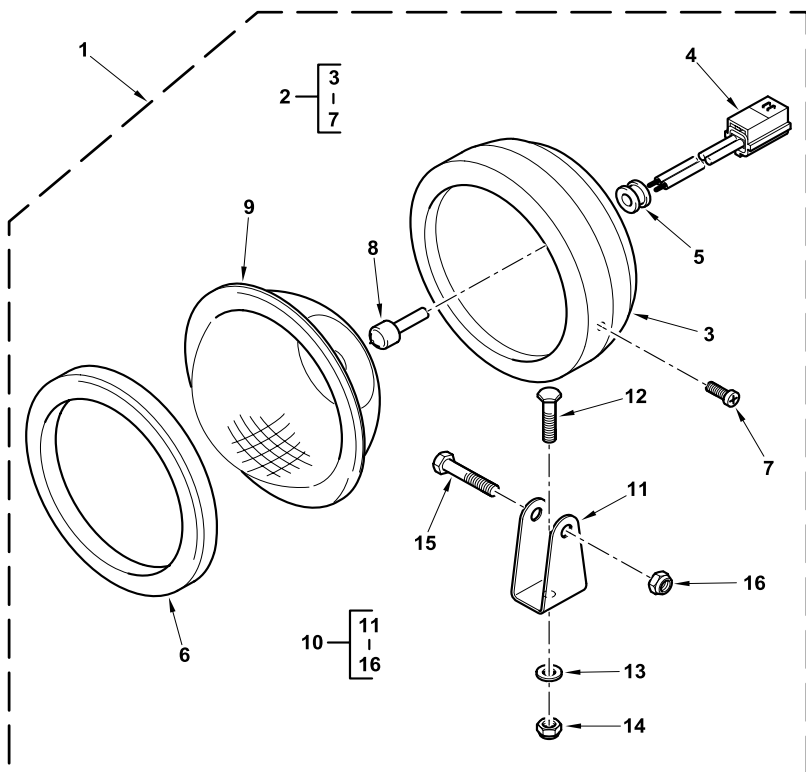

1	6110033M91		👁 [46016C04.1 15]	2	Lamp Assy, Work	Ensemble phare travail	Faro de trabajo, Conj.
2	6194001M91	1		1	Kit, Parts	Lot de pièces	Juego de piezas
3		2	🔩 Ref. 2	1	Body	Corps	Cuerpo
4		2	🔩 Ref. 2	1	Harness	Faisceau	Haz
5		2	🔩 Ref. 2	1	Grommet	Passe-fil	Pasa cable
6		2	🔩 Ref. 2	1	Rim	Jante	Corona
7		2	🔩 Ref. 2	1	Screw	Vis	Tornillo
8	3523689M1	1	12V - 55W	1	Bulb	Lampe	Lámpara
9	6194002M91	1		1	Reflector	Catadioptre	Reflector
10	6194003M91	1		1	Kit, Parts	Lot de pièces	Juego de piezas
11		10	🔩 Ref. 10	1	Bracket	Patte de fixation	Pata de fijación
12		10	🔩 Ref. 10	1	Bolt	Boulon	Perno
13		10	🔩 Ref. 10	1	Washer	Rondelle	Arandela
14		10	🔩 Ref. 10	1	Nut	Écrou	Tuerca
15		10	🔩 Ref. 10	1	Bolt	Boulon	Perno
16		10	🔩 Ref. 10	1	Nut	Écrou	Tuerca



820 860 880 970 980
TX760B TX860B
TX870B TX970B

801 803 805 807 813 815 817 821 823 825 831 833 841 843 845 851 853 855 921
922 923 931 932

46016C06.1

6199042M3

1

Jan-06

C-49011-01.1-A

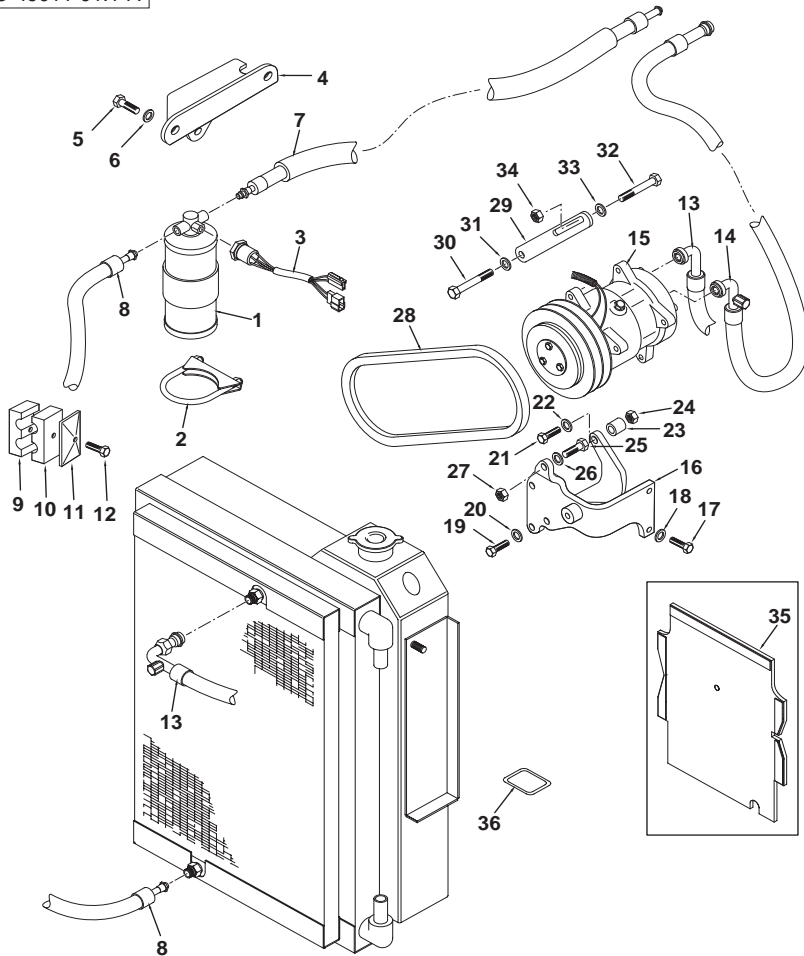

1	6106706M1		1	Receiver Dryer	Recev. Déshydrateur	Recept. Deshidratador
2	2700057M91		1	Clamp	Collier de serrage	Argolla de cierre
3	3517696M91		1	Switch	Contacteur	Contactar
4	6110163M1		1	Bracket	Patte de fixation	Pata de fijación
5	3009491X1	M10 x 20	2	Screw	Vis	Tornillo
6	390734X1	M10	2	Washer	Rondelle	Arandela
7	6109300M91		1	Hose Assy	Ensemble de flexible	Flexible, Conj.
8	6109301M91		1	Hose Assy	Ensemble de flexible	Flexible, Conj.
9	1470377M1		1	Bracket, Clamp	Bride de fixation	Brida de fijación
10	1470377M1		1	Bracket, Clamp	Bride de fixation	Brida de fijación
11	1470376M1		1	Plate	Plaque	Placa
12	339011X1	M8 x 45	1	Bolt	Boulon	Perno
13	6110165M91		1	Hose Assy	Ensemble de flexible	Flexible, Conj.
14	6110164M91		1	Hose Assy	Ensemble de flexible	Flexible, Conj.
15	1999755C2		1	Compressor	Compresseur	Compresor
16	6110143M93	Compressor	1	Bracket Assy	Ensemble chaise palier	Cuchara, Conj.
17	339009X1	M8 x 35	2	Screw	Vis	Tornillo
18	390972X1	M8	2	Washer	Rondelle	Arandela
19	3009494X1	M10 x 35	3	Screw	Vis	Tornillo
20	390734X1	M10	3	Washer	Rondelle	Arandela
21	3009496X1	M10 x 45	1	Screw	Vis	Tornillo
22	385362X1	M10	1	Washer	Rondelle	Arandela
23	6110144M1		1	Sleeve	Chemise	Camisa
24	6109236M1	M10	1	Nut	Écrou	Tuerca
25	3009495X1	M10 x 40	1	Screw	Vis	Tornillo
26	385362X1	M10	1	Washer	Rondelle	Arandela
27	6109236M1	M10	1	Nut	Écrou	Tuerca
28	6110133M1		1	Belt, V	Courroie trapézoïdale	Correa trapezoidal
29	6110132M1		1	Support	Support	Soporte
30	3009491X1	M10 x 20	1	Screw	Vis	Tornillo
31	390734X1	M10	1	Washer	Rondelle	Arandela
32	3009494X1	M10 x 35	1	Screw	Vis	Tornillo
33	385362X1	M10	1	Washer	Rondelle	Arandela
34	6109236M1	M10	1	Nut	Écrou	Tuerca
35	6110179M91		1	Insulation	Isolation	Aislante
36	3517592M1		3	Decal	Adhésif	Adhesivo



820 860 880 970 980
 TX760B TX860B
 TX870B TX970B

801 803 805 807 809 811 813 815 817 821 823 825 831 833 841 843 845 851 853
 855 921 922 923 931 932

Cab Environment
Poste de Conduite
Puesto de conducción

Air Conditioning Installation
Installation de Climatisation
Instalación climatizador

Rear
Arrière
Trasero

C-49011-03.1-A

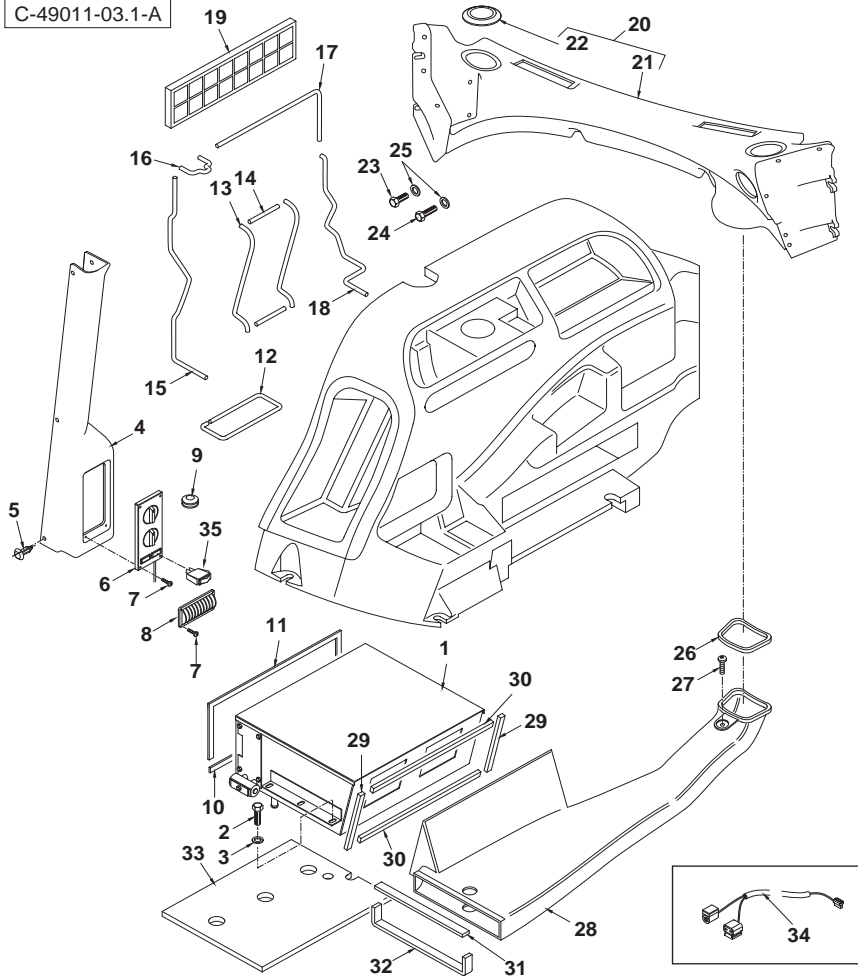

1		49011C04.1	1	Unit, Heater	Appareil de chauffage	Aparato calefacción
2	339560X1	M6 x 16	4	Screw	Vis	Tornillo
3	3019571X1		6	Washer	Rondelle	Arandela
4	6099527M1	"B POST"	1	Trim	Bande	Banda
5	6101591M1	Plastic	5	Rivet	Rivet	Remache
6	6106854M91		1	Switch Assy	Ensemble commutat.	Conmutador, Conj.
7	3522735M4	M3 x 16	8	Screw	Vis	Tornillo
8	6106727M1		1	Diffuser	Diffuseur	Difusor
9	6101552M1		1	Grommet	Passe-fil	Pasa cable
10	6101693M1	460 mm	1	Seal	Joint	Junta
11	6101692M1	810 mm	1	Seal	Joint	Junta
12	6101699M1	800 mm	1	Seal	Joint	Junta
13	6101694M1	270 mm	2	Seal	Joint	Junta
14	6101769M1	100 mm	2	Seal	Joint	Junta
15	6101695M1	1030 mm	1	Seal	Joint	Junta
16	6101698M1	140 mm	1	Seal	Joint	Junta
17	6101697M1	620 mm	1	Seal	Joint	Junta
18	6101696M1	975 mm	1	Seal	Joint	Junta
19	6101501M1		1	Filter	Filtre	Filtro
20	6102811M91	Rear	1	Trim	Bande	Banda
21		20 Ref. 20	1	Trim	Bande	Banda
22	6101499M1	20	6	Diffuser	Diffuseur	Difusor
23	339666X1	M6 x 20	4	Screw	Vis	Tornillo
24	339804X1	M6 x 25	2	Screw	Vis	Tornillo
25	3516109M1		6	Washer	Rondelle	Arandela
26	6101636M1		1	Seal	Joint	Junta
27	3009537X1	M5 x 20	1	Screw	Vis	Tornillo
28	6101718M91	"REAR"	1	Tube, Air	Chambre à air	Cámara de aire
29	6101633M1	167 mm	2	Seal	Joint	Junta
30	6101632M1	435 mm	2	Seal	Joint	Junta
31	6101666M1	295 mm	1	Seal	Joint	Junta
32	6101667M1	390 mm	1	Seal	Joint	Junta
33	6102447M2		1	Foam	Mousse	Espuma
34	6109814M91		1	Harness Assy	Ensemble de faisceau	Haz, Conj.
35	6110130M91	A/C	1	Switch Assy	Ensemble commutat.	Conmutador, Conj.



820 860 880 970 980
 TX760B TX860B
 TX870B TX970B

801 803 805 807 809 811 813 815 817 821 823 825 831 833 841 843 845 851 853
 855 921 922 923 931 932

49011C03.1

6199042M3

1

Jan-06

Cab Environment
Poste de Conduite
Puesto de conducción

Air Conditioning Unit
Climatiseur
Climatizador

C-49011-04.1-A

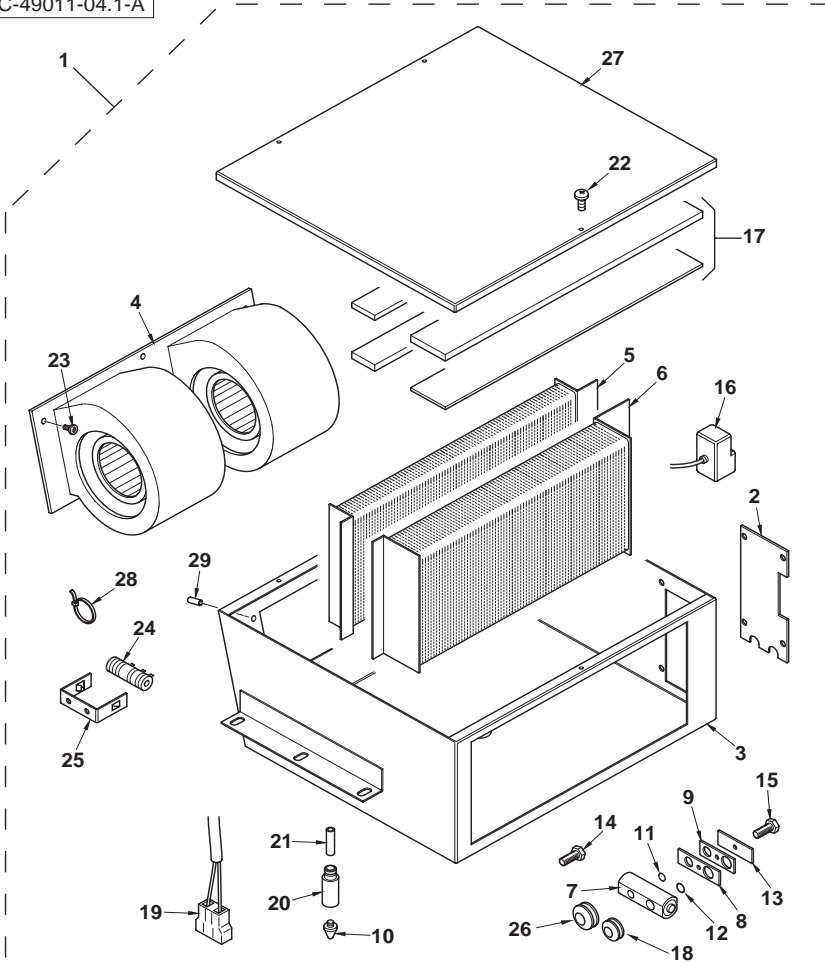

1	6108644M91	49011C02.1 1 49011C03.1 1	1	Air Conditioner	Climatisation	Climatizador
2		1 Ref. 1	1	Cover	Cache	Tapa
3		1 Ref. 1	1	Cover	Cache	Tapa
4	6193046M91	1	1	Blower	Soufflerie	Soplador
5	6193047M1	1 Heater	1	Coil	Bobine	Bobina
6	6193612M1	1 Evaporator	1	Coil	Bobine	Bobina
7	6193044M91	1	1	Valve	Soupape	Válvula
8	6193708M1	1	1	Plate	Plaque	Placa
9	6193045M1	1	1	Plate	Plaque	Placa
10	6193056M1	1	2	Valve, Drain	Robinet de vidange	Grifo de vaciado
11	6193041M1	1	1	O-Ring	Joint torique	Junta de tipo O
12	6193042M1	1	1	O-Ring	Joint torique	Junta de tipo O
13		1 Ref. 1	1	Clamp	Collier de serrage	Argolla de cierre
14		1 Ref. 1	2	Bolt	Boulon	Perno
15		1 Ref. 1	1	Bolt	Boulon	Perno
16	6193052M91	1	1	Thermostat	Thermostat	Termostato
17	6193051M91	1	1	Kit, Seal	Pochette de joints	Juego de juntas
18	6193039M1	1	3	Grommet	Passe-fil	Pasa cable
19	6193049M91	1	1	Harness Assy	Ensemble de faisceau	Haz, Conj.
20	6193040M91	1	2	Valve, Check	Clapet anti-retour	Válvula de parada
21	6193050M1	1	2	Pipe	Tuyau	Tubo
22		1 Ref. 1	15	Screw	Vis	Tornillo
23		1 Ref. 1	3	Screw	Vis	Tornillo
24	6193055M91	1	1	Resistor	Résistance	Resistencia
25	6193053M1	1	1	Bracket	Patte de fixation	Pata de fijación
26	6193054M1	1	1	Grommet	Passe-fil	Pasa cable
27		1 Ref. 1	1	Cover	Cache	Tapa
28		1 Ref. 1	1	Tie, Cable	Attache câble	Enlace de Cable
29		1 Ref. 1	3	Sleeve	Chemise	Camisa



820 860 880 970 980
 TX760B TX860B
 TX870B TX970B

801 803 805 807 809 811 813 815 817 821 823 825 831 833 841 843 845 851 853
 855 921 922 923 931 932

49011C04.1

6199042M3

1

Jan-06

Cab Environment
 Poste de Conduite
 Puesto de conducción

Heater Installation
 Circuit Chauffage
 Circuito de calefacción

Front
 Avant
 Delantero

C-49010-01.1-B

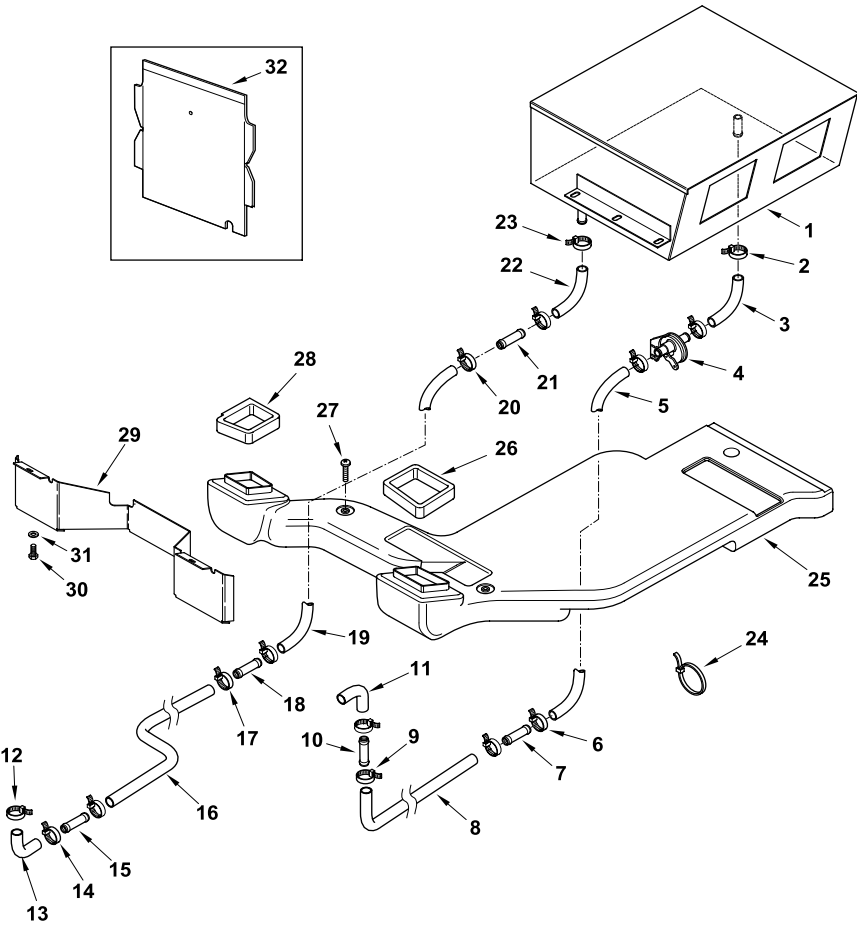

1		49010C03.1	1	Unit, Heater	Appareil de chauffage	Aparato calefacción
2	3517410M1		3	Clip	Clip	Clip
3	6107361M1		1	Elbow, 90°	Coude à 90°	Codo, 90°
4	6106705M1		1	Valve, Control	Distributeur	Distribuidor
5	6009515M1		1	Hose	Flexible	Tubo flexible
6	3517410M1		2	Clip	Clip	Clip
7	3521772M1		1	Connector	Connecteur	Conector
8	6003690M1		1	Hose	Flexible	Tubo flexible
9	3517410M1		2	Clip	Clip	Clip
10	3521772M1		1	Connector	Connecteur	Conector
11	3521752M1		1	Elbow, 90°	Coude à 90°	Codo, 90°
12	3517410M1		1	Clip	Clip	Clip
13	6107361M1		1	Elbow, 90°	Coude à 90°	Codo, 90°
14	3517410M1		2	Clip	Clip	Clip
15	3521772M1		1	Connector	Connecteur	Conector
16	6013369M1		1	Hose	Flexible	Tubo flexible
17	3517410M1		2	Clip	Clip	Clip
18	3521772M1		1	Connector	Connecteur	Conector
19	6110268M1		1	Hose	Flexible	Tubo flexible
20	3517410M1		2	Clip	Clip	Clip
21	3521772M1		1	Connector	Connecteur	Conector
22	6107361M1		1	Elbow, 90°	Coude à 90°	Codo, 90°
23	3517410M1		1	Clip	Clip	Clip
24	724497M1		5	Tie, Cable	Attache câble	Enlace de Cable
25	6101717M92		1	Tube, Air	Chambre à air	Cámara de aire
26	6101634M1		1	Seal	Joint	Junta
27	3009537X1	M5 x 20	2	Screw	Vis	Tornillo
28	6101635M1		1	Seal	Joint	Junta
29	6102371M3	Heat	1	Deflector	Défecteur	Deflector
30	339560X1	M6 x 16	2	Screw	Vis	Tornillo
31	3019571X1		2	Washer	Rondelle	Arandela
32	6110179M91		1	Insulation	Isolation	Aislante



820 860 880 970 980
 TX760B TX860B
 TX870B TX970B

801 803 805 807 809 811 813 815 817 821 823 825 831 833 841 843 845 851 853
 855 921 922 923 931 932

49010C01.1

6199042M3

1

Jan-06

Cab Environment
 Poste de Conduite
 Puesto de conducción

Heater Installation
 Circuit Chauffage
 Circuito de calefacción

Rear
 Arrière
 Trasero

C-49010-02.1-A

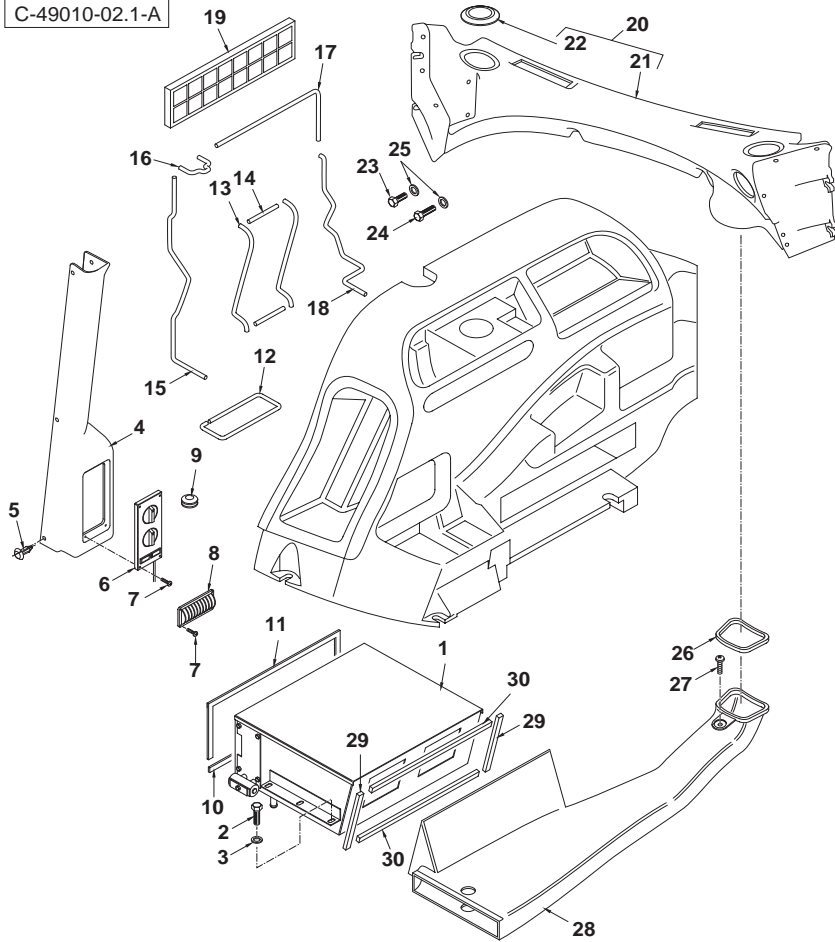

1		49010C03.1 1	1	Unit, Heater	Appareil de chauffage	Aparato calefacción
2	339560X1	M6 x 16	4	Screw	Vis	Tornillo
3	3019571X1		6	Washer	Rondelle	Arandela
4	6099527M1		1	Trim	Bande	Banda
5	6101591M1	Plastic	5	Rivet	Rivet	Remache
6	6106854M91		1	Switch Assy	Ensemble commutat.	Conmutador, Conj.
7	3522735M4	M3 x 16	8	Screw	Vis	Tornillo
8	6106727M1		1	Diffuser	Diffuseur	Difusor
9	6101552M1		1	Grommet	Passe-fil	Pasa cable
10	6101693M1	460 mm	1	Seal	Joint	Junta
11	6101692M1	810 mm	1	Seal	Joint	Junta
12	6101699M1	800 mm	1	Seal	Joint	Junta
13	6101694M1	270 mm	2	Seal	Joint	Junta
14	6101769M1	100 mm	2	Seal	Joint	Junta
15	6101695M1	1030 mm	1	Seal	Joint	Junta
16	6101698M1	140 mm	1	Seal	Joint	Junta
17	6101697M1	620 mm	1	Seal	Joint	Junta
18	6101696M1	975 mm	1	Seal	Joint	Junta
19	6101501M1		1	Filter	Filtre	Filtro
20	6102811M91	Rear	1	Trim	Bande	Banda
21		20 Ref. 20	1	Trim	Bande	Banda
22	6101499M1	20	6	Diffuser	Diffuseur	Difusor
23	339666X1	M6 x 20	4	Screw	Vis	Tornillo
24	339804X1	M6 x 25	2	Screw	Vis	Tornillo
25	3516109M1		6	Washer	Rondelle	Arandela
26	6101636M1		1	Seal	Joint	Junta
27	3009537X1	M5 x 20	1	Screw	Vis	Tornillo
28	6101718M91		1	Tube, Air	Chambre à air	Cámara de aire
29	6101633M1	167 mm	2	Seal	Joint	Junta
30	6101632M1	435 mm	2	Seal	Joint	Junta



820 860 880 970 980
 TX760B TX860B
 TX870B TX970B

801 803 805 807 809 811 813 815 817 821 823 825 831 833 841 843 845 851 853
 855 921 922 923 931 932

49010C02.1

6199042M3

1

Jan-06

Cab Environment
Poste de Conduite
Puesto de conducción

Heater Installation
Circuit Chauffage
Circuito de calefacción

Front
Avant
Delantero

C-49011-02.1-B

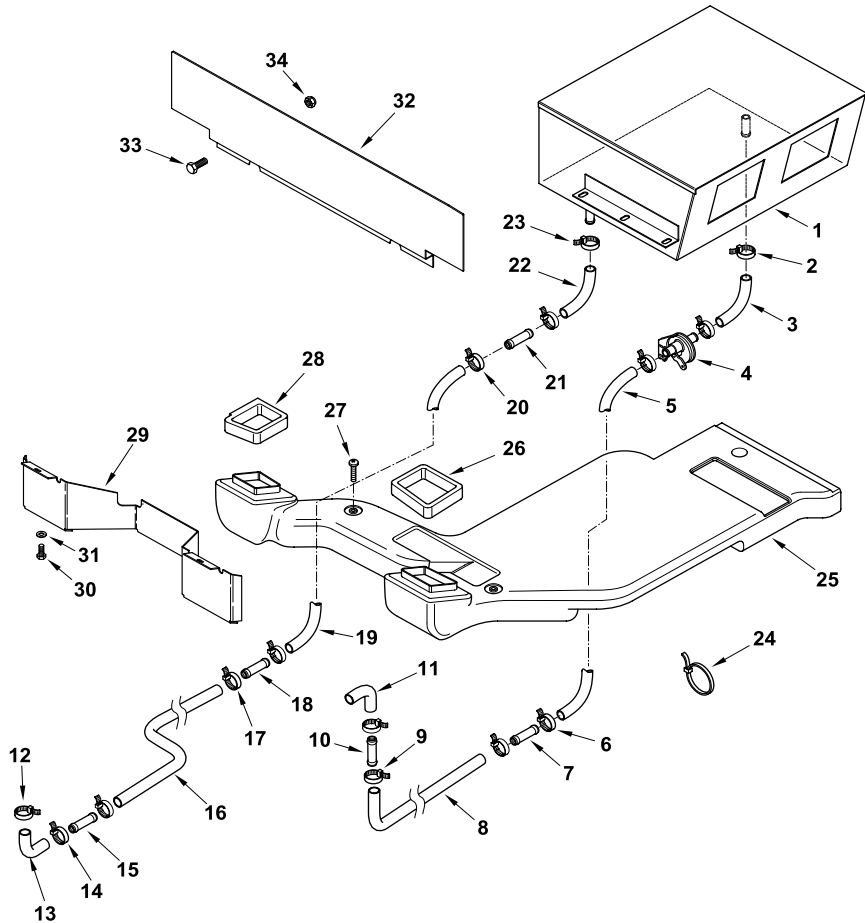

1		49011C04.1 1	1	Unit, Heater	Appareil de chauffage	Aparato calefacción
2	3517410M1		3	Clip	Clip	Clip
3	6107361M1		1	Elbow, 90°	Coude à 90°	Codo, 90°
4	6106705M1		1	Valve, Control	Distributeur	Distribuidor
5	6110268M1		1	Hose	Flexible	Tubo flexible
6	3517410M1		2	Clip	Clip	Clip
7	3521772M1		1	Connector	Connecteur	Conector
8	6003690M1		1	Hose	Flexible	Tubo flexible
9	3517410M1		2	Clip	Clip	Clip
10	3521772M1		1	Connector	Connecteur	Conector
11	3521752M1		1	Elbow, 90°	Coude à 90°	Codo, 90°
12	3517410M1		1	Clip	Clip	Clip
13	6107361M1		1	Elbow, 90°	Coude à 90°	Codo, 90°
14	3517410M1		2	Clip	Clip	Clip
15	3521772M1		1	Connector	Connecteur	Conector
16	6013369M1		1	Hose	Flexible	Tubo flexible
17	3517410M1		2	Clip	Clip	Clip
18	3521772M1		1	Connector	Connecteur	Conector
19	6110268M1		1	Hose	Flexible	Tubo flexible
20	3517410M1		2	Clip	Clip	Clip
21	3521772M1		1	Connector	Connecteur	Conector
22	6107361M1		1	Elbow, 90°	Coude à 90°	Codo, 90°
23	3517410M1		1	Clip	Clip	Clip
24	724497M1		5	Tie, Cable	Attache câble	Enlace de Cable
25	6101717M92		1	Tube, Air	Chambre à air	Cámara de aire
26	6101634M1		1	Seal	Joint	Junta
27	3009537X1	M5 x 20	2	Screw	Vis	Tornillo
28	6101635M1		1	Seal	Joint	Junta
29	6102371M3	Heat	1	Deflector	Défecteur	Deflector
30	339560X1	M6 x 16	2	Screw	Vis	Tornillo
31	3019571X1		2	Washer	Rondelle	Arandela
32	6102370M1	Air	1	Deflector	Défecteur	Deflector
33	339123X1	M8 x 20	2	Bolt	Boulon	Perno
34	394367X1	M8	2	Nut, Lock	Écrou de blocage	Tuerca de retención



820 860 880 970 980
TX760B TX860B
TX870B TX970B

801 803 805 807 809 811 813 815 817 821 823 825 831 833 841 843 845 851 853
855 921 922 923 931 932

49011C02.1

6199042M3

1

Jan-06

Cab Environment
Poste de Conduite
Puesto de conducción

Heater Unit
Dispositif de Chauffage
Dispositivo calefactor

C-49010-03.1-A

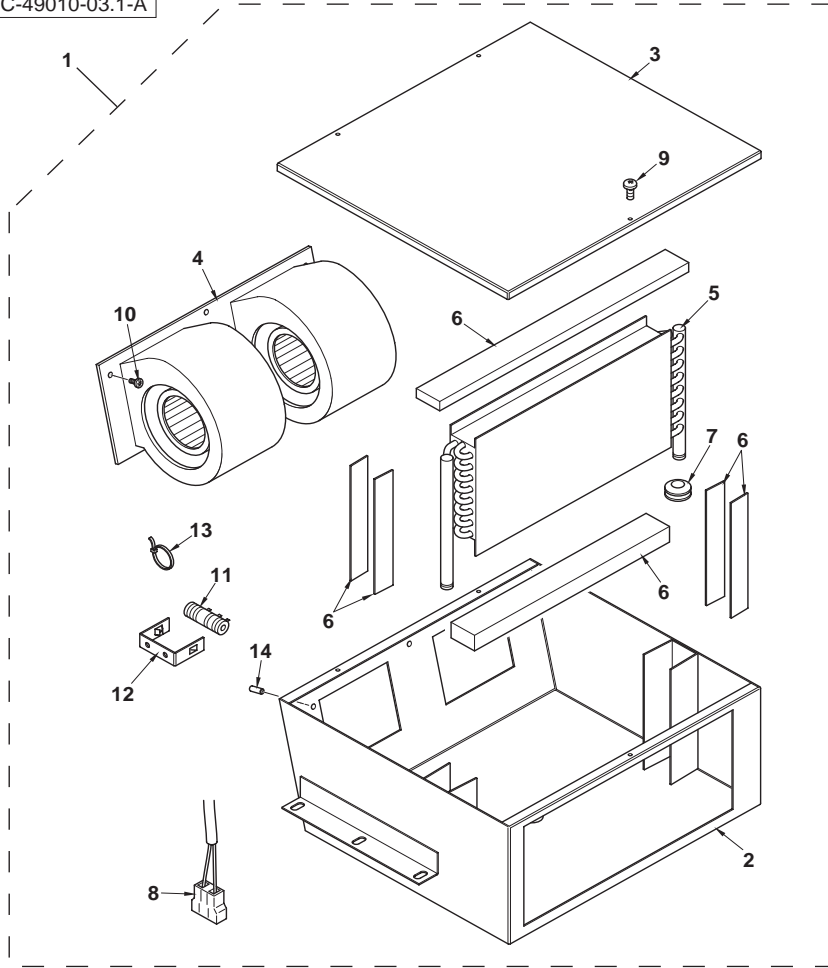

1	6106700M91	49010C01.1 1 49010C02.1 1	1	Heater	Chauffage	Calentador
2		1 Ref. 1	1	Body	Corps	Cuerpo
3		1 Ref. 1	1	Cover	Cache	Tapa
4	6193046M91	1	1	Blower	Soufflerie	Soplador
5	6193058M91	1	1	Coil	Bobine	Bobina
6	6193059M91	1	1	Kit, Seal	Pochette de joints	Juego de juntas
7	6193039M1	1	2	Grommet	Passe-fil	Pasa cable
8	6193057M91	1	1	Harness	Faisceau	Haz
9		1 Ref. 1	11	Screw	Vis	Tornillo
10		1 Ref. 1	3	Screw	Vis	Tornillo
11	6193055M91	1	1	Resistor	Résistance	Resistencia
12	6193053M1	1	1	Bracket	Patte de fixation	Pata de fijación
13		1 Ref. 1	1	Tie, Cable	Attache câble	Enlace de Cable
14		1 Ref. 1	3	Cap	Chapeau	Sombrerete



820 860 880 970 980
 TX760B TX860B
 TX870B TX970B

801 803 805 807 809 811 813 815 817 821 823 825 831 833 841 843 845 851 853
 855 921 922 923 931 932

49010C03.1

6199042M3

1

Jan-06

Cab Environment
Poste de Conduite
Puesto de conducción

Less Heater Unit
Sans Dispositif de Chauffage
Sin dispositivo calefactor

Rops
Rops
Rops

C-49012-01.1-A

1	6109660M1			2	Plug	Bouchon	Tapón
2	3517410M1			2	Clip	Clip	Clip
3	6109659M1			2	Tube	Tube	Tubo
4	3517410M1			2	Clip	Clip	Clip
5	6110179M91			1	Insulation	Isolation	Aislante

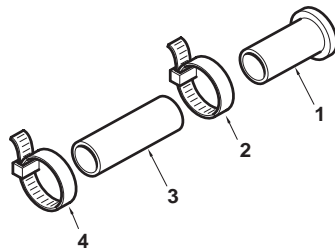
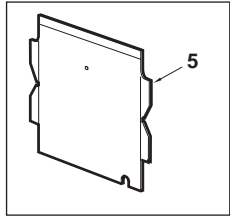

820 860 880
TX760B TX860B
TX870B

802 804 806 808 810 812 814 816 822 824 832 834 842 844 852 854

Cab Trim
Habillage de Cabine
Guarnición de cabina

Cab Mounting
Pièces de Montage
Piezas de montaje

C-47010-01.1-A

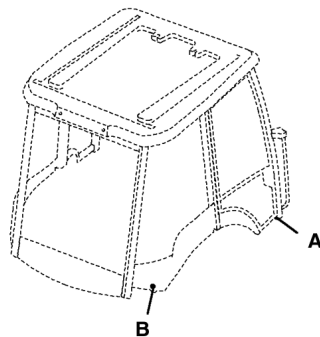

1	3521671M1		2	Cover	Cache	Tapa
2	391332X1	M20 x 100	2	Screw	Vis	Tornillo
3	385365X1	M20	4	Washer	Rondelle	Arandela
4	3521648M3	M20	2	Washer	Rondelle	Arandela
5	6101687M1	M20	2	Washer	Rondelle	Arandela
6	3507499M1		2	Insulator Block	Bloc isolant	Bloque aislante
7	3507500M1		2	Insulator Block	Bloc isolant	Bloque aislante
8	385365X1	M20	2	Washer	Rondelle	Arandela
9	339035X1	M20	2	Nut	Écrou	Tuerca
10	391332X1	M20 x 100	2	Screw	Vis	Tornillo
11	385365X1	M20	2	Washer	Rondelle	Arandela
12	3507500M1		2	Insulator Block	Bloc isolant	Bloque aislante
13	3507499M1		2	Insulator Block	Bloc isolant	Bloque aislante
14	6101687M1	M20	2	Washer	Rondelle	Arandela
15	3521648M3	M20	2	Washer	Rondelle	Arandela
16	385365X1	M20	2	Washer	Rondelle	Arandela
17	339035X1	M20	2	Nut	Écrou	Tuerca

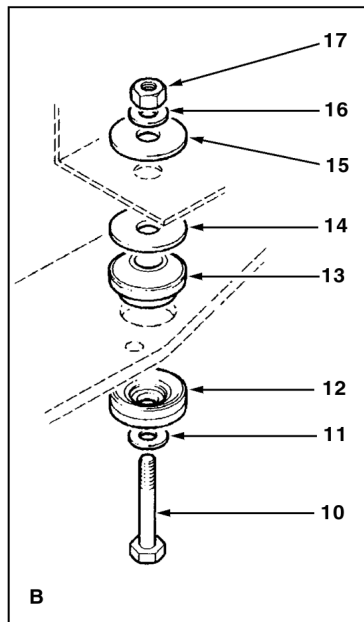
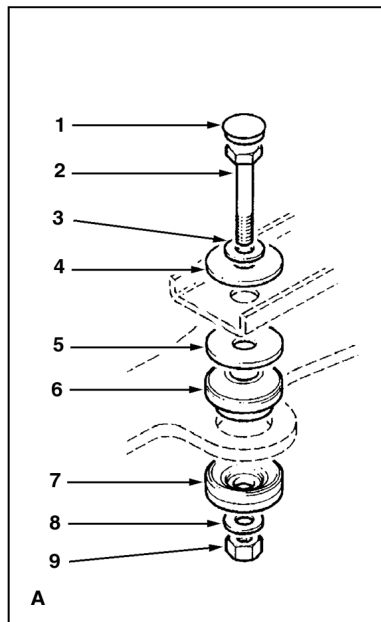

820 860 970
 TX760B TX860B
 TX870B

801 803 805 807 809 811 813 815 817 922 923

Cab Trim
Habillage de Cabine
Guarnición de cabina

Cab Mounting
Pièces de Montage
Piezas de montaje

C-47011-01.1-A

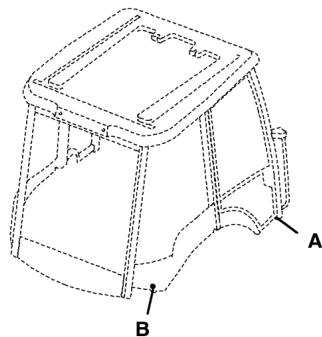

1	3521671M1		2	Cover	Cache	Tapa
2	391332X1	M20 x 100	2	Screw	Vis	Tornillo
3	385365X1	M20	4	Washer	Rondelle	Arandela
4	3521648M3	M20	2	Washer	Rondelle	Arandela
5	6101687M1	M20	2	Washer	Rondelle	Arandela
6	3507499M1		2	Insulator Block	Bloc isolant	Bloque aislante
7	3507500M1		2	Insulator Block	Bloc isolant	Bloque aislante
8	385365X1	M20	2	Washer	Rondelle	Arandela
9	339035X1	M20	2	Nut	Écrou	Tuerca
10	391332X1	M20 x 100	2	Screw	Vis	Tornillo
11	385365X1	M20	2	Washer	Rondelle	Arandela
12	3507500M1		2	Insulator Block	Bloc isolant	Bloque aislante
13	3507499M1		2	Insulator Block	Bloc isolant	Bloque aislante
14	6101687M1	M20	2	Washer	Rondelle	Arandela
15	3521648M3	M20	2	Washer	Rondelle	Arandela
16	385365X1	M20	2	Washer	Rondelle	Arandela
17	339035X1	M20	2	Nut	Écrou	Tuerca

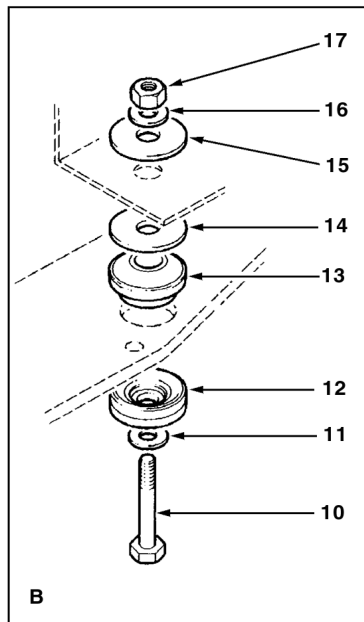
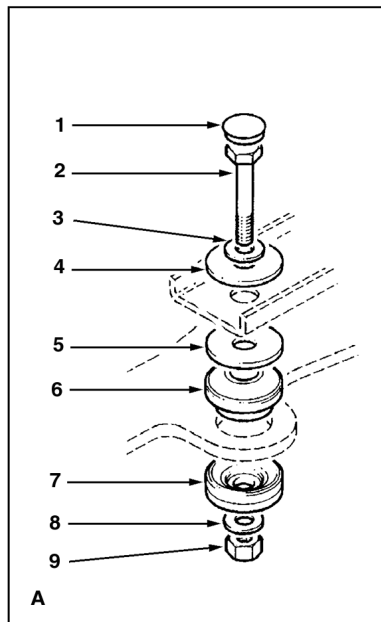

860 970
 TX860B TX870B

821 823 825 921 922 923

Cab Trim
Habillage de Cabine
Guarnición de cabina

Cab Mounting
Pièces de Montage
Piezas de montaje

4 Post ROPS
 4 Poteau ROPS
 4 poste ROPS

C-47012-01.1-A

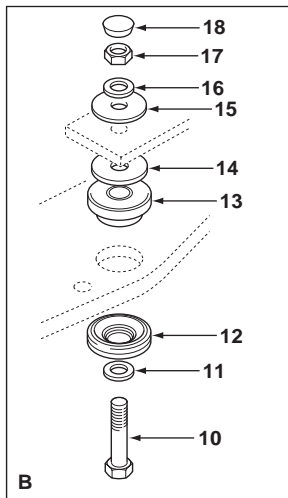
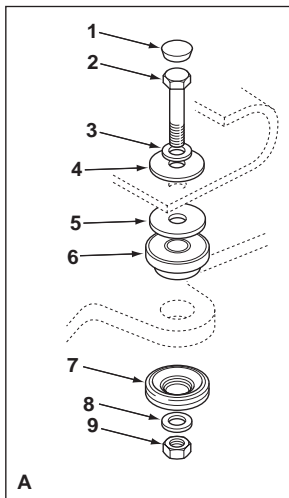
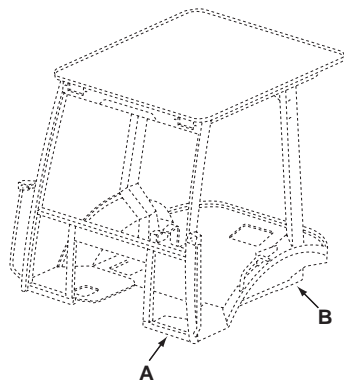

1	3521671M1		2	Cover	Cache	Tapa
2	391332X1	M20 x 100	2	Screw	Vis	Tornillo
3	385365X1	M20	4	Washer	Rondelle	Arandela
4	3521648M3	M20	2	Washer	Rondelle	Arandela
5	6101687M1	M20	2	Washer	Rondelle	Arandela
6	3507499M1		2	Insulator Block	Bloc isolant	Bloque aislante
7	3507500M1		2	Insulator Block	Bloc isolant	Bloque aislante
8	385365X1	M20	2	Washer	Rondelle	Arandela
9	339035X1	M20	2	Nut	Écrou	Tuerca
10	391332X1	M20 x 100	2	Screw	Vis	Tornillo
11	385365X1	M20	2	Washer	Rondelle	Arandela
12	3507500M1		2	Insulator Block	Bloc isolant	Bloque aislante
13	3507499M1		2	Insulator Block	Bloc isolant	Bloque aislante
14	6101687M1	M20	2	Washer	Rondelle	Arandela
15	3521648M3	M20	2	Washer	Rondelle	Arandela
16	385365X1	M20	2	Washer	Rondelle	Arandela
17	339035X1	M20	2	Nut	Écrou	Tuerca
18	3521671M1		2	Cover	Cache	Tapa



820 860
 TX760B TX860B
 TX870B

802 804 806 808 810 812 814 816

47012C01.1

6199042M3

1

Jan-06

Cab Trim
Habillage de Cabine
Guarnición de cabina

Cab Mounting
Pièces de Montage
Piezas de montaje

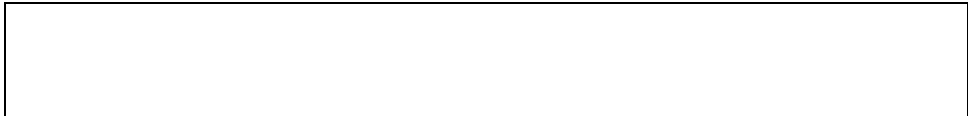

C-47014-01.1-A

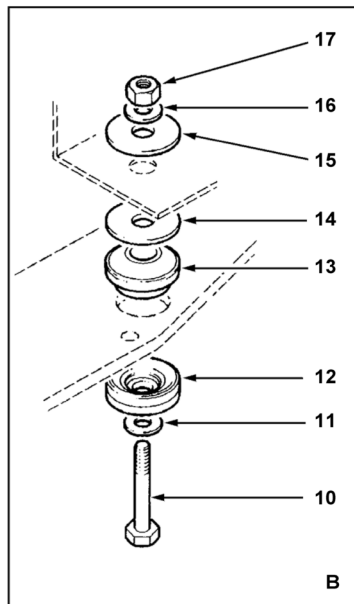
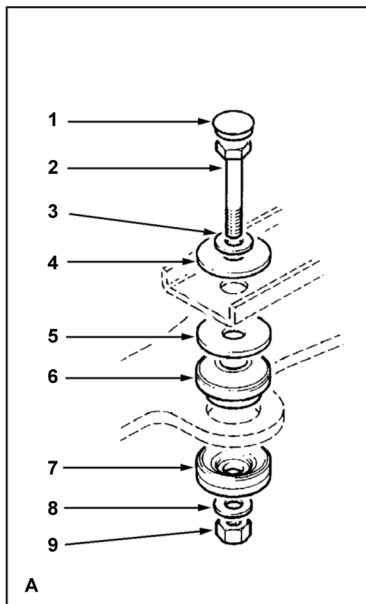
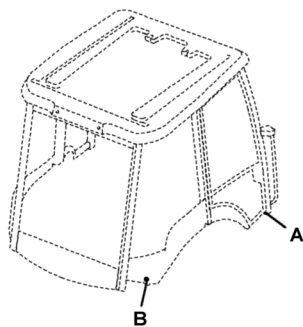

1	3521671M1		2	Cover	Cache	Tapa
2	391332X1	M20 x 100	2	Screw	Vis	Tornillo
3	385365X1	M20	4	Washer	Rondelle	Arandela
4	3521648M3	M20	2	Washer	Rondelle	Arandela
5	6101687M1	M20	2	Washer	Rondelle	Arandela
6	3507499M1		2	Insulator Block	Bloc isolant	Bloque aislante
7	3507500M1		2	Insulator Block	Bloc isolant	Bloque aislante
8	385365X1	M20	2	Washer	Rondelle	Arandela
9	339035X1	M20	2	Nut	Écrou	Tuerca
10	391332X1	M20 x 100	2	Screw	Vis	Tornillo
11	385365X1	M20	2	Washer	Rondelle	Arandela
12	3507500M1		2	Insulator Block	Bloc isolant	Bloque aislante
13	3507499M1		2	Insulator Block	Bloc isolant	Bloque aislante
14	6101687M1	M20	2	Washer	Rondelle	Arandela
15	3521648M3	M20	2	Washer	Rondelle	Arandela
16	385365X1	M20	2	Washer	Rondelle	Arandela
17	339035X1	M20	2	Nut	Écrou	Tuerca



880
 TX760B TX860B
 TX870B

831 833 841 843 845 851

Cab Trim
Habillage de Cabine
Guarnición de cabina

Cab Mounting
Pièces de Montage
Piezas de montaje

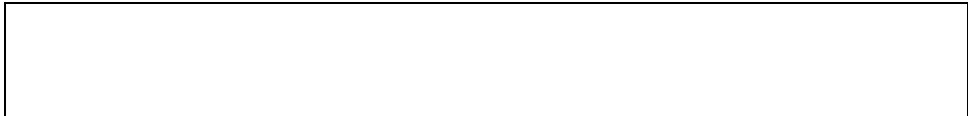

C-47015-01.1-A

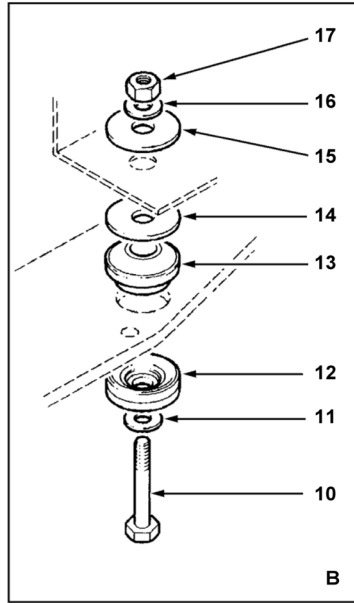
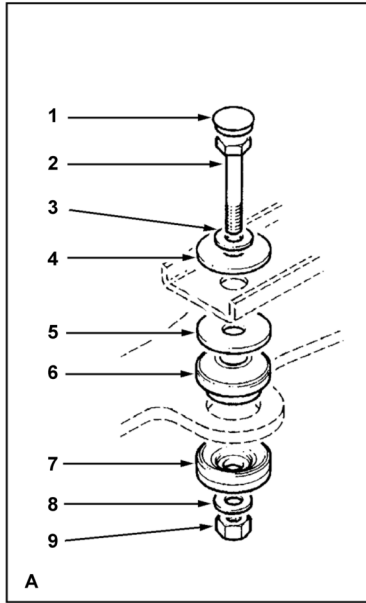
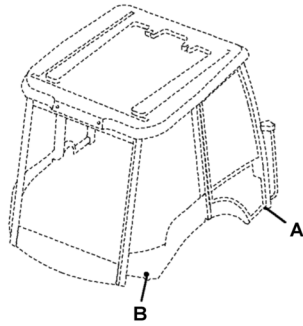

1	3521671M1		2	Cover	Cache	Tapa
2	391332X1	M20 x 100	2	Screw	Vis	Tornillo
3	385365X1	M20	4	Washer	Rondelle	Arandela
4	3521648M3	M20	2	Washer	Rondelle	Arandela
5	6101687M1	M20	2	Washer	Rondelle	Arandela
6	3507499M1		2	Insulator Block	Bloc isolant	Bloque aislante
7	3507500M1		2	Insulator Block	Bloc isolant	Bloque aislante
8	385365X1	M20	2	Washer	Rondelle	Arandela
9	339035X1	M20	2	Nut	Écrou	Tuerca
10	391332X1	M20 x 100	2	Screw	Vis	Tornillo
11	385365X1	M20	2	Washer	Rondelle	Arandela
12	3507500M1		2	Insulator Block	Bloc isolant	Bloque aislante
13	3507499M1		2	Insulator Block	Bloc isolant	Bloque aislante
14	6101687M1	M20	2	Washer	Rondelle	Arandela
15	3521648M3	M20	2	Washer	Rondelle	Arandela
16	385365X1	M20	2	Washer	Rondelle	Arandela
17	339035X1	M20	2	Nut	Écrou	Tuerca



880 980
 TX860B TX870B
 TX970B

841 843 845 851 853 855 931 932

Cab Trim
Habillage de Cabine
Guarnición de cabina

Cab Mounting
Pièces de Montage
Piezas de montaje

4 Post ROPS
 4 Poteau ROPS
 4 poste ROPS

C-47016-01.1-A

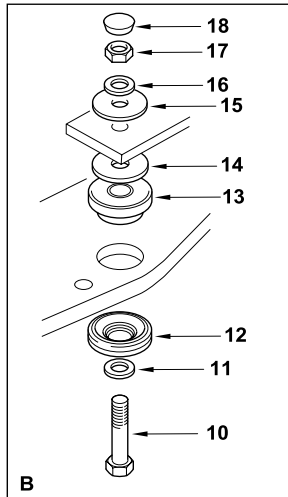
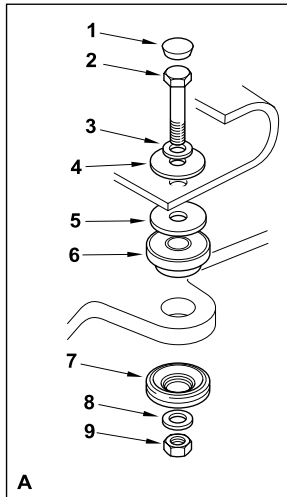
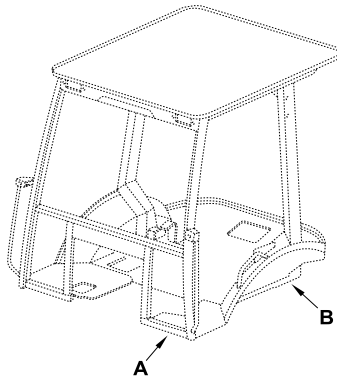

1	3521671M1		2	Cover	Cache	Tapa
2	391332X1	M20 x 100	2	Screw	Vis	Tornillo
3	385365X1	M20	4	Washer	Rondelle	Arandela
4	3521648M3	M20	2	Washer	Rondelle	Arandela
5	6101687M1	M20	2	Washer	Rondelle	Arandela
6	3507499M1		2	Insulator Block	Bloc isolant	Bloque aislante
7	3507500M1		2	Insulator Block	Bloc isolant	Bloque aislante
8	385365X1	M20	2	Washer	Rondelle	Arandela
9	339035X1	M20	2	Nut	Écrou	Tuerca
10	391332X1	M20 x 100	2	Screw	Vis	Tornillo
11	385365X1	M20	2	Washer	Rondelle	Arandela
12	3507500M1		2	Insulator Block	Bloc isolant	Bloque aislante
13	3507499M1		2	Insulator Block	Bloc isolant	Bloque aislante
14	6101687M1	M20	2	Washer	Rondelle	Arandela
15	3521648M3	M20	2	Washer	Rondelle	Arandela
16	385365X1	M20	2	Washer	Rondelle	Arandela
17	339035X1	M20	2	Nut	Écrou	Tuerca
18	3521671M1		2	Cover	Cache	Tapa



880
 TX760B TX860B
 TX870B

832 834 842 844

Cab Trim
Habillage de Cabine
Guarnición de cabina

Console
Console
Consola

C-47010-03.1-A

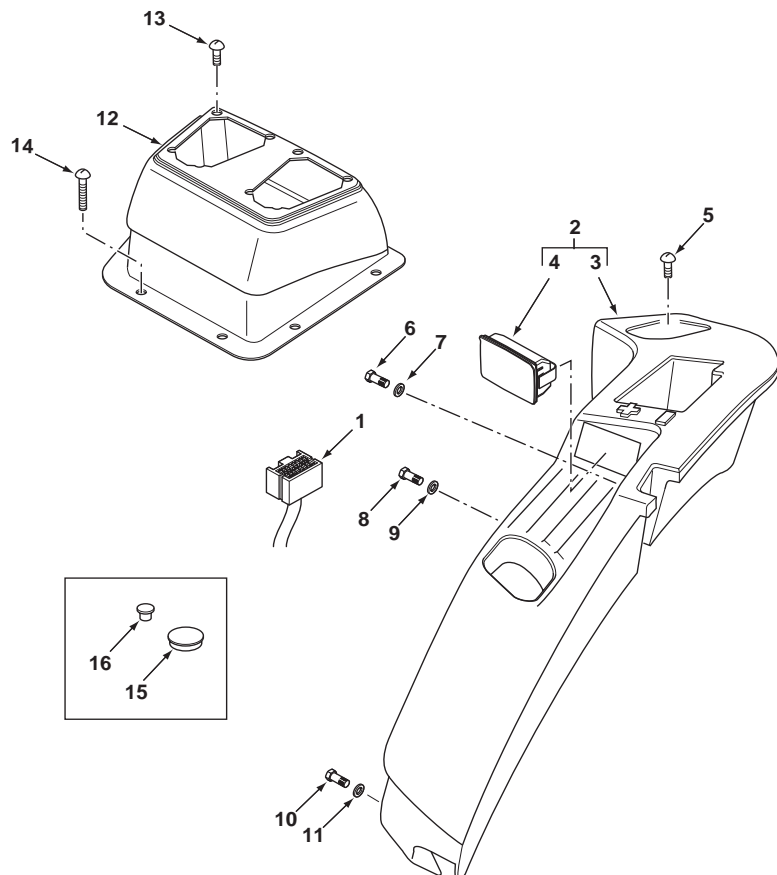

1	6110155M91		1	Harness Assy	Ensemble de faisceau	Haz, Conj.
2	6101811M91	LH Side	1	Console	Console	Consola
3		2 Ref. 2	1	Console	Console	Consola
4	6101503M91	2	1	Ashtray	Cendrier	Cenicero
5	6101591M1	Plastic	3	Rivet	Rivet	Remache
6	1440922X1	M6 x 60	1	Screw	Vis	Tornillo
7	3516109M1		1	Washer	Rondelle	Arandela
8	339262X1	M6 x 30	2	Bolt	Boulon	Perno
9	3516109M1		2	Washer	Rondelle	Arandela
10	339804X1	M6 x 25	1	Screw	Vis	Tornillo
11	3516109M1		1	Washer	Rondelle	Arandela
12	6099523M2		1	Console	Console	Consola
13	3521303M3		8	Fastener	Attache	Enganche
14	3512552M1	M5 x 12	6	Screw	Vis	Tornillo
15	6108072M1		2	Grommet	Passe-fil	Pasa cable
16	6108074M1		4	Fastener	Attache	Enganche



820 860 970
 TX760B TX860B
 TX870B

801 803 805 807 809 811 813 815 817 922 923

47010C03.1

6199042M3

1

Jan-06

Cab Trim
Habillage de Cabine
Guarnición de cabina

Console
Console
Consola

C-47011-03.1-A

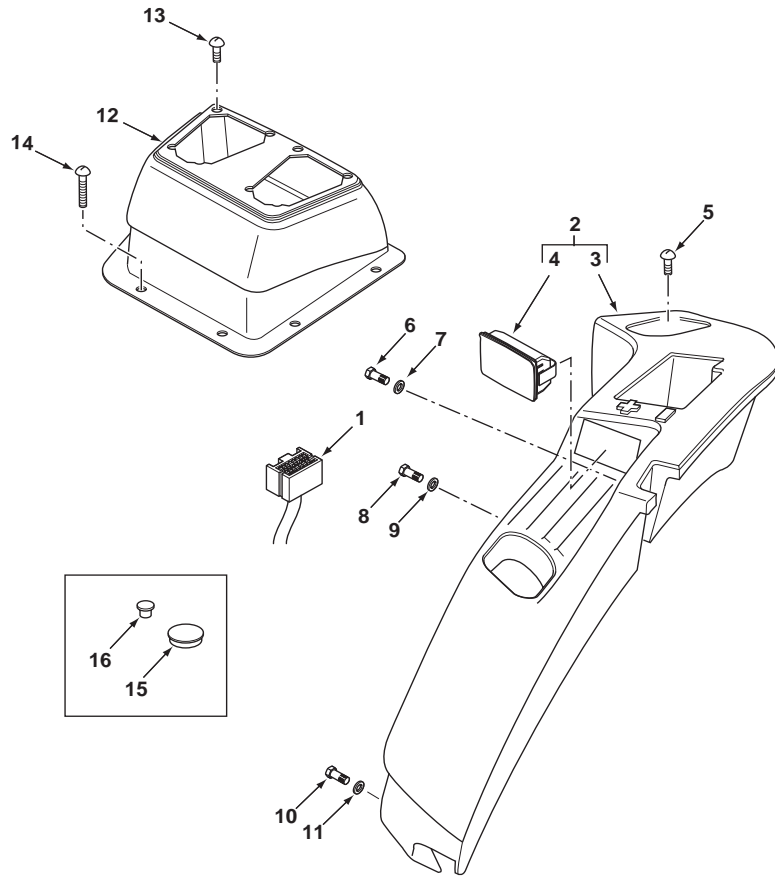

1	6110154M91		1	Harness Assy	Ensemble de faisceau	Haz, Conj.
2	6101811M91	LH Side	1	Console	Console	Consola
3		2 Ref. 2	1	Console	Console	Consola
4	6101503M91	2	1	Ashtray	Cendrier	Cenicero
5	6101591M1	Plastic	3	Rivet	Rivet	Remache
6	1440922X1	M6 x 60	1	Screw	Vis	Tornillo
7	3516109M1		1	Washer	Rondelle	Arandela
8	339262X1	M6 x 30	2	Bolt	Boulon	Perno
9	3516109M1		2	Washer	Rondelle	Arandela
10	339804X1	M6 x 25	1	Screw	Vis	Tornillo
11	3516109M1		1	Washer	Rondelle	Arandela
12	6099523M2		1	Console	Console	Consola
13	3521303M3		8	Fastener	Attache	Eganche
14	3512552M1	M5 x 12	6	Screw	Vis	Tornillo
15	6108072M1		2	Grommet	Passe-fil	Pasa cable
16	6108074M1		4	Fastener	Attache	Eganche



860 970
 TX860B TX870B

821 823 825 921 922 923

47011C03.1

6199042M3

1

Jan-06

Cab Trim
Habillage de Cabine
Guarnición de cabina

Console
Console
Consola

C-47014-03.1-A

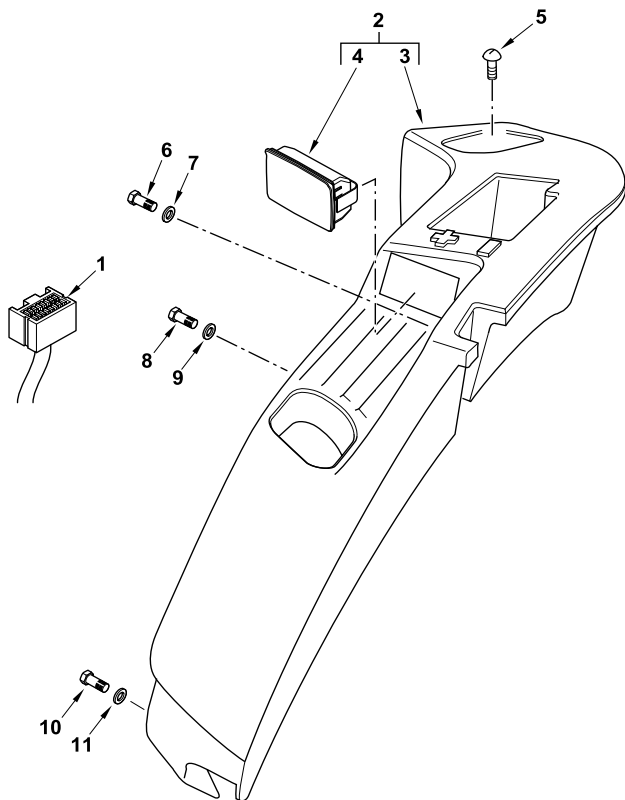

1	6110155M91		1	Harness Assy	Ensemble de faisceau	Haz, Conj.
2	6101811M91	LH Side	1	Console	Console	Consola
3		2 Ref. 2	1	Console	Console	Consola
4	6101503M91	2	1	Ashtray	Cendrier	Cenicero
5	6101591M1	Plastic	3	Rivet	Rivet	Remache
6	1440922X1	M6 x 60	1	Screw	Vis	Tornillo
7	3516109M1		1	Washer	Rondelle	Arandela
8	339262X1	M6 x 30	2	Bolt	Boulon	Perno
9	3516109M1		2	Washer	Rondelle	Arandela
10	339804X1	M6 x 25	1	Screw	Vis	Tornillo
11	3516109M1		1	Washer	Rondelle	Arandela
12	6108072M1		2	Grommet	Passe-fil	Pasa cable
13	6108074M1		4	Fastener	Attache	Enganche



880
 TX760B TX860B
 TX870B

831 833 841 843 845 851

47014C03.1

6199042M3

1

Jan-06

Cab Trim
Habillage de Cabine
Guarnición de cabina

Console
Console
Consola

C-47015-03.1-A

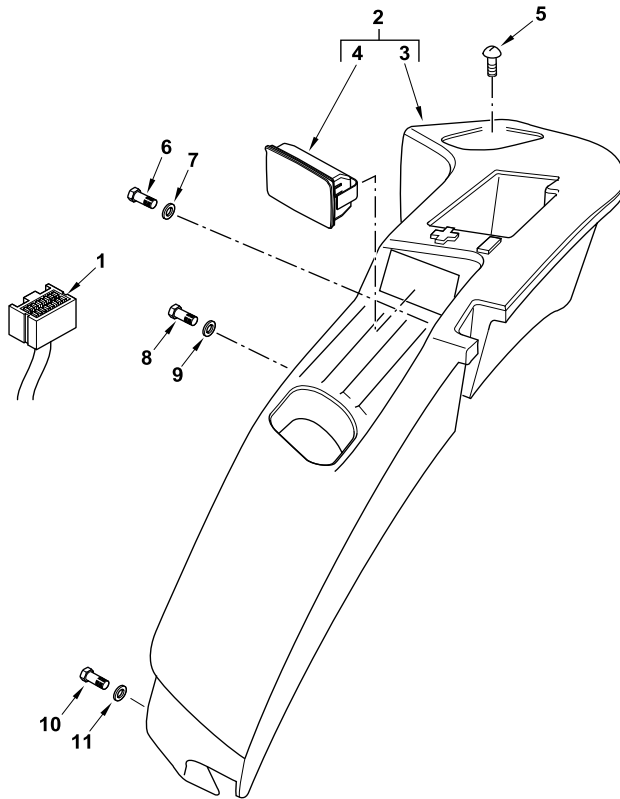

1	6110863M91		1	Harness Assy	Ensemble de faisceau	Haz, Conj.
2	6101811M91	LH Side	1	Console	Console	Consola
3		2 Ref. 2	1	Console	Console	Consola
4	6101503M91	2	1	Ashtray	Cendrier	Cenicero
5	6101591M1	Plastic	3	Rivet	Rivet	Remache
6	1440922X1	M6 x 60	1	Screw	Vis	Tornillo
7	3516109M1		1	Washer	Rondelle	Arandela
8	339262X1	M6 x 30	2	Bolt	Boulon	Perno
9	3516109M1		2	Washer	Rondelle	Arandela
10	339804X1	M6 x 25	1	Screw	Vis	Tornillo
11	3516109M1		1	Washer	Rondelle	Arandela
12	6108072M1		2	Grommet	Passe-fil	Pasa cable
13	6108074M1		4	Fastener	Attache	Enganche



880 980
 TX860B TX870B
 TX970B

841 843 845 851 853 855 931 932

47015C03.1

6199042M3

1

Jan-06

Cab Trim
Habillage de Cabine
Guarnición de cabina

Floorplate
Plaque du Sol
Placa de piso

Cab
 Cabine
 Cabina

C-47010-02.1-A

1		👁 [Cab Frame]	1	Plate	Plaque	Placa
2	339124X1	M8 x 16	5	Screw	Vis	Tornillo
3	6101043M2		1	Plate	Plaque	Placa
4	339124X1	M8 x 16	7	Screw	Vis	Tornillo
5	6101023M92		1	Plate Assy	Ensemble de plaque	Placa, Conj.
6	339124X1	M8 x 16	5	Screw	Vis	Tornillo
7	6110314M1		1	Mat, Floor	Tapis de plancher	Tapete de suelo
8	6110315M1		1	Mat, Floor	Tapis de plancher	Tapete de suelo
9	6110318M1		1	Mat	Tapis	Tapete
10	6110319M1		1	Mat	Tapis	Tapete

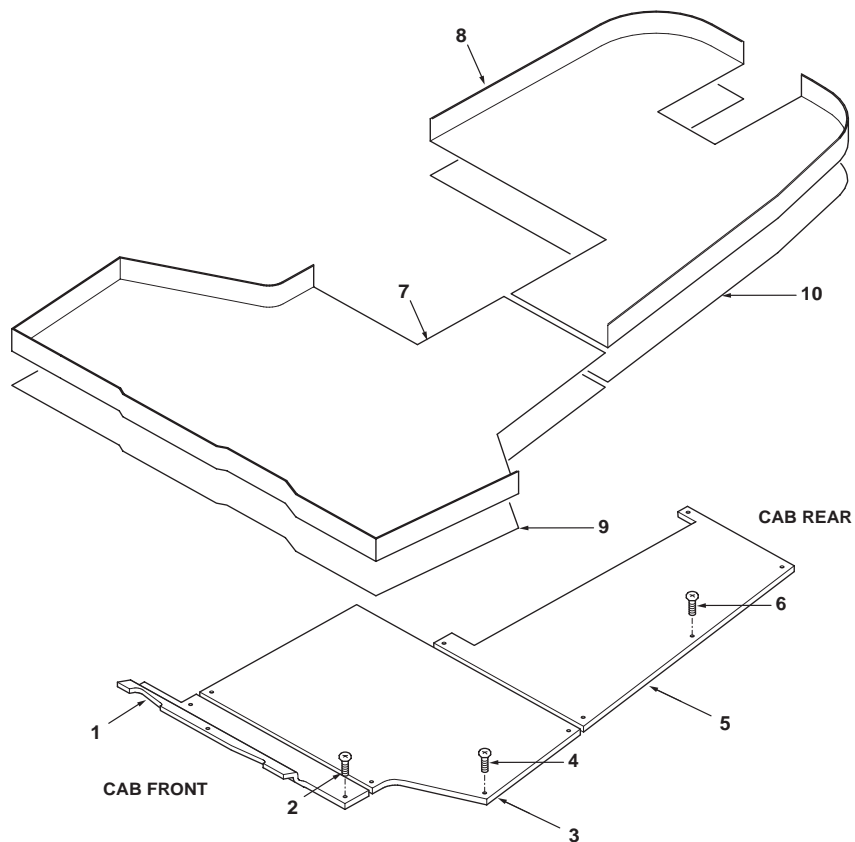

820 860 970
 TX760B TX860B
 TX870B

801 803 805 807 809 811 813 815 817 922 923

47010C02.1

6199042M3

1

Jan-06

Cab Trim
Habillage de Cabine
Guarnición de cabina

Floorplate
Plaque du Sol
Placa de piso

Cab
 Cabine
 Cabina

C-47011-02.1-A

1		👁 [Cab Frame]	1	Plate	Plaque	Placa
2	339124X1	M8 x 16	5	Screw	Vis	Tornillo
3	6101043M2		1	Plate	Plaque	Placa
4	339124X1	M8 x 16	7	Screw	Vis	Tornillo
5	6101023M92		1	Plate Assy	Ensemble de plaque	Placa, Conj.
6	339124X1	M8 x 16	5	Screw	Vis	Tornillo
7	6110313M1		1	Mat, Floor	Tapis de plancher	Tapete de suelo
8	6110315M1		1	Mat, Floor	Tapis de plancher	Tapete de suelo
9	6110318M1		1	Mat	Tapis	Tapete
10	6110319M1		1	Mat	Tapis	Tapete

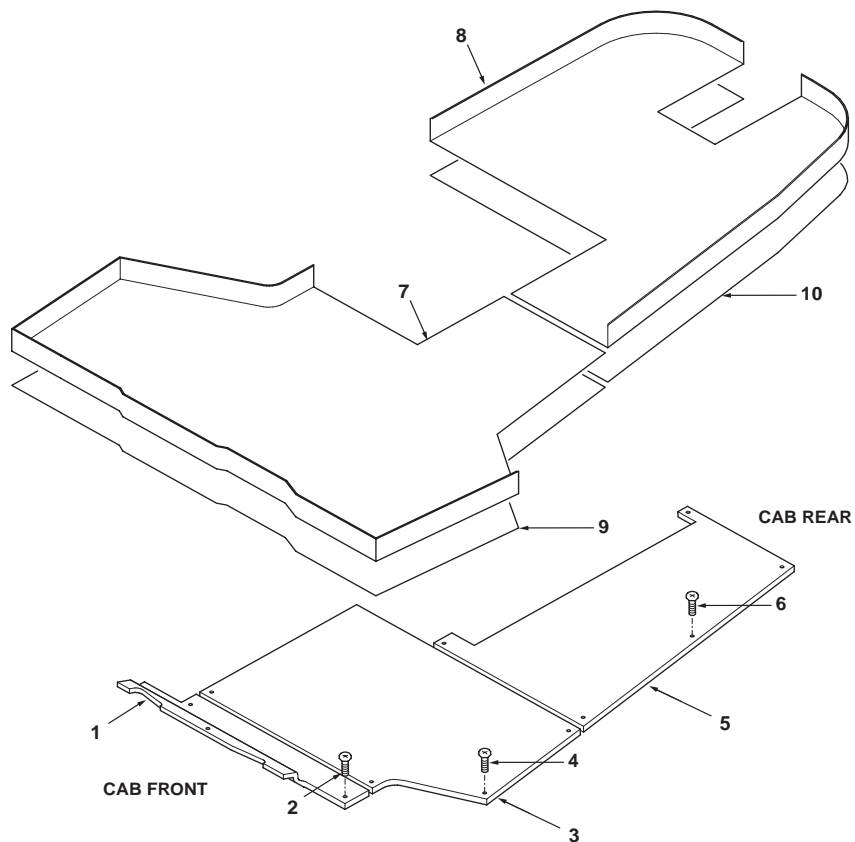

860 970
 TX860B TX870B

821 823 825 921 922 923

47011C02.1

6199042M3

1

Jan-06

Cab Trim
Habillage de Cabine
Guarnición de cabina

Floorplate
Plaque du Sol
Placa de piso

4 Post ROPS
 4 Poteau ROPS
 4 poste ROPS

C-47012-02.1-A

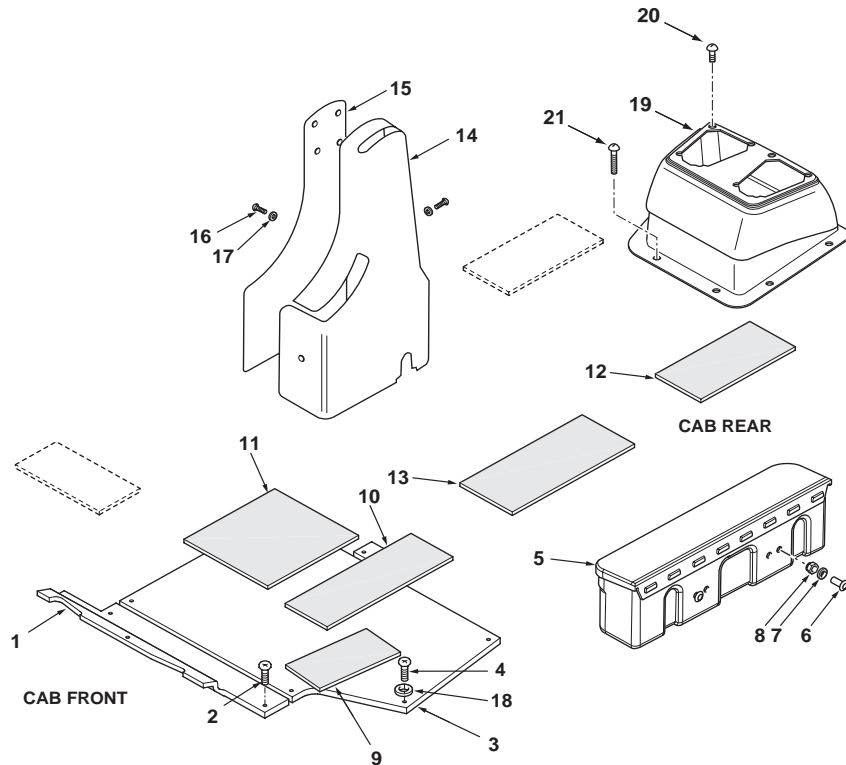

1		☉ [Cab Frame]	1	Plate	Plaque	Placa
2	339124X1	M8 x 16	5	Screw	Vis	Tornillo
3	6108654M1		1	Plate, Floor	Plancher	Suelo
4	339124X1	M8 x 16	7	Screw	Vis	Tornillo
5	1696186M93		1	Box, Storage	Coffre	Portaobjetos
6	3505771M1	M10 x 25	2	Screw	Vis	Tornillo
7	390734X1	M10	2	Washer	Rondelle	Arandela
8	1440329X1	M10	2	Nut, Lock	Écrou de blocage	Tuerca de retención
9	3517596M1	152.4 x 310 mm	2	Pad, Anti Slip	Plaque, anti-dérapant	Cinta antideslizante
10	3517595M1	152.4 x 400 mm	1	Pad, Anti Slip	Plaque, anti-dérapant	Cinta antideslizante
11	3517597M1	304.8 x 310 mm	1	Pad, Anti Slip	Plaque, anti-dérapant	Cinta antideslizante
12	3517596M1	152.4 x 310 mm	2	Pad, Anti Slip	Plaque, anti-dérapant	Cinta antideslizante
13	3517595M1	152.4 x 400 mm	1	Pad, Anti Slip	Plaque, anti-dérapant	Cinta antideslizante
14	6109251M1		1	Cover	Cache	Tapa
15	6109252M1		1	Sheet	Tôle	Chapa
16	3001163X1	M5 x 16	3	Screw	Vis	Tornillo
17	3019560X1		3	Washer	Rondelle	Arandela
18	390972X1	M8	7	Washer	Rondelle	Arandela
19	6108459M3		1	Console	Console	Consola
20	3521303M3		8	Fastener	Attache	Enganche
21	3512552M1	M5 x 12	6	Screw	Vis	Tornillo



820 860
 TX760B TX860B
 TX870B

802 804 806 808 810 812 814 816

47012C02.1

6199042M3

1

Jan-06

Cab Trim
Habillage de Cabine
Guarnición de cabina

Floorplate
Plaque du Sol
Placa de piso

C-47014-02.1-A

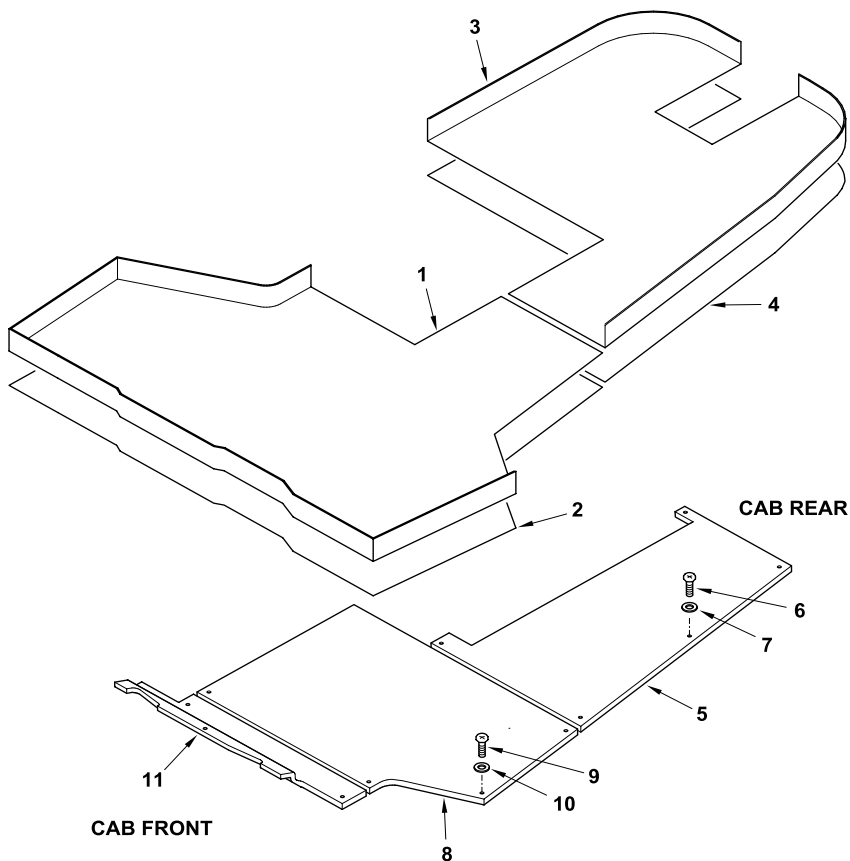

1	6110314M1			1	Mat, Floor	Tapis de plancher	Tapete de suelo
2	6110318M1			1	Mat	Tapis	Tapete
3	6110315M1			1	Mat, Floor	Tapis de plancher	Tapete de suelo
4	6110319M1			1	Mat	Tapis	Tapete
5	6101023M92			1	Plate Assy	Ensemble de plaque	Placa, Conj.
6	339124X1	M8 x 16		5	Screw	Vis	Tornillo
7	390972X1	M8		5	Washer	Rondelle	Arandela
8	6101043M2			1	Plate	Plaque	Placa
9	339124X1	M8 x 16		7	Screw	Vis	Tornillo
10	390972X1	M8		7	Washer	Rondelle	Arandela
11			● Cab Frame	1	Plate	Plaque	Placa



880
 TX760B TX860B
 TX870B

831 833 841 843 845 851

47014C02.1

6199042M3

1

Jan-06

Cab Trim
Habillage de Cabine
Guarnición de cabina

Floorplate
Plaque du Sol
Placa de piso

C-47015-02.1-A

1	6110314M1			1	Mat, Floor	Tapis de plancher	Tapete de suelo
2	6110318M1			1	Mat	Tapis	Tapete
3	6110315M1			1	Mat, Floor	Tapis de plancher	Tapete de suelo
4	6110319M1			1	Mat	Tapis	Tapete
5	6101023M92			1	Plate Assy	Ensemble de plaque	Placa, Conj.
6	339124X1	M8 x 16		5	Screw	Vis	Tornillo
7	390972X1	M8		5	Washer	Rondelle	Arandela
8	6101043M2			1	Plate	Plaque	Placa
9	339124X1	M8 x 16		7	Screw	Vis	Tornillo
10	390972X1	M8		7	Washer	Rondelle	Arandela
11			● Cab Frame	1	Plate	Plaque	Placa

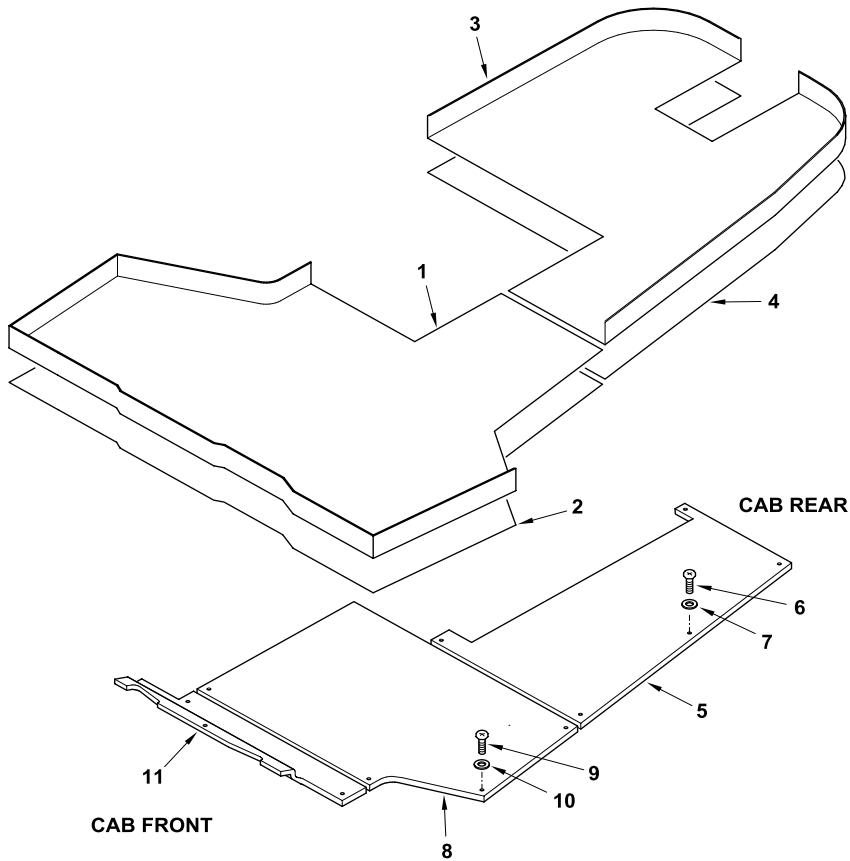

880 980
 TX860B TX870B
 TX970B

841 843 845 851 853 855 931 932

47015C02.1

6199042M3

1

Jan-06

Cab Trim
Habillage de Cabine
Guarnición de cabina

Floorplate
Plaque du Sol
Placa de piso

4 Post ROPS
 4 Poteau ROPS
 4 poste ROPS

C-47016-02.1-A

1	6108654M1		1	Plate, Floor	Plancher	Suelo
2	339124X1	M8 x 16	7	Screw	Vis	Tornillo
3	390972X1	M8	7	Washer	Rondelle	Arandela
4		☉ Cab Frame	1	Plate	Plaque	Placa
5	3517596M1	152.4 x 310 mm	2	Pad, Anti Slip	Plaque, anti-dérapant	Cinta antideslizante
6	3517595M1	152.4 x 400 mm	1	Pad, Anti Slip	Plaque, anti-dérapant	Cinta antideslizante
7	3517597M1	304.8 x 310 mm	1	Pad, Anti Slip	Plaque, anti-dérapant	Cinta antideslizante
8	3517595M1	152.4 x 400 mm	1	Pad, Anti Slip	Plaque, anti-dérapant	Cinta antideslizante
9	3517596M1	152.4 x 310 mm	2	Pad, Anti Slip	Plaque, anti-dérapant	Cinta antideslizante
10	1696186M93		1	Box, Storage	Coffre	Portaobjetos
11	3505771M1	M10 x 25	2	Screw	Vis	Tornillo
12	390734X1	M10	2	Washer	Rondelle	Arandela
13	1440329X1	M10	2	Nut, Lock	Écrou de blocage	Tuerca de retención
14	6109251M1		1	Cover	Cache	Tapa
15	6109252M1		1	Sheet	Tôle	Chapa
16	3001163X1	M5 x 16	3	Screw	Vis	Tornillo
17	3019560X1		3	Washer	Rondelle	Arandela
18	6110155M91	Front Console	1	Harness Assy	Ensemble de faisceau	Haz, Conj.

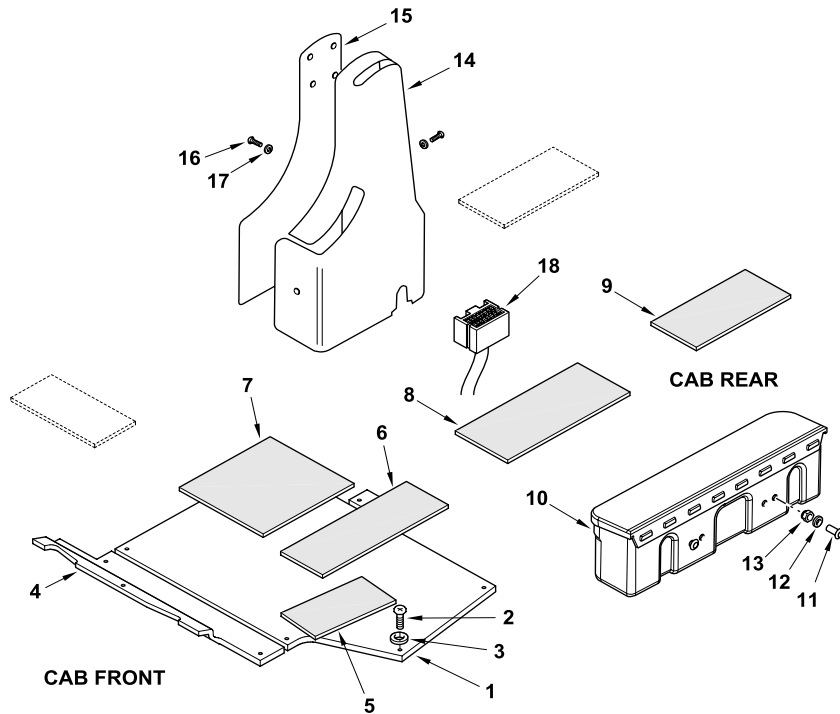

880
 TX760B TX860B
 TX870B

832 834 842 844

47016C02.1

6199042M3

1

Jan-06

Cab Trim
Habillage de Cabine
Guarnición de cabina

Windscreen Wiper
Essuie-Glace
Limpiaparabrisas

C-47010-04.1-A

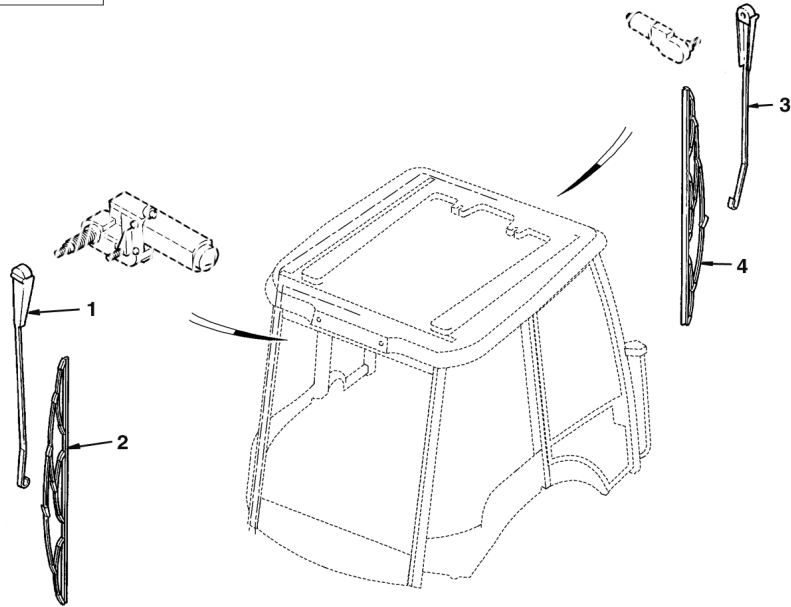

1	1473848M92		1	Arm, Wiper	Bras d'essuie-glace	Brazo limpiaparabrisas
2	1473847M91		1	Blade, Wiper	Balai d'essuie-glace	Escobilla limpiaparabr.
3	3512477M91	400 mm	1	Arm, Wiper	Bras d'essuie-glace	Brazo limpiaparabrisas
4	1473847M91		1	Blade, Wiper	Balai d'essuie-glace	Escobilla limpiaparabr.



820 860 970
 TX760B TX860B
 TX870B

801 803 805 807 809 811 813 815 817 922 923

47010C04.1

6199042M3

1

Jan-06

Cab Trim
Habillage de Cabine
Guarnición de cabina

Windscreen Wiper
Essuie-Glace
Limpiaparabrisas

C-47011-04.1-A

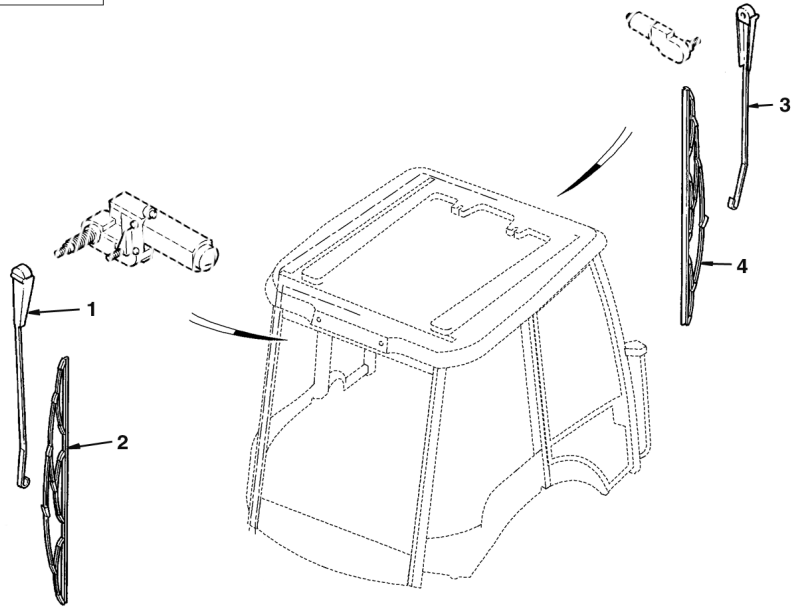

1	1473848M92		1	Arm, Wiper	Bras d'essuie-glace	Brazo limpiaparabrisas
2	1473847M91		1	Blade, Wiper	Balai d'essuie-glace	Escobilla limpiaparabr.
3	3512477M91	400 mm	1	Arm, Wiper	Bras d'essuie-glace	Brazo limpiaparabrisas
4	1473847M91		1	Blade, Wiper	Balai d'essuie-glace	Escobilla limpiaparabr.



860 970
 TX860B TX870B

821 823 825 921 922 923

47011C04.1

6199042M3

1

Jan-06

Cab Trim
Habillage de Cabine
Guarnición de cabina

Windscreen Wiper
Essuie-Glace
Limpiaparabrisas

C-47014-04.1-A

1	1473848M92		1	Arm, Wiper	Bras d'essuie-glace	Brazo limpiaparabrisas
2	1473847M91		1	Blade, Wiper	Balai d'essuie-glace	Escobilla limpiaparabr.
3	3512477M91	400 mm	1	Arm, Wiper	Bras d'essuie-glace	Brazo limpiaparabrisas
4	1473847M91		1	Blade, Wiper	Balai d'essuie-glace	Escobilla limpiaparabr.

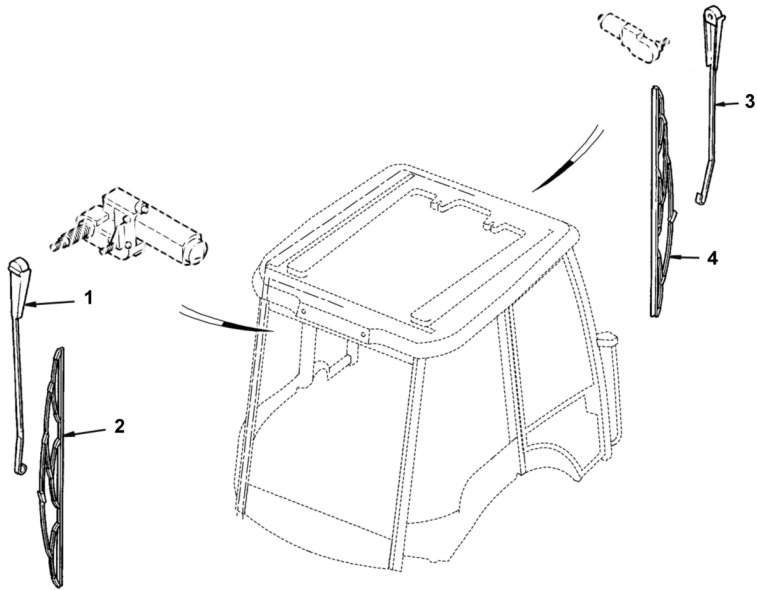

880
 TX760B TX860B
 TX870B

831 833 841 843 845 851

47014C04.1

6199042M3

1

Jan-06

Cab Trim
Habillage de Cabine
Guarnición de cabina

Windscreen Wiper
Essuie-Glace
Limpiaparabrisas

C-47015-04.1-A

1	1473848M92		1	Arm, Wiper	Bras d'essuie-glace	Brazo limpiaparabrisas
2	1473847M91		1	Blade, Wiper	Balai d'essuie-glace	Escobilla limpiaparabr.
3	3512477M91	400 mm	1	Arm, Wiper	Bras d'essuie-glace	Brazo limpiaparabrisas
4	1473847M91		1	Blade, Wiper	Balai d'essuie-glace	Escobilla limpiaparabr.

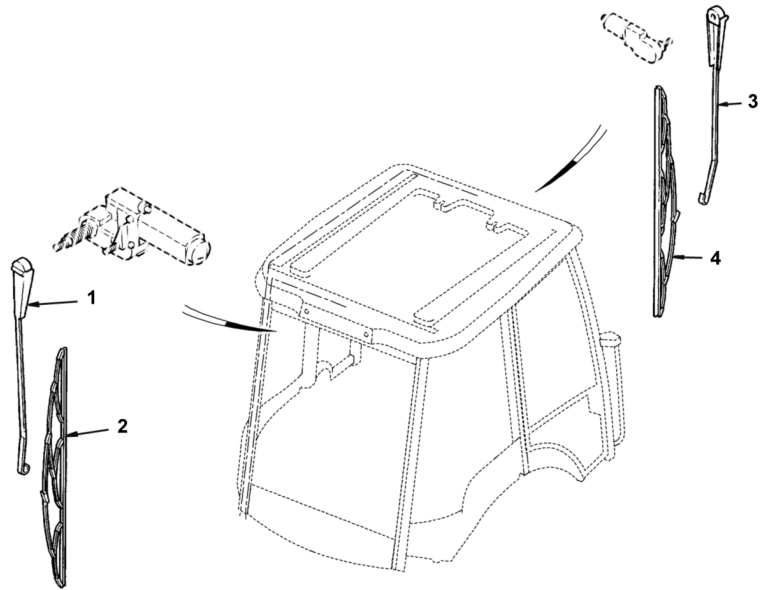

880 980
 TX860B TX870B
 TX970B

841 843 845 851 853 855 931 932

47015C04.1

6199042M3

1

Jan-06

Control Box
Boîte de Contrôle
Caja de control

Control Pedals
Pédales de Commande
Pedali de control

C-41010-02.1-B

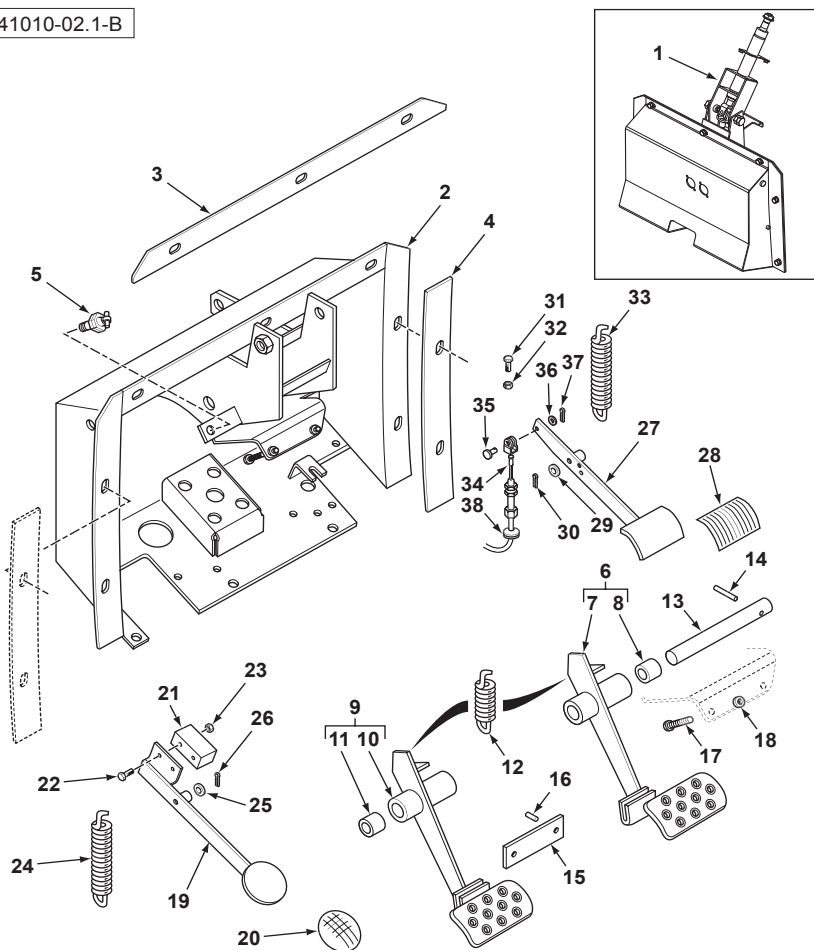

1	6110095M91		Continued	1	Control Box Assy	Ensemble boîte comm.	Caja de mando, Conj.
2	6110093M91	1		1	Control Box	Boîte de commande	Caja de mando
3	6100819M1	1		1	Seal	Joint	Junta
4	6100820M1	1		2	Seal	Joint	Junta
5	6107867M91	1	Brake light	1	Switch Assy	Ensemble commutat.	Conmutador, Conj.
6	6110083M91	1		1	Pedal Assy	Ensemble de pédale	Pedal, Conj.
7		6	▶ Ref. 6	1	Pedal Assy	Ensemble de pédale	Pedal, Conj.
8	1469497M1	6		2	Bushing	Bague	Anillo
9	6110084M91	1	◀ Ref. 9	1	Pedal Assy	Ensemble de pédale	Pedal, Conj.
10		9	▶ Ref. 9	1	Pedal Assy	Ensemble de pédale	Pedal, Conj.
11	1469497M1	9		2	Bushing	Bague	Anillo
12	1680157M2	1		2	Spring	Ressort	Muelle
13	6106570M2	1		1	Shaft	Arbre	Árbol
14	339135X1	1		1	Pin	Axe	Pasador
15	6108795M1	1		1	Latch	Loquet	Picaporte
16	357609X1	1		2	Pin	Axe	Pasador
17	390992X1	1	M8 x 50	2	Bolt	Boulon	Perno
18	339169X1	1	M8	2	Nut	Écrou	Tuerca
19	6109888M91	1		1	Pedal Assy	Ensemble de pédale	Pedal, Conj.
20	6100584M1	1		1	Pad, Anti Slip	Plaque, anti-dérapant	Cinta antideslizante
21	3518656M91	1		1	Switch	Contacteur	Contactar
22	3522433M2	1	M3 x 35	2	Screw	Vis	Tornillo
23	391216X1	1	M3	2	Nut	Écrou	Tuerca
24	1470592M1	1		1	Spring	Ressort	Muelle
25	390735X1	1	M12	1	Washer	Rondelle	Arandela
26	1442965X1	1	M4 x 25	1	Pin, Split	Goupille	Pasador
27	6109887M91	1		1	Pedal, Accelerator	Pédale d'accélérateur	Pedal de acelerador
28	6100585M1	1		1	Pad, Anti Slip	Plaque, anti-dérapant	Cinta antideslizante
29	390735X1	1	M12	1	Washer	Rondelle	Arandela
30	1442965X1	1	M4 x 25	1	Pin, Split	Goupille	Pasador
31	339337X1	1	M8 x 30	2	Bolt	Boulon	Perno
32	392309X1	1	M8	2	Nut	Écrou	Tuerca
33	1470592M1	1		1	Spring	Ressort	Muelle
34	6110669M92	1		1	Cable Assy	Ensemble de câble	Cable, Conj.
35	195446M1	1		1	Pin	Axe	Pasador
36	353753X1	1		1	Washer	Rondelle	Arandela
37	354039X1	1		1	Pin, Split	Goupille	Pasador
38	6102367M1	1		1	Grommet	Passe-fil	Pasa cable



820 860 880 970 980
 TX760B TX860B
 TX870B TX970B

801 802 803 804 805 806 807 808 809 810 811 812 813 814 815 816 817 821 822
 823 824 825 831 832 833 834 841 842 843 844 845 851 852 853 854 855 921 922
 923 931 932

41010C02.1

6199042M3

1

Jan-06

Control Box
Boîte de Contrôle
Caja de control

Hydraulics
Hydraulique
hidráulico

C-41010-03.1-A

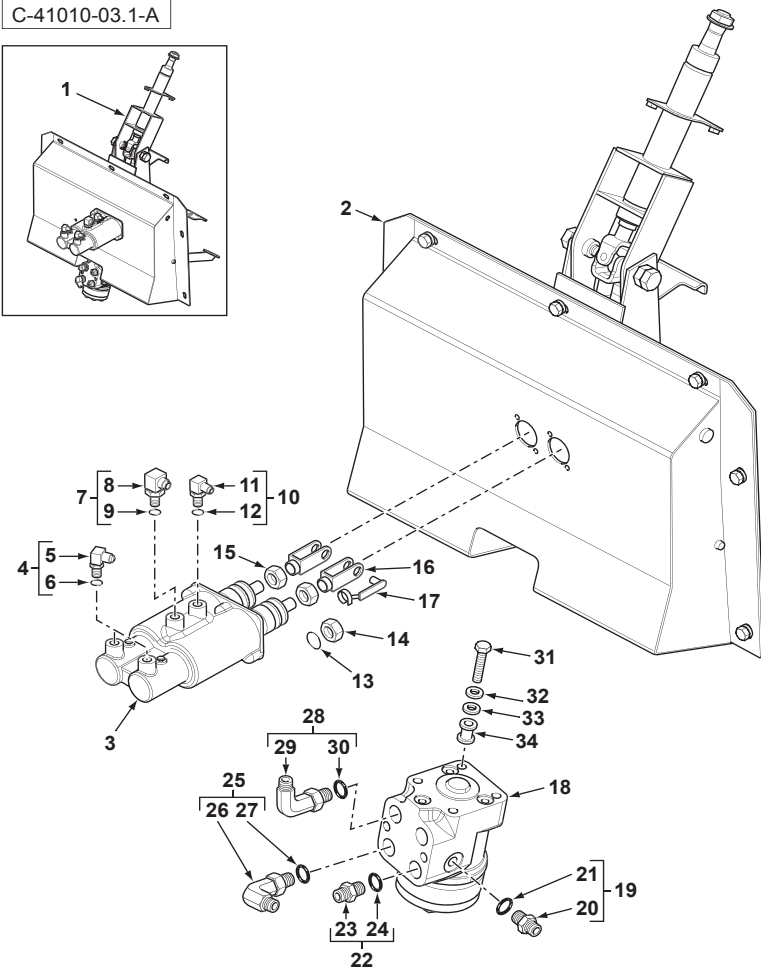
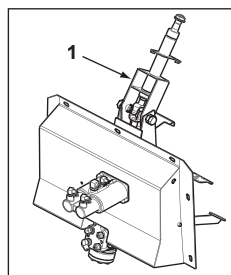

1	6110095M91		Continued	1	Control Box Assy	Ensemble boîte comm.	Caja de mando, Conj.
2		1	➤ Ref. 1	1	Control Box	Boîte de commande	Caja de mando
3	6103425M91	1	👁 Service Brakes	1	Cylinder, Master	Maître-cylindre	Cilindro principal
4		1	(A) 👁 [Service Brakes]	2	Elbow	Coude	Codo
5		4	➤ Ref. 4	1	Elbow	Coude	Codo
6		4	➤ Ref. 4	1	O-Ring	Joint torique	Junta de tipo O
7	3019651X91	1		1	Elbow, 90°	Coude à 90°	Codo, 90°
8		7	➤ Ref. 7	1	Elbow	Coude	Codo
9		7	➤ Ref. 7	1	O-Ring	Joint torique	Junta de tipo O
10	3019694X91	1		1	Elbow, 90°	Coude à 90°	Codo, 90°
11		10	➤ Ref. 10	1	Elbow	Coude	Codo
12		10	➤ Ref. 10	1	O-Ring	Joint torique	Junta de tipo O
13	385361X1	1	M8	4	Washer	Rondelle	Arandela
14	394367X1	1	M8	4	Nut, Lock	Écrou de blocage	Tuerca de retención
15	3009694X1	1	M10	2	Nut, Lock	Écrou de blocage	Tuerca de retención
16	3521833M1	1		2	Clevis	Chape	Brida
17	3521834M1	1		2	Pin, Clevis	Axe de chape	Eje de brida
18	6109844M91	1	👁 Steering System	1	Pump, Steering	Pompe, direction	Bomba, Dirección
19	358741X91	1		1	Union	Union	Unión
20		19	➤ Ref. 19	1	Union	Union	Unión
21	831495M1	19		1	O-Ring	Joint torique	Junta de tipo O
22	360202X91	1		2	Union	Union	Unión
23		22	➤ Ref. 22	1	Union	Union	Unión
24	1852568M1	22		1	O-Ring	Joint torique	Junta de tipo O
25	358762X91	1		1	Elbow	Coude	Codo
26		25	➤ Ref. 25	1	Elbow	Coude	Codo
27	831497M1	25		1	O-Ring	Joint torique	Junta de tipo O
28	364415X91	1		1	Elbow	Coude	Codo
29		28	➤ Ref. 28	1	Elbow	Coude	Codo
30		28	➤ Ref. 28	1	O-Ring	Joint torique	Junta de tipo O
31	3009494X1	1	M10 x 35	4	Screw	Vis	Tornillo
32	339376X1	1	M10	4	Washer, Lock	Rondelle de blocage	Arandela de freno
33	390597X1	1	M10	4	Washer	Rondelle	Arandela
34	3507736M1	1		4	Stanchion	Montant	Montante

A No longer serviced
 Pas fournies
 No suministradas



820 860 880 970 980
 TX760B TX860B
 TX870B TX970B

801 802 803 804 805 806 807 808 809 810 811 812 813 814 815 816 817 821 822
 823 824 825 831 832 833 834 841 842 843 844 845 851 852 853 854 855 921 922
 923 931 932

41010C03.1

6199042M3

1

Jan-06

Control Box
Boîte de Contrôle
Caja de control

Steering
Direction
Dirección

C-41010-04.1-B

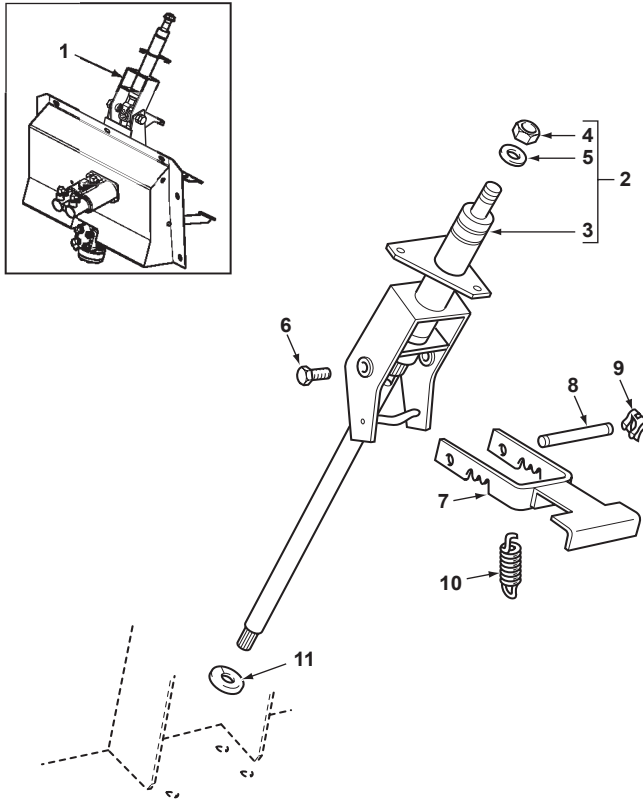

1	6110095M91		Continued	1	Control Box Assy	Ensemble boîte comm.	Caja de mando, Conj.
2	6109254M91	1		1	Column, Steering	Colonne de direction	Columna, Dirección
3		2	Ref. 2	1	Shaft	Arbre	Árbol
4	392913X1	2		1	Washer	Rondelle	Arandela
5	1441246X1	2	M20	1	Nut	Écrou	Tuerca
6	1611049M1	1		2	Screw	Vis	Tornillo
7	6101155M93	1		1	Bracket	Patte de fixation	Pata de fijación
8	3521918M2	1		1	Pin	Axe	Pasador
9	3521461M1	1	M10	2	Clip	Clip	Clip
10	3522399M1	1		1	Spring	Ressort	Muelle
11	6110526M1	1		1	Seal	Joint	Junta



820 860 880 970 980
TX760B TX860B
TX870B TX970B

801 802 803 804 805 806 807 808 809 810 811 812 813 814 815 816 817 821 822
823 824 825 831 832 833 834 841 842 843 844 845 851 852 853 854 855 921 922
923 931 932

41010C04.1

6199042M3

1

Jan-06

Control Box
Boîte de Contrôle
Caja de control

Installation
Montage
Instalación

C-41010-01.1-A

1	6110095M91		1	Control Box Assy	Ensemble boîte comm.	Caja de mando, Conj.
2	339123X1	M8 x 20	3	Bolt	Boulon	Perno
3	385361X1	M8	3	Washer	Rondelle	Arandela
4	1473135M1		2	Plug	Bouchon	Tapón
5	339011X1	M8 x 45	4	Bolt	Boulon	Perno
6	385361X1	M8	4	Washer	Rondelle	Arandela

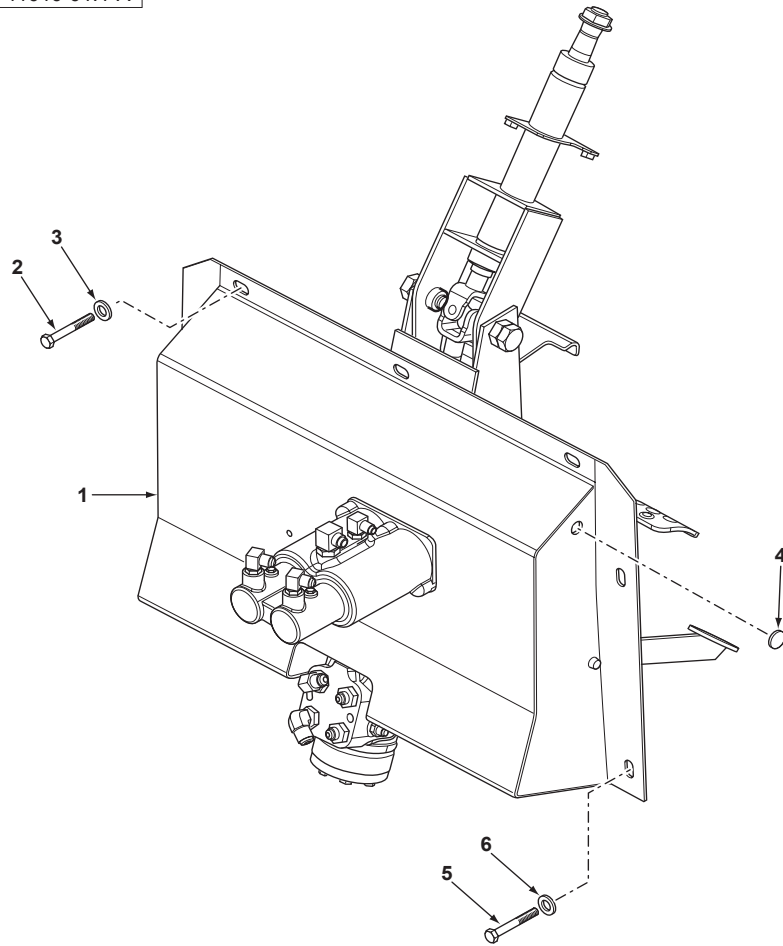

820 860 880 970 980
 TX760B TX860B
 TX870B TX970B

801 802 803 804 805 806 807 808 809 810 811 812 813 814 815 816 817 821 822
 823 824 825 831 832 833 834 841 842 843 844 845 851 852 853 854 855 921 922
 923 931 932

41010C01.1

6199042M3

1

Jan-06

Front Console
 Console Avant
 Consola delantera

Rops
 Rops
 Rops

C-55001-01.1-A

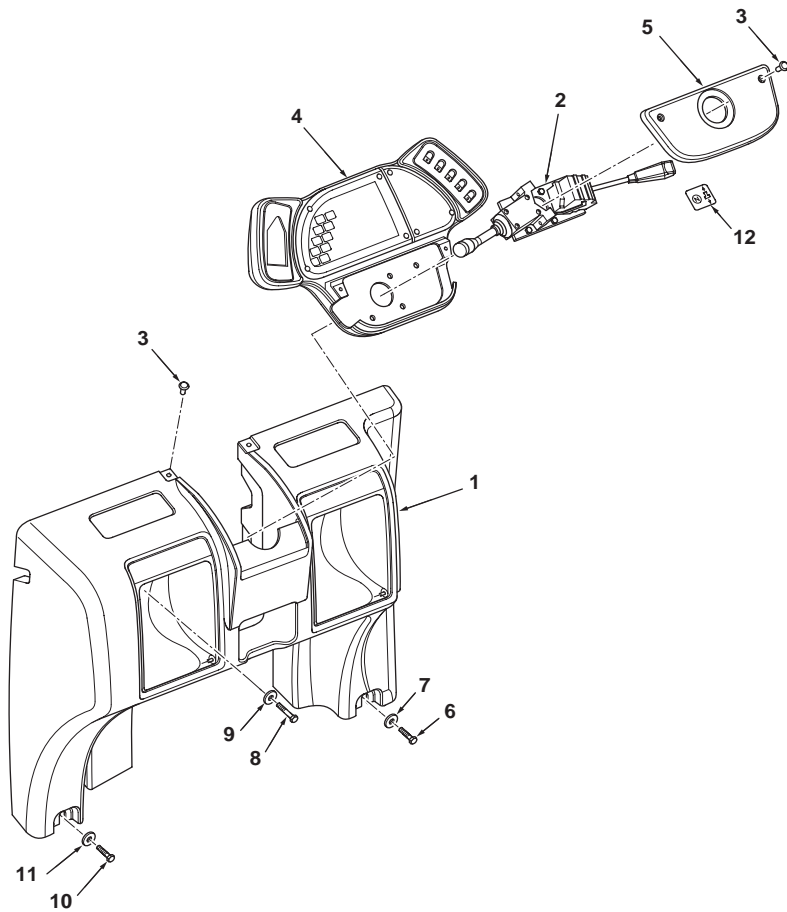

1	6108166M92	55001C02.1	1	Console	Console	Consola
2		55001C04.1	1	Switch, Selector	Commutateur	Conmutador
3	6101591M1	Plastic	4	Rivet	Rivet	Remache
4		55001C03.1	1	Panel, Instrument	Tableau de bord	Tablero instrumentos
5	6099518M1		1	Cover Sheet	Couvercle	Tapa
6	339009X1	M8 x 35	1	Screw	Vis	Tornillo
7	6101768M1	M8	1	Washer	Rondelle	Arandela
8	339123X1	M8 x 20	2	Bolt	Boulon	Perno
9	6101768M1	M8	2	Washer	Rondelle	Arandela
10	339009X1	M8 x 35	1	Screw	Vis	Tornillo
11	6101768M1	M8	1	Washer	Rondelle	Arandela
12	6101914M1		1	Decal	Adhésif	Adhesivo



820
 TX760B TX860B
 TX870B

802 806 810 812

55001C01.1

6199042M3

1

Jan-06

Front Console
 Console Avant
 Consola delantera

Rops
 Rops
 Rops

C-55001-02.1-A

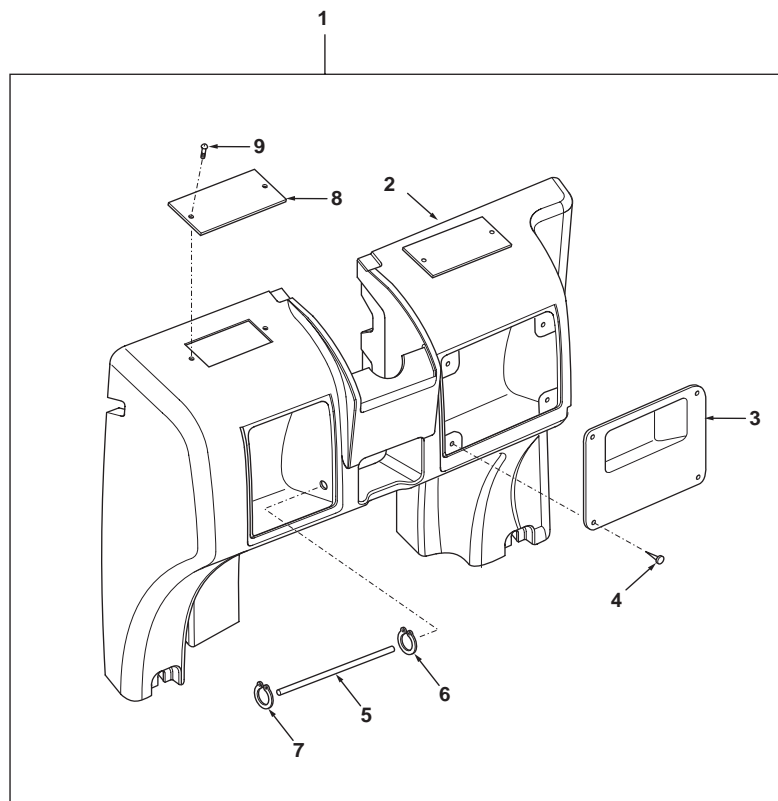

1	6108166M92		55001C01.1	1	Console	Console	Consola
2	6106858M2	1		1	Console	Console	Consola
3	6106812M2	1		1	Cover	Cache	Tapa
4	3521303M3	1		4	Fastener	Attache	Enganche
5	6108289M1	1		1	Rail	Rail	Carril
6	3000115X1	1		1	Circlip	Segment d'arrêt	Circlip
7	3000115X1	1		1	Circlip	Segment d'arrêt	Circlip
8	6108290M1	1		2	Plate	Plaque	Placa
9	3522735M4	1	M3 x 16	4	Screw	Vis	Tornillo



820
 TX760B TX860B
 TX870B

802 806 810 812

55001C02.1

6199042M3

1

Jan-06

Front Console
 Console Avant
 Consola delantera

Cab
 Cabine
 Cabina

C-55002-01.1-A

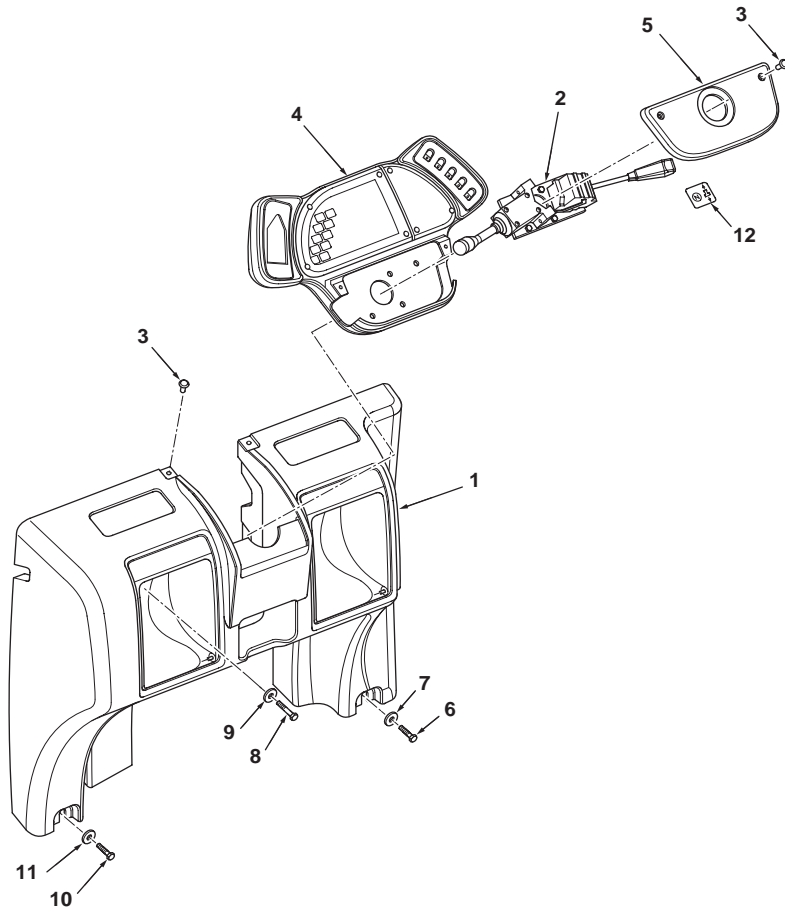

1	6106473M91	55002C02.1	1	Console	Console	Consola
2		55002C04.1	1	Switch, Selector	Commutateur	Conmutador
3	6101591M1	Plastic	4	Rivet	Rivet	Remache
4		55002C03.1	1	Panel, Instrument	Tableau de bord	Tablero instrumentos
5	6099518M1		1	Cover Sheet	Couvercle	Tapa
6	339009X1	M8 x 35	1	Screw	Vis	Tornillo
7	6101768M1	M8	1	Washer	Rondelle	Arandela
8	339123X1	M8 x 20	2	Bolt	Boulon	Perno
9	6101768M1	M8	2	Washer	Rondelle	Arandela
10	339009X1	M8 x 35	1	Screw	Vis	Tornillo
11	6101768M1	M8	1	Washer	Rondelle	Arandela
12	6101914M1		1	Decal	Adhésif	Adhesivo



820 860
 TX760B TX860B
 TX870B

801 803 805 809 811 813 815

55002C01.1

6199042M3

1

Jan-06

Front Console
 Console Avant
 Consola delantera

Cab
 Cabine
 Cabina

C-55002-02.1-A

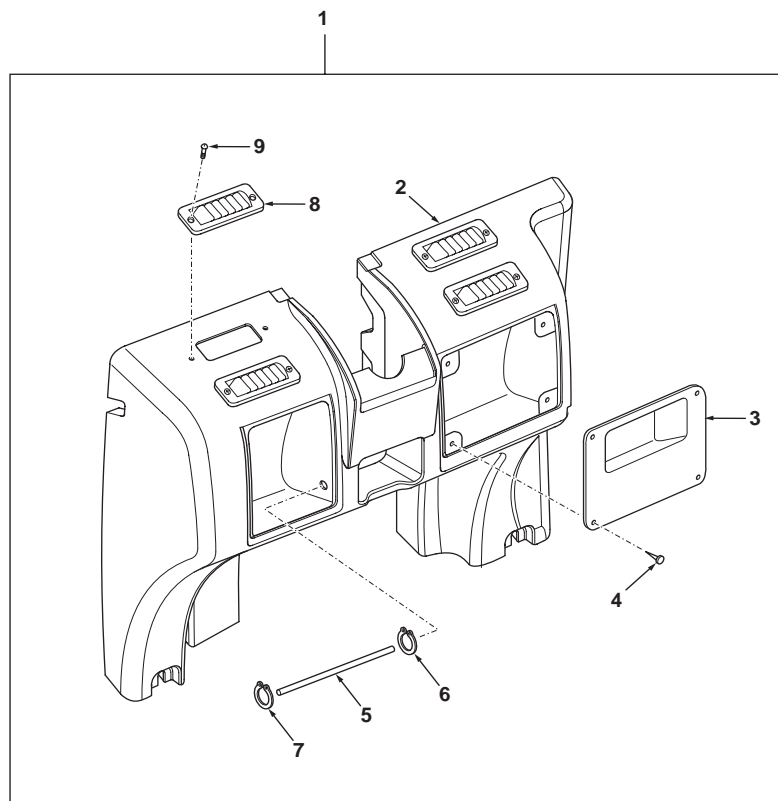

1	6106473M91		55002C01.1	1	Console	Console	Consola
2	6106671M1	1		1	Console	Console	Consola
3	6106812M2	1		1	Cover	Cache	Tapa
4	3521303M3	1		4	Fastener	Attache	Enganche
5	6108289M1	1		1	Rail	Rail	Carril
6	3000115X1	1		1	Circlip	Segment d'arrêt	Circlip
7	3000115X1	1		1	Circlip	Segment d'arrêt	Circlip
8	3516231M1	1		5	Diffuser	Diffuseur	Difusor
9	3522735M4	1	M3 x 16	10	Screw	Vis	Tornillo



820 860
 TX760B TX860B
 TX870B

801 803 805 809 811 813 815

55002C02.1

6199042M3

1

Jan-06

Front Console
 Console Avant
 Consola delantera

Rops
 Rops
 Rops

C-55003-01.1-A

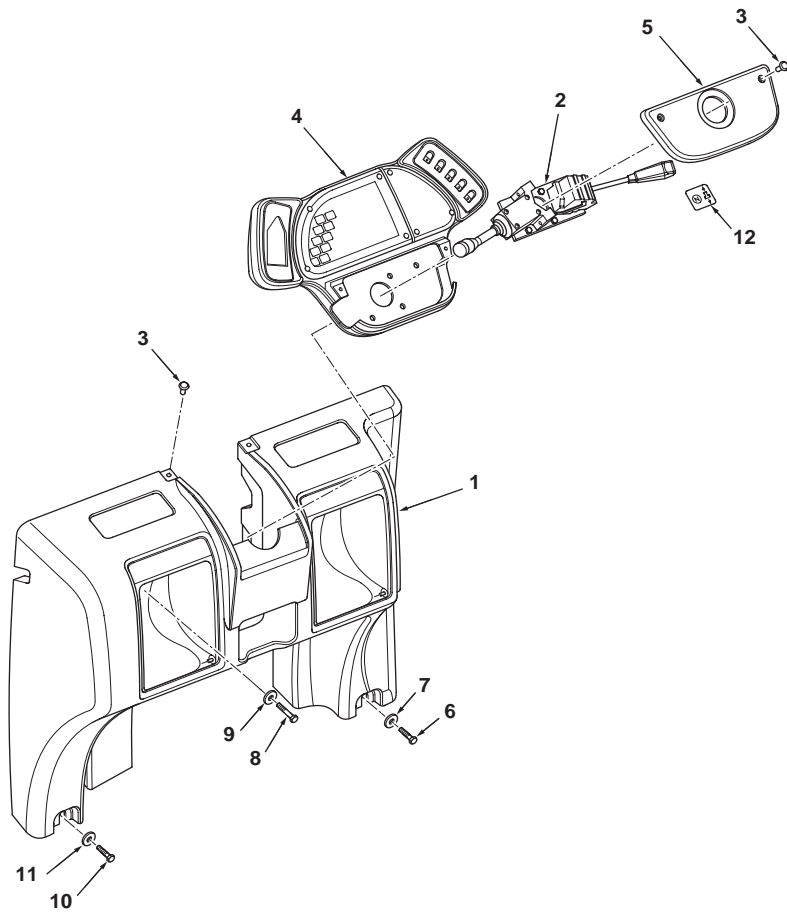

1	6108166M92	55003C02.1	1	Console	Console	Consola
2		55003C04.1	1	Switch, Selector	Commutateur	Conmutador
3	6101591M1	Plastic	4	Rivet	Rivet	Remache
4		55003C03.1	1	Panel, Instrument	Tableau de bord	Tablero instrumentos
5	6099518M1		1	Cover Sheet	Couvercle	Tapa
6	339009X1	M8 x 35	1	Screw	Vis	Tornillo
7	6101768M1	M8	1	Washer	Rondelle	Arandela
8	339123X1	M8 x 20	2	Bolt	Boulon	Perno
9	6101768M1	M8	2	Washer	Rondelle	Arandela
10	339009X1	M8 x 35	1	Screw	Vis	Tornillo
11	6101768M1	M8	1	Washer	Rondelle	Arandela
12	6101914M1		1	Decal	Adhésif	Adhesivo



820 860 880
 TX760B TX860B
 TX870B

804 808 814 816 832 834 842 844

55003C01.1

6199042M3

1

Jan-06

Front Console
 Console Avant
 Consola delantera

Rops
 Rops
 Rops

C-55003-02.1-A

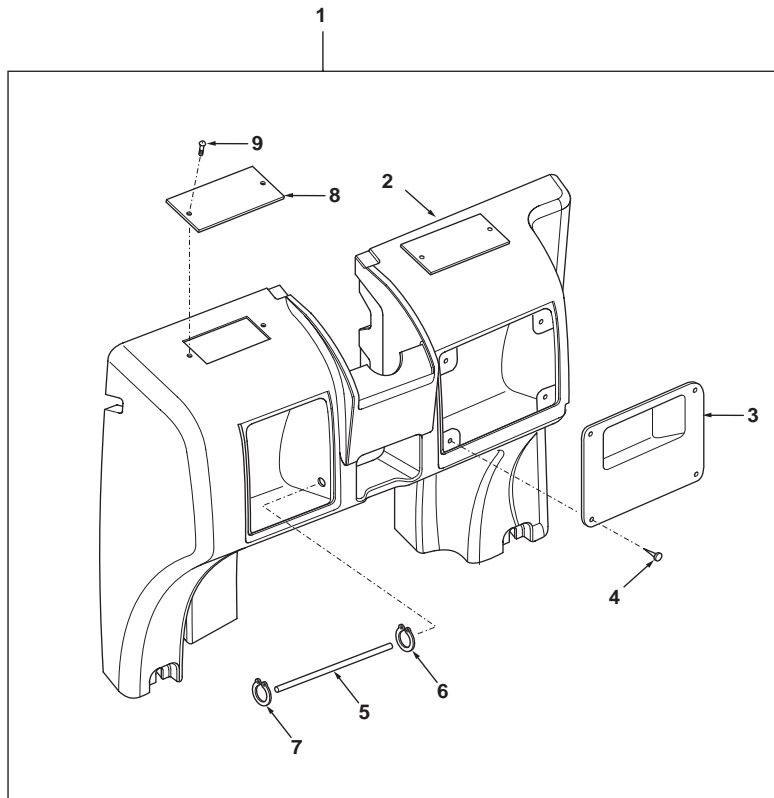

1	6108166M92		55003C01.1	1	Console	Console	Consola
2	6106858M2	1		1	Console	Console	Consola
3	6106812M2	1		1	Cover	Cache	Tapa
4	3521303M3	1		4	Fastener	Attache	Eganche
5	6108289M1	1		1	Rail	Rail	Carril
6	3000115X1	1		1	Circlip	Segment d'arrêt	Circlip
7	3000115X1	1		1	Circlip	Segment d'arrêt	Circlip
8	6108290M1	1		2	Plate	Plaque	Placa
9	3522735M4	1	M3 x 16	4	Screw	Vis	Tornillo



820 860 880
 TX760B TX860B
 TX870B

804 808 814 816 832 834 842 844

55003C02.1

6199042M3

1

Jan-06

Front Console
Console Avant
Consola delantera

Rops
Rops
Rops

C-55004-01.1-A

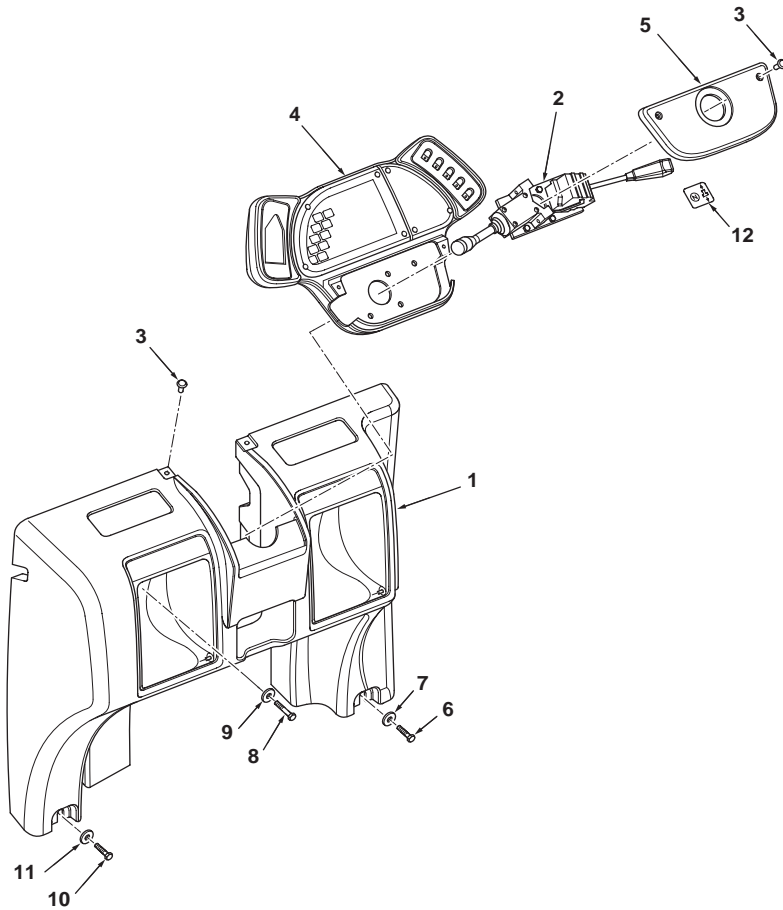

1	6108166M92	55004C02.1	1	Console	Console	Consola
2		55004C04.1	1	Switch, Selector	Commutateur	Conmutador
3	6101591M1	Plastic	4	Rivet	Rivet	Remache
4		55004C03.1	1	Panel, Instrument	Tableau de bord	Tablero instrumentos
5	6099518M1		1	Cover Sheet	Couvercle	Tapa
6	339009X1	M8 x 35	1	Screw	Vis	Tornillo
7	6101768M1	M8	1	Washer	Rondelle	Arandela
8	339123X1	M8 x 20	2	Bolt	Boulon	Perno
9	6101768M1	M8	2	Washer	Rondelle	Arandela
10	339009X1	M8 x 35	1	Screw	Vis	Tornillo
11	6101768M1	M8	1	Washer	Rondelle	Arandela
12	6101914M1		1	Decal	Adhésif	Adhesivo



820 860 880
TX760B TX860B
TX870B

804 808 814 816 832 834 842 844

55004C01.1

6199042M3

1

Jan-06

Front Console
 Console Avant
 Consola delantera

Rops
 Rops
 Rops

C-55004-02.1-A

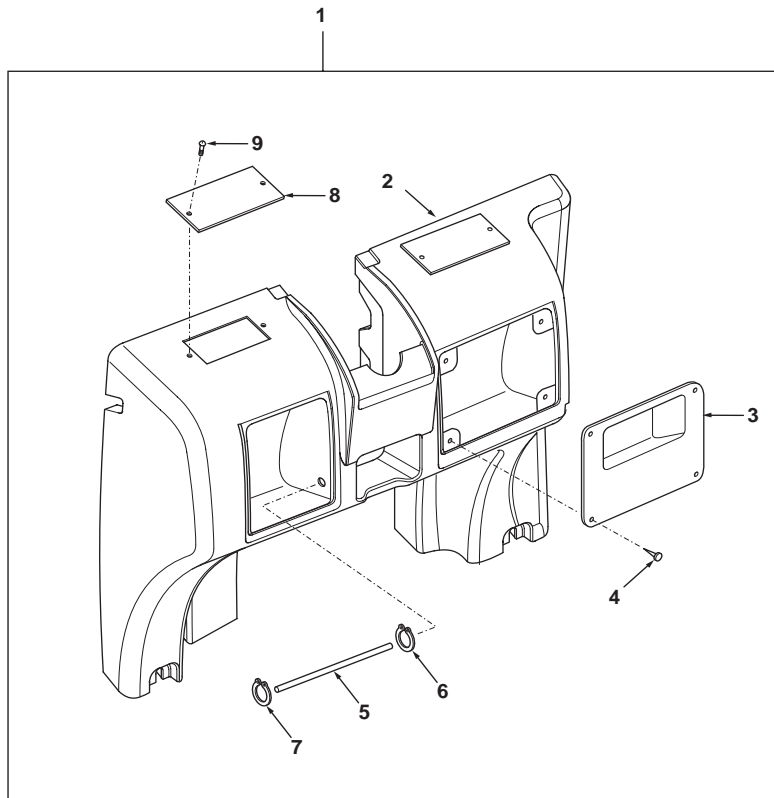

1	6108166M92		55004C01.1	1	Console	Console	Consola
2	6106858M2	1		1	Console	Console	Consola
3	6106812M2	1		1	Cover	Cache	Tapa
4	3521303M3	1		4	Fastener	Attache	Enganche
5	6108289M1	1		1	Rail	Rail	Carril
6	3000115X1	1		1	Circlip	Segment d'arrêt	Circlip
7	3000115X1	1		1	Circlip	Segment d'arrêt	Circlip
8	6108290M1	1		2	Plate	Plaque	Placa
9	3522735M4	1	M3 x 16	4	Screw	Vis	Tornillo



820 860 880
 TX760B TX860B
 TX870B

804 808 814 816 832 834 842 844

55004C02.1

6199042M3

1

Jan-06

Front Console
 Console Avant
 Consola delantera

Cab
 Cabine
 Cabina

C-55005-01.1-A

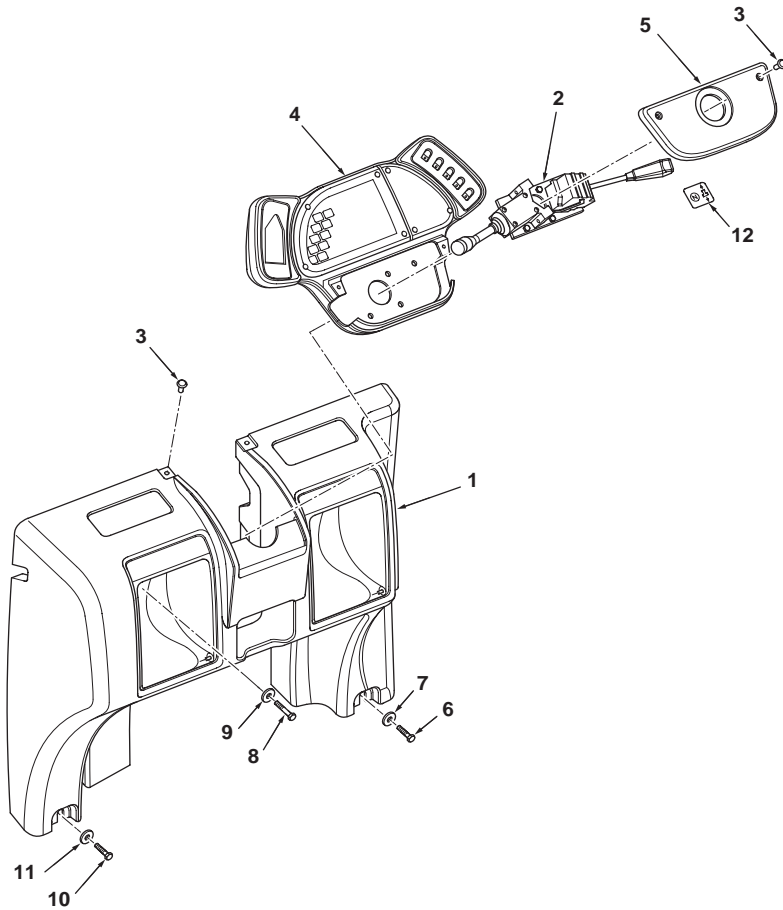

1	6106473M91	55005C02.1	1	Console	Console	Consola
2		55005C04.1	1	Switch, Selector	Commutateur	Conmutador
3	6101591M1	Plastic	4	Rivet	Rivet	Remache
4		55005C03.1	1	Panel, Instrument	Tableau de bord	Tablero instrumentos
5	6099518M1		1	Cover Sheet	Couvercle	Tapa
6	339009X1	M8 x 35	1	Screw	Vis	Tornillo
7	6101768M1	M8	1	Washer	Rondelle	Arandela
8	339123X1	M8 x 20	2	Bolt	Boulon	Perno
9	6101768M1	M8	2	Washer	Rondelle	Arandela
10	339009X1	M8 x 35	1	Screw	Vis	Tornillo
11	6101768M1	M8	1	Washer	Rondelle	Arandela
12	6101914M1		1	Decal	Adhésif	Adhesivo



820 860 880
 TX760B TX860B
 TX870B

803 807 813 815 817 831 833 841 843 845

55005C01.1

6199042M3

1

Jan-06

Front Console
 Console Avant
 Consola delantera

Cab
 Cabine
 Cabina

C-55005-02.1-A

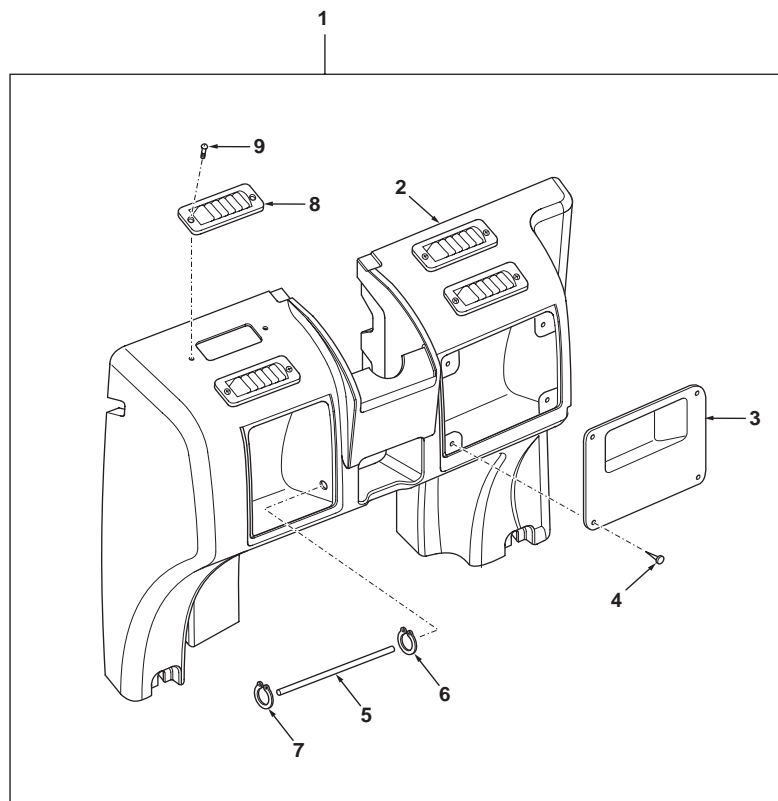

1	6106473M91		55005C01.1	1	Console	Console	Consola
2	6106671M1	1		1	Console	Console	Consola
3	6106812M2	1		1	Cover	Cache	Tapa
4	3521303M3	1		4	Fastener	Attache	Enganche
5	6108289M1	1		1	Rail	Rail	Carril
6	3000115X1	1		1	Circlip	Segment d'arrêt	Circlip
7	3000115X1	1		1	Circlip	Segment d'arrêt	Circlip
8	3516231M1	1		5	Diffuser	Diffuseur	Difusor
9	3522735M4	1	M3 x 16	10	Screw	Vis	Tornillo



820 860 880
 TX760B TX860B
 TX870B

803 807 813 815 817 831 833 841 843 845

55005C02.1

6199042M3

1

Jan-06

Front Console
 Console Avant
 Consola delantera

Cab
 Cabine
 Cabina

C-55006-01.1-A

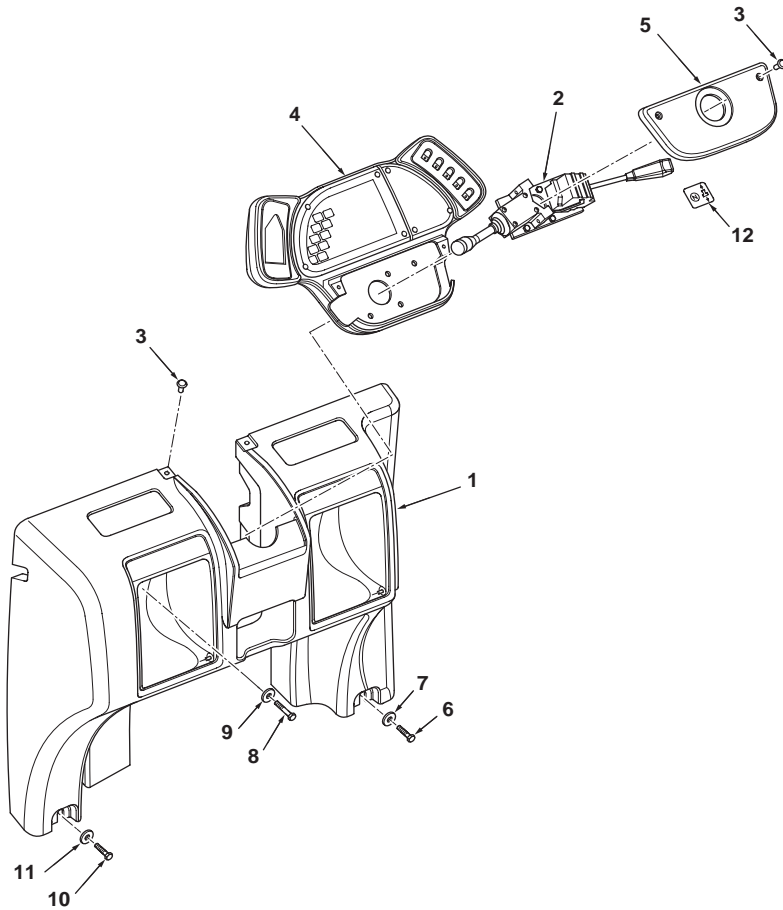

1	6106473M91	55006C02.1	1	Console	Console	Consola
2		55006C04.1	1	Switch, Selector	Commutateur	Conmutador
3	6101591M1	Plastic	4	Rivet	Rivet	Remache
4		55006C03.1	1	Panel, Instrument	Tableau de bord	Tablero instrumentos
5	6099518M1		1	Cover Sheet	Couvercle	Tapa
6	339009X1	M8 x 35	1	Screw	Vis	Tornillo
7	6101768M1	M8	1	Washer	Rondelle	Arandela
8	339123X1	M8 x 20	2	Bolt	Boulon	Perno
9	6101768M1	M8	2	Washer	Rondelle	Arandela
10	339009X1	M8 x 35	1	Screw	Vis	Tornillo
11	6101768M1	M8	1	Washer	Rondelle	Arandela
12	6101914M1		1	Decal	Adhésif	Adhesivo



820 860 880
 TX760B TX860B
 TX870B

803 807 813 815 817 831 833 841 843 845 851

55006C01.1

6199042M3

1

Jan-06

Front Console
 Console Avant
 Consola delantera

Cab
 Cabine
 Cabina

C-55006-02.1-A

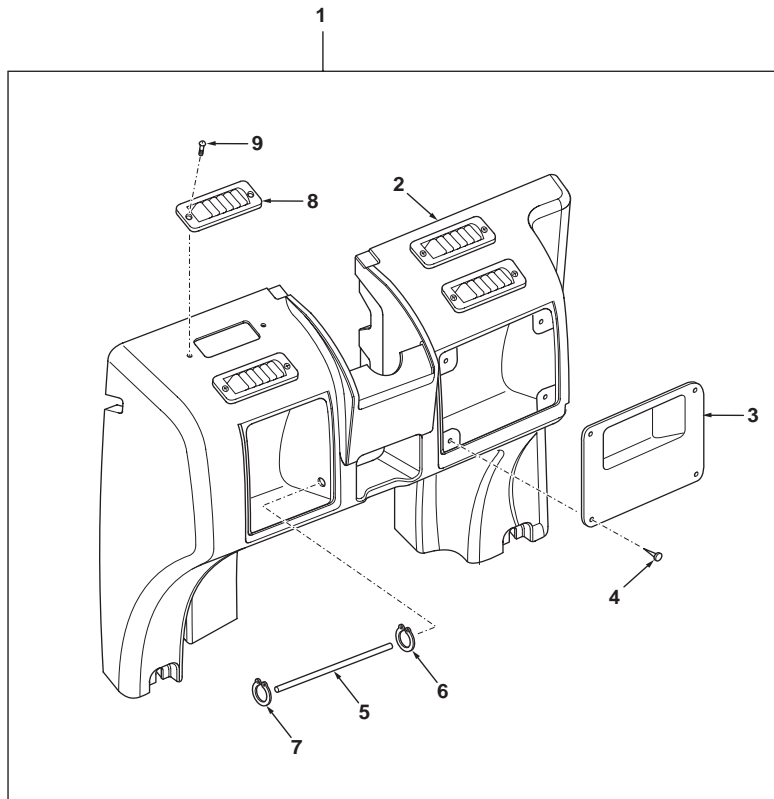

1	6106473M91		55006C01.1	1	Console	Console	Consola
2	6106671M1	1		1	Console	Console	Consola
3	6106812M2	1		1	Cover	Cache	Tapa
4	3521303M3	1		4	Fastener	Attache	Enganche
5	6108289M1	1		1	Rail	Rail	Carril
6	3000115X1	1		1	Circlip	Segment d'arrêt	Circlip
7	3000115X1	1		1	Circlip	Segment d'arrêt	Circlip
8	3516231M1	1		5	Diffuser	Diffuseur	Difusor
9	3522735M4	1	M3 x 16	10	Screw	Vis	Tornillo



820 860 880
 TX760B TX860B
 TX870B

803 807 813 815 817 831 833 841 843 845 851

55006C02.1

6199042M3

1

Jan-06

Front Console
 Console Avant
 Consola delantera

Cab
 Cabine
 Cabina

C-55009-01.1-A

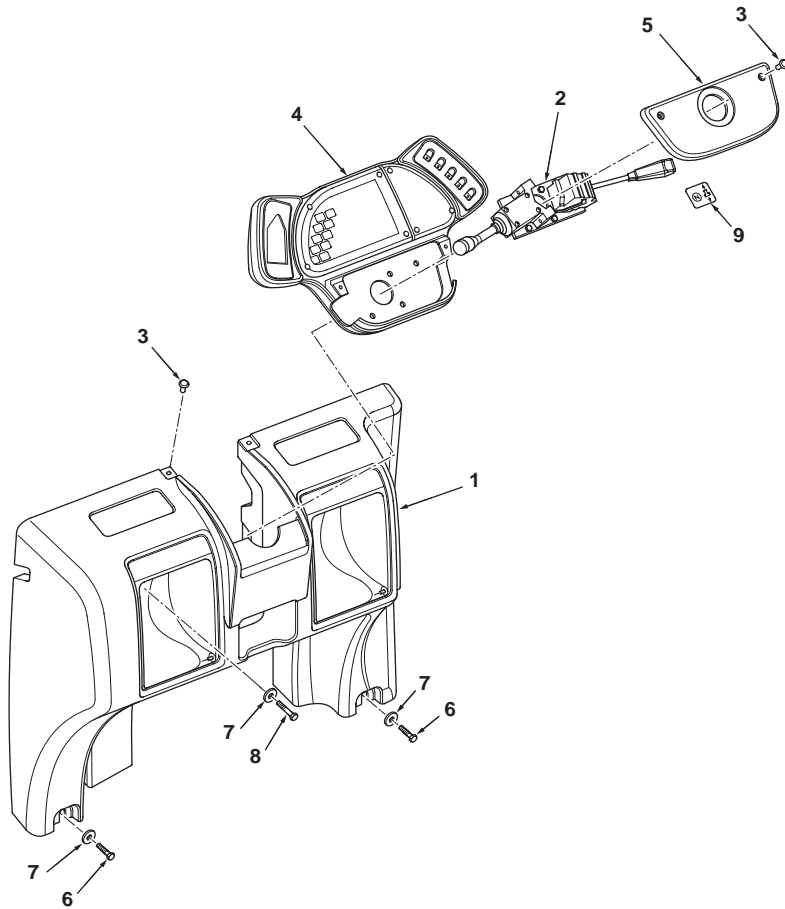

1	6106473M91	55009C02.1	1	Console	Console	Consola
2		55009C04.1	1	Switch, Selector	Commutateur	Conmutador
3	6101591M1	Plastic	4	Rivet	Rivet	Remache
4		55009C03.1	1	Panel, Instrument	Tableau de bord	Tablero instrumentos
5	6099518M1		1	Cover Sheet	Couvercle	Tapa
6	339009X1	M8 x 35	1	Screw	Vis	Tornillo
7	6101768M1	M8	2	Washer	Rondelle	Arandela
8	339123X1	M8 x 20	4	Bolt	Boulon	Perno
9	6101914M1		2	Decal	Adhésif	Adhesivo



860 880 970 980
 TX860B TX870B
 TX970B

821 823 825 841 843 845 851 853 855 921 922 923 931 932

55009C01.1

6199042M3

1

Jan-06

Front Console
 Console Avant
 Consola delantera

Cab
 Cabine
 Cabina

C-55009-02.1-A

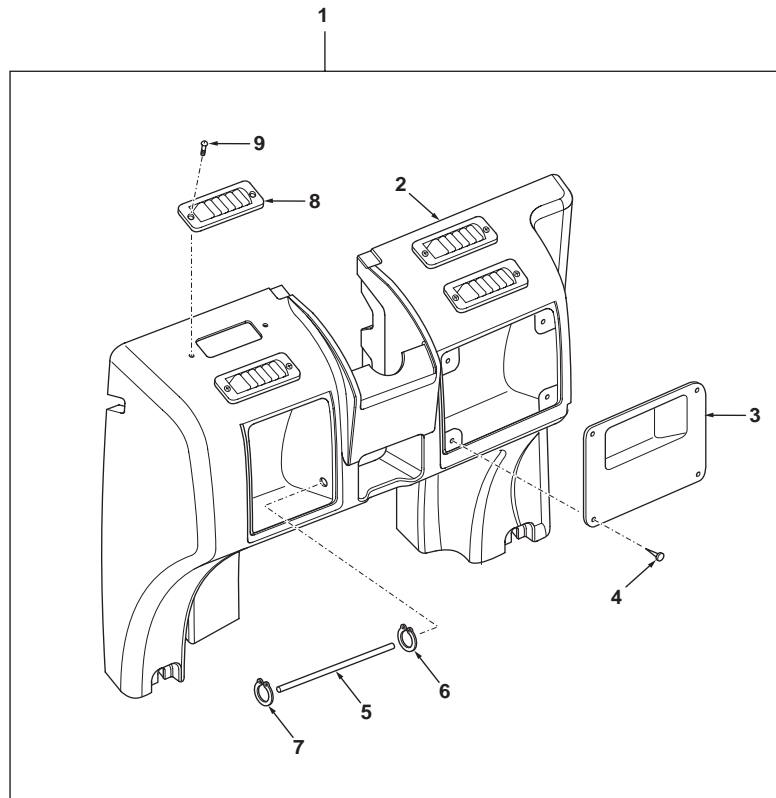

1	6106473M91		55009C01.1	1	Console	Console	Consola
2	6106671M1	1		1	Console	Console	Consola
3	6106812M2	1		1	Cover	Cache	Tapa
4	3521303M3	1		4	Fastener	Attache	Enganche
5	6108289M1	1		1	Rail	Rail	Carril
6	3000115X1	1		1	Circlip	Segment d'arrêt	Circlip
7	3000115X1	1		1	Circlip	Segment d'arrêt	Circlip
8	3516231M1	1		5	Diffuser	Diffuseur	Difusor
9	3522735M4	1	M3 x 16	10	Screw	Vis	Tornillo



860 880 970 980
 TX860B TX870B
 TX970B

821 823 825 841 843 845 851 853 855 921 922 923 931 932

55009C02.1

6199042M3

1

Jan-06

Front Console
 Console Avant
 Consola delantera

Cab
 Cabine
 Cabina

C-55010-01.1-A

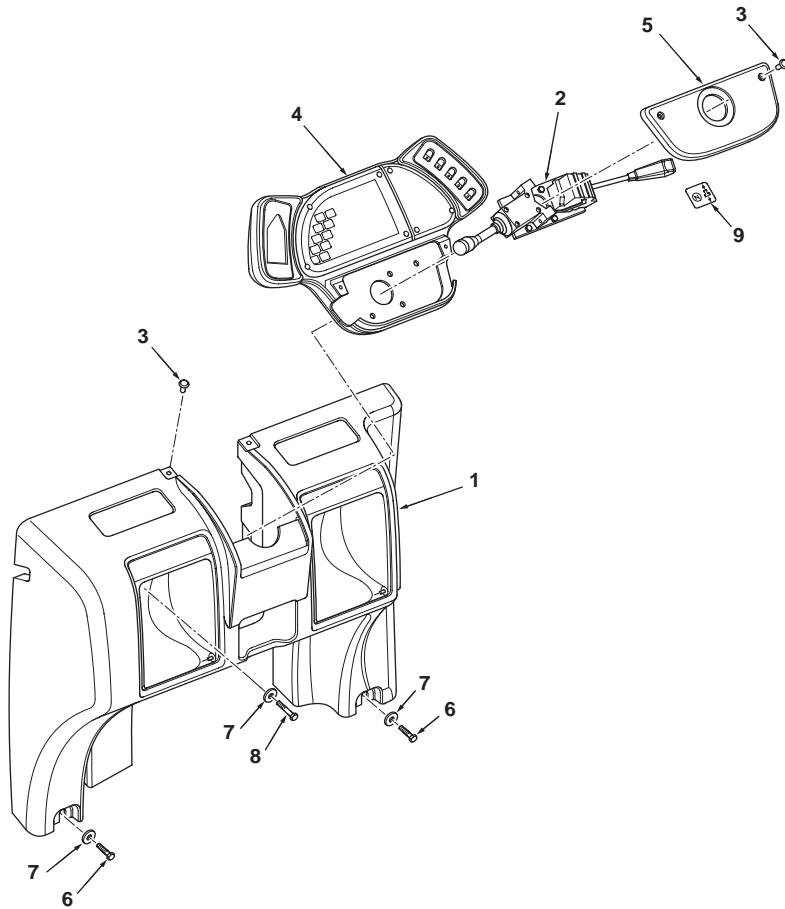

1	6106473M91	55010C02.1	1	Console	Console	Consola
2		55010C04.1	1	Switch, Selector	Commutateur	Conmutador
3	6101591M1	Plastic	4	Rivet	Rivet	Remache
4		55010C03.1	1	Panel, Instrument	Tableau de bord	Tablero instrumentos
5	6099518M1		1	Cover Sheet	Couvercle	Tapa
6	339009X1	M8 x 35	1	Screw	Vis	Tornillo
7	6101768M1	M8	2	Washer	Rondelle	Arandela
8	339123X1	M8 x 20	4	Bolt	Boulon	Perno
9	6101914M1		2	Decal	Adhésif	Adhesivo



860 880 970 980
 TX860B TX870B
 TX970B

821 823 825 851 853 855 921 922 923 931 932

55010C01.1

6199042M3

1

Jan-06

Front Console
Console Avant
Consola delantera

Cab
Cabine
Cabina

C-55010-02.1-A

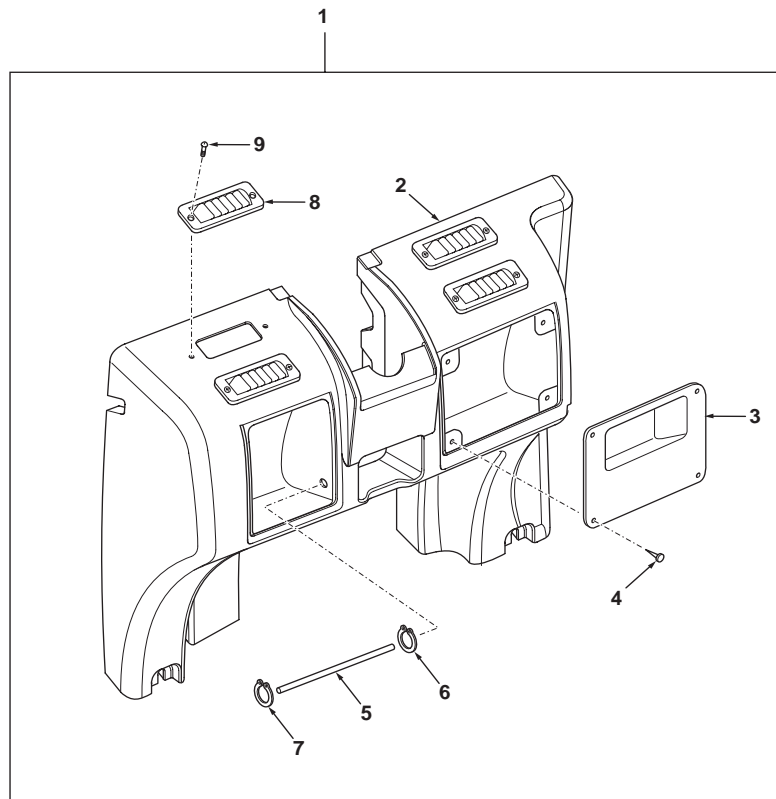

1	6106473M91		55010C01.1	1	Console	Console	Consola
2	6106671M1	1		1	Console	Console	Consola
3	6106812M2	1		1	Cover	Cache	Tapa
4	3521303M3	1		4	Fastener	Attache	Enganche
5	6108289M1	1		1	Rail	Rail	Carril
6	3000115X1	1		1	Circlip	Segment d'arrêt	Circlip
7	3000115X1	1		1	Circlip	Segment d'arrêt	Circlip
8	3516231M1	1		5	Diffuser	Diffuseur	Difusor
9	3522735M4	1	M3 x 16	10	Screw	Vis	Tornillo



860 880 970 980
TX860B TX870B
TX970B

821 823 825 851 853 855 921 922 923 931 932

55010C02.1

6199042M3

1

Jan-06

Front Console
 Console Avant
 Consola delantera

Forward/Reverse Switch
 Interrupteur de Marche Avant/Arrière
 Interruptor de marcha adelante / atrás

Rops
 Rops
 Rops

C-55001-04.1-A

1	3519823M91	55001C01.1 2	1	Switch, Selector	Commutateur	Conmutador
2	3009538X1	M5 x 35	2	Screw	Vis	Tornillo
3	6107120M91		1	Bracket Assy	Ensemble chaise palier	Cuchara, Conj.
4	339124X1	M8 x 16	6	Screw	Vis	Tornillo
5	1441494X1		2	Nut, Lock	Écrou de blocage	Tuerca de retención
6	390972X1	M8	3	Washer	Rondelle	Arandela
7	3516095M1		1	Switch, Selector	Commutateur	Conmutador
8	3007932X1	M5 x 12	1	Screw	Vis	Tornillo
9	3019560X1		2	Washer	Rondelle	Arandela

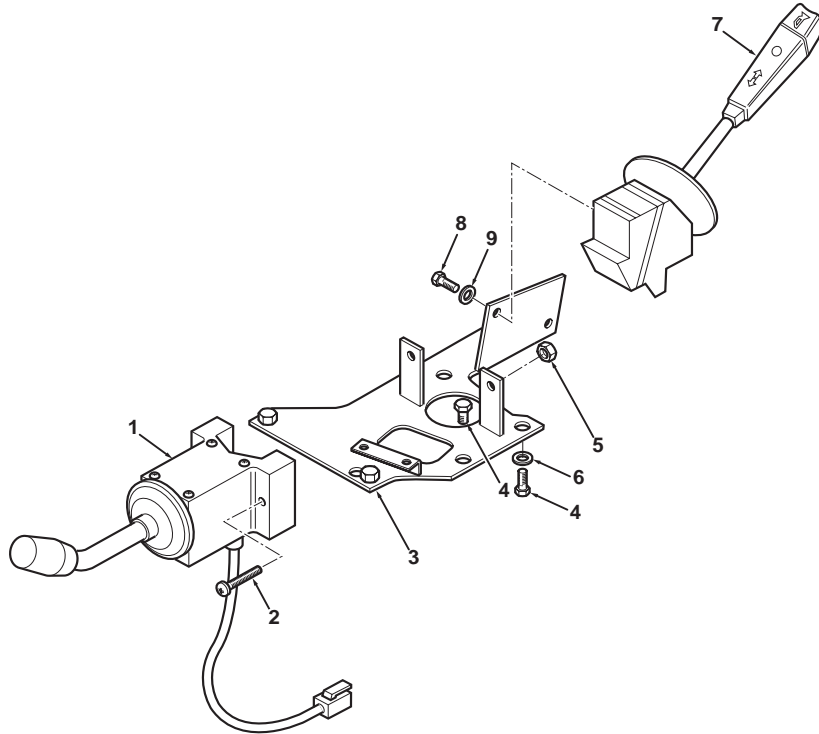

820
 TX760B TX860B
 TX870B

802 806 810 812

55001C04.1

6199042M3

1

Jan-06

Front Console
 Console Avant
 Consola delantera

Forward/Reverse Switch
 Interrupteur de Marche Avant/Arrière
 Interruptor de marcha adelante / atrás

Cab
 Cabine
 Cabina

C-55002-04.1-A

1	3519823M91		1	Switch, Selector	Commutateur	Conmutador
2	3009538X1	M5 x 35	2	Screw	Vis	Tornillo
3	6107120M91		1	Bracket Assy	Ensemble chaise palier	Cuchara, Conj.
4	339124X1	M8 x 16	6	Screw	Vis	Tornillo
5	1441494X1		2	Nut, Lock	Écrou de blocage	Tuerca de retención
6	390972X1	M8	3	Washer	Rondelle	Arandela
7	3516095M1		1	Switch, Selector	Commutateur	Conmutador
8	3007932X1	M5 x 12	1	Screw	Vis	Tornillo
9	3019560X1		2	Washer	Rondelle	Arandela

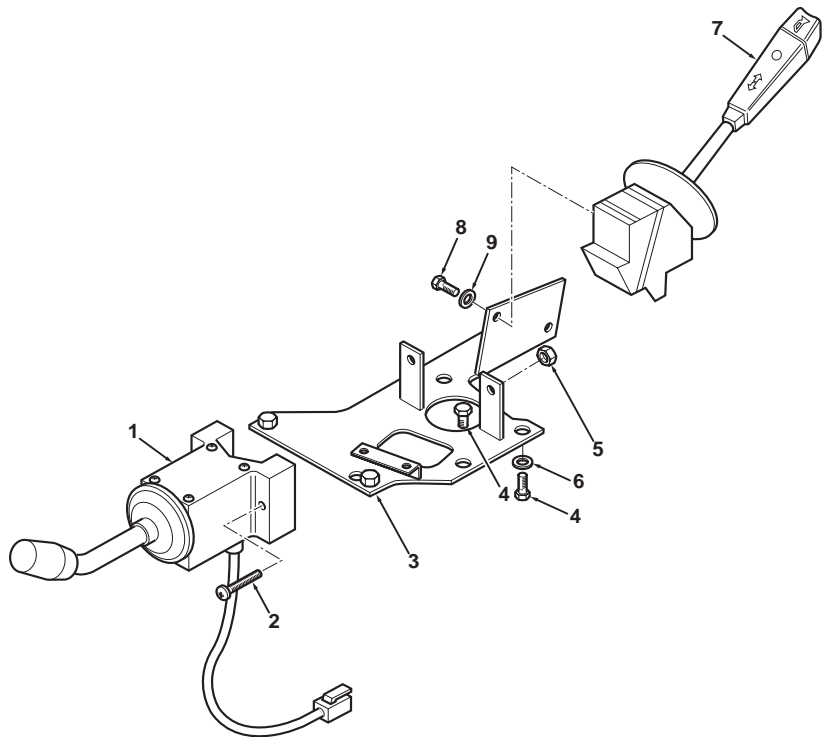

820 860
 TX760B TX860B
 TX870B

801 803 805 809 811 813 815

55002C04.1

6199042M3

1

Jan-06

Front Console
 Console Avant
 Consola delantera

Forward/Reverse Switch
 Interrupteur de Marche Avant/Arrière
 Interruptor de marcha adelante / atrás

Rops
 Rops
 Rops

C-55003-04.1-A

1	3519823M91	55003C01.1 2	1	Switch, Selector	Commutateur	Conmutador
2	3009538X1	M5 x 35	2	Screw	Vis	Tornillo
3	6107120M91		1	Bracket Assy	Ensemble chaise palier	Cuchara, Conj.
4	339124X1	M8 x 16	6	Screw	Vis	Tornillo
5	1441494X1		2	Nut, Lock	Écrou de blocage	Tuerca de retención
6	390972X1	M8	3	Washer	Rondelle	Arandela
7	3516095M1		1	Switch, Selector	Commutateur	Conmutador
8	3007932X1	M5 x 12	1	Screw	Vis	Tornillo
9	3019560X1		2	Washer	Rondelle	Arandela

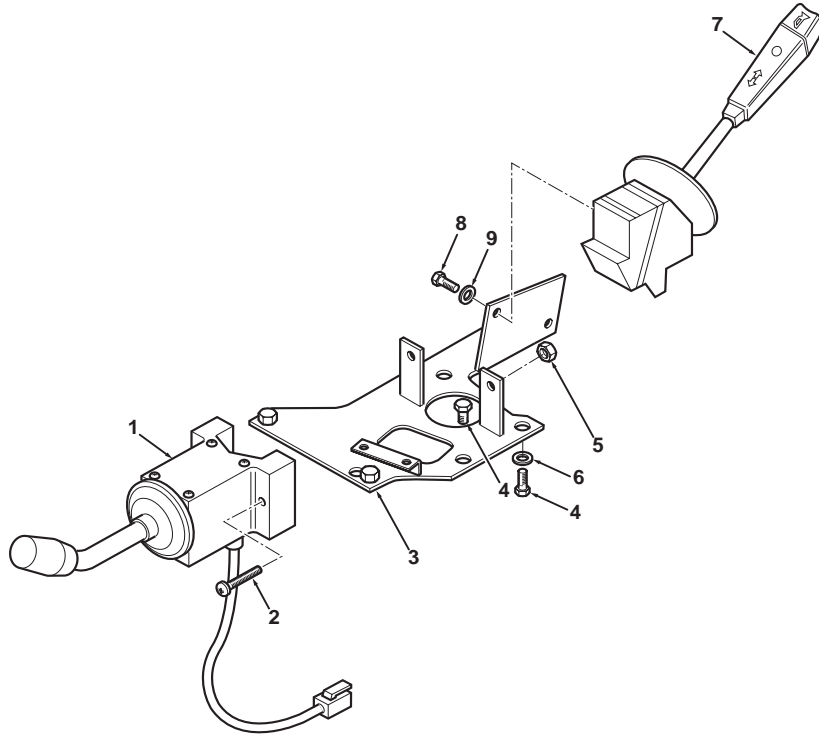

820 860 880
 TX760B TX860B
 TX870B

804 808 814 816 832 834 842 844

55003C04.1

6199042M3

1

Jan-06

Front Console
 Console Avant
 Consola delantera

Forward/Reverse Switch
 Interrupteur de Marche Avant/Arrière
 Interruptor de marcha adelante / atrás

Rops
 Rops
 Rops

C-55004-04.1-A

1	3519823M91	55004C01.1 2	1	Switch, Selector	Commutateur	Conmutador
2	3009538X1	M5 x 35	2	Screw	Vis	Tornillo
3	6107120M91		1	Bracket Assy	Ensemble chaise palier	Cuchara, Conj.
4	339124X1	M8 x 16	6	Screw	Vis	Tornillo
5	1441494X1		2	Nut, Lock	Écrou de blocage	Tuerca de retención
6	390972X1	M8	3	Washer	Rondelle	Arandela
7	3516095M1		1	Switch, Selector	Commutateur	Conmutador
8	3007932X1	M5 x 12	1	Screw	Vis	Tornillo
9	3019560X1		2	Washer	Rondelle	Arandela

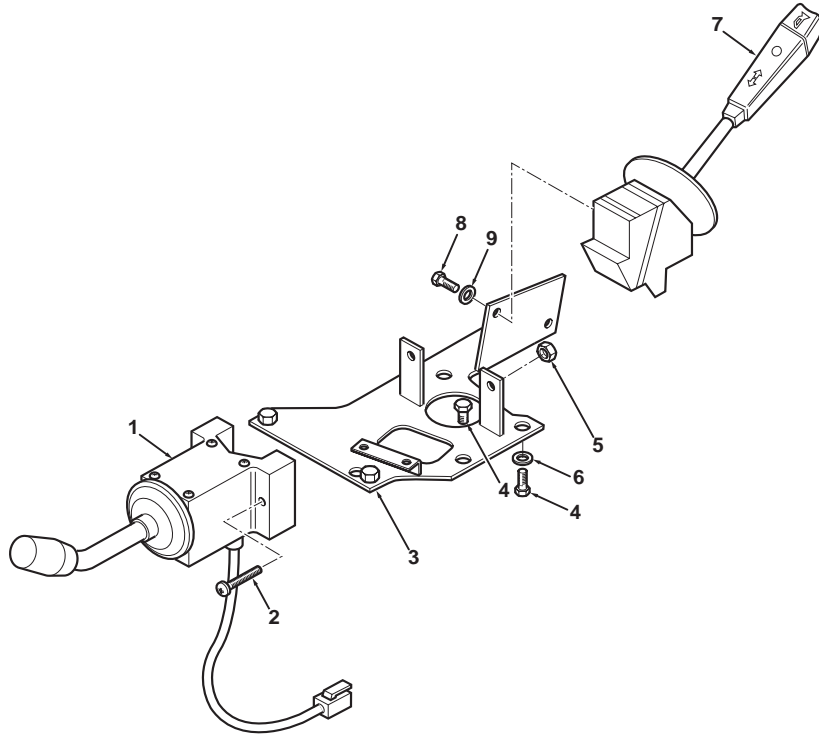

820 860 880
 TX760B TX860B
 TX870B

804 808 814 816 832 834 842 844

55004C04.1

6199042M3

1

Jan-06

Front Console
 Console Avant
 Consola delantera

Forward/Reverse Switch
 Interrupteur de Marche Avant/Arrière
 Interruptor de marcha adelante / atrás

Cab
 Cabine
 Cabina

C-55005-04.1-A

1	3519823M91	55005C01.1 2	1	Switch, Selector	Commutateur	Conmutador
2	3009538X1	M5 x 35	2	Screw	Vis	Tornillo
3	6107120M91		1	Bracket Assy	Ensemble chaise palier	Cuchara, Conj.
4	339124X1	M8 x 16	6	Screw	Vis	Tornillo
5	1441494X1		2	Nut, Lock	Écrou de blocage	Tuerca de retención
6	390972X1	M8	3	Washer	Rondelle	Arandela
7	3516095M1		1	Switch, Selector	Commutateur	Conmutador
8	3007932X1	M5 x 12	1	Screw	Vis	Tornillo
9	3019560X1		2	Washer	Rondelle	Arandela

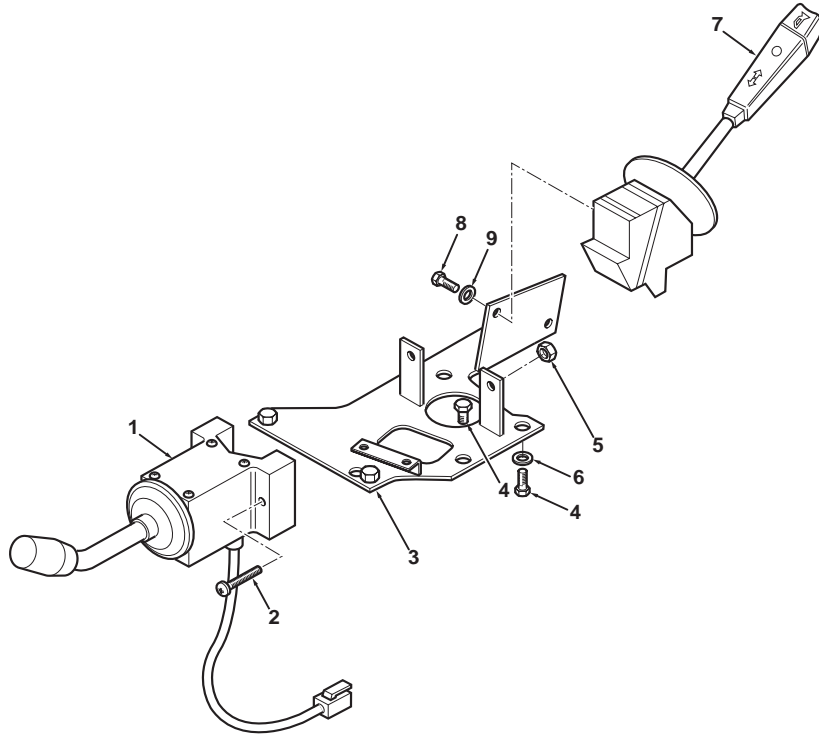

820 860 880
 TX760B TX860B
 TX870B

803 807 813 815 817 831 833 841 843 845

55005C04.1

6199042M3

1

Jan-06

Front Console
 Console Avant
 Consola delantera

Forward/Reverse Switch
 Interrupteur de Marche Avant/Arrière
 Interruptor de marcha adelante / atrás

Cab
 Cabine
 Cabina

C-55006-04.1-A

1	3519823M91	55006C01.1 2	1	Switch, Selector	Commutateur	Conmutador
2	3009538X1	M5 x 35	2	Screw	Vis	Tornillo
3	6107120M91		1	Bracket Assy	Ensemble chaise palier	Cuchara, Conj.
4	339124X1	M8 x 16	6	Screw	Vis	Tornillo
5	1441494X1		2	Nut, Lock	Écrou de blocage	Tuerca de retención
6	390972X1	M8	3	Washer	Rondelle	Arandela
7	3516095M1		1	Switch, Selector	Commutateur	Conmutador
8	3007932X1	M5 x 12	1	Screw	Vis	Tornillo
9	3019560X1		2	Washer	Rondelle	Arandela

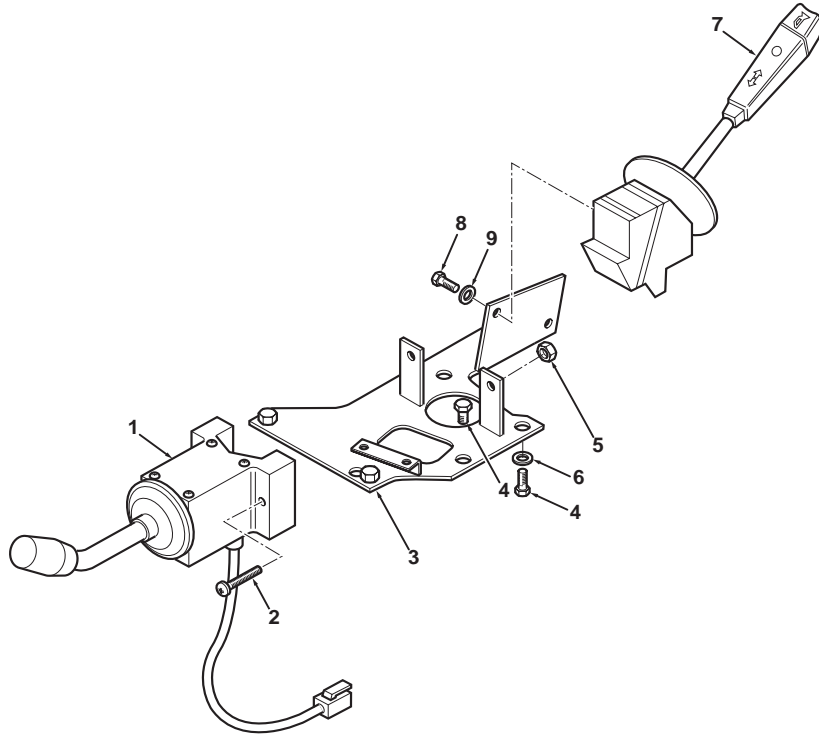

820 860 880
 TX760B TX860B
 TX870B

803 807 813 815 817 831 833 841 843 845 851

55006C04.1

6199042M3

1

Jan-06

Front Console
 Console Avant
 Consola delantera

Forward/Reverse Switch
 Interrupteur de Marche Avant/Arrière
 Interruptor de marcha adelante / atrás

Cab
 Cabine
 Cabina

C-55009-04.1-A

1	6106398M91	55009C01.1 2	1	Switch, Selector	Commutateur	Conmutador
2	3009538X1	M5 x 35	2	Screw	Vis	Tornillo
3	6107120M91		1	Bracket Assy	Ensemble chaise palier	Cuchara, Conj.
4	339124X1	M8 x 16	6	Screw	Vis	Tornillo
5	1441494X1		2	Nut, Lock	Écrou de blocage	Tuerca de retención
6	390972X1	M8	3	Washer	Rondelle	Arandela
7	3516095M1		1	Switch, Selector	Commutateur	Conmutador
8	3007932X1	M5 x 12	1	Screw	Vis	Tornillo
9	3019560X1		2	Washer	Rondelle	Arandela

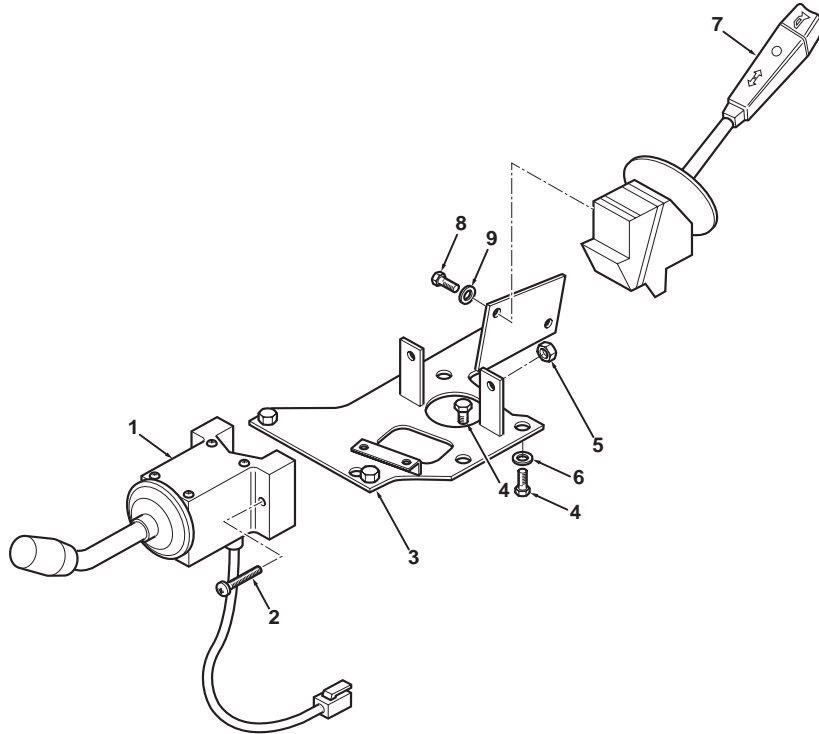

860 880 970 980
 TX860B TX870B
 TX970B

821 823 825 841 843 845 851 853 855 921 922 923 931 932

55009C04.1

6199042M3

1

Jan-06

Front Console
 Console Avant
 Consola delantera

Forward/Reverse Switch
 Interrupteur de Marche Avant/Arrière
 Interruptor de marcha adelante / atrás

Cab
 Cabine
 Cabina

C-55010-04.1-A

1	6106398M91	55010C01.1 2	1	Switch, Selector	Commutateur	Conmutador
2	3009538X1	M5 x 35	2	Screw	Vis	Tornillo
3	6107120M91		1	Bracket Assy	Ensemble chaise palier	Cuchara, Conj.
4	339124X1	M8 x 16	6	Screw	Vis	Tornillo
5	1441494X1		2	Nut, Lock	Écrou de blocage	Tuerca de retención
6	390972X1	M8	3	Washer	Rondelle	Arandela
7	3516095M1		1	Switch, Selector	Commutateur	Conmutador
8	3007932X1	M5 x 12	1	Screw	Vis	Tornillo
9	3019560X1		2	Washer	Rondelle	Arandela

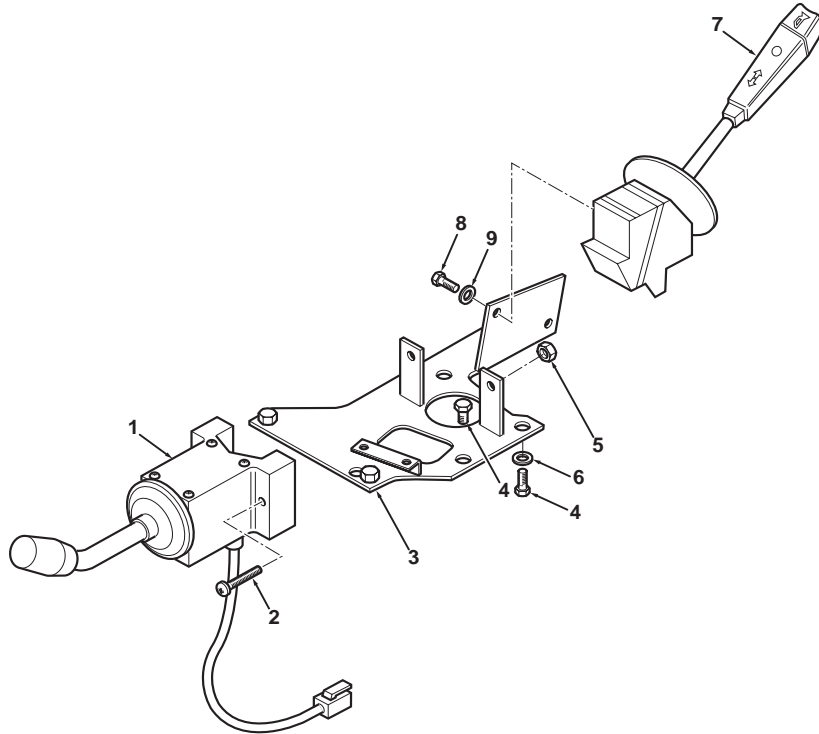

860 880 970 980
 TX860B TX870B
 TX970B

821 823 825 851 853 855 921 922 923 931 932

55010C04.1

6199042M3

1

Jan-06

Front Console
Console Avant
Consola delantera

Instrument Panel
Tableau de Bord
Tablero de instrumentos

Rops
Rops
Rops

C-55001-03.1-A

1	6099537M1	55001C01.1 4	1	Panel, Instrument	Tableau de bord	Tablero instrumentos
2	6102305M93		1	Panel, Instrument	Tableau de bord	Tablero instrumentos
3	6101807M1		1	Cover Sheet	Couvercle	Tapa
4	3019002X1	M4 x 25	7	Screw	Vis	Tornillo
5	6101590M1	M4	7	Nut, U	Écrou en U	Tuerca en U
6	6109915M1		1	Panel	Panneau	Panel
7	6109902M1		1	Panel	Panneau	Panel
8	3516218M2		4	Screw	Vis	Tornillo
9	6109915M1		1	Panel	Panneau	Panel
10	3516218M2		4	Screw	Vis	Tornillo

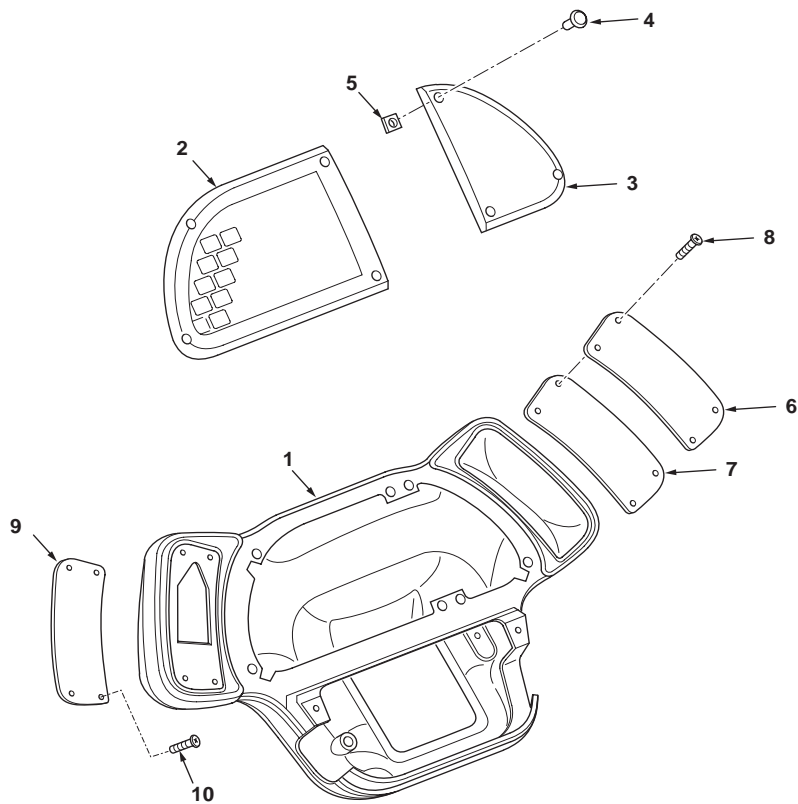

820
TX760B TX860B
TX870B

802 806 810 812

55001C03.1

6199042M3

1

Jan-06

Front Console
 Console Avant
 Consola delantera

Instrument Panel
 Tableau de Bord
 Tablero de instrumentos

Cab
 Cabine
 Cabina

C-55002-03.1-A

1	6099537M1		55002C01.1 4	1	Panel, Instrument	Tableau de bord	Tablero instrumentos
2	6109507M91			1	Switchpack	Paquet de commut.	Paquete de cambio
3		2	Ref. 2	1	Switchpack	Paquet de commut.	Paquete de cambio
4	6101778M1	2		2	Cover	Cache	Tapa
5	6101777M91	2	Switch	3	Cover	Cache	Tapa
6	6102305M93			1	Panel, Instrument	Tableau de bord	Tablero instrumentos
7	6101807M1			1	Cover Sheet	Couvercle	Tapa
8	365919X1			7	Screw	Vis	Tornillo
9	6101590M1		M4	7	Nut, U	Écrou en U	Tuerca en U
10	6109915M1			1	Panel	Panneau	Panel
11	3516218M2			4	Screw	Vis	Tornillo

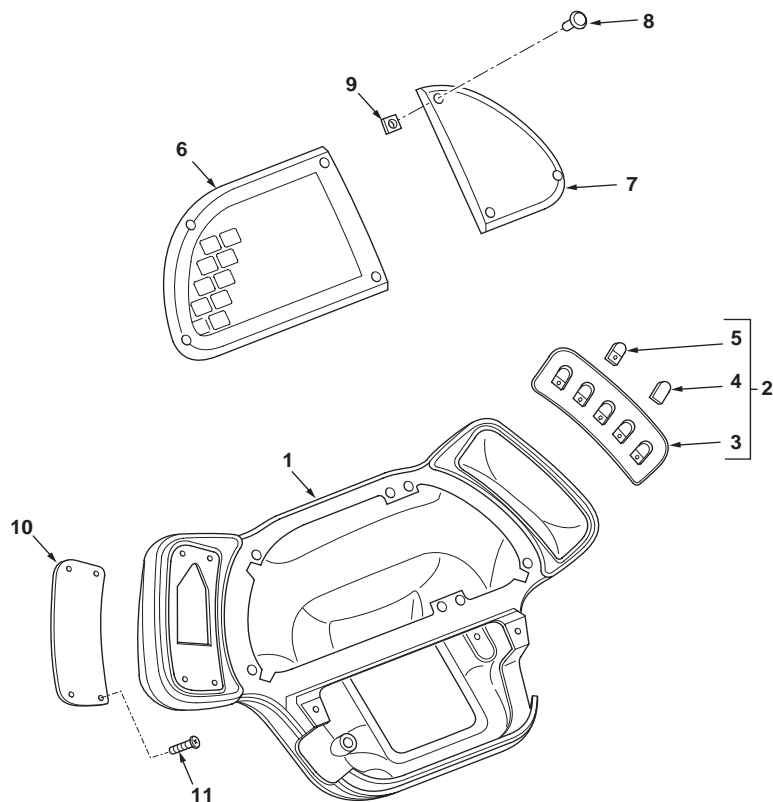

820 860
 TX760B TX860B
 TX870B

801 803 805 809 811 813 815

55002C03.1

6199042M3

1

Jan-06

Front Console
Console Avant
Consola delantera

Instrument Panel
Tableau de Bord
Tablero de instrumentos

Rops
Rops
Rops

C-55003-03.1-A

1	6099537M1	55003C01.1 4	1	Panel, Instrument	Tableau de bord	Tablero instrumentos
2	6109902M1		1	Panel	Panneau	Panel
3	6109915M1		1	Panel	Panneau	Panel
4	3516218M2		4	Screw	Vis	Tornillo
5	6102305M93		1	Panel, Instrument	Tableau de bord	Tablero instrumentos
6	6101807M1		1	Cover Sheet	Couvercle	Tapa
7	3019002X1	M4 x 25	7	Screw	Vis	Tornillo
8	6101590M1	M4	7	Nut, U	Écrou en U	Tuerca en U
9	3519935M91		1	Switch	Contacteur	Contactar
10	6106194M1		1	Plate	Plaque	Placa
11	6106195M2		1	Plate	Plaque	Placa
12	3009542X1	M6 x 45	1	Screw	Vis	Tornillo
13	3516528M1		1	Spacer	Entretoise	Traviesa
14	3516528M1		2	Spacer	Entretoise	Traviesa
15	390971X1	M6	1	Washer	Rondelle	Arandela
16	3516529M1		1	Spring	Ressort	Muelle
17	1441500X1	M6	4	Nut, Lock	Écrou de blocage	Tuerca de retención
18	3516218M2		1	Screw	Vis	Tornillo
19	6106221M1		4	Decal	Adhésif	Adhesivo

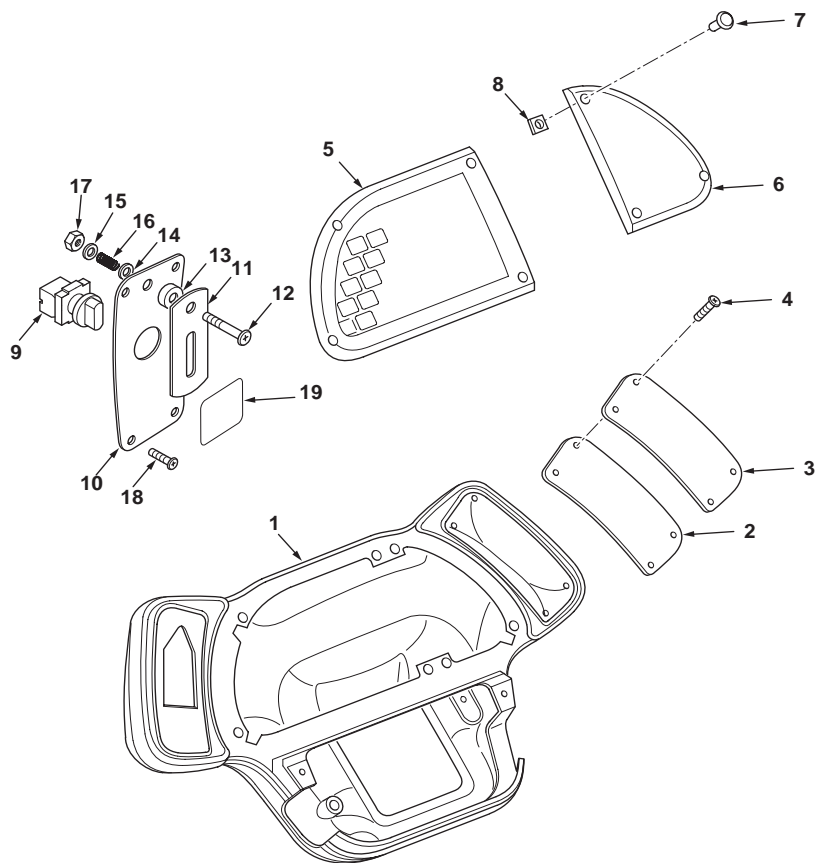

820 860 880
TX760B TX860B
TX870B

804 808 814 816 832 834 842 844

55003C03.1

6199042M3

1

Jan-06

Front Console
Console Avant
Consola delantera

Instrument Panel
Tableau de Bord
Tablero de instrumentos

Rops
Rops
Rops

C-55004-03.1-A

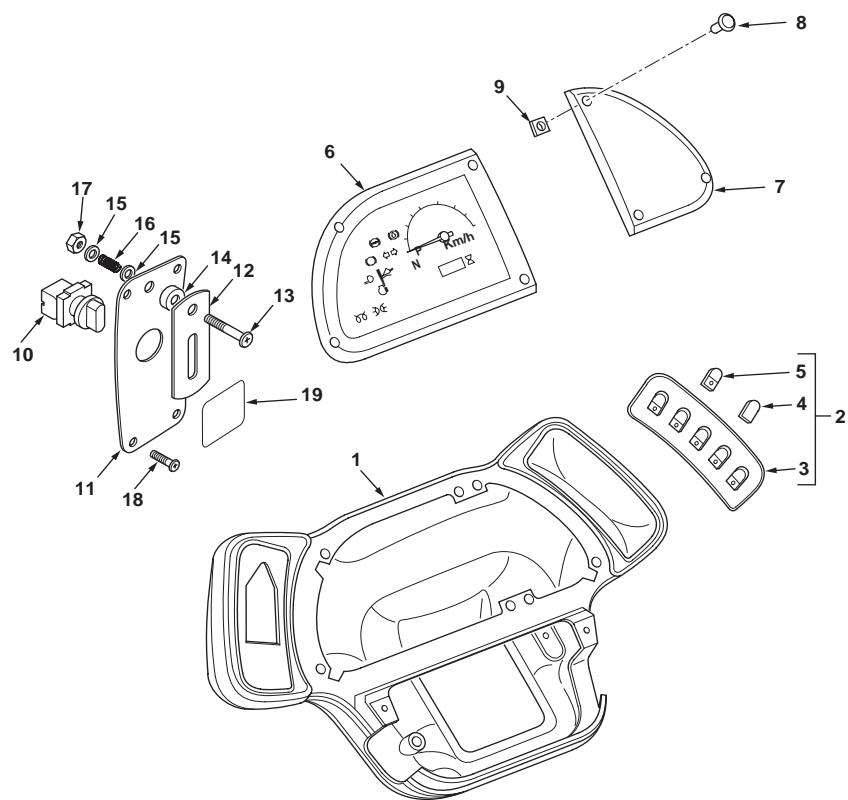

1	6099537M1	55004C01.1 4	1	Panel, Instrument	Tableau de bord	Tablero instrumentos
2	6109507M91		1	Switchpack	Paquet de commut.	Paquete de cambio
3		Ref. 2	1	Switchpack	Paquet de commut.	Paquete de cambio
4	6101778M1		2	Cover	Cache	Tapa
5	6101777M91	Switch	3	Cover	Cache	Tapa
6	6102305M93		1	Panel, Instrument	Tableau de bord	Tablero instrumentos
7	6101807M1		1	Cover Sheet	Couvercle	Tapa
8	3019002X1	M4 x 25	7	Screw	Vis	Tornillo
9	6101590M1	M4	7	Nut, U	Écrou en U	Tuerca en U
10	3519935M91		1	Switch	Contacteur	Contactar
11	6106194M1		1	Plate	Plaque	Placa
12	6106195M2		1	Plate	Plaque	Placa
13	3009542X1	M6 x 45	1	Screw	Vis	Tornillo
14	3516528M1		1	Spacer	Entretoise	Traviesa
15	390971X1	M6	2	Washer	Rondelle	Arandela
16	3516529M1		1	Spring	Ressort	Muelle
17	1441500X1	M6	1	Nut, Lock	Écrou de blocage	Tuerca de retención
18	3516218M2		4	Screw	Vis	Tornillo
19	6106221M1		1	Decal	Adhésif	Adhesivo



820 860 880
TX760B TX860B
TX870B

804 808 814 816 832 834 842 844

55004C03.1

6199042M3

1

Jan-06

Front Console
Console Avant
Consola delantera

Instrument Panel
Tableau de Bord
Tablero de instrumentos

Cab
Cabine
Cabina

C-55005-03.1-A

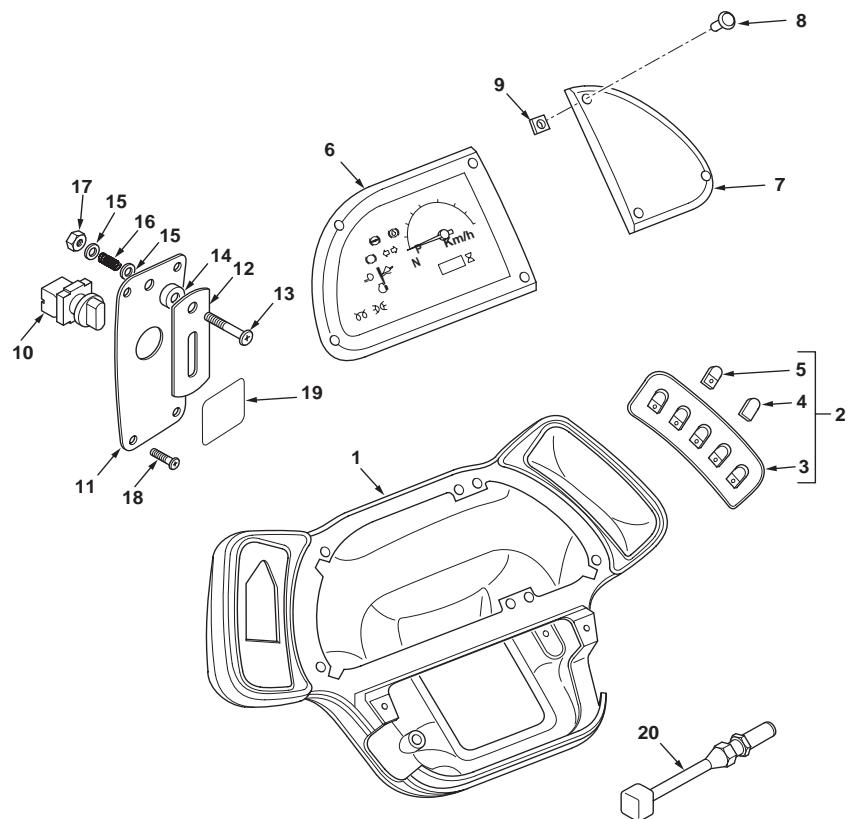

1	6099537M1	55005C01.1 4	1	Panel, Instrument	Tableau de bord	Tablero instrumentos
2	6109507M91		1	Switchpack	Paquet de commut.	Paquete de cambio
3		Ref. 2	1	Switchpack	Paquet de commut.	Paquete de cambio
4	6101778M1		2	Cover	Cache	Tapa
5	6101777M91	Switch	3	Cover	Cache	Tapa
6	6102201M93		1	Panel, Instrument	Tableau de bord	Tablero instrumentos
7	6101807M1		1	Cover Sheet	Couvercle	Tapa
8	365919X1		7	Screw	Vis	Tornillo
9	6101590M1	M4	7	Nut, U	Écrou en U	Tuerca en U
10	3519935M91		1	Switch	Contacteur	Contactar
11	6106194M1		1	Plate	Plaque	Placa
12	6106195M2		1	Plate	Plaque	Placa
13	3009542X1	M6 x 45	1	Screw	Vis	Tornillo
14	3516528M1		1	Spacer	Entretoise	Traviesa
15	390971X1	M6	2	Washer	Rondelle	Arandela
16	3516529M1		1	Spring	Ressort	Muelle
17	1441500X1	M6	1	Nut, Lock	Écrou de blocage	Tuerca de retención
18	3516218M2		4	Screw	Vis	Tornillo
19	6106221M1		1	Decal	Adhésif	Adhesivo
20	3518561M91		1	Sensor	Capteur	Captador



820 860 880
TX760B TX860B
TX870B

803 807 813 815 817 831 833 841 843 845

55005C03.1

6199042M3

1

Jan-06

Front Console
Console Avant
Consola delantera

Instrument Panel
Tableau de Bord
Tablero de instrumentos

Cab
Cabine
Cabina

C-55006-03.1-A

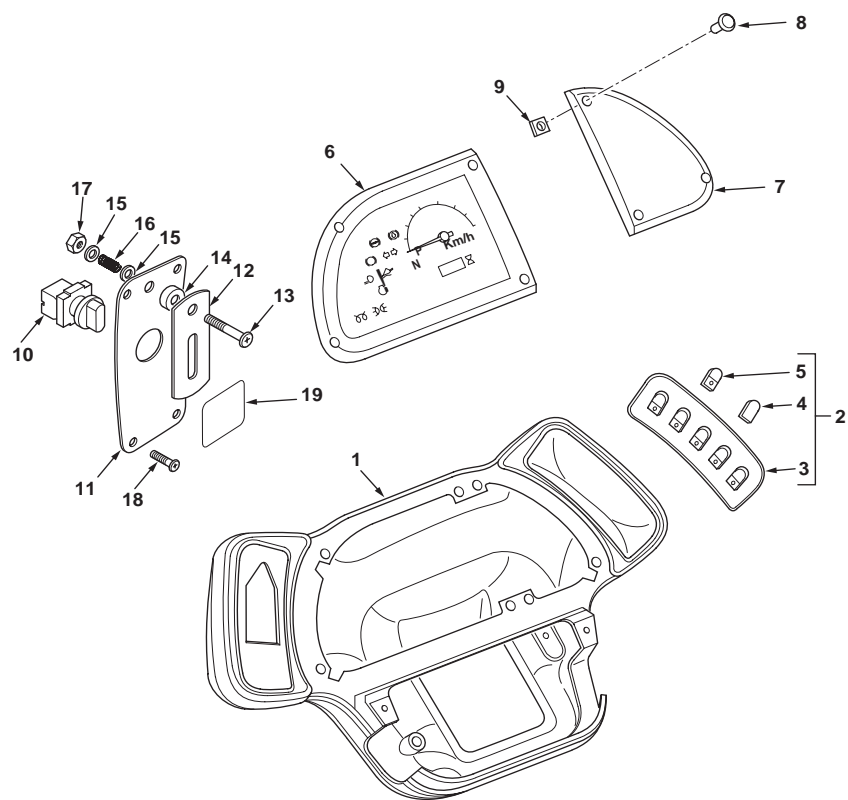

1	6099537M1	55006C01.1 4	1	Panel, Instrument	Tableau de bord	Tablero instrumentos
2	6109507M91		1	Switchpack	Paquet de commut.	Paquete de cambio
3		Ref. 2	1	Switchpack	Paquet de commut.	Paquete de cambio
4	6101778M1		2	Cover	Cache	Tapa
5	6101777M91	Switch	3	Cover	Cache	Tapa
6	6102305M93		1	Panel, Instrument	Tableau de bord	Tablero instrumentos
7	6101807M1		1	Cover Sheet	Couvercle	Tapa
8	365919X1		7	Screw	Vis	Tornillo
9	6101590M1	M4	7	Nut, U	Écrou en U	Tuerca en U
10	3519935M91		1	Switch	Contacteur	Contactar
11	6106194M1		1	Plate	Plaque	Placa
12	6106195M2		1	Plate	Plaque	Placa
13	3009542X1	M6 x 45	1	Screw	Vis	Tornillo
14	3516528M1		1	Spacer	Entretoise	Traviesa
15	390971X1	M6	2	Washer	Rondelle	Arandela
16	3516529M1		1	Spring	Ressort	Muelle
17	1441500X1	M6	1	Nut, Lock	Écrou de blocage	Tuerca de retención
18	3516218M2		4	Screw	Vis	Tornillo
19	6106221M1		1	Decal	Adhésif	Adhesivo



820 860 880
TX760B TX860B
TX870B

803 807 813 815 817 831 833 841 843 845 851

55006C03.1

6199042M3

1

Jan-06

Front Console
Console Avant
Consola delantera

Instrument Panel
Tableau de Bord
Tablero de instrumentos

Cab
Cabine
Cabina

C-55009-03.1-A

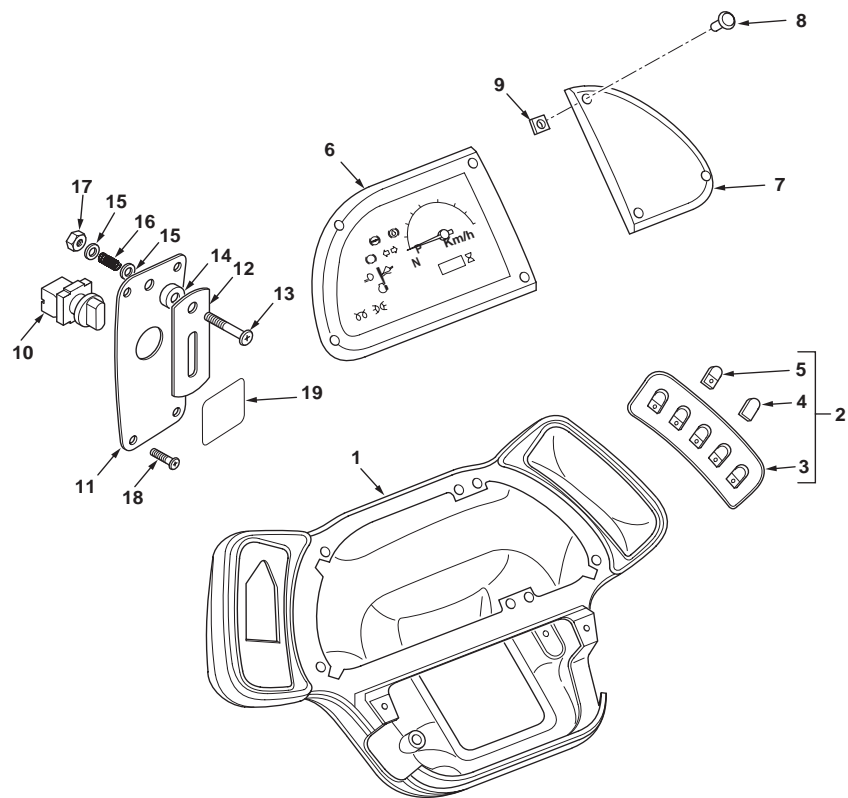

1	6099537M1	55009C01.1 4	1	Panel, Instrument	Tableau de bord	Tablero instrumentos
2	6109507M91		1	Switchpack	Paquet de commut.	Paquete de cambio
3		Ref. 2	1	Switchpack	Paquet de commut.	Paquete de cambio
4	6101778M1		2	Cover	Cache	Tapa
5	6101777M91	Switch	3	Cover	Cache	Tapa
6	6102201M93		1	Panel, Instrument	Tableau de bord	Tablero instrumentos
7	6101807M1		1	Cover Sheet	Couvercle	Tapa
8	365919X1		7	Screw	Vis	Tornillo
9	6101590M1	M4	7	Nut, U	Écrou en U	Tuerca en U
10	3519935M91		1	Switch	Contacteur	Contactar
11	6106194M1		1	Plate	Plaque	Placa
12	6106195M2		1	Plate	Plaque	Placa
13	3009542X1	M6 x 45	1	Screw	Vis	Tornillo
14	3516528M1		1	Spacer	Entretoise	Traviesa
15	390971X1	M6	2	Washer	Rondelle	Arandela
16	3516529M1		1	Spring	Ressort	Muelle
17	1441500X1	M6	1	Nut, Lock	Écrou de blocage	Tuerca de retención
18	3516218M2		4	Screw	Vis	Tornillo
19	6106221M1		1	Decal	Adhésif	Adhesivo



860 880 970 980
TX860B TX870B
TX970B

821 823 825 841 843 845 851 853 855 921 922 923 931 932

55009C03.1

6199042M3

1

Jan-06

Front Console
Console Avant
Consola delantera

Instrument Panel
Tableau de Bord
Tablero de instrumentos

Cab
Cabine
Cabina

C-55010-03.1-A

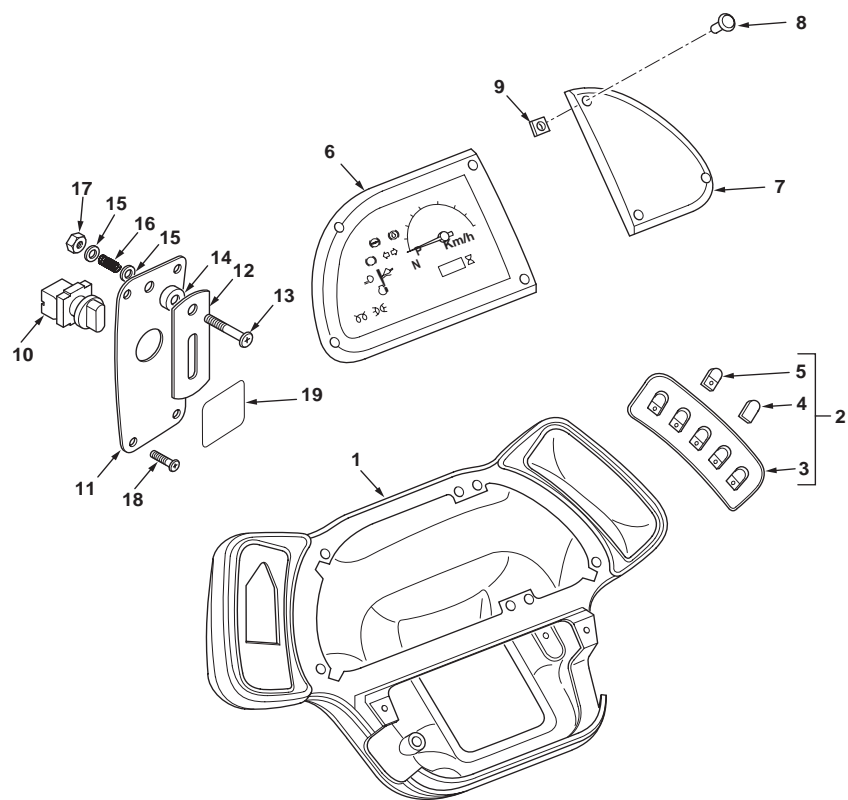

1	6099537M1	55010C01.1 4	1	Panel, Instrument	Tableau de bord	Tablero instrumentos
2	6109507M91		1	Switchpack	Paquet de commut.	Paquete de cambio
3		Ref. 2	1	Switchpack	Paquet de commut.	Paquete de cambio
4	6101778M1		2	Cover	Cache	Tapa
5	6101777M91	Switch	3	Cover	Cache	Tapa
6	6102305M93		1	Panel, Instrument	Tableau de bord	Tablero instrumentos
7	6101807M1		1	Cover Sheet	Couvercle	Tapa
8	365919X1		7	Screw	Vis	Tornillo
9	6101590M1	M4	7	Nut, U	Écrou en U	Tuerca en U
10	3519935M91		1	Switch	Contacteur	Contactar
11	6106194M1		1	Plate	Plaque	Placa
12	6106195M2		1	Plate	Plaque	Placa
13	3009542X1	M6 x 45	1	Screw	Vis	Tornillo
14	3516528M1		1	Spacer	Entretoise	Traviesa
15	390971X1	M6	2	Washer	Rondelle	Arandela
16	3516529M1		1	Spring	Ressort	Muelle
17	1441500X1	M6	1	Nut, Lock	Écrou de blocage	Tuerca de retención
18	3516218M2		4	Screw	Vis	Tornillo
19	6106221M1		1	Decal	Adhésif	Adhesivo



860 880 970 980
TX860B TX870B
TX970B

821 823 825 851 853 855 921 922 923 931 932

55010C03.1

6199042M3

1

Jan-06

Mirrors
Rétroviseurs
Retrovisores

Cab
Cabine
Cabina

AC-61001-01.1-A

1	ACC31A			1	Accessory code	Code accessoire	Código accesorio
2	3512336M91	1		2	Mirror, Rear View	Rétroviseur	Espejo retrovisor
3		2	 Ref. 2	1	Body	Corps	Cuerpo
4	3477528M1	2		1	Glass	Vitre	Cristal
5	6108734M91	1		2	Arm Assy	Ensemble de bras	Brazo, Conj.
6	3512463M1	1	M6 x 16	8	Screw	Vis	Tornillo
7	3512395M1	1	M6	8	Washer	Rondelle	Arandela

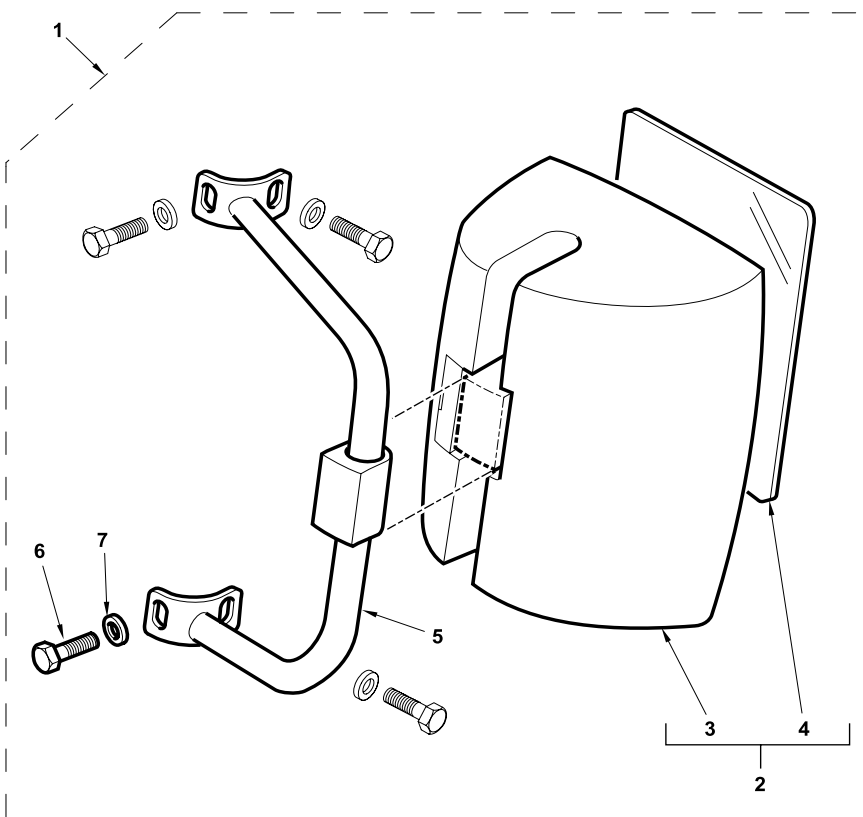

820 860 880 970 980
TX760B TX860B
TX870B TX970B

801 802 803 804 805 806 807 808 809 810 811 812 813 814 815 816 817 821 822
823 824 825 831 832 833 841 842 843 844 845 851 852 853 855 921 922 923 931
932

61001AC01.1

6199042M3

1

Jan-06

Mirrors
Rétroviseurs
Retrovisores

Cab
Cabine
Cabina

C-61001-01.1-A

1	3512336M91			2	Mirror, Rear View	Rétroviseur	Espejo retrovisor
2		1	➡ Ref. 1	1	Body	Corps	Cuerpo
3	3477528M1	1		1	Glass	Vitre	Cristal
4	6108734M91			2	Arm Assy	Ensemble de bras	Brazo, Conj.
5	3512463M1	M6 x 16		8	Screw	Vis	Tornillo
6	3512395M1	M6		8	Washer	Rondelle	Arandela

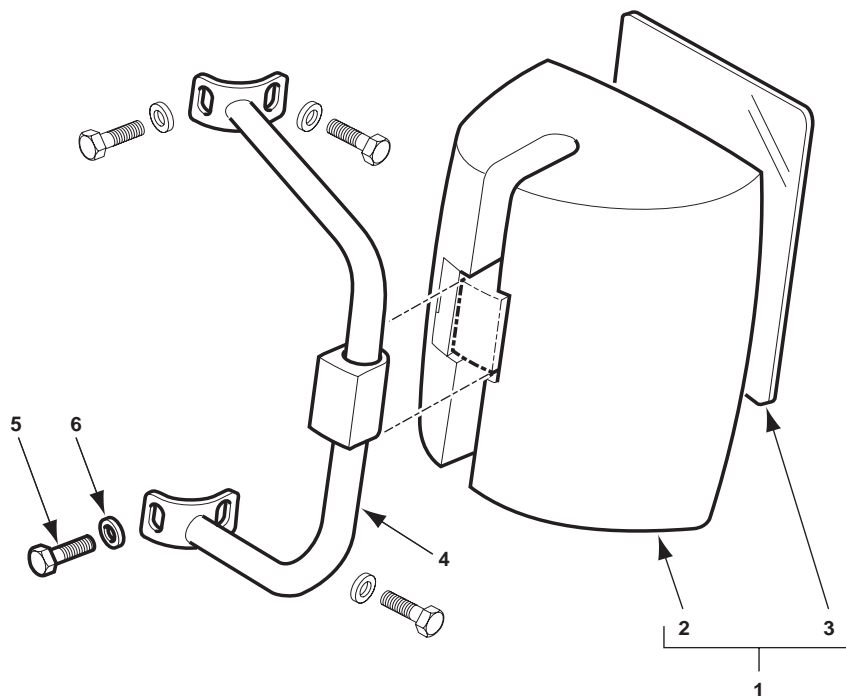

820 860 880 970 980
TX760B TX860B
TX870B TX970B

801 802 803 804 805 806 807 808 809 810 811 812 813 814 815 816 817 821 822
823 824 825 831 832 833 841 842 843 844 845 851 852 853 855 921 922 923 931
932

61001C01.1

6199042M3

1

Jan-06

Mirrors
Rétroviseurs
Retrovisores

ROPS
ROPS
ROPS

4 Post ROPS
4 Poteau ROPS
4 poste ROPS

C-61002-01.1-A

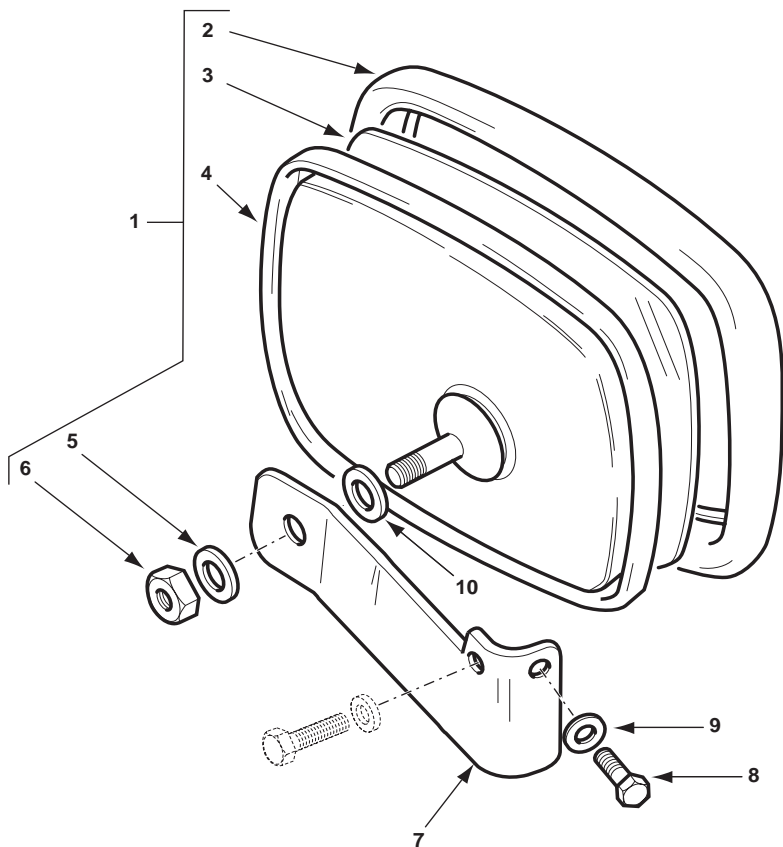

1	1473839M91			1	Mirror, Rear View	Rétroviseur	Espejo retrovisor
2	3523750M1	1		1	Surround	Ceinture	Envolvente
3	3523749M1	1		1	Glass	Vitre	Cristal
4		1	➡ Ref. 1	1	Body	Corps	Cuerpo
5	391039X1	1	M8	1	Washer	Rondelle	Arandela
6	339169X1	1	M8	1	Nut	Écrou	Tuerca
7	6108798M1			1	Bracket	Patte de fixation	Pata de fijación
8	3512463M1		M6 x 16	2	Screw	Vis	Tornillo
9	3512395M1		M6	2	Washer	Rondelle	Arandela
10	6107983M1			1	Spacer	Entretoise	Traviesa



820 860 880
TX760B TX860B
TX870B

802 804 806 808 810 812 814 816 822 824 831 832 834 841 843 851

61002C01.1

6199042M3

1

Jan-06

Seat
Siège
Asiento

Fabric Trim
Finition Tissu
Tapizado de tela

Cab
Cabine
Cabina

C-62001-02.1-A

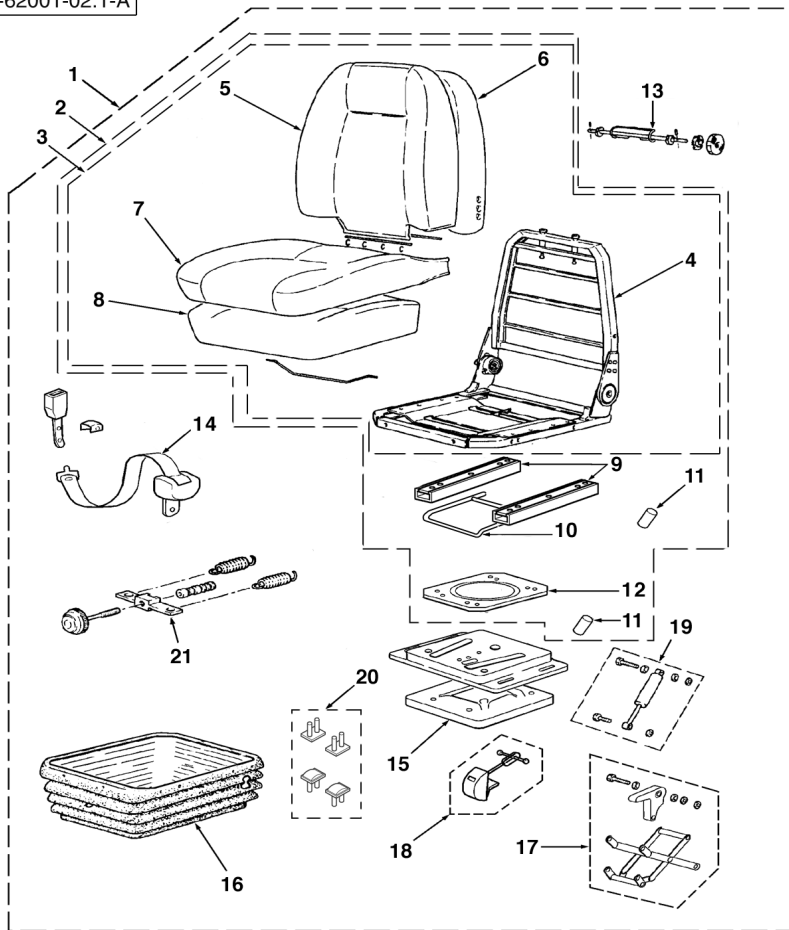

1	6108904M91		62001C01.1 6	1	Seat Assy	Ensemble des sièges	Asiento, Conj.
2	6193722M91	1		1	Seat	Siège	Asiento
3	6193724M91	2		1	Seat	Siège	Asiento
4	6193726M91	3		1	Frame Assy	Ensemble de bâti	Bastidor, Conj.
5	6193727M91	3		1	Cover, Seat	Housse	Cubre asiento
6	6190707M91	3		1	Backrest	Dossier	Respaldo
7	6193728M91	3		1	Cover, Seat	Housse	Cubre asiento
8	6190709M91	3		1	Cushion, Seat	Coussin de siège	Cojín de asiento
9	6193731M91	2		1	Slide	Glissière	Corredera
10	6193732M91	2		1	Handle Assy	Ensemble de poignée	Empuñadura, Conj.
11	6193730M1	2		2	Handle	Poignée	Asa
12	6193733M91	2		1	Frame, Turntable	Bâti tourelle	Bastidor torreta
13	6190711M91	1		1	Kit, Parts	Lot de pièces	Juego de piezas
14	6190710M91	1		1	Belt, Seat	Ceinture de sécurité	Cinturón, Seguridad
15	6190718M91	1		1	Suspension	Suspension	Suspensión
16	6190719M91	1		1	Boot	Soufflet	Fuelle
17	6190720M91	1		1	Kit, Parts	Lot de pièces	Juego de piezas
18	6190721M91	1		1	Handle	Poignée	Asa
19	6190722M91	1		1	Shock Absorber	Amortisseur	Amortiguador
20	6190723M91	1		1	Middlebuster	Buteur	Aporcador
21	6190724M91	1		1	Handle	Poignée	Asa



820 860 880 970 980
TX760B TX860B
TX870B TX970B

801 803 805 807 809 811 813 815 817 821 823 825 831 833 841 843 845 851 853
855 921 922 923 931 932

62001C02.1

6199042M3

1

Jan-06

Seat
Siège
Asiento

Fabric Trim
Finition Tissu
Tapizado de tela

Air Suspension
Suspension pneumatique
Suspensión neumática

C-62002-02.1-A

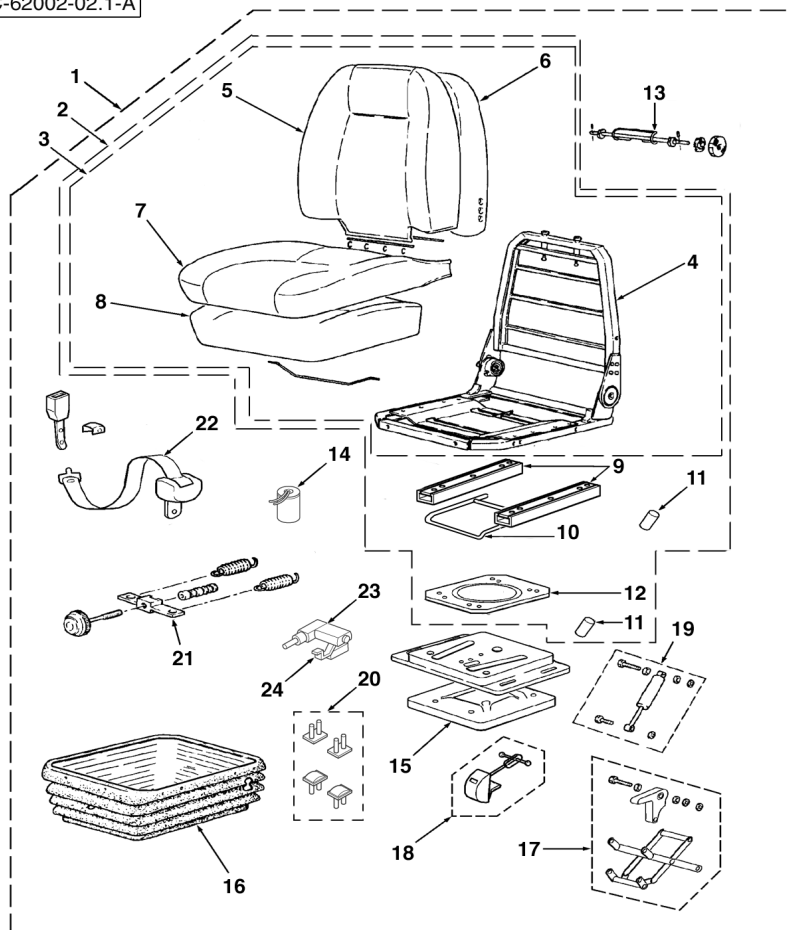

1	6108905M91		62002C01.1 7	1	Seat Assy	Ensemble des sièges	Asiento, Conj.
2	6193722M91	1		1	Seat	Siège	Asiento
3	6193724M91	2		1	Seat	Siège	Asiento
4	6193726M91	3		1	Frame Assy	Ensemble de bâti	Bastidor, Conj.
5	6193727M91	3		1	Cover, Seat	Housse	Cubre asiento
6	6190707M91	3		1	Backrest	Dossier	Respaldo
7	6193728M91	3		1	Cover, Seat	Housse	Cubre asiento
8	6190709M91	3		1	Cushion, Seat	Coussin de siège	Cojín de asiento
9	6193731M91	2		1	Slide	Glissière	Corredera
10	6193732M91	2		1	Handle Assy	Ensemble de poignée	Empuñadura, Conj.
11	6193730M1	2		2	Handle	Poignée	Asa
12	6193733M91	2		1	Frame, Turntable	Bâti tourelle	Bastidor torreta
13	6190711M91	1		1	Kit, Parts	Lot de pièces	Juego de piezas
14	6193738M91	1		1	Kit, Spring	Jeu de ressorts	Juego de muelles
15	6193734M91	1		1	Suspension	Suspension	Suspensión
16	6193735M91	1		1	Boot	Soufflet	Fuelle
17	6193736M91	1		1	Kit, Parts	Lot de pièces	Juego de piezas
18	6190721M91	1		1	Handle	Poignée	Asa
19	6193737M91	1		1	Shock Absorber	Amortisseur	Amortiguador
20	6190723M91	1		1	Middlebuster	Buteur	Aporcador
21	6190724M91	1		1	Handle	Poignée	Asa
22	6190710M91	1		1	Belt, Seat	Ceinture de sécurité	Cinturón, Seguridad
23	6193739M91	1		1	Compressor	Compresseur	Compresor
24	6193740M91	1	"Switch"	1	Kit, Valve	Jeu de soupapes	Juego de válvulas



820 860 880 970 980
TX760B TX860B
TX870B TX970B

801 803 805 807 809 811 813 815 817 821 823 825 831 833 841 843 845 851 853
855 921 922 923 931 932

62002C02.1

6199042M3

1

Jan-06

Seat
Siège
Asiento

Seat Installation
Installation du Siège
Instalación de asiento

Fabric Trim - Cab Machines
Machines Cabine Finition Tissus
Tapizado de tela - tractores con cabina

C-62001-01.1-A

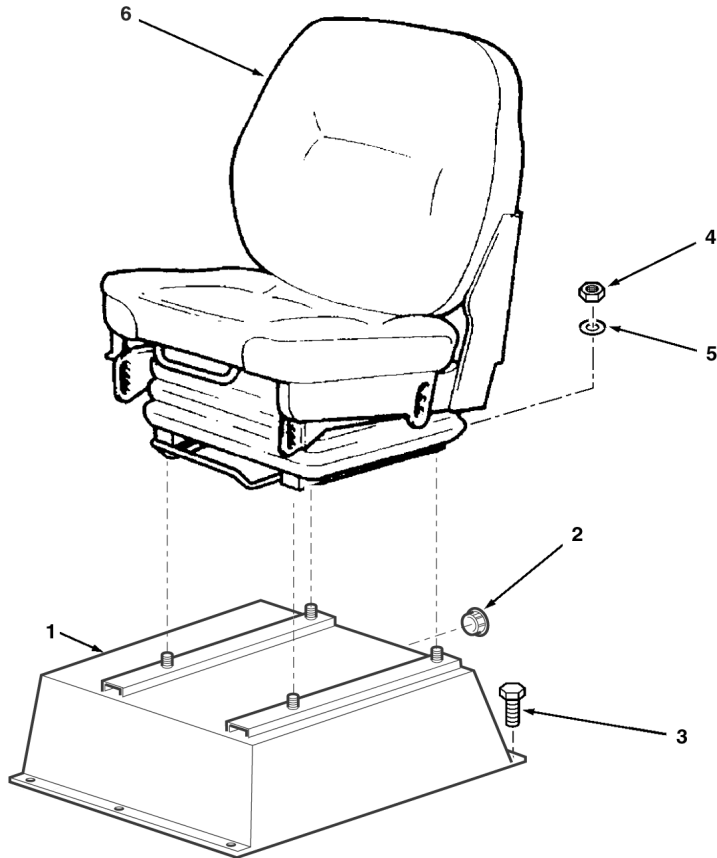

1	6100848M95		1	Pedestal	Socle	Zócalo
2	3517687M1		1	Grommet	Passe-fil	Pasa cable
3	339124X1	M8 x 16	4	Screw	Vis	Tornillo
4	394367X1	M8	4	Nut, Lock	Écrou de blocage	Tuerca de retención
5	390972X1	M8	4	Washer	Rondelle	Arandela
6	6108904M91	62001C02.1 1	1	Seat Assy	Ensemble des sièges	Asiento, Conj.



820 860 880 970 980
TX760B TX860B
TX870B TX970B

801 803 805 807 809 811 813 815 817 821 823 825 831 833 841 843 845 851 853
855 921 922 923 931 932

62001C01.1

6199042M3

1

Jan-06

Seat
Siège
Asiento

Seat Installation
Installation du Siège
Instalación de asiento

Air Suspension
Suspension pneumatique
Suspensión neumática

C-62002-01.1-A

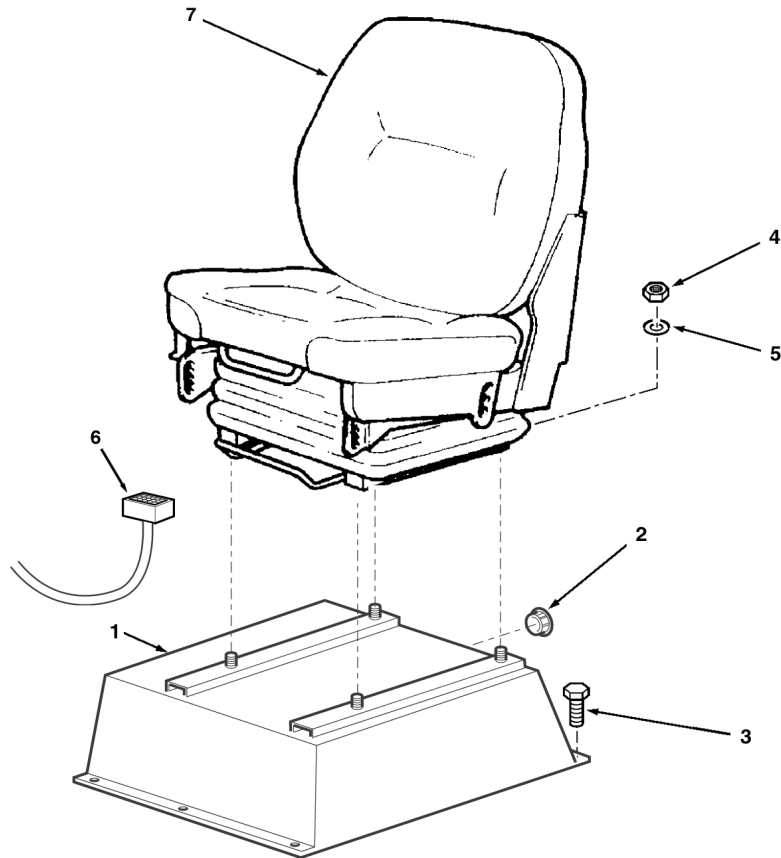

1	6100848M95		1	Pedestal	Socle	Zócalo
2	3517687M1		1	Grommet	Passe-fil	Pasa cable
3	339124X1	M8 x 16	4	Screw	Vis	Tornillo
4	394367X1	M8	4	Nut, Lock	Écrou de blocage	Tuerca de retención
5	390972X1	M8	4	Washer	Rondelle	Arandela
6	6109285M91		1	Harness Assy	Ensemble de faisceau	Haz, Conj.
7	6108905M91	62002C02.1 1	1	Seat Assy	Ensemble des sièges	Asiento, Conj.



820 860 880 970 980
TX760B TX860B
TX870B TX970B

801 803 805 807 809 811 813 815 817 821 823 825 831 833 841 843 845 851 853
855 921 922 923 931 932

62002C01.1

6199042M3

1

Jan-06

Seat
Siège
Asiento

Seat Installation
Installation du Siège
Instalación de asiento

Weatherproof P.V.C. Trim
Finition P.V.C. Étanche
Tapizado de PVC - contra intemperie

Centre mounted digger
Centre mounted digger
Centre mounted digger

C-62003-01.1-A

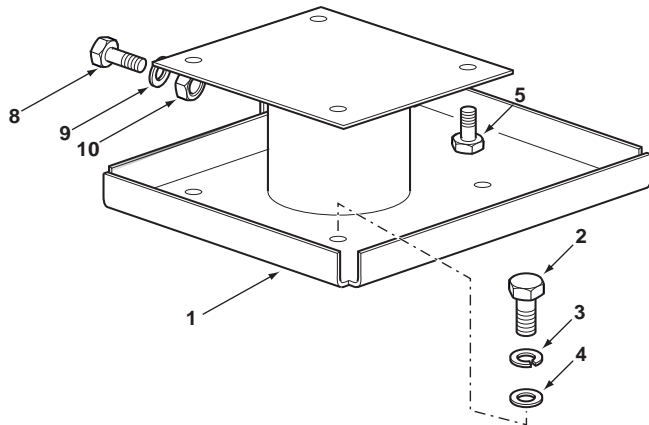
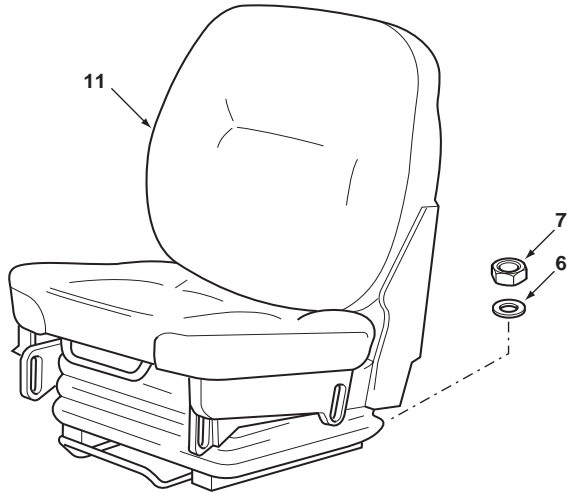

1	6108693M92		1	Pedestal	Socle	Zócalo
2	3009493X1	M10 x 30	4	Bolt	Boulon	Perno
3	339376X1	M10	4	Washer, Lock	Rondelle de blocage	Arandela de freno
4	390734X1	M10	4	Washer	Rondelle	Arandela
5	339761X1	M8 x 25	4	Screw	Vis	Tornillo
6	390972X1	M8	4	Washer	Rondelle	Arandela
7	394367X1	M8	4	Nut, Lock	Écrou de blocage	Tuerca de retención
8	3009493X1	M10 x 30	2	Bolt	Boulon	Perno
9	390734X1	M10	2	Washer	Rondelle	Arandela
10	1440329X1	M10	2	Nut, Lock	Écrou de blocage	Tuerca de retención
11	6108906M91	62003C02.1 1	1	Seat Assy	Ensemble des sièges	Asiento, Conj.



820 860 880
TX760B TX860B
TX870B

802 804 810 812 814 816 822 824 832 842 844 852 854

62003C01.1

6199042M3

1

Jan-06

Seat
Siège
Asiento

Seat Installation
Installation du Siège
Instalación de asiento

Weatherproof P.V.C. Trim
Finition P.V.C. Étanche
Tapizado de PVC - contra intemperie

Sideshift digger
Sideshift digger
Sideshift digger

C-62004-01.1-A

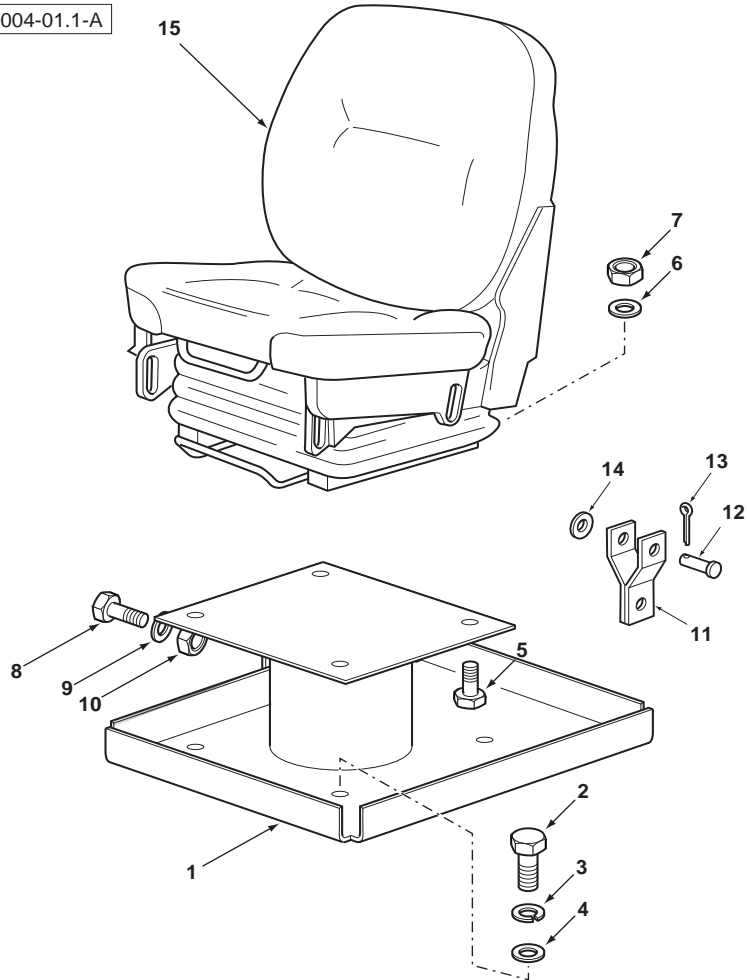

1	6108693M92		1	Pedestal	Socle	Zócalo
2	3009493X1	M10 x 30	4	Bolt	Boulon	Perno
3	339376X1	M10	4	Washer, Lock	Rondelle de blocage	Arandela de freno
4	390734X1	M10	4	Washer	Rondelle	Arandela
5	339761X1	M8 x 25	4	Screw	Vis	Tornillo
6	390972X1	M8	4	Washer	Rondelle	Arandela
7	394367X1	M8	4	Nut, Lock	Écrou de blocage	Tuerca de retención
8	3009493X1	M10 x 30	2	Bolt	Boulon	Perno
9	390734X1	M10	2	Washer	Rondelle	Arandela
10	1440329X1	M10	2	Nut, Lock	Écrou de blocage	Tuerca de retención
11	6109682M1		2	Link	Maillon	Eslabón
12	3019198X1		1	Pin	Axe	Pasador
13	1442864X1		1	Pin, Split	Goupille	Pasador
14	390972X1	M8	1	Washer	Rondelle	Arandela
15	6108906M91	62004C02.1 1	1	Seat Assy	Ensemble des sièges	Asiento, Conj.



820
TX760B

806 808 834

62004C01.1

6199042M3

1

Jan-06

Seat
Siège
Asiento

Weatherproof P.V.C. Trim
Finition P.V.C. Étanche
Tapizado de PVC

4 Post ROPS
4 Poteau ROPS
4 poste ROPS

C-62003-02.1-A

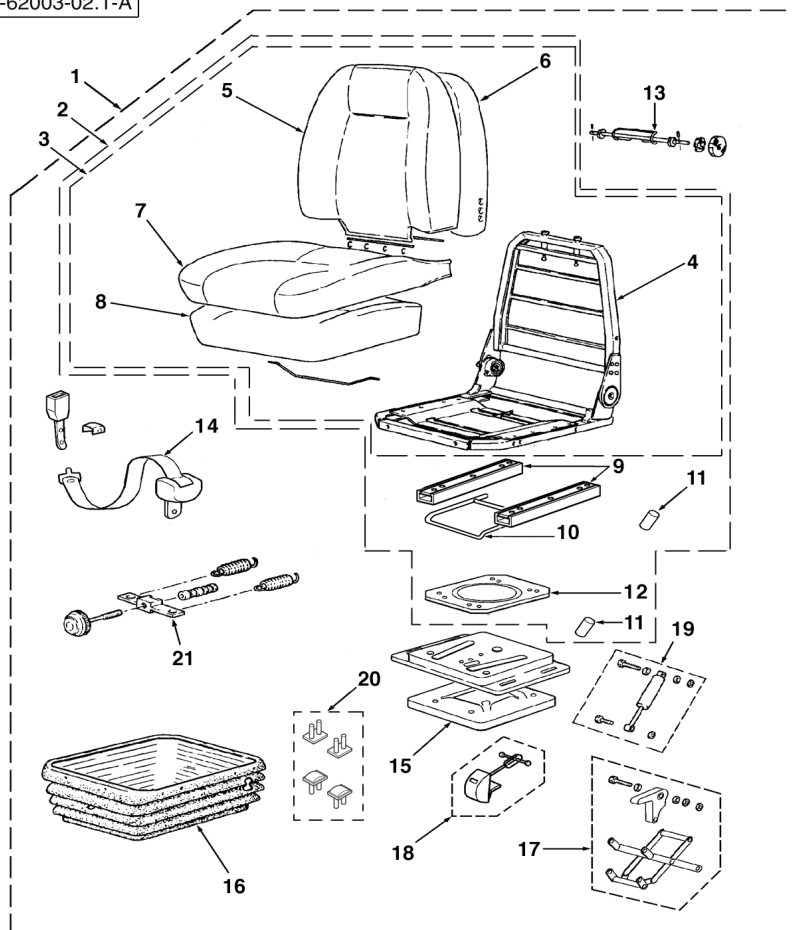

1	6108906M91		62003C01.1 11	1	Seat Assy	Ensemble des sièges	Asiento, Conj.
2	6193723M91	1		1	Seat	Siège	Asiento
3	6193725M91	2		1	Seat	Siège	Asiento
4	6193726M91	3		1	Frame Assy	Ensemble de bâti	Bastidor, Conj.
5	6190726M91	3		1	Cushion, Backrest	Coussin de dossier	Cojín de respaldo
6	6190707M91	3		1	Backrest	Dossier	Respaldo
7	6193729M91	3		1	Cover, Seat	Housse	Cubre asiento
8	6190728M91	3		1	Seat	Siège	Asiento
9	6193731M91	2		1	Slide	Glissière	Corredera
10	6193732M91	2		1	Handle Assy	Ensemble de poignée	Empuñadura, Conj.
11	6193730M1	2		2	Handle	Poignée	Asa
12	6193733M91	2		1	Frame, Turntable	Bâti tourelle	Bastidor torreta
13	6190711M91	1		1	Kit, Parts	Lot de pièces	Juego de piezas
14	6190710M91	1		1	Belt, Seat	Ceinture de sécurité	Cinturón, Seguridad
15	6190718M91	1		1	Suspension	Suspension	Suspensión
16	6190719M91	1		1	Boot	Soufflet	Fuelle
17	6190720M91	1		1	Kit, Parts	Lot de pièces	Juego de piezas
18	6190721M91	1		1	Handle	Poignée	Asa
19	6190722M91	1		1	Shock Absorber	Amortisseur	Amortiguador
20	6190723M91	1		1	Middlebuster	Buteur	Aporcador
21	6190724M91	1		1	Handle	Poignée	Asa



820 860 880
TX760B TX860B
TX870B

802 804 810 812 814 816 822 824 832 842 844 852 854

62003C02.1

6199042M3

1

Jan-06

Seat
Siège
Asiento

Weatherproof P.V.C. Trim
Finition P.V.C. Étanche
Tapizado de PVC

4 Post ROPS
4 Poteau ROPS
4 poste ROPS

C-62004-02.1-A

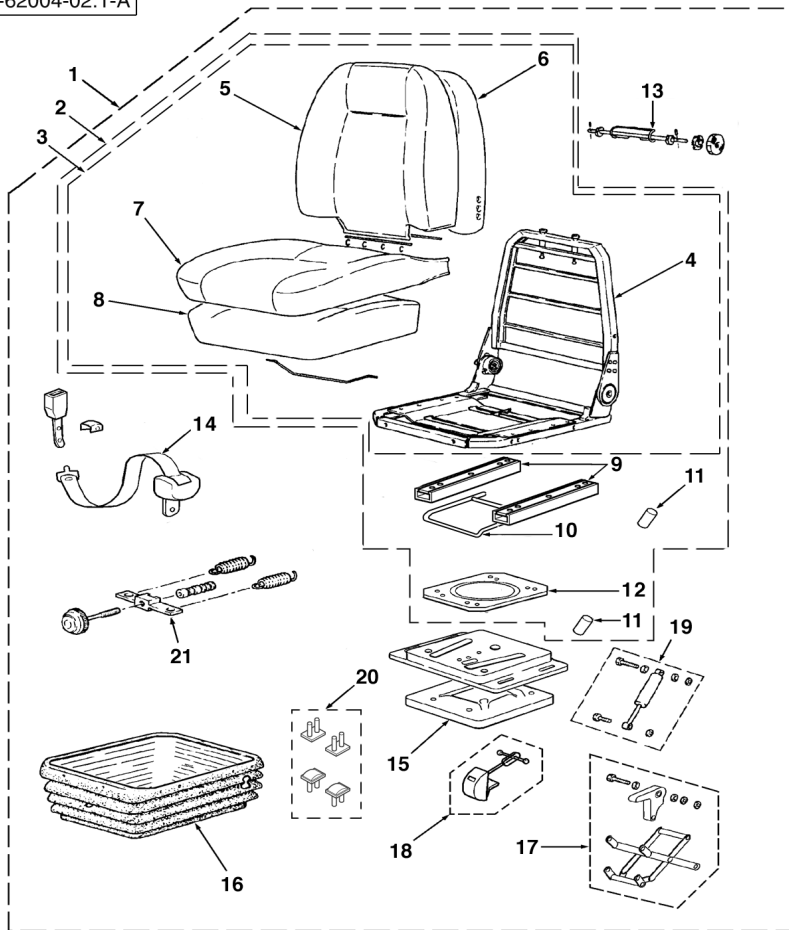

1	6108906M91		62004C01.1 15	1	Seat Assy	Ensemble des sièges	Asiento, Conj.
2	6193723M91	1		1	Seat	Siège	Asiento
3	6193725M91	2		1	Seat	Siège	Asiento
4	6193726M91	3		1	Frame Assy	Ensemble de bâti	Bastidor, Conj.
5	6190726M91	3		1	Cushion, Backrest	Coussin de dossier	Cojín de respaldo
6	6190707M91	3		1	Backrest	Dossier	Respaldo
7	6193729M91	3		1	Cover, Seat	Housse	Cubre asiento
8	6190728M91	3		1	Seat	Siège	Asiento
9	6193731M91	2		1	Slide	Glissière	Corredera
10	6193732M91	2		1	Handle Assy	Ensemble de poignée	Empuñadura, Conj.
11	6193730M1	2		2	Handle	Poignée	Asa
12	6193733M91	2		1	Frame, Turntable	Bâti tourelle	Bastidor torreta
13	6190711M91	1		1	Kit, Parts	Lot de pièces	Juego de piezas
14	6190710M91	1		1	Belt, Seat	Ceinture de sécurité	Cinturón, Seguridad
15	6190718M91	1		1	Suspension	Suspension	Suspensión
16	6190719M91	1		1	Boot	Soufflet	Fuelle
17	6190720M91	1		1	Kit, Parts	Lot de pièces	Juego de piezas
18	6190721M91	1		1	Handle	Poignée	Asa
19	6190722M91	1		1	Shock Absorber	Amortisseur	Amortiguador
20	6190723M91	1		1	Middlebuster	Buteur	Aporcador
21	6190724M91	1		1	Handle	Poignée	Asa



820
TX760B

806 808 834

62004C02.1

6199042M3

1

Jan-06

Side Console
Console Latérale
Consola lateral

Switchpack
Ensemble Aiguille
Paquete de cambio

C-56010-01.1-A

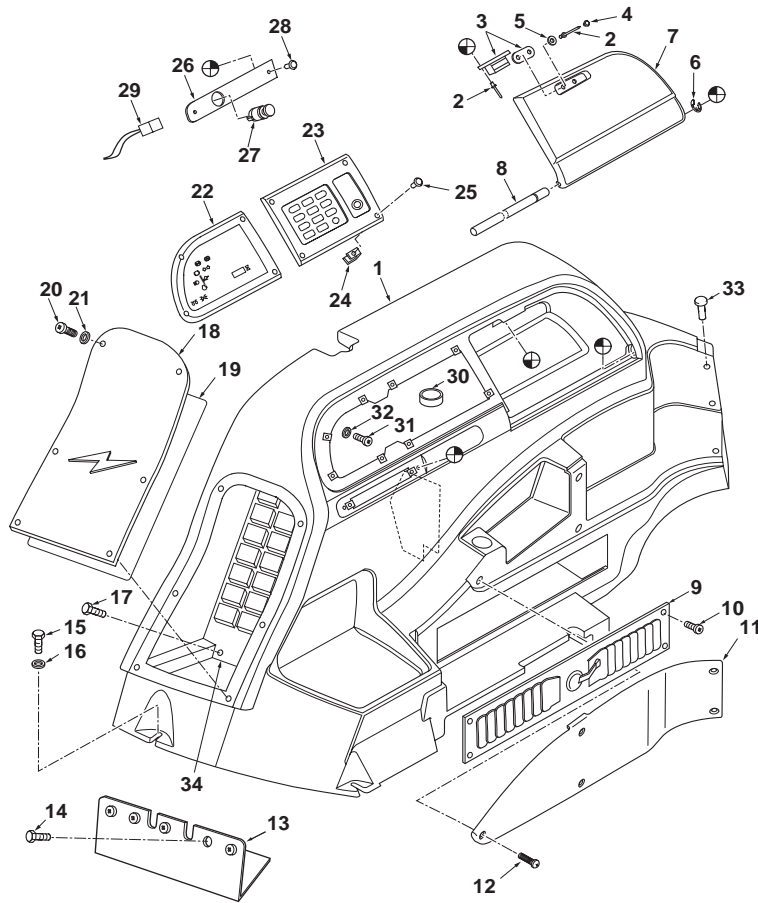

1	6101710M94		1	Console	Console	Consola	
2	371803X1	1	4	Rivet	Rivet	Remache	
3	6101592M91	1	1	Magnet	Aimant	Imán	
4	6101622M1	1	2	Cap	Chapeau	Sombbrero	
5	6101623M1	1	2	Washer	Rondelle	Arandela	
6	3000115X1	1	1	Circlip	Segment d'arrêt	Circlip	
7	6099520M1	1	1	Cover	Cache	Tapa	
8	6101630M1	1	1	Rod	Tringle	Vástago	
9	6101500M2	1	1	Grille	Grille	Rejilla	
10	3522735M4	1	M3 x 16	4	Screw	Vis	Tornillo
11	6099519M1			1	Cover	Cache	Tapa
12	6101591M1		Plastic	5	Rivet	Rivet	Remache
13	6110203M1			1	Bracket	Patte de fixation	Pata de fijación
14	1472524M2			4	Screw	Vis	Tornillo
15	339804X1		M6 x 25	2	Screw	Vis	Tornillo
16	3516109M1			2	Washer	Rondelle	Arandela
17	1472524M2			2	Screw	Vis	Tornillo
18	6102584M91			1	Cover Assy	Ensemble de couvercle	Tapa, Conj.
19	6108758M1			1	Decal	Adhésif	Adhesivo
20	6102921M1		M5 x 20	6	Screw	Vis	Tornillo
21	3512553M1		M5	6	Washer	Rondelle	Arandela
22	6110488M91			1	Instrument Pack	Groupe d'instr. de bord	Grupo instrs. abordo
23	6109511M91		56010C02.1 1	1	Switchpack	Paquet de commut.	Paquete de cambio
24	6101590M1		M4	8	Nut, U	Écrou en U	Tuerca en U
25	365919X1			8	Screw	Vis	Tornillo
26	6101153M2			1	Plate	Plaque	Placa
27	3517053M91			1	Cigar Lighter	Allume-cigares	Encendedor de cig.
28	3521786M3		M4 x 10	2	Screw	Vis	Tornillo
29	6102229M92			1	Harness Assy	Ensemble de faisceau	Haz, Conj.
30	6102479M1			1	Grommet	Passe-fil	Pasa cable
31	339560X1		M6 x 16	1	Screw	Vis	Tornillo
32	391038X1		M6	1	Washer	Rondelle	Arandela
33	6101591M1		Plastic	3	Rivet	Rivet	Remache
34	6108707M91		56010C03.1 1	1	Fuse/Relay Board	Tableau fus./relais	Tablero fusibles/relés



820 860 880
TX760B TX860B
TX870B

805 807 817 825 833 841 843 845 851 853 855

56010C01.1

6199042M3

1

Jan-06

Side Console
Console Latérale
Consola lateral

Switchpack
Ensemble Aiguille
Paquete de cambio

C-56011-01.1-A

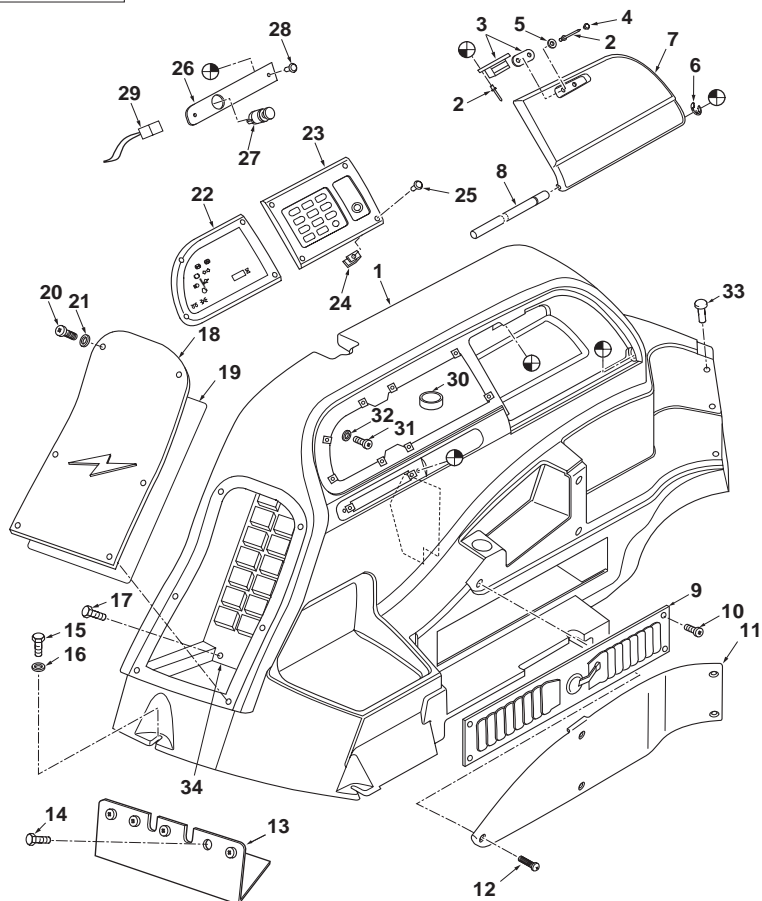

1	6101710M94		1	Console	Console	Consola	
2	371803X1	1	4	Rivet	Rivet	Remache	
3	6101592M91	1	1	Magnet	Aimant	Imán	
4	6101622M1	1	2	Cap	Chapeau	Sombbrero	
5	6101623M1	1	2	Washer	Rondelle	Arandela	
6	3000115X1	1	1	Circlip	Segment d'arrêt	Circlip	
7	6099520M1	1	1	Cover	Cache	Tapa	
8	6101630M1	1	1	Rod	Tringle	Vástago	
9	6101500M2	1	1	Grille	Grille	Rejilla	
10	3522735M4	1	M3 x 16	4	Screw	Vis	Tornillo
11	6099519M1		1	Cover	Cache	Tapa	
12	6101591M1		Plastic	5	Rivet	Rivet	Remache
13	6110203M1		1	Bracket	Patte de fixation	Pata de fijación	
14	1472524M2		4	Screw	Vis	Tornillo	
15	339804X1		M6 x 25	2	Screw	Vis	Tornillo
16	3516109M1		2	Washer	Rondelle	Arandela	
17	1472524M2		2	Screw	Vis	Tornillo	
18	6102584M91		1	Cover Assy	Ensemble de couvercle	Tapa, Conj.	
19	6108758M1		1	Decal	Adhésif	Adhesivo	
20	6102921M1		M5 x 20	6	Screw	Vis	Tornillo
21	3512553M1		M5	6	Washer	Rondelle	Arandela
22	6110488M91		1	Instrument Pack	Groupe d'instr. de bord	Grupo instrs. abordo	
23	6109509M93		56011C02.1 1	1	Switchpack	Paquet de commut.	Paquete de cambio
24	6101590M1		M4	8	Nut, U	Écrou en U	Tuerca en U
25	365919X1		8	Screw	Vis	Tornillo	
26	6101153M2		1	Plate	Plaque	Placa	
27	3517053M91		1	Cigar Lighter	Allume-cigares	Encendedor de cig.	
28	3521786M3		M4 x 10	2	Screw	Vis	Tornillo
29	6102229M92		1	Harness Assy	Ensemble de faisceau	Haz, Conj.	
30	6102479M1		1	Grommet	Passe-fil	Pasa cable	
31	339560X1		M6 x 16	1	Screw	Vis	Tornillo
32	391038X1		M6	1	Washer	Rondelle	Arandela
33	6101591M1		Plastic	3	Rivet	Rivet	Remache
34	6108707M91		56011C03.1 1	1	Fuse/Relay Board	Tableau fus./relais	Tablero fusibles/relés



820 860 880
TX760B TX860B
TX870B

801 803 809 811 813 815 821 823 831 841 843 851 853

56011C01.1

6199042M3

1

Jan-06

Side Console
Console Latérale
Consola lateral

Switchpack
Ensemble Aiguille
Paquete de cambio

C-56012-01.1-A

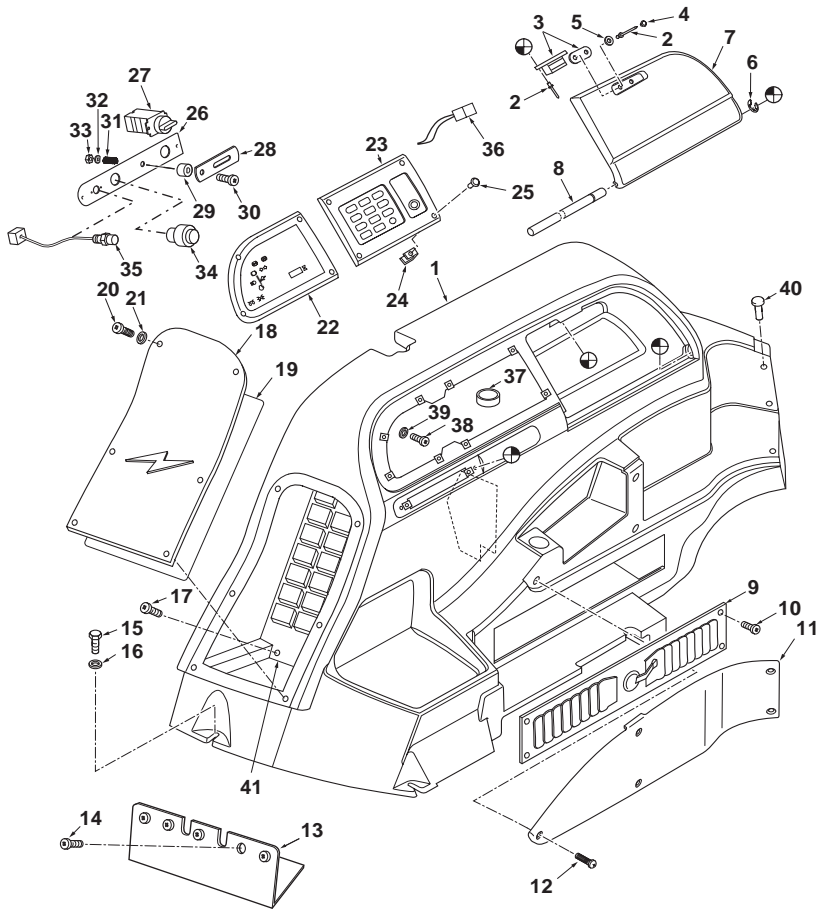

1	6101710M94		1	Console	Console	Consola	
2	371803X1	1	4	Rivet	Rivet	Remache	
3	6101592M91	1	1	Magnet	Aimant	Imán	
4	6101622M1	1	2	Cap	Chapeau	Sombbrero	
5	6101623M1	1	2	Washer	Rondelle	Arandela	
6	3000115X1	1	1	Circlip	Segment d'arrêt	Circlip	
7	6099520M1	1	1	Cover	Cache	Tapa	
8	6101630M1	1	1	Rod	Tringle	Vástago	
9	6101500M2	1	1	Grille	Grille	Rejilla	
10	3522735M4	1	M3 x 16	4	Screw	Vis	Tornillo
11	6099519M1			1	Cover	Cache	Tapa
12	6101591M1		Plastic	5	Rivet	Rivet	Remache
13	6110203M1			1	Bracket	Patte de fixation	Pata de fijación
14	1472524M2			4	Screw	Vis	Tornillo
15	339804X1		M6 x 25	2	Screw	Vis	Tornillo
16	3516109M1			2	Washer	Rondelle	Arandela
17	1472524M2			2	Screw	Vis	Tornillo
18	6102584M91			1	Cover Assy	Ensemble de couvercle	Tapa, Conj.
19	6108758M1			1	Decal	Adhésif	Adhesivo
20	6102921M1		M5 x 20	6	Screw	Vis	Tornillo
21	3512553M1		M5	6	Washer	Rondelle	Arandela
22	6110488M91			1	Instrument Pack	Groupe d'instr. de bord	Grupo instrs. abordo
23	6109511M91		56012C02.1 1	1	Switchpack	Paquet de commut.	Paquete de cambio
24	6101590M1		M4	8	Nut, U	Écrou en U	Tuerca en U
25	365919X1			8	Screw	Vis	Tornillo
26	6110012M1			1	Plate	Plaque	Placa
27	6110002M91			1	Switch Assy	Ensemble commutat.	Conmutador, Conj.
28	6101703M2			1	Lever	Levier	Palanca
29	3516528M1			1	Spacer	Entretoise	Traviesa
30	3009542X1		M6 x 45	1	Screw	Vis	Tornillo
31	3516529M1			1	Spring	Ressort	Muelle
32	390971X1		M6	1	Washer	Rondelle	Arandela
33	1441500X1		M6	1	Nut, Lock	Écrou de blocage	Tuerca de retención
34	3517053M91			1	Cigar Lighter	Allume-cigares	Encendedor de cig.
35	6109850M92			1	Harness Assy	Ensemble de faisceau	Haz, Conj.
36	6102229M92			1	Harness Assy	Ensemble de faisceau	Haz, Conj.
37	6102479M1			1	Grommet	Passe-fil	Pasa cable
38	339560X1		M6 x 16	1	Screw	Vis	Tornillo
39	391038X1		M6	1	Washer	Rondelle	Arandela
40	6101591M1		Plastic	3	Rivet	Rivet	Remache
41	6108707M91		56012C03.1 1	1	Fuse/Relay Board	Tableau fus./relais	Tablero fusibles/relés



880 970 980
TX860B TX870B

845 851 853 855 921 931

56012C01.1

6199042M3

1

Jan-06

Side Console
Console Latérale
Consola lateral

Switchpack
Ensemble Aiguille
Paquete de cambio

C-56013-01.1-A

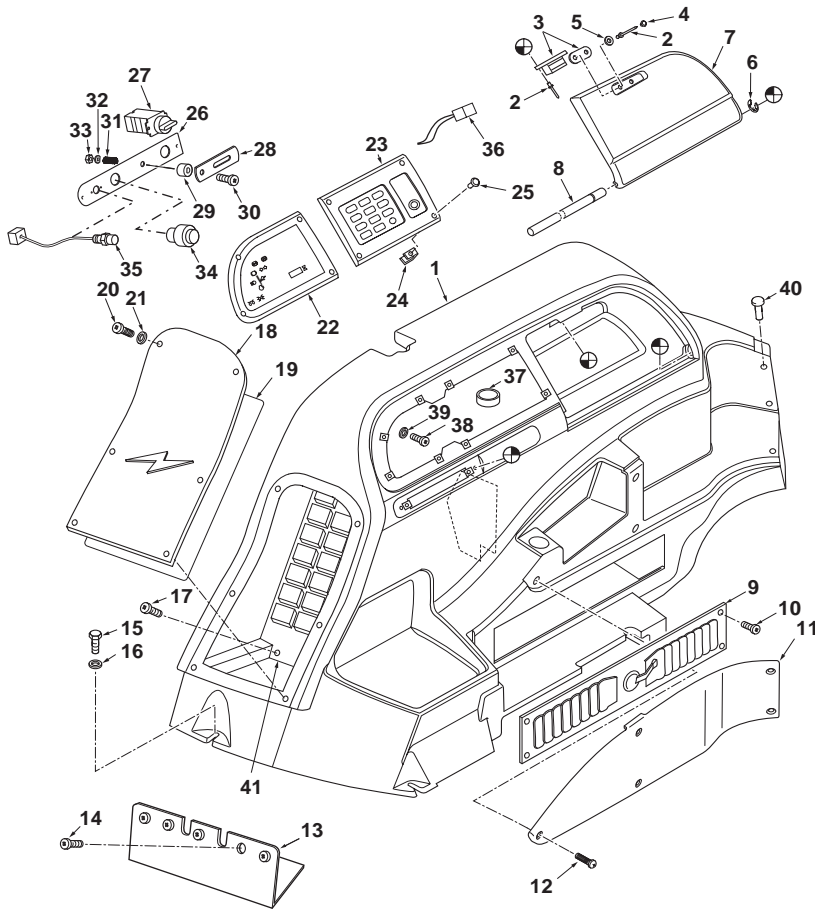

1	6101710M94		1	Console	Console	Consola
2	371803X1	1	4	Rivet	Rivet	Remache
3	6101592M91	1	1	Magnet	Aimant	Imán
4	6101622M1	1	2	Cap	Chapeau	Sombbrero
5	6101623M1	1	2	Washer	Rondelle	Arandela
6	3000115X1	1	1	Circlip	Segment d'arrêt	Circlip
7	6099520M1	1	1	Cover	Cache	Tapa
8	6101630M1	1	1	Rod	Tringle	Vástago
9	6101500M2	1	1	Grille	Grille	Rejilla
10	3522735M4	1	4	Screw	Vis	Tornillo
11	6099519M1		1	Cover	Cache	Tapa
12	6101591M1	Plastic	5	Rivet	Rivet	Remache
13	6110203M1		1	Bracket	Patte de fixation	Pata de fijación
14	1472524M2		4	Screw	Vis	Tornillo
15	339804X1	M6 x 25	2	Screw	Vis	Tornillo
16	3516109M1		2	Washer	Rondelle	Arandela
17	1472524M2		2	Screw	Vis	Tornillo
18	6102584M91		1	Cover Assy	Ensemble de couvercle	Tapa, Conj.
19	6108758M1		1	Decal	Adhésif	Adhesivo
20	6102921M1	M5 x 20	6	Screw	Vis	Tornillo
21	3512553M1	M5	6	Washer	Rondelle	Arandela
22	6110488M91		1	Instrument Pack	Groupe d'instr. de bord	Grupo instrs. abordo
23	6109509M93	56013C02.1 1	1	Switchpack	Paquet de commut.	Paquete de cambio
24	6101590M1	M4	8	Nut, U	Écrou en U	Tuerca en U
25	365919X1		8	Screw	Vis	Tornillo
26	6110012M1		1	Plate	Plaque	Placa
27	6110002M91		1	Switch Assy	Ensemble commutat.	Conmutador, Conj.
28	6101703M2		1	Lever	Levier	Palanca
29	3516528M1		1	Spacer	Entretoise	Traviesa
30	3009542X1	M6 x 45	1	Screw	Vis	Tornillo
31	3516529M1		1	Spring	Ressort	Muelle
32	390971X1	M6	1	Washer	Rondelle	Arandela
33	1441500X1	M6	1	Nut, Lock	Écrou de blocage	Tuerca de retención
34	3517053M91		1	Cigar Lighter	Allume-cigares	Encendedor de cig.
35	6109850M92		1	Harness Assy	Ensemble de faisceau	Haz, Conj.
36	6102229M92		1	Harness Assy	Ensemble de faisceau	Haz, Conj.
37	6102479M1		1	Grommet	Passe-fil	Pasa cable
38	339560X1	M6 x 16	1	Screw	Vis	Tornillo
39	391038X1	M6	1	Washer	Rondelle	Arandela
40	6101591M1	Plastic	3	Rivet	Rivet	Remache
41	6108707M91	56013C03.1 1	1	Fuse/Relay Board	Tableau fus./relais	Tablero fusibles/relés



880 970 980
TX860B TX870B
TX970B

851 853 922 923 932

56013C01.1

6199042M3

1

Jan-06

Side Console
Console Latérale
Consola lateral

4 Post ROPS
4 Poteau ROPS
4 poste ROPS

C-56014-01.1-B

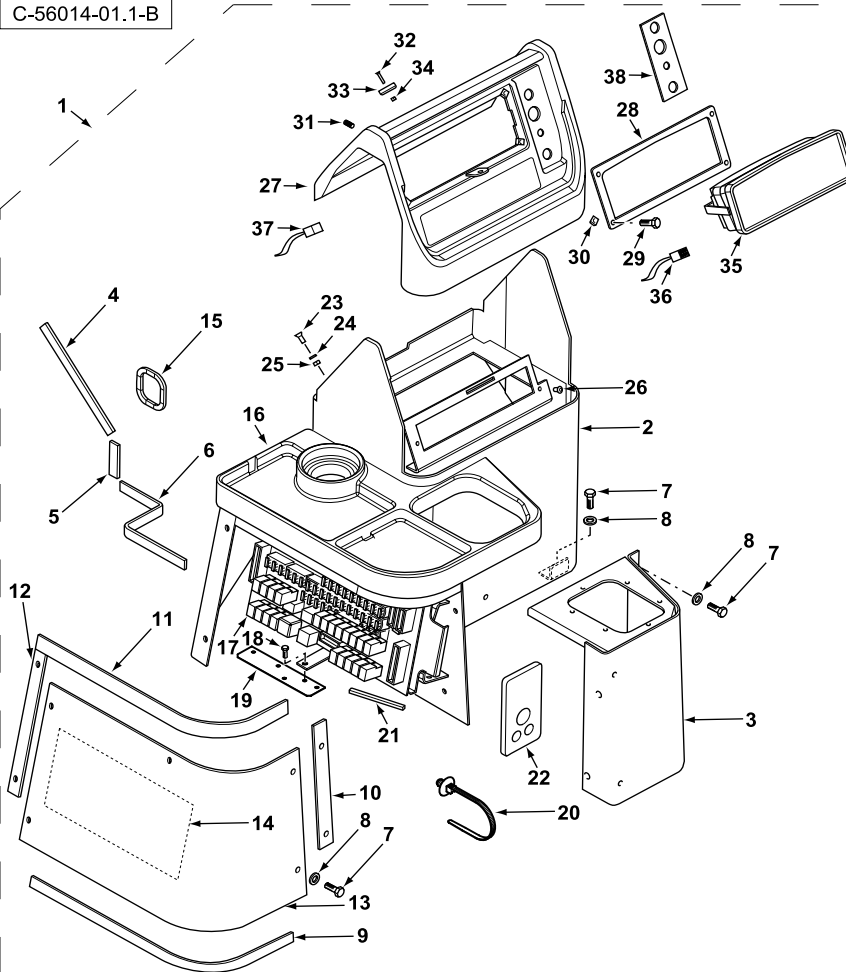

1	6110294M91			1	Console	Console	Consola
2	6108229M92	1		1	Console	Console	Consola
3	6108228M91	1		1	Support Assy	Ensemble de support	Apoyadero, Conj.
4	6108721M1	1		1	Seal	Joint	Junta
5	6108720M1	1		1	Seal	Joint	Junta
6	6108719M1	1		1	Seal	Joint	Junta
7	339123X1	1	M8 x 20	13	Bolt	Boulon	Perno
8	390972X1	1	M8	13	Washer	Rondelle	Arandela
9	6108722M1	1		1	Seal	Joint	Junta
10	6108739M1	1		1	Seal	Joint	Junta
11	6108738M1	1		1	Seal	Joint	Junta
12	6108740M1	1		1	Seal	Joint	Junta
13	6108205M2	1		1	Cover	Cache	Tapa
14	6108758M1	1		1	Decal	Adhésif	Adhesivo
15	6108732M1	1		1	Strip, Sealing	Bande d'étanchéité	Banda estanqueidad
16	6108206M2	1		1	Mat	Tapis	Tapete
17	6108707M91	1	56014C03.1 1	1	Fuse/Relay Board	Tableau fus./relais	Tablero fusibles/relés
18	392409X1	1	Pan Hd M5 x 6	5	Screw	Vis	Tornillo
19	6110491M91	1		1	Bracket Assy	Ensemble chaise palier	Cuchara, Conj.
20	6102985M1	1	Fir tree	X	Tie, Cable	Attache câble	Enlace de Cable
21	6108733M1	1		2	Strip, Sealing	Bande d'étanchéité	Banda estanqueidad
22	6108881M1	1		1	Foam	Mousse	Espuma
23	385427X1	1	M6 x 16	2	Screw	Vis	Tornillo
24	339375X1	1	M6	2	Washer, Lock	Rondelle de blocage	Arandela de freno
25	339030X1	1	M6	2	Nut	Écrou	Tuerca
26	3512494M1	1	M6 x 12	2	Screw	Vis	Tornillo
27	6108186M2	1	56014C02.1 18	1	Panel, Instrument	Tableau de bord	Tablero instrumentos
28	6108517M1	1		1	Plate	Plaque	Placa
29	6109560M1	1		4	Screw	Vis	Tornillo
30	6101590M1	1	M4	4	Nut, U	Écrou en U	Tuerca en U
31	3005606X1	1	M4 x 6	2	Set screw	Vis de réglage	Tornillo de ajuste
32	3009659X1	1	M4 x 20	1	Screw	Vis	Tornillo
33	6108759M2	1		1	Magnet	Aimant	Imán
34	3019139X1	1	M4	1	Nut	Écrou	Tuerca
35	6110487M91	1		1	Instrument Pack	Groupe d'instr. de bord	Grupo instrs. abordo
36	6108776M91	1	Instrument Pack	1	Harness Assy	Ensemble de faisceau	Haz, Conj.
37	6110205M91	1	Ignition	1	Harness Assy	Ensemble de faisceau	Haz, Conj.
38	6108750M2	1		1	Plate	Plaque	Placa



820 860
TX760B TX860B
TX870B

802 804 810 812 814 816 822 824 832

56014C01.1

6199042M3

1

Jan-06

Side Console
Console Latérale
Consola lateral

4 Post ROPS
4 Poteau ROPS
4 poste ROPS

C-56015-01.1-B

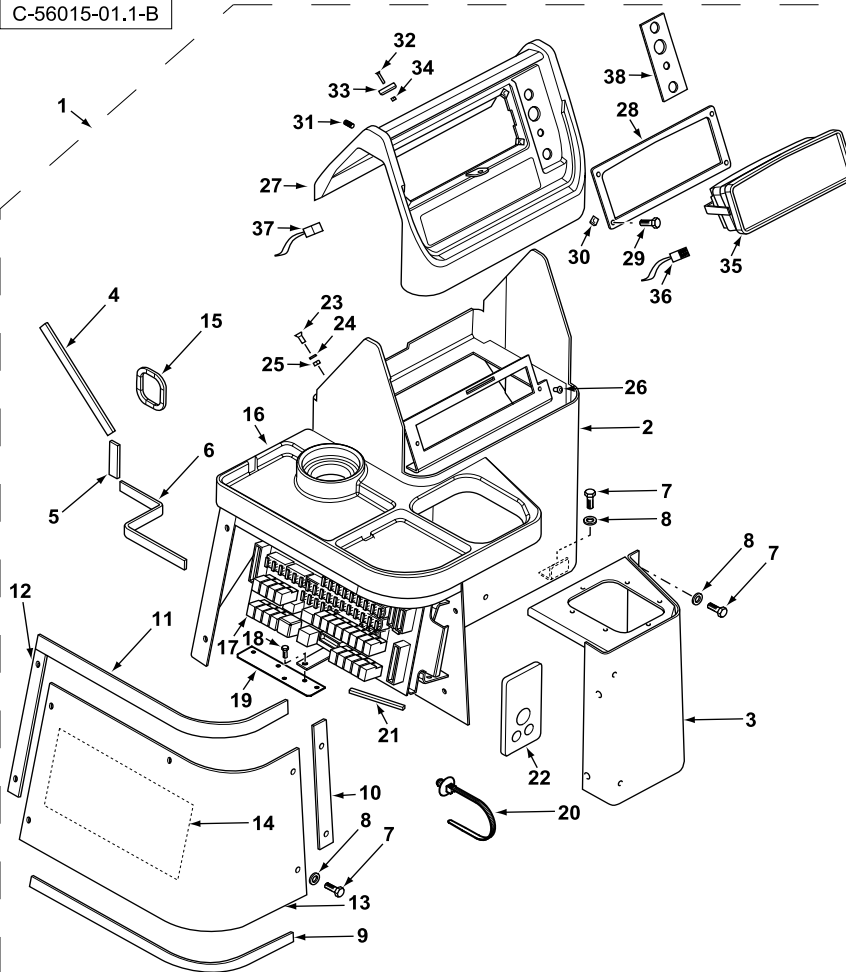

1	6110295M91			1	Console	Console	Consola
2	6108229M92	1		1	Console	Console	Consola
3	6108228M91	1		1	Support Assy	Ensemble de support	Apoyadero, Conj.
4	6108721M1	1		1	Seal	Joint	Junta
5	6108720M1	1		1	Seal	Joint	Junta
6	6108719M1	1		1	Seal	Joint	Junta
7	339123X1	1	M8 x 20	13	Bolt	Boulon	Perno
8	390972X1	1	M8	13	Washer	Rondelle	Arandela
9	6108722M1	1		1	Seal	Joint	Junta
10	6108739M1	1		1	Seal	Joint	Junta
11	6108738M1	1		1	Seal	Joint	Junta
12	6108740M1	1		1	Seal	Joint	Junta
13	6108205M2	1		1	Cover	Cache	Tapa
14	6108758M1	1		1	Decal	Adhésif	Adhesivo
15	6108732M1	1		1	Strip, Sealing	Bande d'étanchéité	Banda estanqueidad
16	6108206M2	1		1	Mat	Tapis	Tapete
17	6108707M91	1	56015C03.1 1	1	Fuse/Relay Board	Tableau fus./relais	Tablero fusibles/relés
18	392409X1	1	Pan Hd M5 x 6	5	Screw	Vis	Tornillo
19	6110491M91	1		1	Bracket Assy	Ensemble chaise palier	Cuchara, Conj.
20	6102985M1	1	Fir tree	2	Tie, Cable	Attache câble	Enlace de Cable
21	6108733M1	1		2	Strip, Sealing	Bande d'étanchéité	Banda estanqueidad
22	6108881M1	1		1	Foam	Mousse	Espuma
23	385427X1	1	M6 x 16	2	Screw	Vis	Tornillo
24	339375X1	1	M6	2	Washer, Lock	Rondelle de blocage	Arandela de freno
25	339030X1	1	M6	2	Nut	Écrou	Tuerca
26	3512494M1	1	M6 x 12	2	Screw	Vis	Tornillo
27	6108186M2	1	56015C02.1 18	1	Panel, Instrument	Tableau de bord	Tablero instrumentos
28	6108517M1	1		1	Plate	Plaque	Placa
29	6109560M1	1		4	Screw	Vis	Tornillo
30	6101590M1	1	M4	4	Nut, U	Écrou en U	Tuerca en U
31	3005606X1	1	M4 x 6	2	Set screw	Vis de réglage	Tornillo de ajuste
32	3009659X1	1	M4 x 20	1	Screw	Vis	Tornillo
33	6108759M2	1		1	Magnet	Aimant	Imán
34	3019139X1	1	M4	1	Nut	Écrou	Tuerca
35	6110487M91	1		1	Instrument Pack	Groupe d'instr. de bord	Grupo instrs. abordo
36	6108776M91	1	Instrument Pack	1	Harness Assy	Ensemble de faisceau	Haz, Conj.
37	6110205M91	1	Ignition	1	Harness Assy	Ensemble de faisceau	Haz, Conj.
38	6108750M2	1		1	Plate	Plaque	Placa



820
TX760B

806 808 834

56015C01.1

6199042M3

1

Jan-06

Side Console
Console Latérale
Consola lateral

Fuse & Relay Board
Tableau de Fusibles & Relais
Tablero de fusibles y relés

C-56010-03.1-A

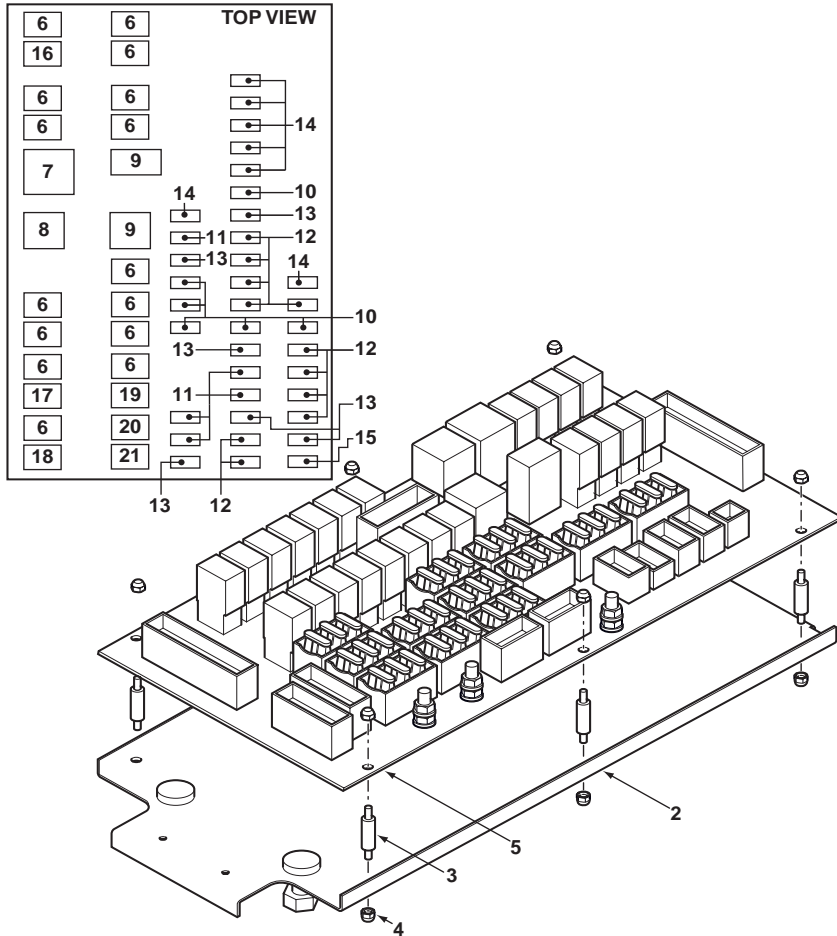

1	6108707M91		56010C01.1 34	1	Fuse/Relay Board	Tableau fus./relais	Tablero fusibles/relés
2		1	Ref.1	1	Plate	Plaque	Placa
3	6102558M1	1		8	Support, Panel	Support de tableau	SopORTE de panel
4	3009074X1	1	M4	16	Nut, Lock	Écrou de blocage	Tuerca de retención
5		1	Ref.1	1	Fuse/Relay Board	Tableau fus./relais	Tablero fusibles/relés
6	6102490M1	5		17	Relay	Relais	Relé
7	6108737M1	5		1	Relay	Relais	Relé
8	6102648M1	5		1	Relay	Relais	Relé
9	6102496M1	5		2	Relay	Relais	Relé
10	6108756M1	5	3 amp	6	Fuse	Fusible	Fusible
11	6108757M1	5	5 amp	6	Fuse	Fusible	Fusible
12	6108754M1	5	7,5 amp	11	Fuse	Fusible	Fusible
13	3523568M1	5	10A	6	Fuse	Fusible	Fusible
14	3523569M1	5	15A	7	Fuse	Fusible	Fusible
15	3523571M1	5	25A	1	Fuse	Fusible	Fusible
16	6102490M1	5	"Hose Burst"	1	Relay	Relais	Relé
17	6102490M1	5	"Loader Q/Attach"	1	Relay	Relais	Relé
18	6102490M1	5	"Digger Q/Attach"	1	Relay	Relais	Relé
19	6102490M1	5	"4WD"	1	Relay	Relais	Relé
20	6102490M1	5	"Ride Control"	1	Relay	Relais	Relé
21	6102490M1	5	"Hose Burst"	1	Relay	Relais	Relé



820 860 880
TX760B TX860B
TX870B

805 807 817 825 833 841 843 845 851 853 855

56010C03.1

6199042M3

1

Jan-06

Side Console
Console Latérale
Consola lateral

Fuse & Relay Board
Tableau de Fusibles & Relais
Tablero de fusibles y relés

C-56011-03.1-A

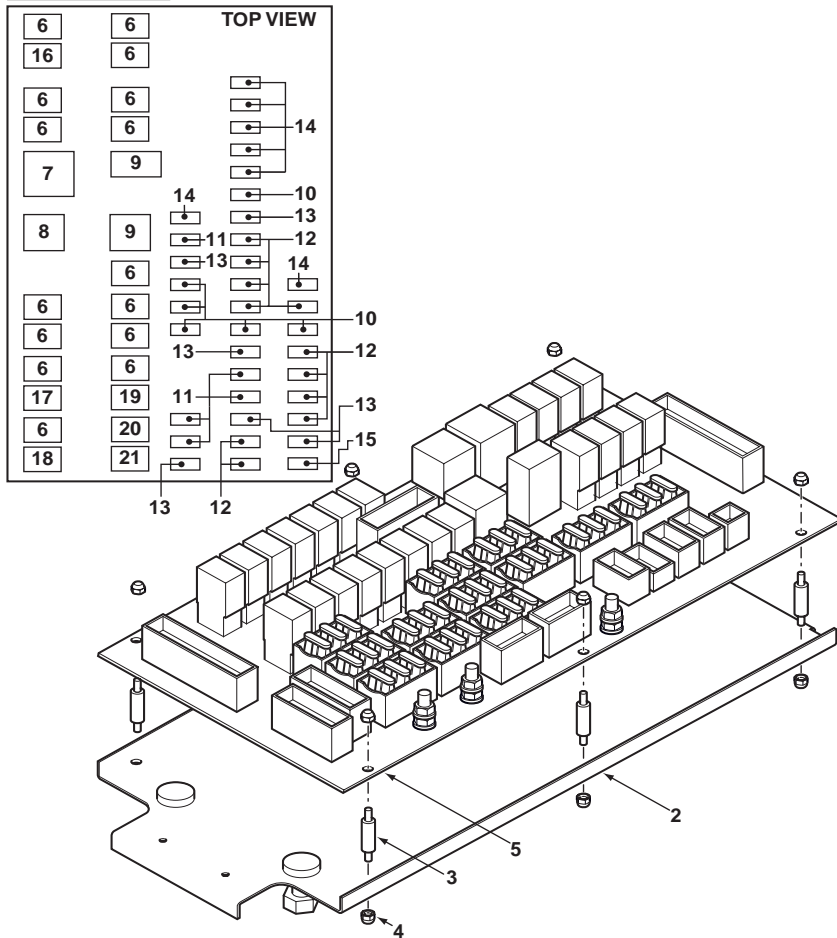

1	6108707M91		56011C01.1 34	1	Fuse/Relay Board	Tableau fus./relais	Tablero fusibles/relés
2		1	Ref.1	1	Plate	Plaque	Placa
3	6102558M1	1		8	Support, Panel	Support de tableau	SopORTE de panel
4	3009074X1	1	M4	16	Nut, Lock	Écrou de blocage	Tuerca de retención
5		1	Ref.1	1	Fuse/Relay Board	Tableau fus./relais	Tablero fusibles/relés
6	6102490M1	5		17	Relay	Relais	Relé
7	6108737M1	5		1	Relay	Relais	Relé
8	6102648M1	5		1	Relay	Relais	Relé
9	6102496M1	5		2	Relay	Relais	Relé
10	6108756M1	5	3 amp	6	Fuse	Fusible	Fusible
11	6108757M1	5	5 amp	6	Fuse	Fusible	Fusible
12	6108754M1	5	7,5 amp	11	Fuse	Fusible	Fusible
13	3523568M1	5	10A	6	Fuse	Fusible	Fusible
14	3523569M1	5	15A	7	Fuse	Fusible	Fusible
15	3523571M1	5	25A	1	Fuse	Fusible	Fusible
16	6102490M1	5	"Hose Burst"	1	Relay	Relais	Relé
17	6102490M1	5	"Loader Q/Attach"	1	Relay	Relais	Relé
18	6102490M1	5	"Digger Q/Attach"	1	Relay	Relais	Relé
19	6102490M1	5	"4WD"	1	Relay	Relais	Relé
20	6102490M1	5	"Ride Control"	1	Relay	Relais	Relé
21	6102490M1	5	"Hose Burst"	1	Relay	Relais	Relé



820 860 880
TX760B TX860B
TX870B

801 803 809 811 813 815 821 823 831 841 843 851 853

56011C03.1

6199042M3

1

Jan-06

Side Console
Console Latérale
Consola lateral

Fuse & Relay Board
Tableau de Fusibles & Relais
Tablero de fusibles y relés

C-56012-03.1-A

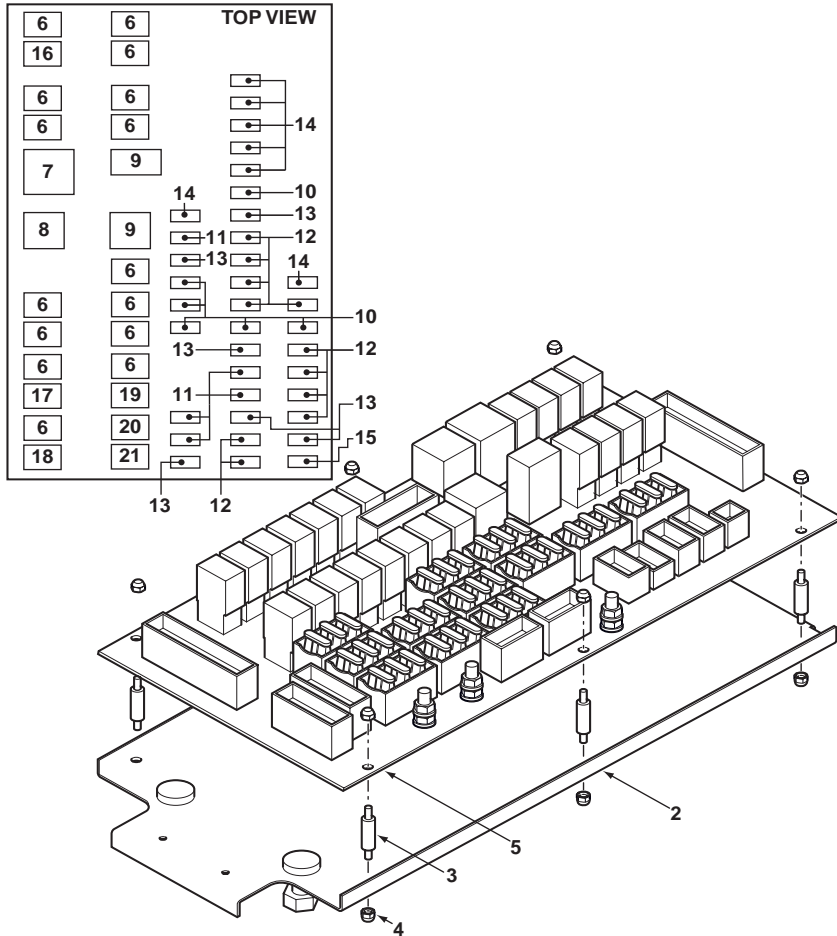

1	6108707M91		56012C01.1 41	1	Fuse/Relay Board	Tableau fus./relais	Tablero fusibles/relés
2		1	Ref.1	1	Plate	Plaque	Placa
3	6102558M1	1		8	Support, Panel	Support de tableau	SopORTE de panel
4	3009074X1	1	M4	16	Nut, Lock	Écrou de blocage	Tuerca de retención
5		1	Ref.1	1	Fuse/Relay Board	Tableau fus./relais	Tablero fusibles/relés
6	6102490M1	5		17	Relay	Relais	Relé
7	6108737M1	5		1	Relay	Relais	Relé
8	6102648M1	5		1	Relay	Relais	Relé
9	6102496M1	5		2	Relay	Relais	Relé
10	6108756M1	5	3 amp	6	Fuse	Fusible	Fusible
11	6108757M1	5	5 amp	6	Fuse	Fusible	Fusible
12	6108754M1	5	7,5 amp	11	Fuse	Fusible	Fusible
13	3523568M1	5	10A	6	Fuse	Fusible	Fusible
14	3523569M1	5	15A	7	Fuse	Fusible	Fusible
15	3523571M1	5	25A	1	Fuse	Fusible	Fusible
16	6102490M1	5	"Hose Burst"	1	Relay	Relais	Relé
17	6102490M1	5	"Loader Q/Attach"	1	Relay	Relais	Relé
18	6102490M1	5	"Digger Q/Attach"	1	Relay	Relais	Relé
19	6102490M1	5	"4WD"	1	Relay	Relais	Relé
20	6102490M1	5	"Ride Control"	1	Relay	Relais	Relé
21	6102490M1	5	"Hose Burst"	1	Relay	Relais	Relé



880 970 980
TX860B TX870B

845 851 853 855 921 931

56012C03.1

6199042M3

1

Jan-06

Side Console
Console Latérale
Consola lateral

Fuse & Relay Board
Tableau de Fusibles & Relais
Tablero de fusibles y relés

C-56013-03.1-A

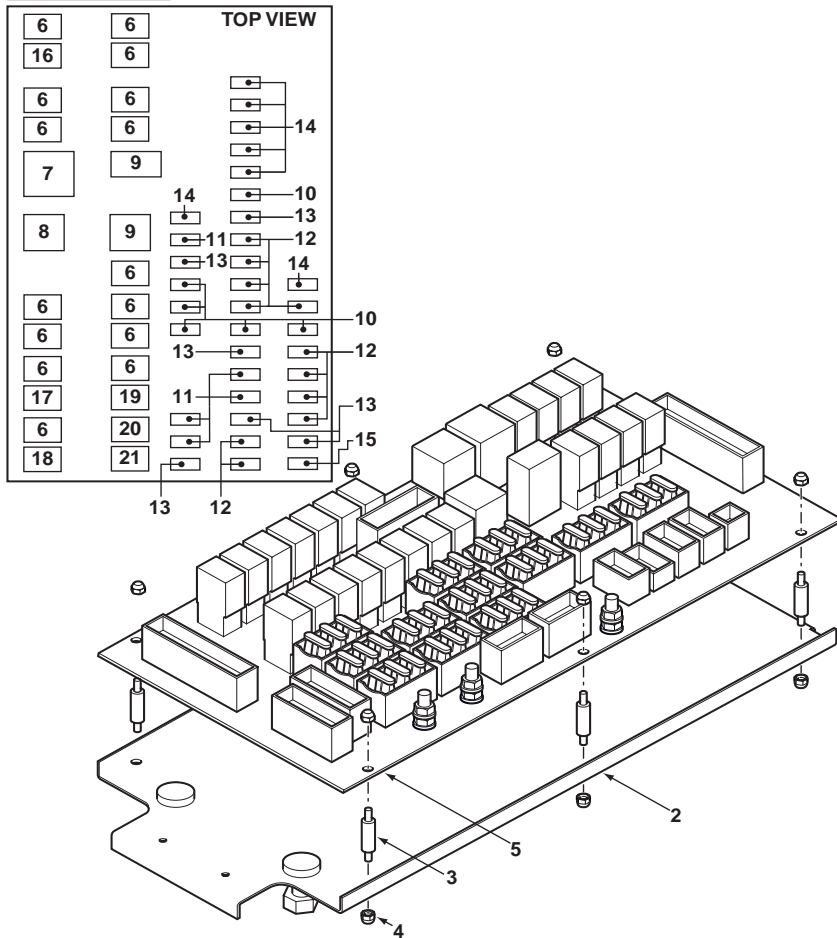

1	6108707M91		56013C01.1 41	1	Fuse/Relay Board	Tableau fus./relais	Tablero fusibles/relés
2		1	Ref.1	1	Plate	Plaque	Placa
3	6102558M1	1		8	Support, Panel	Support de tableau	SopORTE de panel
4	3009074X1	1	M4	16	Nut, Lock	Écrou de blocage	Tuerca de retención
5		1	Ref.1	1	Fuse/Relay Board	Tableau fus./relais	Tablero fusibles/relés
6	6102490M1	5		17	Relay	Relais	Relé
7	6108737M1	5		1	Relay	Relais	Relé
8	6102648M1	5		1	Relay	Relais	Relé
9	6102496M1	5		2	Relay	Relais	Relé
10	6108756M1	5	3 amp	6	Fuse	Fusible	Fusible
11	6108757M1	5	5 amp	6	Fuse	Fusible	Fusible
12	6108754M1	5	7,5 amp	11	Fuse	Fusible	Fusible
13	3523568M1	5	10A	6	Fuse	Fusible	Fusible
14	3523569M1	5	15A	7	Fuse	Fusible	Fusible
15	3523571M1	5	25A	1	Fuse	Fusible	Fusible
16	6102490M1	5	"Hose Burst"	1	Relay	Relais	Relé
17	6102490M1	5	"Loader Q/Attach"	1	Relay	Relais	Relé
18	6102490M1	5	"Digger Q/Attach"	1	Relay	Relais	Relé
19	6102490M1	5	"4WD"	1	Relay	Relais	Relé
20	6102490M1	5	"Ride Control"	1	Relay	Relais	Relé
21	6102490M1	5	"Hose Burst"	1	Relay	Relais	Relé



880 970 980
TX860B TX870B
TX970B

851 853 922 923 932

56013C03.1

6199042M3

1

Jan-06

Side Console
Console Latérale
Consola lateral

Fuse & Relay Board
Tableau de Fusibles & Relais
Tablero de fusibles y relés

C-56014-03.1-A

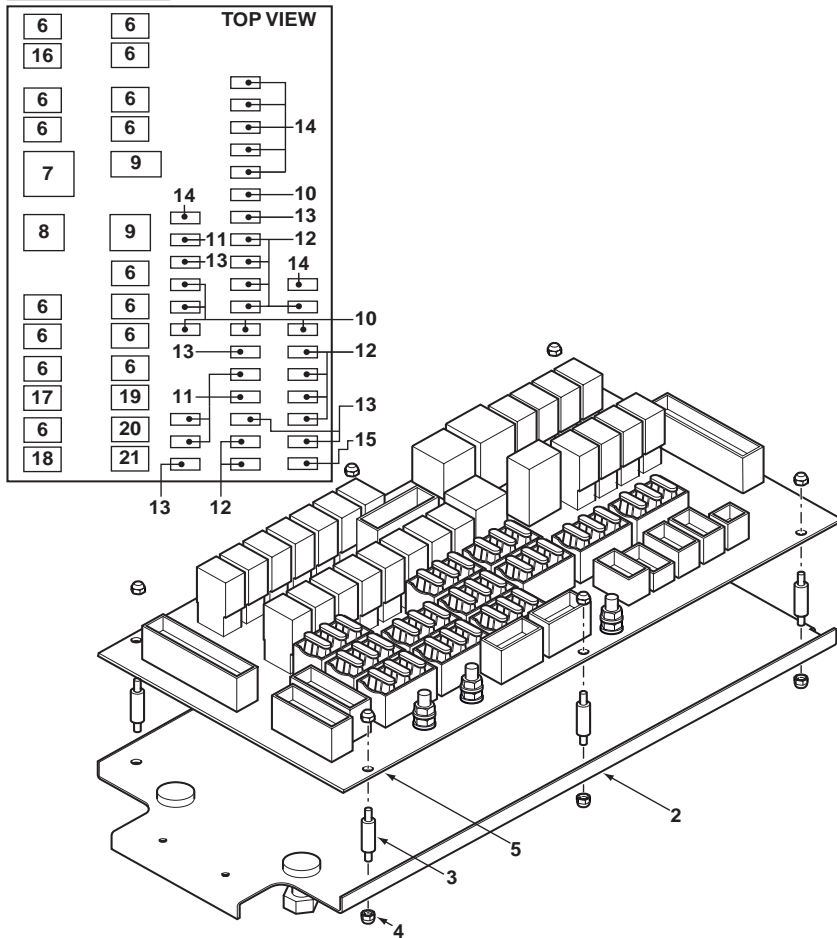

1	6108707M91		56014C01.1 17	1	Fuse/Relay Board	Tableau fus./relais	Tablero fusibles/relés
2		1	Ref.1	1	Plate	Plaque	Placa
3	6102558M1	1		8	Support, Panel	Support de tableau	SopORTE de panel
4	3009074X1	1	M4	16	Nut, Lock	Écrou de blocage	Tuerca de retención
5		1	Ref.1	1	Fuse/Relay Board	Tableau fus./relais	Tablero fusibles/relés
6	6102490M1	5		17	Relay	Relais	Relé
7	6108737M1	5		1	Relay	Relais	Relé
8	6102648M1	5		1	Relay	Relais	Relé
9	6102496M1	5		2	Relay	Relais	Relé
10	6108756M1	5	3 amp	6	Fuse	Fusible	Fusible
11	6108757M1	5	5 amp	6	Fuse	Fusible	Fusible
12	6108754M1	5	7,5 amp	11	Fuse	Fusible	Fusible
13	3523568M1	5	10A	6	Fuse	Fusible	Fusible
14	3523569M1	5	15A	7	Fuse	Fusible	Fusible
15	3523571M1	5	25A	1	Fuse	Fusible	Fusible
16	6102490M1	5	"Hose Burst"	1	Relay	Relais	Relé
17	6102490M1	5	"Loader Q/Attach"	1	Relay	Relais	Relé
18	6102490M1	5	"Digger Q/Attach"	1	Relay	Relais	Relé
19	6102490M1	5	"4WD"	1	Relay	Relais	Relé
20	6102490M1	5	"Ride Control"	1	Relay	Relais	Relé
21	6102490M1	5	"Hose Burst"	1	Relay	Relais	Relé



820 860
TX760B TX860B
TX870B

802 804 810 812 814 816 822 824 832

56014C03.1

6199042M3

1

Jan-06

Side Console
Console Latérale
Consola lateral

Fuse & Relay Board
Tableau de Fusibles & Relais
Tablero de fusibles y relés

C-56015-03.1-A

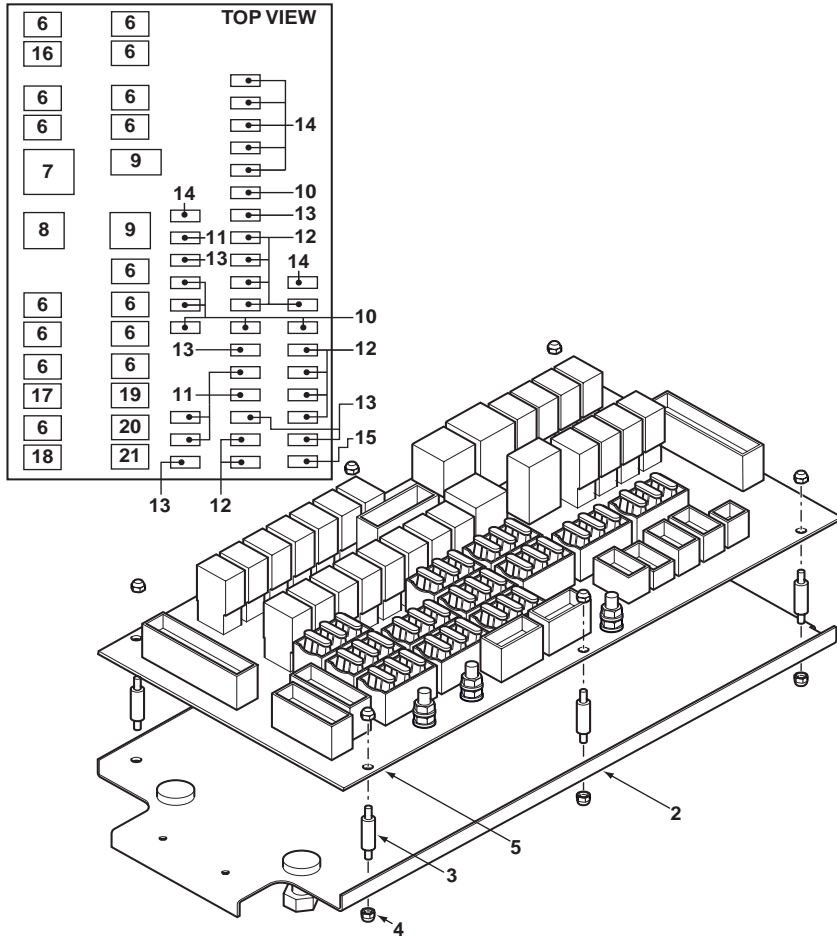

1	6108707M91		56015C01.1 17	1	Fuse/Relay Board	Tableau fus./relais	Tablero fusibles/relés
2		1	Ref.1	1	Plate	Plaque	Placa
3	6102558M1	1		8	Support, Panel	Support de tableau	SopORTE de panel
4	3009074X1	1	M4	16	Nut, Lock	Écrou de blocage	Tuerca de retención
5		1	Ref.1	1	Fuse/Relay Board	Tableau fus./relais	Tablero fusibles/relés
6	6102490M1	5		17	Relay	Relais	Relé
7	6108737M1	5		1	Relay	Relais	Relé
8	6102648M1	5		1	Relay	Relais	Relé
9	6102496M1	5		2	Relay	Relais	Relé
10	6108756M1	5	3 amp	6	Fuse	Fusible	Fusible
11	6108757M1	5	5 amp	6	Fuse	Fusible	Fusible
12	6108754M1	5	7,5 amp	11	Fuse	Fusible	Fusible
13	3523568M1	5	10A	6	Fuse	Fusible	Fusible
14	3523569M1	5	15A	7	Fuse	Fusible	Fusible
15	3523571M1	5	25A	1	Fuse	Fusible	Fusible
16	6102490M1	5	"Hose Burst"	1	Relay	Relais	Relé
17	6102490M1	5	"Loader Q/Attach"	1	Relay	Relais	Relé
18	6102490M1	5	"Digger Q/Attach"	1	Relay	Relais	Relé
19	6102490M1	5	"4WD"	1	Relay	Relais	Relé
20	6102490M1	5	"Ride Control"	1	Relay	Relais	Relé
21	6102490M1	5	"Hose Burst"	1	Relay	Relais	Relé



820
TX760B

806 808 834

56015C03.1

6199042M3

1

Jan-06

Side Console
Console Latérale
Consola lateral

Instrument Panel
Tableau de Bord
Tablero de instrumentos

Switchpack
Ensemble Aiguille
Paquete de cambio

C-56010-02.1-A

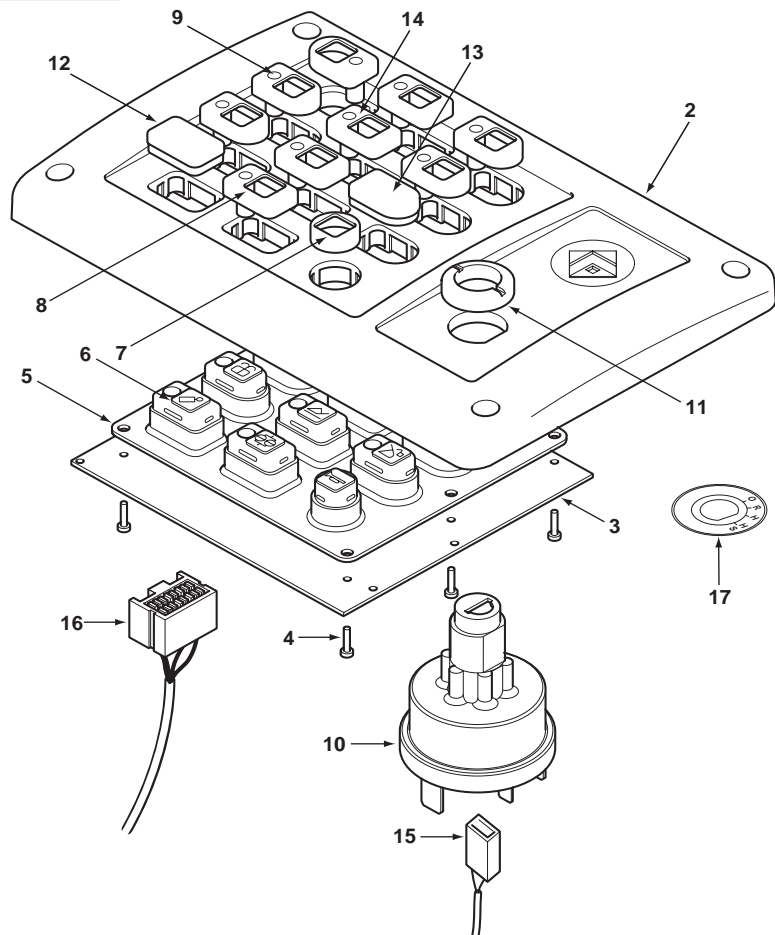

1	6109511M91	56010C01.1 23	1	Switchpack	Paquet de commut.	Paquete de cambio
2		1 Ref. 1	1	Cover	Cache	Tapa
3		1 Ref. 1	1	Switch Assy	Ensemble commutat.	Conmutador, Conj.
4		1 Ref. 1	10	Screw	Vis	Tornillo
5		1 Ref. 1	1	Sheet	Tôle	Chapa
6		1 Ref. 1	1	Decal	Adhésif	Adhesivo
7	6101801M1	1	1	Button	Bouton	Botón
8	6101796M91	1	3	Button	Bouton	Botón
9	6101777M91	1	5	Cover	Cache	Tapa
10	6101809M91	1	1	Switch, Ignition	Commutat. Démarrage	Conmutador, Arranq.
11	6101930M1	1	1	Bezel	Monture	Bisel
12	6101788M1	1	1	Button	Bouton	Botón
13	6101778M1	1	1	Cover	Cache	Tapa
14	6102603M91	1	1	Button	Bouton	Botón
15	6110158M91		1	Harness Assy	Ensemble de faisceau	Haz, Conj.
16	6102300M91		1	Harness Assy	Ensemble de faisceau	Haz, Conj.
17	6110250M1		1	Decal	Adhésif	Adhesivo



820 860 880
TX760B TX860B
TX870B

805 807 817 825 833 841 843 845 851 853 855

56010C02.1

6199042M3

1

Jan-06

Side Console
Console Latérale
Consola lateral

Instrument Panel
Tableau de Bord
Tablero de instrumentos

Switchpack
Ensemble Aiguille
Paquete de cambio

C-56011-02.1-A

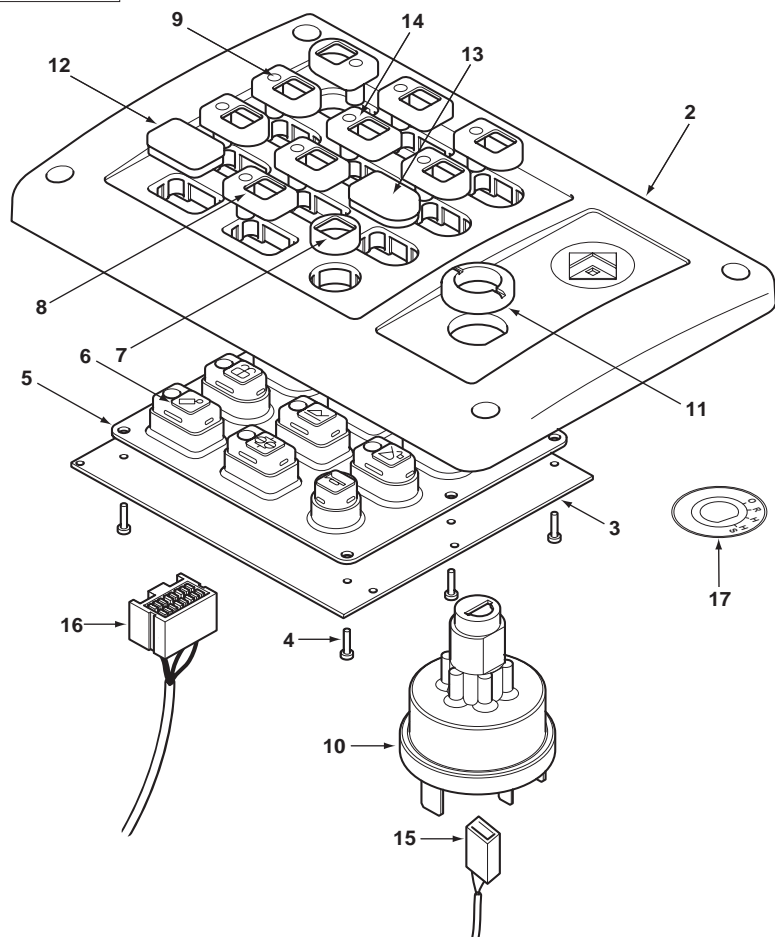

1	6109509M93		56011C01.1 23	1	Switchpack	Paquet de commut.	Paquete de cambio
2		1	Ref. 1	1	Cover	Cache	Tapa
3		1	Ref. 1	1	Switch Assy	Ensemble commutat.	Conmutador, Conj.
4		1	Ref. 1	10	Screw	Vis	Tornillo
5		1	Ref. 1	1	Sheet	Tôle	Chapa
6		1	Ref. 1	1	Decal	Adhésif	Adhesivo
7	6101801M1	1		1	Button	Bouton	Botón
8	6101796M91	1		3	Button	Bouton	Botón
9	6101777M91	1	Switch	5	Cover	Cache	Tapa
10	6101809M91	1		1	Switch, Ignition	Commutat. Démarrage	Conmutador, Arranq.
11	6101930M1	1		1	Bezel	Monture	Bisel
12	6101788M1	1		1	Button	Bouton	Botón
13	6101778M1	1		1	Cover	Cache	Tapa
14	6102603M91	1		1	Button	Bouton	Botón
15	6110158M91			1	Harness Assy	Ensemble de faisceau	Haz, Conj.
16	6102300M91			1	Harness Assy	Ensemble de faisceau	Haz, Conj.
17	6110250M1			1	Decal	Adhésif	Adhesivo



820 860 880
TX760B TX860B
TX870B

801 803 809 811 813 815 821 823 831 841 843 851 853

56011C02.1

6199042M3

1

Jan-06

Side Console
Console Latérale
Consola lateral

Instrument Panel
Tableau de Bord
Tablero de instrumentos

Switchpack
Ensemble Aiguille
Paquete de cambio

C-56012-02.1-A

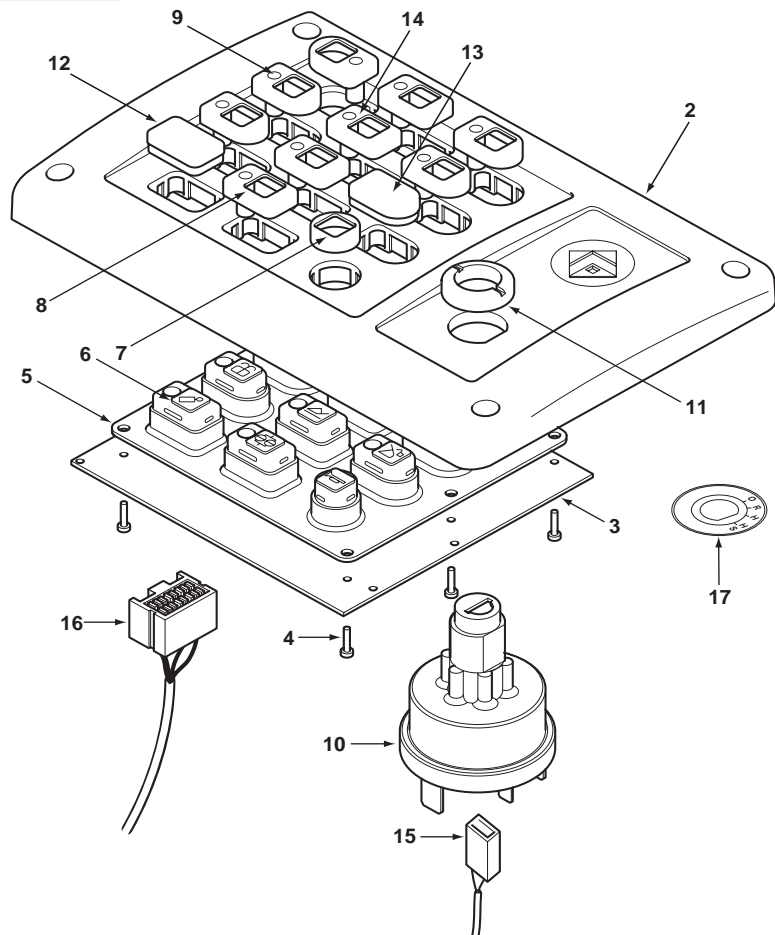

1	6109511M91	56012C01.1 23	1	Switchpack	Paquet de commut.	Paquete de cambio
2		1 Ref. 1	1	Cover	Cache	Tapa
3		1 Ref. 1	1	Switch Assy	Ensemble commutat.	Conmutador, Conj.
4		1 Ref. 1	10	Screw	Vis	Tornillo
5		1 Ref. 1	1	Sheet	Tôle	Chapa
6		1 Ref. 1	1	Decal	Adhésif	Adhesivo
7	6101801M1		1	Button	Bouton	Botón
8	6101796M91		3	Button	Bouton	Botón
9	6101777M91	Switch	5	Cover	Cache	Tapa
10	6101809M91		1	Switch, Ignition	Commutat. Démarrage	Conmutador, Arranq.
11	6101930M1		1	Bezel	Monture	Bisel
12	6101788M1		1	Button	Bouton	Botón
13	6101778M1		1	Cover	Cache	Tapa
14	6102603M91		1	Button	Bouton	Botón
15	6110158M91		1	Harness Assy	Ensemble de faisceau	Haz, Conj.
16	6102300M91		1	Harness Assy	Ensemble de faisceau	Haz, Conj.
17	6110250M1		1	Decal	Adhésif	Adhesivo



880 970 980
TX860B TX870B

845 851 853 855 921 931

56012C02.1

6199042M3

1

Jan-06

Side Console
Console Latérale
Consola lateral

Instrument Panel
Tableau de Bord
Tablero de instrumentos

Switchpack
Ensemble Aiguille
Paquete de cambio

C-56013-02.1-A

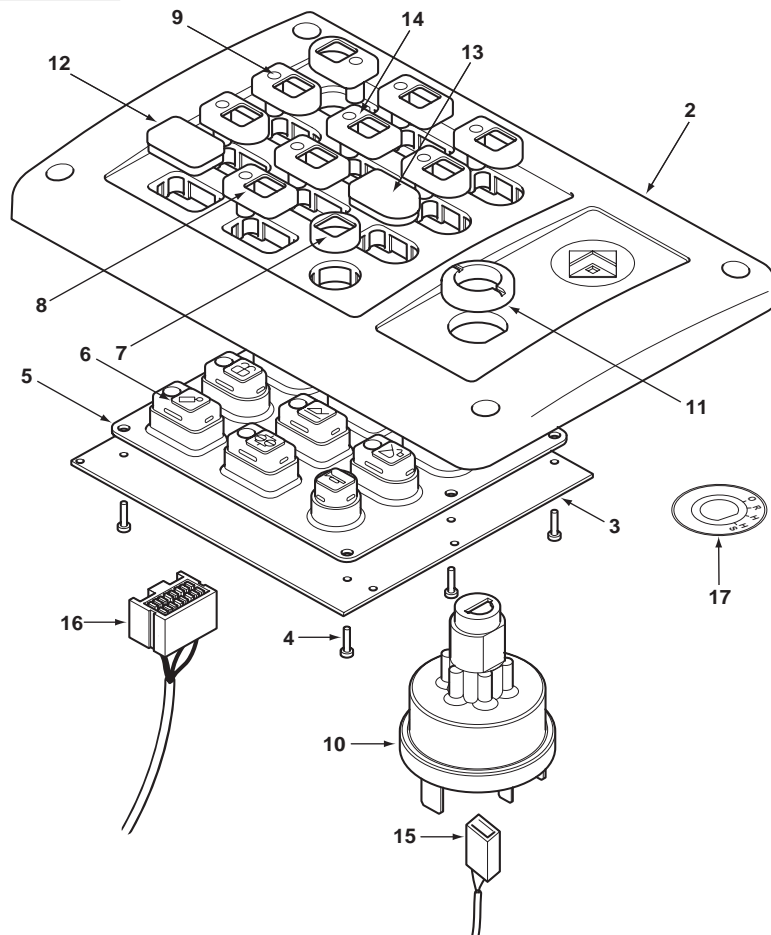

1	6109509M93		56013C01.1 23	1	Switchpack	Paquet de commut.	Paquete de cambio
2		1	Ref. 1	1	Cover	Cache	Tapa
3		1	Ref. 1	1	Switch Assy	Ensemble commutat.	Conmutador, Conj.
4		1	Ref. 1	10	Screw	Vis	Tornillo
5		1	Ref. 1	1	Sheet	Tôle	Chapa
6		1	Ref. 1	1	Decal	Adhésif	Adhesivo
7	6101801M1	1		1	Button	Bouton	Botón
8	6101796M91	1		3	Button	Bouton	Botón
9	6101777M91	1	Switch	5	Cover	Cache	Tapa
10	6101809M91	1		1	Switch, Ignition	Commutat. Démarrage	Conmutador, Arranq.
11	6101930M1	1		1	Bezel	Monture	Bisel
12	6101788M1	1		1	Button	Bouton	Botón
13	6101778M1	1		1	Cover	Cache	Tapa
14	6102603M91	1		1	Button	Bouton	Botón
15	6110158M91			1	Harness Assy	Ensemble de faisceau	Haz, Conj.
16	6102300M91			1	Harness Assy	Ensemble de faisceau	Haz, Conj.
17	6110250M1			1	Decal	Adhésif	Adhesivo



880 970 980
TX860B TX870B
TX970B

851 853 922 923 932

56013C02.1

6199042M3

1

Jan-06

Side Console
Console Latérale
Consola lateral

Instrument Panel
Tableau de Bord
Tablero de instrumentos

Rocker Switch
Commutateur de Culbuteur
Interruptor de eje de balancín

C-56014-02.1-A

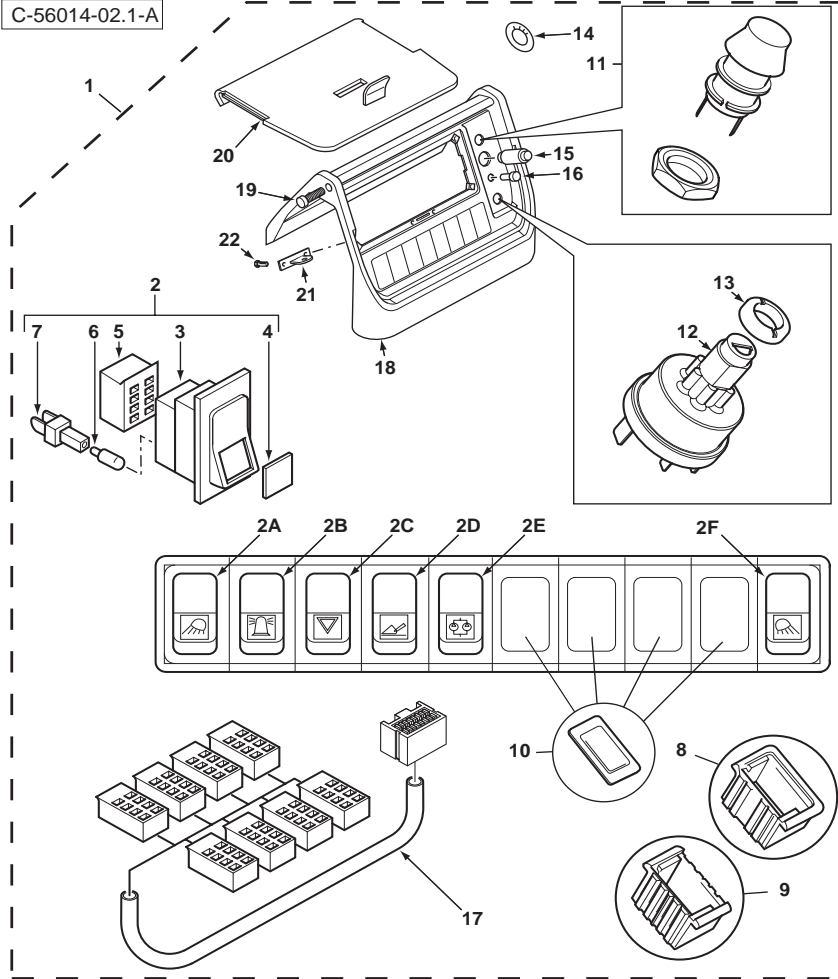

1	6110294M91		Continued	1	Console	Console	Consola
2A	3521578M92	1	Front Work Light	1	Switch Assy	Ensemble commutat.	Conmutador, Conj.
3A	3522477M92	2A		1	Switch	Contacteur	Contactar
4A	3521589M1	2A		1	Symbol	Symbole	Símbolo
2B	3521580M92	1	Beacon	1	Switch, Rocker	Interrupteur	Interruptor
3B	3522477M92	2B		1	Switch	Contacteur	Contactar
4B	1472072M1	2B		1	Symbol	Symbole	Símbolo
2C	3521588M91	1	Hazard	1	Switch Assy	Ensemble commutat.	Conmutador, Conj.
3C	3522480M91	2C		1	Switch	Contacteur	Contactar
4C	3522472M1	2C		1	Symbol	Symbole	Símbolo
2D	3519961M91	1	RTD	1	Switch Assy	Ensemble commutat.	Conmutador, Conj.
3D	3522477M92	2D		1	Switch	Contacteur	Contactar
4D	3519960M1	2D		1	Symbol	Symbole	Símbolo
2E	6107883M91	1	Pump Dump	1	Switch Assy	Ensemble commutat.	Conmutador, Conj.
3E	3522477M92	2E		1	Switch	Contacteur	Contactar
4E	6107882M1	2E		1	Symbol	Symbole	Símbolo
2F	3521581M92	1	Rear Work Light	1	Switch Assy	Ensemble commutat.	Conmutador, Conj.
3F	3522477M92	2F		1	Switch	Contacteur	Contactar
4F	3521590M1	2F		1	Symbol	Symbole	Símbolo
5		2	➡ Ref. 2	4	Housing	Carter	Cárter
6	3523562M1	2	12V 1.2W	4	Bulb	Lampe	Lámpara
7		2	➡ Ref. 2	1	Holder	Porte-injecteur	Retén
8	3516004M1	1		2	Surround	Ceinture	Envolvente
9	3516003M1	1		8	Surround	Ceinture	Envolvente
10	1469751M1	1		4	Cover	Cache	Tapa
11	3516093M91	1		1	Button	Bouton	Botón
12	6101809M91	1		1	Switch, Ignition	Commutat. Démarrage	Conmutador, Arranq.
13	6101930M1	1		1	Bezel	Monture	Bisel
14	6110250M1	1		1	Decal	Adhésif	Adhesivo
15	3517053M91	1		1	Cigar Lighter	Allume-cigares	Encendedor de cig.
16	1473135M1	1		1	Plug	Bouchon	Tapón
17	6108775M93	1		1	Harness Assy	Ensemble de faisceau	Haz, Conj.
18	6108186M2	1	● 56014C01.1 27	1	Panel, Instrument	Tableau de bord	Tablero instrumentos
19	6108521M1	1		2	Pin	Axe	Pasador
20	6108520M92	1		1	Cover Assy	Ensemble de couvercle	Tapa, Conj.
21	6108533M92	1		1	Plate, Locking	Plaque d'arrêt	Placa de bloqueo
22	3512552M1	1	M5 x 12	2	Screw	Vis	Tornillo



820 860
TX760B TX860B
TX870B

802 804 810 812 814 816 822 824 832

56014C02.1

6199042M3

1

Jan-06

Side Console
Console Latérale
Consola lateral

Instrument Panel
Tableau de Bord
Tablero de instrumentos

Rocker Switch
Commutateur de Culbuteur
Interruptor de eje de balancín

C-56015-02.1-A

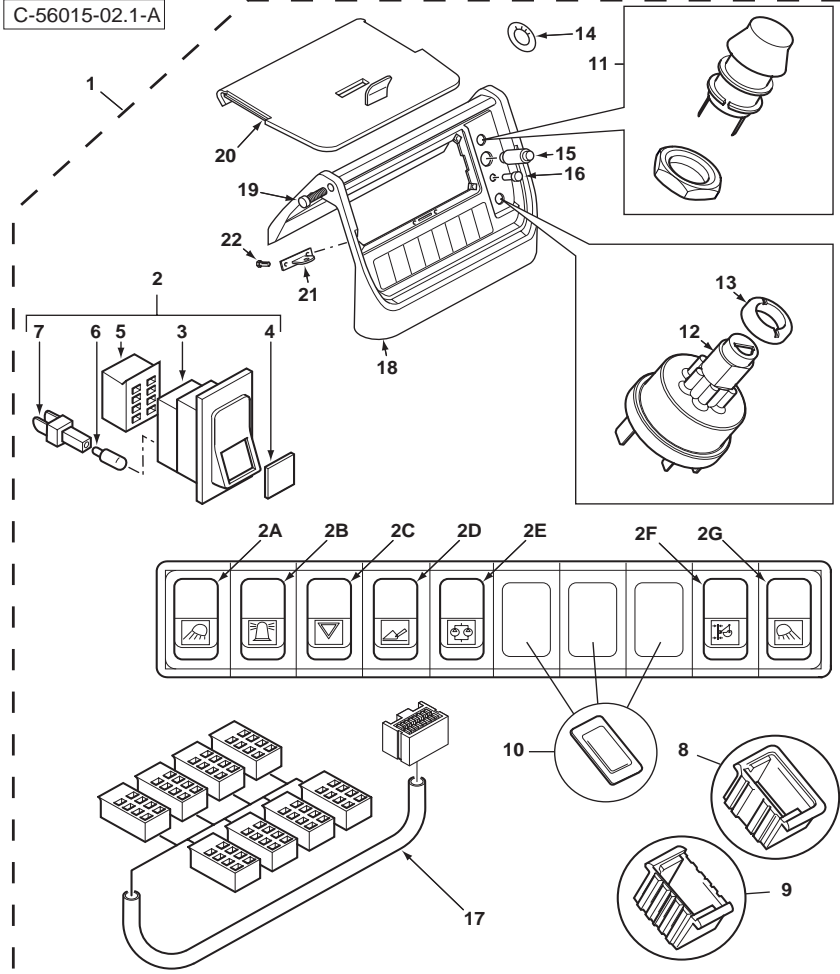

1	6110295M91		Continued	1	Console	Console	Consola
2A	3521578M92	1	Front Work Light	1	Switch Assy	Ensemble commutat.	Conmutador, Conj.
3A	3522477M92	2A		1	Switch	Contacteur	Contactar
4A	3521589M1	2A		1	Symbol	Symbole	Símbolo
2B	3521580M92	1	Beacon	1	Switch, Rocker	Interrupteur	Interruptor
3B	3522477M92	2B		1	Switch	Contacteur	Contactar
4B	1472072M1	2B		1	Symbol	Symbole	Símbolo
2C	3521588M91	1	Hazard	1	Switch Assy	Ensemble commutat.	Conmutador, Conj.
3C	3522480M91	2C		1	Switch	Contacteur	Contactar
4C	3522472M1	2C		1	Symbol	Symbole	Símbolo
2D	3519961M91	1	RTD	1	Switch Assy	Ensemble commutat.	Conmutador, Conj.
3D	3522477M92	2D		1	Switch	Contacteur	Contactar
4D	3519960M1	2D		1	Symbol	Symbole	Símbolo
2E	6107883M91	1	Pump Dump	1	Switch Assy	Ensemble commutat.	Conmutador, Conj.
3E	3522477M92	2E		1	Switch	Contacteur	Contactar
4E	6107882M1	2E		1	Symbol	Symbole	Símbolo
2F	3521584M92	1	Side Shift Clamp	1	Switch Assy	Ensemble commutat.	Conmutador, Conj.
3F	3522477M92	2F		1	Switch	Contacteur	Contactar
4F	3522473M1	2F		1	Symbol	Symbole	Símbolo
2G	3521581M92	1	Rear Work Light	1	Switch Assy	Ensemble commutat.	Conmutador, Conj.
3G	3522477M92	2G		1	Switch	Contacteur	Contactar
4G	3521590M1	2G		1	Symbol	Symbole	Símbolo
5		2	➡ Ref. 2	4	Housing	Carter	Cárter
6	3523562M1	2	12V 1.2W	4	Bulb	Lampe	Lámpara
7		2	➡ Ref. 2	1	Holder	Porte-injecteur	Retén
8	3516004M1	1		2	Surround	Ceinture	Envolvente
9	3516003M1	1		8	Surround	Ceinture	Envolvente
10	1469751M1	1		3	Cover	Cache	Tapa
11	3516093M91	1		1	Button	Bouton	Botón
12	6101809M91	1		1	Switch, Ignition	Commutat. Démarrage	Conmutador, Arranq.
13	6101930M1	1		1	Bezel	Monture	Bisel
14	6110250M1	1		1	Decal	Adhésif	Adhesivo
15	3517053M91	1		1	Cigar Lighter	Allume-cigares	Encendedor de cig.
16	1473135M1	1		1	Plug	Bouchon	Tapón
17	6108775M93	1		1	Harness Assy	Ensemble de faisceau	Haz, Conj.
18	6108186M2	1	● 56015C01.1 27	1	Panel, Instrument	Tableau de bord	Tablero instrumentos
19	6108521M1	1		2	Pin	Axe	Pasador
20	6108520M92	1		1	Cover Assy	Ensemble de couvercle	Tapa, Conj.
21	6108533M92	1		1	Plate, Locking	Plaque d'arrêt	Placa de bloqueo
22	3512552M1	1	M5 x 12	2	Screw	Vis	Tornillo



820
TX760B

806 808 834

56015C02.1

6199042M3

1

Jan-06

J - Electrics • Équipement électrique • Sistema eléctrico

Battery - Dual.....	58002C01.1	Batterie - Double	Bateria - Doble
Battery - Dual.....	58006C01.1	Batterie - Double	Bateria - Doble
Battery - Single.....	58001C01.1	Batterie - Simple	Bateria - Sencilla
Battery - Single.....	58005C01.1	Batterie - Simple	Bateria - Sencilla
Chassis Electrics.....	57010C01.1	Circuit Électrique - Châssis	Circuito eléctrico chasis
Chassis Electrics.....	57011C01.1	Circuit Électrique - Châssis	Circuito eléctrico chasis
Chassis Electrics.....	57013C01.1	Circuit Électrique - Châssis	Circuito eléctrico chasis
Chassis Electrics.....	57014C01.1	Circuit Électrique - Châssis	Circuito eléctrico chasis
Front Lighting - Headlights.....	60001C01.1	Feux Avant - Phares	Luces delanteras - Faros
Front Lighting - Headlights.....	60002C01.1	Feux Avant - Phares	Luces delanteras - Faros
Rear Lighting - Centremount.....	59002C01.1	Feux Arrière - Montage de Pelle Central	Luces traseras - Excavadora de montaje central
Rear Lighting - ROPS.....	59003C01.1	Feux Arrière - ROPS	Luces traseras - ROPS
Rear Lighting - ROPS.....	59004C01.1	Feux Arrière - ROPS	Luces traseras - ROPS
Rear Lighting - Sideshift.....	59001C01.1	Feux Arrière - Montage de Pelle Latéral	Luces traseras - Excavadora de montaje horizontal



Battery
Batterie
Batería

Dual
Double
Doble

Up To Serial Number H200 4 2919
Jusqu'au No. H200 4 2919
Hasta el no. H200 4 2919

C-58002-01.1-A

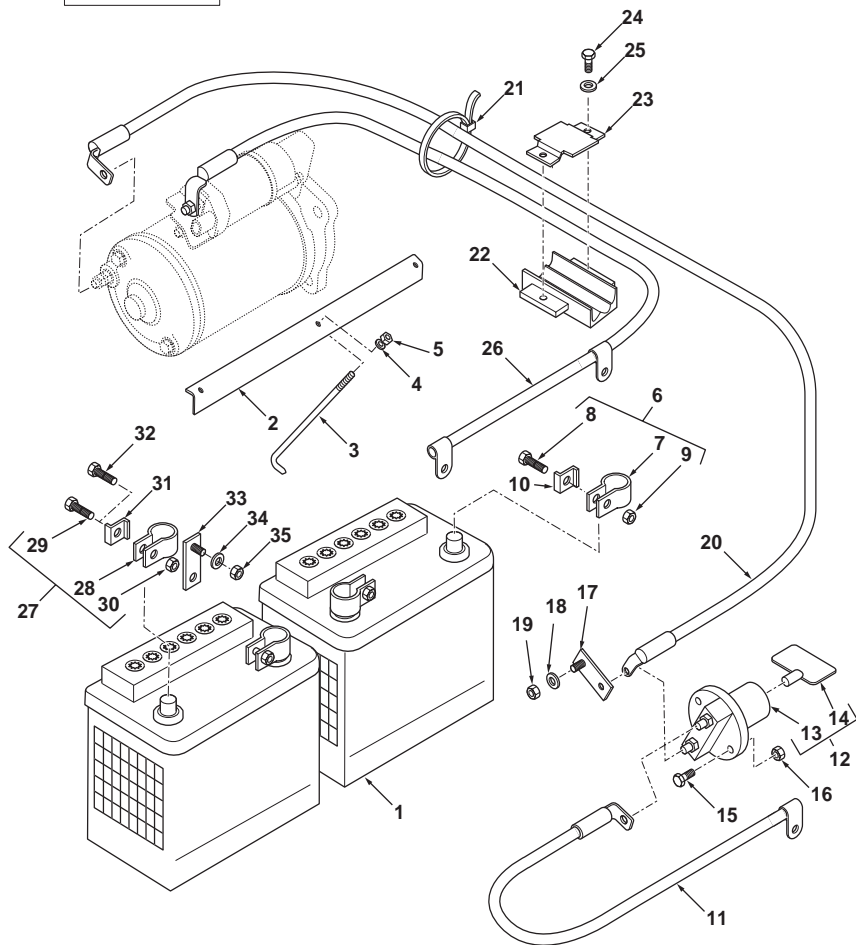

1	3507616M2	(B)	2	Battery	Batterie	Batería
2	6109653M1		1	Angle Plate	Coin	Angulo
3	3520251M1		1	Rod, Truss	Tirant	Tirante
4	390971X1	M6	1	Washer	Rondelle	Arandela
5	1441500X1	M6	1	Nut, Lock	Écrou de blocage	Tuerca de retención
6	1473634M91	-ve	2	Clamp	Collier de serrage	Argolla de cierre
7		6 Ref. 6	1	Clamp	Collier de serrage	Argolla de cierre
8		6 Ref. 6	1	Bolt	Boulon	Perno
9		6 Ref. 6	1	Nut	Écrou	Tuerca
10	6109953M1		2	Retainer	Dispositif de retenue	Fijación
11	6109633M93	-ve	1	Cable Assy	Ensemble de câble	Cable, Conj.
12	6108059M91		1	Isolator	Isolateur	Aislador
13		12 Ref. 8	1	Isolator	Isolateur	Aislador
14	6108791M1	12	1	Key	Clavette	Chaveta
15	339804X1	M6 x 25	2	Screw	Vis	Tornillo
16	1441500X1	M6	2	Nut, Lock	Écrou de blocage	Tuerca de retención
17	6109951M91		1	Connector, Terminal	Cosse	Terminal
18	390972X1	M8	1	Washer	Rondelle	Arandela
19	394367X1	M8	1	Nut, Lock	Écrou de blocage	Tuerca de retención
20	6109634M92	-ve	1	Cable Assy	Ensemble de câble	Cable, Conj.
21	724497M1		5	Tie, Cable	Attache câble	Enlace de Cable
22	6101682M3		1	Clamp	Collier de serrage	Argolla de cierre
23	6101683M3		1	Plate	Plaque	Placa
24	339124X1	M8 x 16	2	Screw	Vis	Tornillo
25	390972X1	M8	2	Washer	Rondelle	Arandela
26	6109631M92	+ve	1	Cable Assy	Ensemble de câble	Cable, Conj.
27	1472733M91	+ve	2	Clamp	Collier de serrage	Argolla de cierre
28		27 Ref. 27	1	Clamp	Collier de serrage	Argolla de cierre
29		27 (A) Ref. 27	1	Bolt	Boulon	Perno
30		27 Ref. 27	1	Nut	Écrou	Tuerca
31	6109953M1		2	Retainer	Dispositif de retenue	Fijación
32	339123X1	Ref. 29 M8 x 20	1	Bolt	Boulon	Perno
33	6109951M91		1	Connector, Terminal	Cosse	Terminal
34	390972X1	M8	1	Washer	Rondelle	Arandela
35	394367X1	M8	1	Nut, Lock	Écrou de blocage	Tuerca de retención

A Not required for this application
Pas utilisé pour cette application
No utilizado en esta aplicación

B Procure locally
Approvisionnement local
Procurar localmente



820 860 880 970 980
TX760B TX860B
TX870B TX970B

801 802 803 804 805 806 807 808 809 810 811 812 813 814 815 816 817 821 822
823 824 825 831 832 833 834 841 842 843 844 845 851 852 853 854 855 921 922
923 931 932

58002C01.1

6199042M3

1

Jan-06

**Battery
Batterie
Batería**

**Dual
Double
Doble**

From Serial Number H200 4 2919
A Partir No. H200 4 2919
Desde el no. H200 4 2919

C-58006-01.1-A

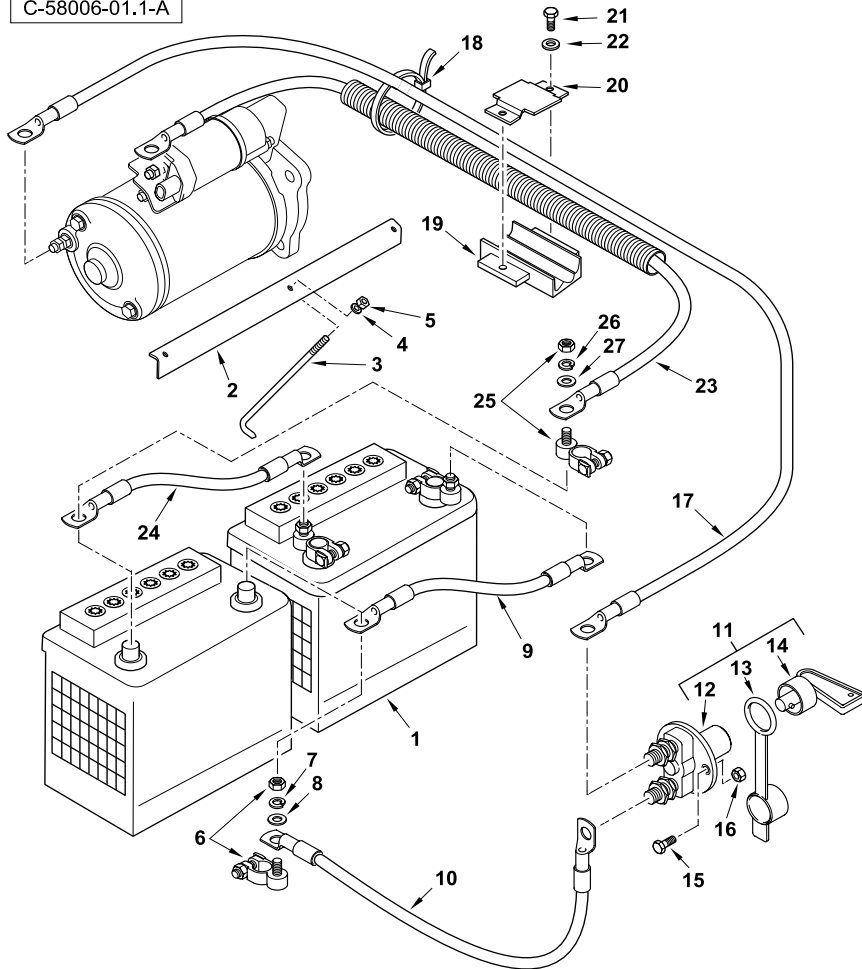

1	3507616M2	(A)	2	Battery	Batterie	Batería
2	6109653M1		1	Angle Plate	Coin	Angulo
3	3520251M1		1	Rod, Truss	Tirant	Tirante
4	390971X1	M6	1	Washer	Rondelle	Arandela
5	1441500X1	M6	1	Nut, Lock	Écrou de blocage	Tuerca de retención
6	6110532M1	Battery -ve	2	Clamp	Collier de serrage	Argolla de cierre
7	339374X1	M8	2	Washer, Lock	Rondelle de blocage	Arandela de freno
8	390972X1	M8	2	Washer	Rondelle	Arandela
9	6110527M1	-ve 275mm	1	Cable	Câble	Cable
10	6110527M1	-ve 275mm	1	Cable	Câble	Cable
11	6110534M91		1	Isolator	Isolateur	Aislador
12		11	1	Isolator	Isolateur	Aislador
13		11 (B)	1	Cap	Chapeau	Sombbrero
14		11 (B)	2	Key	Clavette	Chaveta
15	339804X1	M6 x 25	2	Screw	Vis	Tornillo
16	1441500X1	M6	2	Nut, Lock	Écrou de blocage	Tuerca de retención
17	6110530M1	-ve 2000mm	1	Cable	Câble	Cable
18	724497M1		5	Tie, Cable	Attache câble	Enlace de Cable
19	6101682M3		1	Clamp	Collier de serrage	Argolla de cierre
20	6101683M3		1	Plate	Plaque	Placa
21	339124X1	M8 x 16	2	Screw	Vis	Tornillo
22	390972X1	M8	2	Washer	Rondelle	Arandela
23	6110531M1	+ve 2000mm	1	Cable	Câble	Cable
24	6110528M1	+ve 275mm	1	Cable	Câble	Cable
25	6110533M1	Battery +ve	2	Clamp	Collier de serrage	Argolla de cierre
26	339374X1	M8	2	Washer, Lock	Rondelle de blocage	Arandela de freno
27	390972X1	M8	2	Washer	Rondelle	Arandela

A Procure locally
Approvisionnement local
Procurare localmente

B Part number to be advised
Référence pièce à demander
Indicar número de pieza



820 860 880 970 980
TX760B TX860B
TX870B TX970B

801 802 803 804 805 806 807 808 809 810 811 812 813 814 815 816 817 821 822
823 824 825 831 832 833 834 841 842 843 844 845 851 852 853 854 855 921 922
923 931 932

58006C01.1

6199042M3

1

Jan-06

**Battery
Batterie
Bateria**

**Single
Simple
Sencilla**

Up To Serial Number H200 4 2919
Jusqu'au No. H200 4 2919
Hasta el no. H200 4 2919

C-58001-01.1-A

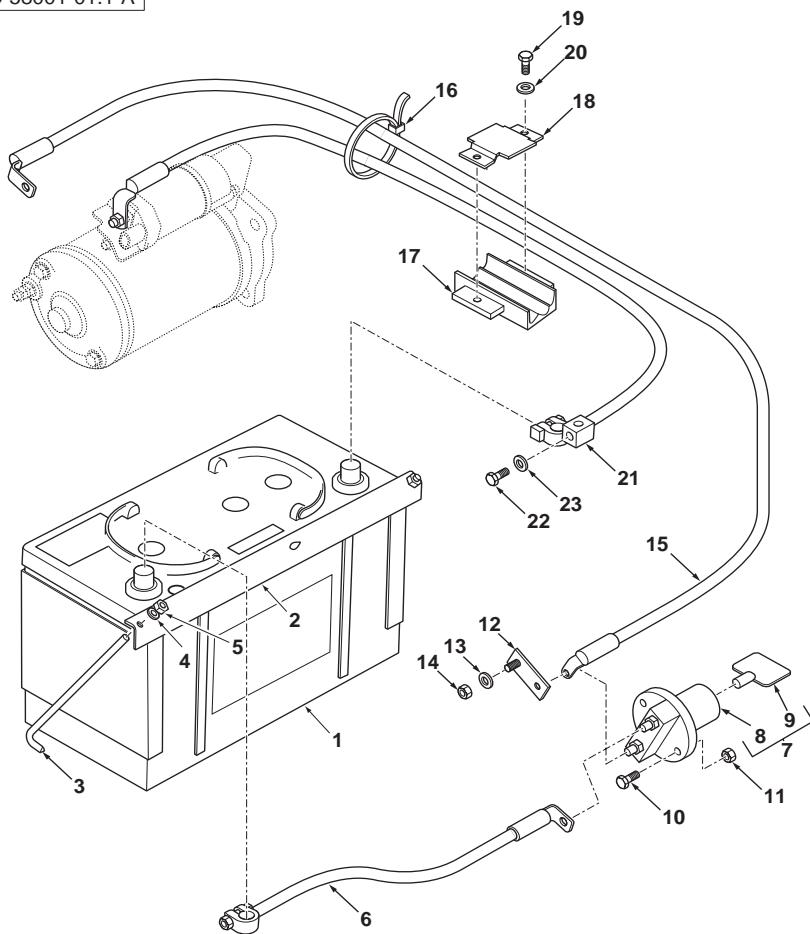

1	3507617M2	(A)	1	Battery	Batterie	Bateria
2	6109653M1		1	Angle Plate	Coin	Angulo
3	3520251M1		2	Rod, Truss	Tirant	Tirante
4	390971X1	M6	2	Washer	Rondelle	Arandela
5	1441500X1	M6	2	Nut, Lock	Écrou de blocage	Tuerca de retención
6	6109630M93	-ve	1	Cable Assy	Ensemble de câble	Cable, Conj.
7	6108059M91		1	Isolator	Isolateur	Aislador
8		7	1	Isolator	Isolateur	Aislador
9	6108791M1	7	1	Key	Clavette	Chaveta
10	339804X1	M6 x 25	2	Screw	Vis	Tornillo
11	1441500X1	M6	2	Nut, Lock	Écrou de blocage	Tuerca de retención
12	6109951M91		1	Connector, Terminal	Cosse	Terminal
13	390972X1	M8	1	Washer	Rondelle	Arandela
14	394367X1	M8	1	Nut, Lock	Écrou de blocage	Tuerca de retención
15	6109634M92	-ve	1	Cable Assy	Ensemble de câble	Cable, Conj.
16	724497M1		5	Tie, Cable	Attache câble	Enlace de Cable
17	6101682M3		1	Clamp	Collier de serrage	Argolla de cierre
18	6101683M3		1	Plate	Plaque	Placa
19	339124X1	M8 x 16	2	Screw	Vis	Tornillo
20	390972X1	M8	2	Washer	Rondelle	Arandela
21	6109615M92	+ ve	1	Cable Assy	Ensemble de câble	Cable, Conj.
22	339124X1	M8 x 16	1	Screw	Vis	Tornillo
23	390972X1	M8	1	Washer	Rondelle	Arandela

A Procure locally
Approvisionnement local
Procurare localmente



820 860 880 970 980
TX760B TX860B
TX870B TX970B

801 802 803 804 805 806 807 808 809 810 811 812 813 814 815 816 817 821 822
823 824 825 831 832 833 834 841 842 843 844 845 851 852 853 854 855 921 922
923 931 932

58001C01.1

6199042M3

1

Jan-06

**Battery
Batterie
Bateria**

**Single
Simple
Sencilla**

From Serial Number H200 4 2919
A Partir No. H200 4 2919
Desde el no. H200 4 2919

C-58005-01.1-A

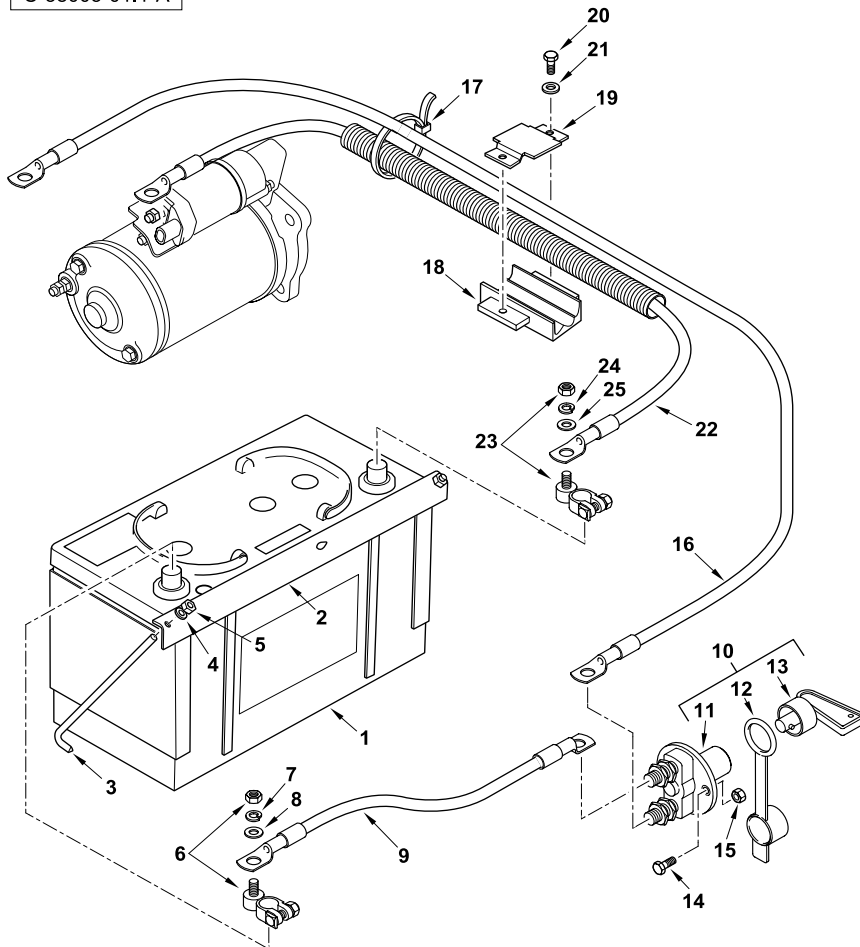

1	3507617M2	(A)	1	Battery	Batterie	Bateria
2	6109653M1		1	Angle Plate	Coin	Angulo
3	3520251M1		2	Rod, Truss	Tirant	Tirante
4	390971X1	M6	2	Washer	Rondelle	Arandela
5	1441500X1	M6	2	Nut, Lock	Écrou de blocage	Tuerca de retención
6	6110532M1	Battery -ve	1	Clamp	Collier de serrage	Argolla de cierre
7	339374X1	M8	1	Washer, Lock	Rondelle de blocage	Arandela de freno
8	390972X1	M8	1	Washer	Rondelle	Arandela
9	6110527M1	-ve 275mm	1	Cable	Câble	Cable
10	6110534M91		1	Isolator	Isolateur	Aislador
11		10	1	Isolator	Isolateur	Aislador
12		10 (B)	1	Cap	Chapeau	Sombbrero
13		10 (B)	2	Key	Clavette	Chaveta
14	339804X1	M6 x 25	2	Screw	Vis	Tornillo
15	1441500X1	M6	2	Nut, Lock	Écrou de blocage	Tuerca de retención
16	6110530M1	-ve 2000mm	1	Cable	Câble	Cable
17	724497M1		5	Tie, Cable	Attache câble	Enlace de Cable
18	6101682M3		1	Clamp	Collier de serrage	Argolla de cierre
19	6101683M3		1	Plate	Plaque	Placa
20	339124X1	M8 x 16	2	Screw	Vis	Tornillo
21	390972X1	M8	2	Washer	Rondelle	Arandela
22	6110531M1	+ve 2000mm	1	Cable	Câble	Cable
23	6110533M1	Battery +ve	1	Clamp	Collier de serrage	Argolla de cierre
24	339374X1	M8	1	Washer, Lock	Rondelle de blocage	Arandela de freno
25	390972X1	M8	1	Washer	Rondelle	Arandela

A Procure locally
Approvisionnement local
Procurare localmente

B Part number to be advised
Référence pièce à demander
Indicar número de pieza



820 860 880 970 980
TX760B TX860B
TX870B TX970B

801 802 803 804 805 806 807 808 809 810 811 812 813 814 815 816 817 821 822
823 824 825 831 832 833 834 841 842 843 844 845 851 852 853 854 855 921 922
923 931 932

58005C01.1

6199042M3

1

Jan-06

Chassis Electric
Circuit Électrique - Châssis
Circuito eléctrico chasis

C-57010-01.1-A

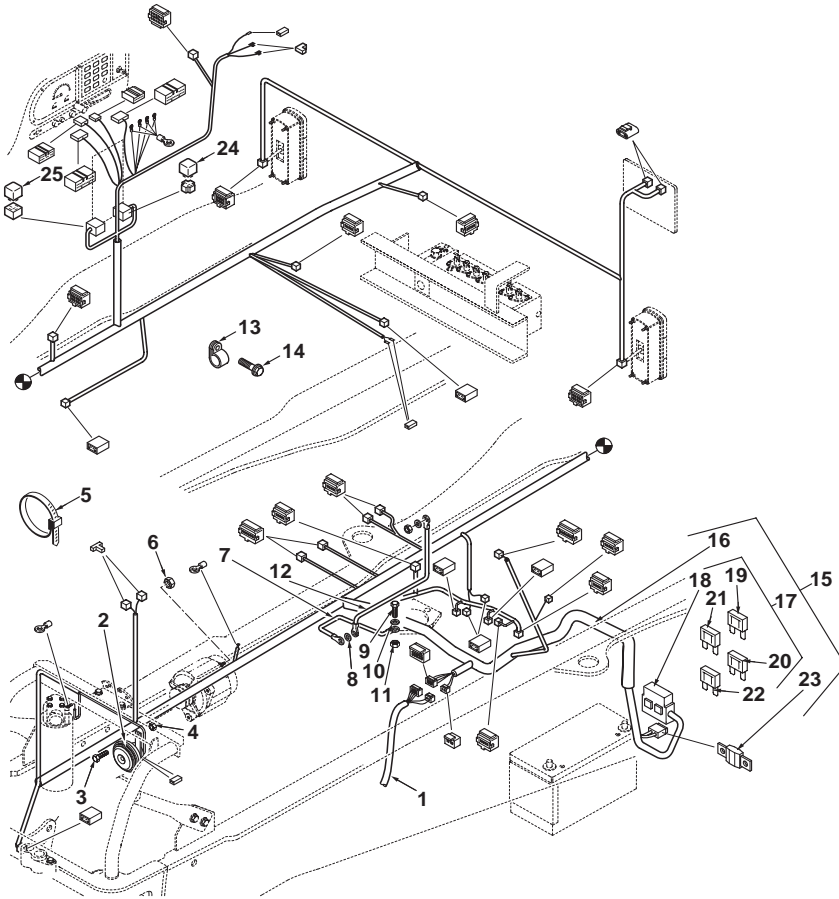

1	6110097M92	Engine	1	Harness Assy	Ensemble de faisceau	Haz, Conj.
2	6108843M1		1	Horn	Avertisseur sonore	Alarma sonora
3	339124X1	M8 x 16	1	Screw	Vis	Tornillo
4	394367X1	M8	1	Nut, Lock	Écrou de blocage	Tuerca de retención
5	1664405M1		X	Tie, Cable	Attache câble	Enlace de Cable
6	339030X1	M6	1	Nut	Écrou	Tuerca
7	6101483M92		1	Earth Strap	Fil de masse	Cable de masa
8	390735X1	M12	1	Washer	Rondelle	Arandela
9	3009508X1	M12 x 40	1	Screw	Vis	Tornillo
10	390735X1	M12	1	Washer	Rondelle	Arandela
11	1440330X1	M12	1	Nut	Écrou	Tuerca
12	6101483M92		1	Earth Strap	Fil de masse	Cable de masa
13	3522812M1		1	Bracket, Clamp	Bride de fixation	Brida de fijación
14	3009205X1	M10 x 20	1	Bolt	Boulon	Perno
15	6110156M92	Chassis	1	Harness Assy	Ensemble de faisceau	Haz, Conj.
16		15	1	Harness	Faisceau	Haz
17		15	1	Box, Fuse	Boîte à fusibles	Caja de fusibles
18		17	1	Box, Fuse	Boîte à fusibles	Caja de fusibles
19	6102646M91	17 80 amp	1	Fuse	Fusible	Fusible
20	6102644M91	17 20 amp	1	Fuse	Fusible	Fusible
21	6102645M91	17 40 amp	1	Fuse	Fusible	Fusible
22	6102646M91	17 80 amp	1	Fuse	Fusible	Fusible
23	6194498M1	15 125A "Orange"	1	Fuse	Fusible	Fusible
24	6110473M1		3	Relay	Relais	Relé
25	6110516M1	Power	2	Relay	Relais	Relé



820 860 880
 TX760B TX860B
 TX870B

801 802 803 804 805 806 807 808 809 810 811 812 813 814 815 816 817 831 832
 833 834 841 842 843 844 845

57010C01.1

6199042M3

1

Jan-06

Chassis Electric
Circuit Électrique - Châssis
Circuito eléctrico chasis

C-57011-01.1-A

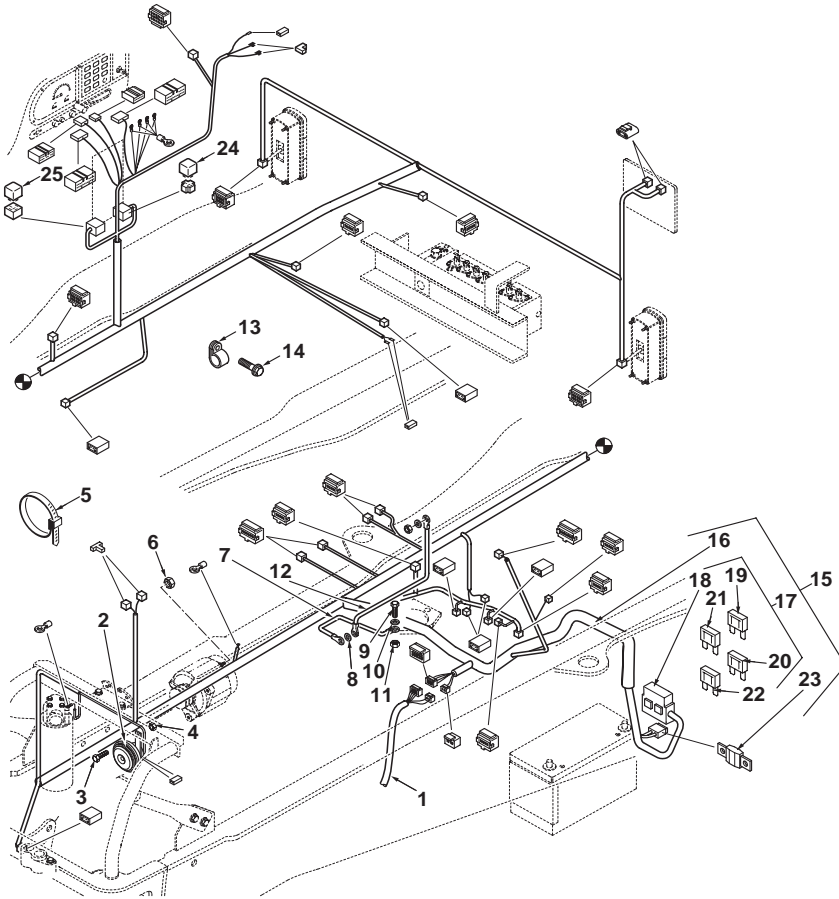

1	6110097M92	Engine	1	Harness Assy	Ensemble de faisceau	Haz, Conj.
2	6108843M1		1	Horn	Avertisseur sonore	Alarma sonora
3	339124X1	M8 x 16	1	Screw	Vis	Tornillo
4	394367X1	M8	1	Nut, Lock	Écrou de blocage	Tuerca de retención
5	1664405M1		X	Tie, Cable	Attache câble	Enlace de Cable
6	339030X1	M6	1	Nut	Écrou	Tuerca
7	6101483M92		1	Earth Strap	Fil de masse	Cable de masa
8	390735X1	M12	1	Washer	Rondelle	Arandela
9	3009508X1	M12 x 40	1	Screw	Vis	Tornillo
10	390735X1	M12	1	Washer	Rondelle	Arandela
11	1440330X1	M12	1	Nut	Écrou	Tuerca
12	6101483M92		1	Earth Strap	Fil de masse	Cable de masa
13	3522812M1		1	Bracket, Clamp	Bride de fixation	Brida de fijación
14	3009205X1	M10 x 20	1	Bolt	Boulon	Perno
15	6110157M91	Chassis	1	Harness Assy	Ensemble de faisceau	Haz, Conj.
16		15	1	Harness	Faisceau	Haz
17		15	1	Box, Fuse	Boîte à fusibles	Caja de fusibles
18		17	1	Box, Fuse	Boîte à fusibles	Caja de fusibles
19	6102646M91	17 80 amp	1	Fuse	Fusible	Fusible
20	6102644M91	17 20 amp	1	Fuse	Fusible	Fusible
21	6102645M91	17 40 amp	1	Fuse	Fusible	Fusible
22	6102646M91	17 80 amp	1	Fuse	Fusible	Fusible
23	6194498M1	15 125A "Orange"	1	Fuse	Fusible	Fusible
24	6110473M1		3	Relay	Relais	Relé
25	6110516M1	Power	2	Relay	Relais	Relé



860 880
 TX860B TX870B

821 822 823 824 825 851 852 853 854 855

57011C01.1

6199042M3

1

Jan-06

Chassis Electric
Circuit Électrique - Châssis
Circuito eléctrico chasis

C-57013-01.1-A

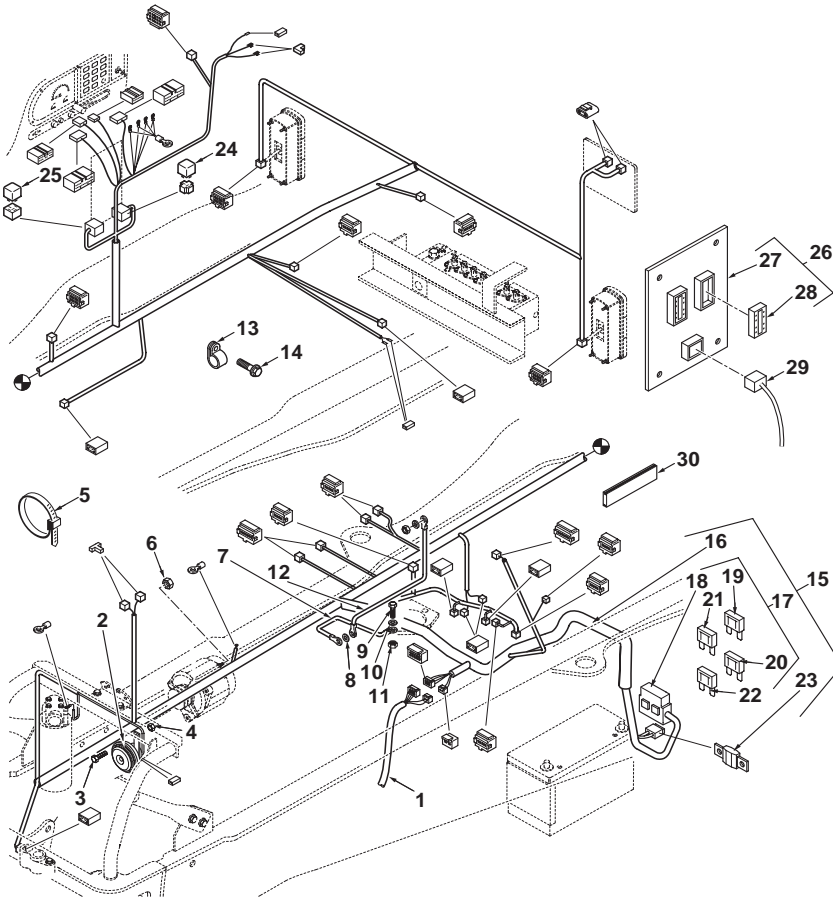

1	6110097M92	Engine	1	Harness Assy	Ensemble de faisceau	Haz, Conj.
2	6108843M1		1	Horn	Avertisseur sonore	Alarma sonora
3	339124X1	M8 x 16	1	Screw	Vis	Tornillo
4	394367X1	M8	1	Nut, Lock	Écrou de blocage	Tuerca de retención
5	1664405M1		X	Tie, Cable	Attache câble	Enlace de Cable
6	339030X1	M6	1	Nut	Écrou	Tuerca
7	6101483M92		1	Earth Strap	Fil de masse	Cable de masa
8	390735X1	M12	1	Washer	Rondelle	Arandela
9	3009508X1	M12 x 40	1	Screw	Vis	Tornillo
10	390735X1	M12	1	Washer	Rondelle	Arandela
11	1440330X1	M12	1	Nut	Écrou	Tuerca
12	6101483M92		1	Earth Strap	Fil de masse	Cable de masa
13	3522812M1		1	Bracket, Clamp	Bride de fixation	Brida de fijación
14	3009205X1	M10 x 20	1	Bolt	Boulon	Perno
15	6110157M91	Chassis	1	Harness Assy	Ensemble de faisceau	Haz, Conj.
16		15	1	Harness	Faisceau	Haz
17		15	1	Box, Fuse	Boîte à fusibles	Caja de fusibles
18		17	1	Box, Fuse	Boîte à fusibles	Caja de fusibles
19	6102646M91	17 80 amp	1	Fuse	Fusible	Fusible
20	6102644M91	17 20 amp	1	Fuse	Fusible	Fusible
21	6102645M91	17 40 amp	1	Fuse	Fusible	Fusible
22	6102646M91	17 80 amp	1	Fuse	Fusible	Fusible
23	6194498M1	15 125A "Orange"	1	Fuse	Fusible	Fusible
24	6110473M1	Mini	3	Relay	Relais	Relé
25	6110516M1	Power	2	Relay	Relais	Relé
26	6109852M91		1	Fuse/Relay Board	Tableau fus./relais	Tablero fusibles/relés
27		26	1	Fuse/Relay Board	Tableau fus./relais	Tablero fusibles/relés
28	6110153M1	26	2	Relay	Relais	Relé
29	6109813M92	→ 21-04-2004 4WS/ Crab	1	Harness Assy	Ensemble de faisceau	Haz, Conj.
29	6110503M91	↳ 21-04-2004 4WS/ Crab	1	Harness Assy	Ensemble de faisceau	Haz, Conj.
30	6110162M91		2	Strip, Sealing	Bande d'étanchéité	Banda estanqueidad



970 980
TX970B

921 922 923 931 932

57013C01.1

6199042M3

1

Jan-06

Chassis Electric
Circuit Électrique - Châssis
Circuito eléctrico chasis

Synchro Shuttle - Carraro
 Synchro Shuttle - Carraro
 Synchro Shuttle - Carraro

C-57014-01.1-A

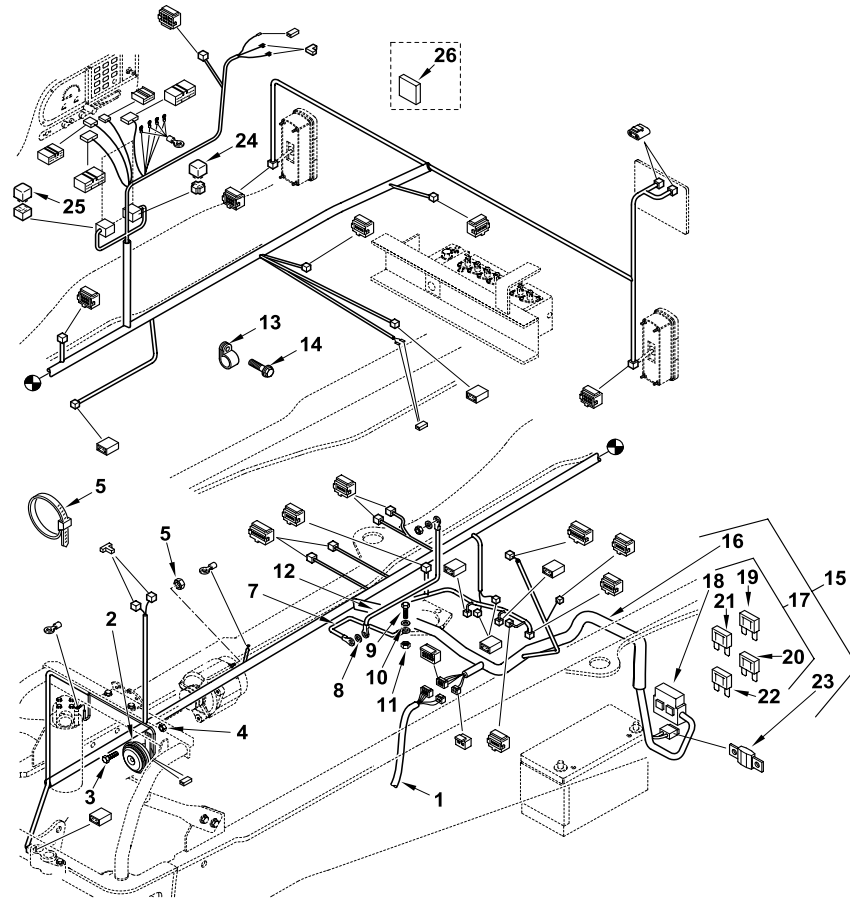

1	6110097M92	Engine	1	Harness Assy	Ensemble de faisceau	Haz, Conj.
2	6108843M1		1	Horn	Avertisseur sonore	Alarma sonora
3	339124X1	M8 x 16	1	Screw	Vis	Tornillo
4	394367X1	M8	1	Nut, Lock	Écrou de blocage	Tuerca de retención
5	1664405M1		7	Tie, Cable	Attache câble	Enlace de Cable
6	339030X1	M6	1	Nut	Écrou	Tuerca
7	6101483M92		1	Earth Strap	Fil de masse	Cable de masa
8	390735X1	M12	1	Washer	Rondelle	Arandela
9	3009508X1	M12 x 40	1	Screw	Vis	Tornillo
10	390735X1	M12	1	Washer	Rondelle	Arandela
11	1440330X1	M12	2	Nut	Écrou	Tuerca
12	6101483M92		1	Earth Strap	Fil de masse	Cable de masa
13	3522812M1		1	Bracket, Clamp	Bride de fixation	Brida de fijación
14	3009205X1	M10 x 20	1	Bolt	Boulon	Perno
15	6110570M91	Chassis	1	Harness Assy	Ensemble de faisceau	Haz, Conj.
16		15	1	Harness	Faisceau	Haz
17		15	1	Box, Fuse	Boîte à fusibles	Caja de fusibles
18		17	1	Box, Fuse	Boîte à fusibles	Caja de fusibles
19	6102646M91	17 80 amp	1	Fuse	Fusible	Fusible
20	6102644M91	17 20 amp	1	Fuse	Fusible	Fusible
21	6102645M91	17 40 amp	1	Fuse	Fusible	Fusible
22	6102646M91	17 80 amp	1	Fuse	Fusible	Fusible
23	6194498M1	15 125A "Orange"	1	Fuse	Fusible	Fusible
24	6110473M1		4	Relay	Relais	Relé
25	6110516M1	Power	2	Relay	Relais	Relé
26	6110700M91	25 x 25mm Velcro	1	Strip, Sealing	Bande d'étanchéité	Banda estanqueidad



820 880
 TX760B TX860B
 TX870B

803 804 807 808 841 842 843 844 845

57014C01.1

6199042M3

1

Jan-06

Front Lighting
Feux Avant
Luces delanteras

Headlights
Phares
Faros

Left hand dip
 Feu de croisement gauche
 Luz izquierda

C-60001-01.1-A

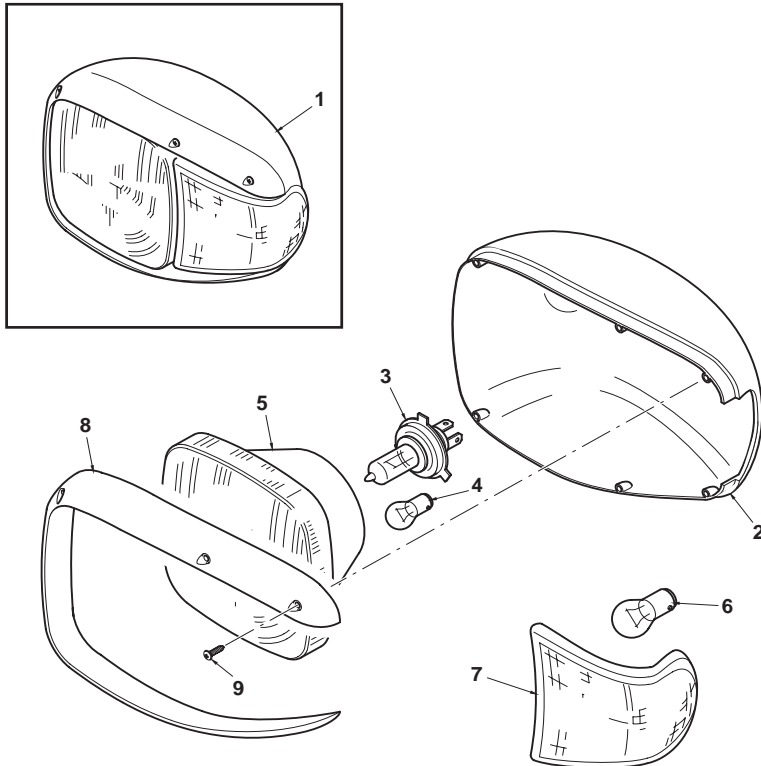

1	6106301M91		◀	1	Headlight	Phare	Faro
1	6106302M91		▶	1	Headlight	Phare	Faro
2		1	▶ Ref. 1	1	Body	Corps	Cuerpo
3	3523444M1	1	55/60w	1	Bulb	Lampe	Lámpara
4	3523690M1	1	4W	1	Bulb	Lampe	Lámpara
5		1	▶ Ref. 1	1	Lens	Lentille	Lente
6	3523687M1	1	21W Indicator	1	Bulb	Lampe	Lámpara
7		1	▶ Ref. 1	1	Lens	Lentille	Lente
8		1	▶ Ref. 1	1	Rim	Jante	Corona
9		1	▶ Ref. 1	6	Screw	Vis	Tornillo



820 860 880 970 980
 TX760B TX860B
 TX870B TX970B

801 802 803 804 805 806 807 808 813 814 815 816 817 821 822 823 824 825 831
 832 833 834 841 842 843 844 845 851 852 853 854 855 921 922 923 931 932

60001C01.1

6199042M3

1

Jan-06

Front Lighting
Feux Avant
Luces delanteras

Headlights
Phares
Faros

Right hand dip
 Feu de croisement droit
 Luz derecha

C-60002-01.1-A

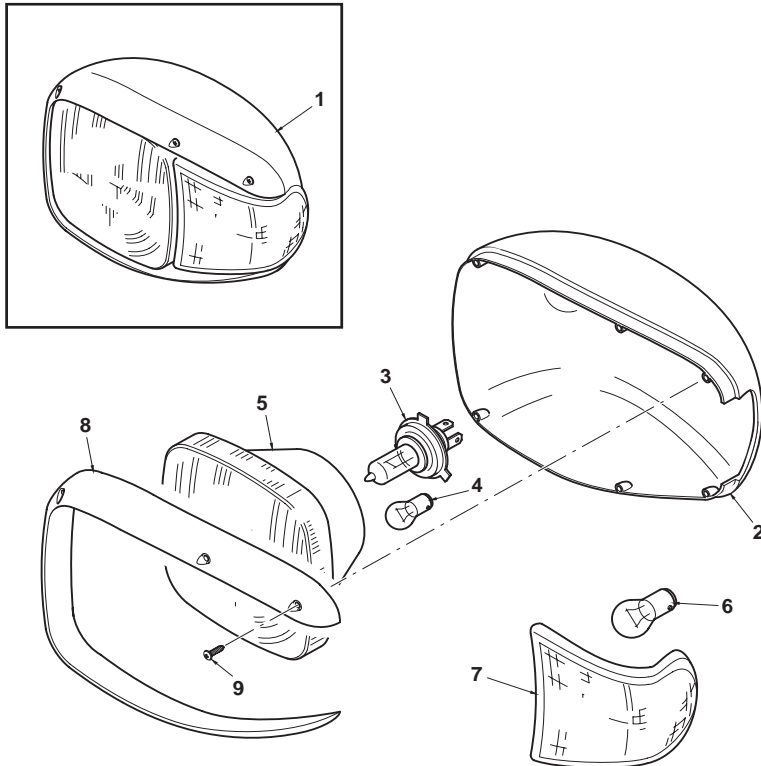

1	6106303M91		◀	1	Headlight	Phare	Faro
1	6106304M91		▶	1	Headlight	Phare	Faro
2		1	▶ Ref. 1	1	Body	Corps	Cuerpo
3	3523444M1	1	55/60w	1	Bulb	Lampe	Lámpara
4	3523690M1	1	4W	1	Bulb	Lampe	Lámpara
5		1	▶ Ref. 1	1	Lens	Lentille	Lente
6	3523687M1	1	21W Indicator	1	Bulb	Lampe	Lámpara
7		1	▶ Ref. 1	1	Lens	Lentille	Lente
8		1	▶ Ref. 1	1	Rim	Jante	Corona
9		1	▶ Ref. 1	6	Screw	Vis	Tornillo



820 860 880 970 980
 TX760B TX860B
 TX870B TX970B

801 802 803 804 805 806 807 808 809 810 811 812 813 814 815 816 817 821 822
 823 824 825 831 832 833 834 841 842 843 844 845 851 852 853 854 855 921 922
 923 931 932

60002C01.1

6199042M3

1

Jan-06

Rear Lighting
Feux Arrière
Luces traseras

Centremount
Montage de Pelle Central
Excavadora de montaje central

C-59002-01.1-A

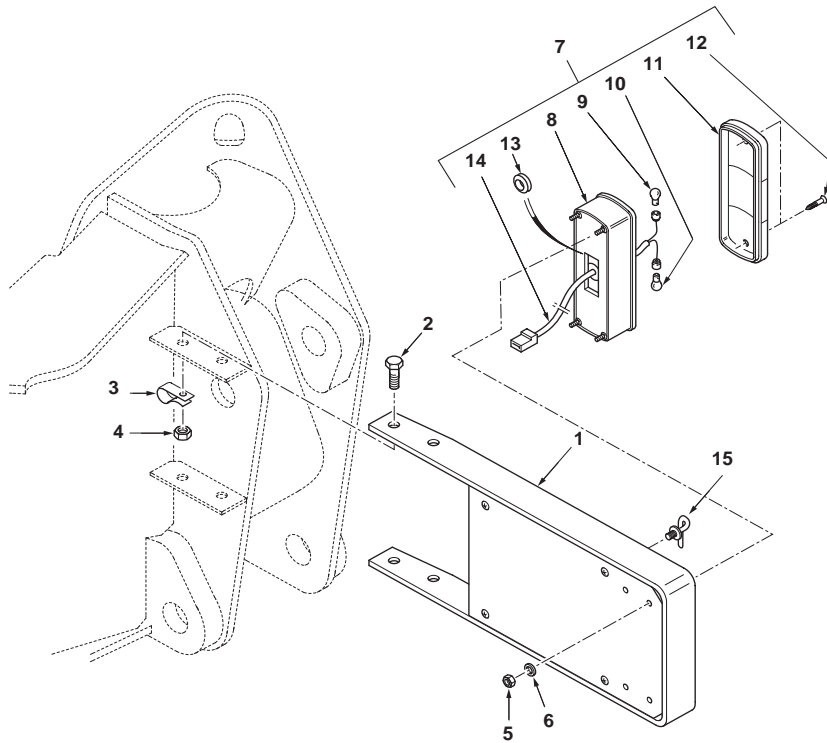

1	6101415M91		2	Mount	Support de fixation	Soporte de fijación
2	3009494X1	M10 x 35	8	Screw	Vis	Tornillo
3	371643X1		2	Clip, Mounting	Collier de fixation	Argolla de fijación
4	1440329X1	M10	8	Nut, Lock	Écrou de blocage	Tuerca de retención
5	390995X1	M5	8	Nut	Écrou	Tuerca
6	339381X1	M5	8	Washer, Lock	Rondelle de blocage	Arandela de freno
7	6101410M91		2	Lamp, Tail	Feu arrière	Luz Posterior
8		7 Ref. 7	1	Body	Corps	Cuerpo
9	3523687M1	7 21W Indicator	1	Bulb	Lampe	Lámpara
10	3523688M1	7 21W Stop/ 5W Tail	1	Bulb	Lampe	Lámpara
11	6190744M1	7	1	Lens	Lentille	Lente
12		7 Ref. 7	2	Screw	Vis	Tornillo
13		7 Ref. 7	1	Grommet	Passe-fil	Pasa cable
14		7 Ref. 7	1	Harness	Faisceau	Haz
15	6102985M1	Fir tree	4	Tie, Cable	Attache câble	Enlace de Cable



820 860 880 970 980
TX760B TX860B
TX870B TX970B

801 803 813 815 821 823 831 841 843 851 853 922 923 932

59002C01.1

6199042M3

1

Jan-06

Rear Lighting
Feux Arrière
Luces traseras

ROPS
ROPS
ROPS

C-59003-01.1-A

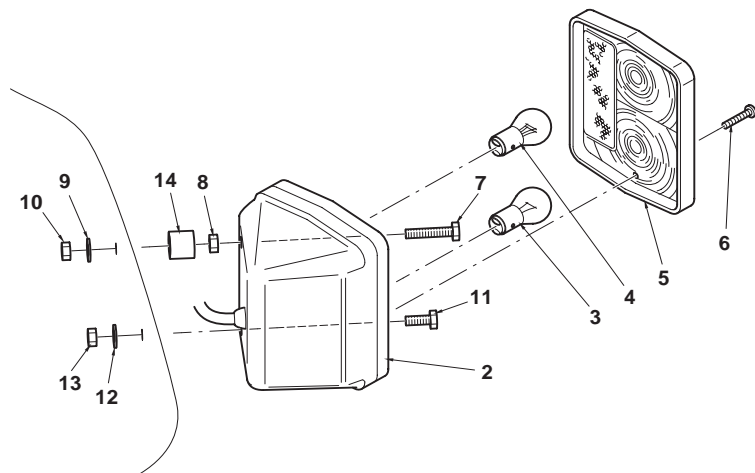

1	6107972M91		◀	1	Lamp, Tail	Feu arrière	Luz Posterior
1	6107973M91		▶	1	Lamp, Tail	Feu arrière	Luz Posterior
2		1	▶	1	Body	Corps	Cuerpo
3	3523687M1	1	21W Indicator	1	Bulb	Lampe	Lámpara
4	3523688M1	1	21W Stop/ 5W Tail	1	Bulb	Lampe	Lámpara
5	6193294M1	1	◀	1	Lens	Lentille	Lente
5	6193295M1	1	▶	1	Lens	Lentille	Lente
6		5	▶	2	Screw	Vis	Tornillo
7	1441268X1	1	M6 x 30	1	Screw	Vis	Tornillo
8	339030X1	1	M6	1	Nut	Écrou	Tuerca
9	390971X1	1	M6	1	Washer	Rondelle	Arandela
10	339030X1	1	M6	1	Nut	Écrou	Tuerca
11	339560X1	1	M6 x 16	1	Screw	Vis	Tornillo
12	390971X1	1	M6	1	Washer	Rondelle	Arandela
13	339030X1	1	M6	1	Nut	Écrou	Tuerca
14	6107983M1			2	Spacer	Entretoise	Traviesa



820 860 880
TX760B TX860B
TX870B

801 803 809 811 813 815 821 823 831 841 843 851 853

59003C01.1

6199042M3

1

Jan-06

Rear Lighting
Feux Arrière
Luces traseras

ROPS
ROPS
ROPS

4 Post ROPS
4 Poteau ROPS
4 poste ROPS

C-59004-01.1-A

1	6108752M91			2	Lamp, Tail	Feu arrière	Luz Posterior
2		1		1	Body	Corps	Cuerpo
3	6193658M1	1	AMBER	1	Lens	Lentille	Lente
4	6193659M1	1	RED	1	Lens	Lentille	Lente
5		1		2	Nut	Écrou	Tuerca
6		1		2	Washer	Rondelle	Arandela
7		1		1	Harness	Faisceau	Haz

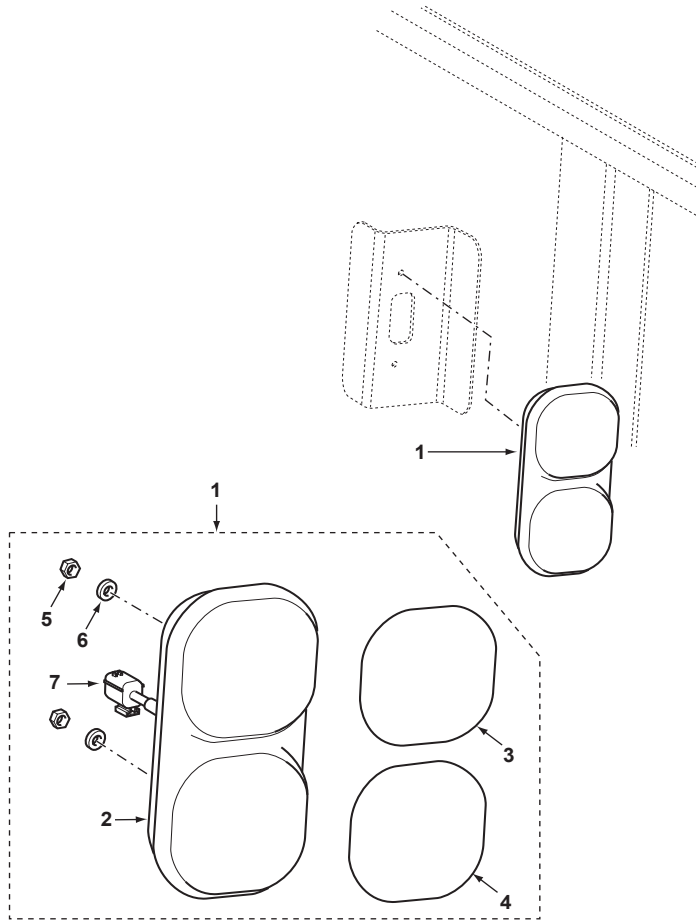

820 860 880
TX760B TX860B
TX870B

802 804 806 808 810 812 814 816 822 824 832 834 842 844 852 854

59004C01.1

6199042M3

1

Jan-06

Rear Lighting
Feux Arrière
Luces traseras

Sideshift
Montage de Pelle Latéral
Excavadora de montaje horizontal

C-59001-01.1-A

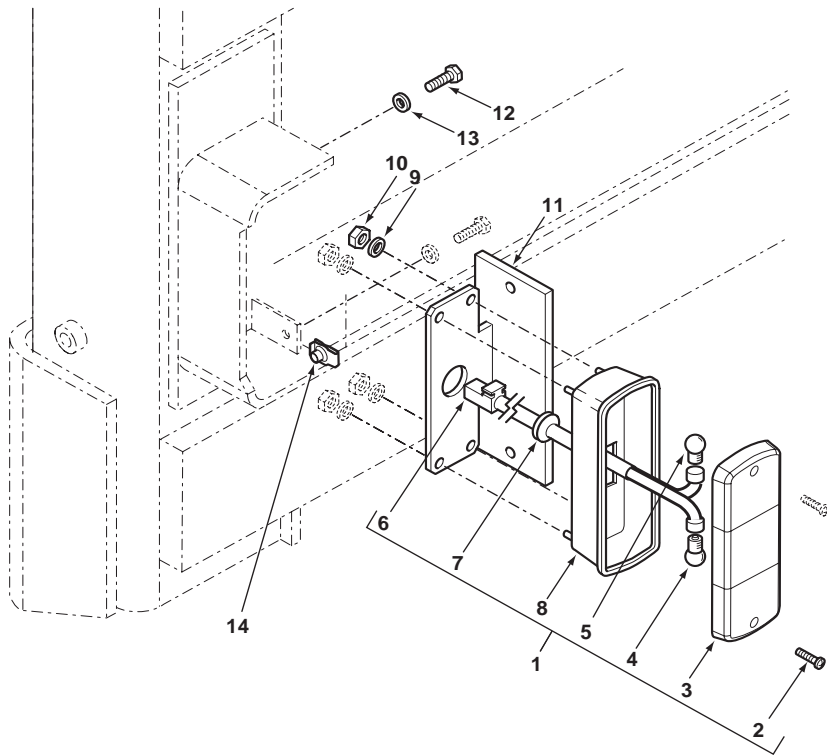

1	6101410M91		2	Lamp, Tail	Feu arrière	Luz Posterior
2		1	2	Screw	Vis	Tornillo
3	6190744M1	1	1	Lens	Lentille	Lente
4	3523688M1	1	1	21W Stop/ 5W Tail	Lampe	Lámpara
5	3523687M1	1	1	21W Indicator	Lampe	Lámpara
6		1	1	Harness	Faisceau	Haz
7		1	1	Grommet	Passe-fil	Pasa cable
8		1	1	Body	Corps	Cuerpo
9	390469X1	M5	8	Washer	Rondelle	Arandela
10	390995X1	M5	8	Nut	Écrou	Tuerca
11	6106809M92		2	Plate Assy	Ensemble de plaque	Placa, Conj.
12	339761X1	M8 x 25	4	Screw	Vis	Tornillo
13	390972X1	M8	4	Washer	Rondelle	Arandela
14	6106899M1	M8	4	Nut, Flange	Écrou à flasque	Tuerca con horquilla



820 860 880 970 980
 TX760B TX860B

805 807 817 825 833 845 855 921 931

59001C01.1

6199042M3

1

Jan-06

K - Chassis And Bodywork • Châssis et carrosserie • Chasis y carrocería

Chassis - Centremount.....	10013C01.1	Châssis - Montage de Pelle Central	Chasis - Excavadora de montaje central
Chassis - Centremount.....	10014C01.1	Châssis - Montage de Pelle Central	Chasis - Excavadora de montaje central
Chassis - Centremount.....	10015C01.1	Châssis - Montage de Pelle Central	Chasis - Excavadora de montaje central
Chassis - Sideshift.....	10010C01.1	Châssis - Montage de Pelle Latéral	Chasis - Excavadora de montaje horizontal
Chassis - Sideshift.....	10011C01.1	Châssis - Montage de Pelle Latéral	Chasis - Excavadora de montaje horizontal
Chassis - Sideshift.....	10012C01.1	Châssis - Montage de Pelle Latéral	Chasis - Excavadora de montaje horizontal
Engine Cover.....	12001C01.1	Capot Moteur	Capó de motor
Engine Cover.....	12002C01.1	Capot Moteur	Capó de motor
Hardnose And Grille.....	20010C01.1	Embout Stellité et Calandre	Carcasa rígida y rejilla
Rear Fenders.....	83001C01.1	Ailes Arrière	Guardabarros traseros
Rear Fenders.....	83002C01.1	Ailes Arrière	Guardabarros traseros
Rear Fenders.....	83003C01.1	Ailes Arrière	Guardabarros traseros
Rear Fenders.....	83004C01.1	Ailes Arrière	Guardabarros traseros
Rear Fenders.....	83005C01.1	Ailes Arrière	Guardabarros traseros
Rear Fenders.....	83006C01.1	Ailes Arrière	Guardabarros traseros
Rear Fenders.....	83007C01.1	Ailes Arrière	Guardabarros traseros
Rear Fenders.....	83008C01.1	Ailes Arrière	Guardabarros traseros
Rear Fenders.....	83009C01.1	Ailes Arrière	Guardabarros traseros
Rear Fenders.....	83010C01.1	Ailes Arrière	Guardabarros traseros
Rear Fenders - Sideshift Mudguard.....	83001C02.1	Ailes Arrière - Garde-boue Tablier de Déplacement Latéral	Guardabarros traseros - Laterales
Rear Fenders - Sideshift Mudguard.....	83002C02.1	Ailes Arrière - Garde-boue Tablier de Déplacement Latéral	Guardabarros traseros - Laterales
Rear Fenders - Sideshift Mudguard.....	83003C02.1	Ailes Arrière - Garde-boue Tablier de Déplacement Latéral	Guardabarros traseros - Laterales
Rear Fenders - Sideshift Mudguard.....	83008C02.1	Ailes Arrière - Garde-boue Tablier de Déplacement Latéral	Guardabarros traseros - Laterales



Chassis
Châssis
Chasis

Centremount
Montage de Pelle Central
Excavadora de montaje central

Short
Court
Corto

C-10013-01.1-A

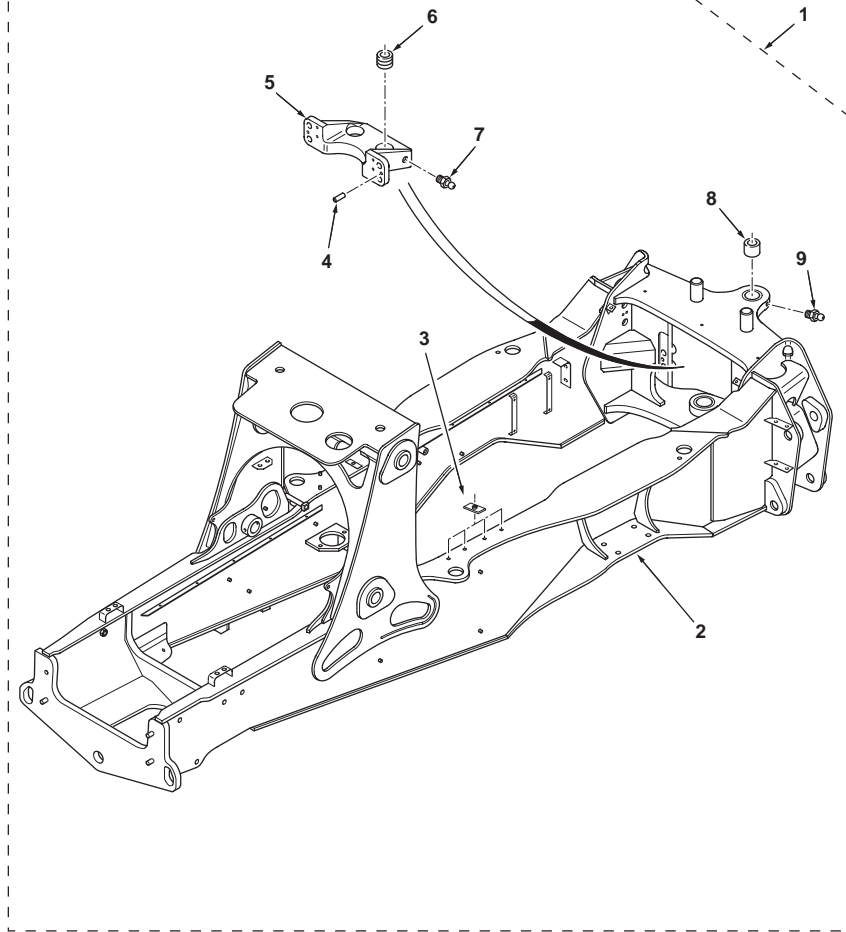

1	6110037M92		2WS	1	Chassis	Châssis	Chasis
2		1	➡ Ref. 1	1	Chassis	Châssis	Chasis
3	1470375M1	1		6	Mount	Support de fixation	Soporte de fijación
4	3522954M1	1	12 x 55 mm	2	Pin, Dowel	Goupille position.	Peón
5		1	➡ Ref. 1	1	Mount	Support de fixation	Soporte de fijación
6	3521388M5	1		4	Bushing	Bague	Anillo
7	339608X1	1		3	Fitting, Grease	Graisneur	Engrasador
8	3517246M2	1		2	Bushing	Bague	Anillo
9	339608X1	1		3	Fitting, Grease	Graisneur	Engrasador



820 860 880
TX760B TX860B
TX870B

803 804 809 810 811 812 813 814 815 816 821 822 823 824 831 832 841 842 843
844 851 852 853 854

10013C01.1

6199042M3

1

Jan-06

Chassis
Châssis
Chasis

Centremount
Montage de Pelle Central
Excavadora de montaje central

Long
Long
Largo

C-10014-01.1-A

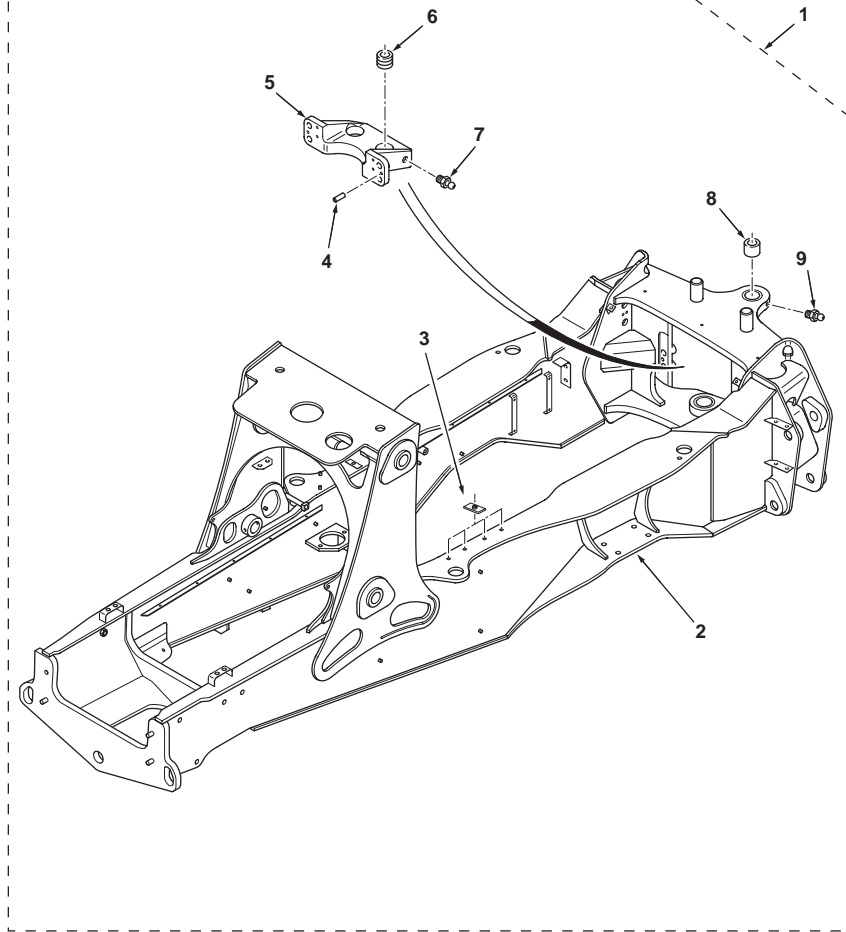

1	6110038M93		2WS	1	Chassis	Châssis	Chasis
2		1	➡ Ref. 1	1	Chassis	Châssis	Chasis
3	1470375M1	1		6	Mount	Support de fixation	Soporte de fijación
4	3522954M1	1	12 x 55 mm	2	Pin, Dowel	Goupille position.	Peón
5		1	➡ Ref. 1	1	Mount	Support de fixation	Soporte de fijación
6	3521388M5	1		4	Bushing	Bague	Anillo
7	339608X1	1		3	Fitting, Grease	Graisneur	Engrasador
8	3517246M2	1		2	Bushing	Bague	Anillo
9	339608X1	1		3	Fitting, Grease	Graisneur	Engrasador



820
TX760B

801 802

10014C01.1

6199042M3

1

Jan-06

Chassis
Châssis
Chasis

Centremount
Montage de Pelle Central
Excavadora de montaje central

4 Wheel Steer
4 Roues Directrices
Dirección en las 4 ruedas

C-10015-01.1-A

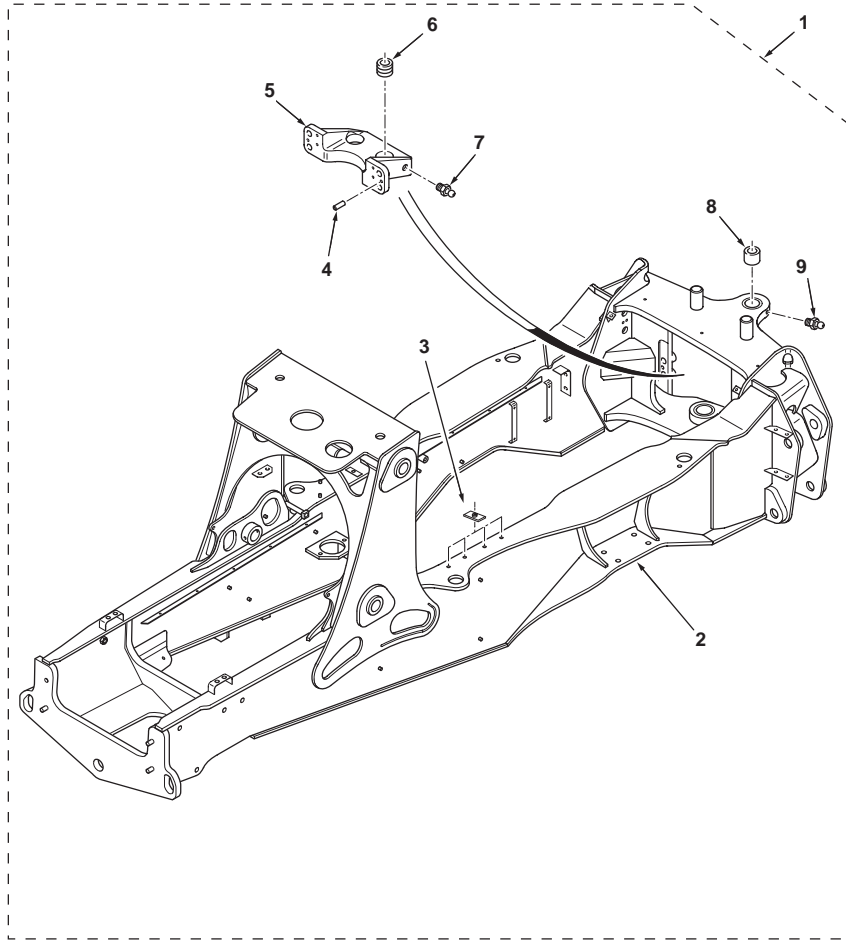

1	6110039M93		4WS	1	Chassis	Châssis	Chasis
2		1	➡ Ref. 1	1	Chassis	Châssis	Chasis
3	1470375M1	1		6	Mount	Support de fixation	Soporte de fijación
4	3522954M1	1	12 x 55 mm	2	Pin, Dowel	Goupille position.	Peón
5		1	➡ Ref. 1	1	Mount	Support de fixation	Soporte de fijación
6	3521388M5	1		4	Bushing	Bague	Anillo
7	339608X1	1		3	Fitting, Grease	Graisneur	Engrasador
8	3517246M2	1		2	Bushing	Bague	Anillo
9	339608X1	1		3	Fitting, Grease	Graisneur	Engrasador



970 980
TX970B

922 923 932

10015C01.1

6199042M3

1

Jan-06

Chassis
Châssis
Chasis

Sideshift
Montage de Pelle Latéral
Excavadora de montaje horizontal

Short
Court
Corto

C-10010-01.1-A

1	6110034M92		2WS	1	Chassis	Châssis	Chasis
2		1	 Ref. 1	1	Chassis	Châssis	Chasis
3	1470375M1	1		6	Mount	Support de fixation	Soporte de fijación

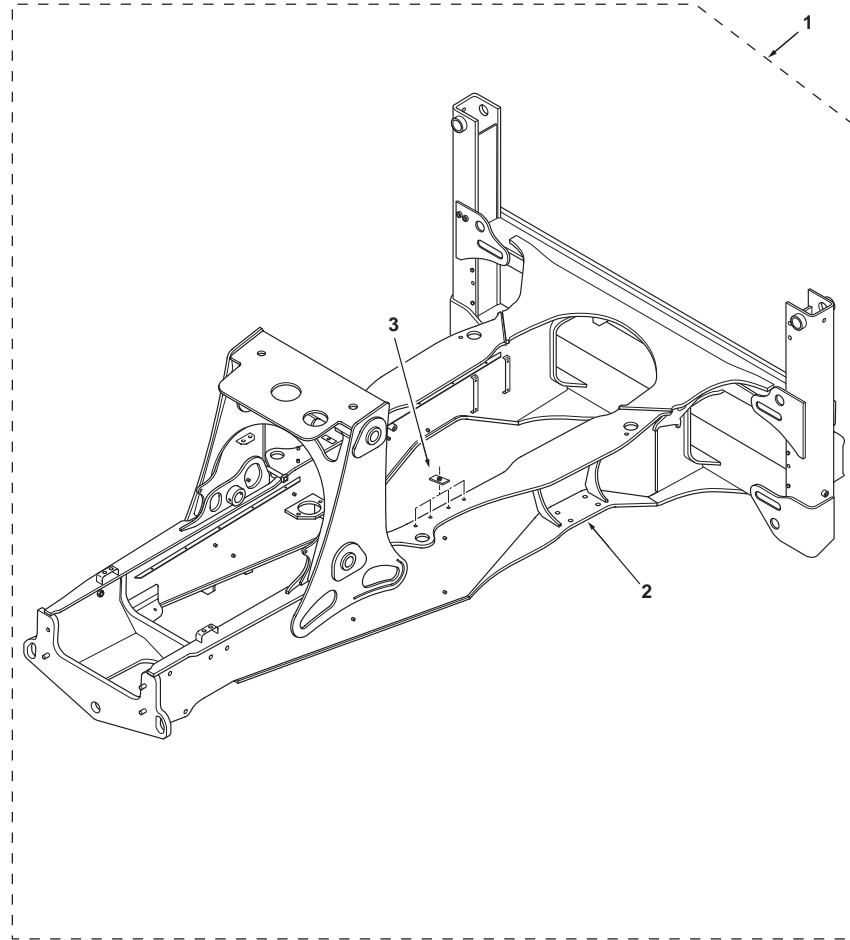

860 880
TX860B

817 825 845 855

10010C01.1

6199042M3

1

Jan-06

Chassis
Châssis
Chasis

Sideshift
Montage de Pelle Latéral
Excavadora de montaje horizontal

Long
Long
Largo

C-10011-01.1-A

1	6110035M93		2WS	1	Chassis	Châssis	Chasis
2		1	 Ref. 1	1	Chassis	Châssis	Chasis
3	1470375M1	1		6	Mount	Support de fixation	Soporte de fijación

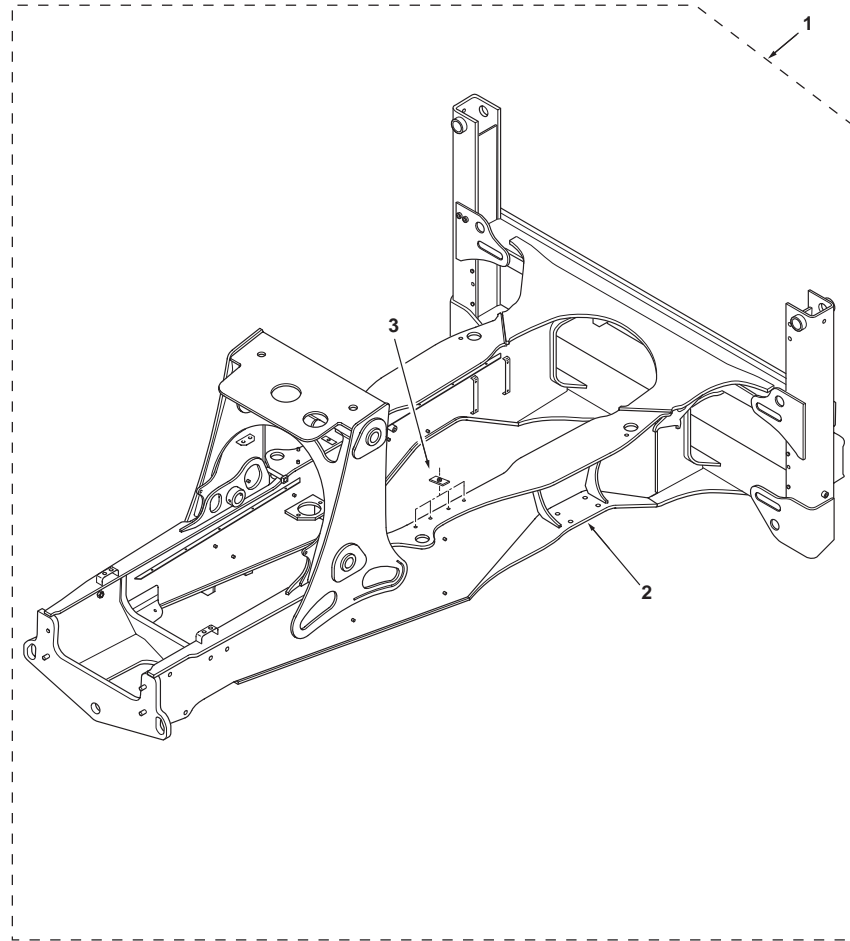

820
TX760B

805 806 807 808 833 834

10011C01.1

6199042M3

1

Jan-06

Chassis
Châssis
Chasis

Sideshift
Montage de Pelle Latéral
Excavadora de montaje horizontal

4 Wheel Steer
4 Roues Directrices
Dirección en las 4 ruedas

C-10012-01.1-A

1	6110036M93		4WS	1	Chassis	Châssis	Chasis
2		1	 Ref. 1	1	Chassis	Châssis	Chasis
3	1470375M1	1		6	Mount	Support de fixation	Soporte de fijación

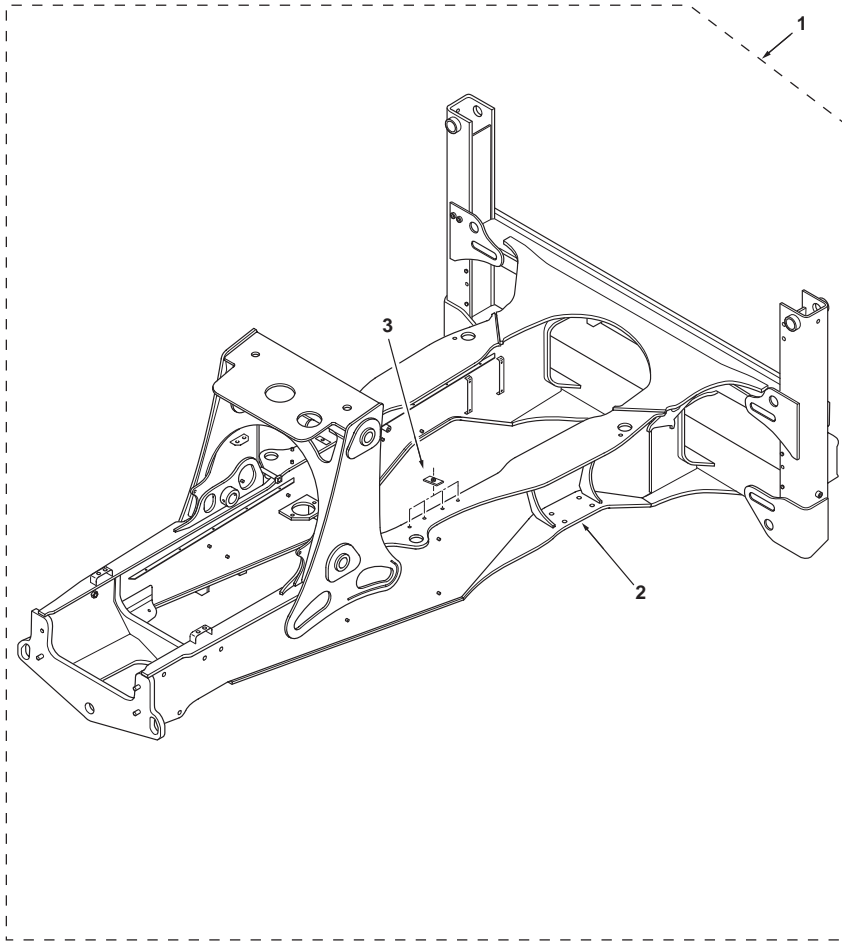

970 980

921 931

10012C01.1

6199042M3

1

Jan-06

**Engine Cover
Capot Moteur
Capó de motor**

Yellow
Jaune
Amarillo

C-12001-01.1-A

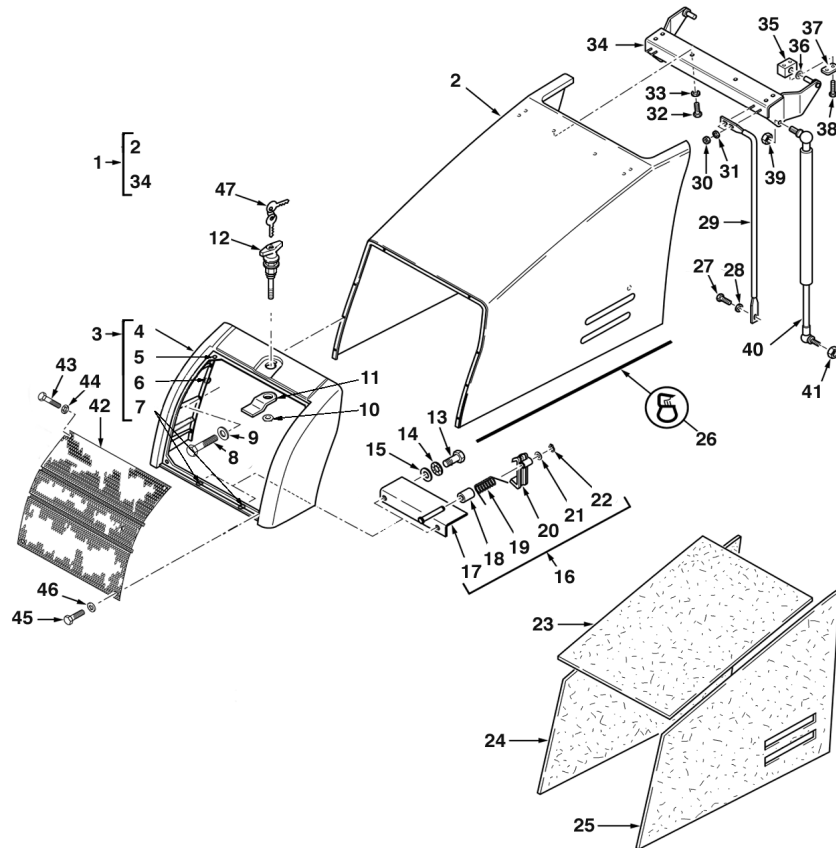

1	6109917M91			1	Hood Assy, Engine	Ensem. capot moteur	Capó de motor, Conj.
2	6100722M91	1		1	Cover	Cache	Tapa
3	6101058M92	1		1	Nose Assy	Ensemble de nez	Morro, Conj.
4		3	➡ Ref. 3	1	Nose	Nez	Morro
5	6101246M1	3	M6	8	Nut, Special	Ecrou Special	Tuerca especial
6	6100785M1	3	M6	2	Insert	Insert	Inserción
7	6102674M2	3		4	Latch	Loquet	Picaporte
8	339804X1	1	M6 x 25	8	Screw	Vis	Tornillo
9	390971X1	1	M6	8	Washer	Rondelle	Arandela
10	1440329X1	1	M10	1	Nut, Lock	Écrou de blocage	Tuerca de retención
11	6108647M1	1		1	Cam	Came	Leva
12	6108646M91	1		1	Lock Assy	Ensemble de verrou	Cerradura, Conj.
13	339124X1	1	M8 x 16	2	Screw	Vis	Tornillo
14	339374X1	1	M8	2	Washer, Lock	Rondelle de blocage	Arandela de freno
15	390972X1	1	M8	2	Washer	Rondelle	Arandela
16	6100960M92	1		1	Latch	Loquet	Picaporte
17		16	➡ Ref. 16	1	Bracket	Patte de fixation	Pata de fijación
18	6101529M1	16		1	Spacer	Entretoise	Traviesa
19	3521090M3	16		1	Spring	Ressort	Muelle
20	6106050M91	16		1	Latch	Loquet	Picaporte
21	390972X1	16	M8	1	Washer	Rondelle	Arandela
22	1440522X1	16		1	Ring, Snap	Anneau d'arrêt	Anillo de resorte
23	6101175M2	1		1	Insulation	Isolation	Aislante
24	6101176M1	1	▶	1	Insulation	Isolation	Aislante
25	6101177M1	1	◀	1	Insulation	Isolation	Aislante
26	6101241M1	1	945 mm	2	Seal	Joint	Junta
27	339124X1	1	M8 x 16	2	Screw	Vis	Tornillo
28	385361X1	1	M8	2	Washer	Rondelle	Arandela
29	6102023M1	1		2	Tube	Tube	Tubo
30	394367X1	1	M8	4	Nut, Lock	Écrou de blocage	Tuerca de retención
31	385361X1	1	M8	4	Washer	Rondelle	Arandela
32	339124X1	1	M8 x 16	6	Screw	Vis	Tornillo
33	390972X1	1	M8	6	Washer	Rondelle	Arandela
34	6102084M91	1		1	Mount	Support de fixation	Soporte de fijación
35	6102086M1			2	Support	Support	Soporte
36	1441664X1			2	Washer	Rondelle	Arandela
37	1462583M1			2	Plate	Plaque	Placa
38	339229X1		M6 x 40	4	Screw	Vis	Tornillo
39	394367X1		M8	2	Nut, Lock	Écrou de blocage	Tuerca de retención
40	6109853M91			2	Gas Strut	Vérin à gaz	Gato de gas
41	394367X1		M8	2	Nut, Lock	Écrou de blocage	Tuerca de retención
42	6101133M91			1	Grille	Grille	Rejilla
43	391884X1		M6 x 50	2	Screw	Vis	Tornillo
44	391038X1		M6	2	Washer	Rondelle	Arandela



820 860 880 970 980
TX760B TX860B
TX870B TX970B

801 802 803 804 805 806 807 808 813 814 815 816 817 821 822 823 824 825 831
832 833 834 841 842 843 844 845 851 852 853 854 855 921 922 923 931 932

12001C01.1

6199042M3

1

Jan-06

Engine Cover
Capot Moteur
Capó de motor

Yellow
Jaune
Amarillo

C-12001-01.1-A

45	339560X1	M6 x 16	2	Screw	Vis	Tornillo
46	391038X1	M6	2	Washer	Rondelle	Arandela
47	6107891M1	Terex Logo (Pair)	2	Keys, Set	Lot de clés	Juego de llaves

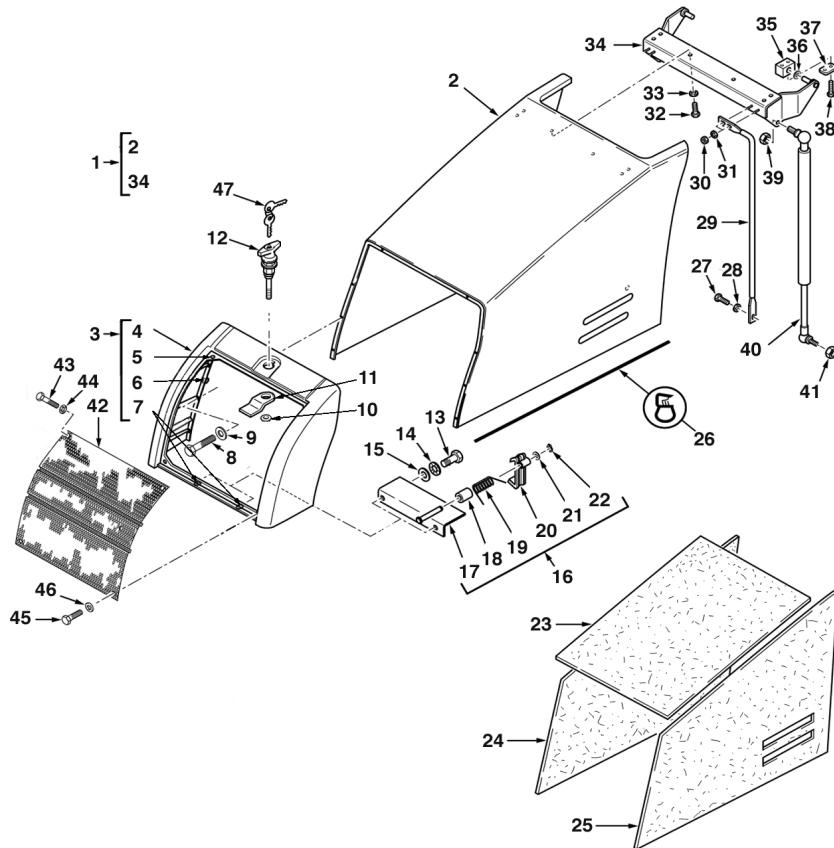

820 860 880 970 980
TX760B TX860B
TX870B TX970B

801 802 803 804 805 806 807 808 813 814 815 816 817 821 822 823 824 825 831
832 833 834 841 842 843 844 845 851 852 853 854 855 921 922 923 931 932

12001C01.1

6199042M3

1

Jan-06

**Engine Cover
Capot Moteur
Capó de motor**

White
Blanc
Blanco

C-12002-01.1-A

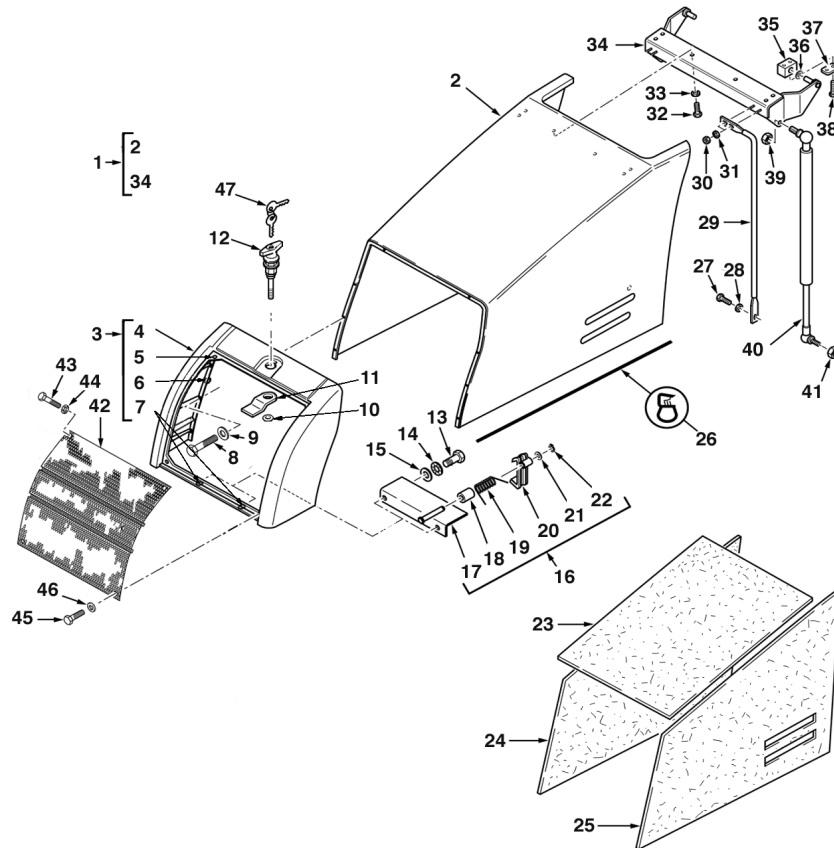

1	6109918M91			1	Hood Assy, Engine	Ensem. capot moteur	Capó de motor, Conj.
2	6107887M91	1		1	Cover	Cache	Tapa
3	6101058M92	1		1	Nose Assy	Ensemble de nez	Morro, Conj.
4		3	➡ Ref. 3	1	Nose	Nez	Morro
5	6101246M1	3	M6	8	Nut, Special	Ecrou Special	Tuerca especial
6	6100785M1	3	M6	2	Insert	Insert	Inserción
7	6102674M2	3		4	Latch	Loquet	Picaporte
8	339804X1	1	M6 x 25	8	Screw	Vis	Tornillo
9	390971X1	1	M6	8	Washer	Rondelle	Arandela
10	1440329X1	1	M10	1	Nut, Lock	Écrou de blocage	Tuerca de retención
11	6108647M1	1		1	Cam	Came	Leva
12	6108646M91	1		1	Lock Assy	Ensemble de verrou	Cerradura, Conj.
13	339124X1	1	M8 x 16	2	Screw	Vis	Tornillo
14	339374X1	1	M8	2	Washer, Lock	Rondelle de blocage	Arandela de freno
15	390972X1	1	M8	2	Washer	Rondelle	Arandela
16	6100960M92	1		1	Latch	Loquet	Picaporte
17		16	➡ Ref. 16	1	Bracket	Patte de fixation	Pata de fijación
18	6101529M1	16		1	Spacer	Entretoise	Travesa
19	3521090M3	16		1	Spring	Ressort	Muelle
20	6106050M91	16		1	Latch	Loquet	Picaporte
21	390972X1	16	M8	1	Washer	Rondelle	Arandela
22	1440522X1	16		1	Ring, Snap	Anneau d'arrêt	Anillo de resorte
23	6101175M2	1		1	Insulation	Isolation	Aislante
24	6101176M1	1	▶	1	Insulation	Isolation	Aislante
25	6101177M1	1	◀	1	Insulation	Isolation	Aislante
26	6101241M1	1	945 mm	2	Seal	Joint	Junta
27	339124X1	1	M8 x 16	2	Screw	Vis	Tornillo
28	385361X1	1	M8	2	Washer	Rondelle	Arandela
29	6102023M1	1		2	Tube	Tube	Tubo
30	394367X1	1	M8	4	Nut, Lock	Écrou de blocage	Tuerca de retención
31	385361X1	1	M8	4	Washer	Rondelle	Arandela
32	339124X1	1	M8 x 16	6	Screw	Vis	Tornillo
33	390972X1	1	M8	6	Washer	Rondelle	Arandela
34	6102084M91	1		1	Mount	Support de fixation	Soporte de fijación
35	6102086M1			2	Support	Support	Soporte
36	1441664X1			2	Washer	Rondelle	Arandela
37	1462583M1			2	Plate	Plaque	Placa
38	339229X1		M6 x 40	4	Screw	Vis	Tornillo
39	394367X1		M8	2	Nut, Lock	Écrou de blocage	Tuerca de retención
40	6109853M91			2	Gas Strut	Vérin à gaz	Gato de gas
41	394367X1		M8	2	Nut, Lock	Écrou de blocage	Tuerca de retención
42	6101133M91			1	Grille	Grille	Rejilla
43	391884X1		M6 x 50	2	Screw	Vis	Tornillo
44	391038X1		M6	2	Washer	Rondelle	Arandela



820 860 880 970 980
TX760B TX860B
TX870B TX970B

801 802 803 804 805 806 807 808 809 810 811 812 813 814 815 816 817 821 822
823 824 825 831 832 833 834 841 842 843 844 845 851 852 853 854 855 921 922
923 931 932

12002C01.1

6199042M3

1

Jan-06

Engine Cover
Capot Moteur
Capó de motor

White
Blanc
Blanco

C-12002-01.1-A

45	339560X1	M6 x 16	2	Screw	Vis	Tornillo
46	391038X1	M6	2	Washer	Rondelle	Arandela
47	6107891M1	Terex Logo (Pair)	2	Keys, Set	Lot de clés	Juego de llaves

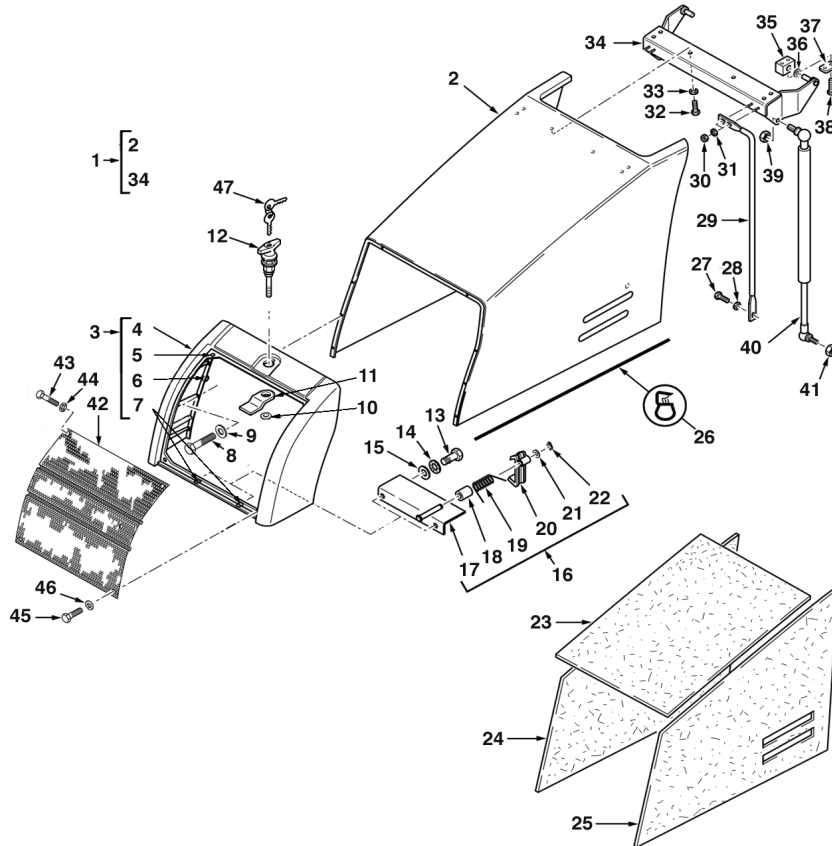

820 860 880 970 980
TX760B TX860B
TX870B TX970B

801 802 803 804 805 806 807 808 809 810 811 812 813 814 815 816 817 821 822
823 824 825 831 832 833 834 841 842 843 844 845 851 852 853 854 855 921 922
923 931 932

12002C01.1

6199042M3

1

Jan-06

Hardnose And Grille
Embout Stellité et Calandre
Carcasa rígida y rejilla

C-20010-01.1-A

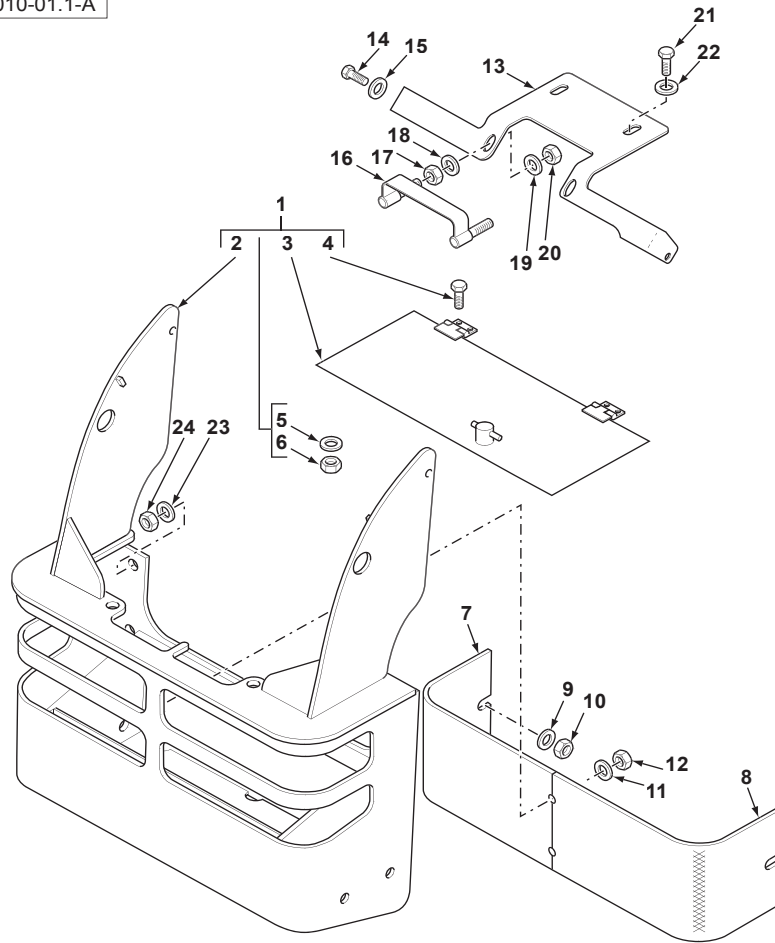

1	6110105M91		1	Hardnose	Embout stellite	Carcasa rígida
2		1	Ref. 1	Frame	Bâti	Bastidor
3	6110134M91	1		Cover Assy	Ensemble de couvercle	Tapa, Conj.
4	339666X1	1	M6 x 20	Screw	Vis	Tornillo
5	390971X1	1	M6	Washer	Rondelle	Arandela
6	1441500X1	1	M6	Nut, Lock	Écrou de blocage	Tuerca de retención
7	6110138M2			Grille	Grille	Rejilla
8	6110136M92			Grille Assy	Grille	Rejilla
9	390972X1		M8	Washer	Rondelle	Arandela
10	394367X1		M8	Nut, Lock	Écrou de blocage	Tuerca de retención
11	390972X1		M8	Washer	Rondelle	Arandela
12	394367X1		M8	Nut, Lock	Écrou de blocage	Tuerca de retención
13	6109350M91			Support Assy	Ensemble de support	Apoyadero, Conj.
14	3009493X1		M10 x 30	Bolt	Boulon	Perno
15	390734X1		M10	Washer	Rondelle	Arandela
16	6109686M92			Latch Assy	Ensemble de verrou	Cerrojo, Conj.
17	339169X1		M8	Nut	Écrou	Tuerca
18	390972X1		M8	Washer	Rondelle	Arandela
19	390972X1		M8	Washer	Rondelle	Arandela
20	339169X1		M8	Nut	Écrou	Tuerca
21	339123X1		M8 x 20	Bolt	Boulon	Perno
22	390972X1		M8	Washer	Rondelle	Arandela
23	3019575X1		M16	Washer	Rondelle	Arandela
24	339034X1		M16	Nut	Écrou	Tuerca



820 860 880 970 980
 TX760B TX860B
 TX870B TX970B

801 802 803 804 805 806 807 808 809 810 811 812 813 814 815 816 817 821 822
 823 824 825 831 832 833 834 841 842 843 844 845 851 852 853 854 855 921 922
 923 931 932

20010C01.1

6199042M3

1

Jan-06

Rear Fenders
Ailes Arrière
Guardabarros traseros

2 Wheel Steer
 2 Roues Directrices
 Dirección en 2 ruedas

C-83001-01.1-A

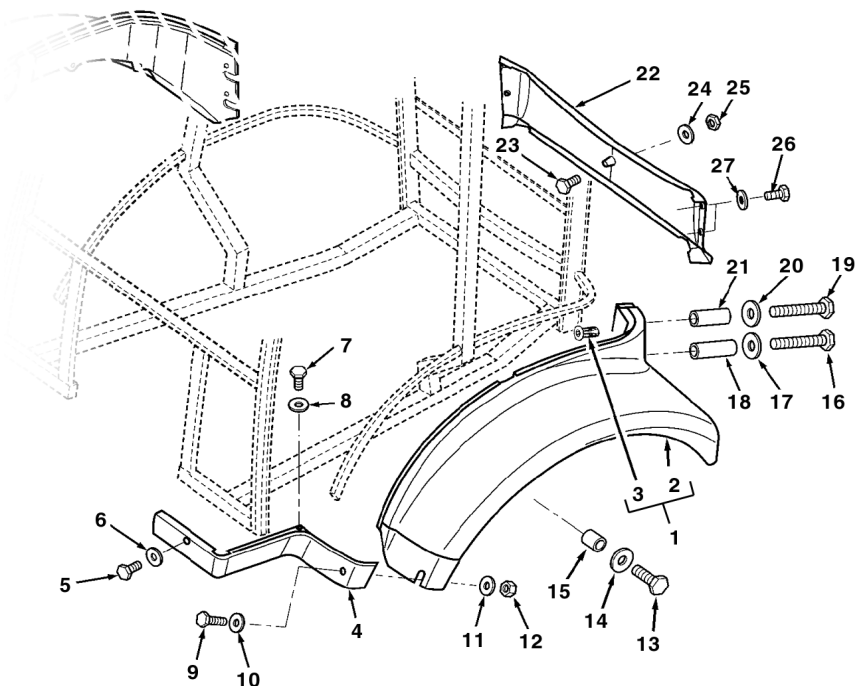

1	6101780M91	◀ Yellow	1	Fender Assy	Ensemble d'aile	Guardabarros, Conj.
1	6101781M91	▶ Yellow	1	Fender Assy	Ensemble d'aile	Guardabarros, Conj.
2		1 ▶ Ref. 1	1	Fender	Aile	Aleta
3	6101246M1	1 M6	2	Nut, Special	Ecrou Special	Tuerca especial
4	6099516M1	◀ Yellow	1	Sill	Rebord	Pieza de apoyo
4	6099517M1	▶ Yellow	1	Sill	Rebord	Pieza de apoyo
5	840-1620	M6 x 20	2	Screw	Vis	Tornillo
6	390971X1	M6	2	Washer	Rondelle	Arandela
7	6108652M1	M6 x 20	2	Screw	Vis	Tornillo
8	390972X1	M8	2	Washer	Rondelle	Arandela
9	3008229X1	M6 x 30	2	Screw	Vis	Tornillo
10	390971X1	M6	2	Washer	Rondelle	Arandela
11	6102079M1	M6	2	Washer	Rondelle	Arandela
12	1441500X1	M6	2	Nut, Lock	Écrou de blocage	Tuerca de retención
13	339009X1	M8 x 35	8	Screw	Vis	Tornillo
14	391039X1	M8	8	Washer	Rondelle	Arandela
15	6101730M1		8	Spacer	Entretoise	Traviesa
16	339891X1	M8 x 80	2	Screw	Vis	Tornillo
17	391039X1	M8	2	Washer	Rondelle	Arandela
18	6101732M2		2	Spacer	Entretoise	Traviesa
19	339891X1	M8 x 80	2	Screw	Vis	Tornillo
20	391039X1	M8	2	Washer	Rondelle	Arandela
21	6101731M2		2	Spacer	Entretoise	Traviesa
22	6099515M1	Yellow	1	Panel	Panneau	Panel
23	339804X1	M6 x 25	1	Screw	Vis	Tornillo
24	391038X1	M6	1	Washer	Rondelle	Arandela
25	1441500X1	M6	1	Nut, Lock	Écrou de blocage	Tuerca de retención
26	840-1620	M6 x 20	4	Screw	Vis	Tornillo
27	391038X1	M6	4	Washer	Rondelle	Arandela



820 860 880
 TX760B TX860B

805 807 817 825 833 845 855

83001C01.1

6199042M3

1

Jan-06

Rear Fenders
Ailes Arrière
Guardabarros traseros

2 Wheel Steer
 2 Roues Directrices
 Dirección en 2 ruedas

C-83002-01.1-A

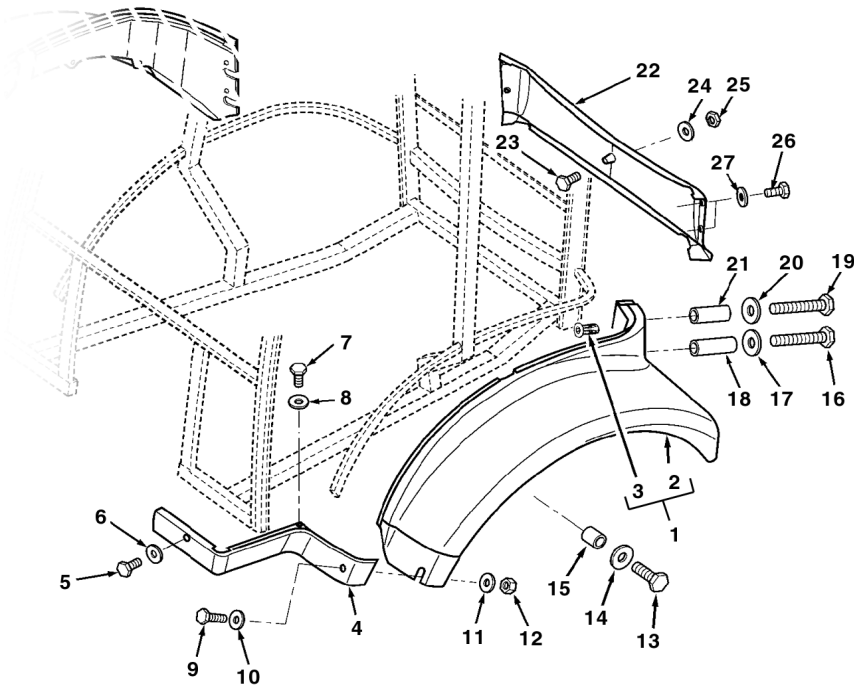

1	6101705M91	◀ Yellow	1	Fender Assy	Ensemble d'aile	Guardabarros, Conj.
1	6101706M91	▶ Yellow	1	Fender Assy	Ensemble d'aile	Guardabarros, Conj.
2		1 ▶ Ref. 1	1	Fender	Aile	Aleta
3	6101246M1	1 M6	2	Nut, Special	Ecrou Special	Tuerca especial
4	6099516M1	◀ Yellow	1	Sill	Rebord	Pieza de apoyo
4	6099517M1	▶ Yellow	1	Sill	Rebord	Pieza de apoyo
5	840-1620	M6 x 20	2	Screw	Vis	Tornillo
6	390971X1	M6	2	Washer	Rondelle	Arandela
7	6108652M1	M6 x 20	2	Screw	Vis	Tornillo
8	390972X1	M8	2	Washer	Rondelle	Arandela
9	3008229X1	M6 x 30	2	Screw	Vis	Tornillo
10	390971X1	M6	2	Washer	Rondelle	Arandela
11	6102079M1	M6	2	Washer	Rondelle	Arandela
12	1441500X1	M6	2	Nut, Lock	Écrou de blocage	Tuerca de retención
13	339009X1	M8 x 35	8	Screw	Vis	Tornillo
14	391039X1	M8	8	Washer	Rondelle	Arandela
15	6101730M1		8	Spacer	Entretoise	Traviesa
16	339891X1	M8 x 80	2	Screw	Vis	Tornillo
17	391039X1	M8	2	Washer	Rondelle	Arandela
18	6101732M2		2	Spacer	Entretoise	Traviesa
19	339891X1	M8 x 80	2	Screw	Vis	Tornillo
20	391039X1	M8	2	Washer	Rondelle	Arandela
21	6101731M2		2	Spacer	Entretoise	Traviesa
22	6099515M1	Yellow	1	Panel	Panneau	Panel
23	339804X1	M6 x 25	1	Screw	Vis	Tornillo
24	391038X1	M6	1	Washer	Rondelle	Arandela
25	1441500X1	M6	1	Nut, Lock	Écrou de blocage	Tuerca de retención
26	840-1620	M6 x 20	4	Screw	Vis	Tornillo
27	391038X1	M6	4	Washer	Rondelle	Arandela



970 980

921 931

83002C01.1

6199042M3

1

Jan-06

Rear Fenders
Ailes Arrière
Guardabarros traseros

2 Wheel Steer
 2 Roues Directrices
 Dirección en 2 ruedas

C-83003-01.1-A

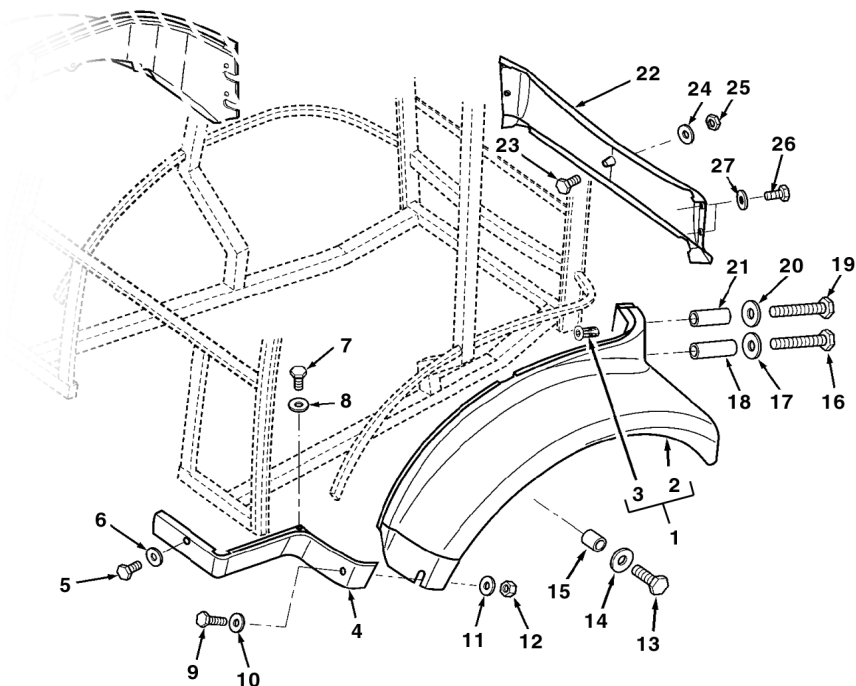

1	6101707M91	◀ Grey	1	Fender Assy	Ensemble d'aile	Guardabarros, Conj.
1	6101708M91	▶ Grey	1	Fender Assy	Ensemble d'aile	Guardabarros, Conj.
2		1 ▶ Ref. 1	1	Fender	Aile	Aleta
3	6101246M1	1 M6	2	Nut, Special	Ecrou Special	Tuerca especial
4	6099547M1	◀ Grey	1	Sill	Rebord	Pieza de apoyo
4	6099548M1	▶ Grey	1	Sill	Rebord	Pieza de apoyo
5	840-1620	M6 x 20	2	Screw	Vis	Tornillo
6	390971X1	M6	2	Washer	Rondelle	Arandela
7	6108652M1	M6 x 20	2	Screw	Vis	Tornillo
8	390972X1	M8	2	Washer	Rondelle	Arandela
9	3008229X1	M6 x 30	2	Screw	Vis	Tornillo
10	390971X1	M6	2	Washer	Rondelle	Arandela
11	6102079M1	M6	2	Washer	Rondelle	Arandela
12	1441500X1	M6	2	Nut, Lock	Écrou de blocage	Tuerca de retención
13	339009X1	M8 x 35	8	Screw	Vis	Tornillo
14	391039X1	M8	8	Washer	Rondelle	Arandela
15	6101730M1		8	Spacer	Entretoise	Traviesa
16	339891X1	M8 x 80	2	Screw	Vis	Tornillo
17	391039X1	M8	2	Washer	Rondelle	Arandela
18	6101732M2		2	Spacer	Entretoise	Traviesa
19	339891X1	M8 x 80	2	Screw	Vis	Tornillo
20	391039X1	M8	2	Washer	Rondelle	Arandela
21	6101731M2		2	Spacer	Entretoise	Traviesa
22	6099557M1	Grey	1	Panel	Panneau	Panel
23	339804X1	M6 x 25	1	Screw	Vis	Tornillo
24	391038X1	M6	1	Washer	Rondelle	Arandela
25	1441500X1	M6	1	Nut, Lock	Écrou de blocage	Tuerca de retención
26	840-1620	M6 x 20	4	Screw	Vis	Tornillo
27	391038X1	M6	4	Washer	Rondelle	Arandela



970 980

921 931

83003C01.1

6199042M3

1

Jan-06

Rear Fenders
Ailes Arrière
Guardabarros traseros

2 Wheel Steer
 2 Roues Directrices
 Dirección en 2 ruedas

C-83004-01.1-A

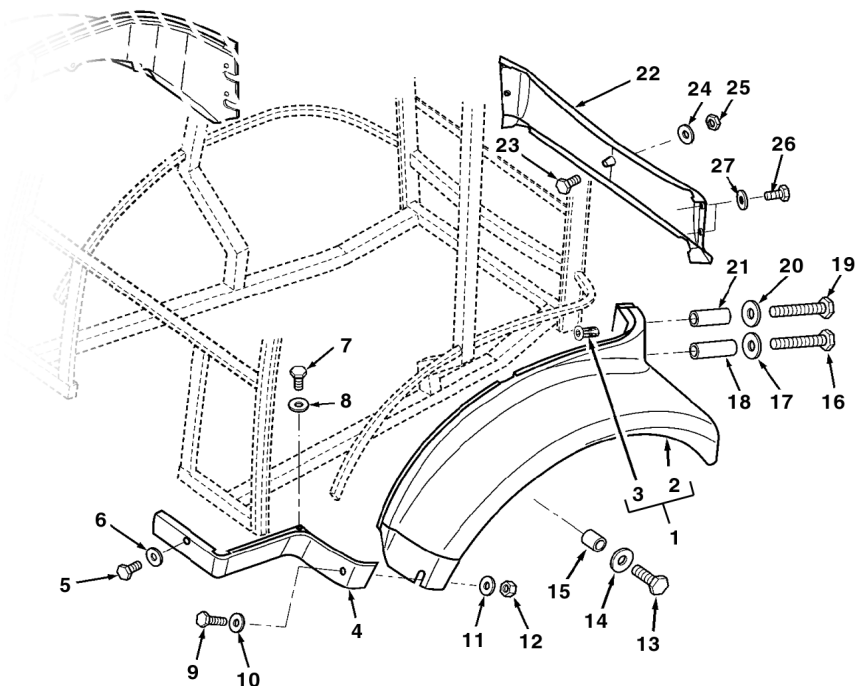

1	6101780M91	◀ Yellow	1	Fender Assy	Ensemble d'aile	Guardabarros, Conj.
1	6101781M91	▶ Yellow	1	Fender Assy	Ensemble d'aile	Guardabarros, Conj.
2		1 ▶ Ref. 1	1	Fender	Aile	Aleta
3	6101246M1	1 M6	2	Nut, Special	Ecrou Special	Tuerca especial
4	6099516M1	◀ Yellow	1	Sill	Rebord	Pieza de apoyo
4	6099517M1	▶ Yellow	1	Sill	Rebord	Pieza de apoyo
5	840-1620	M6 x 20	2	Screw	Vis	Tornillo
6	390971X1	M6	2	Washer	Rondelle	Arandela
7	6108652M1	M6 x 20	2	Screw	Vis	Tornillo
8	390972X1	M8	2	Washer	Rondelle	Arandela
9	3008229X1	M6 x 30	2	Screw	Vis	Tornillo
10	390971X1	M6	2	Washer	Rondelle	Arandela
11	6102079M1	M6	2	Washer	Rondelle	Arandela
12	1441500X1	M6	2	Nut, Lock	Écrou de blocage	Tuerca de retención
13	339009X1	M8 x 35	8	Screw	Vis	Tornillo
14	391039X1	M8	8	Washer	Rondelle	Arandela
15	6101730M1		8	Spacer	Entretoise	Traviesa
16	339891X1	M8 x 80	2	Screw	Vis	Tornillo
17	391039X1	M8	2	Washer	Rondelle	Arandela
18	6101732M2		2	Spacer	Entretoise	Traviesa
19	339891X1	M8 x 80	2	Screw	Vis	Tornillo
20	391039X1	M8	2	Washer	Rondelle	Arandela
21	6101731M2		2	Spacer	Entretoise	Traviesa
22	6099515M1	Yellow	1	Panel	Panneau	Panel
23	339804X1	M6 x 25	1	Screw	Vis	Tornillo
24	391038X1	M6	1	Washer	Rondelle	Arandela
25	1441500X1	M6	1	Nut, Lock	Écrou de blocage	Tuerca de retención
26	840-1620	M6 x 20	4	Screw	Vis	Tornillo
27	391038X1	M6	4	Washer	Rondelle	Arandela



820 860 880
 TX760B TX860B
 TX870B

801 803 813 815 821 823 831 841 843 851 853

83004C01.1

6199042M3

1

Jan-06

Rear Fenders
Ailes Arrière
Guardabarros traseros

2 Wheel Steer
 2 Roues Directrices
 Dirección en 2 ruedas

C-83005-01.1-A

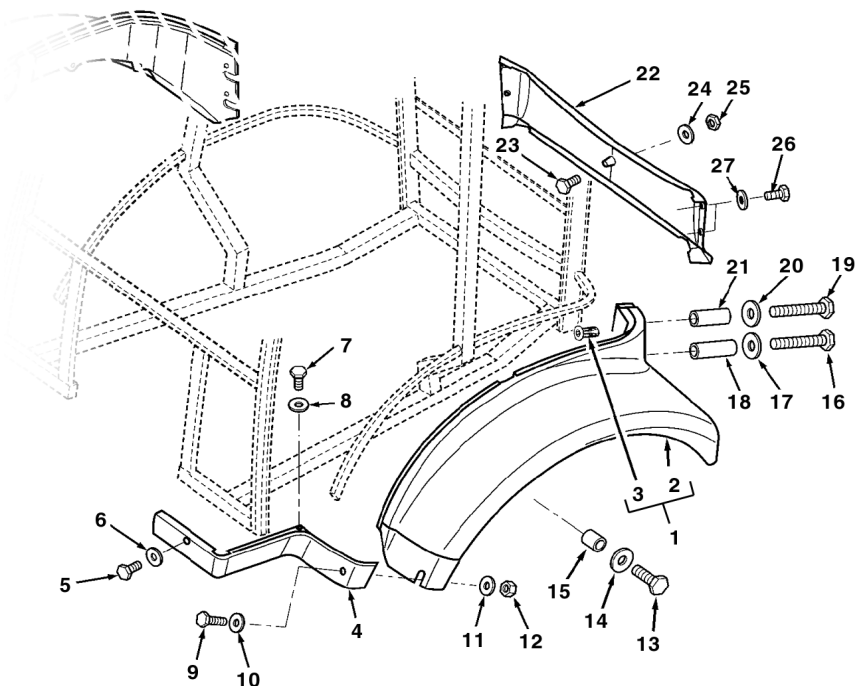

1	6101705M91	◀ Yellow	1	Fender Assy	Ensemble d'aile	Guardabarros, Conj.
1	6101706M91	▶ Yellow	1	Fender Assy	Ensemble d'aile	Guardabarros, Conj.
2		1 ▶ Ref. 1	1	Fender	Aile	Aleta
3	6101246M1	1 M6	2	Nut, Special	Ecrou Special	Tuerca especial
4	6099516M1	◀ Yellow	1	Sill	Rebord	Pieza de apoyo
4	6099517M1	▶ Yellow	1	Sill	Rebord	Pieza de apoyo
5	840-1620	M6 x 20	2	Screw	Vis	Tornillo
6	390971X1	M6	2	Washer	Rondelle	Arandela
7	6108652M1	M6 x 20	2	Screw	Vis	Tornillo
8	390972X1	M8	2	Washer	Rondelle	Arandela
9	3008229X1	M6 x 30	2	Screw	Vis	Tornillo
10	390971X1	M6	2	Washer	Rondelle	Arandela
11	6102079M1	M6	2	Washer	Rondelle	Arandela
12	1441500X1	M6	2	Nut, Lock	Écrou de blocage	Tuerca de retención
13	339009X1	M8 x 35	8	Screw	Vis	Tornillo
14	391039X1	M8	8	Washer	Rondelle	Arandela
15	6101730M1		8	Spacer	Entretoise	Traviesa
16	339891X1	M8 x 80	2	Screw	Vis	Tornillo
17	391039X1	M8	2	Washer	Rondelle	Arandela
18	6101732M2		2	Spacer	Entretoise	Traviesa
19	339891X1	M8 x 80	2	Screw	Vis	Tornillo
20	391039X1	M8	2	Washer	Rondelle	Arandela
21	6101731M2		2	Spacer	Entretoise	Traviesa
22	6099515M1	Yellow	1	Panel	Panneau	Panel
23	339804X1	M6 x 25	1	Screw	Vis	Tornillo
24	391038X1	M6	1	Washer	Rondelle	Arandela
25	1441500X1	M6	1	Nut, Lock	Écrou de blocage	Tuerca de retención
26	840-1620	M6 x 20	4	Screw	Vis	Tornillo
27	391038X1	M6	4	Washer	Rondelle	Arandela



970 980
 TX970B

922 923 932

83005C01.1

6199042M3

1

Jan-06

Rear Fenders
Ailes Arrière
Guardabarros traseros

2 Wheel Steer
 2 Roues Directrices
 Dirección en 2 ruedas

C-83006-01.1-A

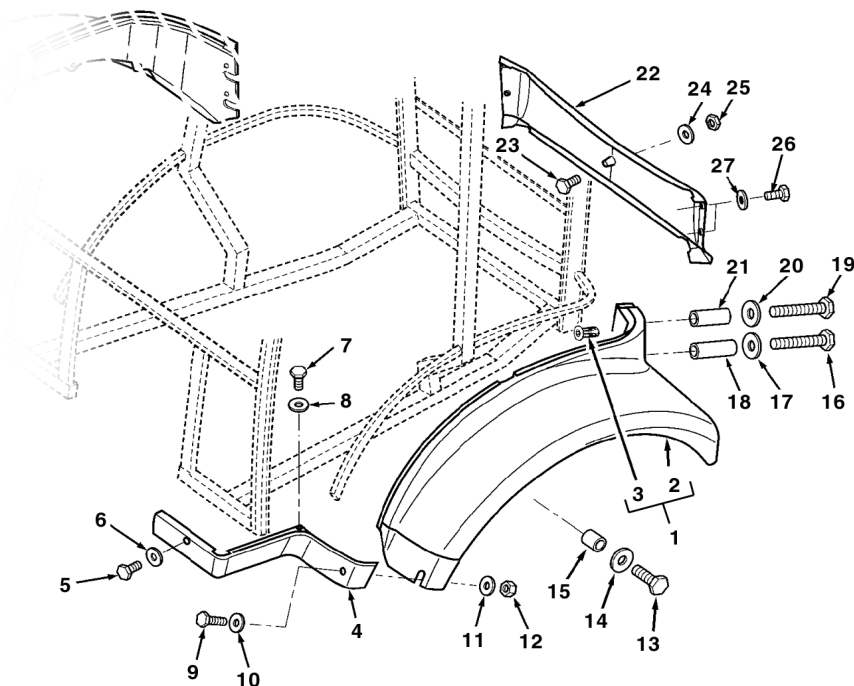

1	6101707M91	◀ Grey	1	Fender Assy	Ensemble d'aile	Guardabarros, Conj.
1	6101708M91	▶ Grey	1	Fender Assy	Ensemble d'aile	Guardabarros, Conj.
2		1 Ref. 1	1	Fender	Aile	Aleta
3	6101246M1	1 M6	2	Nut, Special	Ecrou Special	Tuerca especial
4	6099547M1	◀ Grey	1	Sill	Rebord	Pieza de apoyo
4	6099548M1	▶ Grey	1	Sill	Rebord	Pieza de apoyo
5	840-1620	M6 x 20	2	Screw	Vis	Tornillo
6	390971X1	M6	2	Washer	Rondelle	Arandela
7	6108652M1	M6 x 20	2	Screw	Vis	Tornillo
8	390972X1	M8	2	Washer	Rondelle	Arandela
9	3008229X1	M6 x 30	2	Screw	Vis	Tornillo
10	390971X1	M6	2	Washer	Rondelle	Arandela
11	6102079M1	M6	2	Washer	Rondelle	Arandela
12	1441500X1	M6	2	Nut, Lock	Écrou de blocage	Tuerca de retención
13	339009X1	M8 x 35	8	Screw	Vis	Tornillo
14	391039X1	M8	8	Washer	Rondelle	Arandela
15	6101730M1		8	Spacer	Entretoise	Traviesa
16	339891X1	M8 x 80	2	Screw	Vis	Tornillo
17	391039X1	M8	2	Washer	Rondelle	Arandela
18	6101732M2		2	Spacer	Entretoise	Traviesa
19	339891X1	M8 x 80	2	Screw	Vis	Tornillo
20	391039X1	M8	2	Washer	Rondelle	Arandela
21	6101731M2		2	Spacer	Entretoise	Traviesa
22	6099557M1	Grey	1	Panel	Panneau	Panel
23	339804X1	M6 x 25	1	Screw	Vis	Tornillo
24	391038X1	M6	1	Washer	Rondelle	Arandela
25	1441500X1	M6	1	Nut, Lock	Écrou de blocage	Tuerca de retención
26	840-1620	M6 x 20	4	Screw	Vis	Tornillo
27	391038X1	M6	4	Washer	Rondelle	Arandela



970 980
 TX970B

922 923 932

83006C01.1

6199042M3

1

Jan-06

Rear Fenders
Ailes Arrière
Guardabarros traseros

2 Wheel Steer
 2 Roues Directrices
 Dirección en 2 ruedas

C-83007-01.1-A

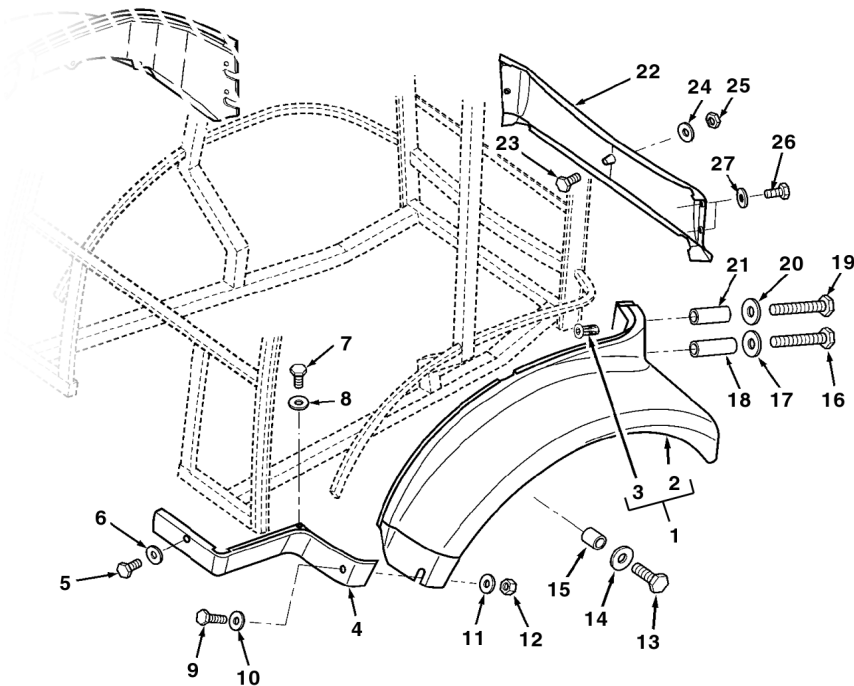

1	6107970M91	◀ Grey	1	Fender Assy	Ensemble d'aile	Guardabarros, Conj.
1	6107968M91	▶ Grey	1	Fender Assy	Ensemble d'aile	Guardabarros, Conj.
2		1 ▶ Ref. 1	1	Fender	Aile	Aleta
3	6101246M1	1 M6	2	Nut, Special	Ecrou Special	Tuerca especial
4	6099547M1	◀ Grey	1	Sill	Rebord	Pieza de apoyo
4	6099548M1	▶ Grey	1	Sill	Rebord	Pieza de apoyo
5	840-1620	M6 x 20	2	Screw	Vis	Tornillo
6	390971X1	M6	2	Washer	Rondelle	Arandela
7	6108652M1	M6 x 20	2	Screw	Vis	Tornillo
8	390972X1	M8	2	Washer	Rondelle	Arandela
9	3008229X1	M6 x 30	2	Screw	Vis	Tornillo
10	390971X1	M6	2	Washer	Rondelle	Arandela
11	6102079M1	M6	2	Washer	Rondelle	Arandela
12	1441500X1	M6	2	Nut, Lock	Écrou de blocage	Tuerca de retención
13	339009X1	M8 x 35	8	Screw	Vis	Tornillo
14	391039X1	M8	8	Washer	Rondelle	Arandela
15	6101730M1		8	Spacer	Entretoise	Traviesa
16	339891X1	M8 x 80	2	Screw	Vis	Tornillo
17	391039X1	M8	2	Washer	Rondelle	Arandela
18	6101732M2		2	Spacer	Entretoise	Traviesa
19	339891X1	M8 x 80	2	Screw	Vis	Tornillo
20	391039X1	M8	2	Washer	Rondelle	Arandela
21	6101731M2		2	Spacer	Entretoise	Traviesa
22	6099557M1	Grey	1	Panel	Panneau	Panel
23	339804X1	M6 x 25	1	Screw	Vis	Tornillo
24	391038X1	M6	1	Washer	Rondelle	Arandela
25	1441500X1	M6	1	Nut, Lock	Écrou de blocage	Tuerca de retención
26	840-1620	M6 x 20	4	Screw	Vis	Tornillo
27	391038X1	M6	4	Washer	Rondelle	Arandela



820 860 880
 TX760B TX860B
 TX870B

801 803 809 811 813 815 821 823 831 841 843 851 853

83007C01.1

6199042M3

1

Jan-06

Rear Fenders
Ailes Arrière
Guardabarros traseros

2 Wheel Steer
 2 Roues Directrices
 Dirección en 2 ruedas

C-83008-01.1-A

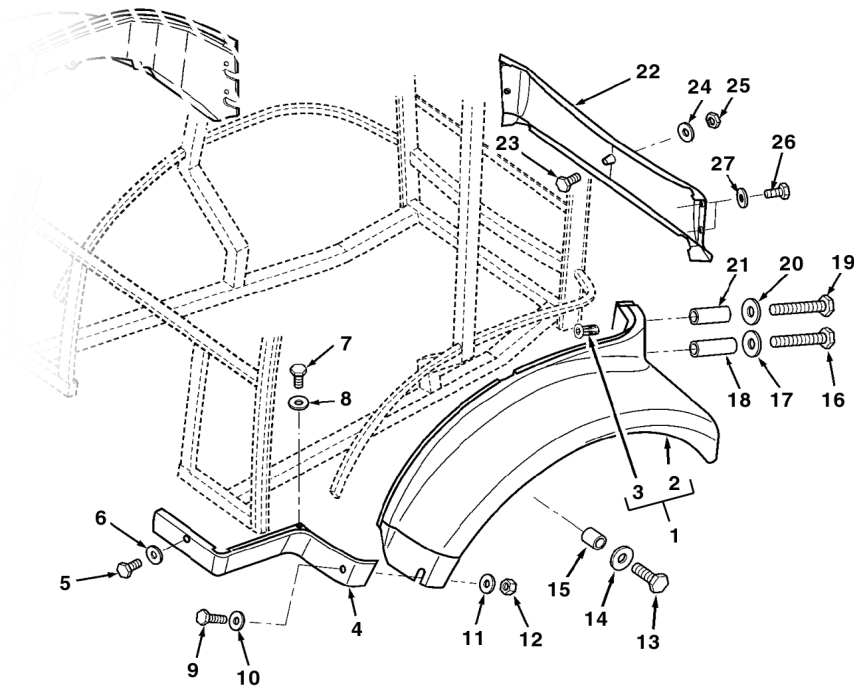

1	6107970M91	◀ Grey	1	Fender Assy	Ensemble d'aile	Guardabarros, Conj.
1	6107968M91	▶ Grey	1	Fender Assy	Ensemble d'aile	Guardabarros, Conj.
2		1 ▶ Ref. 1	1	Fender	Aile	Aleta
3	6101246M1	1 M6	2	Nut, Special	Ecrou Special	Tuerca especial
4	6099547M1	◀ Grey	1	Sill	Rebord	Pieza de apoyo
4	6099548M1	▶ Grey	1	Sill	Rebord	Pieza de apoyo
5	840-1620	M6 x 20	2	Screw	Vis	Tornillo
6	390971X1	M6	2	Washer	Rondelle	Arandela
7	6108652M1	M6 x 20	2	Screw	Vis	Tornillo
8	390972X1	M8	2	Washer	Rondelle	Arandela
9	3008229X1	M6 x 30	2	Screw	Vis	Tornillo
10	390971X1	M6	2	Washer	Rondelle	Arandela
11	6102079M1	M6	2	Washer	Rondelle	Arandela
12	1441500X1	M6	2	Nut, Lock	Écrou de blocage	Tuerca de retención
13	339009X1	M8 x 35	8	Screw	Vis	Tornillo
14	391039X1	M8	8	Washer	Rondelle	Arandela
15	6101730M1		8	Spacer	Entretoise	Traviesa
16	339891X1	M8 x 80	2	Screw	Vis	Tornillo
17	391039X1	M8	2	Washer	Rondelle	Arandela
18	6101732M2		2	Spacer	Entretoise	Traviesa
19	339891X1	M8 x 80	2	Screw	Vis	Tornillo
20	391039X1	M8	2	Washer	Rondelle	Arandela
21	6101731M2		2	Spacer	Entretoise	Traviesa
22	6099557M1	Grey	1	Panel	Panneau	Panel
23	339804X1	M6 x 25	1	Screw	Vis	Tornillo
24	391038X1	M6	1	Washer	Rondelle	Arandela
25	1441500X1	M6	1	Nut, Lock	Écrou de blocage	Tuerca de retención
26	840-1620	M6 x 20	4	Screw	Vis	Tornillo
27	391038X1	M6	4	Washer	Rondelle	Arandela



820 860 880
 TX760B TX860B

805 807 817 825 833 845 855

83008C01.1

6199042M3

1

Jan-06

Rear Fenders
Ailes Arrière
Guardabarras traseros

4 Post ROPS
 4 Poteau ROPS
 4 poste ROPS

Narrow
 Narrow
 Narrow

C-83009-01.1-A

1	6109034M1	◀	1	Fender	Aile	Aleta
1	6109035M1	▶	1	Fender	Aile	Aleta
2	339124X1	M8 x 16	12	Screw	Vis	Tornillo
3	391039X1	M8	12	Washer	Rondelle	Arandela

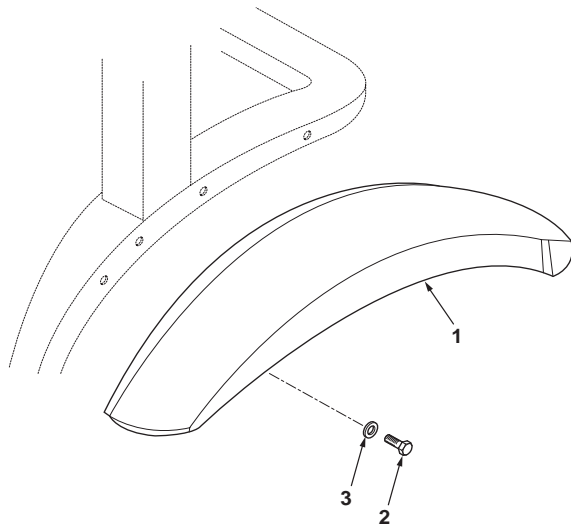

820 860 880
 TX760B TX860B
 TX870B

802 804 806 808 810 812 814 816 822 824 832 834 842 844 852 854

83009C01.1

6199042M3

1

Jan-06

Rear Fenders
Ailes Arrière
Guardabarras traseros

4 Post ROPS
 4 Poteau ROPS
 4 poste ROPS

Wide
 Wide
 Wide

C-83010-01.1-A

1	6109036M1	◀	1	Fender	Aile	Aleta
1	6109037M1	▶	1	Fender	Aile	Aleta
2	339124X1	M8 x 16	12	Screw	Vis	Tornillo
3	391039X1	M8	12	Washer	Rondelle	Arandela

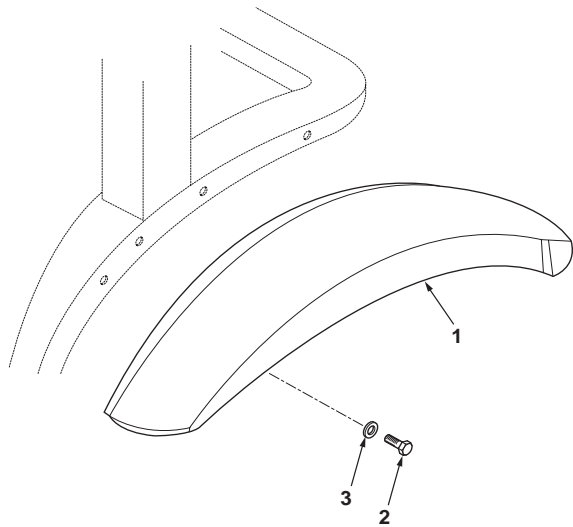

820 860 880
 TX760B TX860B
 TX870B

802 804 806 808 814 816 822 824 832 834 842 844 852 854

83010C01.1

6199042M3

1

Jan-06

Rear Fenders
Ailes Arrière
Guardabarras traseros

Sideshift Mudguard
Garde-boue Tablier de Déplacement Latéral
Laterales

C-83001-02.1-A

1	6109661M1	◀	1	Deflector, Mud	Garde-boue	Guardafango
1	6109662M1	▶	1	Deflector, Mud	Garde-boue	Guardafango
2	339124X1	M8 x 16	8	Screw	Vis	Tornillo
3	390972X1	M8	8	Washer	Rondelle	Arandela
4	6101892M1		8	Spacer	Entretoise	Travesa
5	390735X1	M12	8	Washer	Rondelle	Arandela

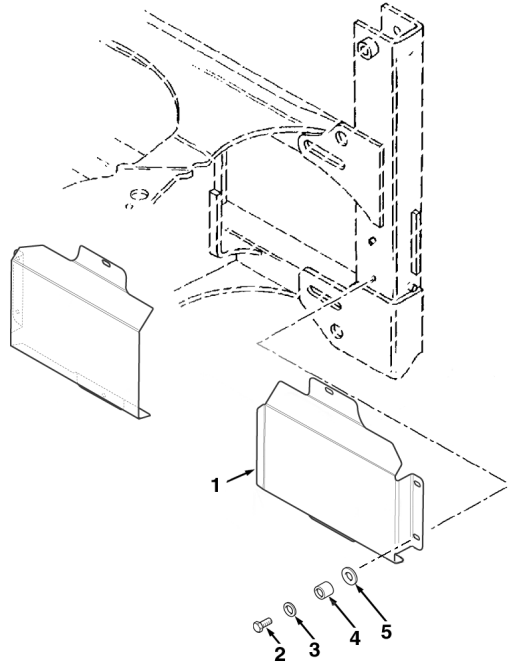

820 860 880
TX760B TX860B

805 807 817 825 833 845 855

83001C02.1

6199042M3

1

Jan-06

Rear Fenders
Ailes Arrière
Guardabarras traseros

Sideshift Mudguard
Garde-boue Tablier de Déplacement Latéral
Laterales

C-83002-02.1-A

1	6109661M1	◀	1	Deflector, Mud	Garde-boue	Guardafango
1	6109662M1	▶	1	Deflector, Mud	Garde-boue	Guardafango
2	339124X1	M8 x 16	8	Screw	Vis	Tornillo
3	390972X1	M8	8	Washer	Rondelle	Arandela
4	6101892M1		8	Spacer	Entretoise	Travesa
5	390735X1	M12	8	Washer	Rondelle	Arandela

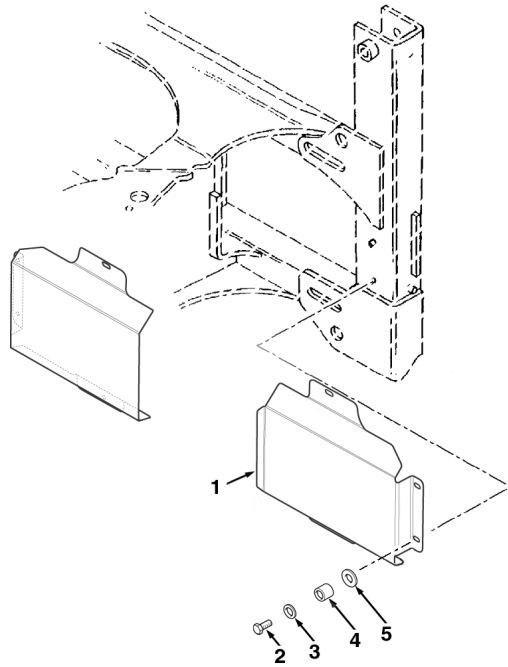

970 980

921 931

83002C02.1

6199042M3

1

Jan-06

Rear Fenders
Ailes Arrière
Guardabarras traseros

Sideshift Mudguard
Garde-boue Tablier de Déplacement Latéral
Laterales

C-83003-02.1-A

1	6109661M1	◀	1	Deflector, Mud	Garde-boue	Guardafango
1	6109662M1	▶	1	Deflector, Mud	Garde-boue	Guardafango
2	339124X1	M8 x 16	8	Screw	Vis	Tornillo
3	390972X1	M8	8	Washer	Rondelle	Arandela
4	6101892M1		8	Spacer	Entretoise	Traviesa
5	390735X1	M12	8	Washer	Rondelle	Arandela

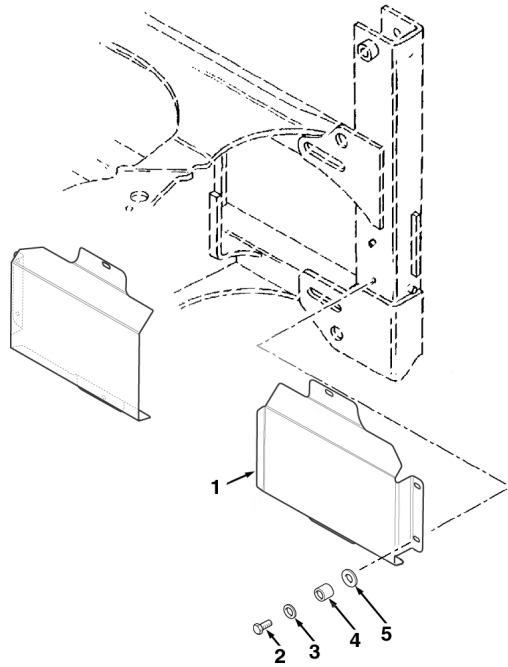

970 980

921 931

83003C02.1

6199042M3

1

Jan-06

Rear Fenders
Ailes Arrière
Guardabarras traseros

Sideshift Mudguard
Garde-boue Tablier de Déplacement Latéral
Laterales

C-83008-02.1-A

1	6109661M1	◀	1	Deflector, Mud	Garde-boue	Guardafango
1	6109662M1	▶	1	Deflector, Mud	Garde-boue	Guardafango
2	339124X1	M8 x 16	8	Screw	Vis	Tornillo
3	390972X1	M8	8	Washer	Rondelle	Arandela
4	6101892M1		8	Spacer	Entretoise	Travesa
5	390735X1	M12	8	Washer	Rondelle	Arandela

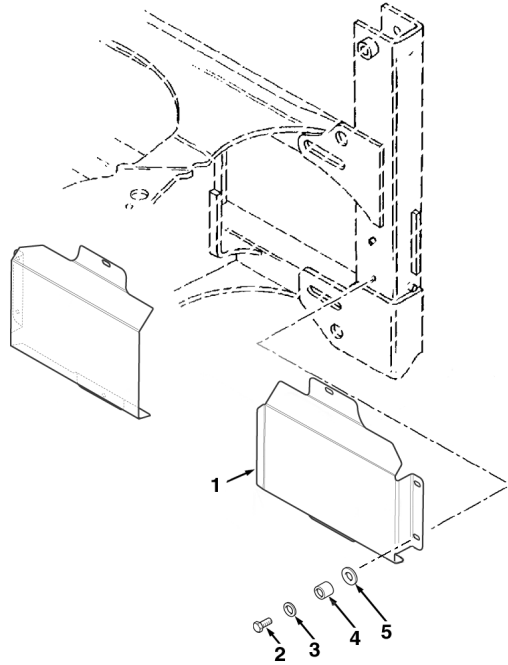

820 860 880
TX760B TX860B

805 807 817 825 833 845 855

83008C02.1

6199042M3

1

Jan-06

L - Front Axle and Steer System • Essieu avant et direction • Eje delantero y sistema de dirección

Front Axle - Differential.....	16011C03.1	Pont Avant - Différentiel	Puente delantero - Diferencial
Front Axle - Differential.....	16011C04.1	Pont Avant - Différentiel	Puente delantero - Diferencial
Front Axle - Differential.....	16012C03.1	Pont Avant - Différentiel	Puente delantero - Diferencial
Front Axle - Differential.....	16012C04.1	Pont Avant - Différentiel	Puente delantero - Diferencial
Front Axle - Differential.....	16013C03.1	Pont Avant - Différentiel	Puente delantero - Diferencial
Front Axle - Differential.....	16013C04.1	Pont Avant - Différentiel	Puente delantero - Diferencial
Front Axle - Differential.....	16014C03.1	Pont Avant - Différentiel	Puente delantero - Diferencial
Front Axle - Differential.....	16014C04.1	Pont Avant - Différentiel	Puente delantero - Diferencial
Front Axle - Drive Shaft.....	16011C06.1	Pont Avant - Arbre d'entraînement	Eje delantero - Árbol de arrastre
Front Axle - Drive Shaft.....	16012C06.1	Pont Avant - Arbre d'entraînement	Eje delantero - Árbol de arrastre
Front Axle - Drive Shaft.....	16013C06.1	Pont Avant - Arbre d'entraînement	Eje delantero - Árbol de arrastre
Front Axle - Drive Shaft.....	16014C06.1	Pont Avant - Arbre d'entraînement	Eje delantero - Árbol de arrastre
Front Axle - Housing.....	16010C02.1	Pont Avant - Carter	Puente delantero - Alojamiento
Front Axle - Housing.....	16011C02.1	Pont Avant - Carter	Puente delantero - Alojamiento
Front Axle - Housing.....	16012C02.1	Pont Avant - Carter	Puente delantero - Alojamiento
Front Axle - Housing.....	16013C02.1	Pont Avant - Carter	Puente delantero - Alojamiento
Front Axle - Housing.....	16014C02.1	Pont Avant - Carter	Puente delantero - Alojamiento
Front Axle - Installation.....	16010C01.1	Pont Avant - Montage	Puente delantero - Instalación
Front Axle - Installation.....	16011C01.1	Pont Avant - Montage	Puente delantero - Instalación
Front Axle - Installation.....	16012C01.1	Pont Avant - Montage	Puente delantero - Instalación
Front Axle - Installation.....	16013C01.1	Pont Avant - Montage	Puente delantero - Instalación
Front Axle - Installation.....	16014C01.1	Pont Avant - Montage	Puente delantero - Instalación
Front Axle - Installation.....	16015C01.1	Pont Avant - Montage	Puente delantero - Instalación
Front Axle - Installation.....	16015C02.1	Pont Avant - Montage	Puente delantero - Instalación
Front Axle - Installation.....	16015C03.1	Pont Avant - Montage	Puente delantero - Instalación
Front Axle - Installation.....	16015C04.1	Pont Avant - Montage	Puente delantero - Instalación
Front Axle - Installation.....	16015C05.1	Pont Avant - Montage	Puente delantero - Instalación
Front Axle - Installation.....	16015C06.1	Pont Avant - Montage	Puente delantero - Instalación
Front Axle - Installation.....	16015C07.1	Pont Avant - Montage	Puente delantero - Instalación
Front Axle - Installation.....	16016C01.1	Pont Avant - Montage	Puente delantero - Instalación
Front Axle - Installation.....	16016C02.1	Pont Avant - Montage	Puente delantero - Instalación
Front Axle - Installation.....	16016C03.1	Pont Avant - Montage	Puente delantero - Instalación
Front Axle - Installation.....	16016C04.1	Pont Avant - Montage	Puente delantero - Instalación
Front Axle - Installation.....	16016C05.1	Pont Avant - Montage	Puente delantero - Instalación
Front Axle - Installation.....	16016C06.1	Pont Avant - Montage	Puente delantero - Instalación
Front Axle - Installation.....	16016C07.1	Pont Avant - Montage	Puente delantero - Instalación
Front Axle - Steering Pivot.....	16010C03.1	Pont Avant - Pivot de Direction	Puente delantero - Pivote de dirección
Front Axle - Steering Pivot.....	16011C05.1	Pont Avant - Pivot de Direction	Puente delantero - Pivote de dirección



L - Front Axle and Steer System • Essieu avant et direction • Eje delantero y sistema de dirección

Front Axle - Steering Pivot.....	16012C05.1	Pont Avant - Pivot de Direction	Puente delantero - Pivote de dirección
Front Axle - Steering Pivot.....	16013C05.1	Pont Avant - Pivot de Direction	Puente delantero - Pivote de dirección
Front Axle - Steering Pivot.....	16014C05.1	Pont Avant - Pivot de Direction	Puente delantero - Pivote de dirección
Front Axle - Wheel Hub	16010C04.1	Pont Avant - Moyeu de Roue	Puente delantero - Cubo de rueda
Front Axle - Wheel Hub	16011C07.1	Pont Avant - Moyeu de Roue	Puente delantero - Cubo de rueda
Front Axle - Wheel Hub	16012C07.1	Pont Avant - Moyeu de Roue	Puente delantero - Cubo de rueda
Front Axle - Wheel Hub	16013C07.1	Pont Avant - Moyeu de Roue	Puente delantero - Cubo de rueda
Front Axle - Wheel Hub	16014C07.1	Pont Avant - Moyeu de Roue	Puente delantero - Cubo de rueda
Steering System	17001C01.1	Direction	Dirección
Steering System	17002C01.1	Direction	Dirección
Steering System	17002C02.1	Direction	Dirección



Front Axle
Pont Avant
Puente delantero

Differential
Différentiel
Diferencial

Bevel Gear - 4 Wheel Drive
Couple Conique - 4 Roues Motrices
Piñón cónico - 4 ruedas motrices

C-16011-03.1-A

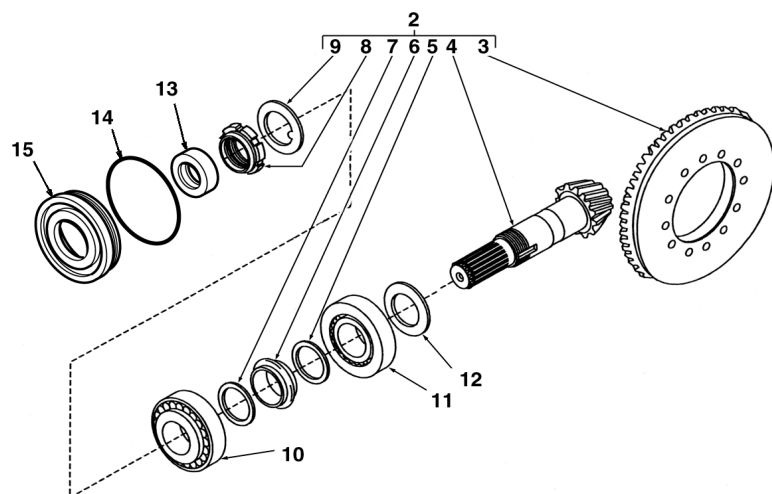

1	6109000M91		Ref: 148092	1	Axle Assy, Front	Montage d'essieu, avant	Puente delantero, Conj.
2	6193330M91	1	16/31T	1	Kit, Crownwheel	Jeu de couronnes	Juego de coronas
3		2	Ref. 2	1	Crownwheel	Couronnes	Corona
4		2	Ref. 2	1	Pinion	Pignon	Piñón
5	3523082M1	2		1	Washer	Rondelle	Arandela
6	3523083M1	2		1	Spacer	Entretoise	Travesa
7	3523082M1	2		1	Washer	Rondelle	Arandela
8	3475570M1	2	M40	1	Nut	Écrou	Tuerca
9	3475569M1	2		1	Washer, Lock	Rondelle de blocage	Arandela de freno
10	3475567M1	1		1	Bearing, Ball	Roulement à billes	Cojinete de bolas
11	3475567M1	1		1	Bearing, Ball	Roulement à billes	Cojinete de bolas
12	6190197M1	1	2,5 mm	X	Shim	Cale	Calce
12	6190198M1	1	2,6 mm	X	Shim	Cale	Calce
12	6190199M1	1	2,7 mm	X	Shim	Cale	Calce
12	6190200M1	1	2,8 mm	X	Shim	Cale	Calce
12	6190201M1	1	2,9 mm	X	Shim	Cale	Calce
12	6190202M1	1	3,0 mm	X	Shim	Cale	Calce
12	6190203M1	1	3,1 mm	X	Shim	Cale	Calce
12	6190204M1	1	3,2 mm	X	Shim	Cale	Calce
12	6190205M1	1	3,3 mm	X	Shim	Cale	Calce
12	6190206M1	1	3,4 mm	X	Shim	Cale	Calce
13	3475534M1	1	35 x 52 x 16 mm	1	Seal	Joint	Junta
14	6194006M1	1		1	O-Ring	Joint torique	Junta de tipo O
15	6194025M1	1		1	Cover	Cache	Tapa



820
TX760B

807 808 833 834

16011C03.1

6199042M3

1

Jan-06

Front Axle
Pont Avant
Puente delantero

Differential
Différentiel
Diferencial

4 Wheel Drive
4 Roues Motrices
4 ruedas motrices

C-16011-04.1-A

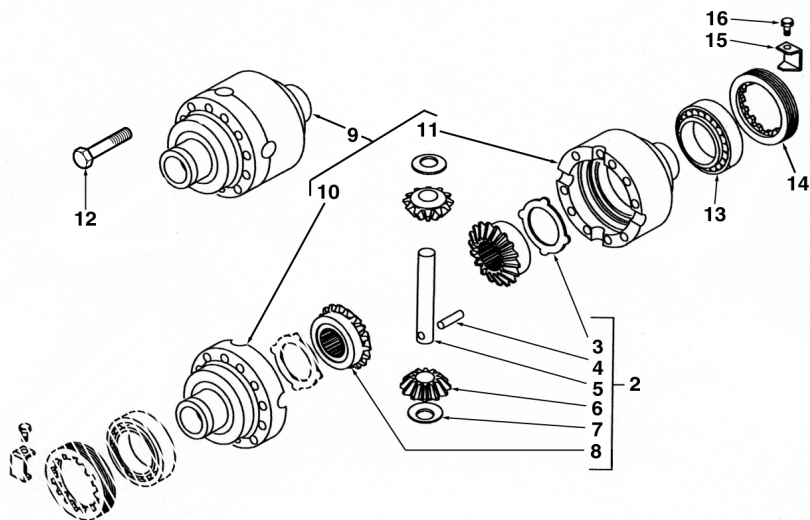

1	6109000M91		Continued Ref: 148092	1	Axle Assy, Front	Montage d'essieu, avant	Puente delantero, Conj.
2	6190225M91	1		1	Kit, Differential	Jeu, différentiel	Juego, Diferencial
3	3475581M1	2		2	Washer, Thrust	Rondelle de butée	Arandela de tope
4	3523088M1	2		1	Pin, Dowel	Goupille position.	Peón
5	3523085M1	2		1	Shaft	Arbre	Árbol
6		2	Ref. 2	2	Gear	Pignon	Piñón
7	3475579M1	2		2	Washer, Thrust	Rondelle de butée	Arandela de tope
8		2	Ref. 2	2	Gear	Pignon	Piñón
9	6190815M91	1		1	Housing Assy	Ensemble de carter	Cárter, Conj.
10		9	Ref. 9	1	Housing	Carter	Cárter
11		9	Ref. 9	1	Housing	Carter	Cárter
12	3523086M1	1	M10 x 75	12	Screw	Vis	Tornillo
13	3475585M1	1		2	Bearing, Roller	Rouleau de roulement	Cojinete, Rodillos
14	3475584M1	1		2	Nut	Écrou	Tuerca
15	3475583M1	1		2	Plate	Plaque	Placa
16	3523583M1	1	M6 x 10	2	Screw	Vis	Tornillo



820
TX760B

807 808 833 834

16011C04.1

6199042M3

1

Jan-06

Front Axle
Pont Avant
Puente delantero

Differential
Différentiel
Diferencial

Bevel Gear - 4 Wheel Drive
Couple Conique - 4 Roues Motrices
Piñón cónico - 4 ruedas motrices

C-16012-03.1-A

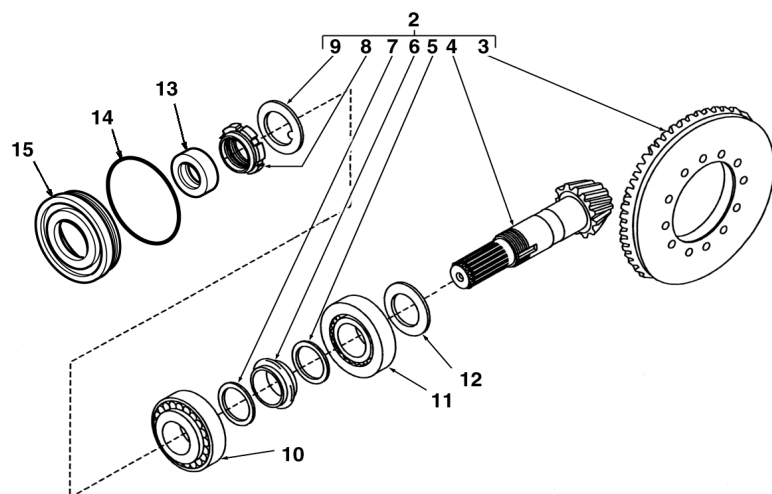

1	6109144M91		Ref: 148093	1	Axle Assy, Front	Montage d'essieu, avant	Puente delantero, Conj.
2	6193329M91	1	15/32T	1	Kit, Crownwheel	Jeu de couronnes	Juego de coronas
3		2	Ref. 2	1	Crownwheel	Couronnes	Corona
4		2	Ref. 2	1	Pinion	Pignon	Piñón
5	3523082M1	2		1	Washer	Rondelle	Arandela
6	3523083M1	2		1	Spacer	Entretoise	Travesa
7	3523082M1	2		1	Washer	Rondelle	Arandela
8	3475570M1	2	M40	1	Nut	Écrou	Tuerca
9	3475569M1	2		1	Washer, Lock	Rondelle de blocage	Arandela de freno
10	3475567M1	1		1	Bearing, Ball	Roulement à billes	Cojinete de bolas
11	3475567M1	1		1	Bearing, Ball	Roulement à billes	Cojinete de bolas
12	6190197M1	1	2,5 mm	X	Shim	Cale	Calce
12	6190198M1	1	2,6 mm	X	Shim	Cale	Calce
12	6190199M1	1	2,7 mm	X	Shim	Cale	Calce
12	6190200M1	1	2,8 mm	X	Shim	Cale	Calce
12	6190201M1	1	2,9 mm	X	Shim	Cale	Calce
12	6190202M1	1	3,0 mm	X	Shim	Cale	Calce
12	6190203M1	1	3,1 mm	X	Shim	Cale	Calce
12	6190204M1	1	3,2 mm	X	Shim	Cale	Calce
12	6190205M1	1	3,3 mm	X	Shim	Cale	Calce
12	6190206M1	1	3,4 mm	X	Shim	Cale	Calce
13	3475534M1	1	35 x 52 x 16 mm	1	Seal	Joint	Junta
14	6194006M1	1		1	O-Ring	Joint torique	Junta de tipo O
15	6194025M1	1		1	Cover	Cache	Tapa



820 860 880
TX760B TX860B
TX870B

803 804 813 814 815 816 817 831 832 841 842 843 844 845

16012C03.1

6199042M3

1

Jan-06

Front Axle
Pont Avant
Puente delantero

Differential
Différentiel
Diferencial

4 Wheel Drive
4 Roues Motrices
4 ruedas motrices

C-16012-04.1-A

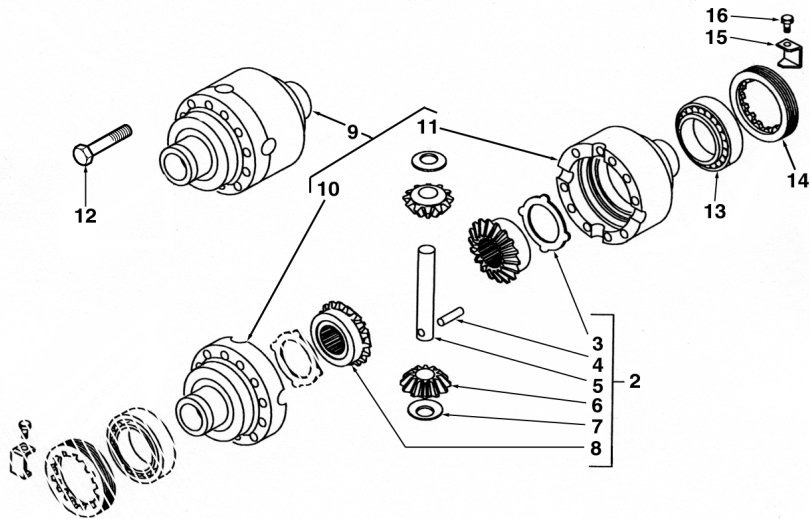

1	6109144M91		Continued Ref: 148093	1	Axle Assy, Front	Montage d'essieu, avant	Puente delantero, Conj.
2	6190225M91	1		1	Kit, Differential	Jeu, différentiel	Juego, Diferencial
3	3475581M1	2		2	Washer, Thrust	Rondelle de butée	Arandela de tope
4	3523088M1	2		1	Pin, Dowel	Goupille position.	Peón
5	3523085M1	2		1	Shaft	Arbre	Árbol
6		2	Ref. 2	2	Gear	Pignon	Piñón
7	3475579M1	2		2	Washer, Thrust	Rondelle de butée	Arandela de tope
8		2	Ref. 2	2	Gear	Pignon	Piñón
9	6190815M91	1		1	Housing Assy	Ensemble de carter	Cárter, Conj.
10		9	Ref. 9	1	Housing	Carter	Cárter
11		9	Ref. 9	1	Housing	Carter	Cárter
12	3523086M1	1	M10 x 75	12	Screw	Vis	Tornillo
13	3475585M1	1		2	Bearing, Roller	Rouleau de roulement	Cojinete, Rodillos
14	3475584M1	1		2	Nut	Écrou	Tuerca
15	3475583M1	1		2	Plate	Plaque	Placa
16	3523583M1	1	M6 x 10	2	Screw	Vis	Tornillo



820 860 880
TX760B TX860B
TX870B

803 804 813 814 815 816 817 831 832 841 842 843 844 845

16012C04.1

6199042M3

1

Jan-06

Front Axle
Pont Avant
Puente delantero

Differential
Différentiel
Diferencial

Bevel Gear - 4 Wheel Drive
Couple Conique - 4 Roues Motrices
Piñón cónico - 4 ruedas motrices

C-16013-03.1-A

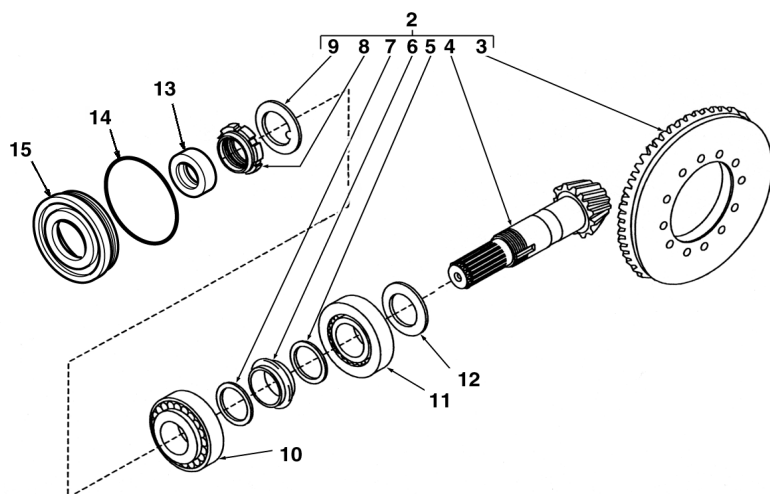

1	6109145M91		Ref: 148648	1	Axle Assy, Front	Montage d'essieu, avant	Puente delantero, Conj.
2	6194016M91	1		1	Kit, Crownwheel	Jeu de couronnes	Juego de coronas
3		2	➤ Ref. 2	1	Crownwheel	Couronnes	Corona
4		2	➤ Ref. 2	1	Pinion	Pignon	Piñón
5	3523082M1	2		1	Washer	Rondelle	Arandela
6	3523083M1	2		1	Spacer	Entretoise	Travesa
7	3523082M1	2		1	Washer	Rondelle	Arandela
8	3475570M1	2	M40	1	Nut	Écrou	Tuerca
9	3475569M1	2		1	Washer, Lock	Rondelle de blocage	Arandela de freno
10	3475567M1	1		1	Bearing, Ball	Roulement à billes	Cojinete de bolas
11	3475567M1	1		1	Bearing, Ball	Roulement à billes	Cojinete de bolas
12	6190197M1	1	2,5 mm	X	Shim	Cale	Calce
12	6190198M1	1	2,6 mm	X	Shim	Cale	Calce
12	6190199M1	1	2,7 mm	X	Shim	Cale	Calce
12	6190200M1	1	2,8 mm	X	Shim	Cale	Calce
12	6190201M1	1	2,9 mm	X	Shim	Cale	Calce
12	6190202M1	1	3,0 mm	X	Shim	Cale	Calce
12	6190203M1	1	3,1 mm	X	Shim	Cale	Calce
12	6190204M1	1	3,2 mm	X	Shim	Cale	Calce
12	6190205M1	1	3,3 mm	X	Shim	Cale	Calce
12	6190206M1	1	3,4 mm	X	Shim	Cale	Calce
13	3475534M1	1	35 x 52 x 16 mm	1	Seal	Joint	Junta
14	6194006M1	1		1	O-Ring	Joint torique	Junta de tipo O
15	6194025M1	1		1	Cover	Cache	Tapa



860 880
TX860B TX870B

821 822 823 824 825 851 852 853 854 855

16013C03.1

6199042M3

1

Jan-06

Front Axle
Pont Avant
Puente delantero

Differential
Différentiel
Diferencial

4 Wheel Drive
4 Roues Motrices
4 ruedas motrices

C-16013-04.1-A

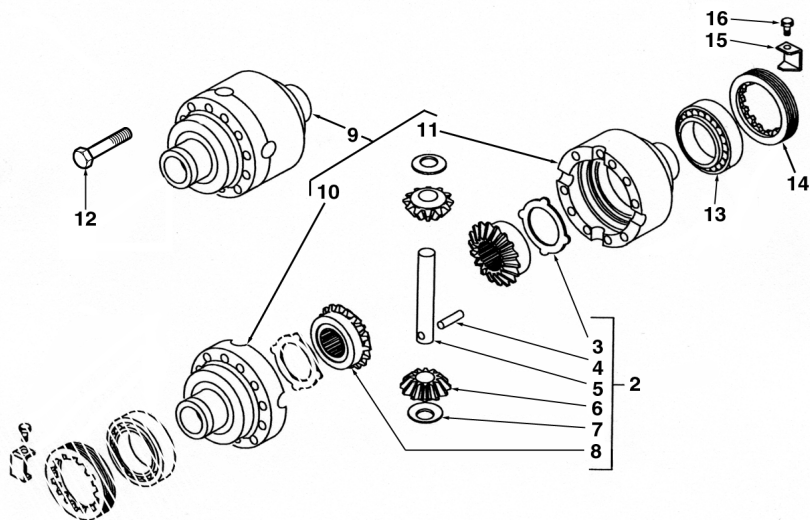

1	6109145M91		Continued Ref: 148648	1	Axle Assy, Front	Montage d'essieu, avant	Puente delantero, Conj.
2	6190225M91	1		1	Kit, Differential	Jeu, différentiel	Juego, Diferencial
3	3475581M1	2		2	Washer, Thrust	Rondelle de butée	Arandela de tope
4	3523088M1	2		1	Pin, Dowel	Goupille position.	Peón
5	3523085M1	2		1	Shaft	Arbre	Árbol
6		2	Ref. 2	2	Gear	Pignon	Piñón
7	3475579M1	2		2	Washer, Thrust	Rondelle de butée	Arandela de tope
8		2	Ref. 2	2	Gear	Pignon	Piñón
9	6190815M91	1		1	Housing Assy	Ensemble de carter	Cárter, Conj.
10		9	Ref. 9	1	Housing	Carter	Cárter
11		9	Ref. 9	1	Housing	Carter	Cárter
12	3523086M1	1	M10 x 75	12	Screw	Vis	Tornillo
13	3475585M1	1		2	Bearing, Roller	Rouleau de roulement	Cojinete, Rodillos
14	3475584M1	1		2	Nut	Écrou	Tuerca
15	3475583M1	1		2	Plate	Plaque	Placa
16	3523583M1	1	M6 x 10	2	Screw	Vis	Tornillo



860 880
TX860B TX870B

821 822 823 824 825 851 852 853 854 855

16013C04.1

6199042M3

1

Jan-06

Front Axle
Pont Avant
Puente delantero

Differential
Différentiel
Diferencial

Bevel Gear - 4 Wheel Steer
Couple Conique - 4 Roues Directrices
Piñón cónico - dirección en las 4 ruedas

C-16014-03.1-A

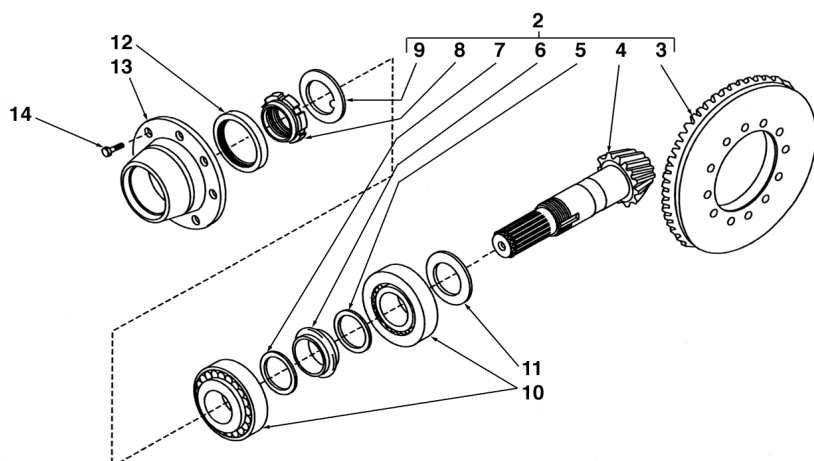

1	6109146M91		Continued Ref: 148930	1	Axle Assy, Front	Montage d'essieu, avant	Puente delantero, Conj.
2	6193437M91	1		1	Kit, Crownwheel	Jeu de couronnes	Juego de coronas
3		2	➤ Ref. 2	1	Crownwheel	Couronnes	Corona
4		2	➤ Ref. 2	1	Pinion	Pignon	Piñón
5	3523082M1	2		1	Washer	Rondelle	Arandela
6	3523083M1	2		1	Spacer	Entretoise	Travesa
7	3523082M1	2		1	Washer	Rondelle	Arandela
8	3475570M1	2	M40	1	Nut	Écrou	Tuerca
9	3475569M1	2		1	Washer, Lock	Rondelle de blocage	Arandela de freno
10	3475567M1	1		2	Bearing, Ball	Roulement à billes	Cojinete de bolas
11	6190197M1	1	2,5 mm	X	Shim	Cale	Calce
11	6190198M1	1	2,6 mm	X	Shim	Cale	Calce
11	6190199M1	1	2,7 mm	X	Shim	Cale	Calce
11	6190200M1	1	2,8 mm	X	Shim	Cale	Calce
11	6190201M1	1	2,9 mm	X	Shim	Cale	Calce
11	6190202M1	1	3,0 mm	X	Shim	Cale	Calce
11	6190203M1	1	3,1 mm	X	Shim	Cale	Calce
11	6190204M1	1	3,2 mm	X	Shim	Cale	Calce
11	6190205M1	1	3,3 mm	X	Shim	Cale	Calce
11	6190206M1	1	3,4 mm	X	Shim	Cale	Calce
12	6193433M1	1		1	Seal, Oil	Joint à huile	Junta de aceite
13	6194278M1	1		1	Flange	Flasque	Brida de unión
14	6194279M1	1	M6 x 16	6	Bolt	Boulon	Perno



970 980
 TX970B

921 922 923 931 932

16014C03.1

6199042M3

1

Jan-06

Front Axle
Pont Avant
Puente delantero

Differential
Différentiel
Diferencial

4 Wheel Steer
4 Roues Directrices
Dirección en las 4 ruedas

C-16014-04.1-A

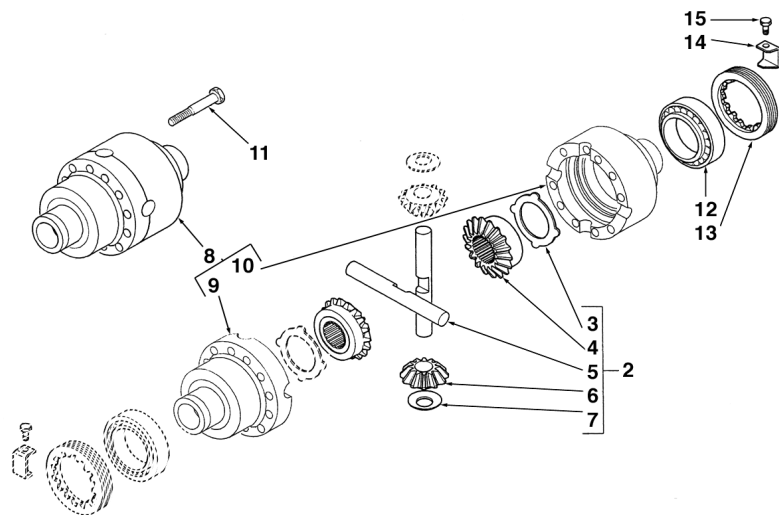

1	6109146M91		Continued Ref: 148930	1	Axle Assy, Front	Montage d'essieu, avant	Puente delantero, Conj.
2	6190257M91	1		1	Differential Assy	Ensemble différentiel	Diferencial, Conj.
3	3475581M1	2		2	Washer, Thrust	Rondelle de butée	Arandela de tope
4		2	➡ Ref. 2	2	Gear	Pignon	Piñón
5	3475577M1	2		2	Pin	Axe	Pasador
6		2	➡ Ref. 2	2	Gear	Pignon	Piñón
7	3475579M1	2		4	Washer, Thrust	Rondelle de butée	Arandela de tope
8	6190258M91	1		1	Housing Assy	Ensemble de carter	Cárter, Conj.
9		8	➡ Ref. 8	1	Housing	Carter	Cárter
10		8	➡ Ref. 8	1	Housing	Carter	Cárter
11	3523086M1	1	M10 x 75	12	Screw	Vis	Tornillo
12	3475585M1	1		2	Bearing, Roller	Rouleau de roulement	Cojinete, Rodillos
13	3475584M1	1		2	Nut	Écrou	Tuerca
14	6193373M1	1		2	Plate, Locking	Plaque d'arrêt	Placa de bloqueo
15	3523583M1	1	M6 x 10	2	Screw	Vis	Tornillo



970 980
TX970B

921 922 923 931 932

16014C04.1

6199042M3

1

Jan-06

Front Axle
Pont Avant
Eje delantero

Drive Shaft
Arbre d'entraînement
Árbol de arrastre

4 Wheel Drive
4 Roues Motrices
4 ruedas motrices

C-16011-06.1-A

1	6109000M91		Ref: 148092	1	Axle Assy, Front	Montage d'essieu, avant	Puente delantero, Conj.
2	6194032M91	1		2	Shaft, Axle	Arbre de pont	Árbol de puente
3	6194008M1	2		2	Shaft	Arbre	Árbol
4	6194009M1	2		2	Clevis	Chape	Brida
5	6194010M91	2		2	Spider Assy	Ensemble croisillon	Cruceta, Conj.
6		5	 Ref. 5	1	Spider	Croisillon	Cruceta
7	3476313M1	5		4	Ring, Snap	Anneau d'arrêt	Anillo de resorte
8	3476312M1	1		2	Shaft	Arbre	Árbol
9	3523329M1	1		2	Spacer	Entretoise	Traviesa

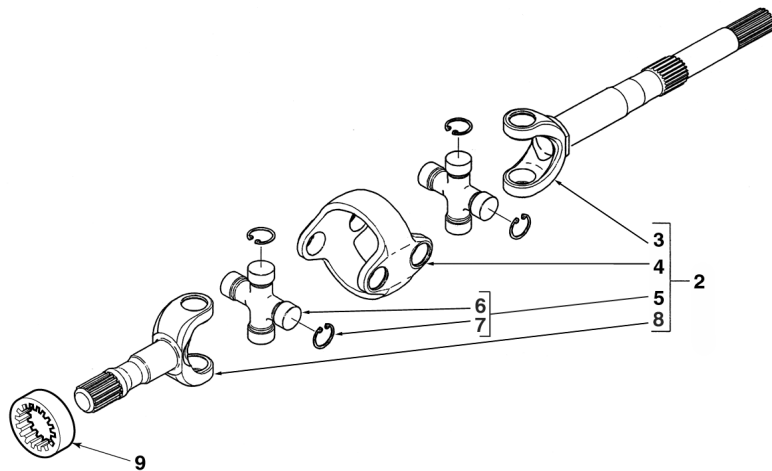

820
TX760B

807 808 833 834

16011C06.1

6199042M3

1

Jan-06

Front Axle
Pont Avant
Eje delantero

Drive Shaft
Arbre d'entraînement
Árbol de arrastre

4 Wheel Drive
4 Roues Motrices
4 ruedas motrices

C-16012-06.1-A

1	6109144M91		Ref: 148093	1	Axle Assy, Front	Montage d'essieu, avant	Puente delantero, Conj.
2	6194032M91	1		2	Shaft, Axle	Arbre de pont	Árbol de puente
3	6194008M1	2		2	Shaft	Arbre	Árbol
4	6194009M1	2		2	Clevis	Chape	Brida
5	6194010M91	2		2	Spider Assy	Ensemble croisillon	Cruceta, Conj.
6		5	 Ref. 5	1	Spider	Croisillon	Cruceta
7	3476313M1	5		4	Ring, Snap	Anneau d'arrêt	Anillo de resorte
8	3476312M1	1		2	Shaft	Arbre	Árbol
9	3523329M1	1		2	Spacer	Entretoise	Traviesa

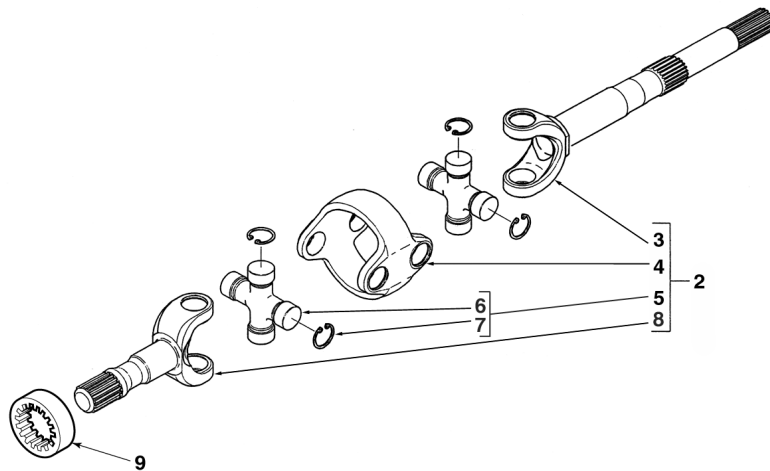

820 860 880
TX760B TX860B
TX870B

803 804 813 814 815 816 817 831 832 841 842 843 844 845

16012C06.1

6199042M3

1

Jan-06

Front Axle
Pont Avant
Eje delantero

Drive Shaft
Arbre d'entraînement
Árbol de arrastre

4 Wheel Drive
4 Roues Motrices
4 ruedas motrices

C-16013-06.1-A

1	6109145M91		Ref: 148648	1	Axle Assy, Front	Montage d'essieu, avant	Puente delantero, Conj.
2	6194032M91	1		2	Shaft, Axle	Arbre de pont	Árbol de puente
3	6194008M1	2		2	Shaft	Arbre	Árbol
4	6194009M1	2		2	Clevis	Chape	Brida
5	6194010M91	2		2	Spider Assy	Ensemble croisillon	Cruceta, Conj.
6		5	➤ Ref. 5	1	Spider	Croisillon	Cruceta
7	3476313M1	5		4	Ring, Snap	Anneau d'arrêt	Anillo de resorte
8	3476312M1	1		2	Shaft	Arbre	Árbol
9	3523329M1	1		2	Spacer	Entretoise	Traviesa

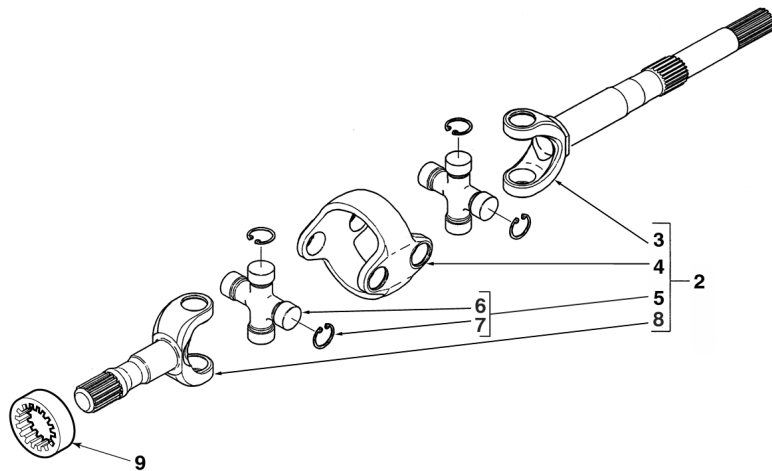

860 880
TX860B TX870B

821 822 823 824 825 851 852 853 854 855

16013C06.1

6199042M3

1

Jan-06

Front Axle
Pont Avant
Eje delantero

Drive Shaft
Arbre d'entraînement
Árbol de arrastre

4 Wheel Steer
4 Roues Directrices
Dirección en las 4 ruedas

C-16014-06.1-A

1	6109146M91		Continued Ref: 148930	1	Axle Assy, Front	Montage d'essieu, avant	Puente delantero, Conj.
2	6194280M91	1		2	Joint, Double	Joint, double	Articulación doble
3	6194281M1	2		2	Shaft	Arbre	Árbol
4	6193695M1	2		2	Yoke, Universal Joint	Chape de cardan	Yugo de cardán
5	6193696M1	2		4	Spider Assy	Ensemble croisillon	Cruceta, Conj.
6		5	 Ref. 5	4	Spider	Croisillon	Cruceta
7	6193697M1	5		16	Ring	Anneau	Aro
8	6194282M1	2		2	Shaft	Arbre	Árbol
9	6194283M1	1		2	Washer, Thrust	Rondelle de butée	Arandela de tope
10	6193438M1	1		2	Washer	Rondelle	Arandela
11	6190292M1	1	45 mm	2	Ring, Snap	Anneau d'arrêt	Anillo de resorte

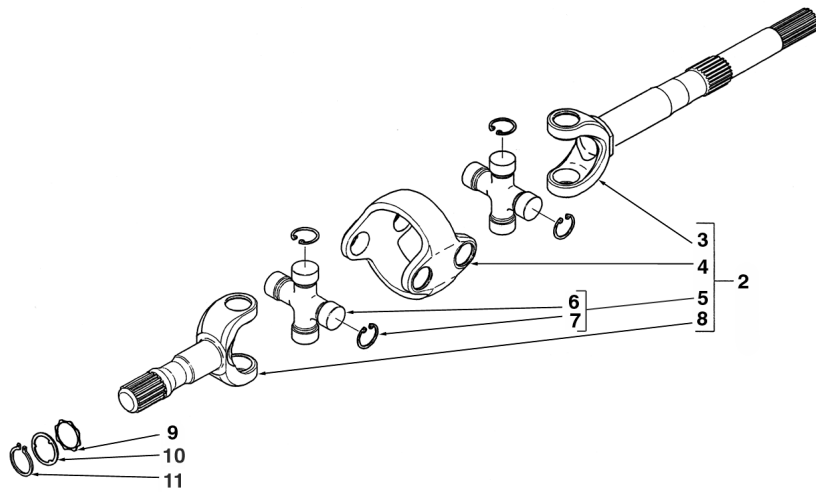

970 980
TX970B

921 922 923 931 932

16014C06.1

6199042M3

1

Jan-06

Front Axle
Pont Avant
Puente delantero

Housing
Carter
Alojamiento

2 Wheel Drive
2 Roues Motrices
2 ruedas motrices

C-16010-02.1-A

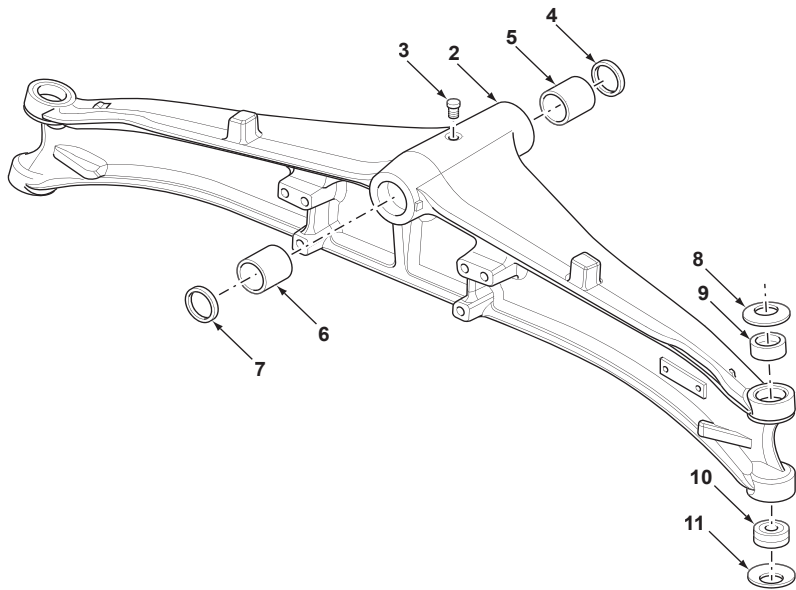

1	6109606M91		Ref: 148394	1	Axle Assy, Front	Montage d'essieu, avant	Puente delantero, Conj.
2	6194091M91	1		1	Housing, Axle	Carter de pont	Cárter de puente
3	6193344M1	1		1	Plug	Bouchon	Tapón
4	6194017M1	1		1	Seal, Oil	Joint à huile	Junta de aceite
5	6194022M1	1		1	Bush	Bague	Casquillo
6	6194021M1	1		1	Bush	Bague	Casquillo
7	6194017M1	1		1	Seal, Oil	Joint à huile	Junta de aceite
8	6194092M1	1		2	Washer, Belleville	Rondelle Belleville	Arandela de resorte
9	6194093M1	1		2	Bushing	Bague	Anillo
10	3523057M1	1		2	Bushing	Bague	Anillo
11	3523555M1	1		2	Washer	Rondelle	Arandela



820
TX760B TX860B

801 802 805 806 809 810

16010C02.1

6199042M3

1

Jan-06

Front Axle
Pont Avant
Puente delantero

Housing
Carter
Alojamiento

2 Wheel Steer
2 Roues Directrices
Dirección en 2 ruedas

C-16011-02.1-A

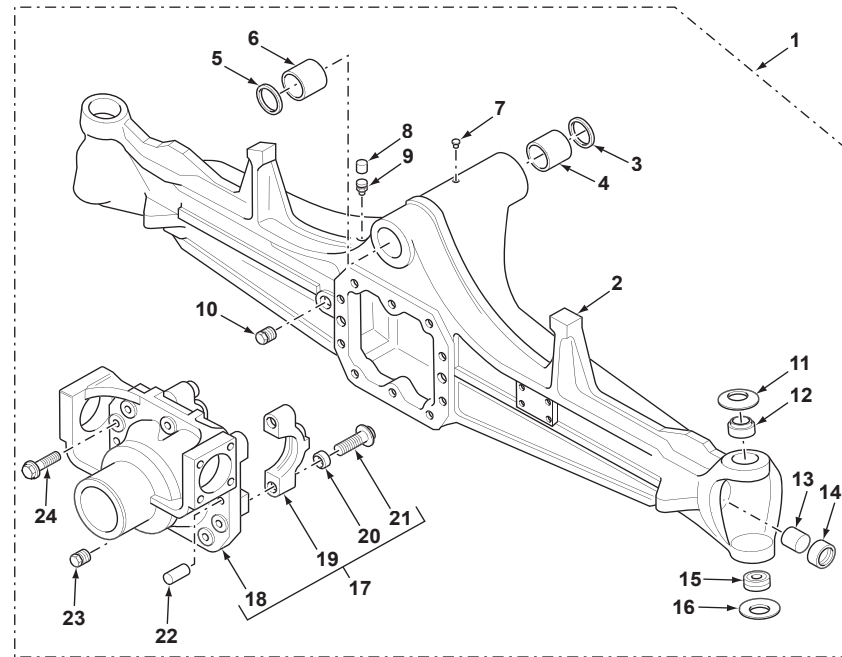

1	6109000M91		Ref: 148092	1	Axle Assy, Front	Montage d'essieu, avant	Puente delantero, Conj.
2	6194031M1	1		1	Housing, Axle	Carter de pont	Cárter de puente
3	6194017M1	1		1	Seal, Oil	Joint à huile	Junta de aceite
4	6194022M1	1		1	Bush	Bague	Casquillo
5	6194017M1	1		1	Seal, Oil	Joint à huile	Junta de aceite
6	6194021M1	1		1	Bush	Bague	Casquillo
7	6193344M1	1		1	Plug	Bouchon	Tapón
8	6194026M1	1		1	Cap	Chapeau	Sombbrero
9	3475328M1	1	M10	1	Breather	Reniflard	Ventilador del cárter
10	3475329M1	1	M22	1	Plug	Bouchon	Tapón
11	3523545M1	1		2	Washer	Rondelle	Arandela
12	6194030M1	1		2	Bush	Bague	Casquillo
13	6190247M1	1		2	Bushing	Bague	Anillo
14	6193446M1	1		2	Seal	Joint	Junta
15	3523057M1	1		2	Bushing	Bague	Anillo
16	3523555M1	1		2	Washer	Rondelle	Arandela
17	6194018M91	1		1	Support Assy	Ensemble de support	Apoyadero, Conj.
18		17	Ref. 17	1	Support	Support	Soporte
19		17	Ref. 17	2	Clamp	Collier de serrage	Argolla de cierre
20	3475335M1	17		4	Bushing	Bague	Anillo
21	3523068M1	17	M14 x 75	4	Screw	Vis	Tornillo
22	3475341M1	1	M15 x 35	2	Pin	Axe	Pasador
23	3475329M1	1	M22	1	Plug	Bouchon	Tapón
24	3523067M1	1	M12 x 33	10	Screw	Vis	Tornillo



820
TX760B

807 808 833 834

16011C02.1

6199042M3

1

Jan-06

Front Axle
Pont Avant
Puente delantero

Housing
Carter
Alojamiento

2 Wheel Steer
2 Roues Directrices
Dirección en 2 ruedas

C-16012-02.1-A

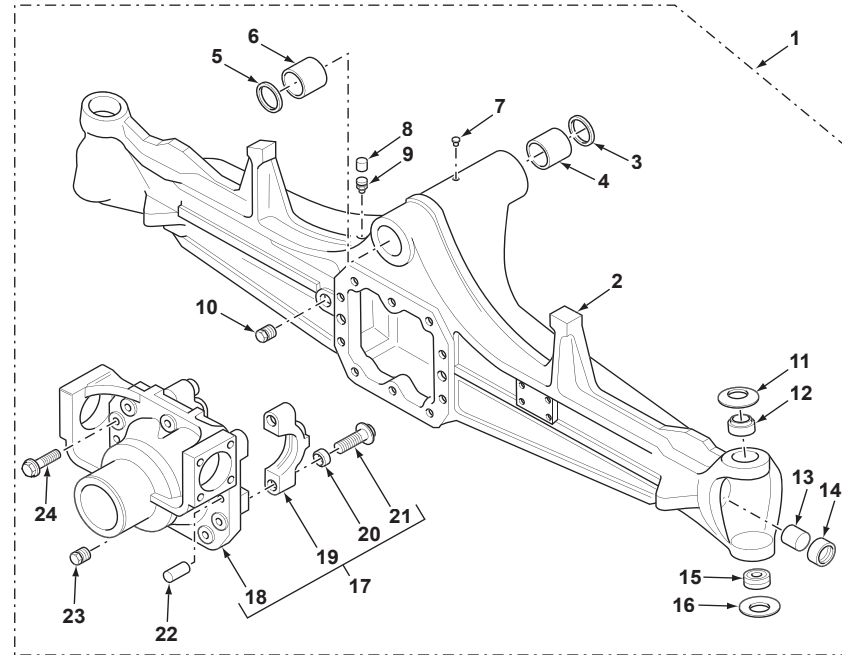

1	6109144M91		Ref: 148093	1	Axle Assy, Front	Montage d'essieu, avant	Puente delantero, Conj.
2	6194031M1	1		1	Housing, Axle	Carter de pont	Cárter de puente
3	6194017M1	1		1	Seal, Oil	Joint à huile	Junta de aceite
4	6194022M1	1		1	Bush	Bague	Casquillo
5	6194017M1	1		1	Seal, Oil	Joint à huile	Junta de aceite
6	6194021M1	1		1	Bush	Bague	Casquillo
7	6193344M1	1		1	Plug	Bouchon	Tapón
8	6194026M1	1		1	Cap	Chapeau	Sombbrero
9	3475328M1	1	M10	1	Breather	Reniflard	Ventilador del cárter
10	3475329M1	1	M22	1	Plug	Bouchon	Tapón
11	3523545M1	1		2	Washer	Rondelle	Arandela
12	6194030M1	1		2	Bush	Bague	Casquillo
13	6190247M1	1		2	Bushing	Bague	Anillo
14	6193446M1	1		2	Seal	Joint	Junta
15	3523057M1	1		2	Bushing	Bague	Anillo
16	3523555M1	1		2	Washer	Rondelle	Arandela
17	6194018M91	1		1	Support Assy	Ensemble de support	Apoyadero, Conj.
18		17	Ref. 17	1	Support	Support	Soporte
19		17	Ref. 17	2	Clamp	Collier de serrage	Argolla de cierre
20	3475335M1	17		4	Bushing	Bague	Anillo
21	3523068M1	17	M14 x 75	4	Screw	Vis	Tornillo
22	3475341M1	1	M15 x 35	2	Pin	Axe	Pasador
23	3475329M1	1	M22	1	Plug	Bouchon	Tapón
24	3523067M1	1	M12 x 33	10	Screw	Vis	Tornillo



820 860 880
TX760B TX860B
TX870B

803 804 813 814 815 816 817 831 832 841 842 843 844 845

16012C02.1

6199042M3

1

Jan-06

Front Axle
Pont Avant
Puente delantero

Housing
Carter
Alojamiento

2 Wheel Steer
2 Roues Directrices
Dirección en 2 ruedas

C-16013-02.1-A

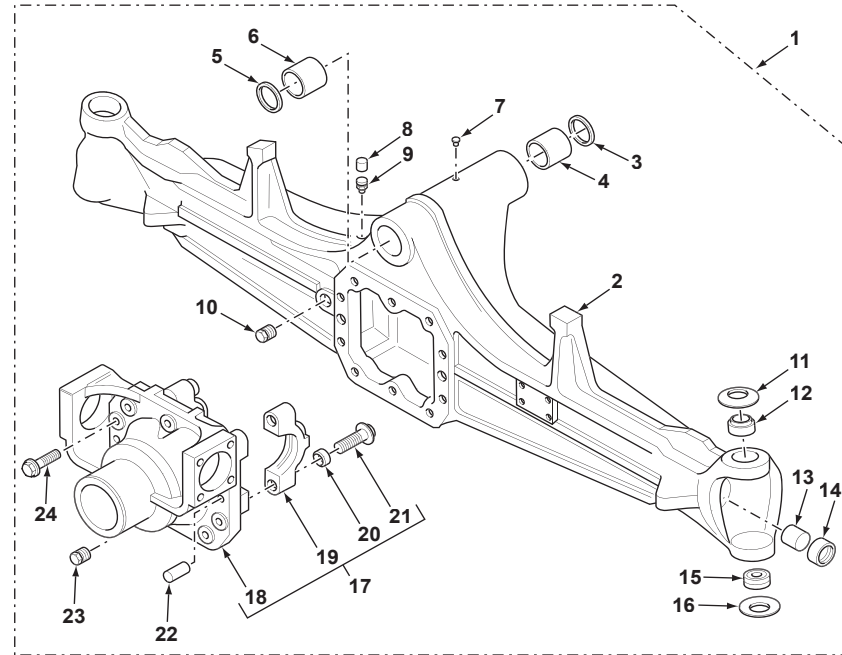

1	6109145M91		Ref: 148648	1	Axle Assy, Front	Montage d'essieu, avant	Puente delantero, Conj.
2	6194031M1	1		1	Housing, Axle	Carter de pont	Cárter de puente
3	6194017M1	1		1	Seal, Oil	Joint à huile	Junta de aceite
4	6194022M1	1		1	Bush	Bague	Casquillo
5	6194017M1	1		1	Seal, Oil	Joint à huile	Junta de aceite
6	6194021M1	1		1	Bush	Bague	Casquillo
7	6193344M1	1		1	Plug	Bouchon	Tapón
8	6194026M1	1		1	Cap	Chapeau	Sombbrero
9	3475328M1	1	M10	1	Breather	Reniflard	Ventilador del cárter
10	3475329M1	1	M22	1	Plug	Bouchon	Tapón
11	3523545M1	1		2	Washer	Rondelle	Arandela
12	6194030M1	1		2	Bush	Bague	Casquillo
13	6190247M1	1		2	Bushing	Bague	Anillo
14	6193446M1	1		2	Seal	Joint	Junta
15	3523057M1	1		2	Bushing	Bague	Anillo
16	3523555M1	1		2	Washer	Rondelle	Arandela
17	6194018M91	1		1	Support Assy	Ensemble de support	Apoyadero, Conj.
18		17	Ref. 17	1	Support	Support	Soporte
19		17	Ref. 17	2	Clamp	Collier de serrage	Argolla de cierre
20	3475335M1	17		4	Bushing	Bague	Anillo
21	3523068M1	17	M14 x 75	4	Screw	Vis	Tornillo
22	3475341M1	1	M15 x 35	2	Pin	Axe	Pasador
23	3475329M1	1	M22	1	Plug	Bouchon	Tapón
24	3523067M1	1	M12 x 33	10	Screw	Vis	Tornillo



860 880
TX860B TX870B

821 822 823 824 825 851 852 853 854 855

16013C02.1

6199042M3

1

Jan-06

Front Axle
Pont Avant
Puente delantero

Housing
Carter
Alojamiento

4 Wheel Steer
4 Roues Directrices
Dirección en las 4 ruedas

C-16014-02.1-A

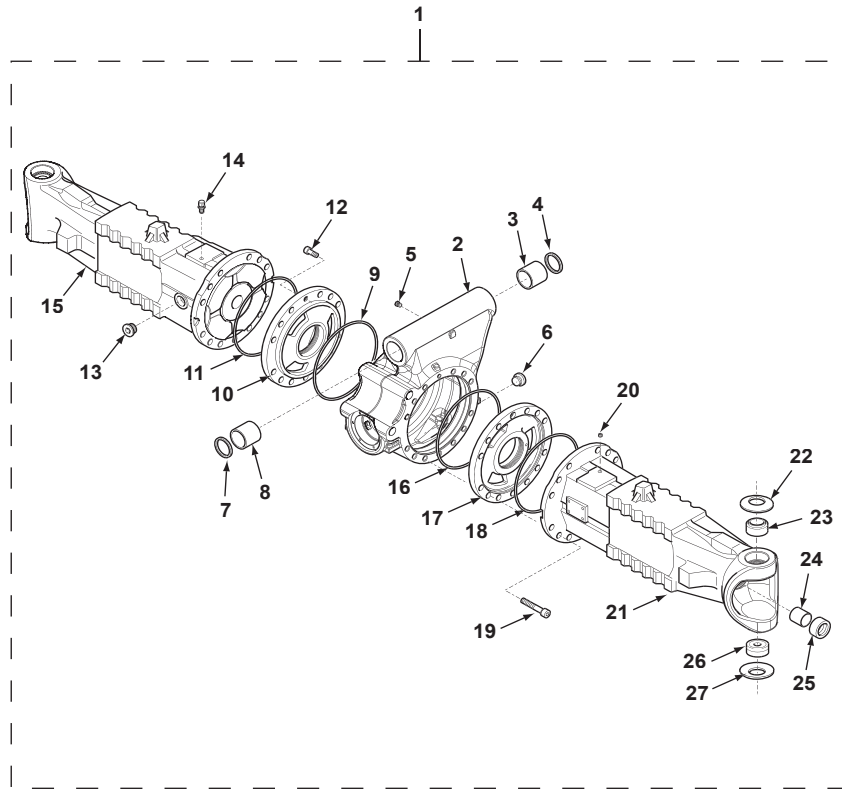

1	6109146M91		Continued Ref: 148930	1	Axle Assy, Front	Montage d'essieu, avant	Puente delantero, Conj.
2	6194258M1	1		1	Housing Assy, Center	Ensemble carter centr	Cárter central, Conj.
3	6194022M1	1		1	Bush	Bague	Casquillo
4	6194017M1	1		1	Seal, Oil	Joint à huile	Junta de aceite
5	6193344M1	1		1	Plug	Bouchon	Tapón
6	3523632M1	1	M30 x 2	1	Plug	Bouchon	Tapón
7	6194017M1	1		1	Seal, Oil	Joint à huile	Junta de aceite
8	6194021M1	1		1	Bush	Bague	Casquillo
9	6193333M1	1		1	O-Ring	Joint torique	Junta de tipo O
10	6194259M1	1		1	Bearing, Support	Palier support	Palier soporte
11	6193333M1	1		1	O-Ring	Joint torique	Junta de tipo O
12	6194260M1	1	M12 x 25	1	Bolt	Boulon	Perno
13	3523632M1	1	M30 x 2	1	Plug	Bouchon	Tapón
14	6193669M1	1	M10	1	Breather	Reniflard	Ventilador del cárter
15	6194262M1	1		1	Housing, Axle	Carter de pont	Cárter de puente
16	6193333M1	1		1	O-Ring	Joint torique	Junta de tipo O
17	6194259M1	1		1	Bearing, Support	Palier support	Palier soporte
18	6193333M1	1		1	O-Ring	Joint torique	Junta de tipo O
19	6194261M1	1	M16 x 65	26	Bolt	Boulon	Perno
20	3523998M1	1	M10 x 1	1	Plug	Bouchon	Tapón
21	6194262M1	1		1	Housing, Axle	Carter de pont	Cárter de puente
22	3523578M1	1		2	Washer	Rondelle	Arandela
23	6194263M1	1		2	Bush	Bague	Casquillo
24	6190247M1	1		2	Bushing	Bague	Anillo
25	6193672M1	1		2	Seal, Ring	Joint, anneau	Junta de anillo
26	3523581M1	1		2	Bushing	Bague	Anillo
27	3523579M1	1		2	Washer	Rondelle	Arandela



970 980
TX970B

921 922 923 931 932

16014C02.1

6199042M3

1

Jan-06

**Front Axle
Pont Avant
Puente delantero**

**Installation
Montage
Instalación**

2 Wheel Drive
2 Roues Motrices
2 ruedas motrices

C-16010-01.1-A

1	6109606M91	Ref: 148394	1	Axle Assy, Front	Montage d'essieu, avant	Puente delantero, Conj.
2	6110099M1		1	Pin	Axe	Pasador
3	1440330X1	M12	1	Nut	Écrou	Tuerca
4	3009518X1	M12 x 110	1	Bolt	Boulon	Perno
5	1441858X1		1	Fitting, Grease	Graisseur	Engrasador
6	3009694X1	M10	1	Nut, Lock	Écrou de blocage	Tuerca de retención
7	3521240M1		1	Fitting	Raccord	Racor
8	6110196M91		1	Hose Assy	Ensemble de flexible	Flexible, Conj.
9	358760X91		1	Elbow, 90°	Coude à 90°	Codo, 90°
10		9	1	Elbow	Coude	Codo
11	831495m1	9	1	O-Ring	Joint torique	Junta de tipo O
12	6110204M1		16	Stud	Goujon	Espárrago

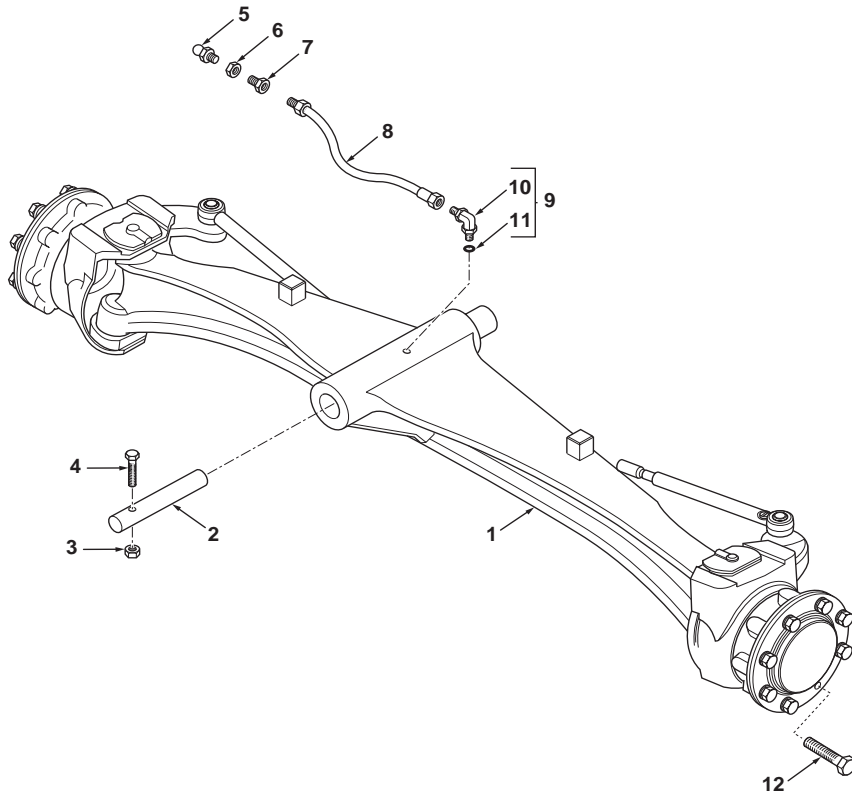

820
TX760B TX860B

801 802 805 806 809 810

16010C01.1

6199042M3

1

Jan-06

Front Axle
Pont Avant
Puente delantero

Installation
Montage
Instalación

2 Wheel Steer
 2 Roues Directrices
 Dirección en 2 ruedas

C-16011-01.1-B

1	6109000M91	Ref: 148092	1	Axle Assy, Front	Montage d'essieu, avant	Puente delantero, Conj.
2	6110099M1		1	Pin	Axe	Pasador
3	1440330X1	M12	1	Nut	Écrou	Tuerca
4	3009518X1	M12 x 110	1	Bolt	Boulon	Perno
5	1441858X1		1	Fitting, Grease	Graisneur	Engrasador
6	3009694X1	M10	1	Nut, Lock	Écrou de blocage	Tuerca de retención
7	3521240M1		1	Fitting	Raccord	Racor
8	6110196M91		1	Hose Assy	Ensemble de flexible	Flexible, Conj.
9	358760X91		1	Elbow, 90°	Coude à 90°	Codo, 90°
10		9	1	Elbow	Coude	Codo
11	831495M1	9	1	O-Ring	Joint torique	Junta de tipo O
12	6102490M1		1	Relay	Relais	Relé

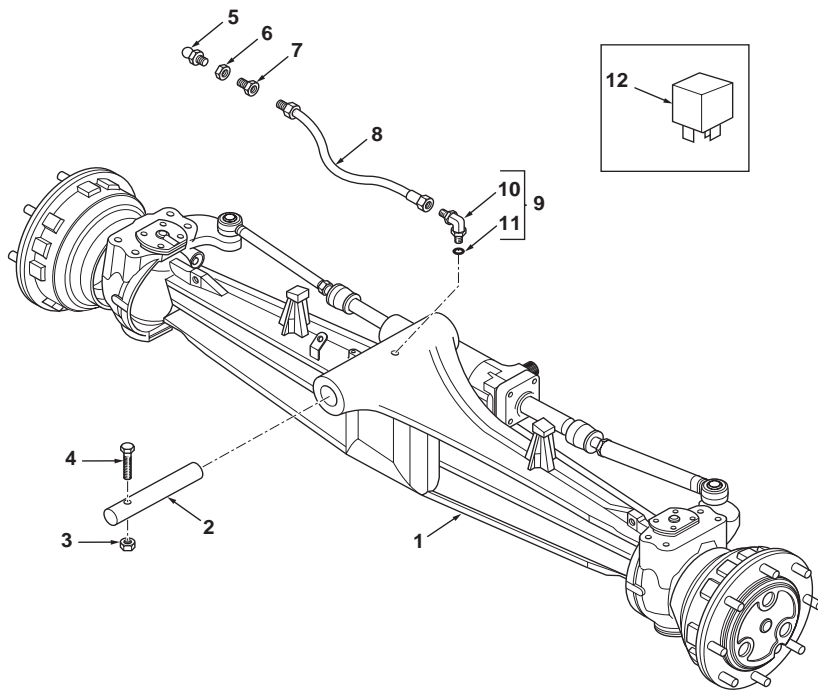

820
 TX760B

807 808 833 834

16011C01.1

6199042M3

1

Jan-06

Front Axle
Pont Avant
Puente delantero

Installation
Montage
Instalación

2 Wheel Steer
 2 Roues Directrices
 Dirección en 2 ruedas

C-16012-01.1-B

1	6109144M91	Ref: 148093	1	Axle Assy, Front	Montage d'essieu, avant	Puente delantero, Conj.
2	6110099M1		1	Pin	Axe	Pasador
3	1440330X1	M12	1	Nut	Écrou	Tuerca
4	3009518X1	M12 x 110	1	Bolt	Boulon	Perno
5	1441858X1		1	Fitting, Grease	Graisneur	Engrasador
6	3009694X1	M10	1	Nut, Lock	Écrou de blocage	Tuerca de retención
7	3521240M1		1	Fitting	Raccord	Racor
8	6110197M91		1	Hose Assy	Ensemble de flexible	Flexible, Conj.
9	358760X91		1	Elbow, 90°	Coude à 90°	Codo, 90°
10		9	1	Elbow	Coude	Codo
11	831495M1	9	1	O-Ring	Joint torique	Junta de tipo O
12	6102490M1		1	Relay	Relais	Relé

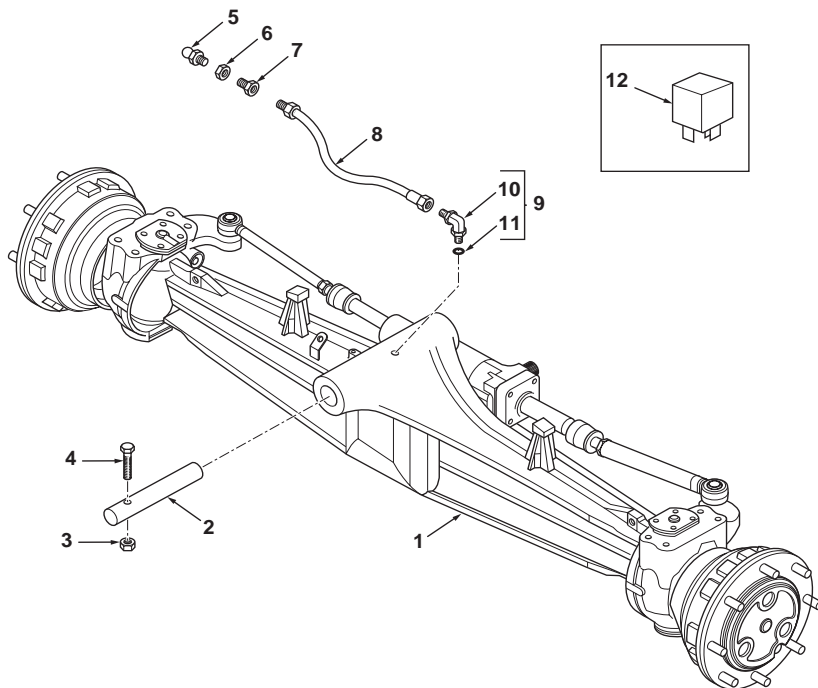

820 860 880
 TX760B TX860B
 TX870B

803 804 813 814 815 816 817 831 832 841 842 843 844 845

16012C01.1

6199042M3

1

Jan-06

Front Axle
Pont Avant
Puente delantero

Installation
Montage
Instalación

2 Wheel Steer
 2 Roues Directrices
 Dirección en 2 ruedas

C-16013-01.1-B

1	6109145M91	Ref: 148648	1	Axle Assy, Front	Montage d'essieu, avant	Puente delantero, Conj.
2	6110099M1		1	Pin	Axe	Pasador
3	1440330X1	M12	1	Nut	Écrou	Tuerca
4	3009518X1	M12 x 110	1	Bolt	Boulon	Perno
5	1441858X1		1	Fitting, Grease	Graisneur	Engrasador
6	3009694X1	M10	1	Nut, Lock	Écrou de blocage	Tuerca de retención
7	3521240M1		1	Fitting	Raccord	Racor
8	6110197M91		1	Hose Assy	Ensemble de flexible	Flexible, Conj.
9	358760X91		1	Elbow, 90°	Coude à 90°	Codo, 90°
10		9	1	Elbow	Coude	Codo
11	831495M1	9	1	O-Ring	Joint torique	Junta de tipo O
12	6102490M1		1	Relay	Relais	Relé

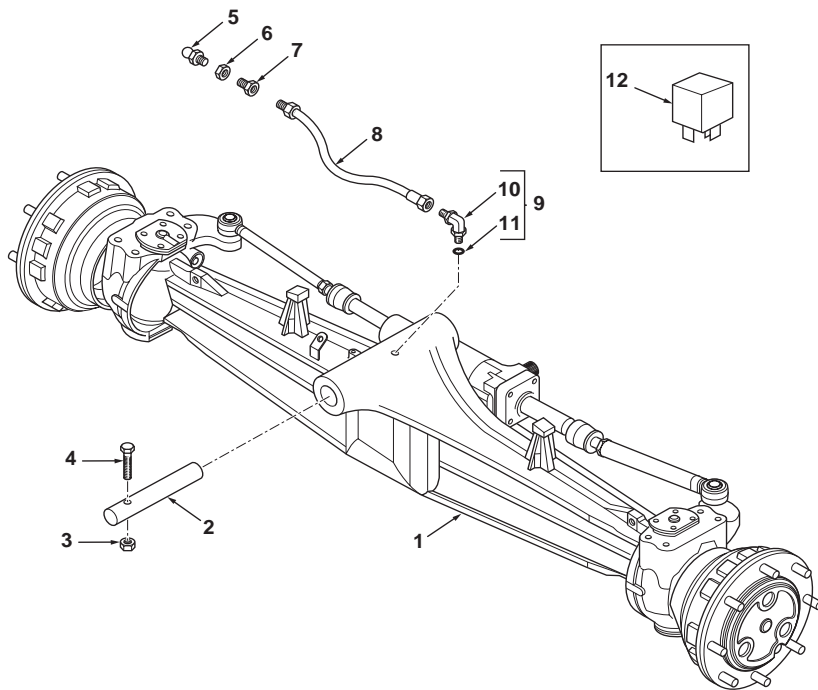

860 880
 TX860B TX870B

821 822 823 824 825 851 852 853 854 855

16013C01.1

6199042M3

1

Jan-06

**Front Axle
Pont Avant
Puente delantero**

**Installation
Montage
Instalación**

4 Wheel Steer
4 Roues Directrices
Dirección en las 4 ruedas

C-16014-01.1-B

1	6109146M91	Ref: 148930	1	Axle Assy, Front	Montage d'essieu, avant	Puente delantero, Conj.
2	6110100M1		1	Pin	Axe	Pasador
3	1440330X1	M12	1	Nut	Écrou	Tuerca
4	3009518X1	M12 x 110	1	Bolt	Boulon	Perno
5	1441858X1		1	Fitting, Grease	Graisseur	Engrasador
6	3009694X1	M10	1	Nut, Lock	Écrou de blocage	Tuerca de retención
7	3521240M1		1	Fitting	Raccord	Racor
8	6110198M91		1	Hose Assy	Ensemble de flexible	Flexible, Conj.
9	358760X91		1	Elbow, 90°	Coude à 90°	Codo, 90°
10		9	1	Elbow	Coude	Codo
11	831495M1	9	1	O-Ring	Joint torique	Junta de tipo O
12	6106829M91		20	Nut	Écrou	Tuerca
13	6102490M1		1	Relay	Relais	Relé

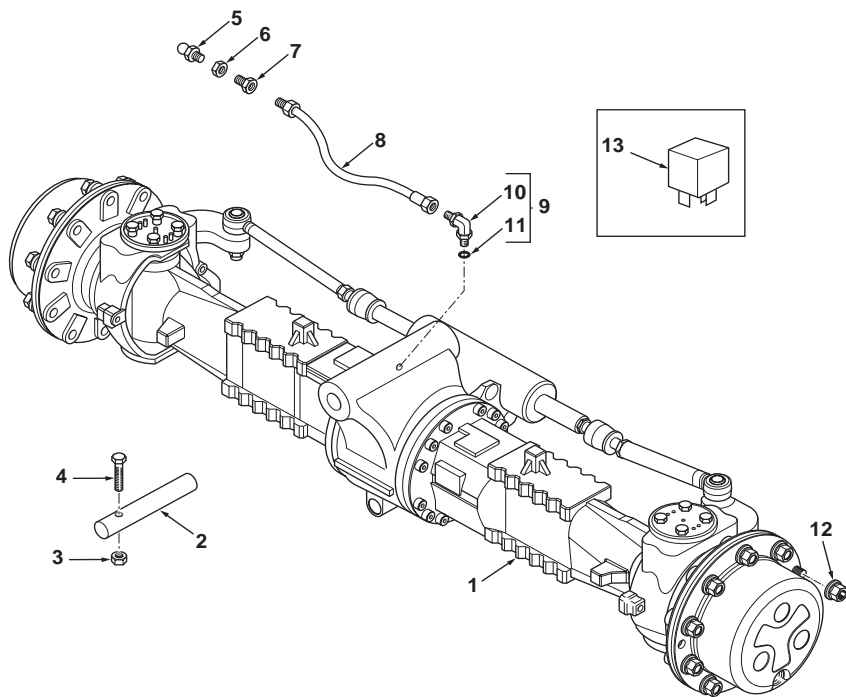

970 980
TX970B

921 922 923 931 932

16014C01.1

6199042M3

1

Jan-06

Front Axle
Pont Avant
Puede delantero

Installation
Montage
Instalación

2 Wheel Steer
2 Roues Directrices
Dirección en 2 ruedas

Not Illustrated

Non Illustrée

Nicht Abgebildet

Non Illustrato

No Ilustrado

1	6110552M91			1	Axle Assy, Front	Montage d'essieu, avant	Puede delantero, Conj.
2	6110099M1			1	Pin	Axe	Pasador
3	1440330X1	M12		1	Nut	Écrou	Tuerca
4	3009518X1	M12 x 110		1	Bolt	Boulon	Perno
5	1441858X1			1	Fitting, Grease	Graisseur	Engrasador
6	3009694X1	M10		1	Nut, Lock	Écrou de blocage	Tuerca de retención
7	3521240M1			1	Fitting	Raccord	Racor
8	6110196M91			1	Hose Assy	Ensemble de flexible	Flexible, Conj.
9	358760X91		 Ref. 9	1	Elbow, 90°	Coude à 90°	Codo, 90°
10		9		1	Elbow	Coude	Codo
11	831495M1	9		1	O-Ring	Joint torique	Junta de tipo O
12	6102490M1			1	Relay	Relais	Relé



820
TX760B

807 808

Front Axle
Pont Avant
Puente delantero

Installation
Montage
Instalación

2 Wheel Steer
 2 Roues Directrices
 Dirección en 2 ruedas

C-16015-02.1-C

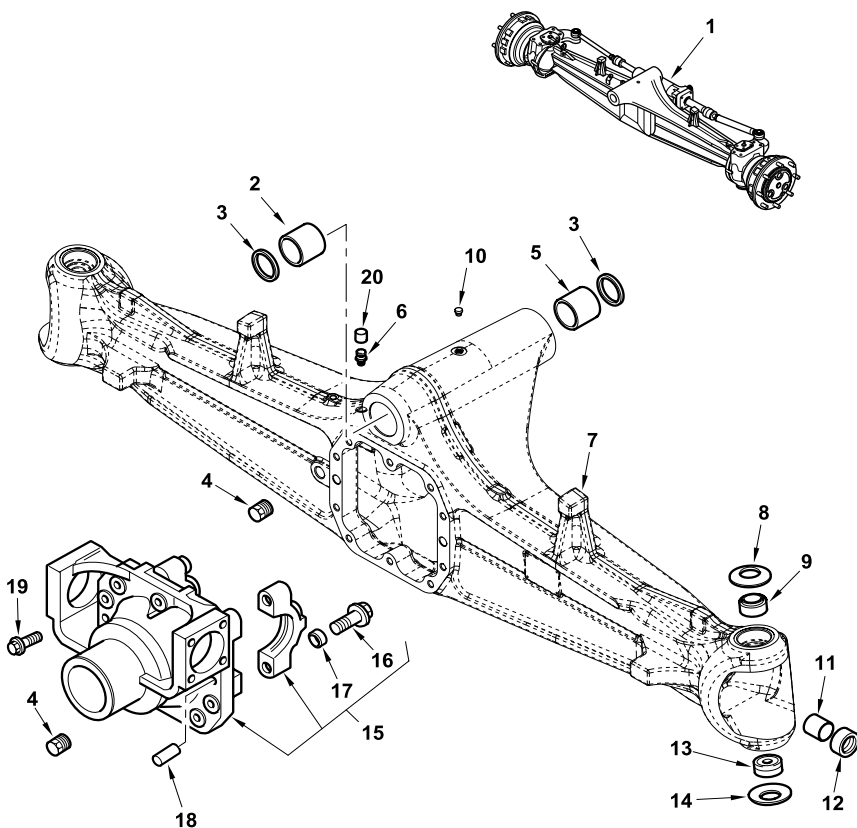

1	6110552M91			1	Axle Assy, Front	Montage d'essieu, avant	Puente delantero, Conj.
2	6194021M1			1	Bush	Bague	Casquillo
3	6194017M1			2	Seal, Oil	Joint à huile	Junta de aceite
4	3475329M1	M22		2	Plug	Bouchon	Tapón
5	6194022M1			1	Bush	Bague	Casquillo
6	3475328M1	M10		1	Breather	Reniflard	Ventilador del cárter
7	6194031M1			1	Housing, Axle	Carter de pont	Cárter de puente
8	3523545M1			2	Washer	Rondelle	Arandela
9	6194030M1			2	Bush	Bague	Casquillo
10	6193344M1			1	Plug	Bouchon	Tapón
11	6190247M1			2	Bushing	Bague	Anillo
12	6193446M1			2	Seal	Joint	Junta
13	3523057M1			2	Bushing	Bague	Anillo
14	3523555M1			2	Washer	Rondelle	Arandela
15	6194018M91			1	Support Assy	Ensemble de support	Apyadero, Conj.
16	3523068M1	15	M14 x 75	4	Screw	Vis	Tornillo
17	3475335M1	15		4	Bushing	Bague	Anillo
18	3475341M1		M15 x 35	2	Pin	Axe	Pasador
19	3523067M1		M12 x 33	10	Screw	Vis	Tornillo
20	6194026M1			1	Cap	Chapeau	Sombbrero



820
TX760B

807 808

16015C02.1

6199042M3

1

Jan-06

**Front Axle
Pont Avant
Puente delantero**

**Installation
Montage
Instalación**

2 Wheel Steer
2 Roues Directrices
Dirección en 2 ruedas

C-16015-03.1-C

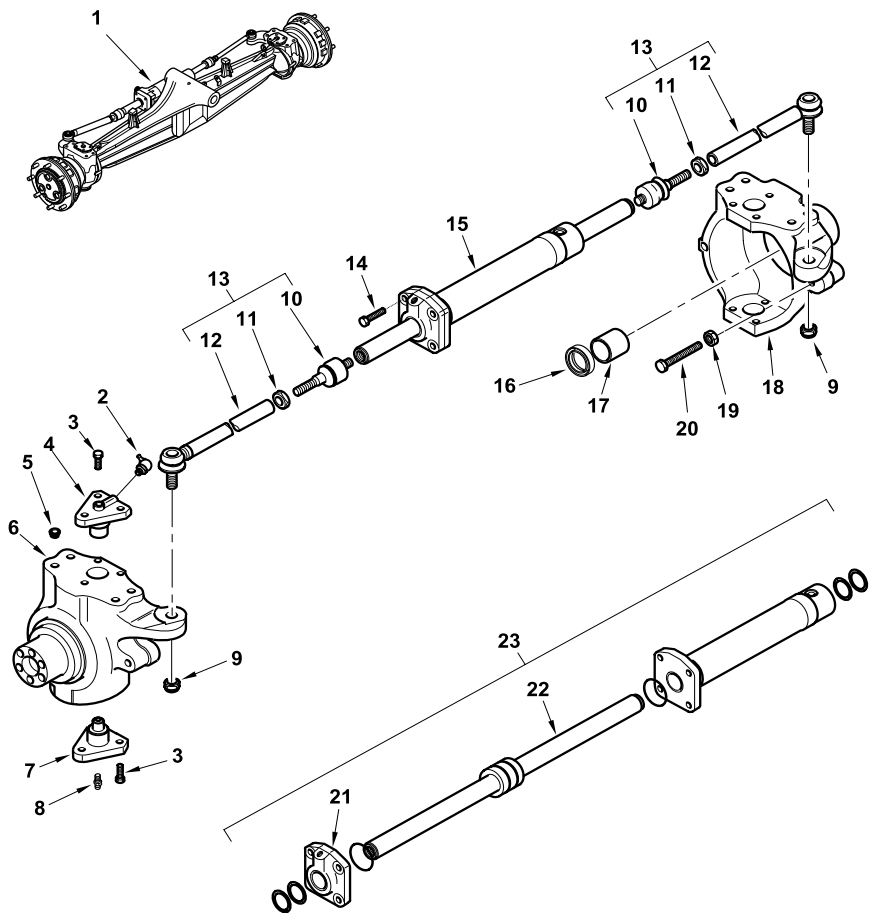

1	6110552M91		1	Axle Assy, Front	Montage d'essieu, avant	Puente delantero, Conj.
2	6193432M1		2	Fitting, Grease	Graisseur	Engrasador
3	3523548M1	M14 x 35	12	Screw	Vis	Tornillo
4	6190565M1		2	Pin	Axe	Pasador
5	6194007M1		8	Plug	Bouchon	Tapón
6	6194029M1		1	Housing, Swivel	Carter, pivot	Cárter, junta giratoria
7	6190566M1		2	Pin	Axe	Pasador
8	6190567M1		2	Fitting, Grease	Graisseur	Engrasador
9	6190221M1	M20	2	Nut	Écrou	Tuerca
10	6194012M1	13	2	Ball Joint	Rotule	Rotula
11	6193677M1	13 M24	2	Nut	Écrou	Tuerca
12	6194011M91	13	2	Tie Rod Assy	Barre direction, mont.	Barra dirección, Conj.
13	6194019M91		2	Arm Assy	Ensemble de bras	Brazo, Conj.
14	6194024M1	M12 x 45	4	Bolt	Boulon	Perno
15	6194023M91		1	Cylinder, Steering	Vérin de direction	Gato de dirección
16	6193433M1		2	Seal, Oil	Joint à huile	Junta de aceite
17	3475535M1		2	Bushing	Bague	Anillo
18	6194028M1		1	Housing, Swivel	Carter, pivot	Cárter, junta giratoria
19	6194272M1	M16	2	Nut	Écrou	Tuerca
20	6194020M1	M16 x 100	2	Bolt	Boulon	Perno
21	6194014M1	23	1	Head, Cylinder	Culasse	Culata
22	6194013M1	23	1	Rod	Tringle	Vástago
23	6194015M91		1	Kit, Seal	Pochette de joints	Juego de juntas



820
TX760B

807 808

16015C03.1

6199042M3

1

Jan-06

Front Axle
Pont Avant
Puente delantero

Installation
Montage
Instalación

2 Wheel Steer
 2 Roues Directrices
 Dirección en 2 ruedas

C-16015-04.1-C

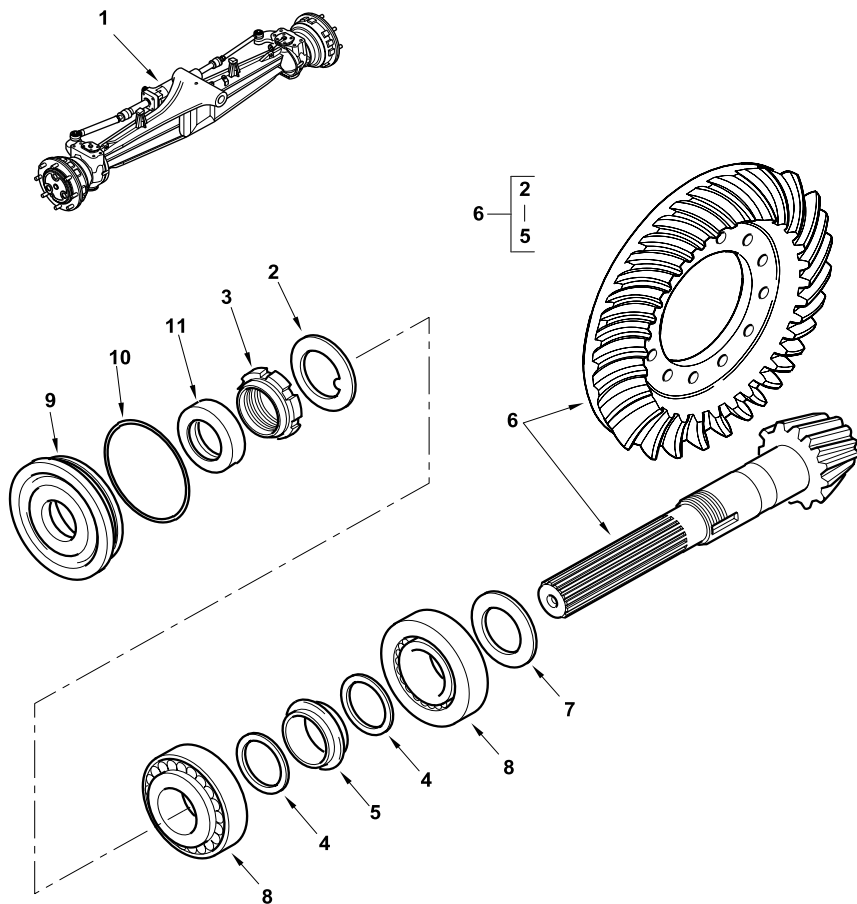

1	6110552M91			1	Axle Assy, Front	Montage d'essieu, avant	Puente delantero, Conj.
2	3475569M1	6		1	Washer, Lock	Rondelle de blocage	Arandela de freno
3	3475570M1	6	M40	1	Nut	Écrou	Tuerca
4	3523082M1	6		2	Washer	Rondelle	Arandela
5	3523083M1	6		1	Spacer	Entretoise	Traviesa
6	6194506M91			1	Relief Valve Kit	Kit Soupape de sûreté	Kit de válvula de alivio
7	6190197M1	2,5 mm		1	Shim	Cale	Calce
7	6190198M1	2,6 mm		1	Shim	Cale	Calce
7	6190199M1	2,7 mm		1	Shim	Cale	Calce
7	6190200M1	2,8 mm		1	Shim	Cale	Calce
7	6190201M1	2,9 mm		1	Shim	Cale	Calce
7	6190202M1	3,0 mm		1	Shim	Cale	Calce
7	6190203M1	3,1 mm		1	Shim	Cale	Calce
7	6190204M1	3,2 mm		1	Shim	Cale	Calce
7	6190205M1	3,3 mm		1	Shim	Cale	Calce
7	6190206M1	3,4 mm		1	Shim	Cale	Calce
8	3475567M1			2	Bearing, Ball	Roulement à billes	Cojinete de bolas
9	6194025M1			1	Cover	Cache	Tapa
10	6194006M1			1	O-Ring	Joint torique	Junta de tipo O
11	6193433M1			1	Seal, Oil	Joint à huile	Junta de aceite



820
TX760B

807 808

16015C04.1

6199042M3

1

Jan-06

**Front Axle
Pont Avant
Puente delantero**

**Installation
Montage
Instalación**

2 Wheel Steer
2 Roues Directrices
Dirección en 2 ruedas

C-16015-05.1-C

1	6110552M91			1	Axle Assy, Front	Montage d'essieu, avant	Puente delantero, Conj.
2	6190225M91			1	Kit, Differential	Jeu, différentiel	Juego, Diferencial
3	3475579M1	2		2	Washer, Thrust	Rondelle de butée	Arandela de tope
4	3523085M1	2		1	Shaft	Arbre	Árbol
5	3523088M1	2		1	Pin, Dowel	Goupille position.	Peón
6	3523583M1		M6 x 10	2	Screw	Vis	Tornillo
7	3475583M1			2	Plate	Plaque	Placa
8	3475584M1			2	Nut	Écrou	Tuerca
9	3475585M1			2	Bearing, Roller	Rouleau de roulement	Cojinete, Rodillos
10	3475581M1	2		2	Washer, Thrust	Rondelle de butée	Arandela de tope
11	6194507M91			1	Housing, Differential	Logement, Différentiel	Cárter, diferencial
12	3523086M1		M10 x 75	12	Screw	Vis	Tornillo

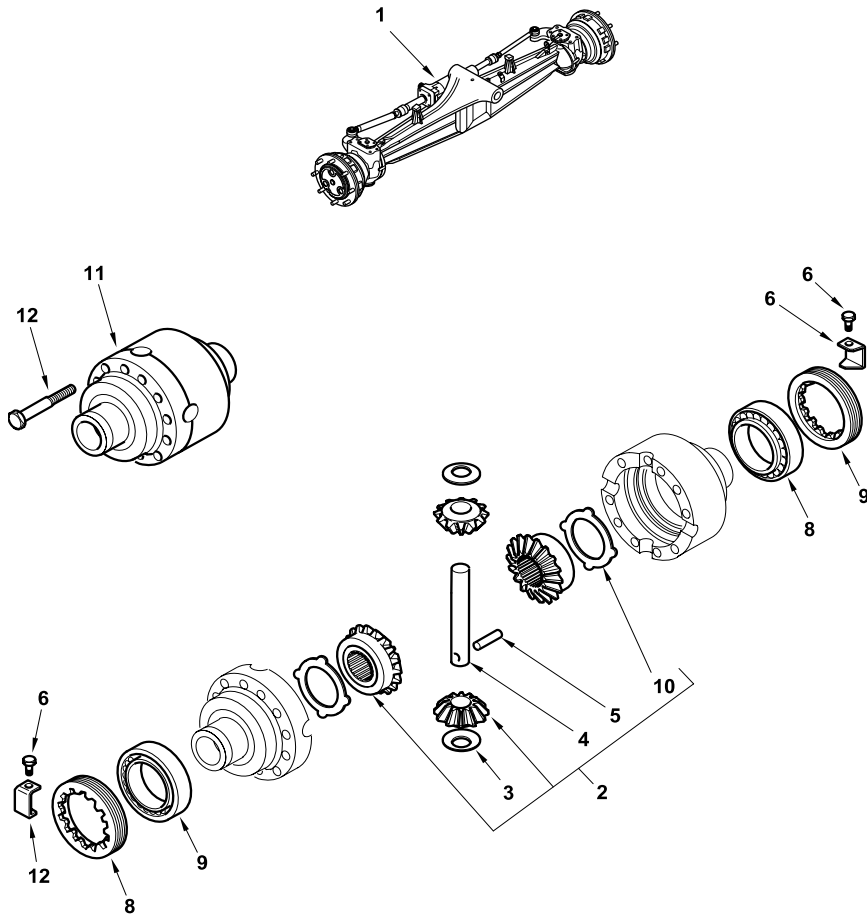

820
TX760B

807 808

16015C05.1

6199042M3

1

Jan-06

Front Axle
Pont Avant
Puente delantero

Installation
Montage
Instalación

2 Wheel Steer
2 Roues Directrices
Dirección en 2 ruedas

C-16015-06.1-C

1	6110552M91			1	Axle Assy, Front	Montage d'essieu, avant	Puente delantero, Conj.
2	6194032M91			2	Shaft, Axle	Arbre de pont	Árbol de puente
3	6194008M1	2		2	Shaft	Arbre	Árbol
4	6194009M1	2		2	Clevis	Chape	Brida
5	3476313M1	6		16	Ring, Snap	Anneau d'arrêt	Anillo de resorte
6	6194010M91	2		4	Spider Assy	Ensemble croisillon	Cruceta, Conj.
7	3476312M1	2		2	Shaft	Arbre	Árbol
8	3523329M1			2	Spacer	Entretoise	Travesa

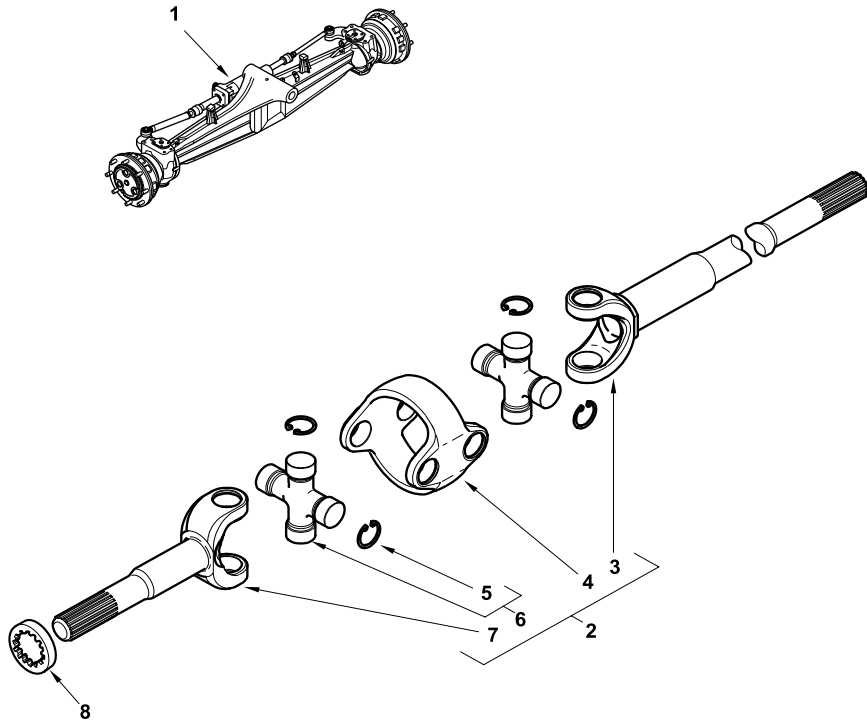

820
TX760B

807 808

16015C06.1

6199042M3

1

Jan-06

**Front Axle
Pont Avant
Puente delantero**

**Installation
Montage
Instalación**

2 Wheel Steer
2 Roues Directrices
Dirección en 2 ruedas

C-16015-07.1-C

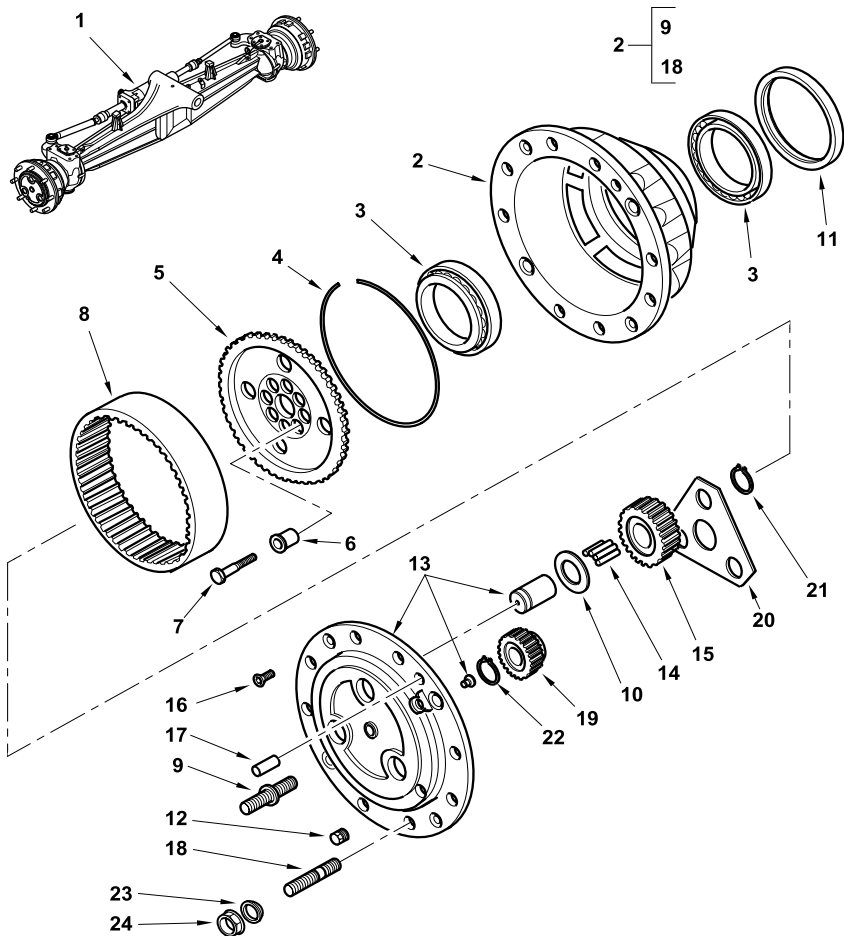

1	6110552M91		1	Axle Assy, Front	Montage d'essieu, avant	Puente delantero, Conj.
2	6193331M91		2	Kit, Wheel Hub	Jeu, moyeu de roue	Juego, Cubo de rueda
3	3475599M1		4	Bearing, Ball	Roulement à billes	Cojinete de bolas
4	3523070M1		2	Ring	Anneau	Aro
5	6193434M1		2	Carrier	Support	Portador
6	3523272M1	dia 20	16	Bushing	Bague	Anillo
7	3475604M1	M14 x 65	16	Screw	Vis	Tornillo
8	3523072M1		2	Ring, Gear	Couronne dentée	Corona dentada
9	3475613M1	2	12	Stud	Goujon	Espárrago
10	3475625M1		6	Washer	Rondelle	Arandela
11	6193704M1		2	Seal, Ring	Joint, anneau	Junta de anillo
12	3475329M1	M22	2	Plug	Bouchon	Tapón
13	3523905M91		2	Carrier, Pinion	Porte-satellites	Portasatélites
14	3523075M1		18	Needle	Aiguille	Aguja
15	3523074M1		6	Gear, Planetary	Planétaire	Piñón planetario
16	3475622M1	M12 x 30	4	Screw	Vis	Tornillo
17	3475618M1		4	Pin	Axe	Pasador
18	3475614M1	2	4	Stud	Goujon	Espárrago
19	3475594M1		2	Gear	Pignon	Piñón
20	3523073M1		2	Bearing, Support	Palier support	Palier soporte
21	3523098M1		6	Ring, Snap	Anneau d'arrêt	Anillo de resorte
22	3475595M1		2	Ring, Snap	Anneau d'arrêt	Anillo de resorte
23	3475615M1		16	Washer	Rondelle	Arandela
24	3475616M1		16	Nut	Écrou	Tuerca



820
TX760B

807 808

16015C07.1

6199042M3

1

Jan-06

**Front Axle
Pont Avant
Puente delantero**

**Installation
Montage
Instalación**

2 Wheel Steer
2 Roues Directrices
Dirección en 2 ruedas

C-16016-01.1-B

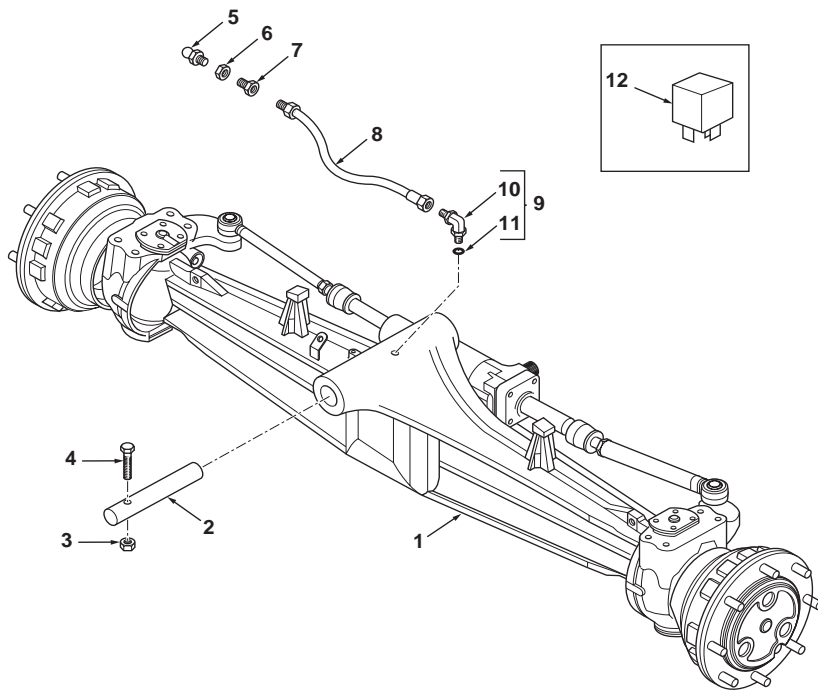

1	6110551M91	(A)	1	Axle Assy, Front	Montage d'essieu, avant	Puente delantero, Conj.
2	6110099M1		1	Pin	Axe	Pasador
3	1440330X1	M12	1	Nut	Écrou	Tuerca
4	3009518X1	M12 x 110	1	Bolt	Boulon	Perno
5	1441858X1		1	Fitting, Grease	Graisneur	Engrasador
6	3009694X1	M10	1	Nut, Lock	Écrou de blocage	Tuerca de retención
7	3521240M1		1	Fitting	Raccord	Racor
8	6110197M91		1	Hose Assy	Ensemble de flexible	Flexible, Conj.
9	358760X91		1	Elbow, 90°	Coude à 90°	Codo, 90°
10		9	1	Elbow	Coude	Codo
11	831495M1	9	1	O-Ring	Joint torique	Junta de tipo O
12	6102490M1		1	Relay	Relais	Relé

A Details to be advised
Détails à demander
Detalles que deben ser notificados



820 860 880
TX760B TX860B
TX870B

803 804 813 814 815 816 817 841 842 843 844 845

16016C01.1

6199042M3

1

Jan-06

**Front Axle
Pont Avant
Puente delantero**

**Installation
Montage
Instalación**

2 Wheel Steer
2 Roues Directrices
Dirección en 2 ruedas

C-16016-02.1-C

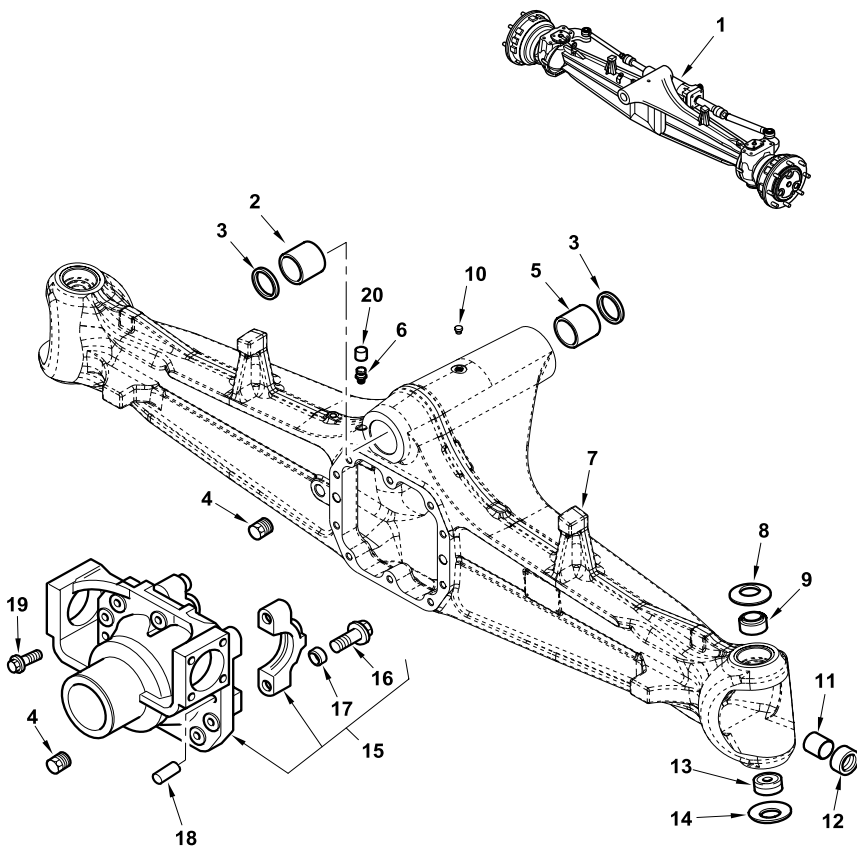

1	6110552M91			1	Axle Assy, Front	Montage d'essieu, avant	Puente delantero, Conj.
2	6194021M1			1	Bush	Bague	Casquillo
3	6194017M1			2	Seal, Oil	Joint à huile	Junta de aceite
4	3475329M1	M22		2	Plug	Bouchon	Tapón
5	6194022M1			1	Bush	Bague	Casquillo
6	3475328M1	M10		1	Breather	Reniflard	Ventilador del cárter
7	6194031M1			1	Housing, Axle	Carter de pont	Cárter de puente
8	3523545M1			2	Washer	Rondelle	Arandela
9	6194030M1			2	Bush	Bague	Casquillo
10	6193344M1			1	Plug	Bouchon	Tapón
11	6190247M1			2	Bushing	Bague	Anillo
12	6193446M1			2	Seal	Joint	Junta
13	3523057M1			2	Bushing	Bague	Anillo
14	3523555M1			2	Washer	Rondelle	Arandela
15	6194018M91			1	Support Assy	Ensemble de support	Apyadero, Conj.
16	3523068M1	15	M14 x 75	4	Screw	Vis	Tornillo
17	3475335M1	15		4	Bushing	Bague	Anillo
18	3475341M1		M15 x 35	2	Pin	Axe	Pasador
19	3523067M1		M12 x 33	10	Screw	Vis	Tornillo
20	6194026M1			1	Cap	Chapeau	Sombbrero



820 860 880
TX760B TX860B
TX870B

803 804 813 814 815 816 817 841 842 843 844 845

16016C02.1

6199042M3

1

Jan-06

Front Axle
Pont Avant
Puente delantero

Installation
Montage
Instalación

2 Wheel Steer
 2 Roues Directrices
 Dirección en 2 ruedas

C-16016-03.1-C

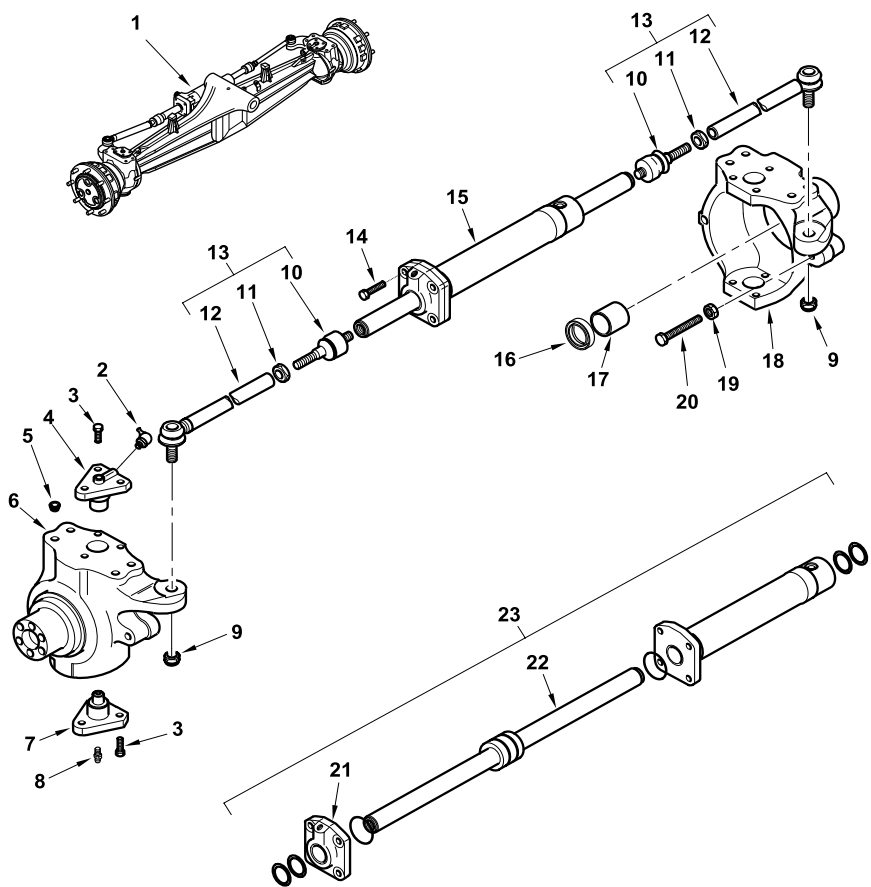

1	6110552M91		1	Axle Assy, Front	Montage d'essieu, avant	Puente delantero, Conj.
2	6193432M1		2	Fitting, Grease	Graisseur	Engrasador
3	3523548M1	M14 x 35	12	Screw	Vis	Tornillo
4	6190565M1		2	Pin	Axe	Pasador
5	6194007M1		8	Plug	Bouchon	Tapón
6	6194029M1		1	Housing, Swivel	Carter, pivot	Cárter, junta giratoria
7	6190566M1		2	Pin	Axe	Pasador
8	6190567M1		2	Fitting, Grease	Graisseur	Engrasador
9	6190221M1	M20	2	Nut	Écrou	Tuerca
10	6194012M1	13	2	Ball Joint	Rotule	Rotula
11	6193677M1	13 M24	2	Nut	Écrou	Tuerca
12	6194011M91	13	2	Tie Rod Assy	Barre direction, mont.	Barra dirección, Conj.
13	6194019M91		2	Arm Assy	Ensemble de bras	Brazo, Conj.
14	6194024M1	M12 x 45	4	Bolt	Boulon	Perno
15	6194023M91		1	Cylinder, Steering	Vérin de direction	Gato de dirección
16	6193433M1		2	Seal, Oil	Joint à huile	Junta de aceite
17	3475535M1		2	Bushing	Bague	Anillo
18	6194028M1		1	Housing, Swivel	Carter, pivot	Cárter, junta giratoria
19	6194272M1	M16	2	Nut	Écrou	Tuerca
20	6194020M1	M16 x 100	2	Bolt	Boulon	Perno
21	6194014M1	23	1	Head, Cylinder	Culasse	Culata
22	6194013M1	23	1	Rod	Tringle	Vástago
23	6194015M91		1	Kit, Seal	Pochette de joints	Juego de juntas



820 860 880
 TX760B TX860B
 TX870B

803 804 813 814 815 816 817 841 842 843 844 845

16016C03.1

6199042M3

1

Jan-06

Front Axle
Pont Avant
Puente delantero

Installation
Montage
Instalación

2 Wheel Steer
 2 Roues Directrices
 Dirección en 2 ruedas

C-16016-04.1-C

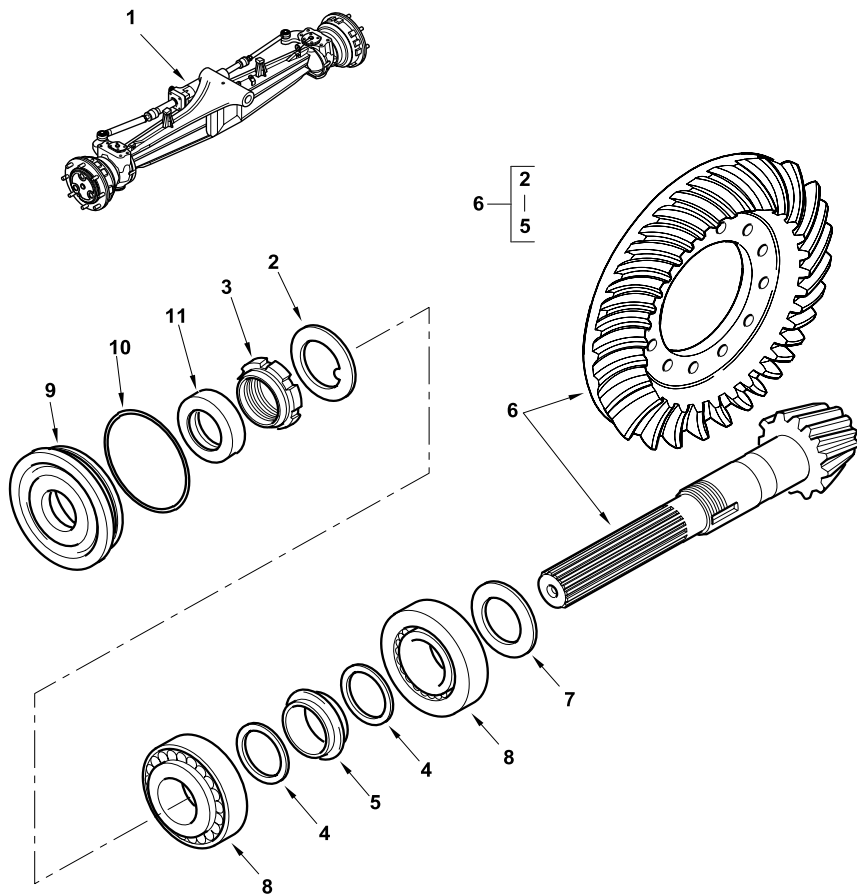

1	6110552M91			1	Axle Assy, Front	Montage d'essieu, avant	Puente delantero, Conj.
2	3475569M1	6		1	Washer, Lock	Rondelle de blocage	Arandela de freno
3	3475570M1	6	M40	1	Nut	Écrou	Tuerca
4	3523082M1	6		2	Washer	Rondelle	Arandela
5	3523083M1	6		1	Spacer	Entretoise	Traviesa
6	6194508M91		12/33	1	Bevel gear/Pinion set	Jeu Engrenage conique/ Pignon	Engranaje cónico/piñón
7	6190197M1	2,5 mm		1	Shim	Cale	Calce
7	6190198M1	2,6 mm		1	Shim	Cale	Calce
7	6190199M1	2,7 mm		1	Shim	Cale	Calce
7	6190200M1	2,8 mm		1	Shim	Cale	Calce
7	6190201M1	2,9 mm		1	Shim	Cale	Calce
7	6190202M1	3,0 mm		1	Shim	Cale	Calce
7	6190203M1	3,1 mm		1	Shim	Cale	Calce
7	6190204M1	3,2 mm		1	Shim	Cale	Calce
7	6190205M1	3,3 mm		1	Shim	Cale	Calce
7	6190206M1	3,4 mm		1	Shim	Cale	Calce
8	3475567M1			2	Bearing, Ball	Roulement à billes	Cojinete de bolas
9	6194025M1			1	Cover	Cache	Tapa
10	6194006M1			1	O-Ring	Joint torique	Junta de tipo O
11	6193433M1			1	Seal, Oil	Joint à huile	Junta de aceite



820 860 880
 TX760B TX860B
 TX870B

803 804 813 814 815 816 817 841 842 843 844 845

16016C04.1

6199042M3

1

Jan-06

Front Axle
Pont Avant
Puente delantero

Installation
Montage
Instalación

2 Wheel Steer
 2 Roues Directrices
 Dirección en 2 ruedas

C-16016-05.1-C

1	6110552M91			1	Axle Assy, Front	Montage d'essieu, avant	Puente delantero, Conj.
2	6190225M91			1	Kit, Differential	Jeu, différentiel	Juego, Diferencial
3	3475579M1	2		2	Washer, Thrust	Rondelle de butée	Arandela de tope
4	3523085M1	2		1	Shaft	Arbre	Árbol
5	3523088M1	2		1	Pin, Dowel	Goupille position.	Peón
6	3523583M1		M6 x 10	2	Screw	Vis	Tornillo
7	3475583M1			2	Plate	Plaque	Placa
8	3475584M1			2	Nut	Écrou	Tuerca
9	3475585M1			2	Bearing, Roller	Rouleau de roulement	Cojinete, Rodillos
10	3475581M1	2		2	Washer, Thrust	Rondelle de butée	Arandela de tope
11	6194507M91			1	Housing, Differential	Logement, Différentiel	Cárter, diferencial
12	3523086M1		M10 x 75	12	Screw	Vis	Tornillo

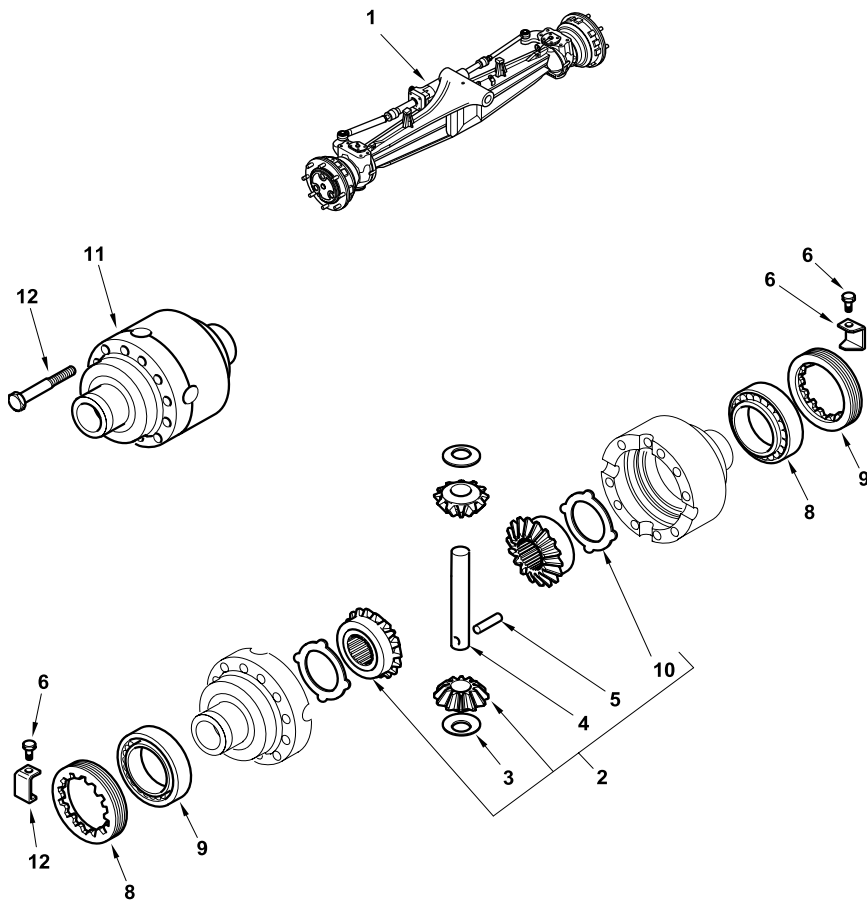

820 860 880
 TX760B TX860B
 TX870B

803 804 813 814 815 816 817 841 842 843 844 845

16016C05.1

6199042M3

1

Jan-06

Front Axle
Pont Avant
Puente delantero

Installation
Montage
Instalación

2 Wheel Steer
2 Roues Directrices
Dirección en 2 ruedas

C-16016-06.1-C

1	6110552M91			1	Axle Assy, Front	Montage d'essieu, avant	Puente delantero, Conj.
2	6194032M91			2	Shaft, Axle	Arbre de pont	Árbol de puente
3	6194008M1	2		2	Shaft	Arbre	Árbol
4	6194009M1	2		2	Clevis	Chape	Brida
5	3476313M1	6		16	Ring, Snap	Anneau d'arrêt	Anillo de resorte
6	6194010M91	2		4	Spider Assy	Ensemble croisillon	Cruceta, Conj.
7	3476312M1	2		2	Shaft	Arbre	Árbol
8	3523329M1			2	Spacer	Entretoise	Travesa

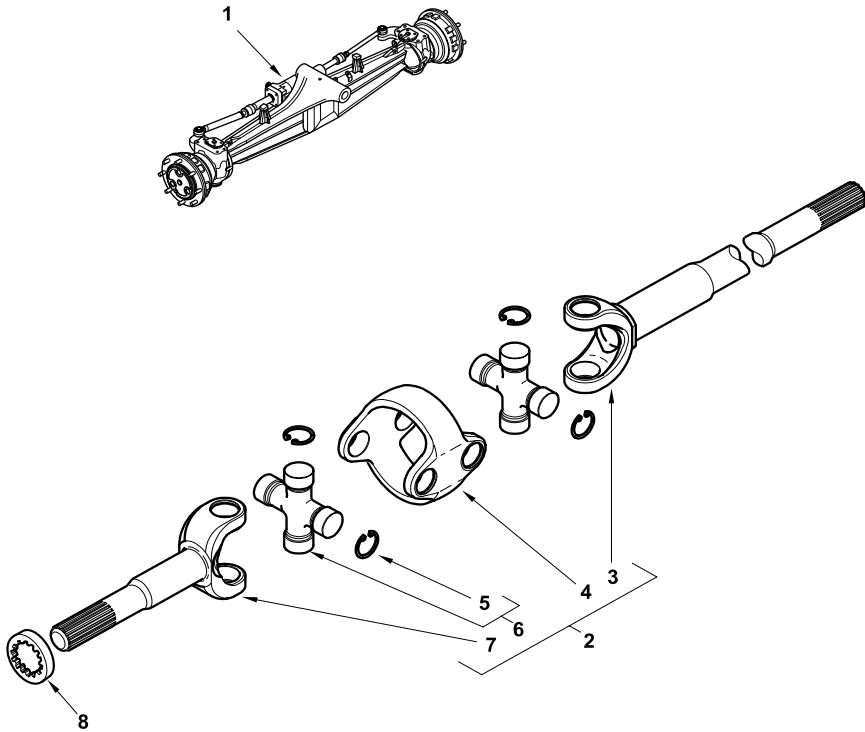

820 860 880
TX760B TX860B
TX870B

803 804 813 814 815 816 817 841 842 843 844 845

16016C06.1

6199042M3

1

Jan-06

Front Axle
Pont Avant
Puente delantero

Installation
Montage
Instalación

2 Wheel Steer
 2 Roues Directrices
 Dirección en 2 ruedas

C-16016-07.1-C

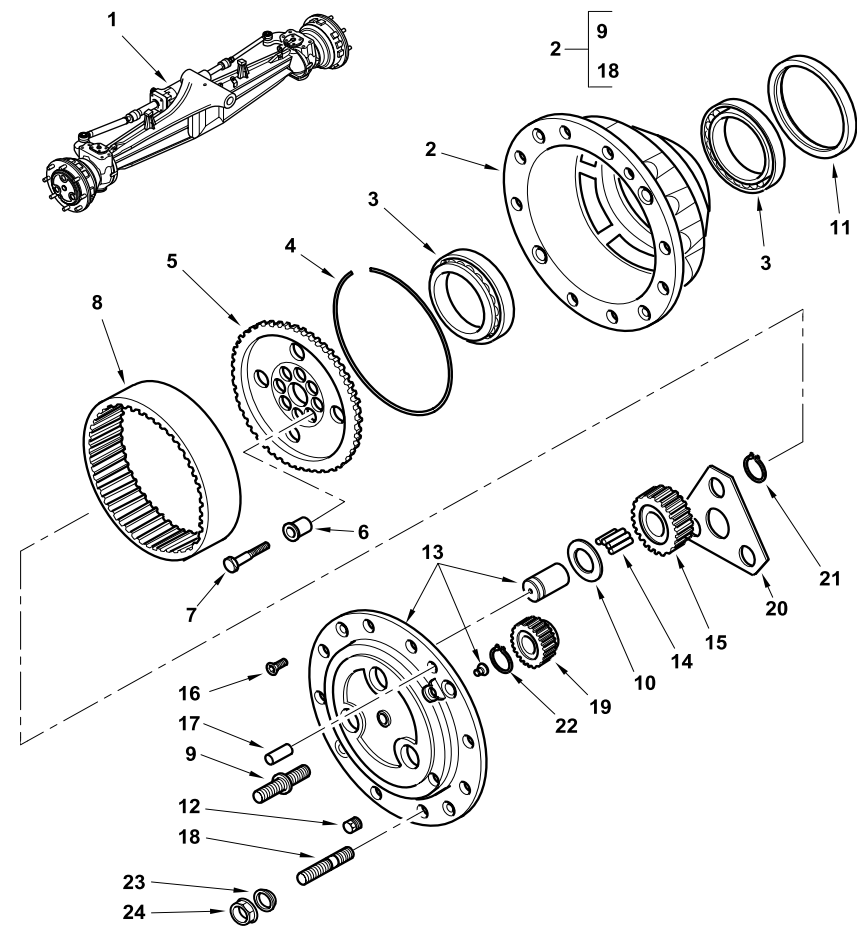

1	6110552M91		1	Axle Assy, Front	Montage d'essieu, avant	Puente delantero, Conj.
2	6193331M91		2	Kit, Wheel Hub	Jeu, moyeu de roue	Juego, Cubo de rueda
3	3475599M1		4	Bearing, Ball	Roulement à billes	Cojinete de bolas
4	3523070M1		2	Ring	Anneau	Aro
5	6193434M1		2	Carrier	Support	Portador
6	3523272M1	dia 20	16	Bushing	Bague	Anillo
7	3475604M1	M14 x 65	16	Screw	Vis	Tornillo
8	3523072M1		2	Ring, Gear	Couronne dentée	Corona dentada
9	3475613M1	2	12	Stud	Goujon	Espárrago
10	3475625M1		6	Washer	Rondelle	Arandela
11	6193704M1		2	Seal, Ring	Joint, anneau	Junta de anillo
12	3475329M1	M22	2	Plug	Bouchon	Tapón
13	3523905M91		2	Carrier, Pinion	Porte-satellites	Portasatélites
14	3523075M1		18	Needle	Aiguille	Aguja
15	3475610M1		6	Gear	Pignon	Piñón
16	3475622M1	M12 x 30	4	Screw	Vis	Tornillo
17	3475618M1		4	Pin	Axe	Pasador
18	3475614M1	2	4	Stud	Goujon	Espárrago
19	3475594M1		2	Gear	Pignon	Piñón
20	3523073M1		2	Bearing, Support	Palier support	Palier soporte
21	3523098M1		6	Ring, Snap	Anneau d'arrêt	Anillo de resorte
22	3475595M1		2	Ring, Snap	Anneau d'arrêt	Anillo de resorte
23	3475615M1		16	Washer	Rondelle	Arandela
24	3475616M1		16	Nut	Écrou	Tuerca



820 860 880
 TX760B TX860B
 TX870B

803 804 813 814 815 816 817 841 842 843 844 845

16016C07.1

6199042M3

1

Jan-06

Front Axle
Pont Avant
Puente delantero

Steering Pivot
Pivot de Direction
Pivote de dirección

2 Wheel Drive
2 Roues Motrices
2 ruedas motrices

C-16010-03.1-B

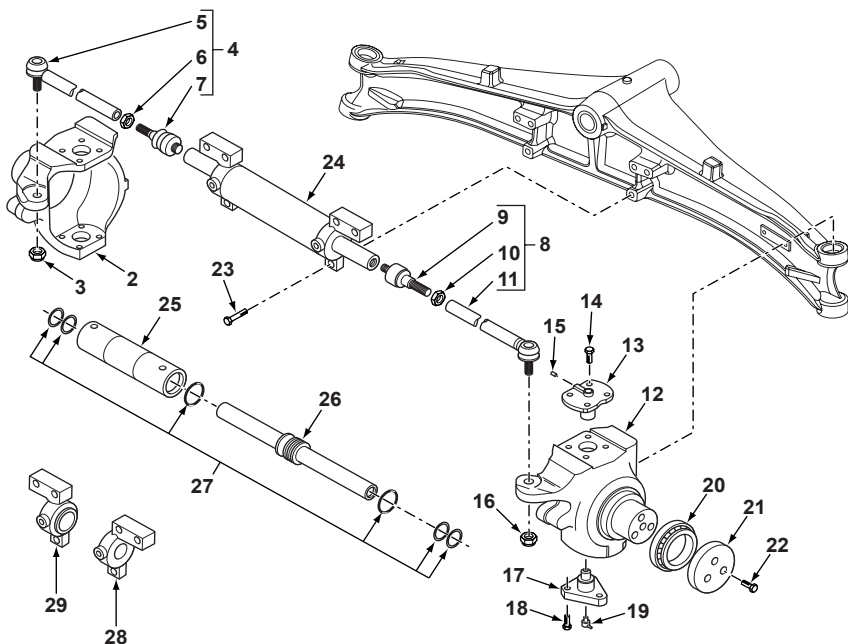

1	6109606M91		Ref: 148394	1	Axle Assy, Front	Montage d'essieu, avant	Puente delantero, Conj.
2	6194094M1	1	◀	1	Housing, Swivel	Carter, pivot	Cárter, junta giratoria
3	6194096M1	1	M18	1	Nut	Écrou	Tuerca
4	6194097M91	1		1	Arm Assy	Ensemble de bras	Brazo, Conj.
5	6194098M91	4		1	Tie Rod Assy	Barre direction, mont.	Barra dirección, Conj.
6	6194099M1	4	M18	1	Nut	Écrou	Tuerca
7	6194100M1	4		1	Ball Joint	Rotule	Rotula
8	6194097M91	1		1	Arm Assy	Ensemble de bras	Brazo, Conj.
9	6194100M1	8		1	Ball Joint	Rotule	Rotula
10	6194099M1	8	M18	1	Nut	Écrou	Tuerca
11	6194098M91	8		1	Tie Rod Assy	Barre direction, mont.	Barra dirección, Conj.
12	6194095M1	1	▶	1	Housing, Swivel	Carter, pivot	Cárter, junta giratoria
13	6194104M1	1		2	Pin	Axe	Pasador
14	6194103M1	1	M12 x 30	8	Bolt	Boulon	Perno
15	6190567M1	1		2	Fitting, Grease	Graisseur	Engrasador
16	6194096M1	1	M18	1	Nut	Écrou	Tuerca
17	6190566M1	1		2	Pin	Axe	Pasador
18	3523548M1	1	M14 x 35	6	Screw	Vis	Tornillo
19	6194111M1	1		2	Fitting, Grease	Graisseur	Engrasador
20	6194105M91	1		2	Bearing Assy	Roulement	Rodamiento, Conj.
21	6194106M1	1		2	Washer, Thrust	Rondelle de butée	Arandela de tope
22	6194103M1	1	M12 x 30	6	Bolt	Boulon	Perno
23	6194102M1	1	M16 x 70	6	Bolt	Boulon	Perno
24	6194101M91	1	👁 17001C01.1	25	Cylinder, Steering	Vérin de direction	Gato de dirección
25		24	➡ Ref: 24	1	Cylinder	Cylindre	Cilindro
26	6194108M91	24		1	Rod Assy	Ensemble tringlerie	Tirantes, Conj.
27	6194107M91	24		1	Kit, Seal	Pochette de joints	Juego de juntas
28	6194109M91	24	▶	1	Head Assy	Ensemble de tête	Cabeza, Conj.
29	6194110M91	24	◀	1	Head Assy	Ensemble de tête	Cabeza, Conj.



820
 TX760B TX860B

801 802 805 806 809 810

16010C03.1

6199042M3

1

Jan-06

Front Axle
Pont Avant
Puente delantero

Steering Pivot
Pivot de Direction
Pivote de dirección

4 Wheel Drive
4 Roues Motrices
4 ruedas motrices

C-16011-05.1-B

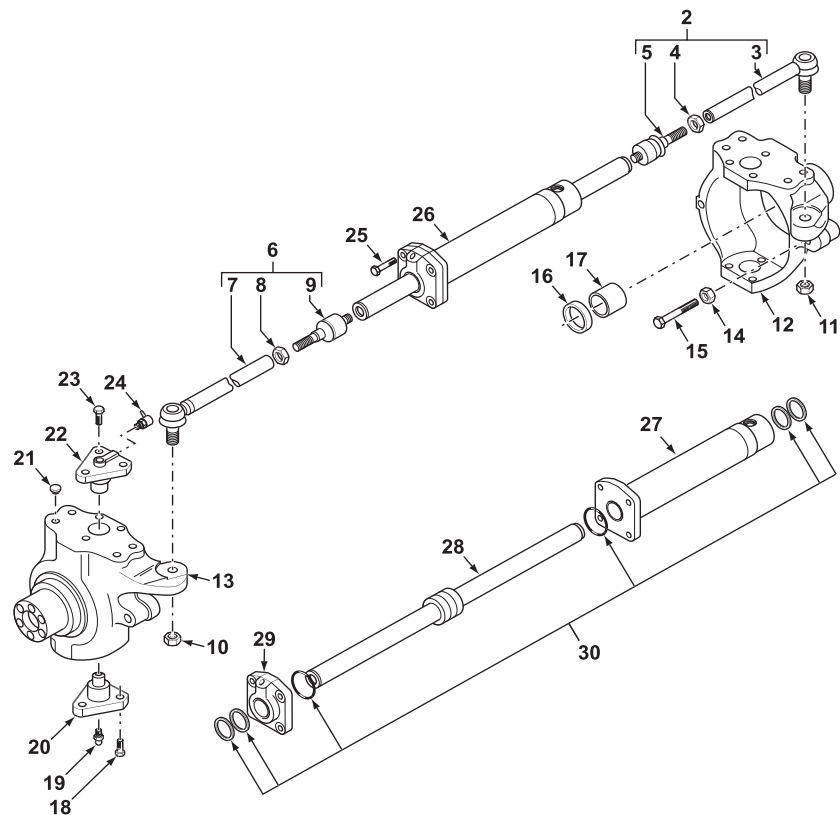

1	6109000M91		Ref: 148092	1	Axle Assy, Front	Montage d'essieu, avant	Puente delantero, Conj.
2	6194019M91	1		1	Arm Assy	Ensemble de bras	Brazo, Conj.
3	6194011M91	2		1	Tie Rod Assy	Barre direction, mont.	Barra dirección, Conj.
4	6193677M1	2	M24	1	Nut	Écrou	Tuerca
5	6194012M1	2		1	Ball Joint	Rotule	Rotula
6	6194019M91	1		1	Arm Assy	Ensemble de bras	Brazo, Conj.
7	6194011M91	6		1	Tie Rod Assy	Barre direction, mont.	Barra dirección, Conj.
8	6193677M1	6	M24	1	Nut	Écrou	Tuerca
9	6194012M1	6		1	Ball Joint	Rotule	Rotula
10	6190221M1	1	M20	1	Nut	Écrou	Tuerca
11	6190221M1	1	M20	1	Nut	Écrou	Tuerca
12	6194028M1	1	▶	1	Housing, Swivel	Carter, pivot	Cárter, junta giratoria
13	6194029M1	1	◀	1	Housing, Swivel	Carter, pivot	Cárter, junta giratoria
14	6194005M1	1	M16	2	Nut	Écrou	Tuerca
15	6194020M1	1	M16 x 100	2	Bolt	Boulon	Perno
16	3475534M1	1	35 x 52 x 16 mm	2	Seal	Joint	Junta
17	3475535M1	1		2	Bushing	Bague	Anillo
18	3523548M1	1	M14 x 35	6	Screw	Vis	Tornillo
19	6190567M1	1		2	Fitting, Grease	Graisneur	Engrasador
20	6190566M1	1		2	Pin	Axe	Pasador
21	6194007M1	1		8	Plug	Bouchon	Tapón
22	6190565M1	1		2	Pin	Axe	Pasador
23	3523548M1	1	M14 x 35	6	Screw	Vis	Tornillo
24	6193432M1	1		2	Fitting, Grease	Graisneur	Engrasador
25	6194024M1	1	M12 x 45	4	Bolt	Boulon	Perno
26	6194023M91	1	17001C01.1	25	Cylinder, Steering	Vérin de direction	Gato de dirección
27		26		1	Cylinder	Cylindre	Cilindro
28	6194013M1	26		1	Rod	Tringle	Vástago
29	6194014M1	26		1	Head, Cylinder	Culasse	Culata
30	6194015M91	26		1	Kit, Seal	Pochette de joints	Juego de juntas



820
TX760B

807 808 833 834

16011C05.1

6199042M3

1

Jan-06

Front Axle
Pont Avant
Puente delantero

Steering Pivot
Pivot de Direction
Pivote de dirección

4 Wheel Drive
4 Roues Motrices
4 ruedas motrices

C-16012-05.1-B

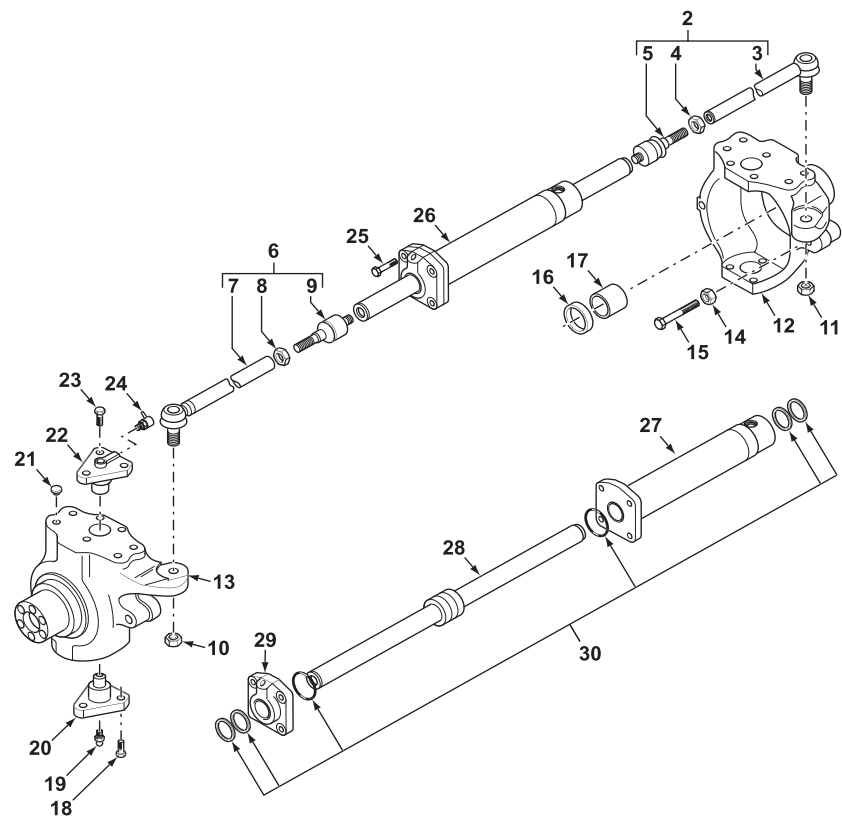

1	6109144M91		Ref: 148093	1	Axle Assy, Front	Montage d'essieu, avant	Puente delantero, Conj.
2	6194019M91	1		1	Arm Assy	Ensemble de bras	Brazo, Conj.
3	6194011M91	2		1	Tie Rod Assy	Barre direction, mont.	Barra dirección, Conj.
4	6193677M1	2	M24	1	Nut	Écrou	Tuerca
5	6194012M1	2		1	Ball Joint	Rotule	Rotula
6	6194019M91	1		1	Arm Assy	Ensemble de bras	Brazo, Conj.
7	6194011M91	6		1	Tie Rod Assy	Barre direction, mont.	Barra dirección, Conj.
8	6193677M1	6	M24	1	Nut	Écrou	Tuerca
9	6194012M1	6		1	Ball Joint	Rotule	Rotula
10	6190221M1	1	M20	1	Nut	Écrou	Tuerca
11	6190221M1	1	M20	1	Nut	Écrou	Tuerca
12	6194028M1	1	▶	1	Housing, Swivel	Carter, pivot	Cárter, junta giratoria
13	6194029M1	1	◀	1	Housing, Swivel	Carter, pivot	Cárter, junta giratoria
14	6194005M1	1	M16	2	Nut	Écrou	Tuerca
15	6194020M1	1	M16 x 100	2	Bolt	Boulon	Perno
16	3475534M1	1	35 x 52 x 16 mm	2	Seal	Joint	Junta
17	3475535M1	1		2	Bushing	Bague	Anillo
18	3523548M1	1	M14 x 35	6	Screw	Vis	Tornillo
19	6190567M1	1		2	Fitting, Grease	Graisneur	Engrasador
20	6190566M1	1		2	Pin	Axe	Pasador
21	6194007M1	1		8	Plug	Bouchon	Tapón
22	6190565M1	1		2	Pin	Axe	Pasador
23	3523548M1	1	M14 x 35	6	Screw	Vis	Tornillo
24	6193432M1	1		2	Fitting, Grease	Graisneur	Engrasador
25	6194024M1	1	M12 x 45	4	Bolt	Boulon	Perno
26	6194023M91	1	👁️ 17001C01.1	25	Cylinder, Steering	Vérin de direction	Gato de dirección
27		26	➡️ Ref. 26	1	Cylinder	Cylindre	Cilindro
28	6194013M1	26		1	Rod	Tringle	Vástago
29	6194014M1	26		1	Head, Cylinder	Culasse	Culata
30	6194015M91	26		1	Kit, Seal	Pochette de joints	Juego de juntas



820 860 880
 TX760B TX860B
 TX870B

803 804 813 814 815 816 817 831 832 841 842 843 844 845

16012C05.1

6199042M3

1

Jan-06

Front Axle
Pont Avant
Puente delantero

Steering Pivot
Pivot de Direction
Pivote de dirección

4 Wheel Drive
4 Roues Motrices
4 ruedas motrices

C-16013-05.1-B

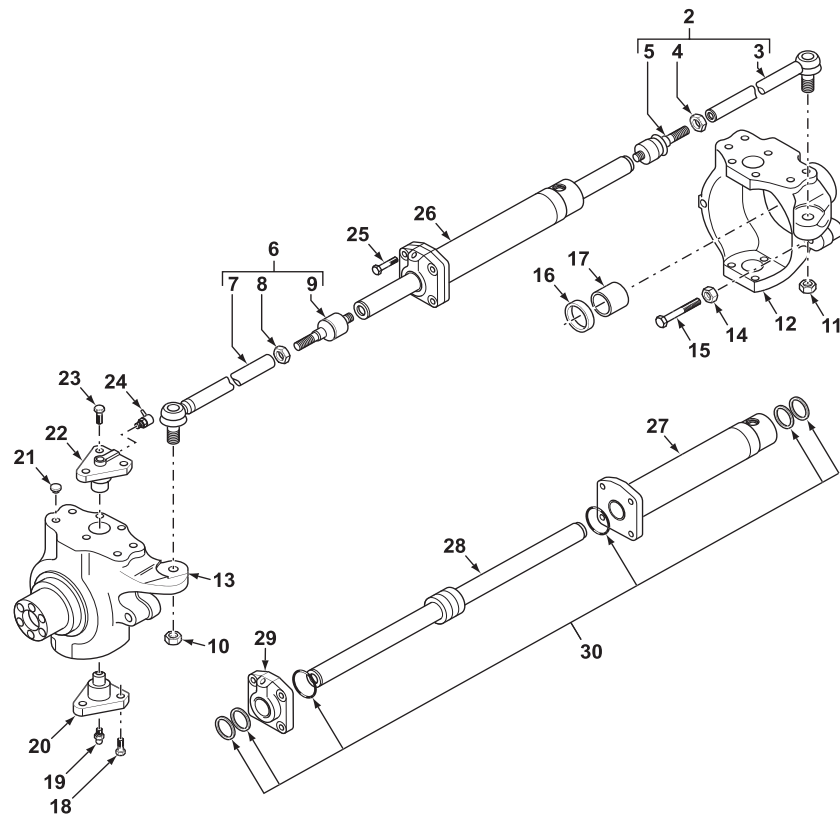

1	6109145M91		Ref: 148648	1	Axle Assy, Front	Montage d'essieu, avant	Puente delantero, Conj.
2	6194019M91	1		1	Arm Assy	Ensemble de bras	Brazo, Conj.
3	6194011M91	2		1	Tie Rod Assy	Barre direction, mont.	Barra dirección, Conj.
4	6193677M1	2	M24	1	Nut	Écrou	Tuerca
5	6194012M1	2		1	Ball Joint	Rotule	Rotula
6	6194019M91	1		1	Arm Assy	Ensemble de bras	Brazo, Conj.
7	6194011M91	6		1	Tie Rod Assy	Barre direction, mont.	Barra dirección, Conj.
8	6193677M1	6	M24	1	Nut	Écrou	Tuerca
9	6194012M1	6		1	Ball Joint	Rotule	Rotula
10	6190221M1	1	M20	1	Nut	Écrou	Tuerca
11	6190221M1	1	M20	1	Nut	Écrou	Tuerca
12	6194028M1	1	▶	1	Housing, Swivel	Carter, pivot	Cárter, junta giratoria
13	6194029M1	1	◀	1	Housing, Swivel	Carter, pivot	Cárter, junta giratoria
14	6194005M1	1	M16	2	Nut	Écrou	Tuerca
15	6194020M1	1	M16 x 100	2	Bolt	Boulon	Perno
16	3475534M1	1	35 x 52 x 16 mm	2	Seal	Joint	Junta
17	3475535M1	1		2	Bushing	Bague	Anillo
18	3523548M1	1	M14 x 35	6	Screw	Vis	Tornillo
19	6190567M1	1		2	Fitting, Grease	Graisneur	Engrasador
20	6190566M1	1		2	Pin	Axe	Pasador
21	6194007M1	1		8	Plug	Bouchon	Tapón
22	6190565M1	1		2	Pin	Axe	Pasador
23	3523548M1	1	M14 x 35	6	Screw	Vis	Tornillo
24	6193432M1	1		2	Fitting, Grease	Graisneur	Engrasador
25	6194024M1	1	M12 x 45	4	Bolt	Boulon	Perno
26	6194023M91	1	👁 17001C01.1	25	Cylinder, Steering	Vérin de direction	Gato de dirección
27		26	👁 Ref. 26	1	Cylinder	Cylindre	Cilindro
28	6194013M1	26		1	Rod	Tringle	Vástago
29	6194014M1	26		1	Head, Cylinder	Culasse	Culata
30	6194015M91	26		1	Kit, Seal	Pochette de joints	Juego de juntas



860 880
TX860B TX870B

821 822 823 824 825 851 852 853 854 855

16013C05.1

6199042M3

1

Jan-06

Front Axle
Pont Avant
Puente delantero

Steering Pivot
Pivot de Direction
Pivote de dirección

4 Wheel Steer
4 Roues Directrices
Dirección en las 4 ruedas

C-16014-05.1-B

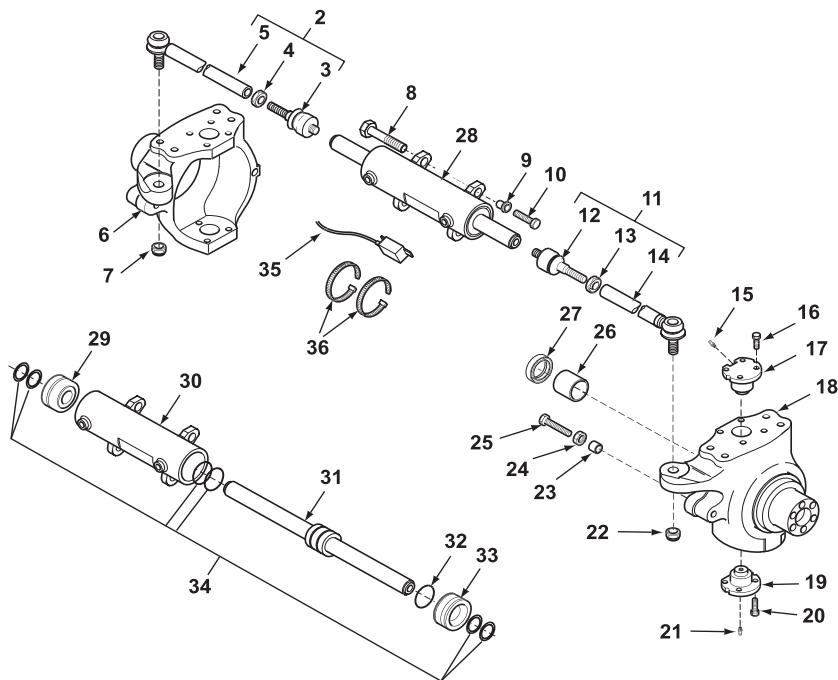

1	6109146M91		Continued Ref: 148930	1	Axle Assy, Front	Montage d'essieu, avant	Puente delantero, Conj.
2	6194264M91	1		1	Arm Assy	Ensemble de bras	Brazo, Conj.
3	6194265M91	2		1	Ball Joint Assy	Ensemble de rotule	Rotula, Conj.
4	6193677M1	2	M24	1	Nut	Écrou	Tuerca
5	6194266M91	2		1	Tie Rod Assy	Barre direction, mont.	Barra dirección, Conj.
6	6194268M1	1	◀	1	Housing, Swivel	Carter, pivot	Cárter, junta giratoria
7	6194269M1	1	M24 x 1.5	1	Nut	Écrou	Tuerca
8	6194270M1	1	M18 x 50	2	Bolt	Boulon	Perno
9	6193682M1	1		2	Bush	Bague	Casquillo
10	3475604M1	1	M14 x 65	2	Screw	Vis	Tornillo
11	6194264M91	1		1	Arm Assy	Ensemble de bras	Brazo, Conj.
12	6194265M91	1		1	Ball Joint Assy	Ensemble de rotule	Rotula, Conj.
13	6193677M1	1	M24	1	Nut	Écrou	Tuerca
14	6194266M91	1		1	Tie Rod Assy	Barre direction, mont.	Barra dirección, Conj.
15	6190567M1	1		2	Fitting, Grease	Graisser	Engrasador
16	3523597M1	1	M16 x 38	8	Screw	Vis	Tornillo
17	6194275M1	1		2	Pin, King	Axe de pivotement	Pasador principal
18	6194274M1	1	▶	1	Housing, Swivel	Carter, pivot	Cárter, junta giratoria
19	6193283M1	1		2	Pin, King	Axe de pivotement	Pasador principal
20	3523597M1	1	M16 x 38	8	Screw	Vis	Tornillo
21	6190567M1	1		2	Fitting, Grease	Graisser	Engrasador
22	6194269M1	1	M24 x 1.5	1	Nut	Écrou	Tuerca
23	6194273M1	1		4	Bush	Bague	Casquillo
24	6194272M1	1	M16	4	Nut	Écrou	Tuerca
25	6194271M1	1	M16 x 130	4	Bolt	Boulon	Perno
26	6190264M1	1		2	Bushing	Bague	Anillo
27	6193448M1	1		2	Seal	Joint	Junta
28	6194267M91	1	👁 17002C01.1	26	Cylinder, Steering	Vérin de direction	Gato de dirección
29	6193684M1	28		1	Head, Cylinder	Culasse	Culata
30		28	🔩 Ref. 28	1	Cylinder	Cylindre	Cilindro
31	6193683M91	28		1	Rod Assy	Ensemble tringlerie	Tirantes, Conj.
32	6194277M1	28	Magnetic	1	Ring, Special	Jonc	Junquillo
33	6193684M1	28		1	Head, Cylinder	Culasse	Culata
34	6193685M91	28		1	Kit, Seal	Pochette de joints	Juego de juntas
35	6194276M91	1		1	Sensor	Capteur	Captador
36	6194287M1	1		2	Clamp	Collier de serrage	Argolla de cierre



970 980
TX970B

921 922 923 931 932

16014C05.1

6199042M3

1

Jan-06

Front Axle
Pont Avant
Puente delantero

Wheel Hub
Moyeu de Roue
Cubo de rueda

2 Wheel Drive
2 Roues Motrices
2 ruedas motrices

C-16010-04.1-A

1	6109606M91	Ref: 148394	1	Axle Assy, Front	Montage d'essieu, avant	Puente delantero, Conj.
2	6194112M1		2	Seal, Ring	Joint, anneau	Junta de anillo
3	6194113M91		2	Bearing Assy	Roulement	Rodamiento, Conj.
4	6194114M1		2	Wheel Hub, Assy	Moyen roue, montage	Cubo de rueda, Conj.
5	6194115M1		2	O-Ring	Joint torique	Junta de tipo O
6	6194116M1		2	Cover	Cache	Tapa
7	3523998M1	M10 x 1	2	Plug	Bouchon	Tapón

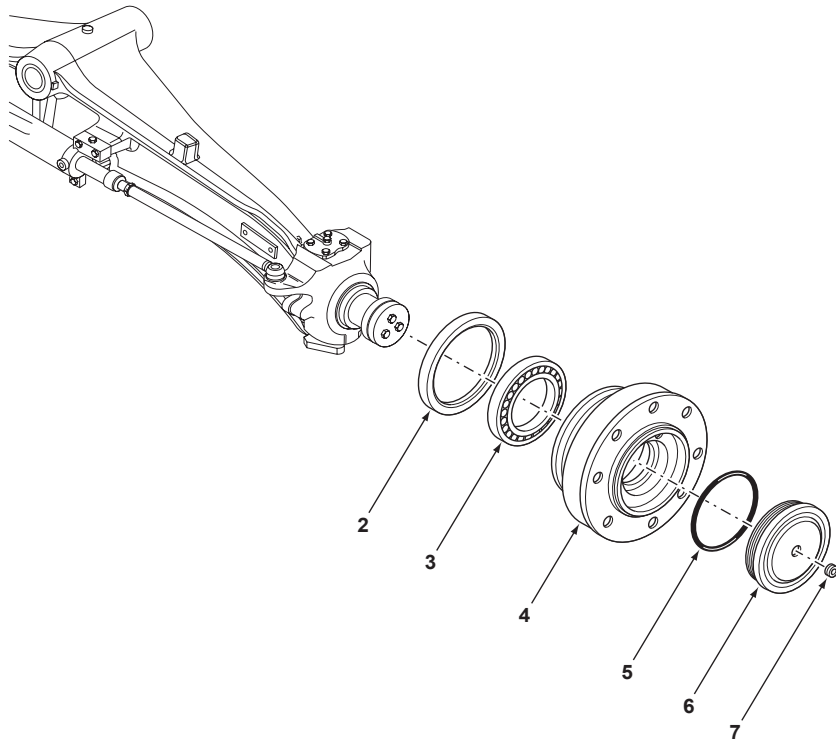

820
TX760B TX860B

801 802 805 806 809 810

16010C04.1

6199042M3

1

Jan-06

Front Axle
Pont Avant
Puente delantero

Wheel Hub
Moyeu de Roue
Cubo de rueda

4 Wheel Drive
4 Roues Motrices
4 ruedas motrices

C-16011-07.1-A

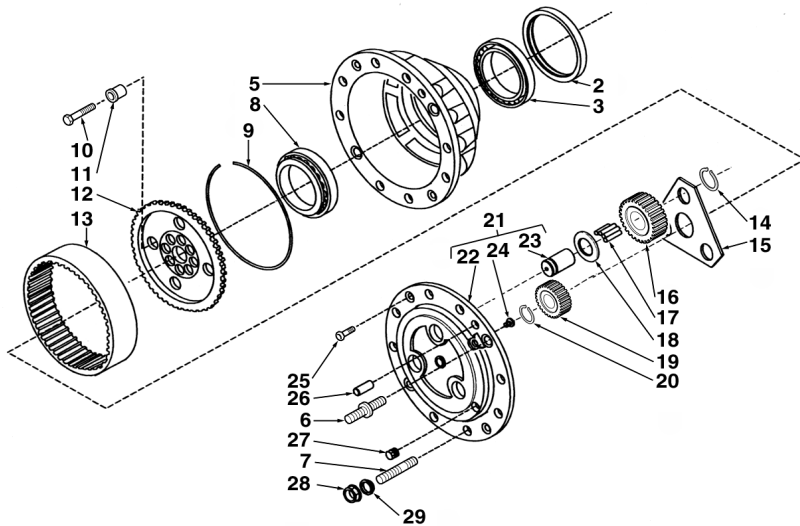

1	6109000M91		Ref: 148092	1	Axle Assy, Front	Montage d'essieu, avant	Puente delantero, Conj.
2	6193704M1	1		2	Seal, Ring	Joint, anneau	Junta de anillo
3	3475599M1	1		2	Bearing, Ball	Roulement à billes	Cojinete de bolas
4	6193331M91	1		2	Kit, Wheel Hub	Jeu, moyeu de roue	Juego, Cubo de rueda
5		4	➡ Ref. 4	1	Hub	Moyeu	Cubo
6	3475614M1	4		2	Stud	Goujon	Espárrago
7	3475613M1	4		6	Stud	Goujon	Espárrago
8	3475599M1	1		2	Bearing, Ball	Roulement à billes	Cojinete de bolas
9	3523070M1	1		2	Ring	Anneau	Aro
10	3475604M1	1	M14 x 65	16	Screw	Vis	Tornillo
11	3523272M1	1	dia 20	16	Bushing	Bague	Anillo
12	6193434M1	1		2	Carrier	Support	Portador
13	3523072M1	1		2	Ring, Gear	Couronne dentée	Corona dentada
14	3523098M1	1		6	Ring, Snap	Anneau d'arrêt	Anillo de resorte
15	3523073M1	1		2	Bearing, Support	Palier support	Palier soporte
16	3523074M1	1		6	Gear, Planetary	Planétaire	Piñón planetario
17	3523075M1	1		18	Needle	Aiguille	Aguja
18	3475625M1	1		6	Washer	Rondelle	Arandela
19	3475594M1	1		2	Gear	Pignon	Piñón
20	3475595M1	1		2	Ring, Snap	Anneau d'arrêt	Anillo de resorte
18	3475625M1	1		6	Washer	Rondelle	Arandela
21	3523905M91	1		2	Carrier, Pinion	Porte-satellites	Portasatélites
22		21	➡ Ref. 21	1	Carrier	Support	Portador
23		21	➡ Ref. 21	3	Shaft	Arbre	Árbol
24		21	➡ Ref. 21	1	Pad	Plaque antidérapante	Cinta antideslizante
25	3475622M1	1	M12 x 30	4	Screw	Vis	Tornillo
26	3475618M1	1		4	Pin	Axe	Pasador
27	3475329M1	1	M22	2	Plug	Bouchon	Tapón
28	3475616M1	1		16	Nut	Écrou	Tuerca
29	3475615M1	1		16	Washer	Rondelle	Arandela



820
TX760B

807 808 833 834

16011C07.1

6199042M3

1

Jan-06

Front Axle
Pont Avant
Puente delantero

Wheel Hub
Moyeu de Roue
Cubo de rueda

4 Wheel Drive
4 Roues Motrices
4 ruedas motrices

C-16012-07.1-A

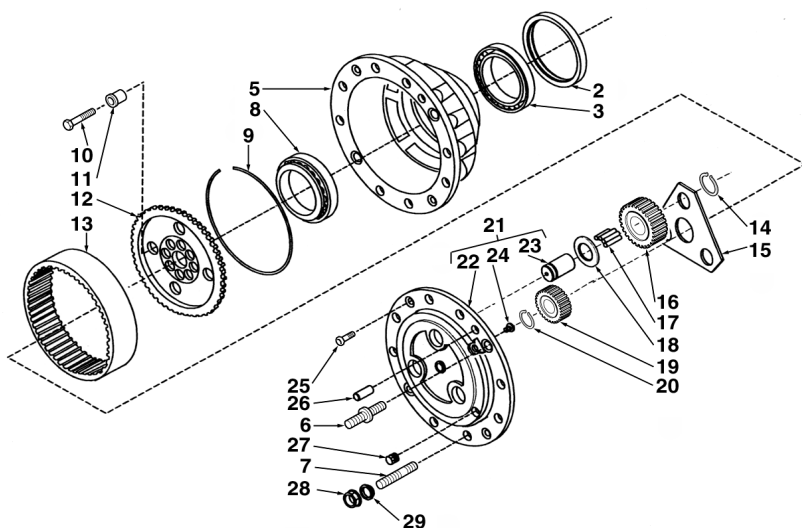

1	6109144M91		Ref: 148093	1	Axle Assy, Front	Montage d'essieu, avant	Puente delantero, Conj.
2	6193704M1	1		2	Seal, Ring	Joint, anneau	Junta de anillo
3	3475599M1	1		2	Bearing, Ball	Roulement à billes	Cojinete de bolas
4	6193331M91	1		2	Kit, Wheel Hub	Jeu, moyeu de roue	Juego, Cubo de rueda
5		4	➡ Ref. 4	1	Hub	Moyeu	Cubo
6	3475614M1	4		2	Stud	Goujon	Espárrago
7	3475613M1	4		6	Stud	Goujon	Espárrago
8	3475599M1	1		2	Bearing, Ball	Roulement à billes	Cojinete de bolas
9	3523070M1	1		2	Ring	Anneau	Aro
10	3475604M1	1	M14 x 65	16	Screw	Vis	Tornillo
11	3523272M1	1	dia 20	16	Bushing	Bague	Anillo
12	6193434M1	1		2	Carrier	Support	Portador
13	3523072M1	1		2	Ring, Gear	Couronne dentée	Corona dentada
14	3523098M1	1		6	Ring, Snap	Anneau d'arrêt	Anillo de resorte
15	3523073M1	1		2	Bearing, Support	Palier support	Palier soporte
16	3475610M1	1		6	Gear	Pignon	Piñón
17	3523075M1	1		18	Needle	Aiguille	Aguja
18	3475625M1	1		6	Washer	Rondelle	Arandela
19	3475594M1	1		2	Gear	Pignon	Piñón
20	3475595M1	1		2	Ring, Snap	Anneau d'arrêt	Anillo de resorte
18	3475625M1	1		6	Washer	Rondelle	Arandela
21	6190817M91	1		2	Carrier, Pinion	Porte-satellites	Portasatélites
22		21	➡ Ref. 21	1	Carrier	Support	Portador
23		21	➡ Ref. 21	3	Shaft	Arbre	Árbol
24		21	➡ Ref. 21	1	Pad	Plaque antidérapante	Cinta antideslizante
25	3475622M1	1	M12 x 30	4	Screw	Vis	Tornillo
26	3475618M1	1		4	Pin	Axe	Pasador
27	3475329M1	1	M22	2	Plug	Bouchon	Tapón
28	3475616M1	1		16	Nut	Écrou	Tuerca
29	3475615M1	1		16	Washer	Rondelle	Arandela



820 860 880
TX760B TX860B
TX870B

803 804 813 814 815 816 817 831 832 841 842 843 844 845

16012C07.1

6199042M3

1

Jan-06

Front Axle
Pont Avant
Puente delantero

Wheel Hub
Moyeu de Roue
Cubo de rueda

4 Wheel Drive
4 Roues Motrices
4 ruedas motrices

C-16013-07.1-A

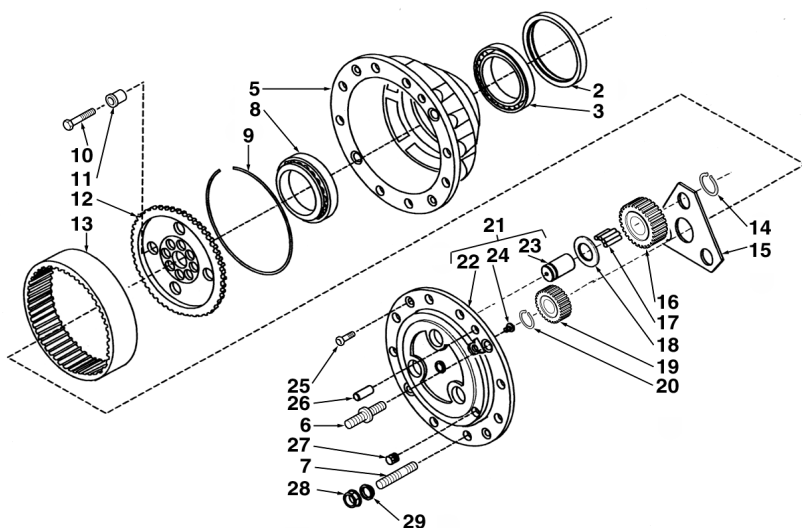

1	6109145M91		Ref: 148648	1	Axle Assy, Front	Montage d'essieu, avant	Puente delantero, Conj.
2	6193704M1	1		2	Seal, Ring	Joint, anneau	Junta de anillo
3	3475599M1	1		2	Bearing, Ball	Roulement à billes	Cojinete de bolas
4	6193331M91	1		2	Kit, Wheel Hub	Jeu, moyeu de roue	Juego, Cubo de rueda
5		4	➡ Ref. 4	1	Hub	Moyeu	Cubo
6	3475614M1	4		2	Stud	Goujon	Espárrago
7	3475613M1	4		6	Stud	Goujon	Espárrago
8	3475599M1	1		2	Bearing, Ball	Roulement à billes	Cojinete de bolas
9	3523070M1	1		2	Ring	Anneau	Aro
10	3475604M1	1	M14 x 65	16	Screw	Vis	Tornillo
11	3523272M1	1	dia 20	16	Bushing	Bague	Anillo
12	6193434M1	1		2	Carrier	Support	Portador
13	3523072M1	1		2	Ring, Gear	Couronne dentée	Corona dentada
14	3523098M1	1		6	Ring, Snap	Anneau d'arrêt	Anillo de resorte
15	3523073M1	1		2	Bearing, Support	Palier support	Palier soporte
16	3475610M1	1		6	Gear	Pignon	Piñón
17	3523075M1	1		18	Needle	Aiguille	Aguja
18	3475625M1	1		6	Washer	Rondelle	Arandela
19	3475594M1	1		2	Gear	Pignon	Piñón
20	3475595M1	1		2	Ring, Snap	Anneau d'arrêt	Anillo de resorte
18	3475625M1	1		6	Washer	Rondelle	Arandela
21	6190817M91	1		2	Carrier, Pinion	Porte-satellites	Portasatélites
22		21	➡ Ref. 21	1	Carrier	Support	Portador
23		21	➡ Ref. 21	3	Shaft	Arbre	Árbol
24		21	➡ Ref. 21	1	Pad	Plaque antidérapante	Cinta antideslizante
25	3475622M1	1	M12 x 30	4	Screw	Vis	Tornillo
26	3475618M1	1		4	Pin	Axe	Pasador
27	3475329M1	1	M22	2	Plug	Bouchon	Tapón
28	3475616M1	1		16	Nut	Écrou	Tuerca
29	3475615M1	1		16	Washer	Rondelle	Arandela



860 880
TX860B TX870B

821 822 823 824 825 851 852 853 854 855

16013C07.1

6199042M3

1

Jan-06

Front Axle
Pont Avant
Puente delantero

Wheel Hub
Moyeu de Roue
Cubo de rueda

4 Wheel Steer
4 Roues Directrices
Dirección en las 4 ruedas

C-16014-07.1-A

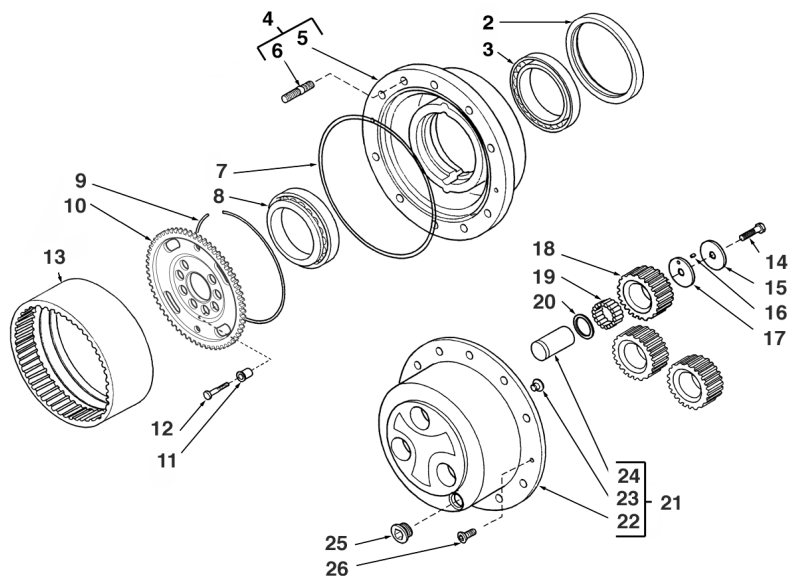

1	6109146M91		Continued Ref: 148930	1	Axle Assy, Front	Montage d'essieu, avant	Puente delantero, Conj.
2	6193704M1	1		2	Seal, Ring	Joint, anneau	Junta de anillo
3	3475599M1	1		4	Bearing, Ball	Roulement à billes	Cojinete de bolas
4	6194284M91	1		2	Wheel Hub, Assy	Moyen roue, montage	Cubo de rueda, Conj.
5		4	➡ Ref. 4	1	Hub	Moyeu	Cubo
6	6190302M1	4		10	Stud	Goujon	Espárrago
7	6193409M1	1		2	O-Ring	Joint torique	Junta de tipo O
8	3475599M1	1		2	Bearing, Ball	Roulement à billes	Cojinete de bolas
9	6190290M1	1		2	Ring, Retaining	Anneau de retenue	Anillo de retención
10	6193411M1	1		2	Carrier	Support	Portador
11	3523272M1	1	dia 20	16	Bushing	Bague	Anillo
12	3475604M1	1	M14 x 65	16	Screw	Vis	Tornillo
13	6194285M1	1		2	Gear	Pignon	Piñón
14	6190283M1	1	M10 x 50	6	Screw	Vis	Tornillo
15	6190289M1	1		6	Washer	Rondelle	Arandela
16	6193417M1	1		6	Needle	Aiguille	Aguja
17	6190288M1	1		6	Washer, Thrust	Rondelle de butée	Arandela de tope
18	6190286M1	1		6	Gear	Pignon	Piñón
19	6190285M1	1		X	Needle	Aiguille	Aguja
20	6190284M1	1		6	Washer, Thrust	Rondelle de butée	Arandela de tope
21	6194286M91	1		2	Carrier, Planetary	Porte-planétaires	Portaplanetarios
22		21	➡ Ref. 21	1	Carrier	Support	Portador
23		21	➡ Ref. 21	1	Pin	Axe	Pasador
24		21	➡ Ref. 21	3	Pin	Axe	Pasador
25	3523632M1	1	M30 x 2	2	Plug	Bouchon	Tapón
26	6190282M1	1	M8 x 20	4	Screw	Vis	Tornillo



970 980
TX970B

921 922 923 931 932

16014C07.1

6199042M3

1

Jan-06

Steering System
Direction
Dirección

2 Wheel Steer
 2 Roues Directrices
 Dirección en 2 ruedas

C-17001-01.1-A

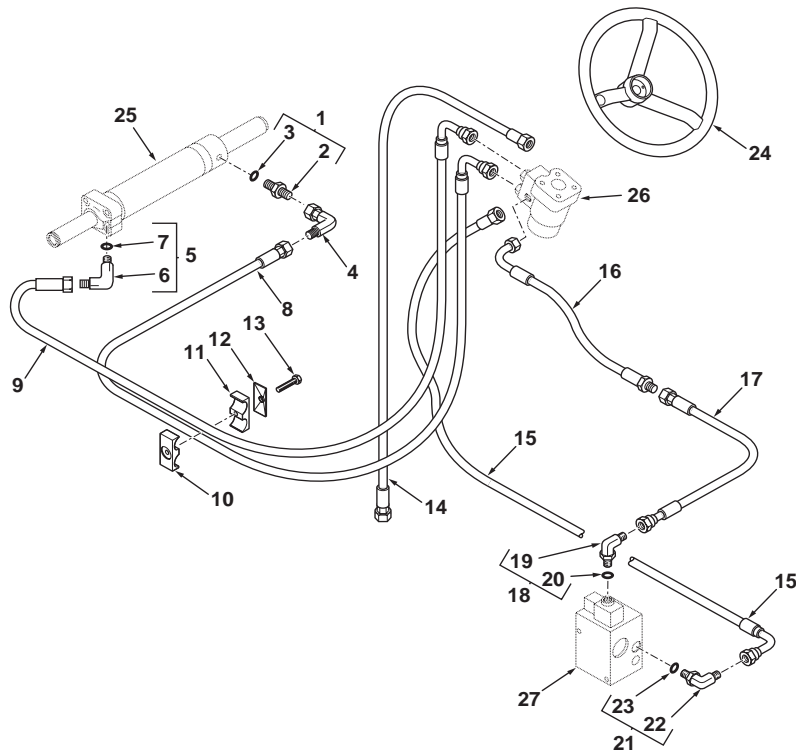

1	835091M91	9/16	1	Union	Union	Unión
2		1	1	Union	Union	Unión
3	831452M1	1	1	O-Ring	Joint torique	Junta de tipo O
4	364603X1	9/16	1	Elbow, 90°	Coude à 90°	Codo, 90°
5	358781X91		1	Elbow, 45°	Coude à 45°	Codo, 45°
6		5	1	Elbow	Coude	Codo
7		5	1	O-Ring	Joint torique	Junta de tipo O
8	6109247M91		1	Hose Assy	Ensemble de flexible	Flexible, Conj.
9	6109246M91		1	Hose Assy	Ensemble de flexible	Flexible, Conj.
10	1470377M1		1	Bracket, Clamp	Bride de fixation	Brida de fijación
11	1470377M1		1	Bracket, Clamp	Bride de fixation	Brida de fijación
12	1470376M1		1	Plate	Plaque	Placa
13	339011X1	M8 x 45	1	Bolt	Boulon	Perno
14	6109244M91		1	Hose Assy	Ensemble de flexible	Flexible, Conj.
15	6109245M91		1	Hose Assy	Ensemble de flexible	Flexible, Conj.
16	6109248M91		1	Hose Assy	Ensemble de flexible	Flexible, Conj.
17	6107914M91		1	Hose Assy	Ensemble de flexible	Flexible, Conj.
18	358760X91		1	Elbow, 90°	Coude à 90°	Codo, 90°
19		18	1	Elbow	Coude	Codo
20	831495M1	18	1	O-Ring	Joint torique	Junta de tipo O
21	835007M91		1	Elbow, 90°	Coude à 90°	Codo, 90°
22		21	1	Elbow	Coude	Codo
23	835024M1	21	1	O-Ring	Joint torique	Junta de tipo O
24	6106008M1		1	Wheel, Steering	Volant de direction	Volante de dirección
25		Front Axle, Steering Pivot	1	Cylinder Assy	Ensemble de vérin	Gato, Conj.
26		41010C03.1 18	1	Pump, Steering	Pompe, direction	Bomba, Dirección
27		Main Hydraulics	1	Valve Assy	Ensemble de soupape	Válvula, Conj.



820 860 880
 TX760B TX860B
 TX870B

801 802 803 804 805 806 807 808 809 810 813 814 815 816 817 821 822 823 824
 825 831 832 833 834 841 842 843 844 845 851 852 853 854 855

17001C01.1

6199042M3

1

Jan-06

Steering System
Direction
Dirección

4 Wheel Steer
 4 Roues Directrices
 Dirección en las 4 ruedas

C-17002-01.1-B

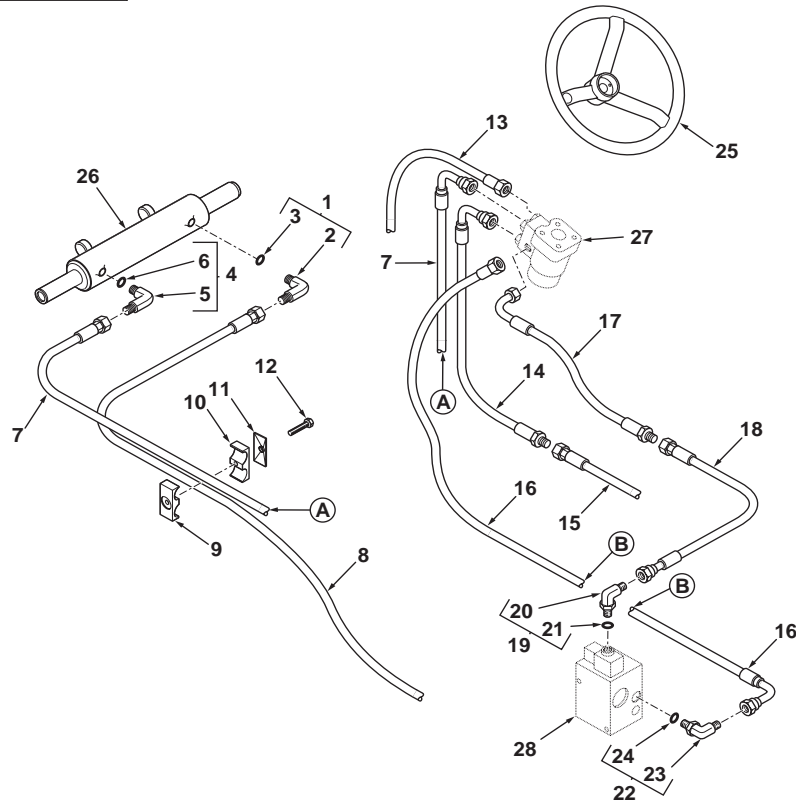

1	357197X91			1	Elbow, 90°	Coude à 90°	Codo, 90°
2		1	▶ Ref. 1	1	Elbow	Coude	Codo
3	831452M1	1		1	O-Ring	Joint torique	Junta de tipo O
4	358781X91			1	Elbow, 45°	Coude à 45°	Codo, 45°
5		4	▶ Ref. 4	1	Elbow	Coude	Codo
6		4	▶ Ref. 4	1	O-Ring	Joint torique	Junta de tipo O
7	6109571M91			1	Hose Assy	Ensemble de flexible	Flexible, Conj.
8	6109558M91		● 17002C02.1 10	1	Hose Assy	Ensemble de flexible	Flexible, Conj.
9	1470377M1			1	Bracket, Clamp	Bride de fixation	Brida de fijación
10	1470377M1			1	Bracket, Clamp	Bride de fixation	Brida de fijación
11	1470376M1			1	Plate	Plaque	Placa
12	339011X1		M8 x 45	1	Bolt	Boulon	Perno
13	6109244M91			1	Hose Assy	Ensemble de flexible	Flexible, Conj.
14	6110271M91			1	Hose Assy	Ensemble de flexible	Flexible, Conj.
15	6110272M91		● 17002C02.1 6	1	Hose Assy	Ensemble de flexible	Flexible, Conj.
16	6109245M91			1	Hose Assy	Ensemble de flexible	Flexible, Conj.
17	6109248M91			1	Hose Assy	Ensemble de flexible	Flexible, Conj.
18	6107914M91			1	Hose Assy	Ensemble de flexible	Flexible, Conj.
19	358760X91			1	Elbow, 90°	Coude à 90°	Codo, 90°
20		20	▶ Ref. 20	1	Elbow	Coude	Codo
21	831495M1	20		1	O-Ring	Joint torique	Junta de tipo O
22	835007M91			1	Elbow, 90°	Coude à 90°	Codo, 90°
23		23	▶ Ref. 23	1	Elbow	Coude	Codo
24	835024M1	23		1	O-Ring	Joint torique	Junta de tipo O
25	6106008M1			1	Wheel, Steering	Volant de direction	Volante de dirección
26			● 16014C05.1 28	1	Cylinder Assy	Ensemble de vérin	Gato, Conj.
27			● 41010C03.1 18	1	Pump, Steering	Pompe, direction	Bomba, Dirección
28			● Main Hydraulics	1	Valve Assy	Ensemble de soupape	Válvula, Conj.



970 980
 TX970B

921 922 923 931 932

17002C01.1

6199042M3

1

Jan-06

Steering System
Direction
Dirección

4 Wheel Steer
4 Roues Directrices
Dirección en las 4 ruedas

C-17002-02.1-B

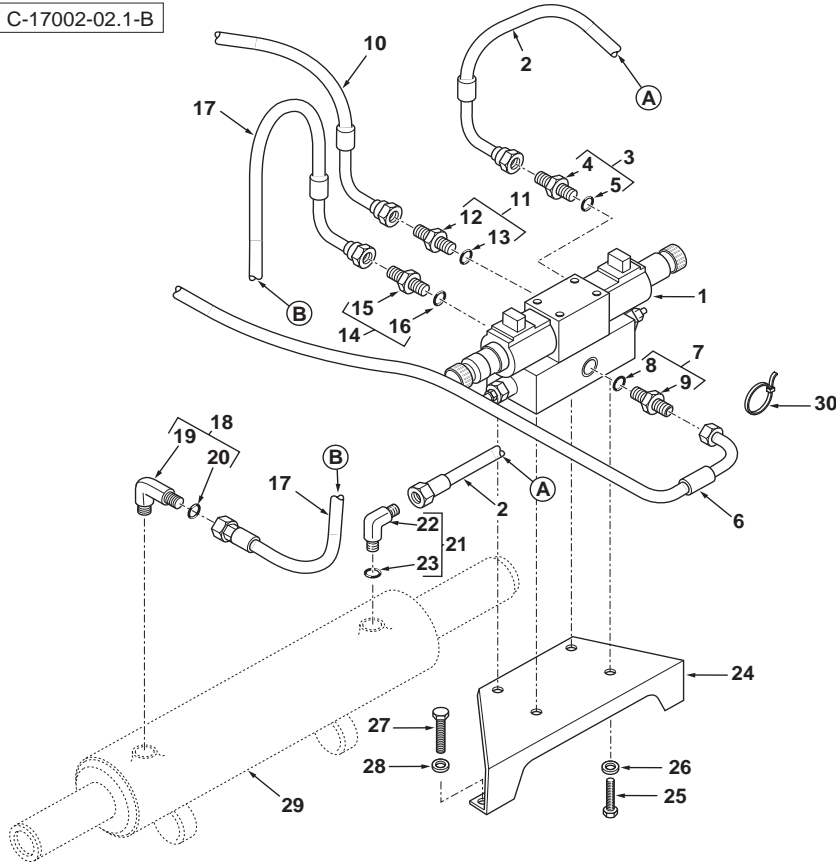

1	6109554M92		1	Valve Assy	Ensemble de soupape	Válvula, Conj.
2	6108215M91		1	Hose Assy	Ensemble de flexible	Flexible, Conj.
3	835091M91	9/16	1	Union	Union	Unión
4		3	1	Connector	Connecteur	Conector
5	831452M1	3	1	O-Ring	Joint torique	Junta de tipo O
6	6110272M91	17002C01.1 15	1	Hose Assy	Ensemble de flexible	Flexible, Conj.
7	835091M91	9/16	1	Union	Union	Unión
8		7	1	Connector	Connecteur	Conector
9	831452M1	7	1	O-Ring	Joint torique	Junta de tipo O
10	6109558M91	17002C01.1 8	1	Hose Assy	Ensemble de flexible	Flexible, Conj.
11	835091M91	9/16	1	Union	Union	Unión
12		11	1	Connector	Connecteur	Conector
13	831452M1	11	1	O-Ring	Joint torique	Junta de tipo O
14	835091M91	9/16	1	Union	Union	Unión
15		14	1	Connector	Connecteur	Conector
16	831452M1	14	1	O-Ring	Joint torique	Junta de tipo O
17	6108215M91		1	Hose Assy	Ensemble de flexible	Flexible, Conj.
18	357197X91		1	Elbow, 90°	Coude à 90°	Codo, 90°
19		18	1	Elbow	Coude	Codo
20	831452M1	18	1	O-Ring	Joint torique	Junta de tipo O
21	357197X91		1	Elbow, 90°	Coude à 90°	Codo, 90°
22		21	1	Elbow	Coude	Codo
23	831452M1	21	1	O-Ring	Joint torique	Junta de tipo O
24	6109557M3		1	Bracket	Patte de fixation	Pata de fijación
25	339123X1	M8 x 20	2	Bolt	Boulon	Perno
26	390972X1	M8	2	Washer	Rondelle	Arandela
27	339123X1	M8 x 20	2	Bolt	Boulon	Perno
28	390972X1	M8	2	Washer	Rondelle	Arandela
29		37003C04.1 28	1	Cylinder Assy	Ensemble de vérin	Gato, Conj.
30	1862425M1		1	Tie, Cable	Attache câble	Enlace de Cable



970 980
TX970B

921 922 923 931 932

17002C02.1

6199042M3

1

Jan-06

M - Wheels And Tyres • Roues et pneus • Ruedas y neumáticos

Front Wheels	18001C01.1	Roues Avants	Ruedas delanteras
Front Wheels	18004C01.1	Roues Avants	Ruedas delanteras
Front Wheels	18005C01.1	Roues Avants	Ruedas delanteras
Front Wheels	18008C01.1	Roues Avants	Ruedas delanteras
Front Wheels	18014C01.1	Roues Avants	Ruedas delanteras
Front Wheels	18015C01.1	Roues Avants	Ruedas delanteras
Front Wheels	18016C01.1	Roues Avants	Ruedas delanteras
Front Wheels	18017C01.1	Roues Avants	Ruedas delanteras
Rear Wheels	19001C01.1	Roues Arrières	Ruedas traseras
Rear Wheels	19002C01.1	Roues Arrières	Ruedas traseras
Rear Wheels	19003C01.1	Roues Arrières	Ruedas traseras
Rear Wheels	19006C01.1	Roues Arrières	Ruedas traseras
Rear Wheels	19008C01.1	Roues Arrières	Ruedas traseras
Rear Wheels	19009C01.1	Roues Arrières	Ruedas traseras
Rear Wheels	19013C01.1	Roues Arrières	Ruedas traseras
Rear Wheels	19014C01.1	Roues Arrières	Ruedas traseras
Rear Wheels	19015C01.1	Roues Arrières	Ruedas traseras
Rear Wheels	19016C01.1	Roues Arrières	Ruedas traseras
Rear Wheels	19017C01.1	Roues Arrières	Ruedas traseras



**Front Wheels
Roues Avants
Ruedas delanteras**

C-18001-01.1-A

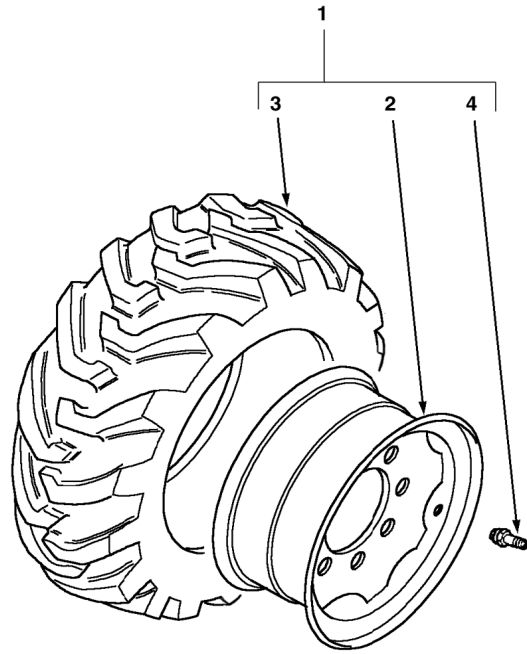

1	6109596M91Y02	(A)	2	Wheel Assy	Ensemble de roue	Rueda, Conj.
2	6109593M91Y02	1 W8L x 16	1	Wheel	Roue	Rueda
3	3511097M1	1 11L x 16 12 PLY F3	1	Tyre	Pneumatique	Neumático
4	842537M1	1	1	Valve Stem	Valve de gonflage	Válvula de inflado
1	6109596M91W01	(A)	2	Wheel Assy	Ensemble de roue	Rueda, Conj.
2	6109593M91W01	1 W8L x 16	1	Wheel	Roue	Rueda
3	3511097M1	1 11L x 16 12 PLY F3	1	Tyre	Pneumatique	Neumático
4	842537M1	1	1	Valve Stem	Valve de gonflage	Válvula de inflado

A Not serviced - order details
Non fourni - commander détails
No suministradas - pedir detalles



820
TX760B TX860B
TX870B

801 802 805 806 809 810 811 812

Front Wheels
Roues Avants
Ruedas delanteras

C-18004-01.1-A

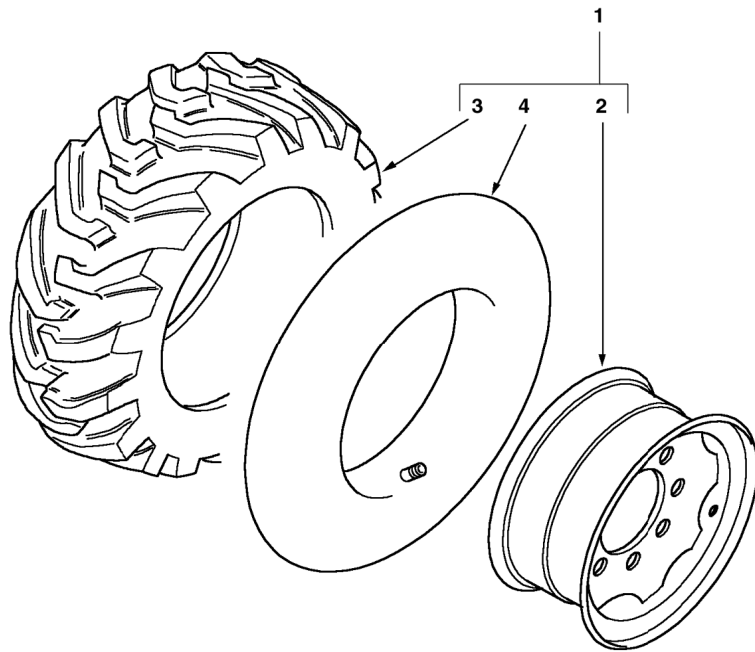

1	6109597M91Y02	(A)	2	Wheel Assy	Ensemble de roue	Rueda, Conj.
2	6109593M91Y02	1 W8L x 16	1	Wheel	Roue	Rueda
3	3511080M1	1 9.00 x 16 10 PLY F2	1	Tyre	Pneumatique	Neumático
4	880481M1	1	1	Tube, Air	Chambre à air	Cámara de aire
1	6109597M91W01	(A)	2	Wheel Assy	Ensemble de roue	Rueda, Conj.
2	6109593M91W01	1 W8L x 16	1	Wheel	Roue	Rueda
3	3511080M1	1 9.00 x 16 10 PLY F2	1	Tyre	Pneumatique	Neumático
4	880481M1	1	1	Tube, Air	Chambre à air	Cámara de aire

A Not serviced - order details
 Non fourni - commander détails
 No suministradas - pedir detalles



820
 TX760B

801 802 805 806

18004C01.1

6199042M3

1

Jan-06

Front Wheels
Roues Avants
Ruedas delanteras

C-18005-01.1-A

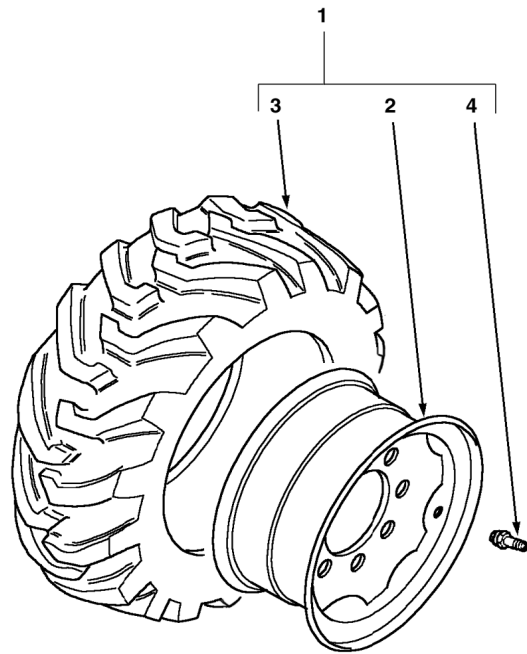

1	6109599M91Y02	(A)	1	Wheel Assy	Ensemble de roue	Rueda, Conj.
1	6109598M91Y02	(A)	1	Wheel Assy	Ensemble de roue	Rueda, Conj.
2	6109594M91Y02	1 9 x 18	1	Wheel	Roue	Rueda
3	1473951M2	1 10.5/80 x 18 10P	1	Tyre	Pneumatique	Neumático
4	842537M1	1	1	Valve Stem	Valve de gonflage	Válvula de inflado
1	6109599M91W01	(A)	1	Wheel Assy	Ensemble de roue	Rueda, Conj.
1	6109598M91W01	(A)	1	Wheel Assy	Ensemble de roue	Rueda, Conj.
2	6109594M91W01	1 9 x 18	1	Wheel	Roue	Rueda
3	1473951M2	1 10.5/80 x 18 10P	1	Tyre	Pneumatique	Neumático
4	842537M1	1	1	Valve Stem	Valve de gonflage	Válvula de inflado

A Not serviced - order details
 Non fourni - commander détails
 No suministradas - pedir detalles



820
TX760B

801 802 805 806

Front Wheels
Roues Avants
Ruedas delanteras

C-18008-01.1-A

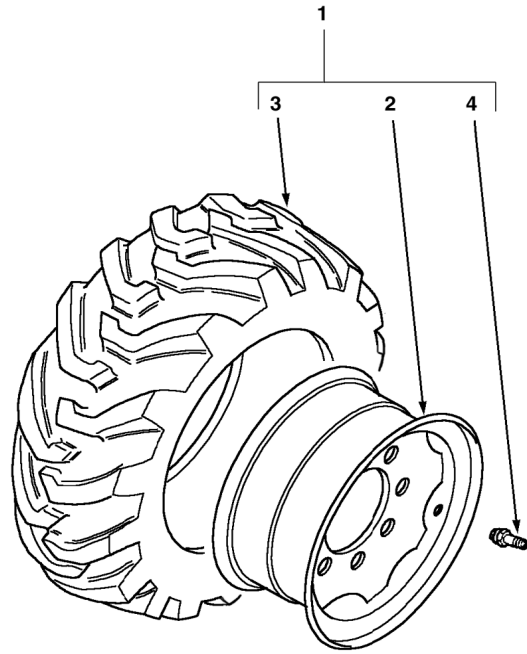

1	6109029M91Y02	(A)	1	Wheel Assy	Ensemble de roue	Rueda, Conj.
1	6109028M91Y02	(A)	1	Wheel Assy	Ensemble de roue	Rueda, Conj.
2	6109030M91Y02	1	11 x 18	Wheel	Roue	Rueda
3	3504261M2	1	12.5 x 18 10P	Tyre	Pneumatique	Neumático
4	842537M1	1		Valve Stem	Valve de gonflage	Válvula de inflado
1	6109029M91W01	(A)	1	Wheel Assy	Ensemble de roue	Rueda, Conj.
1	6109028M91W01	(A)	1	Wheel Assy	Ensemble de roue	Rueda, Conj.
2	6109030M91W01	1	11 x 18	Wheel	Roue	Rueda
3	3504261M2	1	12.5 x 18 10P	Tyre	Pneumatique	Neumático
4	842537M1	1		Valve Stem	Valve de gonflage	Válvula de inflado

A Not serviced - order details
 Non fourni - commander détails
 No suministradas - pedir detalles



820
 TX760B

807 808 833 834

Front Wheels
Roues Avants
Ruedas delanteras

C-18014-01.1-A

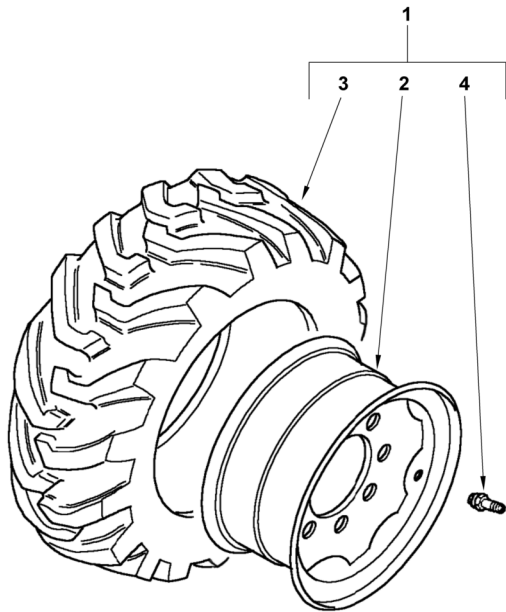

1	6110737M91Y02	(A) ◀ Mitas - 16/70x20 14P TR-09 Ind	1	Wheel Assy	Ensemble de roue	Rueda, Conj.
1	6110738M91Y02	(A) ▶ Mitas - 16/70x20 14P TR-09 Ind	1	Wheel Assy	Ensemble de roue	Rueda, Conj.
2	6109027M91	13 X 20	1	Wheel	Roue	Rueda
3	6110755M1	Mitas 16/70x20 14P TR-09 Ind	1	Tyre	Pneumatique	Neumático
4	842537M1		1	Valve Stem	Valve de gonflage	Válvula de inflado
1	6110737M91W01	(A) ◀ Mitas 16/70x20 14P TR-09 Ind	1	Wheel Assy	Ensemble de roue	Rueda, Conj.
1	6110738M91W01	(A) ▶ Mitas - 16/70x20 14P TR-09 Ind	1	Wheel Assy	Ensemble de roue	Rueda, Conj.
2	6109027M91	13 X 20	1	Wheel	Roue	Rueda
3	6110755M1	Mitas 16/70x20 14P TR-09 Ind	1	Tyre	Pneumatique	Neumático
4	842537M1		1	Valve Stem	Valve de gonflage	Válvula de inflado

A Not serviced - order details
 Non fourni - commander détails
 No suministradas - pedir detalles



860 880
 TX860B TX870B

813 814 815 816 817 821 822 823 824 825 841 842 843 844 845 851 852 853 855

Front Wheels
Roues Avants
Ruedas delanteras

C-18015-01.1-A

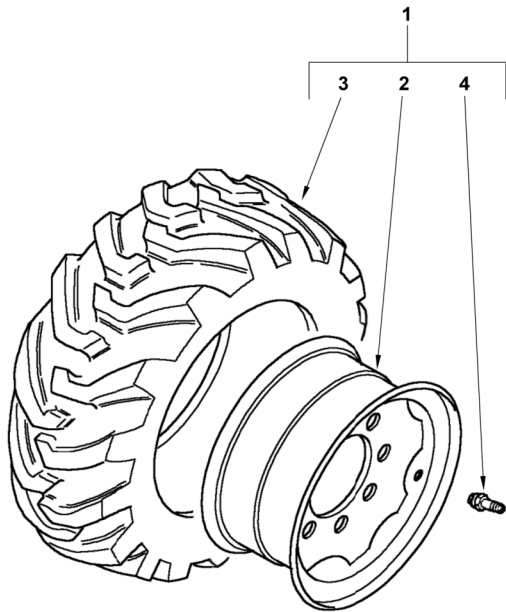

1	6110739M91Y 02	(A) ◀	1	Wheel Assy	Ensemble de roue	Rueda, Conj.
1	6110740M91Y 02	(A) ▶	1	Wheel Assy	Ensemble de roue	Rueda, Conj.
2	6109030M91		1	Wheel	Roue	Rueda
3	6110756M1		1	Tyre	Pneumatique	Neumático
4	842537M1		1	Valve Stem	Valve de gonflage	Válvula de inflado
1	6110739M91 W01	(A) ◀	1	Wheel Assy	Ensemble de roue	Rueda, Conj.
1	6110740M91 W01	(A) ▶	1	Wheel Assy	Ensemble de roue	Rueda, Conj.
2	6109030M91		1	Wheel	Roue	Rueda
3	6110756M1		1	Tyre	Pneumatique	Neumático
4	842537M1		1	Valve Stem	Valve de gonflage	Válvula de inflado

A Not serviced - order details
 Non fourni - commander détails
 No suministradas - pedir detalles



820 860 880
 TX760B TX860B
 TX870B

803 804 813 814 815 816 821 822 823 824 831 832 844 845 851 852 853 854

Front Wheels
Roues Avants
Ruedas delanteras

C-18016-01.1-A

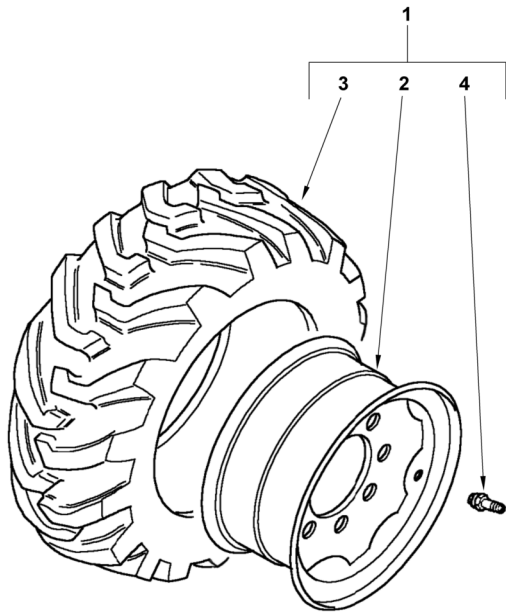

1	6110741M91Y02	(A) ◀ Mitas 405/70x20 14P MPT01 Ag	1	Wheel Assy	Ensemble de roue	Rueda, Conj.
1	6110742M91Y02	(A) ▶ Mitas 405/70x20 14P MPT01 Ag	1	Wheel Assy	Ensemble de roue	Rueda, Conj.
2	6109027M91	13 X 20	1	Wheel	Roue	Rueda
3	6110757M1	Mitas 405/70x20 14P MPT01 Ag	1	Wheel Assy	Ensemble de roue	Rueda, Conj.
4	842537M1		1	Valve Stem	Valve de gonflage	Válvula de inflado
1	6110741M91W01	(A) ◀ Mitas 405/70x20 14P MPT01 Ag	1	Wheel Assy	Ensemble de roue	Rueda, Conj.
1	6110742M91W01	(A) ▶ Mitas 405/70x20 14P MPT01 Ag	1	Wheel Assy	Ensemble de roue	Rueda, Conj.
2	6109027M91	13 X 20	1	Wheel	Roue	Rueda
3	6110757M1	Mitas 405/70x20 14P MPT01 Ag	1	Wheel Assy	Ensemble de roue	Rueda, Conj.
4	842537M1		1	Valve Stem	Valve de gonflage	Válvula de inflado

A Not serviced - order details
 Non fourni - commander détails
 No suministradas - pedir detalles



860 880
 TX860B TX870B

813 814 815 816 817 821 822 823 824 825 841 842 843 844 845 851 852 853 854
 855

Front Wheels
Roues Avants
Ruedas delanteras

C-18017-01.1-A

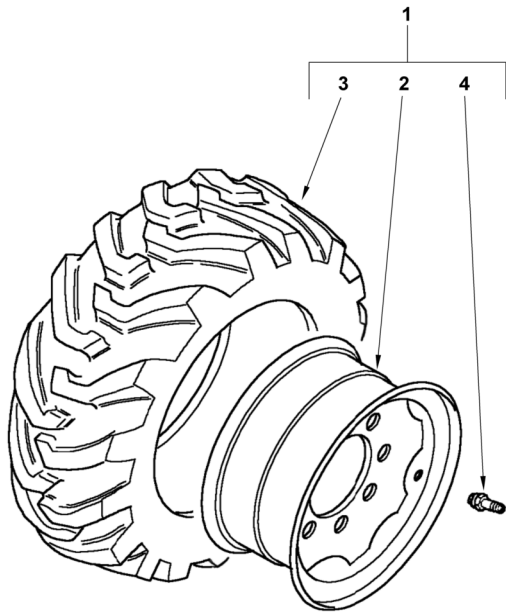

1	6110881M91Y02	(A) ◀	1	Wheel Assy	Ensemble de roue	Rueda, Conj.
1	6110882M91Y02	(A) ▶	1	Wheel Assy	Ensemble de roue	Rueda, Conj.
2	6109030M91		1	Wheel	Roue	Rueda
3	6110878M1	12.5/80 x 18 10P	1	Tyre	Pneumatique	Neumático
4	842537M1		1	Valve Stem	Valve de gonflage	Válvula de inflado
1	6110881M91W01	(A) ◀	1	Wheel Assy	Ensemble de roue	Rueda, Conj.
1	6110882M91W01	(A) ▶	1	Wheel Assy	Ensemble de roue	Rueda, Conj.
2	6109030M91		1	Wheel	Roue	Rueda
3	6110878M1	12.5/80 x 18 10P	1	Tyre	Pneumatique	Neumático
4	842537M1		1	Valve Stem	Valve de gonflage	Válvula de inflado

A Not serviced - order details
 Non fourni - commander détails
 No suministradas - pedir detalles



820
 TX760B

807 808 833 834

Rear Wheels
Roues Arrières
Ruedas traseras

C-19001-01.1-A

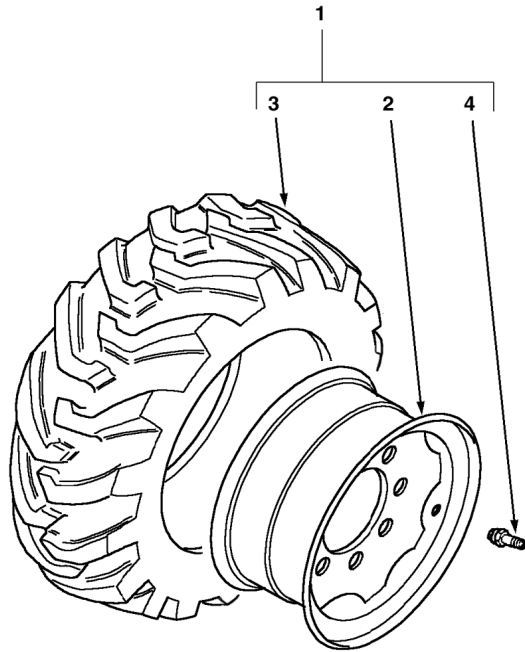

1	6103242M92Y02	(A)	1	Wheel Assy	Ensemble de roue	Rueda, Conj.
1	6103241M92Y02	(A)	1	Wheel Assy	Ensemble de roue	Rueda, Conj.
2	6103189M91	1 W15L	1	Rim, Wheel	Jante	Llanta
3	6109837M1	1 16.9 x 28 12P	1	Tyre	Pneumatique	Neumático
4	842537M1	1	1	Valve Stem	Valve de gonflage	Válvula de inflado
1	6103242M92W01	(A)	1	Wheel Assy	Ensemble de roue	Rueda, Conj.
1	6103241M92W01	(A)	1	Wheel Assy	Ensemble de roue	Rueda, Conj.
2	6103189M91	1 W15L	1	Rim, Wheel	Jante	Llanta
3	6109837M1	1 16.9 x 28 12P	1	Tyre	Pneumatique	Neumático
4	842537M1	1	1	Valve Stem	Valve de gonflage	Válvula de inflado

A Not serviced - order details
 Non fourni - commander détails
 No suministradas - pedir detalles



820
 TX760B

801 802 805 806

Rear Wheels
Roues Arrières
Ruedas traseras

C-19002-01.1-A

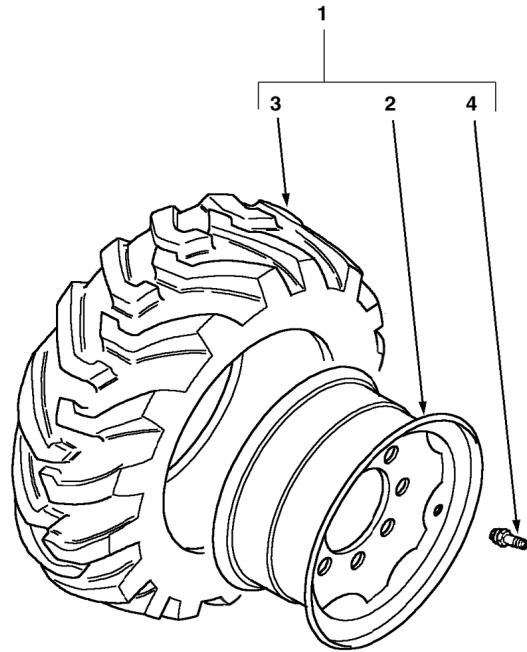

1	6103250M92Y02	(A)	1	Wheel Assy	Ensemble de roue	Rueda, Conj.
1	6103249M92Y02	(A)	1	Wheel Assy	Ensemble de roue	Rueda, Conj.
2	6103191M91	1 DW15L	1	Rim, Wheel	Jante	Llanta
3	6109839M1	1 16.9 x 30 10P	1	Tyre	Pneumatique	Neumático
4	842537M1	1	1	Valve Stem	Valve de gonflage	Válvula de inflado
1	6103250M92W01	(A)	1	Wheel Assy	Ensemble de roue	Rueda, Conj.
1	6103249M92W01	(A)	1	Wheel Assy	Ensemble de roue	Rueda, Conj.
2	6103191M91	1 DW15L	1	Rim, Wheel	Jante	Llanta
3	6109839M1	1 16.9 x 30 10P	1	Tyre	Pneumatique	Neumático
4	842537M1	1	1	Valve Stem	Valve de gonflage	Válvula de inflado

A Not serviced - order details
 Non fourni - commander détails
 No suministradas - pedir detalles



820
 TX760B

801 802 805 806

Rear Wheels
Roues Arrières
Ruedas traseras

C-19003-01.1-A

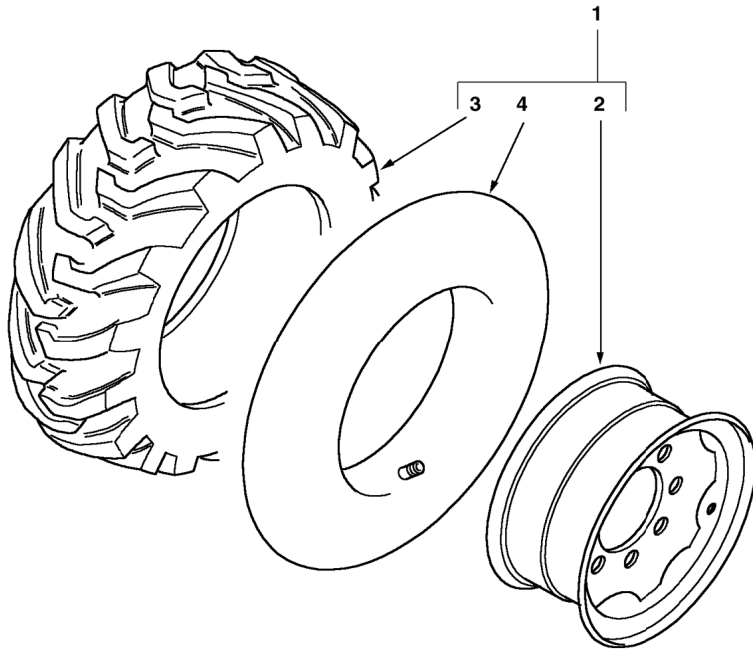

1	6103245M92 W01	(A) ▲	1	Wheel Assy	Ensemble de roue	Rueda, Conj.
1	6103246M92 W01	(A) ▶	1	Wheel Assy	Ensemble de roue	Rueda, Conj.
2	6103187M91	DW16L	1	Rim, Wheel	Jante	Llanta
3	6109736M1	18.4 x 26 R1	1	Tyre	Pneumatique	Neumático
4	1474020M1		1	Tube, Air	Chambre à air	Cámara de aire
1	6103245M92Y 02	(A) ▲	1	Wheel Assy	Ensemble de roue	Rueda, Conj.
1	6103246M92Y 02	(A) ▶	1	Wheel Assy	Ensemble de roue	Rueda, Conj.
2	6103187M91Y 02	DW16L X 26	1	Wheel	Roue	Rueda
3	6109736M1	18.4 x 26 R1	1	Tyre	Pneumatique	Neumático
4	1474020M1		1	Tube, Air	Chambre à air	Cámara de aire

A Not serviced - order details
 Non fourni - commander détails
 No suministradas - pedir detalles



820
TX760B

801 802 805 806

Rear Wheels
Roues Arrières
Ruedas traseras

C-19006-01.1-A

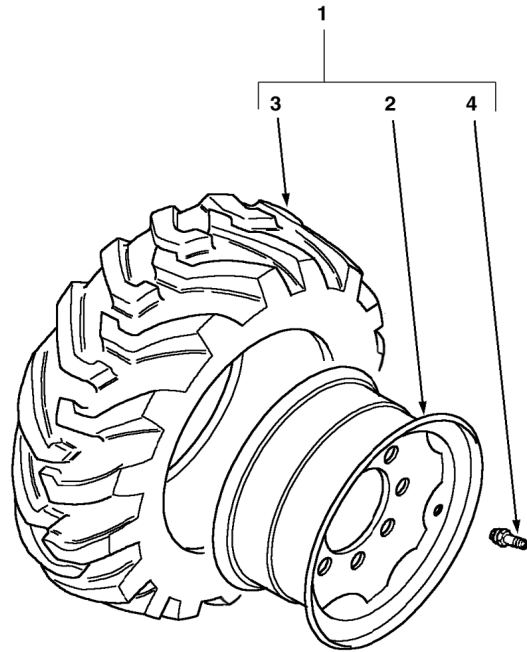

1	6109464M91Y02	(A)	1	Wheel Assy	Ensemble de roue	Rueda, Conj.
1	6109463M91Y02	(A)	1	Wheel Assy	Ensemble de roue	Rueda, Conj.
2	6103185M91	1 W15L	1	Rim, Wheel	Jante	Llanta
3	6109465M1	1 19.5L x 24 12PLY R4	1	Tyre	Pneumatique	Neumático
4	842537M1	1	1	Valve Stem	Valve de gonflage	Válvula de inflado
1	6109464M91W01	(A)	1	Wheel Assy	Ensemble de roue	Rueda, Conj.
1	6109463M91W01	(A)	1	Wheel Assy	Ensemble de roue	Rueda, Conj.
2	6103185M91	1 W15L	1	Rim, Wheel	Jante	Llanta
3	6109465M1	1 19.5L x 24 12PLY R4	1	Tyre	Pneumatique	Neumático
4	842537M1	1	1	Valve Stem	Valve de gonflage	Válvula de inflado

A Not serviced - order details
 Non fourni - commander détails
 No suministradas - pedir detalles



820
 TX760B TX860B
 TX870B

801 802 809 810 811 812

Rear Wheels
Roues Arrières
Ruedas traseras

C-19008-01.1-A

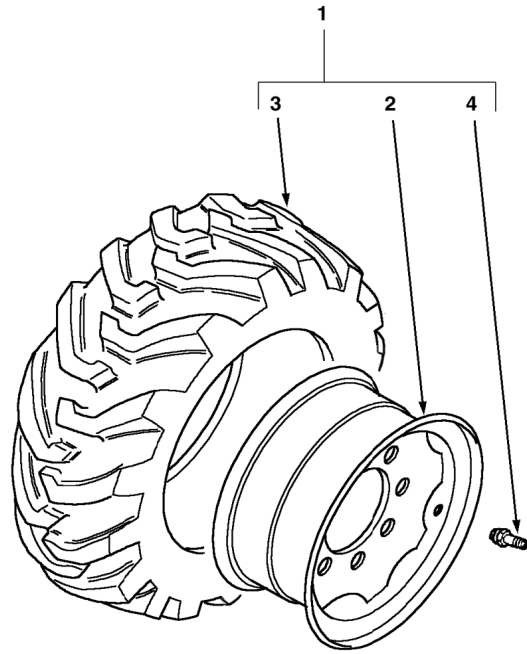

1	6108065M91Y02	(A)	2	Wheel Assy	Ensemble de roue	Rueda, Conj.
1	6108064M91Y02	(A)	2	Wheel Assy	Ensemble de roue	Rueda, Conj.
2	6103183M91Y02	1 W15L	1	Rim, Wheel	Jante	Llanta
3	6106242M1	1 16.9 R24	1	Tyre	Pneumatique	Neumático
4	842537M1	1	1	Valve Stem	Valve de gonflage	Válvula de inflado
1	6108065M91W01	(A)	2	Wheel Assy	Ensemble de roue	Rueda, Conj.
1	6108064M91W01	(A)	2	Wheel Assy	Ensemble de roue	Rueda, Conj.
2	6103183M91W01	1 W15L	1	Rim, Wheel	Jante	Llanta
3	6106242M1	1 16.9 R24	1	Tyre	Pneumatique	Neumático
4	842537M1	1	1	Valve Stem	Valve de gonflage	Válvula de inflado

A Not serviced - order details
 Non fourni - commander détails
 No suministradas - pedir detalles



970 980
 TX970B

921 922 923 931 932

Rear Wheels
Roues Arrières
Ruedas traseras

C-19009-01.1-A

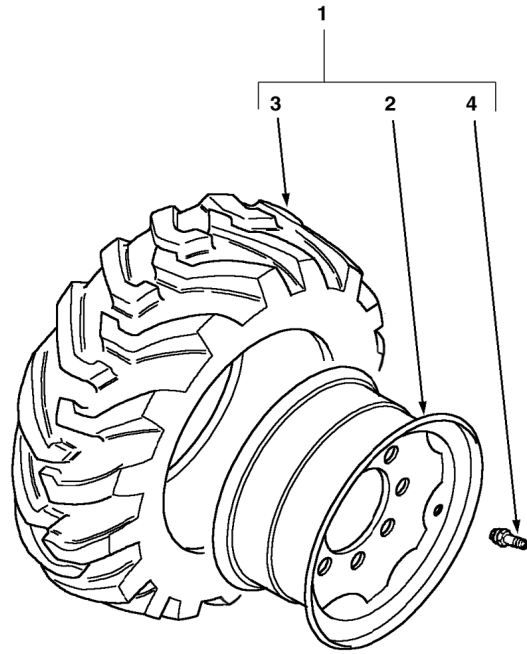

1	6108067M91Y02	(A)	2	Wheel Assy	Ensemble de roue	Rueda, Conj.
1	6108066M91Y02	(A)	2	Wheel Assy	Ensemble de roue	Rueda, Conj.
2	6103183M91Y02	1	W15L	Rim, Wheel	Jante	Llanta
3	6100225M1	1	17.5 LR24 x M27 TL146	Tyre	Pneumatique	Neumático
4	842537M1	1		Valve Stem	Valve de gonflage	Válvula de inflado
1	6108067M91W01	(A)	2	Wheel Assy	Ensemble de roue	Rueda, Conj.
1	6108066M91W01	(A)	2	Wheel Assy	Ensemble de roue	Rueda, Conj.
2	6103183M91W01	1	W15L	Rim, Wheel	Jante	Llanta
3	6100225M1	1	17.5 LR24 x M27 TL146	Tyre	Pneumatique	Neumático
4	842537M1	1		Valve Stem	Valve de gonflage	Válvula de inflado

A Not serviced - order details
 Non fourni - commander détails
 No suministradas - pedir detalles



970 980
 TX970B

921 922 923 931 932

Rear Wheels
Roues Arrières
Ruedas traseras

C-19013-01.1-A

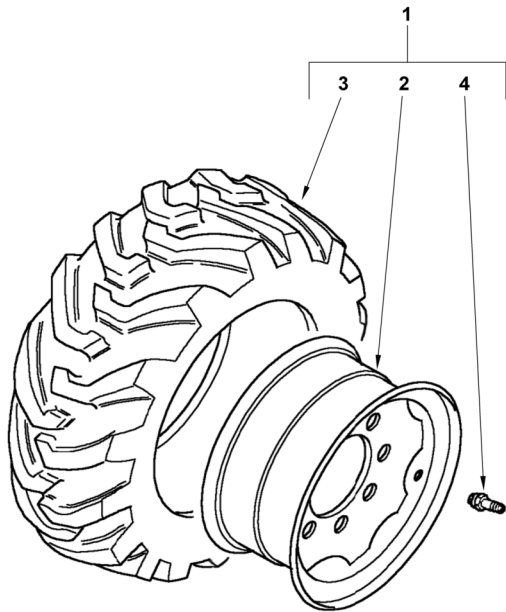

1	6110743M91Y 02	(A)	1	Wheel Assy	Ensemble de roue	Rueda, Conj.
1	6110744M91Y 02	(A)	1	Wheel Assy	Ensemble de roue	Rueda, Conj.
2	6109030M91		1	Wheel	Roue	Rueda
3	6110758M1	11 x 18	1	Tyre	Pneumatique	Neumático
4	842537M1		1	Valve Stem	Valve de gonflage	Válvula de inflado
1	6110743M91 W01	(A)	1	Wheel Assy	Ensemble de roue	Rueda, Conj.
1	6110744M91 W01	(A)	1	Wheel Assy	Ensemble de roue	Rueda, Conj.
2	6109030M91		1	Wheel	Roue	Rueda
3	6110758M1	11 x 18	1	Tyre	Pneumatique	Neumático
4	842537M1		1	Valve Stem	Valve de gonflage	Válvula de inflado

A Not serviced - order details
 Non fourni - commander détails
 No suministradas - pedir detalles



820
TX760B

807 808 833 834

Rear Wheels
Roues Arrières
Ruedas traseras

C-19014-01.1-A

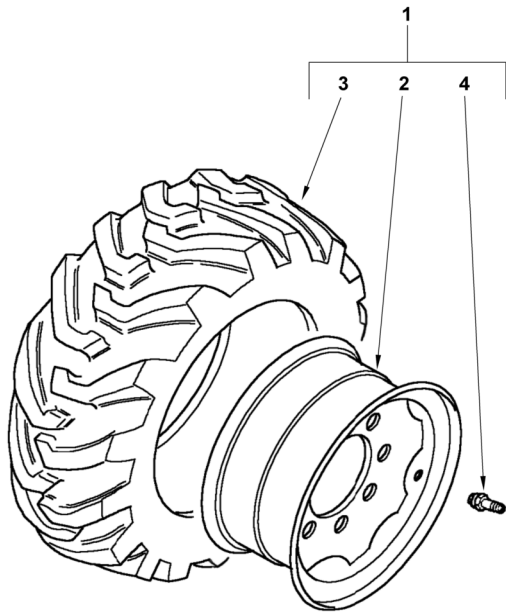

1	6110745M91Y02	(A) ◀ Mitas 16.9x24 12P I-04 Ind	1	Wheel Assy	Ensemble de roue	Rueda, Conj.
1	6110746M91Y02	(A) ▶ Mitas 19.9x24 12P TI-04 Ind	1	Wheel Assy	Ensemble de roue	Rueda, Conj.
2	6103183M91Y02	W15L	1	Rim, Wheel	Jante	Llanta
3	6110759M1	Mitas 16.9x24 12P TI-04 Ind	1	Tyre	Pneumatique	Neumático
4	842537M1		1	Valve Stem	Valve de gonflage	Válvula de inflado
1	6110745M91W01	(A) ◀ Mitas 16.9x24 12P TI-04 Ind	1	Wheel Assy	Ensemble de roue	Rueda, Conj.
1	6110746M91W01	(A) ▶ Mitas 16.9x24 123P TI-04 Ind	1	Wheel Assy	Ensemble de roue	Rueda, Conj.
2	6103183M91W01	W15L	1	Rim, Wheel	Jante	Llanta
3	6110759M1	Mitas 16.9x24 12P TI-04 Ind	1	Tyre	Pneumatique	Neumático
4	842537M1		1	Valve Stem	Valve de gonflage	Válvula de inflado

A Not serviced - order details
 Non fourni - commander détails
 No suministradas - pedir detalles



970 980
 TX970B

921 922 923 931 932

Rear Wheels
Roues Arrières
Ruedas traseras

C-19015-01.1-A

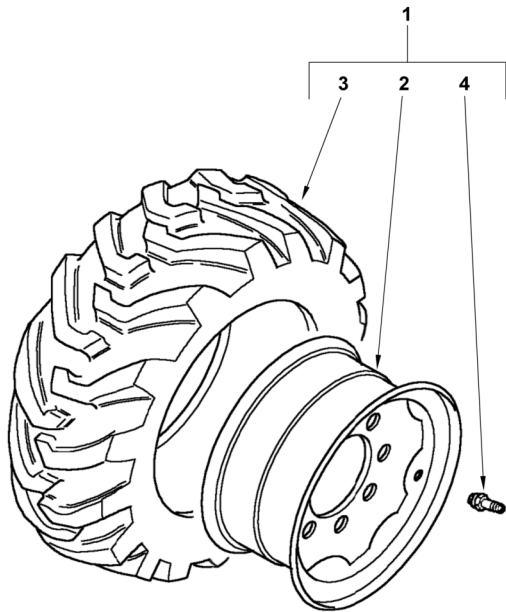

1	6110747M91Y 02	(A) ◀	1	Wheel Assy	Ensemble de roue	Rueda, Conj.
1	6110748M91Y 02	(A) ▶	1	Wheel Assy	Ensemble de roue	Rueda, Conj.
2	6103187M91	DW16L	1	Rim, Wheel	Jante	Llanta
3	6110760M1	18.4 x 26 12P	1	Tyre	Pneumatique	Neumático
4	842537M1		1	Valve Stem	Valve de gonflage	Válvula de inflado
1	6110747M91 W01	(A) ◀	1	Wheel Assy	Ensemble de roue	Rueda, Conj.
1	6110748M91 W01	(A) ▶	1	Wheel Assy	Ensemble de roue	Rueda, Conj.
2	6103187M91	DW16L	1	Rim, Wheel	Jante	Llanta
3	6110760M1	18.4 x 26 12P	1	Tyre	Pneumatique	Neumático
4	842537M1		1	Valve Stem	Valve de gonflage	Válvula de inflado

A Not serviced - order details
 Non fourni - commander détails
 No suministradas - pedir detalles



820 860 880
 TX760B TX860B
 TX870B

807 808 813 814 815 816 817 821 822 823 824 825 833 834 841 842 843 844 845
 851 852 853 854 855

Rear Wheels
Roues Arrières
Ruedas traseras

Not Illustrated

Non Illustrée

Nicht Abgebildet

Non Illustrato

No Ilustrado

1	6110749M91Y 02	(A) ◀	1	Wheel Assy	Ensemble de roue	Rueda, Conj.
1	6110750M91Y 02	(A) ▶	1	Wheel Assy	Ensemble de roue	Rueda, Conj.
2	6103191M91	DW15L	1	Rim, Wheel	Jante	Llanta
3	6110761M1	16.9 x 30 14P	1	Tyre	Pneumatique	Neumático
4	842537M1		1	Valve Stem	Valve de gonflage	Válvula de inflado
1	6110749M91 W01	(A) ◀	1	Wheel Assy	Ensemble de roue	Rueda, Conj.
1	6110750M91 W01	(A) ▶	1	Wheel Assy	Ensemble de roue	Rueda, Conj.
2	6103191M91	DW15L	1	Rim, Wheel	Jante	Llanta
3	6110761M1	16.9 x 30 14P	1	Tyre	Pneumatique	Neumático
4	842537M1		1	Valve Stem	Valve de gonflage	Válvula de inflado

A Not serviced - order details
Non fourni - commander détails
No suministradas - pedir detalles



820 860 880
TX760B TX860B
TX870B

807 808 813 814 815 816 817 821 822 823 824 825 833 834 841 842 843 844 845
851 852 853 855

Rear Wheels
Roues Arrières
Ruedas traseras

C-19017-01.1-A

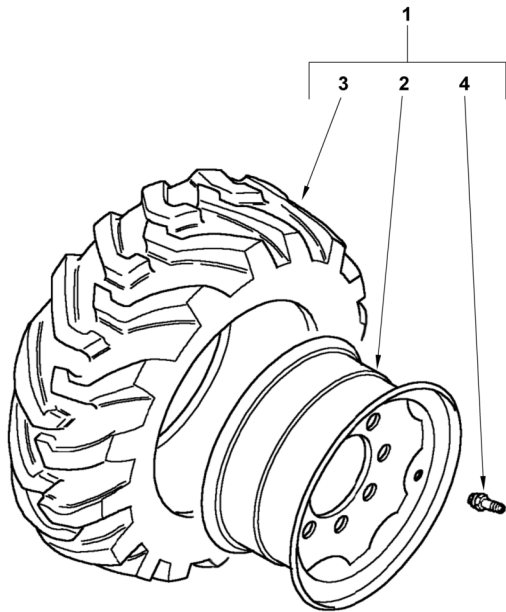

1	6110751M91 W01	(A) ▲	1	Wheel Assy	Ensemble de roue	Rueda, Conj.
1	6110752M91 W01	(A) ▼	1	Wheel Assy	Ensemble de roue	Rueda, Conj.
2	6103185M91Y 02	W15L X 24	1	Wheel	Roue	Rueda
3	6110762M1		1	Tyre	Pneumatique	Neumático
4	842537M1		1	Valve Stem	Valve de gonflage	Válvula de inflado
1	6110751M91Y 02	(A) ▲	1	Wheel Assy	Ensemble de roue	Rueda, Conj.
1	6110752M91Y 02	(A) ▼	1	Wheel Assy	Ensemble de roue	Rueda, Conj.
2	6110762M1		1	Tyre	Pneumatique	Neumático
3	6103185M91Y 02	W15L X 24	1	Wheel	Roue	Rueda
4	842537M1		1	Valve Stem	Valve de gonflage	Válvula de inflado

A Not serviced - order details
 Non fourni - commander détails
 No suministradas - pedir detalles



820 860 880
 TX760B TX860B
 TX870B

803 804 813 814 815 816 821 822 823 824 831 832 844 845 851 852 853 854

N - Drive Train and Brakes • Transmission et freins • Transmisión y frenos

Differential Lock.....	44001C01.1	Blocage de Différentiel	Bloqueo de diferencial
Differential Lock.....	44002C01.1	Blocage de Différentiel	Bloqueo de diferencial
Differential Lock.....	44003C01.1	Blocage de Différentiel	Bloqueo de diferencial
Differential Lock.....	44004C01.1	Blocage de Différentiel	Bloqueo de diferencial
Differential Lock - Controls	44001C02.1	Blocage de Différentiel - Contrôle	Bloqueo de diferencial - Control
Drive Line Bolting	28010C01.1	Boulonnage	Fijación con pernos
Drive Line Bolting	28011C01.1	Boulonnage	Fijación con pernos
Drive Line Bolting	28012C01.1	Boulonnage	Fijación con pernos
Gear Change - Control Lever	31001C01.1	Changement de Vitesses - Levier de Commande	Cambio de velocidades - Palanca de mando
Gear Change - Control Lever	31002C01.1	Changement de Vitesses - Levier de Commande	Cambio de velocidades - Palanca de mando
Gear Change - Control Lever	31006C01.1	Changement de Vitesses - Levier de Commande	Cambio de velocidades - Palanca de mando
Gear Change - Control Lever	31007C01.1	Changement de Vitesses - Levier de Commande	Cambio de velocidades - Palanca de mando
Gear Change - Transmission Control Unit.....	31003C01.1	Changement de Vitesses - Unité de Commande de Transmission	Cambio de velocidades - Unidad de control de transmisión
Gear Change - Transmission Control Unit.....	31004C01.1	Changement de Vitesses - Unité de Commande de Transmission	Cambio de velocidades - Unidad de control de transmisión
Gear Change - Transmission Control Unit.....	31005C01.1	Changement de Vitesses - Unité de Commande de Transmission	Cambio de velocidades - Unidad de control de transmisión
Parking Brake.....	45001C01.1	Frein à Main	Freno de aparcamiento
Parking Brake.....	45002C01.1	Frein à Main	Freno de aparcamiento
Rear Axle.....	37001C01.1	Essieu Arrière	Eje trasero
Rear Axle.....	37002C01.1	Essieu Arrière	Eje trasero
Rear Axle.....	37003C01.1	Essieu Arrière	Eje trasero
Rear Axle.....	37004C01.1	Essieu Arrière	Eje trasero
Rear Axle.....	37004C02.1	Essieu Arrière	Eje trasero
Rear Axle.....	37004C03.1	Essieu Arrière	Eje trasero
Rear Axle.....	37004C04.1	Essieu Arrière	Eje trasero
Rear Axle.....	37004C05.1	Essieu Arrière	Eje trasero
Rear Axle.....	37004C06.1	Essieu Arrière	Eje trasero
Rear Axle.....	37004C07.1	Essieu Arrière	Eje trasero
Rear Axle.....	37004C08.1	Essieu Arrière	Eje trasero
Rear Axle.....	37004C09.1	Essieu Arrière	Eje trasero
Rear Axle - Brake Caliper.....	37001C07.1	Essieu Arrière - Mâchoire de Frein	Eje trasero - Calibrador de freno
Rear Axle - Brake Caliper.....	37001C08.1	Essieu Arrière - Mâchoire de Frein	Eje trasero - Calibrador de freno
Rear Axle - Brake Caliper.....	37002C07.1	Essieu Arrière - Mâchoire de Frein	Eje trasero - Calibrador de freno
Rear Axle - Brake Caliper.....	37002C08.1	Essieu Arrière - Mâchoire de Frein	Eje trasero - Calibrador de freno
Rear Axle - Brake Caliper.....	37003C08.1	Essieu Arrière - Mâchoire de Frein	Eje trasero - Calibrador de freno
Rear Axle - Brake Caliper.....	37003C09.1	Essieu Arrière - Mâchoire de Frein	Eje trasero - Calibrador de freno
Rear Axle - Brakes	37001C06.1	Essieu Arrière - Freins - Freins	Eje trasero - Frenos - Frenos
Rear Axle - Brakes	37002C06.1	Essieu Arrière - Freins - Freins	Eje trasero - Frenos - Frenos
Rear Axle - Brakes	37003C07.1	Essieu Arrière - Freins - Freins	Eje trasero - Frenos - Frenos



N - Drive Train and Brakes • Transmission et freins • Transmisión y frenos

Rear Axle - Centre Housing.....	37001C03.1	Essieu Arrière - Carter Central	Eje trasero - Cáster central
Rear Axle - Centre Housing.....	37002C03.1	Essieu Arrière - Carter Central	Eje trasero - Cáster central
Rear Axle - Centre Housing.....	37003C03.1	Essieu Arrière - Carter Central	Eje trasero - Cáster central
Rear Axle - Differential	37001C09.1	Essieu Arrière - Différentiel	Eje trasero - Diferencial
Rear Axle - Differential	37001C10.1	Essieu Arrière - Différentiel	Eje trasero - Diferencial
Rear Axle - Differential	37002C09.1	Essieu Arrière - Différentiel	Eje trasero - Diferencial
Rear Axle - Differential	37002C10.1	Essieu Arrière - Différentiel	Eje trasero - Diferencial
Rear Axle - Differential	37003C11.1	Essieu Arrière - Différentiel	Eje trasero - Diferencial
Rear Axle - Differential	37003C12.1	Essieu Arrière - Différentiel	Eje trasero - Diferencial
Rear Axle - Differential Lock Mechanism	37001C11.1	Essieu Arrière - Blocage de Différentiel	Eje trasero - Bloqueo de diferencial
Rear Axle - Differential Lock Mechanism	37002C11.1	Essieu Arrière - Blocage de Différentiel	Eje trasero - Bloqueo de diferencial
Rear Axle - Differential Lock Mechanism	37003C13.1	Essieu Arrière - Blocage de Différentiel	Eje trasero - Bloqueo de diferencial
Rear Axle - Drive Shaft.....	37003C10.1	Essieu Arrière - Arbre d'entraînement	Eje trasero - Árbol de arrastre
Rear Axle - Epicyclic Reduction Gear	37001C05.1	Essieu Arrière - Train Épicycloïdal	Eje trasero - Reductor epicíclico
Rear Axle - Epicyclic Reduction Gear	37002C05.1	Essieu Arrière - Train Épicycloïdal	Eje trasero - Reductor epicíclico
Rear Axle - Epicyclic Reduction Gear	37003C06.1	Essieu Arrière - Train Épicycloïdal	Eje trasero - Reductor epicíclico
Rear Axle - Housing	37001C02.1	Essieu Arrière - Pont Arrière - Carter	Eje trasero - Cáster
Rear Axle - Housing	37002C02.1	Essieu Arrière - Pont Arrière - Carter	Eje trasero - Cáster
Rear Axle - Housing	37003C02.1	Essieu Arrière - Pont Arrière - Carter	Eje trasero - Cáster
Rear Axle - Steering Pivot.....	37003C04.1	Essieu Arrière - Pivot de Direction	Eje trasero - Pivote de dirección
Rear Axle - Wheel Hub.....	37001C04.1	Essieu Arrière - Moyeu de Roue	Eje trasero - Cubo de rueda
Rear Axle - Wheel Hub.....	37002C04.1	Essieu Arrière - Moyeu de Roue	Eje trasero - Cubo de rueda
Rear Axle - Wheel Hub.....	37003C05.1	Essieu Arrière - Moyeu de Roue	Eje trasero - Cubo de rueda
Service Brake - Brake Circuit.....	43010C01.1	Frein de Service - Circuit de Freinage	Freno de servicio - Circuito de freno
Service Brake - Brake Circuit.....	43011C01.1	Frein de Service - Circuit de Freinage	Freno de servicio - Circuito de freno
Service Brake - Brake Circuit.....	43012C01.1	Frein de Service - Circuit de Freinage	Freno de servicio - Circuito de freno
Service Brake - Brake Circuit.....	43014C01.1	Frein de Service - Circuit de Freinage	Freno de servicio - Circuito de freno
Torque Converter.....	27002C01.1	Convertisseur	Convertidor de par
Torque Converter.....	27010C01.1	Convertisseur	Convertidor de par
Torque Converter - Hydraulic Lines.....	39001C01.1	Convertisseur - Circuit Hydraulique	Convertidor de par - Circuito hidráulico
Torque Converter - Hydraulic Lines.....	39002C01.1	Convertisseur - Circuit Hydraulique	Convertidor de par - Circuito hidráulico
Torque Converter - Hydraulic Lines.....	39003C01.1	Convertisseur - Circuit Hydraulique	Convertidor de par - Circuito hidráulico
Transmission - 4 Wheel Drive Shaft.....	29002C08.1	Transmission - Arbre de Commande 4 Roues Motrices	Transmisión - Árbol de arrastre 4m
Transmission - 4 Wheel Drive Shaft.....	29005C10.1	Transmission - Arbre de Commande 4 Roues Motrices	Transmisión - Árbol de arrastre 4m
Transmission - Charging Pump.....	29003C05.1	Transmission - Pompe de Remplissage	Transmisión - Bomba de carga
Transmission - Charging Pump.....	29003C06.1	Transmission - Pompe de Remplissage	Transmisión - Bomba de carga
Transmission - Charging Pump.....	29004C05.1	Transmission - Pompe de Remplissage	Transmisión - Bomba de carga
Transmission - Charging Pump.....	29004C06.1	Transmission - Pompe de Remplissage	Transmisión - Bomba de carga



N - Drive Train and Brakes • Transmission et freins • Transmisión y frenos

Transmission - Charging Pump.....29005C04.1	Transmission - Pompe de Remplissage	Transmisión - Bomba de carga
Transmission - Control Valve.....29003C13.1	Transmission - Distributeur	Transmisión - Distribuidor de mando
Transmission - Control Valve.....29004C13.1	Transmission - Distributeur	Transmisión - Distribuidor de mando
Transmission - Control Valve.....29005C12.1	Transmission - Distributeur	Transmisión - Distribuidor de mando
Transmission - Control Valve Mounting.....29003C12.1	Transmission - Support de Distributeur	Transmisión - Fijación del distribuidor de mando
Transmission - Control Valve Mounting.....29004C12.1	Transmission - Support de Distributeur	Transmisión - Fijación del distribuidor de mando
Transmission - Converter Housing.....29003C03.1	Transmission - Carter de Convertisseur	Transmisión - Cáster del convertidor
Transmission - Converter Housing.....29004C03.1	Transmission - Carter de Convertisseur	Transmisión - Cáster del convertidor
Transmission - Drive Plate.....29003C14.1	Transmission - Disque d'entraînement	Transmisión - Disco accionamiento
Transmission - Drive Plate.....29004C14.1	Transmission - Disque d'entraînement	Transmisión - Disco accionamiento
Transmission - Drive Shaft.....29001C02.1	Transmission - Arbre d'entraînement	Transmisión - Árbol de arrastre
Transmission - Drive Shaft.....29002C02.1	Transmission - Arbre d'entraînement	Transmisión - Árbol de arrastre
Transmission - Drive Shaft.....29003C02.1	Transmission - Arbre d'entraînement	Transmisión - Árbol de arrastre
Transmission - Drive Shaft.....29004C02.1	Transmission - Arbre d'entraînement	Transmisión - Árbol de arrastre
Transmission - Drive Shaft.....29005C01.1	Transmission - Arbre d'entraînement	Transmisión - Árbol de arrastre
Transmission - Fork And Gearshift Rails.....29005C11.1	Transmission - Axes et Fourchettes	Transmisión - Horquillas
Transmission - Fwd Low / Fwd High Shaft.....29003C07.1	Transmission - Arbre Avant Inférieur / Arrière Supérieur	Transmisión - Árbol de marcha adelante baja/alta
Transmission - Fwd Low / Fwd High Shaft.....29004C07.1	Transmission - Arbre Avant Inférieur / Arrière Supérieur	Transmisión - Árbol de marcha adelante baja/alta
Transmission - Housing.....29001C03.1	Transmission - Carter	Transmisión - Alojamiento
Transmission - Housing.....29002C03.1	Transmission - Carter	Transmisión - Alojamiento
Transmission - Housing.....29003C04.1	Transmission - Carter	Transmisión - Alojamiento
Transmission - Housing.....29004C04.1	Transmission - Carter	Transmisión - Alojamiento
Transmission - Housing.....29005C06.1	Transmission - Carter	Transmisión - Alojamiento
Transmission - Input Shaft.....29001C04.1	Transmission - Arbre d'entrée	Transmisión - Árbol de entrada
Transmission - Input Shaft.....29002C04.1	Transmission - Arbre d'entrée	Transmisión - Árbol de entrada
Transmission - Input Shaft.....29003C09.1	Transmission - Arbre d'entrée	Transmisión - Árbol de entrada
Transmission - Input Shaft.....29004C09.1	Transmission - Arbre d'entrée	Transmisión - Árbol de entrada
Transmission - Input Shaft.....29005C07.1	Transmission - Arbre d'entrée	Transmisión - Árbol de entrada
Transmission - Main Shaft.....29001C06.1	Transmission - Arbre Principal	Transmisión - Árbol principal
Transmission - Main Shaft.....29002C06.1	Transmission - Arbre Principal	Transmisión - Árbol principal
Transmission - Oil Filler.....29001C01.1	Transmission - Bouchon de Remplissage d'huile	Transmisión - Tubo de llenado aceite
Transmission - Oil Filler.....29002C01.1	Transmission - Bouchon de Remplissage d'huile	Transmisión - Tubo de llenado aceite
Transmission - Oil Filler.....29003C01.1	Transmission - Bouchon de Remplissage d'huile	Transmisión - Tubo de llenado aceite
Transmission - Oil Filler.....29004C01.1	Transmission - Bouchon de Remplissage d'huile	Transmisión - Tubo de llenado aceite
Transmission - Oil Filler.....29005C02.1	Transmission - Bouchon de Remplissage d'huile	Transmisión - Tubo de llenado aceite
Transmission - Oil Filter.....29005C03.1	Transmission - Filtre à Huile	Transmisión - Filtro de aceite
Transmission - Oil Strainer.....29005C05.1	Transmission - Filtre à tamis	Transmisión - Colador
Transmission - Output Shaft.....29001C07.1	Transmission - Arbre de Sortie	Transmisión - Árbol de salida



N - Drive Train and Brakes • Transmission et freins • Transmisión y frenos

Transmission - Output Shaft.....29002C07.1	Transmission - Arbre de Sortie	Transmisión - Árbol de salida
Transmission - Reverse / First Shaft29003C08.1	Transmission - Marche Arrière / Arbre Principal	Transmisión - Árbol de marcha atrás/primera
Transmission - Reverse / First Shaft29004C08.1	Transmission - Marche Arrière / Arbre Principal	Transmisión - Árbol de marcha atrás/primera
Transmission - Reverse / First Shaft29005C08.1	Transmission - Marche Arrière / Arbre Principal	Transmisión - Árbol de marcha atrás/primera
Transmission - Reverse Idler Shaft29001C05.1	Transmission - Arbre de Renvoi Marche Arrière	Transmisión - Árbol de reenvío marcha atrás
Transmission - Reverse Idler Shaft29002C05.1	Transmission - Arbre de Renvoi Marche Arrière	Transmisión - Árbol de reenvío marcha atrás
Transmission - Second Shaft29003C10.1	Transmission - Arbre Secondaire	Transmisión - Árbol de segunda
Transmission - Second Shaft29003C11.1	Transmission - Arbre Secondaire	Transmisión - Árbol de segunda
Transmission - Second Shaft29004C10.1	Transmission - Arbre Secondaire	Transmisión - Árbol de segunda
Transmission - Second Shaft29004C11.1	Transmission - Arbre Secondaire	Transmisión - Árbol de segunda
Transmission - Second Shaft29005C09.1	Transmission - Arbre Secondaire	Transmisión - Árbol de segunda
Transmission - Solenoid Valve29005C13.1	Transmission - Électrovanne	Transmisión - Electroválvula



Differential Lock
 Blocage de Différentiel
 Bloqueo de diferencial

Synchro Shuttle
 Synchro Shuttle
 Synchro Shuttle

C-44001-01.1-A

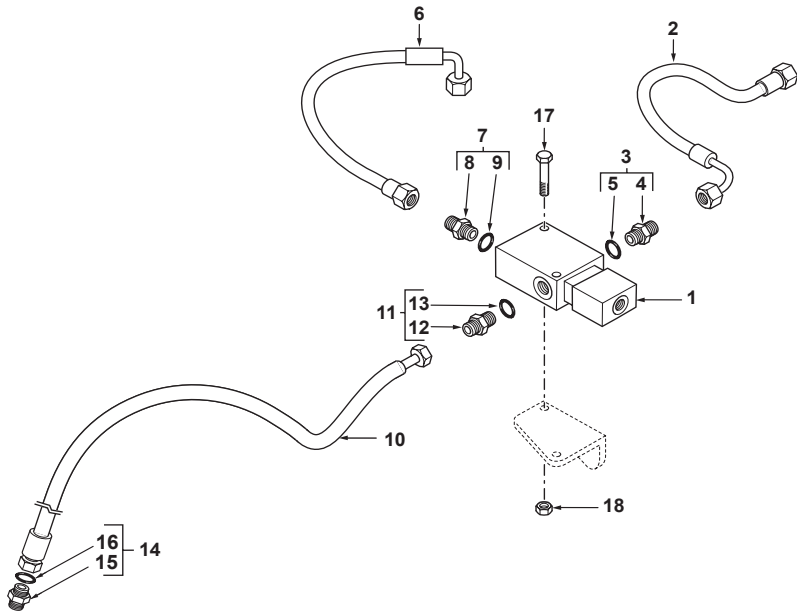

1	6098067M91	44001C02.1	1	Valve, Solenoid	Électrovalve	Electroválvula
2	6108807M91		1	Hose Assy	Ensemble de flexible	Flexible, Conj.
3	835091M91	9/16	1	Union	Union	Unión
4		3	1	Union	Union	Unión
5	831452M1	3	1	O-Ring	Joint torique	Junta de tipo O
6	6108807M91		1	Hose Assy	Ensemble de flexible	Flexible, Conj.
7	835091M91	9/16	1	Union	Union	Unión
8		7	1	Union	Union	Unión
9	831452M1	7	1	O-Ring	Joint torique	Junta de tipo O
10	6109110M91		1	Hose Assy	Ensemble de flexible	Flexible, Conj.
11	835091M91	9/16	1	Union	Union	Unión
12		11	1	Union	Union	Unión
13	831452M1	11	1	O-Ring	Joint torique	Junta de tipo O
14	835091M91	9/16	1	Union	Union	Unión
15		14	1	Union	Union	Unión
16	831452M1	14	1	O-Ring	Joint torique	Junta de tipo O
17	391244X1	M6 x 45	2	Bolt	Boulon	Perno
18	1441500X1	M6	2	Nut, Lock	Écrou de blocage	Tuerca de retención



820 860 880
 TX760B TX860B
 TX870B

801 802 803 804 805 806 807 808 809 810 811 812 813 814 815 816 817 831 832
 833 834 841 842 843 844 845

44001C01.1

6199042M3



1

Jan-06

Differential Lock
Blocage de Différentiel
Bloqueo de diferencial

Powershift
 Powershift
 Powershift

C-44002-01.1-A

1	6109473M91			1	Hose Assy	Ensemble de flexible	Flexible, Conj.
2	835091M91	9/16		1	Union	Union	Unión
3		2	 Ref. 2	1	Union	Union	Unión
4	831452M1	2		1	O-Ring	Joint torique	Junta de tipo O
5	835091M91	9/16		1	Union	Union	Unión
6		5	 Ref. 5	1	Union	Union	Unión
7	831452M1	5		1	O-Ring	Joint torique	Junta de tipo O

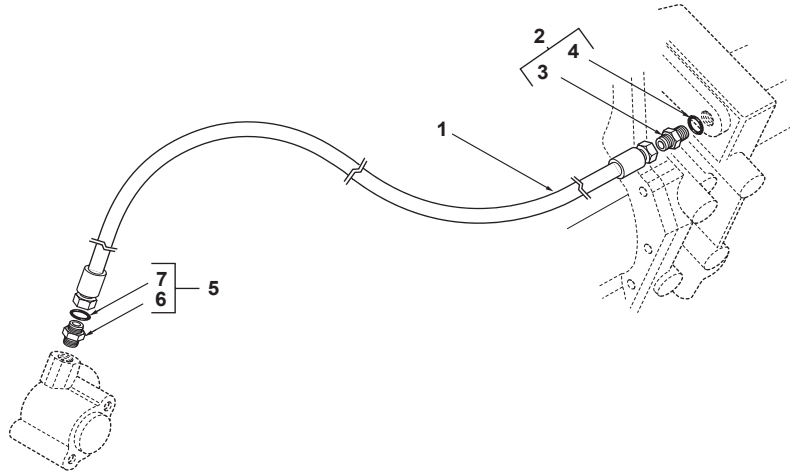



970 980
 TX970B

921 922 923 931 932

Differential Lock
 Blocage de Différentiel
 Bloqueo de diferencial

Powershift
 Powershift
 Powershift

C-44003-01.1-A

1	6106574M91			1	Hose Assy	Ensemble de flexible	Flexible, Conj.
2	835091M91	9/16		1	Union	Union	Unión
3		2	 Ref. 2	1	Union	Union	Unión
4	831452M1	2		1	O-Ring	Joint torique	Junta de tipo O
5	358781X91			1	Elbow, 45°	Coude à 45°	Codo, 45°
6		5	 Ref. 5	1	Elbow	Coude	Codo
7	831452M1	5		1	O-Ring	Joint torique	Junta de tipo O

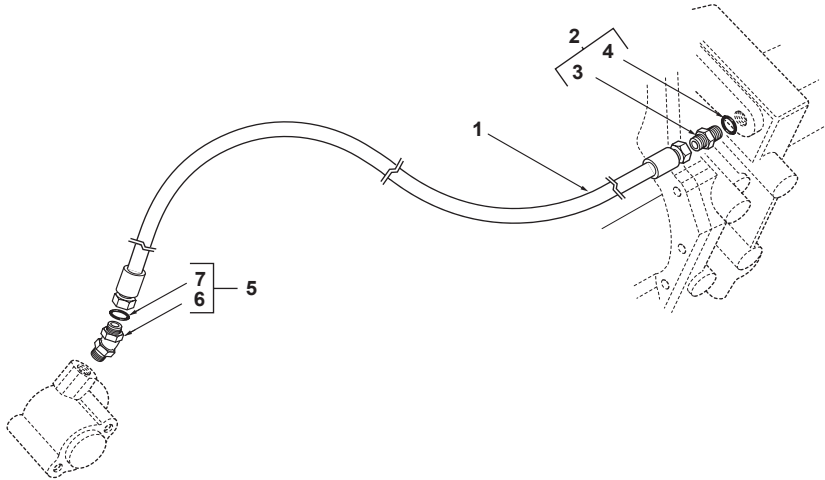

860 880
 TX860B TX870B

821 822 823 824 825 851 852 853 854 855

44003C01.1

6199042M3

1

Jan-06

Differential Lock
 Blocage de Différentiel
 Bloqueo de diferencial

Synchro Shuttle
 Synchro Shuttle
 Synchro Shuttle

C-44004-01.1-A

1	6109246M91			1	Hose Assy	Ensemble de flexible	Flexible, Conj.
2	835091M91	9/16		1	Union	Union	Unión
3		2	▶ Ref. 2	1	Union	Union	Unión
4	831452M1	2		1	O-Ring	Joint torique	Junta de tipo O
5	357197X91			1	Elbow, 90°	Coude à 90°	Codo, 90°
6		5	▶ Ref. 5	1	Elbow	Coude	Codo
7	831452M1	5		1	O-Ring	Joint torique	Junta de tipo O

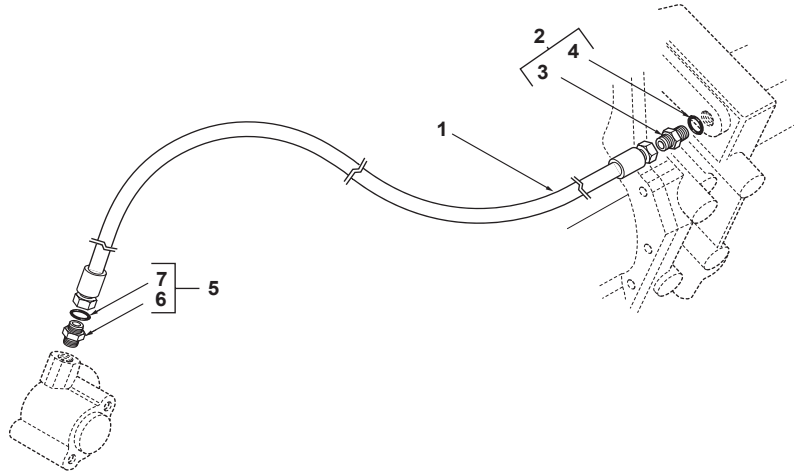

820 860 880
 TX760B TX860B
 TX870B

803 804 807 808 813 814 815 816 817 841 842 843 844 845

44004C01.1

6199042M3

1

Jan-06

Differential Lock
Blocage de Différentiel
Bloqueo de diferencial

Controls
Contrôle
Control

Solenoid Valve
 Electrovanne
 Electroválvula

C-44001-02.1-A

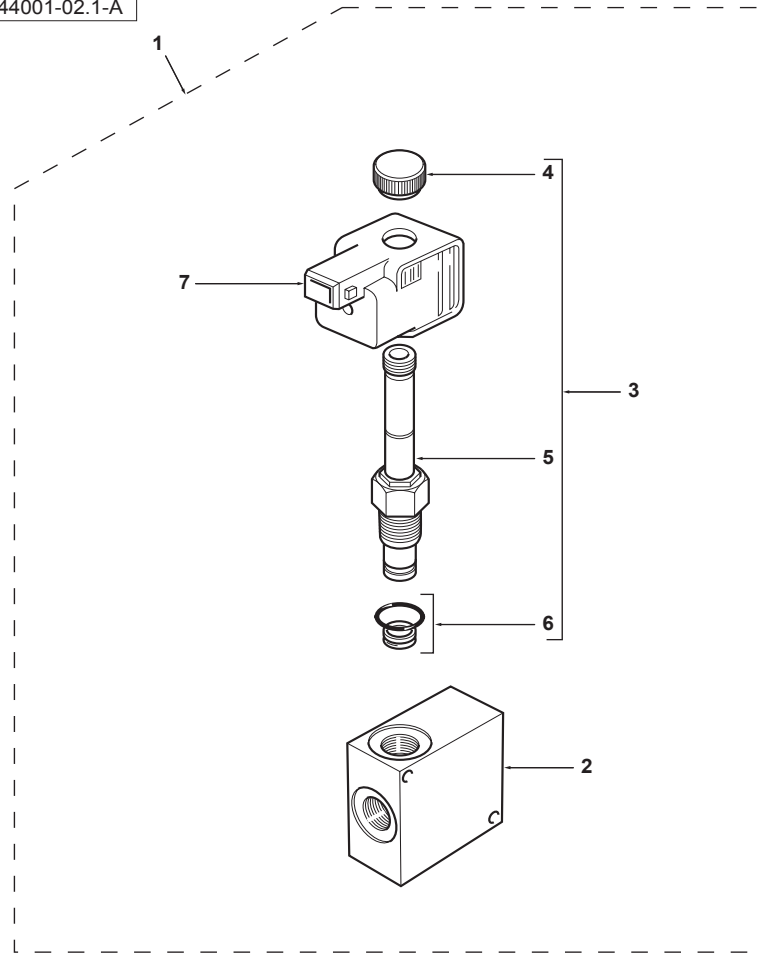

1	6098067M91		44001C01.1	1	Valve, Solenoid	Électrovalve	Electroválvula
2		1	Ref. 1	1	Body	Corps	Cuerpo
3	6190751M91	1		1	Solenoid Assy	Ensemble de solénoïde	Solenoide, Conj.
4		3	Ref. 3	1	Nut	Écrou	Tuerca
5		3	Ref. 3	1	Spool	Tiroir	Cajoncillo
6	6191365M91	3		1	Kit, Parts	Lot de pièces	Juego de piezas
7	6191096M91	1	12V	1	Coil	Bobine	Bobina



820 860 880
 TX760B TX860B
 TX870B

801 802 803 804 805 806 807 808 809 810 811 812 813 814 815 816 817 831 832
 833 834 841 842 843 844 845

44001C02.1

6199042M3

1

Jan-06

Drive Line Bolting
Boulonnage
Fijación con pernos

C-28010-01.1-B

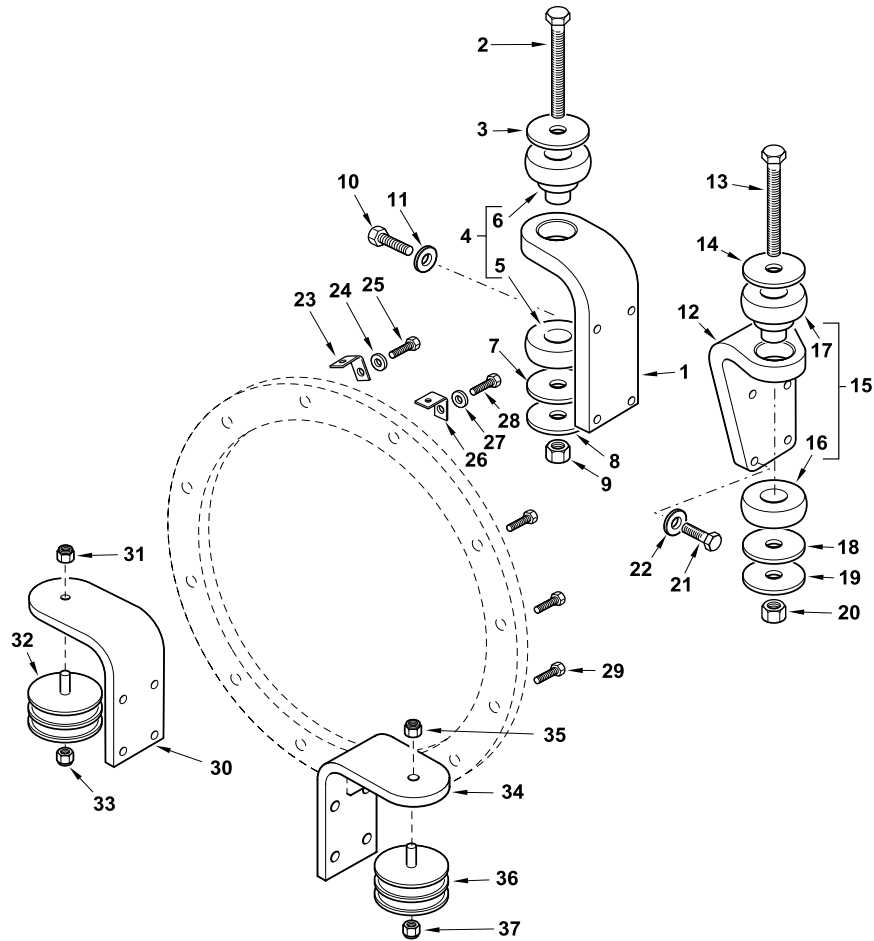

1	6109046M1		▶	1	Support	Support	Soporte
2	6007822M1	M16 x 120		1	Bolt	Boulon	Perno
3	6106849M1			1	Washer	Rondelle	Arandela
4	6106848M91			1	Mount	Support de fixation	Soporte de fijación
5			4 ▶ Ref. 4	1	Mount	Support de fixation	Soporte de fijación
6			4 ▶ Ref. 4	1	Mount	Support de fixation	Soporte de fijación
7	6106849M1			1	Washer	Rondelle	Arandela
8	6106849M1			1	Washer	Rondelle	Arandela
9	3516756M1	M16		1	Nut	Écrou	Tuerca
10	1440717X1	M12 x 40		4	Bolt	Boulon	Perno
11	3516702M1			4	Washer	Rondelle	Arandela
12	6109067M1		◀	1	Support	Support	Soporte
13	6007822M1	M16 x 120		1	Bolt	Boulon	Perno
14	6106849M1			1	Washer	Rondelle	Arandela
15	6106848M91			1	Mount	Support de fixation	Soporte de fijación
16			15 ▶ Ref. 15	1	Mount	Support de fixation	Soporte de fijación
17			15 ▶ Ref. 15	1	Mount	Support de fixation	Soporte de fijación
18	6106849M1			1	Washer	Rondelle	Arandela
19	6106849M1			1	Washer	Rondelle	Arandela
20	3516756M1	M16		1	Nut	Écrou	Tuerca
21	1440717X1	M12 x 40		4	Bolt	Boulon	Perno
22	3516702M1			4	Washer	Rondelle	Arandela
23	6109883M1			1	Bracket	Patte de fixation	Pata de fijación
24	385362X1	M10		1	Washer	Rondelle	Arandela
25	392892X1	M10 x 35		1	Bolt	Boulon	Perno
26	6109883M1			1	Bracket	Patte de fixation	Pata de fijación
27	385362X1	M10		1	Washer	Rondelle	Arandela
28	392892X1	M10 x 35		1	Bolt	Boulon	Perno
29	392892X1	M10 x 35		10	Bolt	Boulon	Perno
30	6110601M91	Engine		1	Mount	Support de fixation	Soporte de fijación
31	1440329X1	M10		1	Nut, Lock	Écrou de blocage	Tuerca de retención
32	3521357M1			1	Insulator Block	Bloc isolant	Bloque aislante
33	1440329X1	M10		1	Nut, Lock	Écrou de blocage	Tuerca de retención
34	6110601M91	Engine		1	Mount	Support de fixation	Soporte de fijación
35	1440329X1	M10		1	Nut, Lock	Écrou de blocage	Tuerca de retención
36	3521357M1			1	Insulator Block	Bloc isolant	Bloque aislante
37	1440329X1	M10		1	Nut, Lock	Écrou de blocage	Tuerca de retención



820 860 880
 TX760B TX860B
 TX870B

801 802 803 804 805 806 807 808 809 810 811 812 813 814 815 816 817 831 832
 833 834 841 842 843 844 845

28010C01.1

6199042M3

1

Jan-06

Drive Line Bolting
 Boulonnage
 Fijación con pernos

Powershift
 Powershift
 Powershift

C-28011-01.1-B

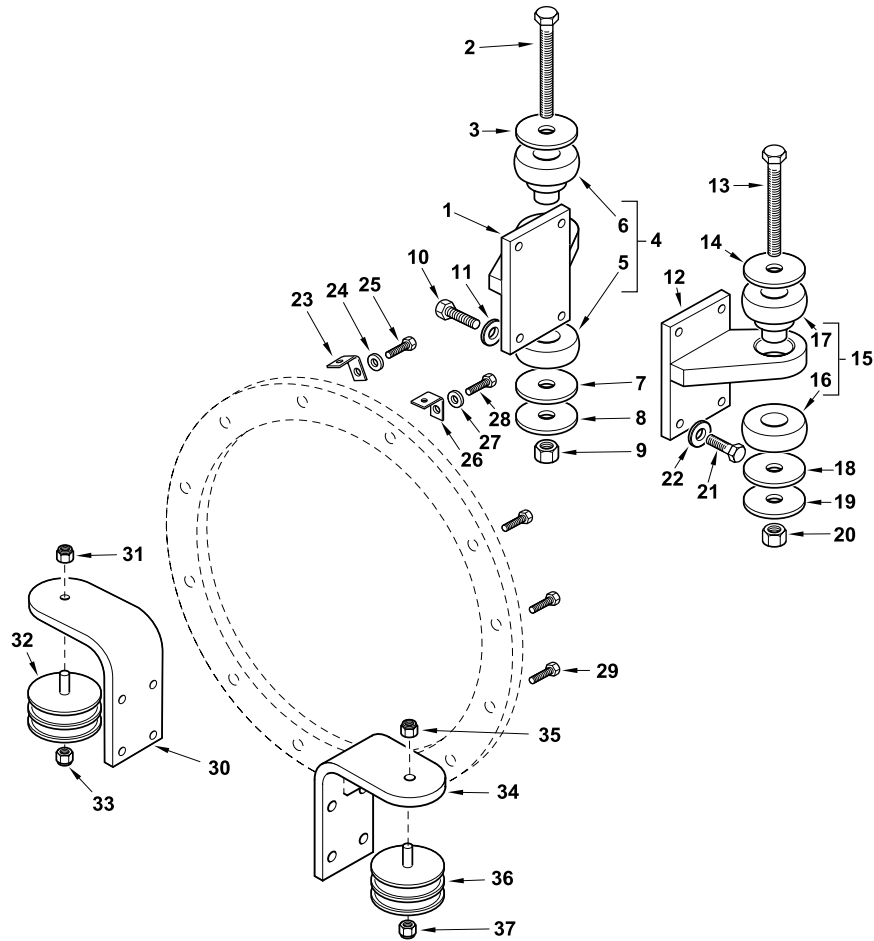

1	6109045M91		1	Support Assy	Ensemble de support	Apoyadero, Conj.
2	6007822M1	M16 x 120	1	Bolt	Boulon	Perno
3	6106849M1		1	Washer	Rondelle	Arandela
4	6106848M91		1	Mount	Support de fixation	Soporte de fijación
5		4 Ref. 4	1	Mount	Support de fixation	Soporte de fijación
6		4 Ref. 4	1	Mount	Support de fixation	Soporte de fijación
7	6106849M1		1	Washer	Rondelle	Arandela
8	6106849M1		1	Washer	Rondelle	Arandela
9	3516756M1	M16	1	Nut	Écrou	Tuerca
10	391934X1	M12 x 35	4	Screw	Vis	Tornillo
11	3516702M1		4	Washer	Rondelle	Arandela
12	6109044M91		1	Support Assy	Ensemble de support	Apoyadero, Conj.
13	6007822M1	M16 x 120	1	Bolt	Boulon	Perno
14	6106849M1		1	Washer	Rondelle	Arandela
15	6106848M91		1	Mount	Support de fixation	Soporte de fijación
16		15 Ref. 15	1	Mount	Support de fixation	Soporte de fijación
17		15 Ref. 15	1	Mount	Support de fixation	Soporte de fijación
18	6106849M1		1	Washer	Rondelle	Arandela
19	6106849M1		1	Washer	Rondelle	Arandela
20	3516756M1	M16	1	Nut	Écrou	Tuerca
21	391934X1	M12 x 35	4	Screw	Vis	Tornillo
22	3516702M1		4	Washer	Rondelle	Arandela
23	6109883M1		1	Bracket	Patte de fixation	Pata de fijación
24	385362X1	M10	1	Washer	Rondelle	Arandela
25	392892X1	M10 x 35	1	Bolt	Boulon	Perno
26	6109883M1		1	Bracket	Patte de fixation	Pata de fijación
27	385362X1	M10	1	Washer	Rondelle	Arandela
28	392892X1	M10 x 35	1	Bolt	Boulon	Perno
29	392892X1	M10 x 35	10	Bolt	Boulon	Perno
30	6110601M91	Engine	1	Mount	Support de fixation	Soporte de fijación
31	1440329X1	M10	1	Nut, Lock	Écrou de blocage	Tuerca de retención
32	3521357M1		1	Insulator Block	Bloc isolant	Bloque aislante
33	1440329X1	M10	1	Nut, Lock	Écrou de blocage	Tuerca de retención
34	6110601M91	Engine	1	Mount	Support de fixation	Soporte de fijación
35	1440329X1	M10	1	Nut, Lock	Écrou de blocage	Tuerca de retención
36	3521357M1		1	Insulator Block	Bloc isolant	Bloque aislante
37	1440329X1	M10	1	Nut, Lock	Écrou de blocage	Tuerca de retención



860 880 970 980
 TX860B TX870B
 TX970B

821 822 823 824 825 851 852 853 854 855 921 922 923 931 932

28011C01.1

6199042M3

1

Jan-06

Drive Line Bolting
Boulonnage
Fijación con pernos

C-28012-01.1-B

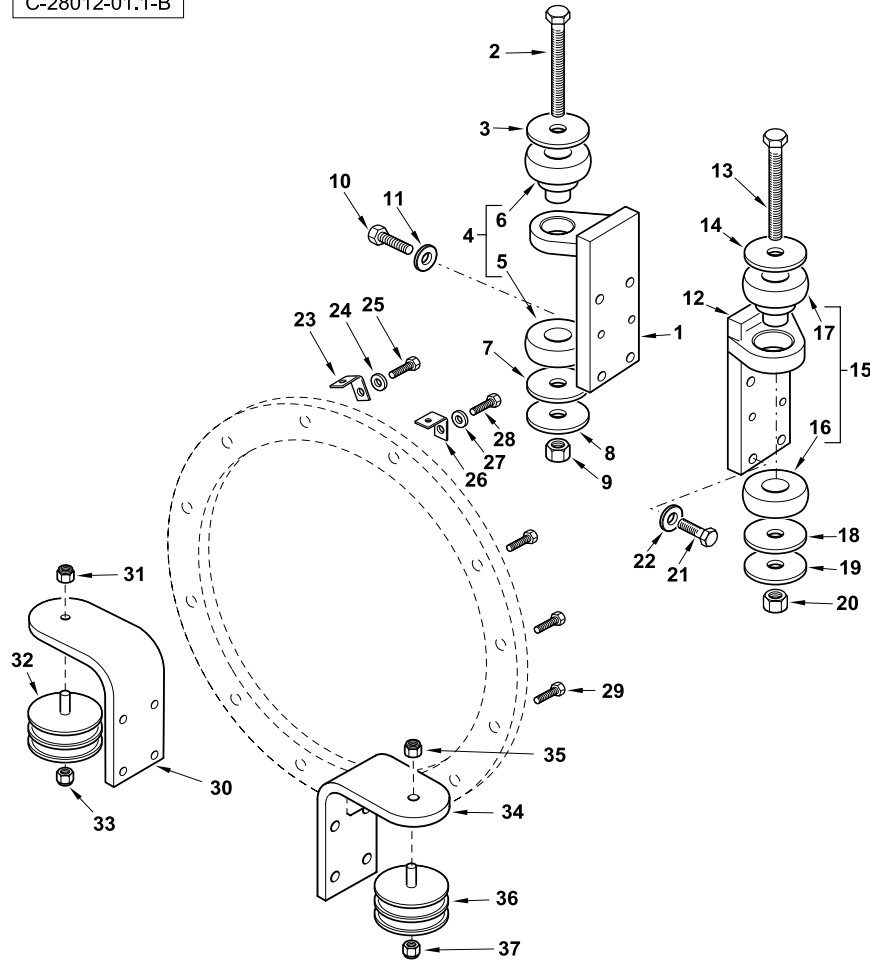

1	6110557M91		▶	1	Support Assy	Ensemble de support	Apoyadero, Conj.
2	6007822M1	M16 x 120		1	Bolt	Boulon	Perno
3	6106849M1			1	Washer	Rondelle	Arandela
4	6106848M91			1	Mount	Support de fixation	Soporte de fijación
5			4 ▶ Ref. 4	1	Mount	Support de fixation	Soporte de fijación
6			4 ▶ Ref. 4	1	Mount	Support de fixation	Soporte de fijación
7	6106849M1			1	Washer	Rondelle	Arandela
8	6106849M1			1	Washer	Rondelle	Arandela
9	3516756M1	M16		1	Nut	Écrou	Tuerca
10	1440717X1	M12 x 40		4	Bolt	Boulon	Perno
11	3516702M1			4	Washer	Rondelle	Arandela
12	6110556M91		◀	1	Support Assy	Ensemble de support	Apoyadero, Conj.
13	6007822M1	M16 x 120		1	Bolt	Boulon	Perno
14	6106849M1			1	Washer	Rondelle	Arandela
15	6106848M91			1	Mount	Support de fixation	Soporte de fijación
16			15 ▶ Ref. 15	1	Mount	Support de fixation	Soporte de fijación
17			15 ▶ Ref. 15	1	Mount	Support de fixation	Soporte de fijación
18	6106849M1			1	Washer	Rondelle	Arandela
19	6106849M1			1	Washer	Rondelle	Arandela
20	3516756M1	M16		1	Nut	Écrou	Tuerca
21	1440717X1	M12 x 40		4	Bolt	Boulon	Perno
22	3516702M1			4	Washer	Rondelle	Arandela
23	6109883M1			1	Bracket	Patte de fixation	Pata de fijación
24	385362X1	M10		1	Washer	Rondelle	Arandela
25	392892X1	M10 x 35		1	Bolt	Boulon	Perno
26	6109883M1			1	Bracket	Patte de fixation	Pata de fijación
27	385362X1	M10		1	Washer	Rondelle	Arandela
28	392892X1	M10 x 35		1	Bolt	Boulon	Perno
29	392892X1	M10 x 35		10	Bolt	Boulon	Perno
30	6110601M91	Engine		1	Mount	Support de fixation	Soporte de fijación
31	1440329X1	M10		1	Nut, Lock	Écrou de blocage	Tuerca de retención
32	3521357M1			1	Insulator Block	Bloc isolant	Bloque aislante
33	1440329X1	M10		1	Nut, Lock	Écrou de blocage	Tuerca de retención
34	6110601M91	Engine		1	Mount	Support de fixation	Soporte de fijación
35	1440329X1	M10		1	Nut, Lock	Écrou de blocage	Tuerca de retención
36	3521357M1			1	Insulator Block	Bloc isolant	Bloque aislante
37	1440329X1	M10		1	Nut, Lock	Écrou de blocage	Tuerca de retención



820 860 880
 TX760B TX860B
 TX870B

803 804 807 808 813 814 815 816 817 841 842 843 844 845

28012C01.1

6199042M3

1

Jan-06

Gear Change
Changement de Vitesses
Cambio de velocidades

Control Lever
Levier de Commande
Palanca de mando

4 Speed
 4 Vitesses
 4 velocidades

C-31001-01.1-A

1	6108406M91		1	Grip	Poignée de levier	Empuñ. Palanca
2		1	▶ Ref. 1	Body	Corps	Cuerpo
3		1	▶ Ref. 1	Harness	Faisceau	Haz
4	3009422X1	1		Screw	Vis	Tornillo
5	1475805M1			Spring	Ressort	Muelle
6	3009511X1	M12 x 55		Bolt	Boulon	Perno
7	1440330X1	M12		Nut	Écrou	Tuerca
8	6101248M3			Boot	Soufflet	Fuelle
9	6101249M2			Retainer	Dispositif de retenue	Fijación
10	3521303M3			6 Fastener	Attache	Eganche
11	6109151M91			Lever Assy	Ensemble de levier	Palanca, Conj.
12	6101921M1			Decal	Adhésif	Adhesivo

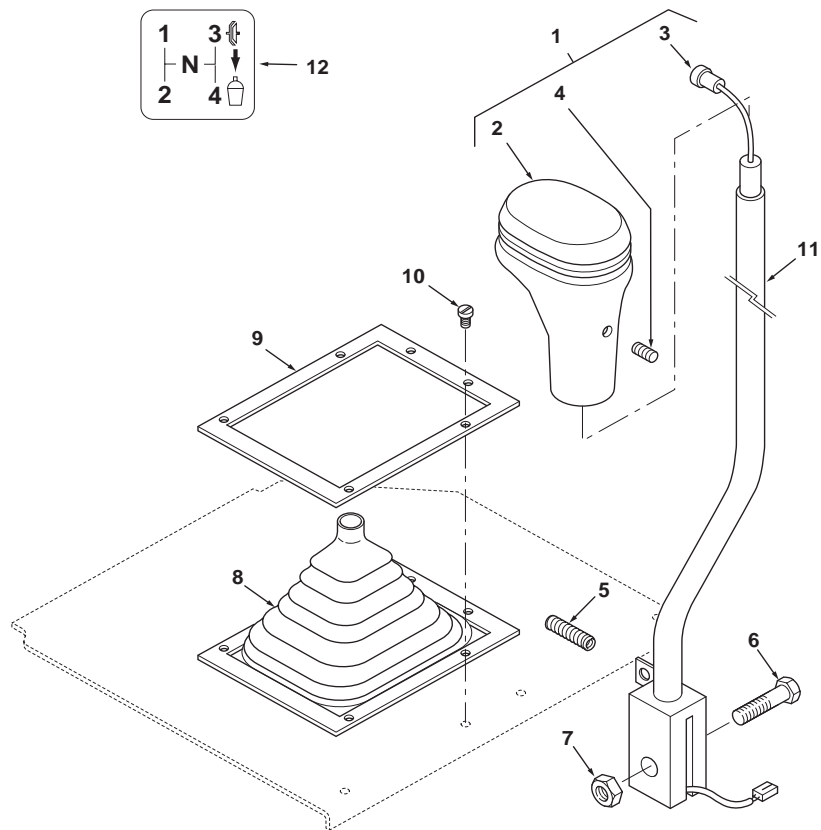

820 860 880
 TX760B TX860B
 TX870B

801 802 803 804 805 806 807 808 809 810 811 812 813 814 815 816 817 831 832
 833 834 841 842 843 844 845

31001C01.1

6199042M3

1

Jan-06

Gear Change
Changement de Vitesses
Cambio de velocidades

Control Lever
Levier de Commande
Palanca de mando

3 Speed
 3 Vitesses
 3 velocidades

C-31002-01.1-A

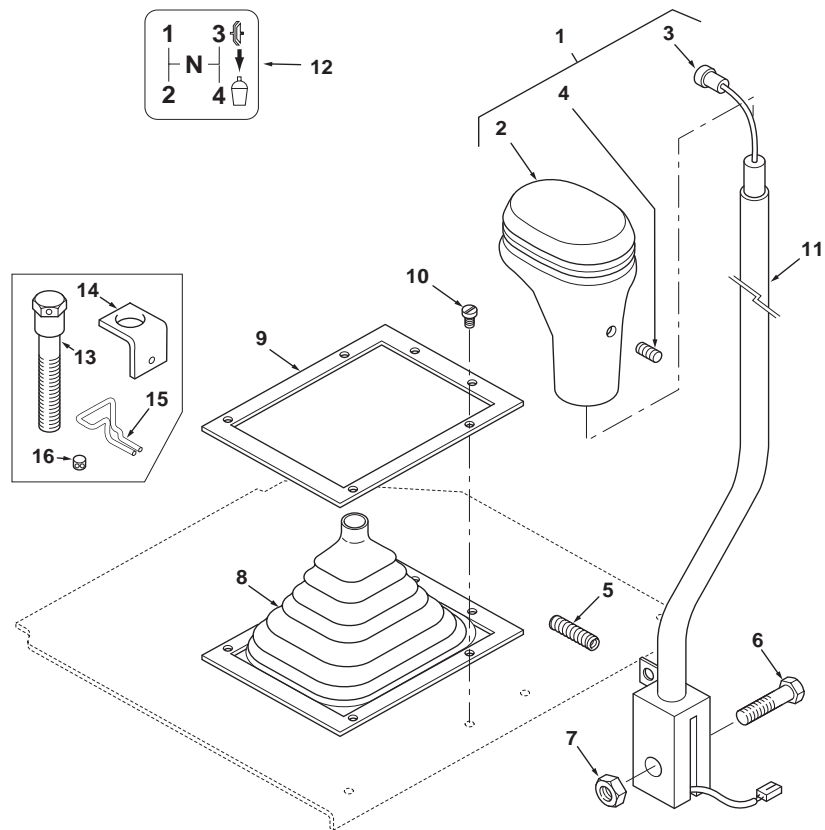

1	6108406M91		1	Grip	Poignée de levier	Empuñ. Palanca
2		1	Ref. 1	Body	Corps	Cuerpo
3		1	Ref. 1	Harness	Faisceau	Haz
4	3009422X1	1		Screw	Vis	Tornillo
5	1475805M1		1	Spring	Ressort	Muelle
6	3009511X1	M12 x 55	1	Bolt	Boulon	Perno
7	1440330X1	M12	1	Nut	Écrou	Tuerca
8	6101248M3		1	Boot	Soufflet	Fuelle
9	6101249M2		1	Retainer	Dispositif de retenue	Fijación
10	3521303M3		6	Fastener	Attache	Enganche
11	6109151M91		1	Lever Assy	Ensemble de levier	Palanca, Conj.
12	6101922M1		1	Decal	Adhésif	Adhesivo
13	3518655M1	Gear Locking	1	Screw	Vis	Tornillo
14	3518654M1		1	Bracket	Patte de fixation	Pata de fijación
15	3516868M1	Locking	1	Wire	Fil	Hilo
16	3516867M1	Lead	1	Seal	Joint	Junta



820 860 880
 TX760B TX860B

805 806 807 808 817 845

31002C01.1

6199042M3

1

Jan-06

Gear Change
Changement de Vitesses
Cambio de velocidades

Control Lever
Levier de Commande
Palanca de mando

4 Speed
 4 Vitesses
 4 velocidades

C-31006-01.1-A

1	6108406M91		1	Grip	Poignée de levier	Empuñ. Palanca
2		1	▶ Ref. 1	Body	Corps	Cuerpo
3		1	▶ Ref. 1	Harness	Faisceau	Haz
4	3009422X1	1		Screw	Vis	Tornillo
5	1475805M1			Spring	Ressort	Muelle
6	3009511X1	M12 x 55		Bolt	Boulon	Perno
7	1440330X1	M12		Nut	Écrou	Tuerca
8	6101248M3			Boot	Soufflet	Fuelle
9	6101249M2			Retainer	Dispositif de retenue	Fijación
10	3521303M3			Fastener	Attache	Eganche
11	6110562M91			Lever Assy	Ensemble de levier	Palanca, Conj.
12	6101921M1			Decal	Adhésif	Adhesivo

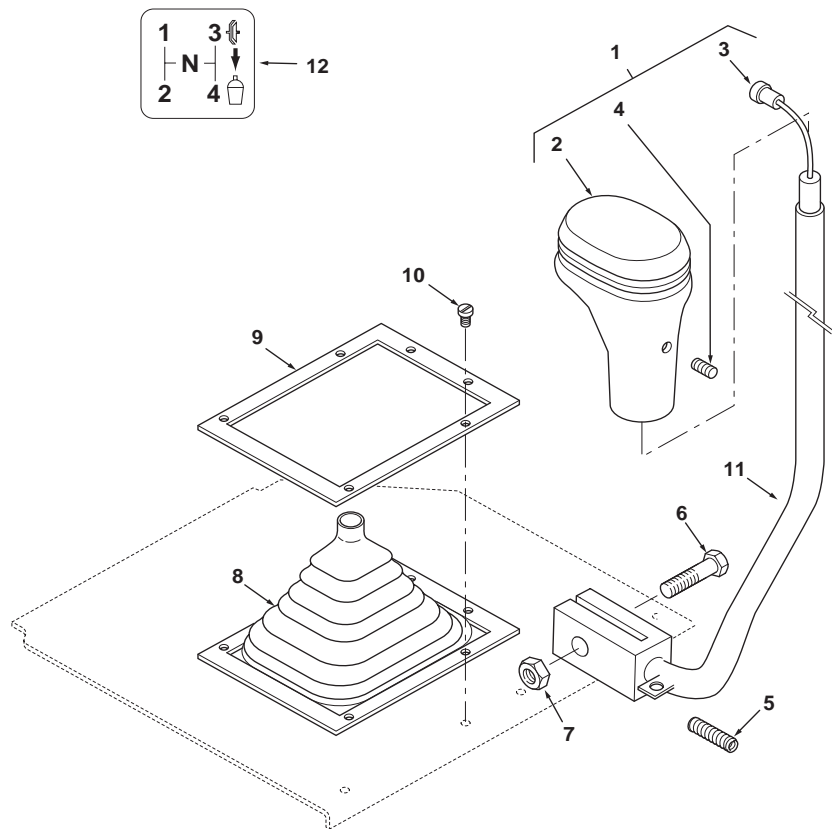

820 860 880
 TX760B TX860B
 TX870B

803 804 807 808 813 814 815 816 817 841 842 843 844 845

31006C01.1

6199042M3

1

Jan-06

Gear Change
Changement de Vitesses
Cambio de velocidades

Control Lever
Levier de Commande
Palanca de mando

3 Speed
 3 Vitesses
 3 velocidades

C-31007-01.1-A

1	6108406M91		1	Grip	Poignée de levier	Empuñ. Palanca
2		1	Ref. 1	Body	Corps	Cuerpo
3		1	Ref. 1	Harness	Faisceau	Haz
4	3009422X1	1		Screw	Vis	Tornillo
5	1475805M1			Spring	Ressort	Muelle
6	3009511X1	M12 x 55	1	Bolt	Boulon	Perno
7	1440330X1	M12	1	Nut	Écrou	Tuerca
8	6101248M3		1	Boot	Soufflet	Fuelle
9	6101249M2		1	Retainer	Dispositif de retenue	Fijación
10	3521303M3		6	Fastener	Attache	Enganche
11	6110562M91		1	Lever Assy	Ensemble de levier	Palanca, Conj.
12	6101922M1		1	Decal	Adhésif	Adhesivo
13	3518654M1		1	Bracket	Patte de fixation	Pata de fijación
14	3516868M1	Locking	1	Wire	Fil	Hilo
15	3516867M1	Lead	1	Seal	Joint	Junta

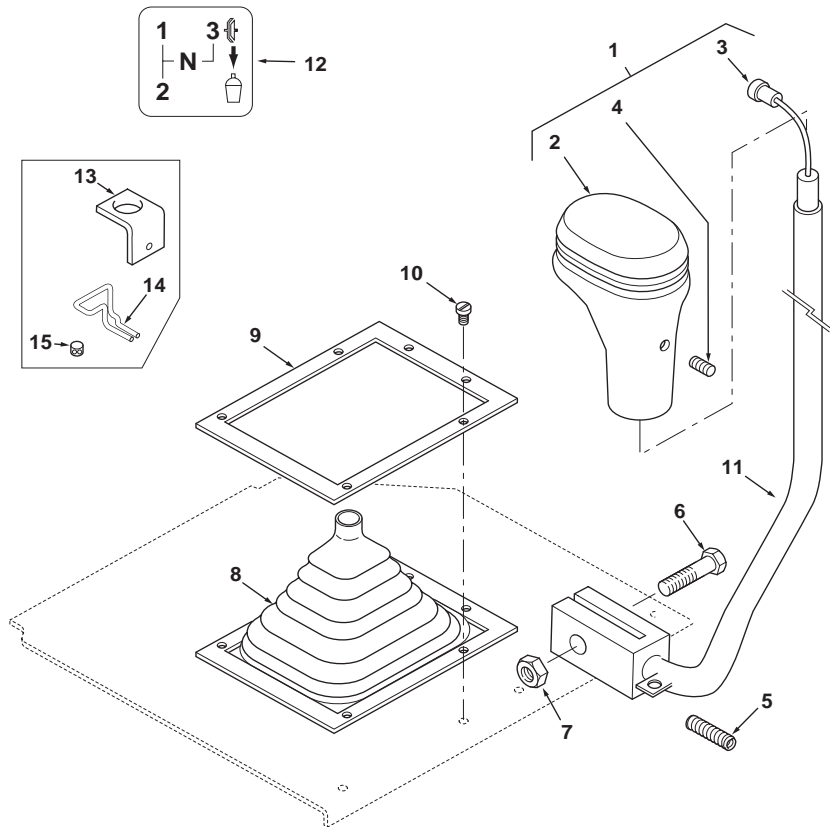

820 860 880
 TX760B TX860B

807 808 817 845

31007C01.1

6199042M3

1

Jan-06

Gear Change
Changement de Vitesses
Cambio de velocidades

Transmission Control Unit
Unité de Commande de Transmission
Unidad de control de transmisión

4 Speed
 4 Vitesses
 4 velocidades

C-31003-01.1-A

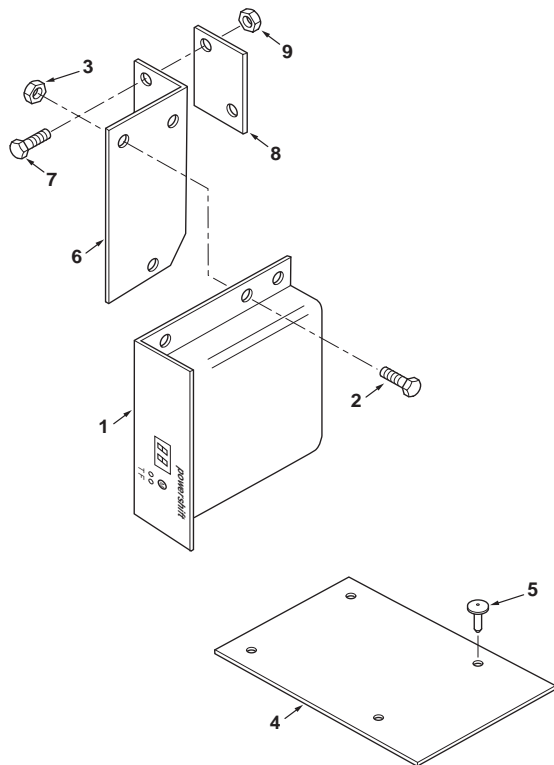

1	6109867M91		1	Control Unit	Unité de commande	Unidad de control
2	339560X1	M6 x 16	3	Screw	Vis	Tornillo
3	1441500X1	M6	3	Nut, Lock	Écrou de blocage	Tuerca de retención
4	6106390M1		1	Cover	Cache	Tapa
5	3521303M3		4	Fastener	Attache	Enganche
6	6108075M2		1	Bracket	Patte de fixation	Pata de fijación
7	3009492X1	M10 x 25	2	Screw	Vis	Tornillo
8	6108339M1		1	Seal	Joint	Junta
9	1440329X1	M10	2	Nut, Lock	Écrou de blocage	Tuerca de retención



860 880
 TX860B TX870B

821 822 823 824 825 851 852 853 854 855

31003C01.1

6199042M3

1

Jan-06

Gear Change
Changement de Vitesses
Cambio de velocidades

Transmission Control Unit
Unité de Commande de Transmission
Unidad de control de transmisión

4 Speed
 4 Vitesses
 4 velocidades

C-31004-01.1-A

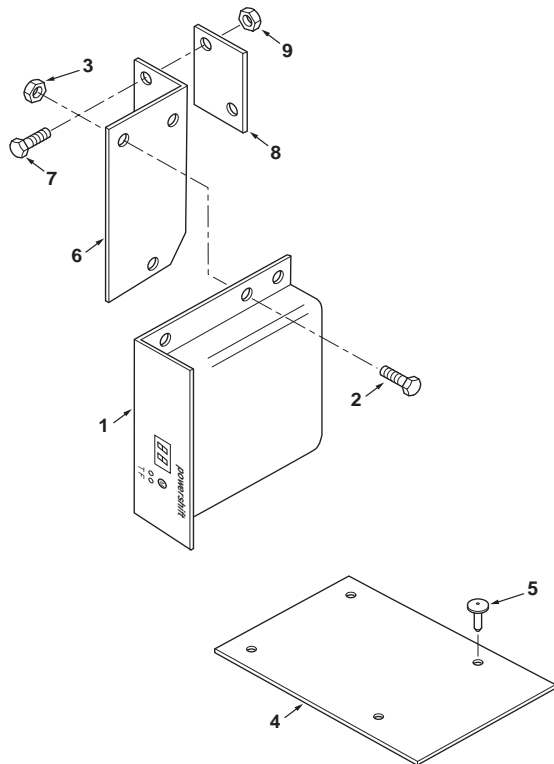

1	6109868M91		1	Control Unit	Unité de commande	Unidad de control
2	339560X1	M6 x 16	3	Screw	Vis	Tornillo
3	1441500X1	M6	3	Nut, Lock	Écrou de blocage	Tuerca de retención
4	6106390M1		1	Cover	Cache	Tapa
5	3521303M3		4	Fastener	Attache	Enganche
6	6108075M2		1	Bracket	Patte de fixation	Pata de fijación
7	3009492X1	M10 x 25	2	Screw	Vis	Tornillo
8	6108339M1		1	Seal	Joint	Junta
9	1440329X1	M10	2	Nut, Lock	Écrou de blocage	Tuerca de retención



970 980
 TX970B

921 922 923 931 932

31004C01.1

6199042M3

1

Jan-06

Gear Change
Changement de Vitesses
Cambio de velocidades

Transmission Control Unit
Unité de Commande de Transmission
Unidad de control de transmisión

3 Speed
 3 Vitesses
 3 velocidades

C-31005-01.1-A

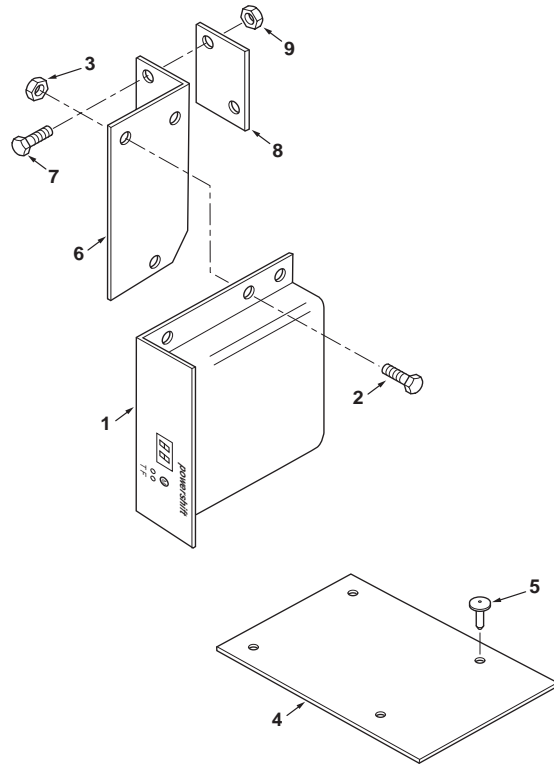

1	6109869M91		1	Control Unit	Unité de commande	Unidad de control
2	339560X1	M6 x 16	3	Screw	Vis	Tornillo
3	1441500X1	M6	3	Nut, Lock	Écrou de blocage	Tuerca de retención
4	6106390M1		1	Cover	Cache	Tapa
5	3521303M3		4	Fastener	Attache	Enganche
6	6108075M2		1	Bracket	Patte de fixation	Pata de fijación
7	3009492X1	M10 x 25	2	Screw	Vis	Tornillo
8	6108339M1		1	Seal	Joint	Junta
9	1440329X1	M10	2	Nut, Lock	Écrou de blocage	Tuerca de retención



860 880
 TX860B TX870B

825 851 853 855

31005C01.1

6199042M3

1

Jan-06

Parking Brake
Frein à Main
Freno de aparcamiento

C-45001-01.1-A

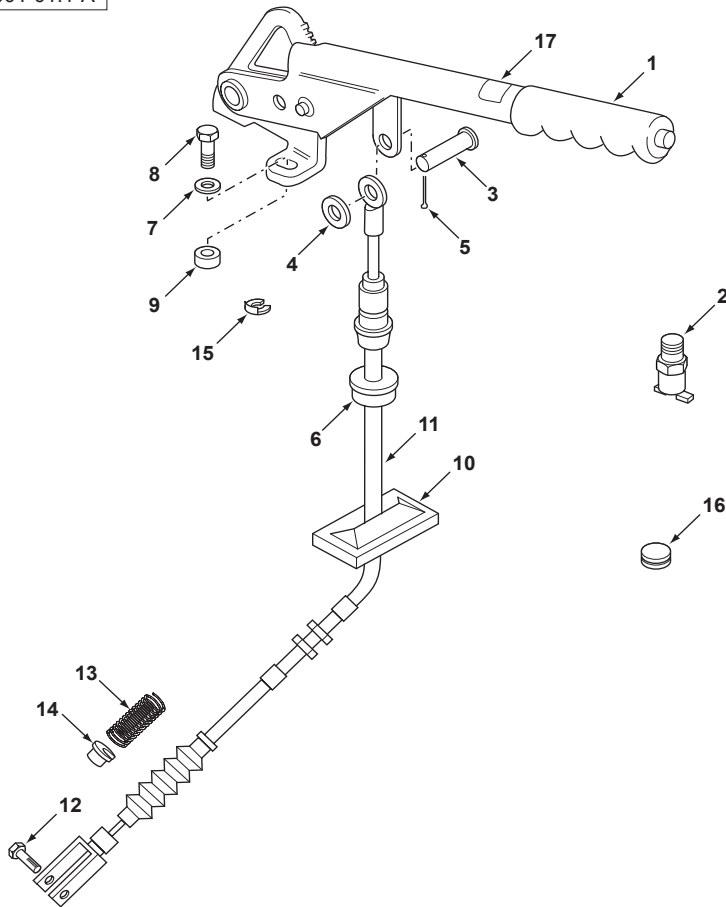

1	3519890M91		1	Lever, Brake	Levier de frein	Palanca de freno
2	6107867M91	Brake light	1	Switch Assy	Ensemble commutat.	Conmutador, Conj.
3	376401X1		1	Pin	Axe	Pasador
4	353756X1		1	Washer	Rondelle	Arandela
5	1442992X1		1	Pin, Split	Goupille	Pasador
6	6102367M1		1	Grommet	Passe-fil	Pasa cable
7	390734X1	M10	2	Washer	Rondelle	Arandela
8	3009492X1	M10 x 25	2	Screw	Vis	Tornillo
9	3516293M1	18 x 11 x 6 mm	2	Spacer	Entretoise	Traviesa
10	6006361M2		1	Grommet	Passe-fil	Pasa cable
11	6107032M91		1	Cable Assy	Ensemble de câble	Cable, Conj.
12	6107031M1		1	Pin	Axe	Pasador
13	3518052M2		1	Spring	Ressort	Muelle
14	3518051M1		1	Holder	Porte-injecteur	Retén
15	1696650M1		1	Ring, Snap	Anneau d'arrêt	Anillo de resorte
16	3516323M1		2	Grommet	Passe-fil	Pasa cable
17	3516652M1		1	Decal	Adhésif	Adhesivo



820 860 880 970 980
 TX760B TX860B
 TX870B TX970B

801 803 805 807 809 811 813 815 817 821 823 825 831 833 834 841 843 845 851
 853 854 855 921 922 923 931 932

Parking Brake
Frein à Main
Freno de aparcamiento

4 Post ROPS
 4 Poteau ROPS
 4 poste ROPS

C-45002-01.1-A

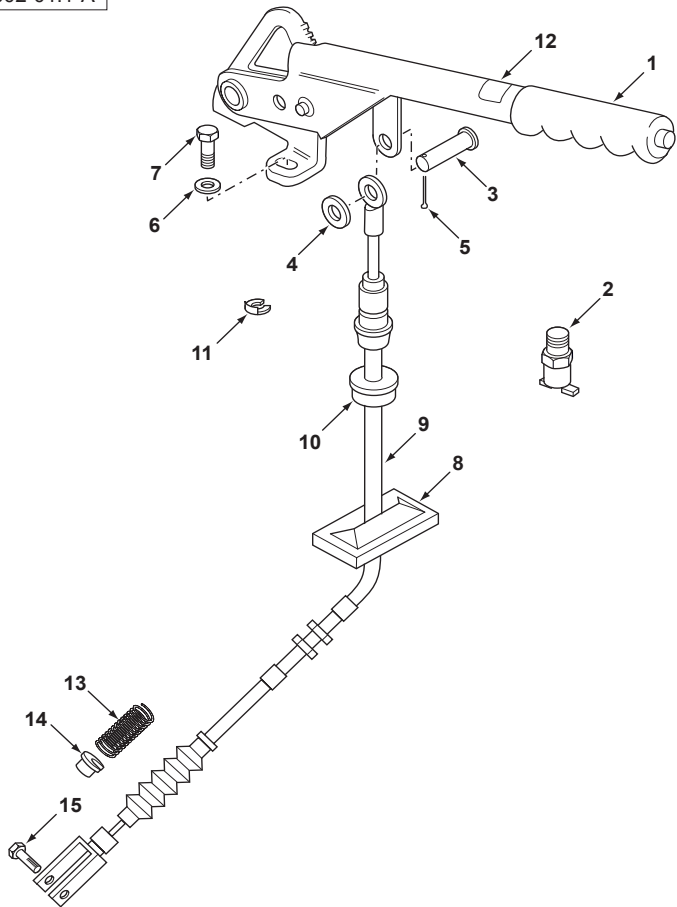

1	3519890M91		1	Lever, Brake	Levier de frein	Palanca de freno
2	6107867M91	Brake light	1	Switch Assy	Ensemble commutat.	Conmutador, Conj.
3	376401X1		1	Pin	Axe	Pasador
4	353756X1		1	Washer	Rondelle	Arandela
5	1442992X1		1	Pin, Split	Goupille	Pasador
6	390734X1	M10	2	Washer	Rondelle	Arandela
7	3009492X1	M10 x 25	2	Screw	Vis	Tornillo
8	6006361M2		1	Grommet	Passe-fil	Pasa cable
9	6107032M91		1	Cable Assy	Ensemble de câble	Cable, Conj.
10	6102367M1		1	Grommet	Passe-fil	Pasa cable
11	1696650M1		1	Ring, Snap	Anneau d'arrêt	Anillo de resorte
12	3516652M1		1	Decal	Adhésif	Adhesivo
13	3518052M2		1	Spring	Ressort	Muelle
14	3518051M1		1	Holder	Porte-injecteur	Retén
15	6107031M1		1	Pin	Axe	Pasador



820 860 880
 TX760B TX860B
 TX870B

802 804 806 808 810 812 814 816 822 824 832 842 844 852 854

45002C01.1

6199042M3

1

Jan-06

Rear Axle
Essieu Arrière
Eje trasero

2 Wheel Steer
2 Roues Directrices
Dirección en 2 ruedas

C-37001-01.1-A

1	6109183M91		1	Axle Assy, Rear	Mont. d'essieu, arrière	Puente trasero, Conj.
2	6106980M1	M20 x 230	8	Bolt	Boulon	Perno
3	385365X1	M20	8	Washer	Rondelle	Arandela
4	6106096M1		2	Plate	Plaque	Placa
5	385365X1	M20	8	Washer	Rondelle	Arandela
6	3522225M3	M20	8	Nut	Écrou	Tuerca
7	6106829M91		20	Nut	Écrou	Tuerca

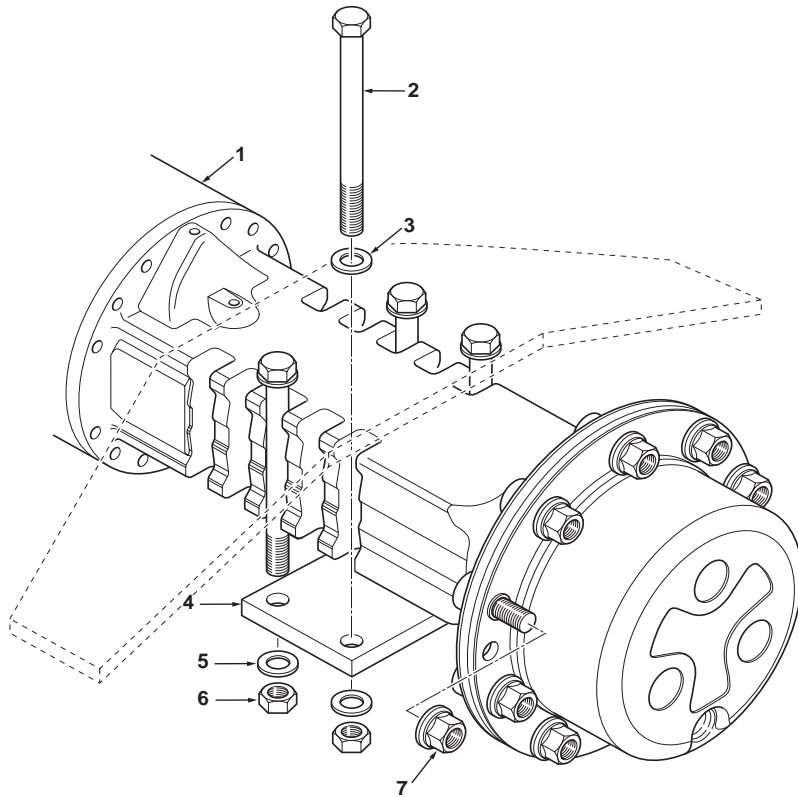

820 860 880
TX760B TX860B
TX870B

801 802 803 804 805 806 807 808 809 810 811 812 813 814 815 816 817 831 832
833 834 841 842 843 844 845

37001C01.1

6199042M3

1

Jan-06

Rear Axle
Essieu Arrière
Eje trasero

2 Wheel Steer
2 Roues Directrices
Dirección en 2 ruedas

C-37002-01.1-A

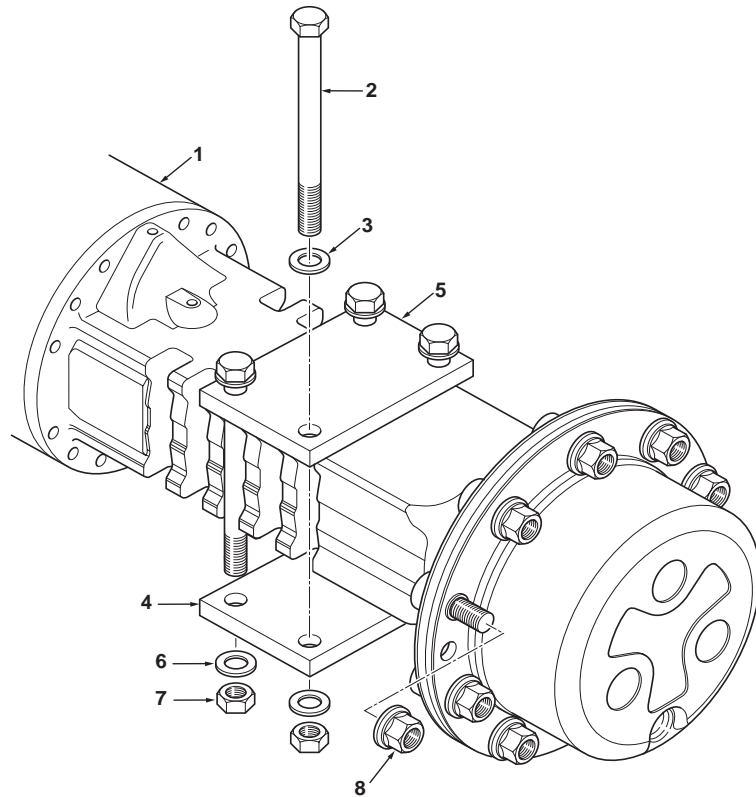

1	6109184M91		1	Axle Assy, Rear	Mont. d'essieu, arrière	Puente trasero, Conj.
2	6106177M1	M20 x 250	8	Bolt	Boulon	Perno
3	385365X1	M20	8	Washer	Rondelle	Arandela
4	6106096M1		2	Plate	Plaque	Placa
5	6106096M1		2	Plate	Plaque	Placa
6	385365X1	M20	8	Washer	Rondelle	Arandela
7	3522225M3	M20	8	Nut	Écrou	Tuerca
8	6106829M91		20	Nut	Écrou	Tuerca



860 880
TX860B TX870B

821 822 823 824 825 851 852 853 854 855

37002C01.1

6199042M3

1

Jan-06

Rear Axle
Essieu Arrière
Eje trasero

4 Wheel Steer
4 Roues Directrices
Dirección en las 4 ruedas

C-37003-01.1-A

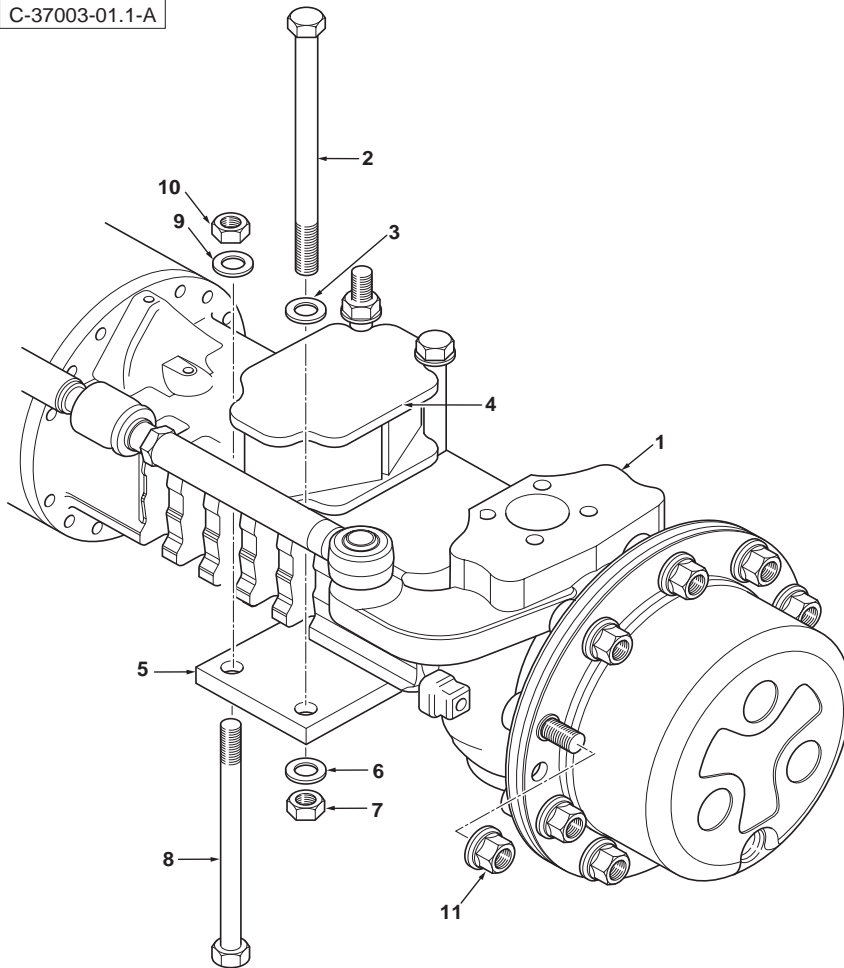

1	6109185M91	Ref: 148405	1	Axle Assy, Rear	Mont. d'essieu, arrière	Puente trasero, Conj.
2	6106488M1	M20 x 330	4	Bolt	Boulon	Perno
3	385365X1	M20	4	Washer	Rondelle	Arandela
4	6106487M91		2	Spacer Assy	Ensemble d'entretoise	Traviesa, Conj.
5	6106096M1		2	Plate	Plaque	Placa
6	385365X1	M20	4	Washer	Rondelle	Arandela
7	3522225M3	M20	4	Nut	Écrou	Tuerca
8	6106488M1	M20 x 330	4	Bolt	Boulon	Perno
9	385365X1	M20	4	Washer	Rondelle	Arandela
10	3522225M3	M20	4	Nut	Écrou	Tuerca
11	6106829M91		20	Nut	Écrou	Tuerca



970 980
 TX970B

921 922 923 931 932

37003C01.1

6199042M3

1

Jan-06

Rear Axle
Essieu Arrière
Eje trasero

2 Wheel Steer
2 Roues Directrices
Dirección en 2 ruedas

C-37004-01.1-A

1	6110550M91		1	Axle Assy, Rear	Mont. d'essieu, arrière	Puente trasero, Conj.
2	6106980M1	M20 x 230	8	Bolt	Boulon	Perno
3	385365X1	M20	8	Washer	Rondelle	Arandela
4	6106096M1		2	Plate	Plaque	Placa
5	385365X1	M20	8	Washer	Rondelle	Arandela
6	3522225M3	M20	8	Nut	Écrou	Tuerca
7	6106829M91		20	Nut	Écrou	Tuerca

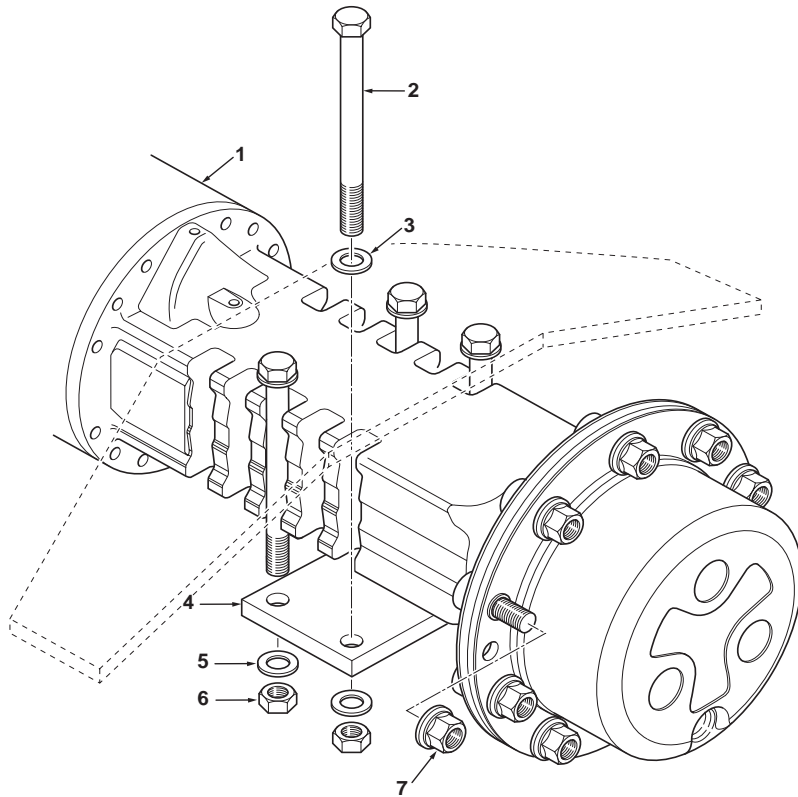

820 860 880
TX760B TX860B
TX870B

803 804 807 808 813 814 815 816 817 841 842 843 844 845

37004C01.1

6199042M3

1

Jan-06

Rear Axle
Essieu Arrière
Eje trasero

2 Wheel Steer
 2 Roues Directrices
 Dirección en 2 ruedas

C-37004-02.1-A

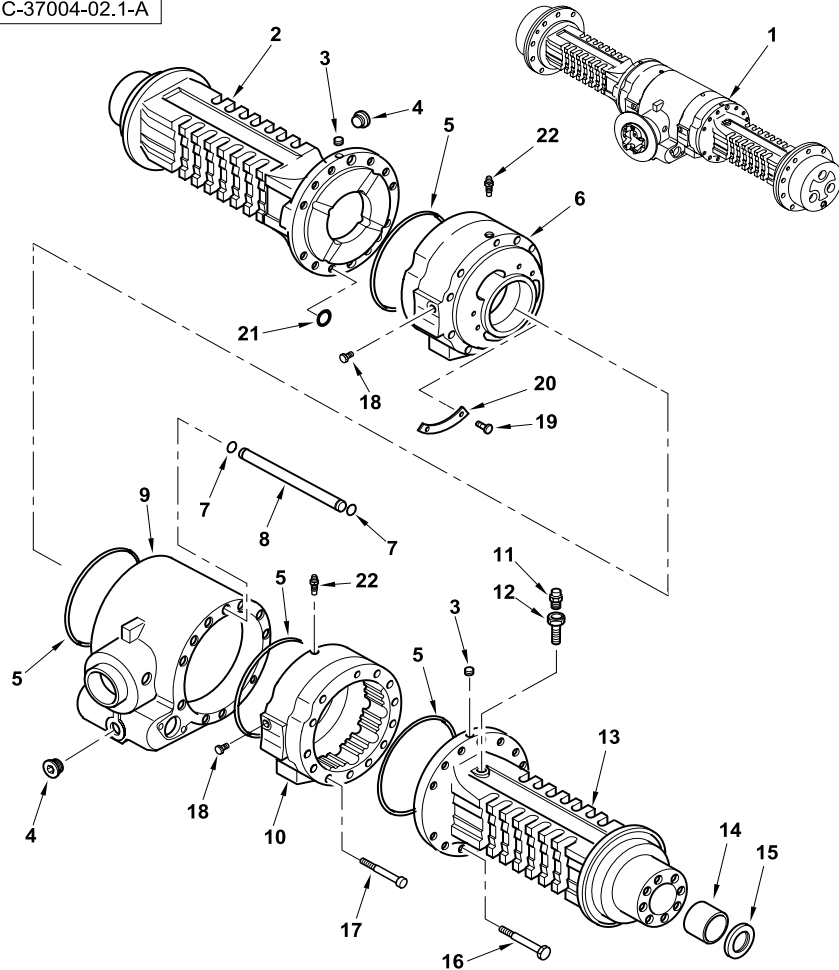

1	6110550M91		1	Axle Assy, Rear	Mont. d'essieu, arrière	Puente trasero, Conj.
2	6193332M1		1	Housing, Axle	Carter de pont	Cárter de puente
3	3523998M1	M10 x 1	2	Plug	Bouchon	Tapón
4	3523632M1	M30 x 2	2	Plug	Bouchon	Tapón
5	6193333M1		4	O-Ring	Joint torique	Junta de tipo O
6	6193334M1		1	Cylinder, Brake	Cylindre, frein	Pistón de freno
7	3523630M1		2	O-Ring	Joint torique	Junta de tipo O
8	6193335M1		1	Pipe	Tuyau	Tubo
9	6193336M1		1	Housing Assy, Center	Ensemble carter centr	Cárter central, Conj.
10	6193337M1		1	Cylinder, Brake	Cylindre, frein	Pistón de freno
11	3475328M1	M10	1	Breather	Reniflard	Ventilador del cárter
12	6193338M1	Breather	1	Pipe	Tuyau	Tubo
13	6193339M1		1	Housing, Axle	Carter de pont	Cárter de puente
14	6193340M1		2	Bushing	Bague	Anillo
15	6193341M1		2	Seal, Ring	Joint, anneau	Junta de anillo
16	6193342M1	M14 x 140	22	Bolt	Boulon	Perno
17	6193343M1	M12 x 130	2	Bolt	Boulon	Perno
18	6193344M1		2	Plug	Bouchon	Tapón
19	6193345M1	M4.8 x 6	4	Rivet	Rivet	Remache
20	6193346M1		2	Plate	Plaque	Placa
21	6193347M1		8	O-Ring	Joint torique	Junta de tipo O
22	6190624M1		2	Screw, Bleed	Vis de purge	Tornillo purgador



820 860 880
 TX760B TX860B
 TX870B

803 804 807 808 813 814 815 816 817 841 842 843 844 845

37004C02.1

6199042M3

1

Jan-06

Rear Axle
Essieu Arrière
Eje trasero

2 Wheel Steer
 2 Roues Directrices
 Dirección en 2 ruedas

C-37004-03.1-A

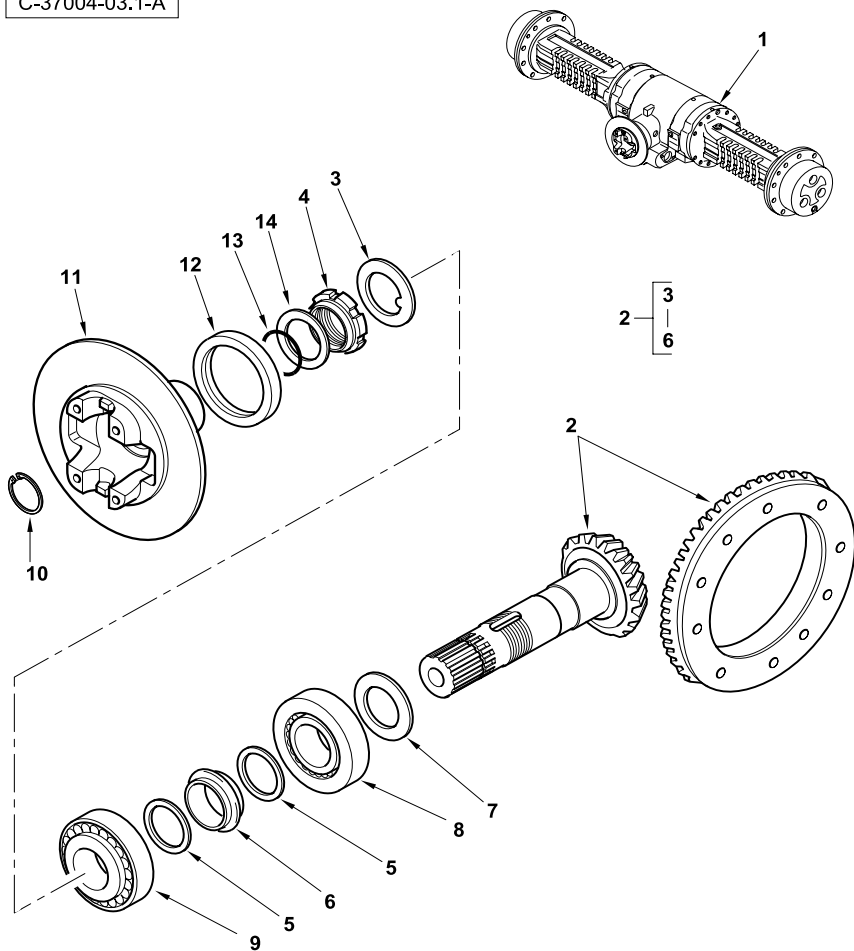

1	6110550M91			1	Axle Assy, Rear	Mont. d'essieu, arrière	Puente trasero, Conj.
2	6194510M91	1	15/37	1	Bevel gear/Pinion set	Jeu Engrenage conique/ Pignon	Engranaje cónico/piñón
3	3475569M1	2		1	Washer, Lock	Rondelle de blocage	Arandela de freno
4	3475570M1	2	M40	1	Nut	Écrou	Tuerca
5	3523082M1	2		2	Washer	Rondelle	Arandela
6	6193350M1	2		1	Spacer	Entretoise	Traviesa
7	6193351M1		2.50 mm	1	Shim	Cale	Calce
7	6193352M1		2.60 mm	1	Shim	Cale	Calce
7	6193353M1		2.70 mm	1	Shim	Cale	Calce
7	6193354M1		2.80 mm	1	Shim	Cale	Calce
7	6193355M1		2.90 mm	1	Shim	Cale	Calce
7	6193356M1		3.00 mm	1	Shim	Cale	Calce
7	6193357M1		3.10 mm	1	Shim	Cale	Calce
7	6193358M1		3.20 mm	1	Shim	Cale	Calce
7	6193359M1		3.30 mm	1	Shim	Cale	Calce
7	6193360M1		3.40 mm	1	Shim	Cale	Calce
8	6193361M1			1	Bearing	Coussinet	Cojinete
9	3475567M1			1	Bearing, Ball	Roulement à billes	Cojinete de bolas
10	3523098M1			1	Ring, Snap	Anneau d'arrêt	Anillo de resorte
11	6193362M1			1	Disc, Brake	Disque de frein	Disco de freno
12	6193363M1			1	Seal, Ring	Joint, anneau	Junta de anillo
13	6193364M1			1	O-Ring	Joint torique	Junta de tipo O
14	6193365M1			1	Washer	Rondelle	Arandela



820 860 880
 TX760B TX860B
 TX870B

803 804 807 808 813 814 815 816 817 841 842 843 844 845

37004C03.1

6199042M3

1

Jan-06

Rear Axle
Essieu Arrière
Eje trasero

2 Wheel Steer
2 Roues Directrices
Dirección en 2 ruedas

C-37004-04.1-A

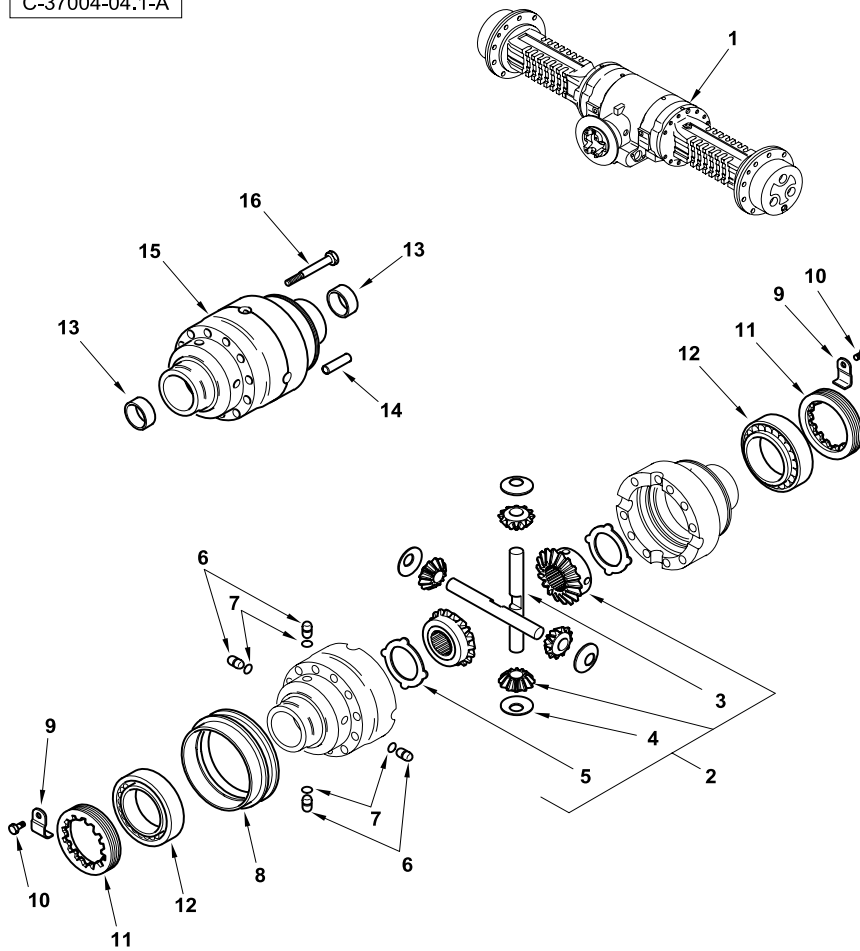

1	6110550M91			1	Axle Assy, Rear	Mont. d'essieu, arrière	Puente trasero, Conj.
2	6193366M91	1		1	Kit, Differential	Jeu, différentiel	Juego, Diferencial
3	6193367M1	2		2	Shaft	Arbre	Árbol
4	6193368M1	2		4	Washer, Thrust	Rondelle de butée	Arandela de tope
5	6193369M1	2		2	Plate	Plaque	Placa
6	6193370M1			4	Pin	Axe	Pasador
7	6193371M1			4	O-Ring	Joint torique	Junta de tipo O
8	6193372M1			1	Sleeve	Chemise	Camisa
9	6193373M1			2	Plate, Locking	Plaque d'arrêt	Placa de bloqueo
10	3523583M1	M6 x 10		2	Screw	Vis	Tornillo
11	6193374M1			2	Nut	Écrou	Tuerca
12	6193375M1			2	Bearing	Coussinet	Cojinete
13	6193376M1			2	Bushing	Bague	Anillo
14	6193377M1	M12 X 40		2	Pin	Axe	Pasador
15	6193378M1			1	Housing	Carter	Cárter
16	6193379M1	M12 x 90		10	Bolt	Boulon	Perno



820 860 880
TX760B TX860B
TX870B

803 804 807 808 813 814 815 816 817 841 842 843 844 845

37004C04.1

6199042M3

1

Jan-06

Rear Axle
Essieu Arrière
Eje trasero

2 Wheel Steer
2 Roues Directrices
Dirección en 2 ruedas

C-37004-05.1-A

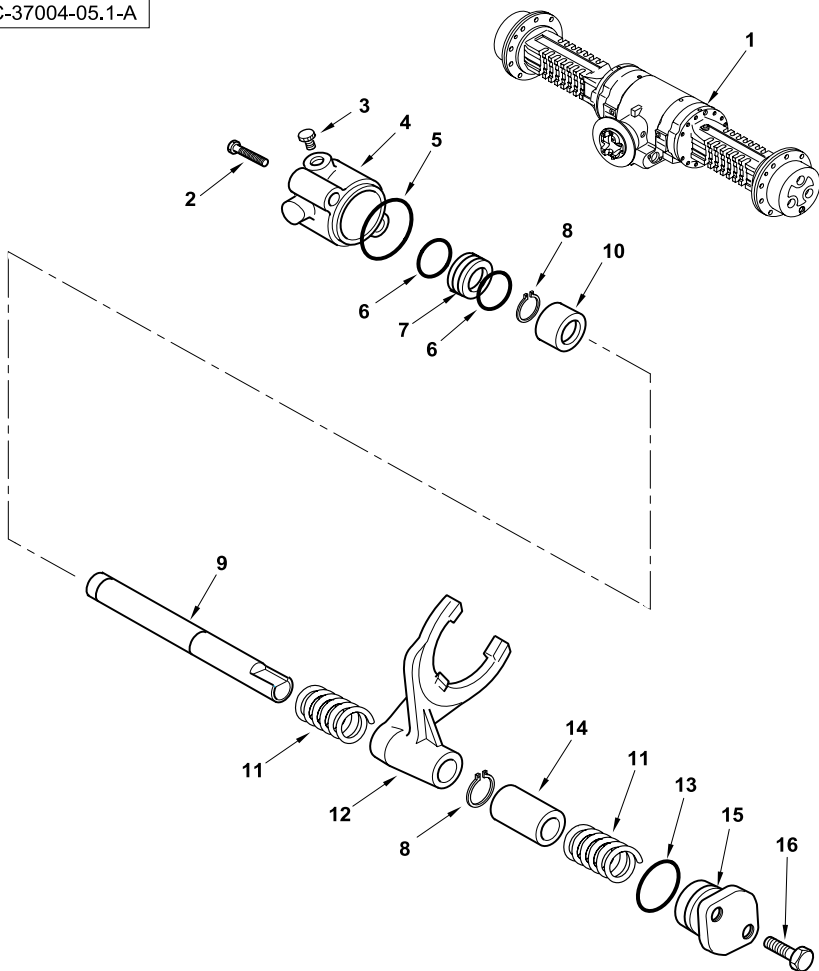

1	6110550M91			1	Axle Assy, Rear	Mont. d'essieu, arrière	Puente trasero, Conj.
2	6193380M1	1	M8 x 80	2	Bolt	Boulon	Perno
3	6193381M1			1	Plug	Bouchon	Tapón
4	6193382M1			1	Support	Support	Soporte
5	6193383M1			1	O-Ring	Joint torique	Junta de tipo O
6	6193384M1			2	O-Ring	Joint torique	Junta de tipo O
7	6193385M1			1	Piston	Piston	Pistón
8	6193386M1			2	Ring, Snap	Anneau d'arrêt	Anillo de resorte
9	6193387M1			1	Shaft	Arbre	Árbol
10	6193388M1			1	Bushing	Bague	Anillo
11	6193389M1			2	Spring	Ressort	Muelle
12	6193390M1			1	Fork	Fourche	Bielda
13	6190278M1			1	O-Ring	Joint torique	Junta de tipo O
14	6193391M1			1	Spacer	Entretoise	Traviesa
15	6193392M1			1	Cover	Cache	Tapa
16	6193393M1		M8 x 30	2	Bolt	Boulon	Perno



820 860 880
TX760B TX860B
TX870B

803 804 807 808 813 814 815 816 817 841 842 843 844 845

37004C05.1

6199042M3

1

Jan-06

Rear Axle
Essieu Arrière
Eje trasero

2 Wheel Steer
2 Roues Directrices
Dirección en 2 ruedas

C-37004-06.1-A

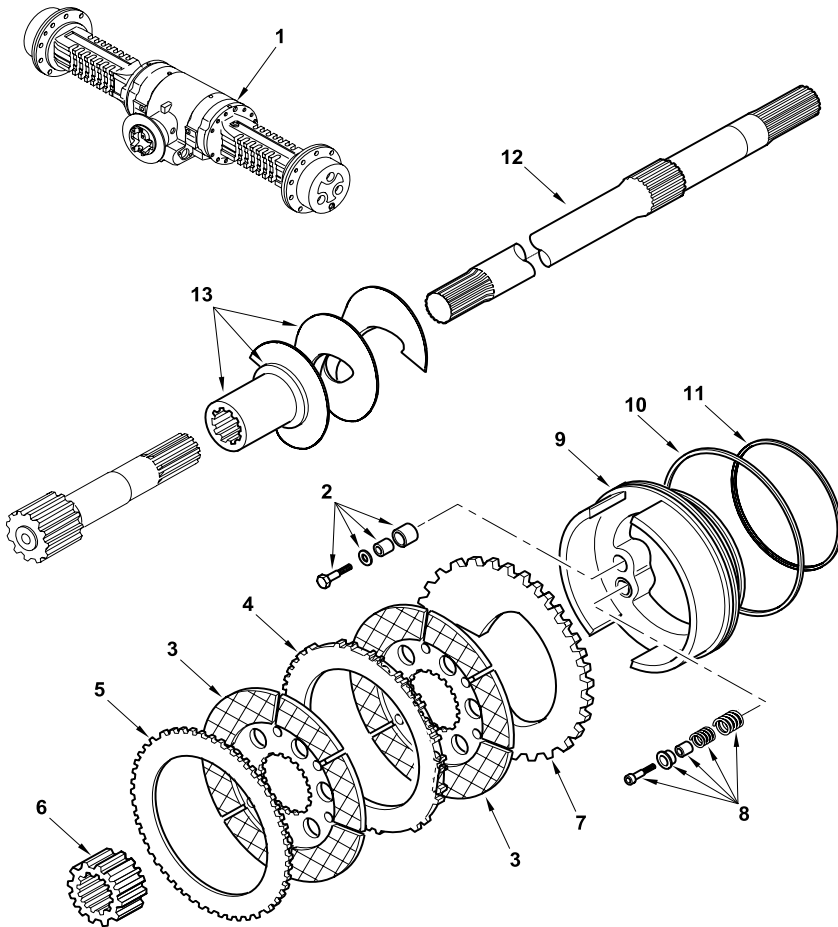

1	6110550M91			1	Axle Assy, Rear	Mont. d'essieu, arrière	Puente trasero, Conj.
2	6193394M1	1		2	Kit, Self Adjuster	Jeu, organe régl. auto.	Juego de autoajuste
3	6193395M1			4	Plate	Plaque	Placa
4	6193396M1			2	Plate	Plaque	Placa
5	6193397M1			2	Plate	Plaque	Placa
6	6193398M1			2	Hub	Moyeu	Cubo
7	6193399M1			2	Plate	Plaque	Placa
8	6193400M91			2	Kit, Self Adjuster	Jeu, organe régl. auto.	Juego de autoajuste
9	6193401M1			2	Piston	Piston	Pistón
10	6193402M1			2	Quadring	Quadring	Quadring
11	6193403M1			2	Quadring	Quadring	Quadring
12	6193404M1			2	Shaft	Arbre	Árbol
13	6193405M1			1	Auger	Tige carrée d'entraîn.	Taladro
13	6193406M1			1	Auger	Tige carrée d'entraîn.	Taladro



820 860 880
TX760B TX860B
TX870B

803 804 807 808 813 814 815 816 817 841 842 843 844 845

37004C06.1

6199042M3

1

Jan-06

Rear Axle
Essieu Arrière
Eje trasero

2 Wheel Steer
2 Roues Directrices
Dirección en 2 ruedas

C-37004-07.1-A

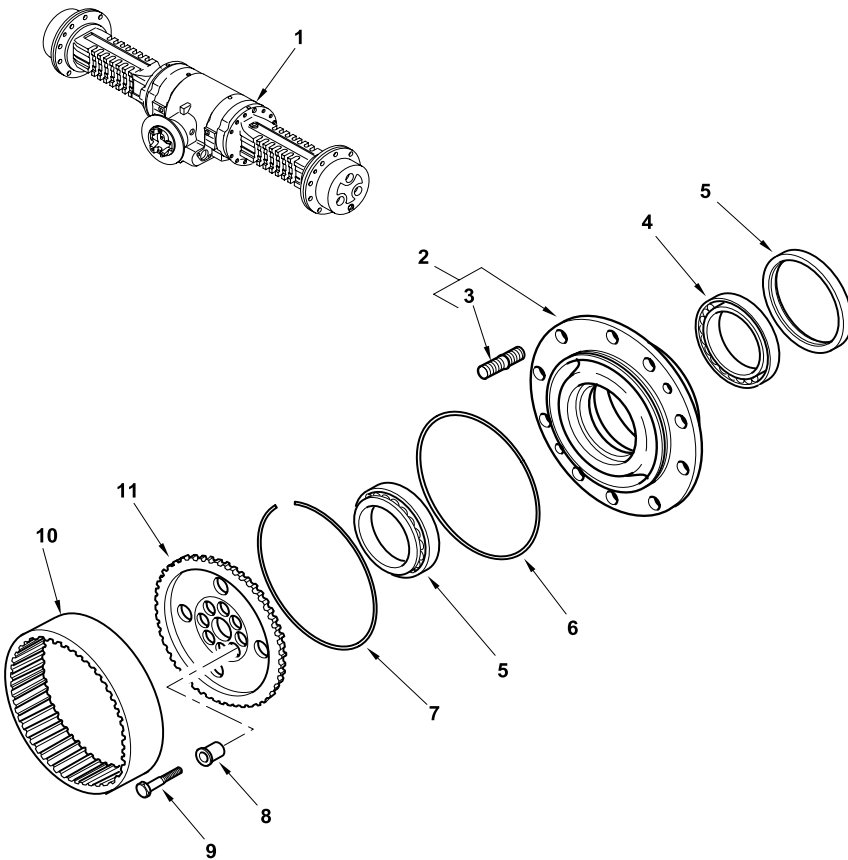

1	6110550M91			1	Axle Assy, Rear	Mont. d'essieu, arrière	Puente trasero, Conj.
2	6194284M91	1		1	Wheel Hub, Assy	Moyen roue, montage	Cubo de rueda, Conj.
3	6190302M1	2		20	Stud	Goujon	Espárrago
4	6193704M1			2	Seal, Ring	Joint, anneau	Junta de anillo
5	3475599M1			4	Bearing, Ball	Roulement à billes	Cojinete de bolas
6	6193409M1			2	O-Ring	Joint torique	Junta de tipo O
7	6193705M1			2	Ring	Anneau	Aro
8	3523272M1		dia 20	16	Bushing	Bague	Anillo
9	3475604M1		M14 x 65	16	Screw	Vis	Tornillo
10	6193410M1			2	Gear	Pignon	Piñón
11	6193411M1			2	Carrier	Support	Portador



820 860 880
TX760B TX860B
TX870B

803 804 807 808 813 814 815 816 817 841 842 843 844 845

37004C07.1

6199042M3

1

Jan-06

Rear Axle
Essieu Arrière
Eje trasero

2 Wheel Steer
2 Roues Directrices
Dirección en 2 ruedas

C-37004-08.1-A

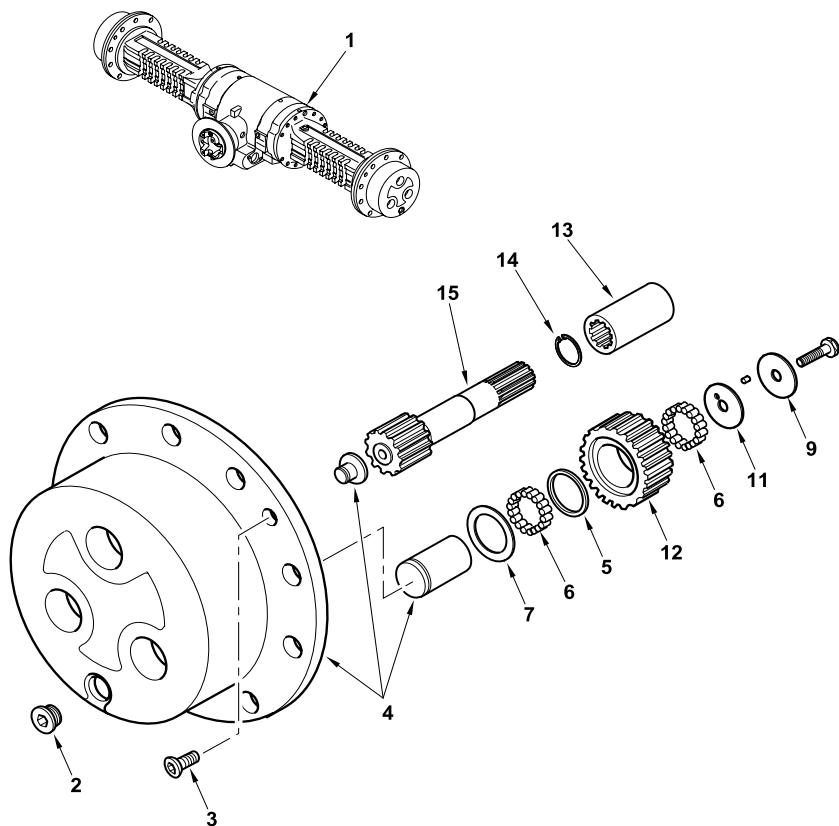

1	6110550M91			1	Axle Assy, Rear	Mont. d'essieu, arrière	Puente trasero, Conj.
2	3523632M1	1	M30 x 2	2	Plug	Bouchon	Tapón
3	6190282M1		M8 x 20	4	Screw	Vis	Tornillo
4	6193412M91			2	Carrier	Support	Portador
5	6193413M1			6	Washer	Rondelle	Arandela
6	6193414M1			37. 2	Needle	Aiguille	Aguja
7	6193415M1			6	Washer, Thrust	Rondelle de butée	Arandela de tope
8	6190283M1		M10 x 50	6	Screw	Vis	Tornillo
9	6193416M1			6	Washer, Thrust	Rondelle de butée	Arandela de tope
10	6193417M1			0.6	Needle	Aiguille	Aguja
11	6193418M1			6	Washer, Thrust	Rondelle de butée	Arandela de tope
12	6193419M1			6	Gear	Pignon	Piñón
13	6193420M1			2	Bushing	Bague	Anillo
14	6193421M1			2	Ring, Snap	Anneau d'arrêt	Anillo de resorte
15	6193422M1			2	Shaft	Arbre	Árbol



820 860 880
 TX760B TX860B
 TX870B

803 804 807 808 813 814 815 816 817 841 842 843 844 845

Rear Axle
Essieu Arrière
Eje trasero

2 Wheel Steer
2 Roues Directrices
Dirección en 2 ruedas

C-37004-09.1-A

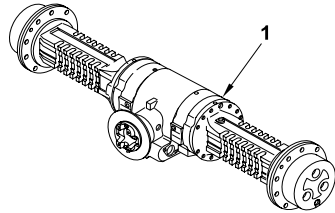

1	6110550M91			1	Axle Assy, Rear	Mont. d'essieu, arrière	Puente trasero, Conj.
2	6193423M91	1		1	Caliper, Brake	Mâchoire, frein	Calibrador de freno
3	6194511M1			1	Flange	Flasque	Brida de unión
4	6194512M1		M12x35	8	Screw	Vis	Tornillo
5	6193426M1			1	Pin	Axe	Pasador
6	6193427M1			1	Bracket	Patte de fixation	Pata de fijación

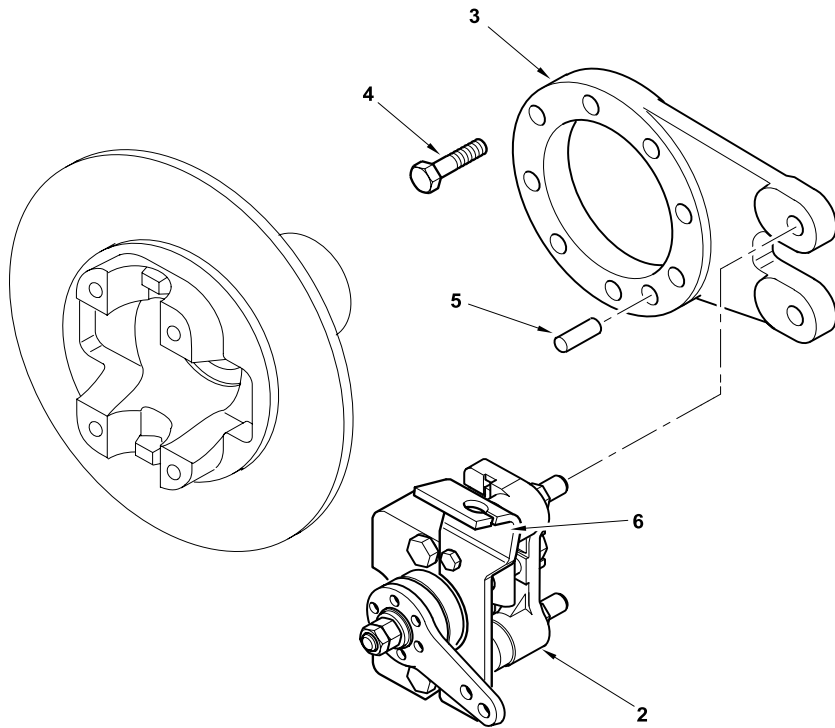

820 860 880
TX760B TX860B
TX870B

803 804 807 808 813 814 815 816 817 841 842 843 844 845

37004C09.1

6199042M3

1

Jan-06

Rear Axle
Essieu Arrière
Eje trasero

Brake Caliper
Mâchoire de Frein
Calibrador de freno

C-37001-07.1-A

1	6109183M91		Continued	1	Axle Assy, Rear	Mont. d'essieu, arrière	Puente trasero, Conj.
2	6193424M1	1		1	Flange	Flasque	Brida de unión
3	6193425M1	1	M12 x 35	8	Bolt	Boulon	Perno
4	6193426M1	1		1	Pin	Axe	Pasador
5	6193427M1	1		1	Bracket	Patte de fixation	Pata de fijación
6	6193423M91	1	👁 37001C08.1 2	1	Caliper, Brake	Mâchoire, frein	Calibrador de freno

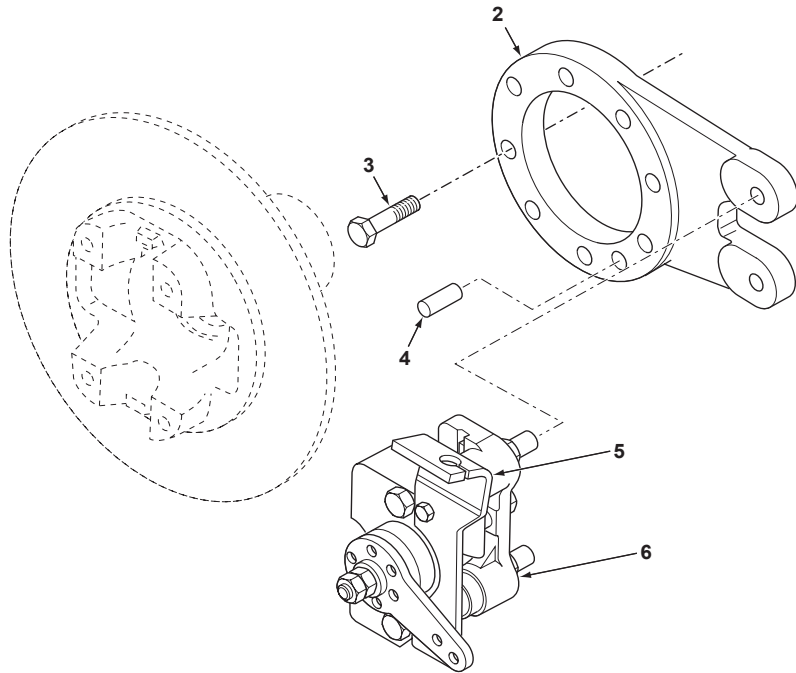

820 860 880
TX760B TX860B
TX870B

801 802 803 804 805 806 807 808 809 810 811 812 813 814 815 816 817 831 832
833 834 841 842 843 844 845

37001C07.1

6199042M3

1

Jan-06

**Rear Axle
Essieu Arrière
Eje trasero**

**Brake Caliper
Mâchoire de Frein
Calibrador de freno**

C-37001-08.1-A

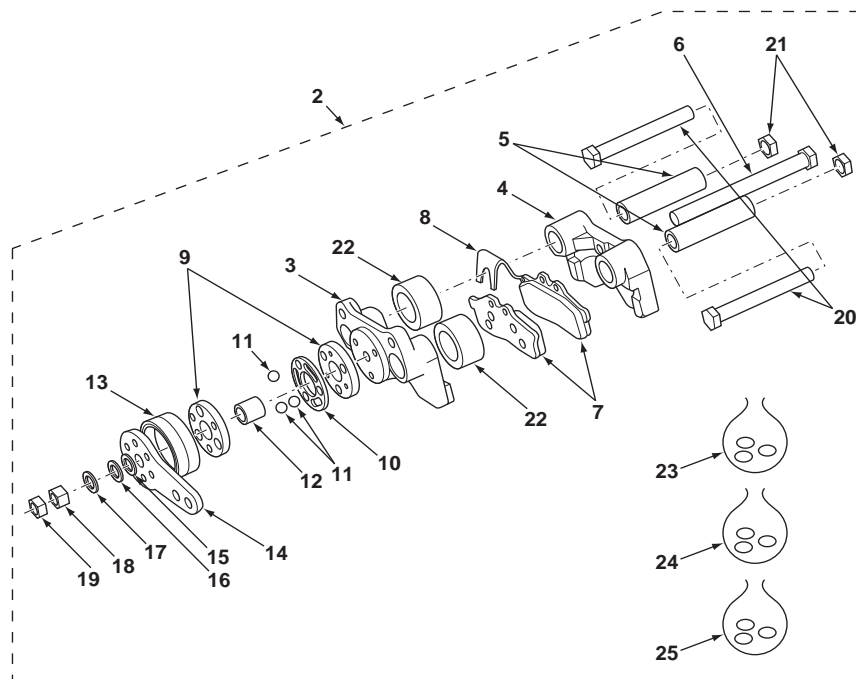

1	6109183M91		Continued	1	Axle Assy, Rear	Mont. d'essieu, arrière	Puente trasero, Conj.
2	6193423M91	1	37001C07.1 6	1	Caliper, Brake	Mâchoire, frein	Calibrador de freno
3		2	Ref. 2	1	Plate	Plaque	Placa
4		2	Ref. 2	1	Plate	Plaque	Placa
5		2 (A)		2	Sleeve	Chemise	Camisa
6		2 (A)		1	Bolt	Boulon	Perno
7		2 (A,E)		2	Lining, Brake	Garniture de friction	Guarnición del freno
8		2 (A,E)		1	Spring	Ressort	Muelle
9		2 (C)		2	Cam	Came	Leva
10		2 (C)		1	Ring	Anneau	Aro
11		2 (C)		3	Bearing, Ball	Roulement à billes	Cojinete de bolas
12		2 (A)		1	Seal	Joint	Junta
13		2 (A)		1	Boot	Soufflet	Fuelle
14	6193747M1	2		1	Lever	Levier	Palanca
15		2 (A)		1	Washer	Rondelle	Arandela
16		2 (A)		1	Washer	Rondelle	Arandela
17		2 (A)		1	Washer	Rondelle	Arandela
18		2 (A)		1	Nut	Écrou	Tuerca
19		2 (A)		1	Nut	Écrou	Tuerca
20		2 (A)		2	Bolt	Boulon	Perno
21		2 (A)		2	Nut	Écrou	Tuerca
22		2 (A)		2	Sleeve	Chemise	Camisa
23	6193748M91	2 (B)	Linings & Hardware	X	Kit, Service	Kit d'entretien	Juego de servicio
24	6193749M91	2 (D)	Cam	X	Kit, Service	Kit d'entretien	Juego de servicio
25	6193750M91	2 (F)	Brake linings	X	Kit, Service	Kit d'entretien	Juego de servicio

- A Included in kit marked (B)
Inclus dans jeu marqué (B)
Incluido en juego marcado (B)
- C Included in kit marked (D)
Inclus dans jeu marqué (D)
Incluido en juego marcado (D)
- E Included in kit marked (F)
Inclus dans jeu marqué (F)
Incluido en juego marcado (F)

- B Contains items marked (A)
Comprend les pièces marquées (A)
Incluye las piezas marcadas (A)
- D Contains items marked (C)
Comprend les pièces marquées (C)
Incluye las piezas marcadas (C)
- F Contains items marked (E)
Comprend les pièces marquées (E)
Incluye las piezas marcadas (E)



820 860 880
TX760B TX860B
TX870B

801 802 803 804 805 806 807 808 809 810 811 812 813 814 815 816 817 831 832
833 834 841 842 843 844 845

37001C08.1

6199042M3

1

Jan-06

Rear Axle
Essieu Arrière
Eje trasero

Brake Caliper
Mâchoire de Frein
Calibrador de freno

C-37002-07.1-A

1	6109184M91		Continued	1	Axle Assy, Rear	Mont. d'essieu, arrière	Puente trasero, Conj.
2	6193424M1	1		1	Flange	Flasque	Brida de unión
3	6193425M1	1	M12 x 35	8	Bolt	Boulon	Perno
4	6193426M1	1		1	Pin	Axe	Pasador
5	6193427M1	1		1	Bracket	Patte de fixation	Pata de fijación
6	6193423M91	1	☉ 37002C08.1 2	1	Caliper, Brake	Mâchoire, frein	Calibrador de freno

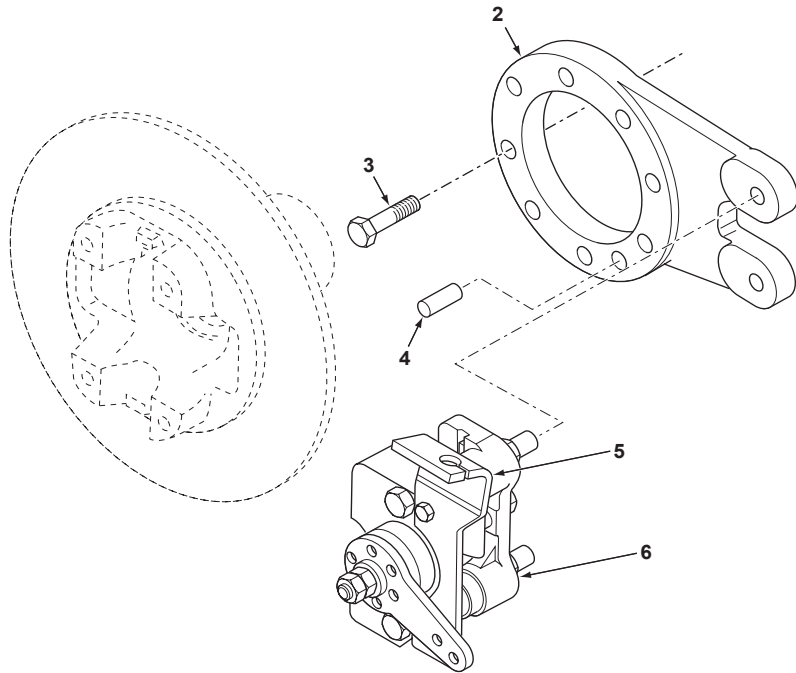

860 880
TX860B TX870B

821 822 823 824 825 851 852 853 854 855

37002C07.1

6199042M3

1

Jan-06

**Rear Axle
Essieu Arrière
Eje trasero**

**Brake Caliper
Mâchoire de Frein
Calibrador de freno**

C-37002-08.1-A

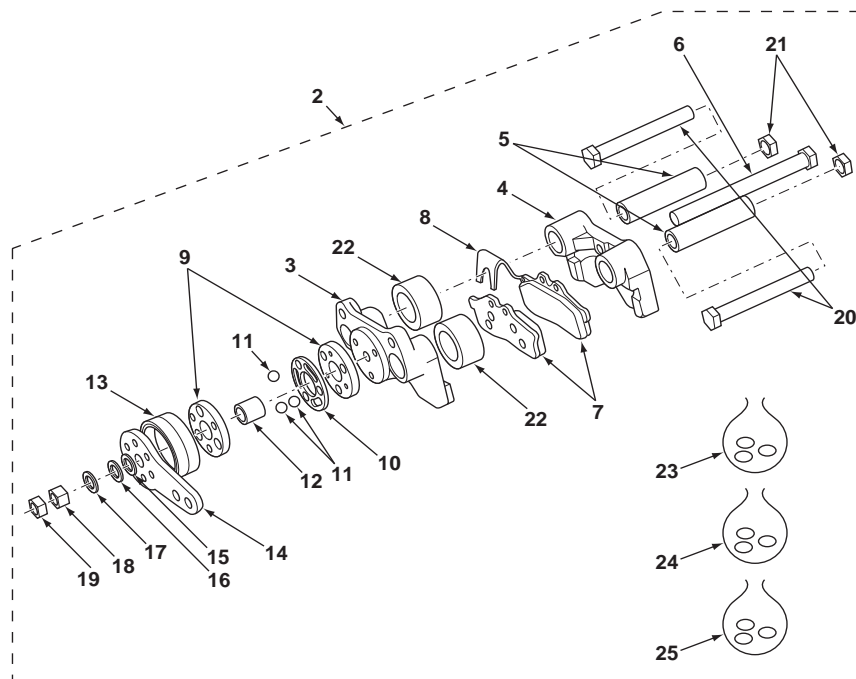

1	6109184M91		Continued	1	Axle Assy, Rear	Mont. d'essieu, arrière	Puente trasero, Conj.
2	6193423M91	1	37002C07.1 6	1	Caliper, Brake	Mâchoire, frein	Calibrador de freno
3		2	Ref. 2	1	Plate	Plaque	Placa
4		2	Ref. 2	1	Plate	Plaque	Placa
5		2 (A)		2	Sleeve	Chemise	Camisa
6		2 (A)		1	Bolt	Boulon	Perno
7		2 (A,E)		2	Lining, Brake	Garniture de friction	Guarnición del freno
8		2 (A,E)		1	Spring	Ressort	Muelle
9		2 (C)		2	Cam	Came	Leva
10		2 (C)		1	Ring	Anneau	Aro
11		2 (C)		3	Bearing, Ball	Roulement à billes	Cojinete de bolas
12		2 (A)		1	Seal	Joint	Junta
13		2 (A)		1	Boot	Soufflet	Fuelle
14	6193747M1	2		1	Lever	Levier	Palanca
15		2 (A)		1	Washer	Rondelle	Arandela
16		2 (A)		1	Washer	Rondelle	Arandela
17		2 (A)		1	Washer	Rondelle	Arandela
18		2 (A)		1	Nut	Écrou	Tuerca
19		2 (A)		1	Nut	Écrou	Tuerca
20		2 (A)		2	Bolt	Boulon	Perno
21		2 (A)		2	Nut	Écrou	Tuerca
22		2 (A)		2	Sleeve	Chemise	Camisa
23	6193748M91	2	(B) Linings & Hardware	X	Kit, Service	Kit d'entretien	Juego de servicio
24	6193749M91	2	(D) Cam	X	Kit, Service	Kit d'entretien	Juego de servicio
25	6193750M91	2	(F) Brake linings	X	Kit, Service	Kit d'entretien	Juego de servicio

- A Included in kit marked (B)
Inclus dans jeu marqué (B)
Incluido en juego marcado (B)
- C Included in kit marked (D)
Inclus dans jeu marqué (D)
Incluido en juego marcado (D)
- E Included in kit marked (F)
Inclus dans jeu marqué (F)
Incluido en juego marcado (F)

- B Contains items marked (A)
Comprend les pièces marquées (A)
Incluye las piezas marcadas (A)
- D Contains items marked (C)
Comprend les pièces marquées (C)
Incluye las piezas marcadas (C)
- F Contains items marked (E)
Comprend les pièces marquées (E)
Incluye las piezas marcadas (E)



860 880
TX860B TX870B

821 822 823 824 825 851 852 853 854 855

Rear Axle
Essieu Arrière
Eje trasero

Brake Caliper
Mâchoire de Frein
Calibrador de freno

4 Wheel Steer
4 Roues Directrices
Dirección en las 4 ruedas

C-37003-08.1-A

1	6109185M91		Continued Ref: 148405	1	Axle Assy, Rear	Mont. d'essieu, arrière	Puente trasero, Conj.
2	6193424M1	1		1	Flange	Flasque	Brida de unión
3	6193425M1	1	M12 x 35	8	Bolt	Boulon	Perno
4	6193426M1	1		1	Pin	Axe	Pasador
5	6193427M1	1		1	Bracket	Patte de fixation	Pata de fijación
6	6194294M91	1	37003C09.1 2	1	Caliper, Brake	Mâchoire, frein	Calibrador de freno
7	6194298M1	1		2	Bolt	Boulon	Perno

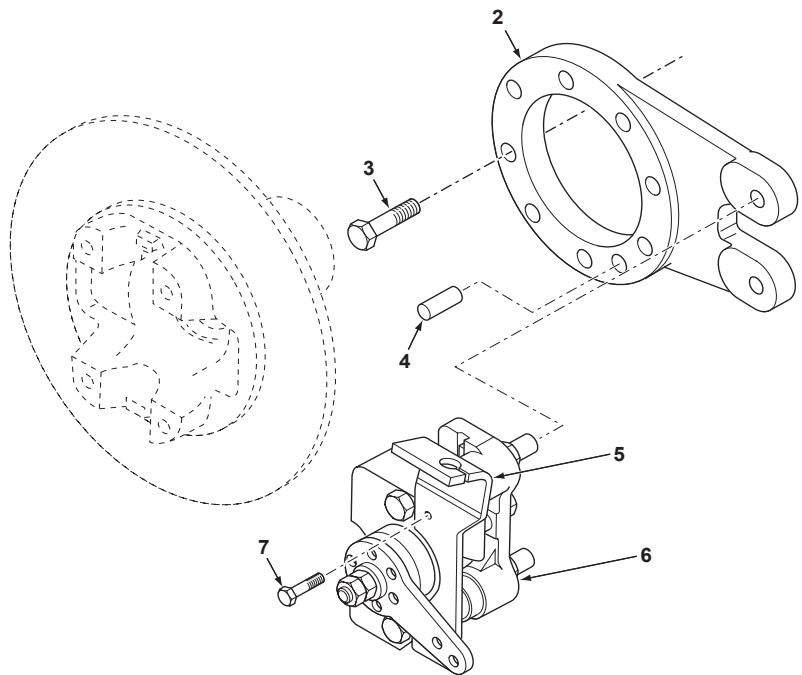

970 980
TX970B

921 922 923 931 932

37003C08.1

6199042M3

1

Jan-06

Rear Axle
Essieu Arrière
Eje trasero

Brake Caliper
Mâchoire de Frein
Calibrador de freno

4 Wheel Steer
4 Roues Directrices
Dirección en las 4 ruedas

C-37003-09.1-A

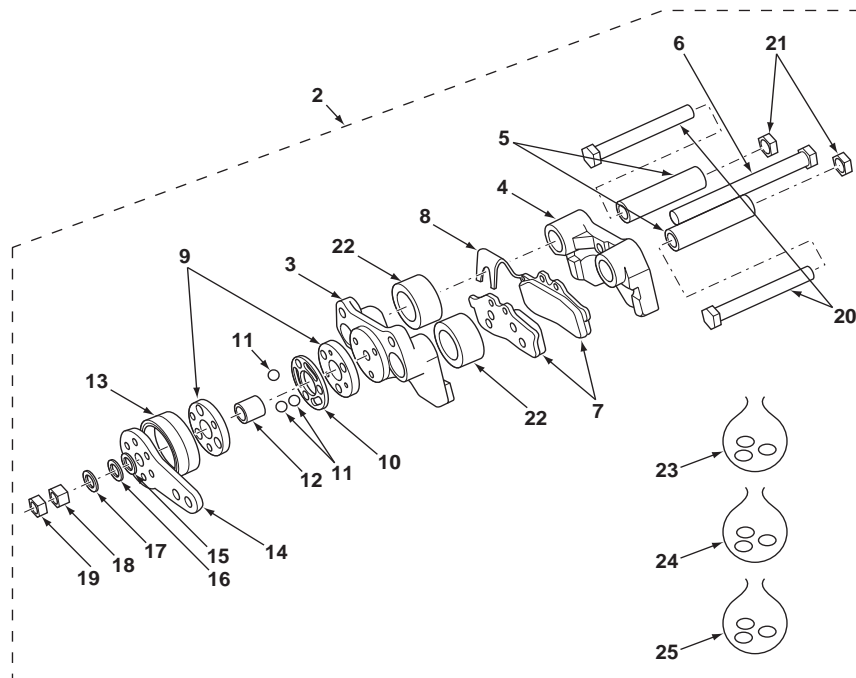

1	6109185M91		Continued Ref: 148405	1	Axle Assy, Rear	Mont. d'essieu, arrière	Puente trasero, Conj.
2	6194294M91	1	37003C08.1 6	1	Caliper, Brake	Mâchoire, frein	Calibrador de freno
3		2	Ref. 2	1	Plate	Plaque	Placa
4		2	Ref. 2	1	Plate	Plaque	Placa
5		2 (A)		2	Sleeve	Chemise	Camisa
6		2 (A)		1	Bolt	Boulon	Perno
7		2 (E)		2	Lining, Brake	Garniture de friction	Guarnición del freno
8		2 (E)		1	Spring	Ressort	Muelle
9		2 (C)		2	Cam	Came	Leva
10		2 (C)		1	Ring	Anneau	Aro
11		2 (C)		3	Bearing, Ball	Roulement à billes	Cojinete de bolas
12		2 (A)		1	Seal	Joint	Junta
13		2 (A)		1	Boot	Soufflet	Fuelle
14		2 (A)		1	Lever	Levier	Palanca
15		2 (A)		1	Washer	Rondelle	Arandela
16		2 (A)		1	Washer	Rondelle	Arandela
17		2 (A)		1	Washer	Rondelle	Arandela
18		2 (A)		1	Nut	Écrou	Tuerca
19		2 (A)		1	Nut	Écrou	Tuerca
20		2 (A)		2	Bolt	Boulon	Perno
21		2 (A)		2	Nut	Écrou	Tuerca
22		2 (A)		2	Sleeve	Chemise	Camisa
23	6194295M91	2	(B) Hardware	X	Kit, Service	Kit d'entretien	Juego de servicio
24	6194296M91	2	(D) Cam	X	Kit, Service	Kit d'entretien	Juego de servicio
25	6194297M91	2	(F) Pad	X	Kit, Service	Kit d'entretien	Juego de servicio

- A Included in kit marked (B)
 Inclus dans jeu marqué (B)
 Includo en juego marcado (B)
- C Included in kit marked (D)
 Inclus dans jeu marqué (D)
 Includo en juego marcado (D)
- E Included in kit marked (F)
 Inclus dans jeu marqué (F)
 Includo en juego marcado (F)

- B Contains items marked (A)
 Comprend les pièces marquées (A)
 Incluye las piezas marcadas (A)
- D Contains items marked (C)
 Comprend les pièces marquées (C)
 Incluye las piezas marcadas (C)
- F Contains items marked (E)
 Comprend les pièces marquées (E)
 Incluye las piezas marcadas (E)



970 980
 TX970B

921 922 923 931 932

37003C09.1

6199042M3

1

Jan-06

Rear Axle
Essieu Arrière - Freins
Eje trasero - Frenos

Brakes
Freins
Frenos

2 Wheel Steer
 2 Roues Directrices
 Dirección en 2 ruedas

C-37001-06.1-A

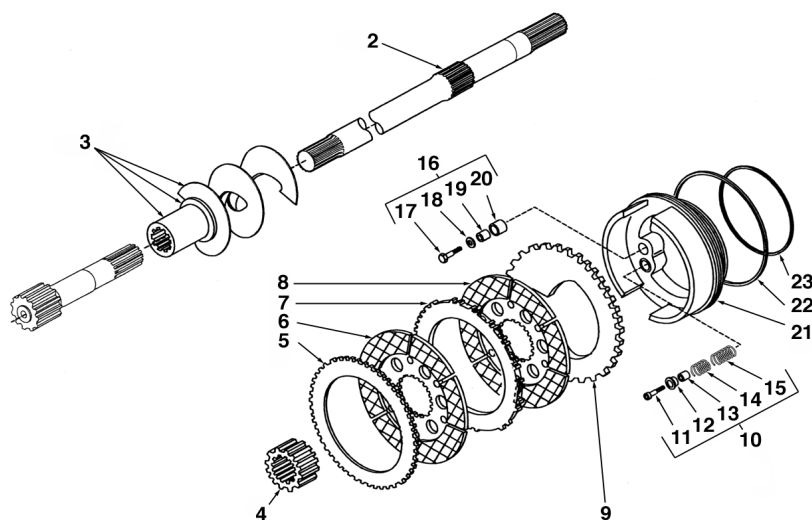

1	6109183M91		Continued	1	Axle Assy, Rear	Mont. d'essieu, arrière	Puente trasero, Conj.
2	6193404M1	1		2	Shaft	Arbre	Árbol
3	6193405M1	1		1	Auger	Tige carrée d'entraîn.	Taladro
3	6193406M1	1	▶	1	Auger	Tige carrée d'entraîn.	Taladro
4	6193398M1	1	▶	2	Hub	Moyeu	Cubo
5	6193397M1	1		2	Plate	Plaque	Placa
6	6193395M1	1		2	Plate	Plaque	Placa
7	6193396M1	1		2	Plate	Plaque	Placa
8	6193395M1	1		2	Plate	Plaque	Placa
9	6193399M1	1		2	Plate	Plaque	Placa
10	6193400M91	1		2	Kit, Self Adjuster	Jeu, organe régl. auto.	Juego de autoajuste
11		10	▶ Ref. 10	3	Bolt	Boulon	Perno
12		10	▶ Ref. 10	3	Cover	Cache	Tapa
13		10	▶ Ref. 10	3	Bushing	Bague	Anillo
14		10	▶ Ref. 10	3	Spring	Ressort	Muelle
15		10	▶ Ref. 10	3	Spring	Ressort	Muelle
16	6193394M91	1		2	Kit, Self Adjuster	Jeu, organe régl. auto.	Juego de autoajuste
17		16	▶ Ref. 16	3	Bolt	Boulon	Perno
18		16	▶ Ref. 16	3	Washer	Rondelle	Arandela
19		16	▶ Ref. 16	3	Bushing	Bague	Anillo
20		16	▶ Ref. 16	3	Pin	Axe	Pasador
21	6193401M1	1		2	Piston	Piston	Pistón
22	6193402M1	1		2	Quadring	Quadring	Quadring
23	6193403M1	1		2	Quadring	Quadring	Quadring



820 860 880
 TX760B TX860B
 TX870B

801 802 803 804 805 806 807 808 809 810 811 812 813 814 815 816 817 831 832
 833 834 841 842 843 844 845

37001C06.1

6199042M3

1

Jan-06

Rear Axle
Essieu Arrière - Freins
Eje trasero - Frenos

Brakes
Freins
Frenos

2 Wheel Steer
 2 Roues Directrices
 Dirección en 2 ruedas

C-37002-06.1-A

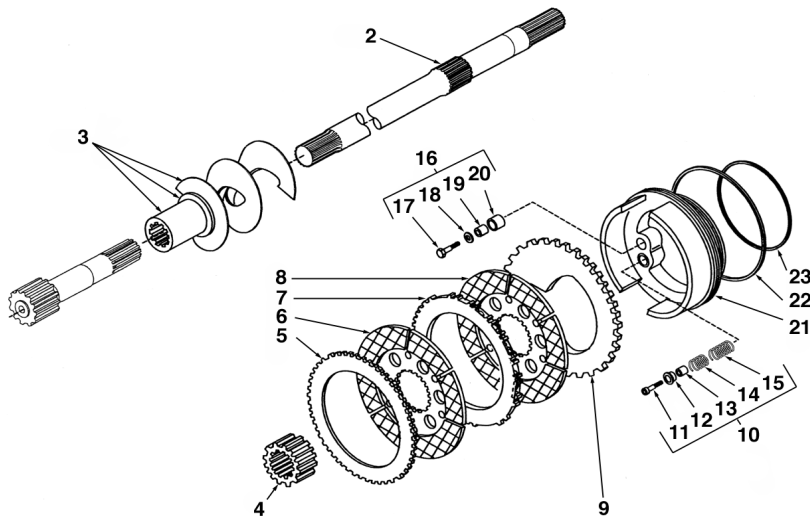

1	6109184M91		Continued	1	Axle Assy, Rear	Mont. d'essieu, arrière	Puente trasero, Conj.
2	6193404M1	1		2	Shaft	Arbre	Árbol
3	6193405M1	1	◀	1	Auger	Tige carrée d'entraîn.	Taladro
3	6193406M1	1	▶	1	Auger	Tige carrée d'entraîn.	Taladro
4	6193398M1	1		2	Hub	Moyeu	Cubo
5	6193397M1	1		2	Plate	Plaque	Placa
6	6193395M1	1		2	Plate	Plaque	Placa
7	6193396M1	1		2	Plate	Plaque	Placa
8	6193395M1	1		2	Plate	Plaque	Placa
9	6193399M1	1		2	Plate	Plaque	Placa
10	6193400M91	1		2	Kit, Self Adjuster	Jeu, organe régl. auto.	Juego de autoajuste
11		10	➤ Ref. 10	3	Bolt	Boulon	Perno
12		10	➤ Ref. 10	3	Cover	Cache	Tapa
13		10	➤ Ref. 10	3	Bushing	Bague	Anillo
14		10	➤ Ref. 10	3	Spring	Ressort	Muelle
15		10	➤ Ref. 10	3	Spring	Ressort	Muelle
16	6193394M91	1		2	Kit, Self Adjuster	Jeu, organe régl. auto.	Juego de autoajuste
17		16	➤ Ref. 16	3	Bolt	Boulon	Perno
18		16	➤ Ref. 16	3	Washer	Rondelle	Arandela
19		16	➤ Ref. 16	3	Bushing	Bague	Anillo
20		16	➤ Ref. 16	3	Pin	Axe	Pasador
21	6193401M1	1		2	Piston	Piston	Pistón
22	6193402M1	1		2	Quadring	Quadring	Quadring
23	6193403M1	1		2	Quadring	Quadring	Quadring



860 880
 TX860B TX870B

821 822 823 824 825 851 852 853 854 855

Rear Axle
Essieu Arrière - Freins
Eje trasero - Frenos

Brakes
Freins
Frenos

4 Wheel Steer
 4 Roues Directrices
 Dirección en las 4 ruedas

C-37003-07.1-A

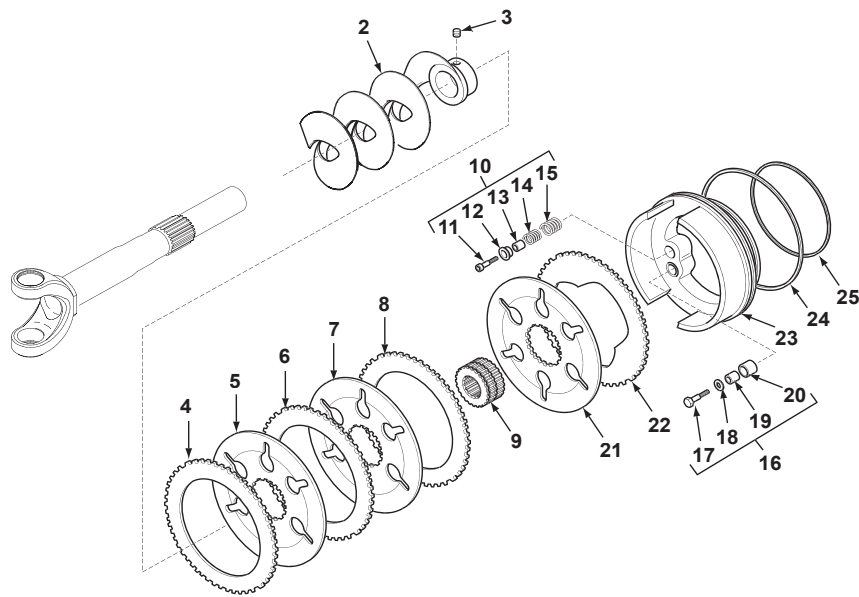

1	6109185M91		Continued Ref: 148405	1	Axle Assy, Rear	Mont. d'essieu, arrière	Puente trasero, Conj.
2	6193702M1	1	▶	1	Auger	Tige carrée d'entraîn.	Taladro
2	6193703M1	1	◀	1	Auger	Tige carrée d'entraîn.	Taladro
3	6193701M1	1	M10 x 10	2	Screw	Vis	Tornillo
4	6193397M1	1		2	Plate	Plaque	Placa
5	6193395M1	1		2	Plate	Plaque	Placa
6	6193397M1	1		2	Plate	Plaque	Placa
7	6193395M1	1		2	Plate	Plaque	Placa
8	6193397M1	1		2	Plate	Plaque	Placa
9	6193700M1	1		2	Hub	Moyeu	Cubo
10	6193400M91	1		2	Kit, Self Adjuster	Jeu, organe régl. auto.	Juego de autoajuste
11		10	▶ Ref. 10	3	Bolt	Boulon	Perno
12		10	▶ Ref. 10	3	Cover	Cache	Tapa
13		10	▶ Ref. 10	3	Bushing	Bague	Anillo
14		10	▶ Ref. 10	3	Spring	Ressort	Muelle
15		10	▶ Ref. 10	3	Spring	Ressort	Muelle
16	6193394M91	1		2	Kit, Self Adjuster	Jeu, organe régl. auto.	Juego de autoajuste
17		16	▶ Ref. 16	3	Bolt	Boulon	Perno
18		16	▶ Ref. 16	3	Washer	Rondelle	Arandela
19		16	▶ Ref. 16	3	Bushing	Bague	Anillo
20		16	▶ Ref. 16	3	Pin	Axe	Pasador
21	6193395M1	1		2	Plate	Plaque	Placa
22	6193399M1	1		2	Plate	Plaque	Placa
23	6193401M1	1		2	Piston	Piston	Pistón
24	6193402M1	1		2	Quadring	Quadring	Quadring
25	6193403M1	1		2	Quadring	Quadring	Quadring



970 980
 TX970B

921 922 923 931 932

37003C07.1

6199042M3

1

Jan-06

Rear Axle
Essieu Arrière
Eje trasero

Centre Housing
Carter Central
Cárter central

2 Wheel Steer
2 Roues Directrices
Dirección en 2 ruedas

C-37001-03.1-A

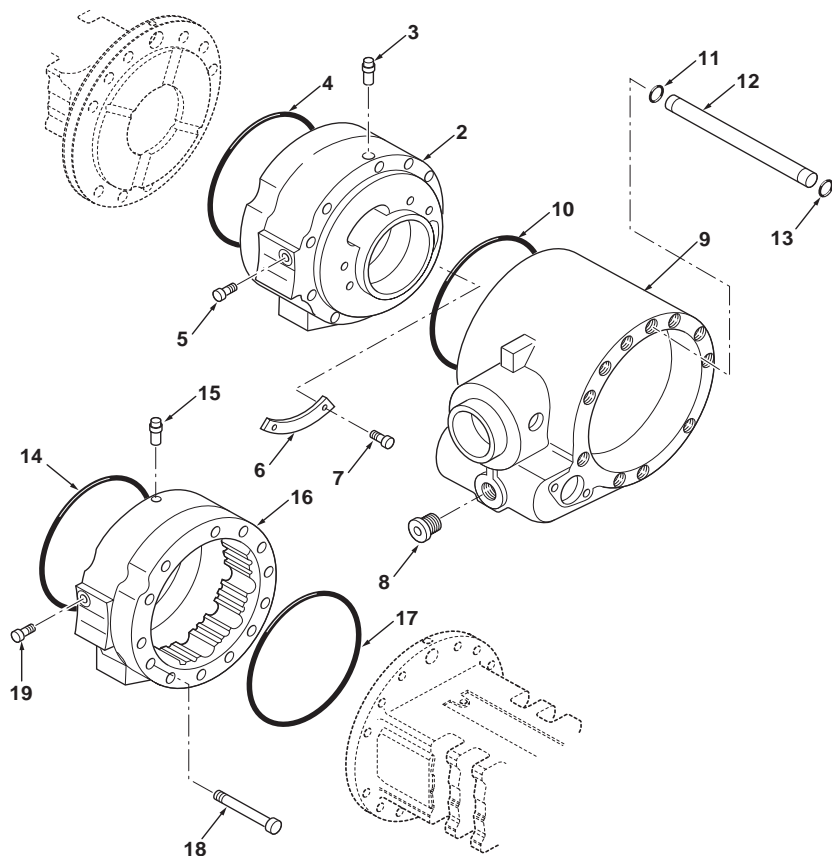

1	6109183M91		Continued	1	Axle Assy, Rear	Mont. d'essieu, arrière	Puente trasero, Conj.
2	6193334M1	1	▶	1	Cylinder, Brake	Cylindre, frein	Pistón de freno
3	6193348M1	1	M10	1	Breather	Reniflard	Ventilador del cárter
4	6193333M1	1		1	O-Ring	Joint torique	Junta de tipo O
5	6193344M1	1		1	Plug	Bouchon	Tapón
6	6193346M1	1		2	Plate	Plaque	Placa
7	6193345M1	1	M4.8 x 6	4	Rivet	Rivet	Remache
8	3523632M1	1	M30 x 2	2	Plug	Bouchon	Tapón
9	6193336M1	1		1	Housing Assy, Center	Ensemble carter centr	Cárter central, Conj.
10	6193333M1	1		1	O-Ring	Joint torique	Junta de tipo O
11	3523630M1	1		1	O-Ring	Joint torique	Junta de tipo O
12	6193335M1	1		1	Pipe	Tuyau	Tubo
13	3523630M1	1		1	O-Ring	Joint torique	Junta de tipo O
14	6193333M1	1		1	O-Ring	Joint torique	Junta de tipo O
15	6193348M1	1	◀ M10	1	Breather	Reniflard	Ventilador del cárter
16	6193337M1	1		1	Cylinder, Brake	Cylindre, frein	Pistón de freno
17	6193333M1	1		1	O-Ring	Joint torique	Junta de tipo O
18	6193343M1	1	M12 x 130	2	Bolt	Boulon	Perno
19	6193344M1	1		1	Plug	Bouchon	Tapón



820 860 880
TX760B TX860B
TX870B

801 802 803 804 805 806 807 808 809 810 811 812 813 814 815 816 817 831 832
833 834 841 842 843 844 845

37001C03.1

6199042M3

1

Jan-06

Rear Axle
Essieu Arrière
Eje trasero

Centre Housing
Carter Central
Cárter central

2 Wheel Steer
2 Roues Directrices
Dirección en 2 ruedas

C-37002-03.1-A

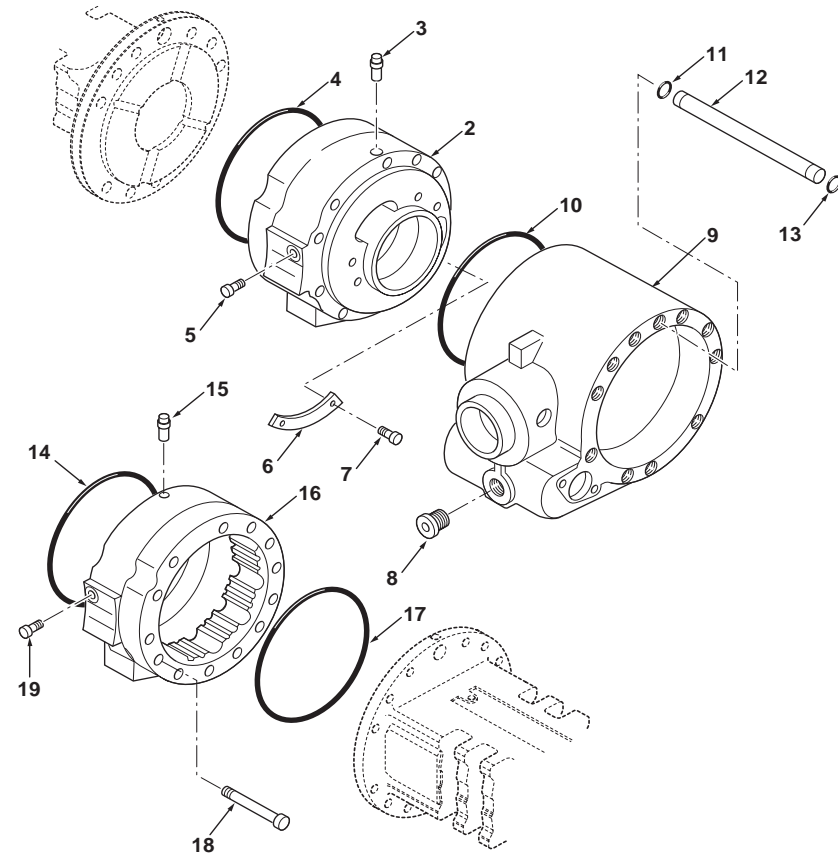

1	6109184M91		Continued	1	Axle Assy, Rear	Mont. d'essieu, arrière	Puente trasero, Conj.
2	6193334M1	1	▶	1	Cylinder, Brake	Cylindre, frein	Pistón de freno
3	6193348M1	1	M10	1	Breather	Reniflard	Ventilador del cárter
4	6193333M1	1		1	O-Ring	Joint torique	Junta de tipo O
5	6193344M1	1		1	Plug	Bouchon	Tapón
6	6193346M1	1		2	Plate	Plaque	Placa
7	6193345M1	1	M4.8 x 6	4	Rivet	Rivet	Remache
8	3523632M1	1	M30 x 2	2	Plug	Bouchon	Tapón
9	6193428M1	1		1	Housing Assy, Center	Ensemble carter centr	Cárter central, Conj.
10	6193333M1	1		1	O-Ring	Joint torique	Junta de tipo O
11	3523630M1	1		1	O-Ring	Joint torique	Junta de tipo O
12	6193335M1	1		1	Pipe	Tuyau	Tubo
13	3523630M1	1		1	O-Ring	Joint torique	Junta de tipo O
14	6193333M1	1		1	O-Ring	Joint torique	Junta de tipo O
15	6193348M1	1	◀ M10	1	Breather	Reniflard	Ventilador del cárter
16	6193337M1	1		1	Cylinder, Brake	Cylindre, frein	Pistón de freno
17	6193333M1	1		1	O-Ring	Joint torique	Junta de tipo O
18	6193343M1	1	M12 x 130	2	Bolt	Boulon	Perno
19	6193344M1	1		1	Plug	Bouchon	Tapón



860 880
TX860B TX870B

821 822 823 824 825 851 852 853 854 855

37002C03.1

6199042M3

1

Jan-06

Rear Axle
Essieu Arrière
Eje trasero

Centre Housing
Carter Central
Cárter central

4 Wheel Steer
4 Roues Directrices
Dirección en las 4 ruedas

C-37003-03.1-A

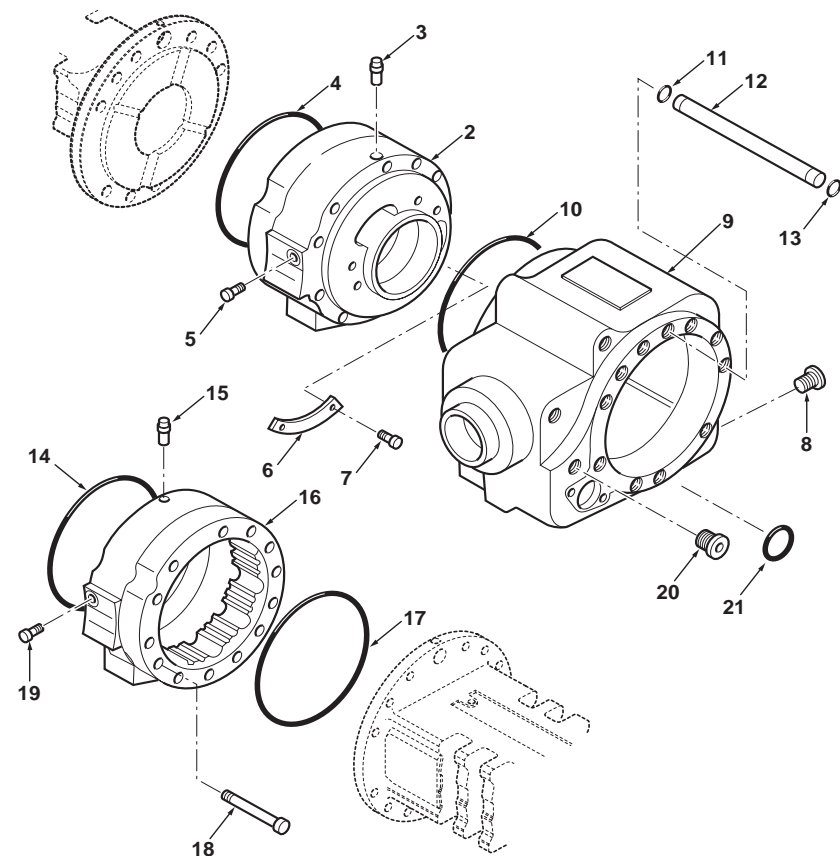

1	6109185M91		Continued Ref: 148405	1	Axle Assy, Rear	Mont. d'essieu, arrière	Puente trasero, Conj.
2	6193334M1	1		1	Cylinder, Brake	Cylindre, frein	Pistón de freno
3	6193348M1	1	M10	1	Breather	Reniflard	Ventilador del cárter
4	6193333M1	1		1	O-Ring	Joint torique	Junta de tipo O
5	6193344M1	1		1	Plug	Bouchon	Tapón
6	6193346M1	1		2	Plate	Plaque	Placa
7	6193345M1	1	M4.8 x 6	4	Rivet	Rivet	Remache
8	3523632M1	1	M30 x 2	2	Plug	Bouchon	Tapón
9	6194289M1	1		1	Housing Assy, Center	Ensemble carter centr	Cárter central, Conj.
10	6193333M1	1		1	O-Ring	Joint torique	Junta de tipo O
11	3523630M1	1		1	O-Ring	Joint torique	Junta de tipo O
12	6193335M1	1		1	Pipe	Tuyau	Tubo
13	3523630M1	1		1	O-Ring	Joint torique	Junta de tipo O
14	6193333M1	1		1	O-Ring	Joint torique	Junta de tipo O
15	6193348M1	1	M10	1	Breather	Reniflard	Ventilador del cárter
16	6193337M1	1		1	Cylinder, Brake	Cylindre, frein	Pistón de freno
17	6193333M1	1		1	O-Ring	Joint torique	Junta de tipo O
18	6193343M1	1	M12 x 130	2	Bolt	Boulon	Perno
19	6193344M1	1		1	Plug	Bouchon	Tapón
20	6193674M1	1		1	Plug	Bouchon	Tapón
21	6193347M1	1		8	O-Ring	Joint torique	Junta de tipo O



970 980
TX970B

921 922 923 931 932

37003C03.1

6199042M3

1

Jan-06

**Rear Axle
Essieu Arrière
Eje trasero**

**Differential
Différentiel
Diferencial**

**Bevel Gear - 2 Wheel Steer
Couple Concique - 2 Roues Directrices
Piñón cónico - dirección en 2 ruedas**

C-37001-09.1-A

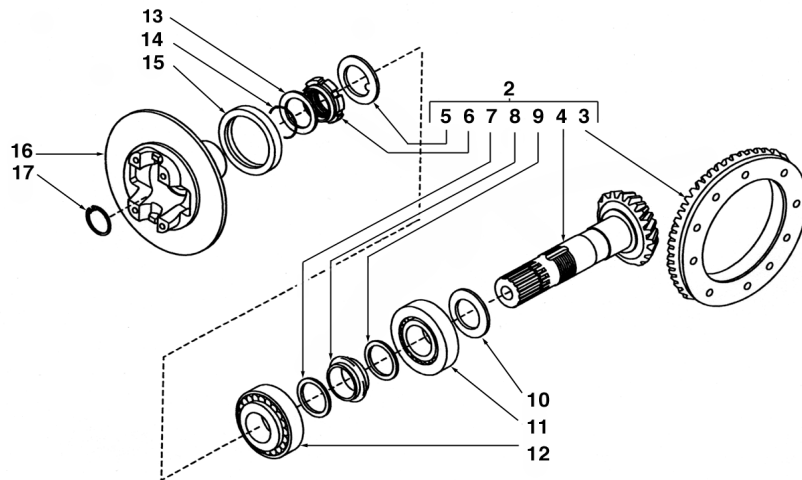

1	6109183M91		Continued	1	Axle Assy, Rear	Mont. d'essieu, arrière	Puente trasero, Conj.
2	6193349M91	2		1	Kit, Crownwheel	Jeu de couronnes	Juego de coronas
3		2	➤ Ref. 2	1	Crownwheel	Couronnes	Corona
4		2	➤ Ref. 2	1	Pinion	Pignon	Piñón
5	3475569M1	2		1	Washer, Lock	Rondelle de blocage	Arandela de freno
6	3475570M1	2	M40	1	Nut	Écrou	Tuerca
7	3523082M1	2		1	Washer	Rondelle	Arandela
8	6193350M1	2		1	Spacer	Entretoise	Traviesa
9	3523082M1	2		1	Washer	Rondelle	Arandela
10	6193351M1	1	2.50 mm	X	Shim	Cale	Calce
10	6193352M1	1	2.60 mm	X	Shim	Cale	Calce
10	6193353M1	1	2.70 mm	X	Shim	Cale	Calce
10	6193354M1	1	2.80 mm	X	Shim	Cale	Calce
10	6193355M1	1	2.90 mm	X	Shim	Cale	Calce
10	6193356M1	1	3.00 mm	X	Shim	Cale	Calce
10	6193357M1	1	3.10 mm	X	Shim	Cale	Calce
10	6193358M1	1	3.20 mm	X	Shim	Cale	Calce
10	6193359M1	1	3.30 mm	X	Shim	Cale	Calce
10	6193360M1	1	3.40 mm	X	Shim	Cale	Calce
11	6193361M1	1		1	Bearing	Coussinet	Cojinete
12	3475567M1	1		1	Bearing, Ball	Roulement à billes	Cojinete de bolas
13	6193365M1	1		1	Washer	Rondelle	Arandela
14	6193364M1	1		1	O-Ring	Joint torique	Junta de tipo O
15	6193363M1	1		1	Seal, Ring	Joint, anneau	Junta de anillo
16	6193362M1	1		1	Disc, Brake	Disque de frein	Disco de freno
17	3523098M1	1		1	Ring, Snap	Anneau d'arrêt	Anillo de resorte



820 860 880
TX760B TX860B
TX870B

801 802 803 804 805 806 807 808 809 810 811 812 813 814 815 816 817 831 832
833 834 841 842 843 844 845

Rear Axle
Essieu Arrière
Eje trasero

Differential
Différentiel
Diferencial

2 Wheel Steer
2 Roues Directrices
Dirección en 2 ruedas

C-37001-10.1-A

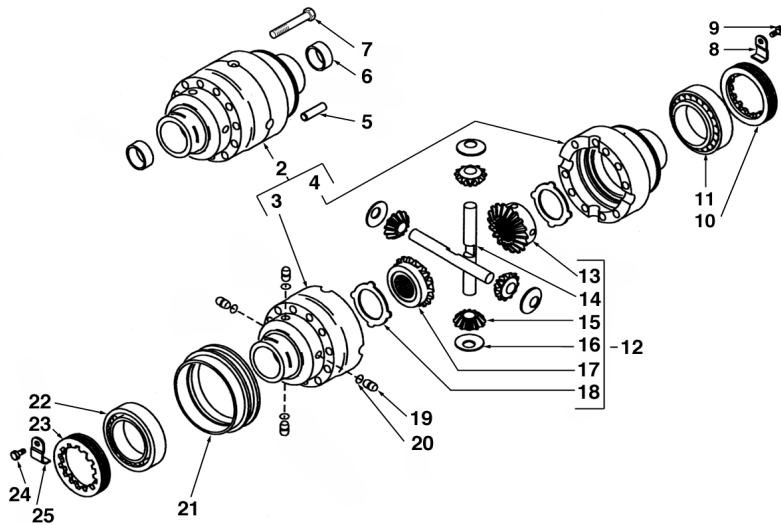

1	6109183M91		Continued	1	Axle Assy, Rear	Mont. d'essieu, arrière	Puente trasero, Conj.
2	6193378M1	1		1	Housing	Carter	Cárter
3		2	➡ Ref. 2	1	Housing	Carter	Cárter
4		2	➡ Ref. 2	1	Housing	Carter	Cárter
5	6193377M1	1	M12 X 40	2	Pin	Axe	Pasador
6	6193376M1	1		2	Bushing	Bague	Anillo
7	6193379M1	1	M12 x 90	10	Bolt	Boulon	Perno
8	6193373M1	1		1	Plate, Locking	Plaque d'arrêt	Placa de bloqueo
9	3523583M1	1	M6 x 10	1	Screw	Vis	Tornillo
10	6193374M1	1		1	Nut	Écrou	Tuerca
11	6193375M1	1		1	Bearing	Coussinet	Cojinete
12	6193366M91	1		1	Kit, Differential	Jeu, différentiel	Juego, Diferencial
13		12	➡ Ref. 12	1	Gear	Pignon	Piñón
14	6193367M1	12		2	Shaft	Arbre	Árbol
15		12	➡ Ref. 12	4	Gear	Pignon	Piñón
16	6193368M1	12		4	Washer, Thrust	Rondelle de butée	Arandela de tope
17		12	➡ Ref. 12	1	Gear	Pignon	Piñón
18	6193369M1	12		2	Plate	Plaque	Placa
19	6193370M1	1		4	Pin	Axe	Pasador
20	6193371M1	1		4	O-Ring	Joint torique	Junta de tipo O
21	6193372M1	1		1	Sleeve	Chemise	Camisa
22	6193375M1	1		1	Bearing	Coussinet	Cojinete
23	6193374M1	1		1	Nut	Écrou	Tuerca
24	3523583M1	1	M6 x 10	1	Screw	Vis	Tornillo
25	6193373M1	1		1	Plate, Locking	Plaque d'arrêt	Placa de bloqueo



820 860 880
TX760B TX860B
TX870B

801 802 803 804 805 806 807 808 809 810 811 812 813 814 815 816 817 831 832
833 834 841 842 843 844 845

37001C10.1

6199042M3

1

Jan-06

**Rear Axle
Essieu Arrière
Eje trasero**

**Differential
Différentiel
Diferencial**

**Bevel Gear
Couple Conrique
Piñón cónico**

C-37002-09.1-A

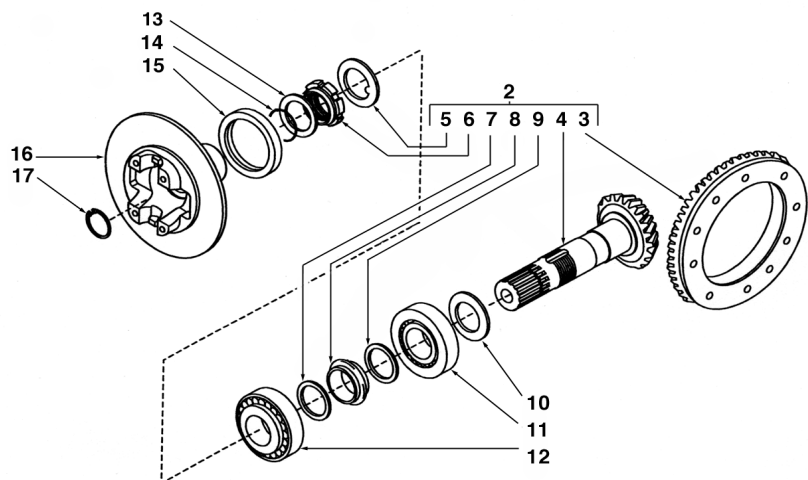

1	6109184M91		Continued	1	Axle Assy, Rear	Mont. d'essieu, arrière	Puente trasero, Conj.
2	6193430M91	1		1	Kit, Crownwheel	Jeu de couronnes	Juego de coronas
3		2	➤ Ref. 2	1	Crownwheel	Couronnes	Corona
4		2	➤ Ref. 2	1	Pinion	Pignon	Piñón
5	3475569M1	2		1	Washer, Lock	Rondelle de blocage	Arandela de freno
6	3475570M1	2	M40	1	Nut	Écrou	Tuerca
7	3523082M1	2		1	Washer	Rondelle	Arandela
8	6193350M1	2		1	Spacer	Entretoise	Traviesa
9	3523082M1	2		1	Washer	Rondelle	Arandela
10	6193351M1	1	2.50 mm	X	Shim	Cale	Calce
10	6193352M1	1	2.60 mm	X	Shim	Cale	Calce
10	6193353M1	1	2.70 mm	X	Shim	Cale	Calce
10	6193354M1	1	2.80 mm	X	Shim	Cale	Calce
10	6193355M1	1	2.90 mm	X	Shim	Cale	Calce
10	6193356M1	1	3.00 mm	X	Shim	Cale	Calce
10	6193357M1	1	3.10 mm	X	Shim	Cale	Calce
10	6193358M1	1	3.20 mm	X	Shim	Cale	Calce
10	6193359M1	1	3.30 mm	X	Shim	Cale	Calce
10	6193360M1	1	3.40 mm	X	Shim	Cale	Calce
11	6193361M1	1		1	Bearing	Coussinet	Cojinete
12	3475567M1	1		1	Bearing, Ball	Roulement à billes	Cojinete de bolas
13	6193365M1	1		1	Washer	Rondelle	Arandela
14	6193364M1	1		1	O-Ring	Joint torique	Junta de tipo O
15	6193363M1	1		1	Seal, Ring	Joint, anneau	Junta de anillo
16	6193362M1	1		1	Disc, Brake	Disque de frein	Disco de freno
17	3523098M1	1		1	Ring, Snap	Anneau d'arrêt	Anillo de resorte



860 880
TX860B TX870B

821 822 823 824 825 851 852 853 854 855

Rear Axle
Essieu Arrière
Eje trasero

Differential
Différentiel
Diferencial

2 Wheel Steer
2 Roues Directrices
Dirección en 2 ruedas

C-37002-10.1-A

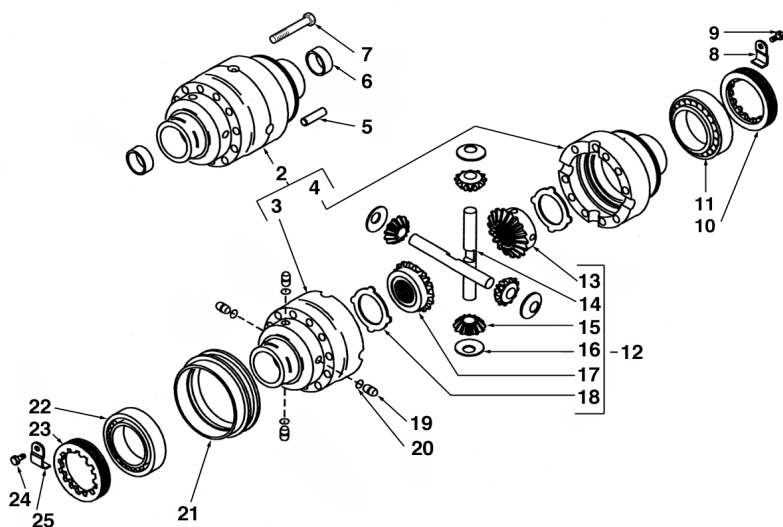

1	6109184M91		Continued	1	Axle Assy, Rear	Mont. d'essieu, arrière	Puente trasero, Conj.
2	6193378M1	1		1	Housing	Carter	Cárter
3		2	➡ Ref. 2	1	Housing	Carter	Cárter
4		2	➡ Ref. 2	1	Housing	Carter	Cárter
5	6193377M1	1	M12 X 40	2	Pin	Axe	Pasador
6	6193376M1	1		2	Bushing	Bague	Anillo
7	6193379M1	1	M12 x 90	10	Bolt	Boulon	Perno
8	6193373M1	1		1	Plate, Locking	Plaque d'arrêt	Placa de bloqueo
9	3523583M1	1	M6 x 10	1	Screw	Vis	Tornillo
10	6193374M1	1		1	Nut	Écrou	Tuerca
11	6193375M1	1		1	Bearing	Coussinet	Cojinete
12	6193366M91	1		1	Kit, Differential	Jeu, différentiel	Juego, Diferencial
13		12	➡ Ref. 12	1	Gear	Pignon	Piñón
14	6193367M1	12		2	Shaft	Arbre	Árbol
15		12	➡ Ref. 12	4	Gear	Pignon	Piñón
16	6193368M1	12		4	Washer, Thrust	Rondelle de butée	Arandela de tope
17		12	➡ Ref. 12	1	Gear	Pignon	Piñón
18	6193369M1	12		2	Plate	Plaque	Placa
19	6193370M1	1		4	Pin	Axe	Pasador
20	6193371M1	1		4	O-Ring	Joint torique	Junta de tipo O
21	6193372M1	1		1	Sleeve	Chemise	Camisa
22	6193375M1	1		1	Bearing	Coussinet	Cojinete
23	6193374M1	1		1	Nut	Écrou	Tuerca
24	3523583M1	1	M6 x 10	1	Screw	Vis	Tornillo
25	6193373M1	1		1	Plate, Locking	Plaque d'arrêt	Placa de bloqueo



860 880
TX860B TX870B

821 822 823 824 825 851 852 853 854 855

37002C10.1

6199042M3

1

Jan-06

Rear Axle
Essieu Arrière
Eje trasero

Differential
Différentiel
Diferencial

Bevel Gear - 4 Wheel Steer
Couple Conique - 4 Roues Directrices
Piñón cónico - dirección en las 4 ruedas

C-37003-11.1-A

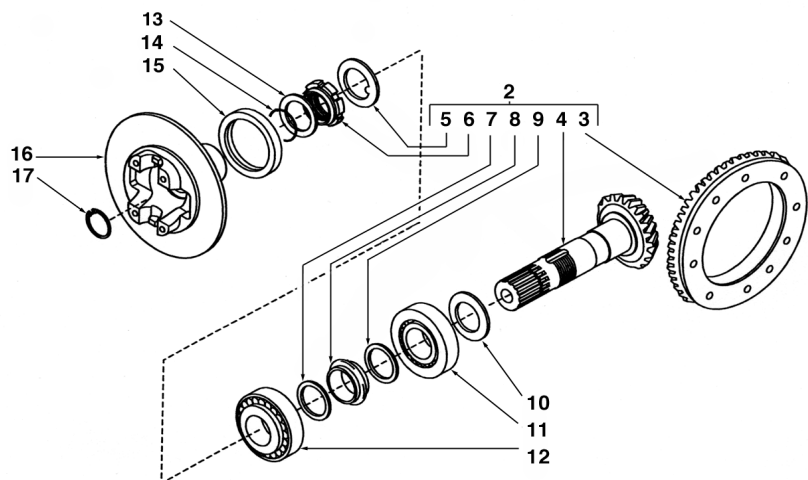

1	6109185M91		Continued Ref: 148405	1	Axle Assy, Rear	Mont. d'essieu, arrière	Puente trasero, Conj.
2	6194292M91	1		1	Gear, Bevel	Couple conique	Par cónico
3		2	➤ Ref. 2	1	Crownwheel	Couronnes	Corona
4		2	➤ Ref. 2	1	Pinion	Pignon	Piñón
5	3475569M1	2		1	Washer, Lock	Rondelle de blocage	Arandela de freno
6	3475570M1	2	M40	1	Nut	Écrou	Tuerca
7	3523082M1	2		1	Washer	Rondelle	Arandela
8	6193350M1	2		1	Spacer	Entretoise	Traviesa
9	3523082M1	2		1	Washer	Rondelle	Arandela
10	6193351M1	1	2.50 mm	X	Shim	Cale	Calce
10	6193352M1	1	2.60 mm	X	Shim	Cale	Calce
10	6193353M1	1	2.70 mm	X	Shim	Cale	Calce
10	6193354M1	1	2.80 mm	X	Shim	Cale	Calce
10	6193355M1	1	2.90 mm	X	Shim	Cale	Calce
10	6193356M1	1	3.00 mm	X	Shim	Cale	Calce
10	6193357M1	1	3.10 mm	X	Shim	Cale	Calce
10	6193358M1	1	3.20 mm	X	Shim	Cale	Calce
10	6193359M1	1	3.30 mm	X	Shim	Cale	Calce
10	6193360M1	1	3.40 mm	X	Shim	Cale	Calce
11	6193361M1	1		1	Bearing	Coussinet	Cojinete
12	3475567M1	1		1	Bearing, Ball	Roulement à billes	Cojinete de bolas
13	6193365M1	1		1	Washer	Rondelle	Arandela
14	6193364M1	1		1	O-Ring	Joint torique	Junta de tipo O
15	6193363M1	1		1	Seal, Ring	Joint, anneau	Junta de anillo
16	6193362M1	1		1	Disc, Brake	Disque de frein	Disco de freno
17	3523098M1	1		1	Ring, Snap	Anneau d'arrêt	Anillo de resorte



970 980
TX970B

921 922 923 931 932

37003C11.1

6199042M3

1

Jan-06

Rear Axle
Essieu Arrière
Eje trasero

Differential
Différentiel
Diferencial

4 Wheel Steer
4 Roues Directrices
Dirección en las 4 ruedas

C-37003-12.1-A

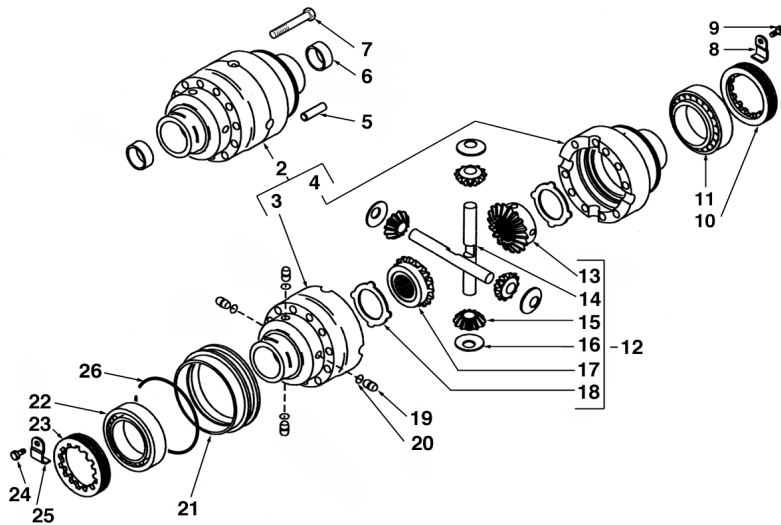

1	6109185M91		Continued Ref: 148405	1	Axle Assy, Rear	Mont. d'essieu, arrière	Puente trasero, Conj.
2	6193378M1	1		1	Housing	Carter	Cárter
3		2	➡ Ref. 2	1	Housing	Carter	Cárter
4		2	➡ Ref. 2	1	Housing	Carter	Cárter
5	6193377M1	1	M12 X 40	2	Pin	Axe	Pasador
6	6193376M1	1		2	Bushing	Bague	Anillo
7	6193379M1	1	M12 x 90	10	Bolt	Boulon	Perno
8	6193373M1	1		1	Plate, Locking	Plaque d'arrêt	Placa de bloqueo
9	3523583M1	1	M6 x 10	1	Screw	Vis	Tornillo
10	6193374M1	1		1	Nut	Écrou	Tuerca
11	6193375M1	1		1	Bearing	Coussinet	Cojinete
12	6193366M91	1		1	Kit, Differential	Jeu, différentiel	Juego, Diferencial
13		12	➡ Ref. 12	1	Gear	Pignon	Piñón
14	6193367M1	12		2	Shaft	Arbre	Árbol
15		12	➡ Ref. 12	4	Gear	Pignon	Piñón
16	6193368M1	12		4	Washer, Thrust	Rondelle de butée	Arandela de tope
17		12	➡ Ref. 12	1	Gear	Pignon	Piñón
18	6193369M1	12		2	Plate	Plaque	Placa
19	6193370M1	1		4	Pin	Axe	Pasador
20	6193371M1	1		4	O-Ring	Joint torique	Junta de tipo O
21	6193372M1	1		1	Sleeve	Chemise	Camisa
22	6193375M1	1		1	Bearing	Coussinet	Cojinete
23	6193374M1	1		1	Nut	Écrou	Tuerca
24	3523583M1	1	M6 x 10	1	Screw	Vis	Tornillo
25	6193373M1	1		1	Plate, Locking	Plaque d'arrêt	Placa de bloqueo
26	6194293M1	1		1	Ring	Anneau	Aro



970 980
TX970B

921 922 923 931 932

37003C12.1

6199042M3

1

Jan-06

Rear Axle
Essieu Arrière
Eje trasero

Differential Lock Mechanism
Blocage de Différentiel
Bloqueo de diferencial

2 Wheel Steer
2 Roues Directrices
Dirección en 2 ruedas

C-37001-11.1-A

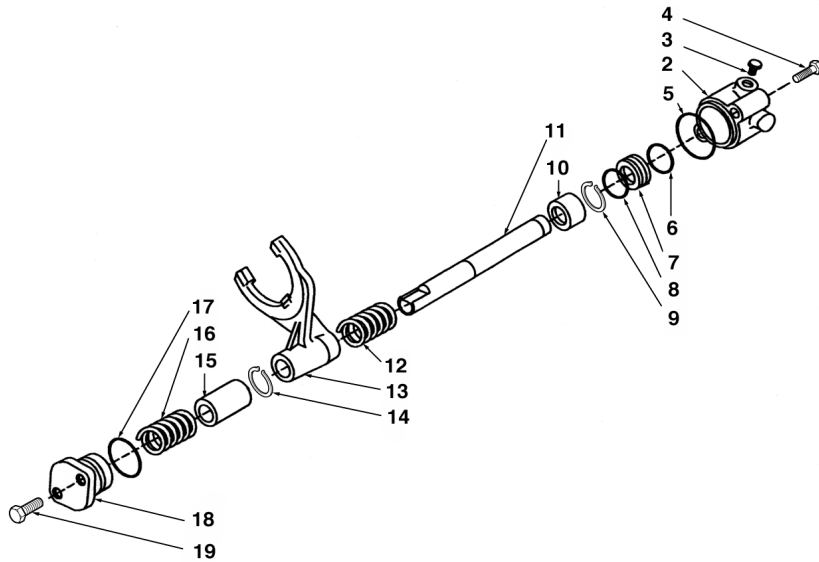

1	6109183M91		Continued	1	Axle Assy, Rear	Mont. d'essieu, arrière	Puente trasero, Conj.
2	6193382M1	1		1	Support	Support	Soporte
3	6193381M1	1		1	Plug	Bouchon	Tapón
4	6193380M1	1	M8 x 80	2	Bolt	Boulon	Perno
5	6193383M1	1		1	O-Ring	Joint torique	Junta de tipo O
6	6193384M1	1		1	O-Ring	Joint torique	Junta de tipo O
7	6193385M1	1		1	Piston	Piston	Pistón
8	6193384M1	1		1	O-Ring	Joint torique	Junta de tipo O
9	6193386M1	1		1	Ring, Snap	Anneau d'arrêt	Anillo de resorte
10	6193388M1	1		1	Bushing	Bague	Anillo
11	6193387M1	1		1	Shaft	Arbre	Árbol
12	6193389M1	1		1	Spring	Ressort	Muelle
13	6193390M1	1		1	Fork	Fourche	Bielda
14	6193386M1	1		1	Ring, Snap	Anneau d'arrêt	Anillo de resorte
15	6193391M1	1		1	Spacer	Entretoise	Traviesa
16	6193389M1	1		1	Spring	Ressort	Muelle
17	6190278M1	1		1	O-Ring	Joint torique	Junta de tipo O
18	6193392M1	1		1	Cover	Cache	Tapa
19	6193393M1	1	M8 x 30	2	Bolt	Boulon	Perno



820 860 880
TX760B TX860B
TX870B

801 802 803 804 805 806 807 808 809 810 811 812 813 814 815 816 817 831 832
833 834 841 842 843 844 845

37001C11.1

6199042M3

1

Jan-06

Rear Axle
Essieu Arrière
Eje trasero

Differential Lock Mechanism
Blocage de Différentiel
Bloqueo de diferencial

2 Wheel Steer
2 Roues Directrices
Dirección en 2 ruedas

C-37002-11.1-A

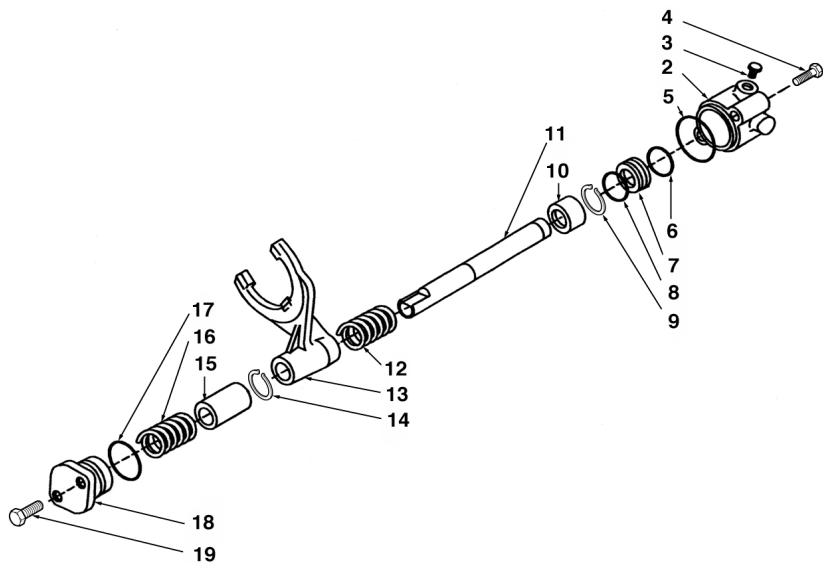

1	6109184M91		Continued	1	Axle Assy, Rear	Mont. d'essieu, arrière	Puente trasero, Conj.
2	6193382M1	1		1	Support	Support	Soporte
3	6193381M1	1		1	Plug	Bouchon	Tapón
4	6193380M1	1	M8 x 80	2	Bolt	Boulon	Perno
5	6193383M1	1		1	O-Ring	Joint torique	Junta de tipo O
6	6193384M1	1		1	O-Ring	Joint torique	Junta de tipo O
7	6193385M1	1		1	Piston	Piston	Pistón
8	6193384M1	1		1	O-Ring	Joint torique	Junta de tipo O
9	6193386M1	1		1	Ring, Snap	Anneau d'arrêt	Anillo de resorte
10	6193388M1	1		1	Bushing	Bague	Anillo
11	6193387M1	1		1	Shaft	Arbre	Árbol
12	6193389M1	1		1	Spring	Ressort	Muelle
13	6193692M1	1		1	Fork	Fourche	Bielda
14	6193386M1	1		1	Ring, Snap	Anneau d'arrêt	Anillo de resorte
15	6193391M1	1		1	Spacer	Entretoise	Traviesa
16	6193389M1	1		1	Spring	Ressort	Muelle
17	6190278M1	1		1	O-Ring	Joint torique	Junta de tipo O
18	6193392M1	1		1	Cover	Cache	Tapa
19	6193393M1	1	M8 x 30	2	Bolt	Boulon	Perno



860 880
TX860B TX870B

821 822 823 824 825 851 852 853 854 855

37002C11.1

6199042M3

1

Jan-06

Rear Axle
Essieu Arrière
Eje trasero

Differential Lock Mechanism
Blocage de Différentiel
Bloqueo de diferencial

4 Wheel Steer
4 Roues Directrices
Dirección en las 4 ruedas

C-37003-13.1-A

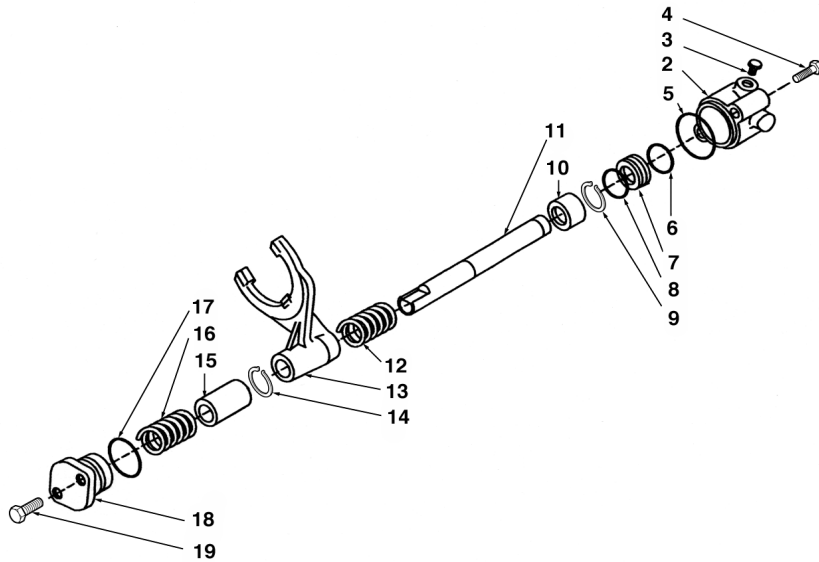

1	6109185M91		Continued Ref: 148405	1	Axle Assy, Rear	Mont. d'essieu, arrière	Puente trasero, Conj.
2	6193691M1	1		1	Support	Support	Soporte
3	6193381M1	1		1	Plug	Bouchon	Tapón
4	6193380M1	1	M8 x 80	2	Bolt	Boulon	Perno
5	6193383M1	1		1	O-Ring	Joint torique	Junta de tipo O
6	6193384M1	1		1	O-Ring	Joint torique	Junta de tipo O
7	6193385M1	1		1	Piston	Piston	Pistón
8	6193384M1	1		1	O-Ring	Joint torique	Junta de tipo O
9	6193386M1	1		1	Ring, Snap	Anneau d'arrêt	Anillo de resorte
10	6193388M1	1		1	Bushing	Bague	Anillo
11	6193387M1	1		1	Shaft	Arbre	Árbol
12	6193389M1	1		1	Spring	Ressort	Muelle
13	6193390M1	1		1	Fork	Fourche	Bielda
14	6193386M1	1		1	Ring, Snap	Anneau d'arrêt	Anillo de resorte
15	6193391M1	1		1	Spacer	Entretoise	Traviesa
16	6193389M1	1		1	Spring	Ressort	Muelle
17	6190278M1	1		1	O-Ring	Joint torique	Junta de tipo O
18	6193392M1	1		1	Cover	Cache	Tapa
19	6193393M1	1	M8 x 30	2	Bolt	Boulon	Perno



970 980
TX970B

921 922 923 931 932

37003C13.1

6199042M3

1

Jan-06

Rear Axle
Essieu Arrière
Eje trasero

Drive Shaft
Arbre d'entraînement
Árbol de arrastre

4 Wheel Steer
4 Roues Directrices
Dirección en las 4 ruedas

C-37003-10.1-A

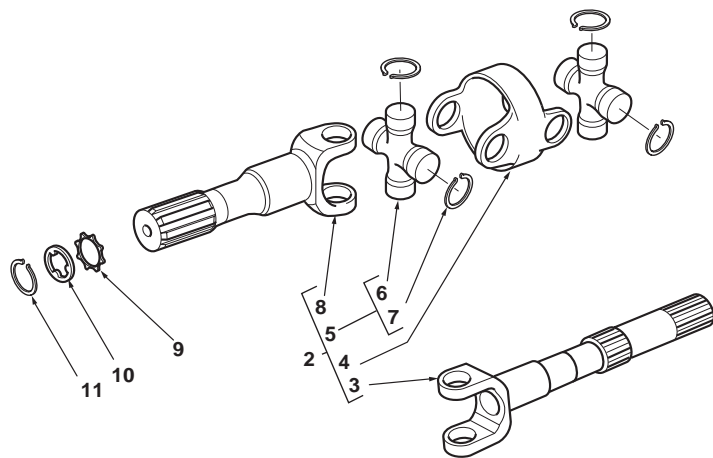

1	6109185M91		Continued Ref: 148405	1	Axle Assy, Rear	Mont. d'essieu, arrière	Puente trasero, Conj.
2	6193693M91	1		2	Joint, Double	Joint, double	Articulación doble
3	6193694M1	2		2	Shaft	Arbre	Árbol
4	6193695M1	2		2	Yoke, Universal Joint	Chape de cardan	Yugo de cardán
5	6193696M1	2		4	Spider Assy	Ensemble croisillon	Cruceta, Conj.
6		5	Ref. 5	4	Spider	Croisillon	Cruceta
7	6193697M1	5		16	Ring	Anneau	Aro
8	6193698M1	2		2	Shaft	Arbre	Árbol
9	6194283M1	1		2	Washer, Thrust	Rondelle de butée	Arandela de tope
10	6193438M1	1		1	Washer	Rondelle	Arandela
11	6193699M1	1		1	Ring, Snap	Anneau d'arrêt	Anillo de resorte



970 980
TX970B

921 922 923 931 932

37003C10.1

6199042M3

1

Jan-06

Rear Axle
Essieu Arrière
Eje trasero

Epicyclic Reduction Gear
Train Epicycloïdal
Reductor epicíclico

2 Wheel Steer
2 Roues Directrices
Dirección en 2 ruedas

C-37001-05.1-A

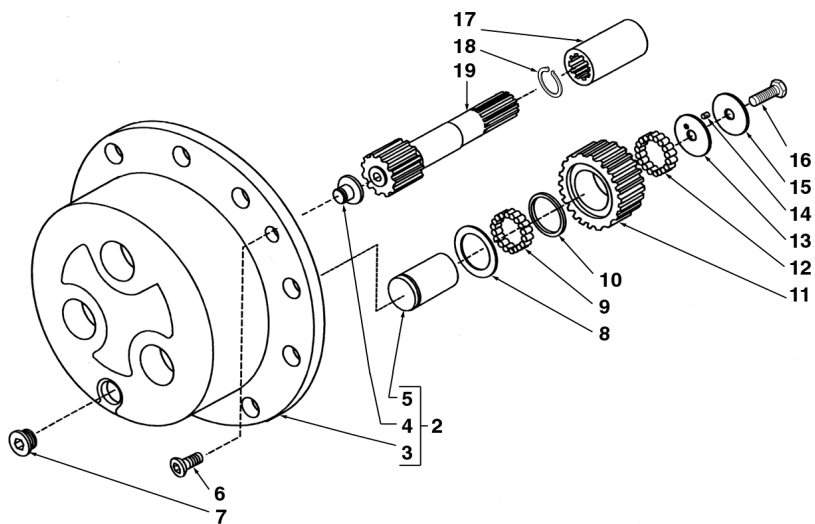

1	6109183M91		Continued	1	Axle Assy, Rear	Mont. d'essieu, arrière	Puente trasero, Conj.
2	6193412M91	1		2	Carrier	Support	Portador
3		2	▶ Ref. 2	1	Carrier	Support	Portador
4		2	▶ Ref. 2	1	Pad	Plaque antidérapante	Cinta antideslizante
5		2	▶ Ref. 2	3	Shaft	Arbre	Árbol
6	6190282M1	1	M8 x 20	4	Screw	Vis	Tornillo
7	3523632M1	1	M30 x 2	2	Plug	Bouchon	Tapón
8	6193415M1	1		6	Washer, Thrust	Rondelle de butée	Arandela de tope
9	6193414M1	1		18	Needle	Aiguille	Aguja
10	6193413M1	1		6	Washer	Rondelle	Arandela
11	6193419M1	1		6	Gear	Pignon	Piñón
12	6193414M1	1		18	Needle	Aiguille	Aguja
13	6193418M1	1		6	Washer, Thrust	Rondelle de butée	Arandela de tope
14	6193417M1	1		6	Needle	Aiguille	Aguja
15	6193416M1	1		6	Washer, Thrust	Rondelle de butée	Arandela de tope
16	6190283M1	1	M10 x 50	6	Screw	Vis	Tornillo
17	6193420M1	1		2	Bushing	Bague	Anillo
18	6193421M1	1		2	Ring, Snap	Anneau d'arrêt	Anillo de resorte
19	6193422M1	1		2	Shaft	Arbre	Árbol



820 860 880
TX760B TX860B
TX870B

801 802 803 804 805 806 807 808 809 810 811 812 813 814 815 816 817 831 832
833 834 841 842 843 844 845

37001C05.1

6199042M3

1

Jan-06

Rear Axle
Essieu Arrière
Eje trasero

Epicyclic Reduction Gear
Train Epicycloïdal
Reductor epicíclico

2 Wheel Steer
2 Roues Directrices
Dirección en 2 ruedas

C-37002-05.1-A

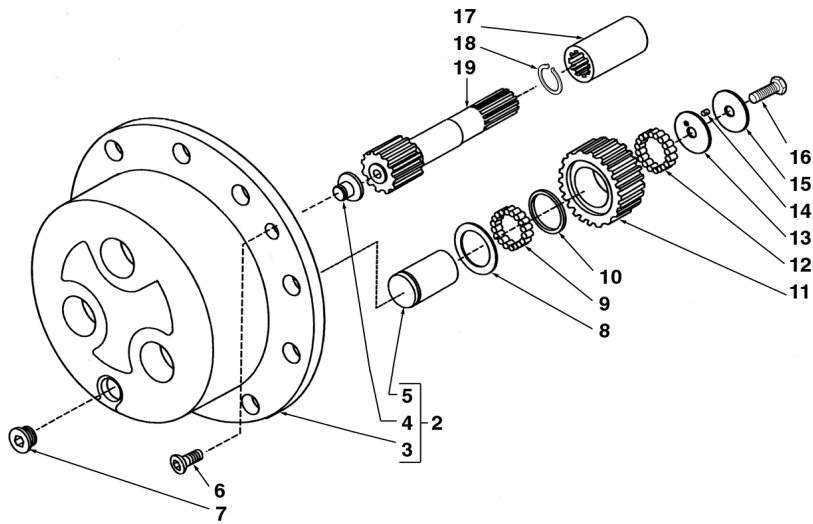

1	6109184M91		Continued	1	Axle Assy, Rear	Mont. d'essieu, arrière	Puente trasero, Conj.
2	6193412M91	1		2	Carrier	Support	Portador
3		2	▶ Ref. 2	1	Carrier	Support	Portador
4		2	▶ Ref. 2	1	Pad	Plaque antidérapante	Cinta antideslizante
5		2	▶ Ref. 2	3	Shaft	Arbre	Árbol
6	6190282M1	1	M8 x 20	4	Screw	Vis	Tornillo
7	3523632M1	1	M30 x 2	2	Plug	Bouchon	Tapón
8	6193415M1	1		6	Washer, Thrust	Rondelle de butée	Arandela de tope
9	6193414M1	1		18	Needle	Aiguille	Aguja
10	6193413M1	1		6	Washer	Rondelle	Arandela
11	6193419M1	1		6	Gear	Pignon	Piñón
12	6193414M1	1		18	Needle	Aiguille	Aguja
13	6193418M1	1		6	Washer, Thrust	Rondelle de butée	Arandela de tope
14	6193417M1	1		6	Needle	Aiguille	Aguja
15	6193416M1	1		6	Washer, Thrust	Rondelle de butée	Arandela de tope
16	6190283M1	1	M10 x 50	6	Screw	Vis	Tornillo
17	6193420M1	1		2	Bushing	Bague	Anillo
18	6193421M1	1		2	Ring, Snap	Anneau d'arrêt	Anillo de resorte
19	6193422M1	1		2	Shaft	Arbre	Árbol



860 880
TX860B TX870B

821 822 823 824 825 851 852 853 854 855

37002C05.1

6199042M3

1

Jan-06

Rear Axle
Essieu Arrière
Eje trasero

Epicyclic Reduction Gear
Train Épicycloïdal
Reductor epicíclico

4 Wheel Steer
4 Roues Directrices
Dirección en las 4 ruedas

C-37003-06.1-A

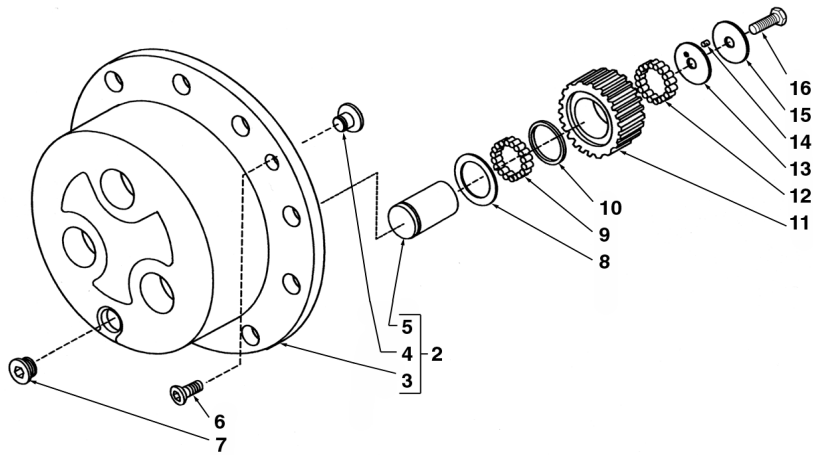

1	6109185M91		Continued Ref: 148405	1	Axle Assy, Rear	Mont. d'essieu, arrière	Puente trasero, Conj.
2	6193412M91	1		2	Carrier	Support	Portador
3		2	▶ Ref. 2	1	Carrier	Support	Portador
4		2	▶ Ref. 2	1	Pad	Plaque antidérapante	Cinta antideslizante
5		2	▶ Ref. 2	3	Shaft	Arbre	Árbol
6	6190282M1	1	M8 x 20	4	Screw	Vis	Tornillo
7	3523632M1	1	M30 x 2	2	Plug	Bouchon	Tapón
8	6193415M1	1		6	Washer, Thrust	Rondelle de butée	Arandela de tope
9	6193414M1	1		18	Needle	Aiguille	Aguja
10	6193413M1	1		6	Washer	Rondelle	Arandela
11	6193419M1	1		6	Gear	Pignon	Piñón
12	6193414M1	1		18	Needle	Aiguille	Aguja
13	6193418M1	1		6	Washer, Thrust	Rondelle de butée	Arandela de tope
14	6193417M1	1		6	Needle	Aiguille	Aguja
15	6193416M1	1		6	Washer, Thrust	Rondelle de butée	Arandela de tope
16	6190283M1	1	M10 x 50	6	Screw	Vis	Tornillo



970 980
TX970B

921 922 923 931 932

37003C06.1

6199042M3

1

Jan-06

Rear Axle
Essieu Arrière
Eje trasero

Housing
Pont Arrière - Carter
Cárter

2 Wheel Steer
2 Roues Directrices
Dirección en 2 ruedas

C-37001-02.1-A

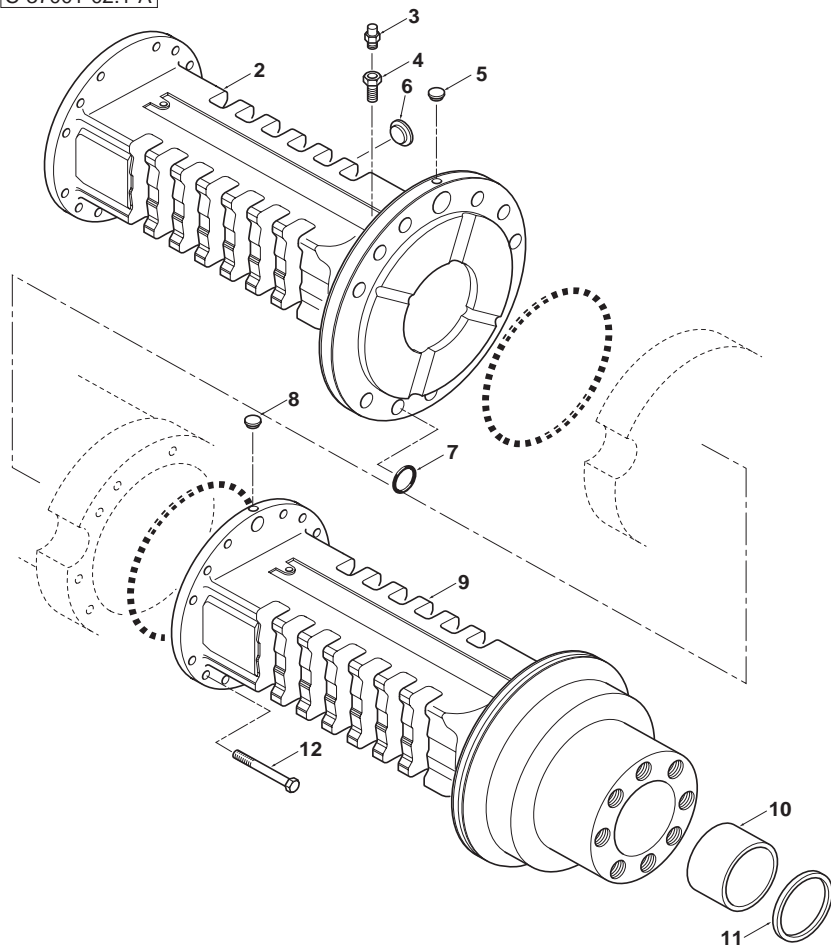

1	6109183M91		Continued	1	Axle Assy, Rear	Mont. d'essieu, arrière	Puente trasero, Conj.
2	6193339M1	1	▶	1	Housing, Axle	Carter de pont	Cárter de puente
3	3475328M1	1	M10	1	Breather	Reniflard	Ventilador del cárter
4	6193338M1	1	Breather	1	Pipe	Tuyau	Tubo
5	3523998M1	1	M10 x 1	1	Plug	Bouchon	Tapón
6	3523632M1	1	M30 x 2	2	Plug	Bouchon	Tapón
7	6193347M1	1		8	O-Ring	Joint torique	Junta de tipo O
8	3523998M1	1	M10 x 1	1	Plug	Bouchon	Tapón
9	6193332M1	1	◀	1	Housing, Axle	Carter de pont	Cárter de puente
10	6193340M1	1		2	Bushing	Bague	Anillo
11	6193341M1	1		2	Seal, Ring	Joint, anneau	Junta de anillo
12	6193342M1	1	M14 x 140	22	Bolt	Boulon	Perno



820 860 880
TX760B TX860B
TX870B

801 802 803 804 805 806 807 808 809 810 811 812 813 814 815 816 817 831 832
833 834 841 842 843 844 845

37001C02.1

6199042M3

1

Jan-06

Rear Axle
Essieu Arrière
Eje trasero

Housing
Pont Arrière - Carter
Cárter

2 Wheel Steer
2 Roues Directrices
Dirección en 2 ruedas

C-37002-02.1-A

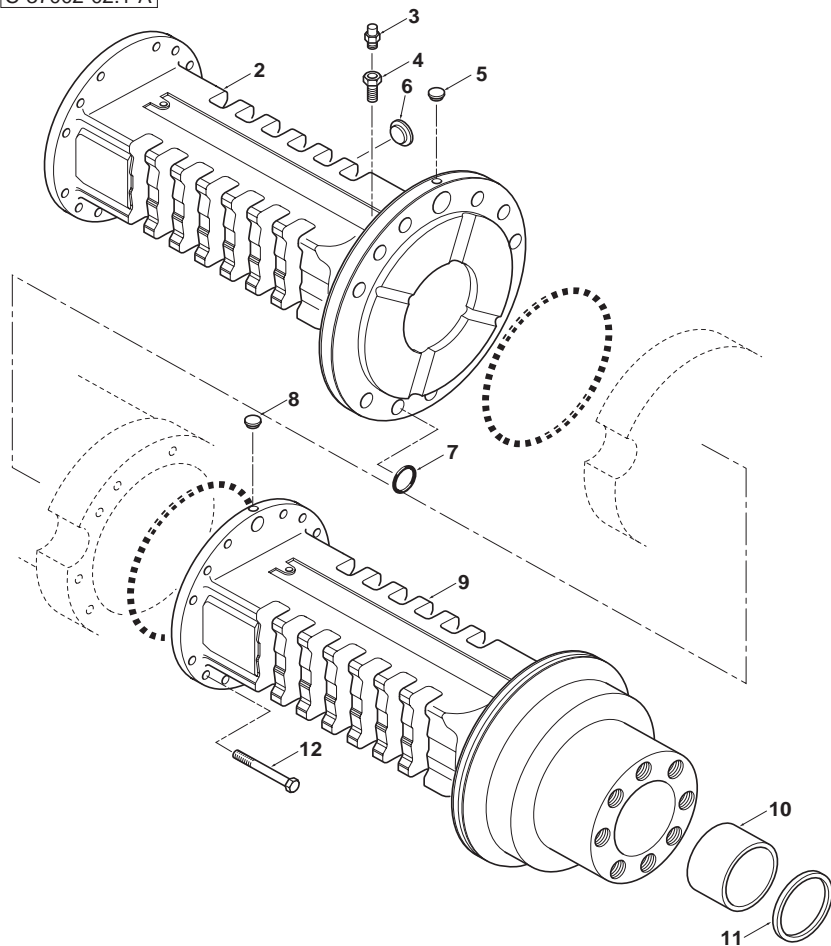

1	6109184M91		Continued	1	Axle Assy, Rear	Mont. d'essieu, arrière	Puente trasero, Conj.
2	6193339M1	1	▶	1	Housing, Axle	Carter de pont	Cárter de puente
3	3475328M1	1	M10	1	Breather	Reniflard	Ventilador del cárter
4	6193338M1	1	Breather	1	Pipe	Tuyau	Tubo
5	3523998M1	1	M10 x 1	1	Plug	Bouchon	Tapón
6	3523632M1	1	M30 x 2	2	Plug	Bouchon	Tapón
7	6193347M1	1		8	O-Ring	Joint torique	Junta de tipo O
8	3523998M1	1	M10 x 1	1	Plug	Bouchon	Tapón
9	6193429M1	1	◀	1	Housing, Axle	Carter de pont	Cárter de puente
10	6193340M1	1		2	Bushing	Bague	Anillo
11	6193341M1	1		2	Seal, Ring	Joint, anneau	Junta de anillo
12	6193342M1	1	M14 x 140	22	Bolt	Boulon	Perno



860 880
TX860B TX870B

821 822 823 824 825 851 852 853 854 855

37002C02.1

6199042M3

1

Jan-06

Rear Axle
Essieu Arrière
Eje trasero

Housing
Pont Arrière - Carter
Cárter

4 Wheel Steer
4 Roues Directrices
Dirección en las 4 ruedas

C-37003-02.1-A

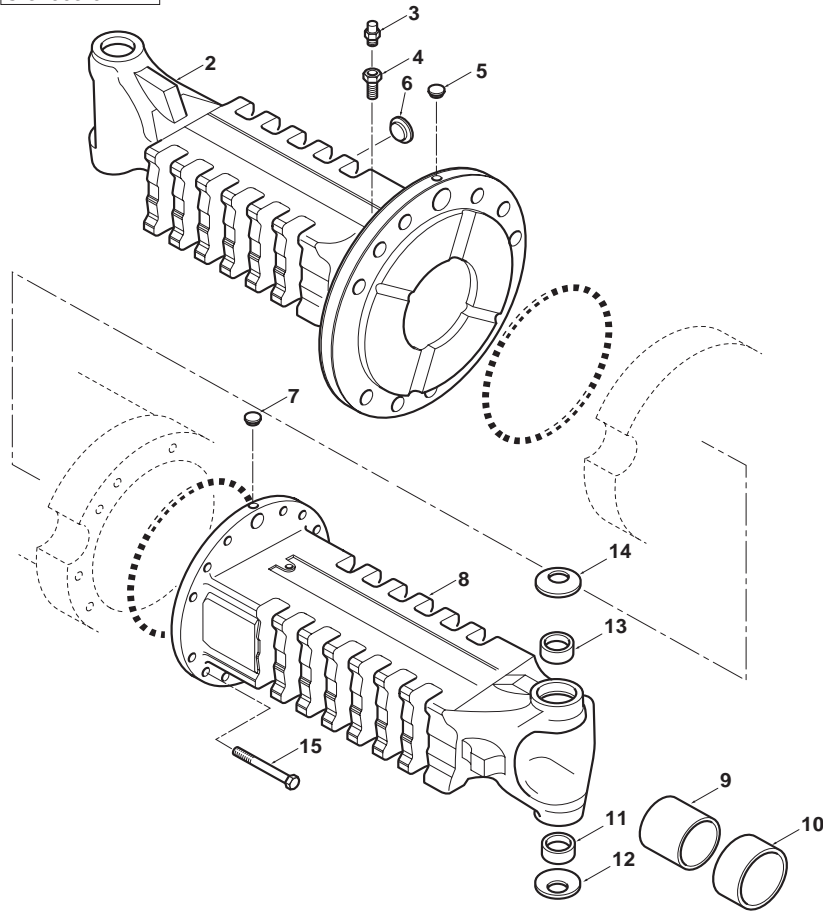

1	6109185M91		Continued Ref: 148405	1	Axle Assy, Rear	Mont. d'essieu, arrière	Puente trasero, Conj.
2	6193671M1	1	▶	1	Housing, Axle	Carter de pont	Cárter de puente
3	6193669M1	1	M10	1	Breather	Reniflard	Ventilador del cárter
4	6193338M1	1	Breather	1	Pipe	Tuyau	Tubo
5	3523998M1	1	M10 x 1	1	Plug	Bouchon	Tapón
6	3523632M1	1	M30 x 2	2	Plug	Bouchon	Tapón
7	3523998M1	1	M10 x 1	1	Plug	Bouchon	Tapón
8	6194288M1	1	◀	1	Housing, Axle	Carter de pont	Cárter de puente
9	6190247M1	1		2	Bushing	Bague	Anillo
10	6193672M1	1		2	Seal, Ring	Joint, anneau	Junta de anillo
11	3523581M1	1		2	Bushing	Bague	Anillo
12	3523579M1	1		2	Washer	Rondelle	Arandela
13	6194263M1	1		2	Bush	Bague	Casquillo
14	3523578M1	1		2	Washer	Rondelle	Arandela
15	6193673M1	1	M14 x 140	22	Bolt	Boulon	Perno



970 980
TX970B

921 922 923 931 932

37003C02.1

6199042M3

1

Jan-06

Rear Axle
Essieu Arrière
Eje trasero

Steering Pivot
Pivot de Direction
Pivote de dirección

4 Wheel Steer
4 Roues Directrices
Dirección en las 4 ruedas

C-37003-04.1-A

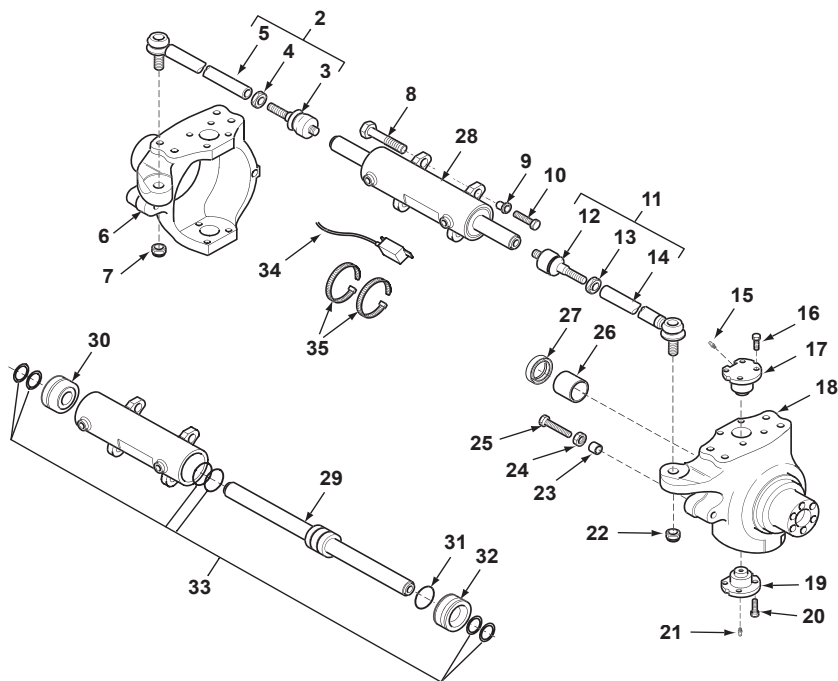

1	6109185M91		Continued Ref: 148405	1	Axle Assy, Rear	Mont. d'essieu, arrière	Puente trasero, Conj.
2	6194264M91	1		1	Arm Assy	Ensemble de bras	Brazo, Conj.
3	6194265M91	2		1	Ball Joint Assy	Ensemble de rotule	Rotula, Conj.
4	6193677M1	2	M24	1	Nut	Écrou	Tuerca
5	6194266M91	2		1	Tie Rod Assy	Barre direction, mont.	Barra dirección, Conj.
6	6194268M1	1	▶	1	Housing, Swivel	Carter, pivot	Cárter, junta giratoria
7	6194269M1	1	M24 x 1.5	1	Nut	Écrou	Tuerca
8	6193681M1	1	M22 x 55	2	Bolt	Boulon	Perno
9	6193682M1	1		2	Bush	Bague	Casquillo
10	3475604M1	1	M14 x 65	2	Screw	Vis	Tornillo
11	6194264M91	1		1	Arm Assy	Ensemble de bras	Brazo, Conj.
12	6194265M91	1		1	Ball Joint Assy	Ensemble de rotule	Rotula, Conj.
13	6193677M1	1	M24	1	Nut	Écrou	Tuerca
14	6194266M91	1		1	Tie Rod Assy	Barre direction, mont.	Barra dirección, Conj.
15	6190567M1	1		2	Fitting, Grease	Graisneur	Engrasador
16	3523597M1	1	M16 x 38	8	Screw	Vis	Tornillo
17	6194275M1	1		2	Pin, King	Axe de pivotement	Pasador principal
18	6194274M1	1	◀	1	Housing, Swivel	Carter, pivot	Cárter, junta giratoria
19	6193283M1	1		2	Pin, King	Axe de pivotement	Pasador principal
20	3523597M1	1	M16 x 38	8	Screw	Vis	Tornillo
21	6190567M1	1		2	Fitting, Grease	Graisneur	Engrasador
22	6194269M1	1	M24 x 1.5	1	Nut	Écrou	Tuerca
23	6194291M1	1		4	Bush	Bague	Casquillo
24	6194272M1	1	M16	4	Nut	Écrou	Tuerca
25	6194020M1	1	M16 x 100	4	Bolt	Boulon	Perno
26	6190264M1	1		2	Bushing	Bague	Anillo
27	6193448M1	1		2	Seal	Joint	Junta
28	6194290M91	1	● 17002C02.1	29	Cylinder, Steering	Vérin de direction	Gato de dirección
29	6193683M91	28		1	Rod Assy	Ensemble tringlerie	Tirantes, Conj.
30	6193684M1	28		1	Head, Cylinder	Culasse	Culata
31	6194277M1	28		1	Ring, Special	Jonc	Junquillo
32	6193684M1	28		1	Head, Cylinder	Culasse	Culata
33	6193685M91	28		1	Kit, Seal	Pochette de joints	Juego de juntas
34	6194276M91	1		1	Sensor	Capteur	Captador
35	6194287M1	1		2	Clamp	Collier de serrage	Argolla de cierre



970 980
TX970B

921 922 923 931 932

37003C04.1

6199042M3

1

Jan-06

Rear Axle
Essieu Arrière
Eje trasero

Wheel Hub
Moyeu de Roue
Cubo de rueda

2 Wheel Steer
2 Roues Directrices
Dirección en 2 ruedas

C-37001-04.1-A

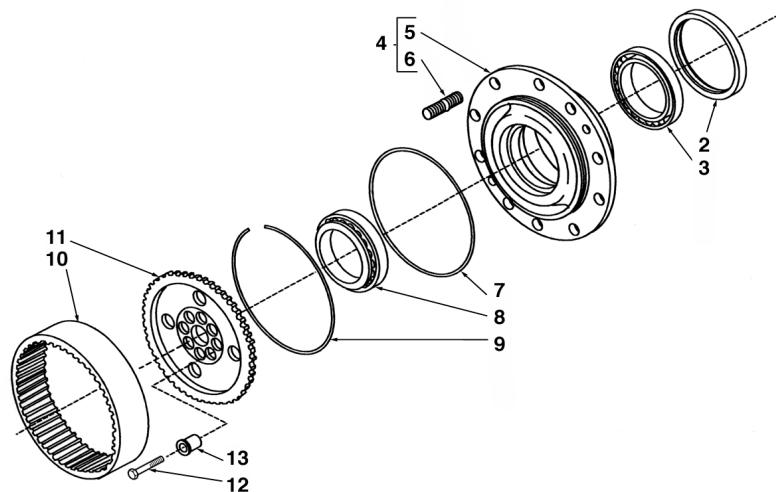

1	6109183M91			1	Axle Assy, Rear	Mont. d'essieu, arrière	Puente trasero, Conj.
2	6193408M1	1		2	Seal, Ring	Joint, anneau	Junta de anillo
3	3475599M1	1		2	Bearing, Ball	Roulement à billes	Cojinete de bolas
4	6193407M91	1		1	Hub	Moyeu	Cubo
5		4	➡ Ref. 4	1	Hub	Moyeu	Cubo
6	6190302M1	4		10	Stud	Goujon	Espárrago
7	6193409M1	1		2	O-Ring	Joint torique	Junta de tipo O
8	3475599M1	1		2	Bearing, Ball	Roulement à billes	Cojinete de bolas
9	6190290M1	1		2	Ring, Retaining	Anneau de retenue	Anillo de retención
10	6193410M1	1		2	Gear	Pignon	Piñón
11	6193411M1	1		2	Carrier	Support	Portador
12	3475604M1	1	M14 x 65	16	Screw	Vis	Tornillo
13	3523272M1	1	dia 20	16	Bushing	Bague	Anillo



820 860 880
TX760B TX860B
TX870B

801 802 803 804 805 806 807 808 809 810 811 812 813 814 815 816 817 831 832
833 834 841 842 843 844 845

37001C04.1

6199042M3

1

Jan-06

Rear Axle
Essieu Arrière
Eje trasero

Wheel Hub
Moyeu de Roue
Cubo de rueda

2 Wheel Steer
2 Roues Directrices
Dirección en 2 ruedas

C-37002-04.1-A

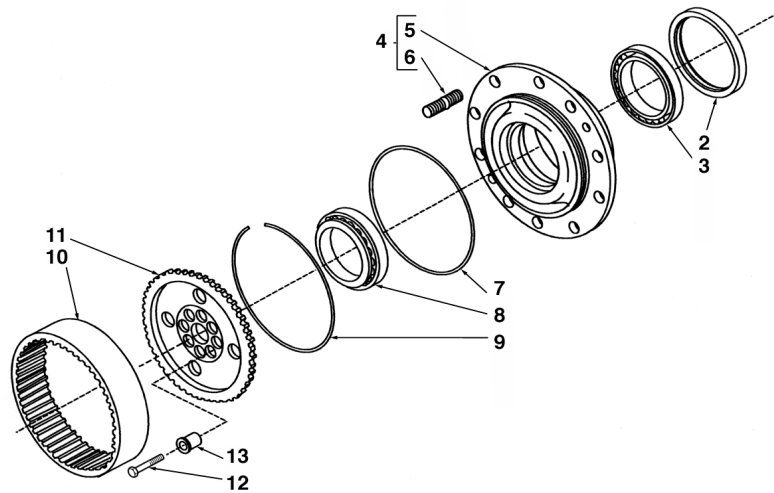

1	6109184M91			1	Axle Assy, Rear	Mont. d'essieu, arrière	Puente trasero, Conj.
2	6193408M1	1		2	Seal, Ring	Joint, anneau	Junta de anillo
3	3475599M1	1		2	Bearing, Ball	Roulement à billes	Cojinete de bolas
4	6193407M91	1		1	Hub	Moyeu	Cubo
5		4	➡ Ref. 4	1	Hub	Moyeu	Cubo
6	6190302M1	4		10	Stud	Goujon	Espárrago
7	6193409M1	1		2	O-Ring	Joint torique	Junta de tipo O
8	3475599M1	1		2	Bearing, Ball	Roulement à billes	Cojinete de bolas
9	6190290M1	1		2	Ring, Retaining	Anneau de retenue	Anillo de retención
10	6193410M1	1		2	Gear	Pignon	Piñón
11	6193411M1	1		2	Carrier	Support	Portador
12	3475604M1	1	M14 x 65	16	Screw	Vis	Tornillo
13	3523272M1	1	dia 20	16	Bushing	Bague	Anillo



860 880
TX860B TX870B

821 822 823 824 825 851 852 853 854 855

37002C04.1

6199042M3

1

Jan-06

Rear Axle
Essieu Arrière
Eje trasero

Wheel Hub
Moyeu de Roue
Cubo de rueda

4 Wheel Steer
4 Roues Directrices
Dirección en las 4 ruedas

C-37003-05.1-A

1	6109185M91		Continued Ref: 148405	1	Axle Assy, Rear	Mont. d'essieu, arrière	Puente trasero, Conj.
2	6193704M1	1		2	Seal, Ring	Joint, anneau	Junta de anillo
3	3475599M1	1		2	Bearing, Ball	Roulement à billes	Cojinete de bolas
4	6194284M91	1		1	Wheel Hub, Assy	Moyeu roue, montage	Cubo de rueda, Conj.
5		4	➡ Ref. 4	1	Hub	Moyeu	Cubo
6	6190302M1	4		10	Stud	Goujon	Espárrago
7	6193409M1	1		2	O-Ring	Joint torique	Junta de tipo O
8	3475599M1	1		2	Bearing, Ball	Roulement à billes	Cojinete de bolas
9	6190290M1	1		2	Ring, Retaining	Anneau de retenue	Anillo de retención
10	6193410M1	1		2	Gear	Pignon	Piñón
11	6193411M1	1		2	Carrier	Support	Portador
12	3475604M1	1	M14 x 65	16	Screw	Vis	Tornillo
13	3523272M1	1	dia 20	16	Bushing	Bague	Anillo

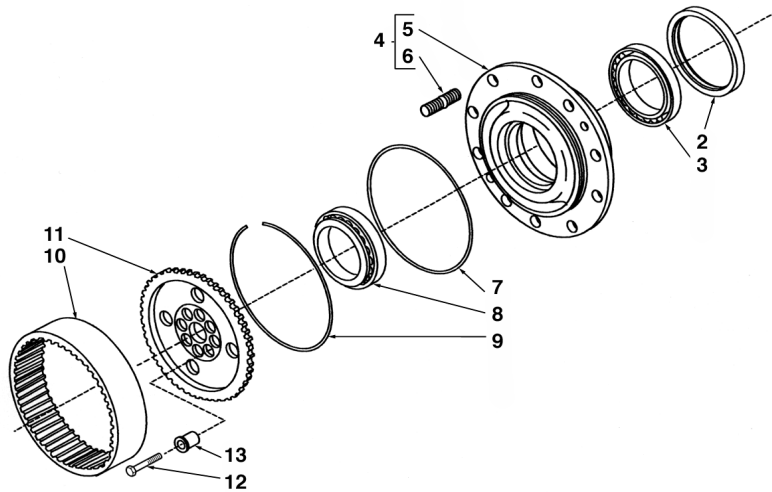

970 980
TX970B

921 922 923 931 932

37003C05.1

6199042M3

1

Jan-06

Service Brake
Frein de Service
Freno de servicio

Brake Circuit
Circuit de Freinage
Circuito de freno

C-43010-01.1-B

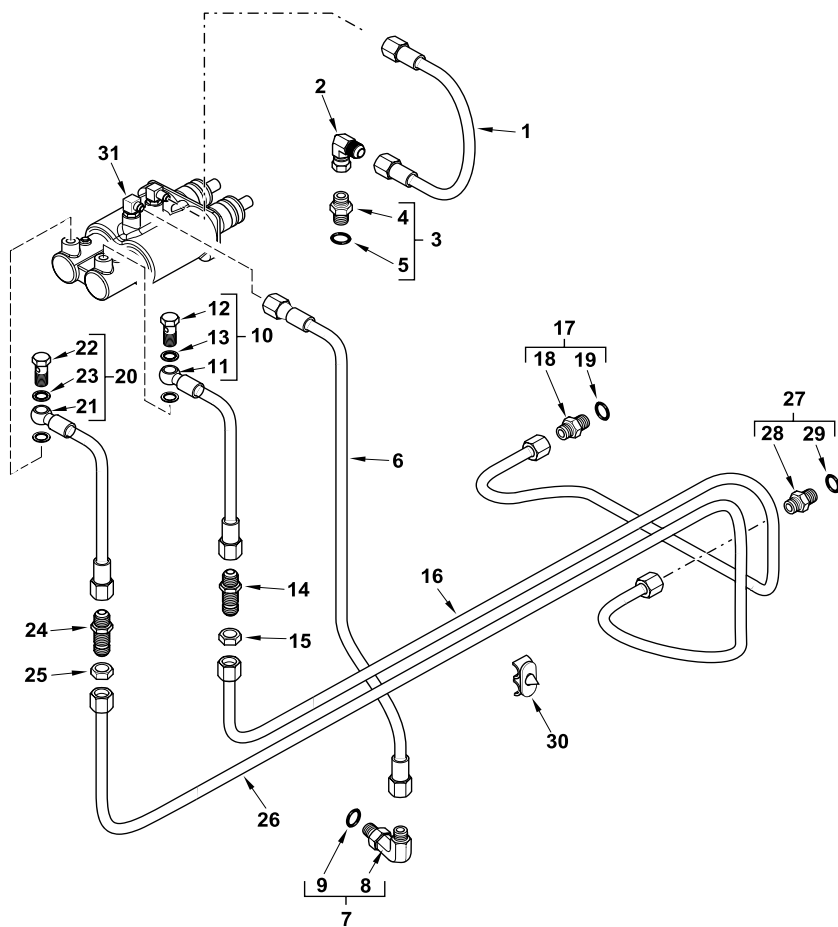

1	6110256M91			1	Hose Assy	Ensemble de flexible	Flexible, Conj.
2	368517X1			1	Elbow, 90°	Coude à 90°	Codo, 90°
3	3019375X91			1	Connector Assy	Ensemble connexion	Conexión, Conj.
4		3	▶ Ref. 3	1	Connector	Connecteur	Conector
5		3	▶ Ref. 3	1	O-Ring	Joint torique	Junta de tipo O
6	6110257M91			1	Hose Assy	Ensemble de flexible	Flexible, Conj.
7	357197X91			1	Elbow, 90°	Coude à 90°	Codo, 90°
8		7	▶ Ref. 7	1	Elbow	Coude	Codo
9	831452M1	7		1	O-Ring	Joint torique	Junta de tipo O
10	6110858M91	Brakes RH		1	Hose Assy	Ensemble de flexible	Flexible, Conj.
11		10	▶ Ref. 10	1	Hose	Flexible	Tubo flexible
12		10	▶ Ref. 10	1	Bolt	Boulon	Perno
13		10	▶ Ref. 10	2	Seal	Joint	Junta
14	356265X1			1	Connector	Connecteur	Conector
15	356613X1			1	Nut	Écrou	Tuerca
16	6109188M92		▶	1	Tube Assy	Tuyauterie	Conjunto de tubería
17	6106477M91			1	Connector Assy	Ensemble connexion	Conexión, Conj.
18		17	▶ Ref. 17	1	Connector	Connecteur	Conector
19		17	▶ Ref. 17	1	O-Ring	Joint torique	Junta de tipo O
20	6110857M91	Brakes LH		1	Hose Assy	Ensemble de flexible	Flexible, Conj.
21		20	▶ Ref. 20	1	Hose	Flexible	Tubo flexible
22		20	▶ Ref. 20	1	Bolt	Boulon	Perno
23		20	▶ Ref. 20	2	Seal	Joint	Junta
24	356265X1			1	Connector	Connecteur	Conector
25	356613X1			1	Nut	Écrou	Tuerca
26	6109186M92		◀	1	Tube Assy	Tuyauterie	Conjunto de tubería
27	6106477M91			1	Connector Assy	Ensemble connexion	Conexión, Conj.
28		27	▶ Ref. 27	1	Connector	Connecteur	Conector
29		27	▶ Ref. 27	1	O-Ring	Joint torique	Junta de tipo O
30	6106274M1			2	Clip	Clip	Clip
31			◉ 41010C03.1 3	1	Cylinder, Master	Maître-cylindre	Cilindro principal



860 880
 TX860B TX870B

821 822 823 824 825 851 852 853 854 855

Service Brake
Frein de Service
Freno de servicio

Brake Circuit
Circuit de Freinage
Circuito de freno

C-43011-01.1-B

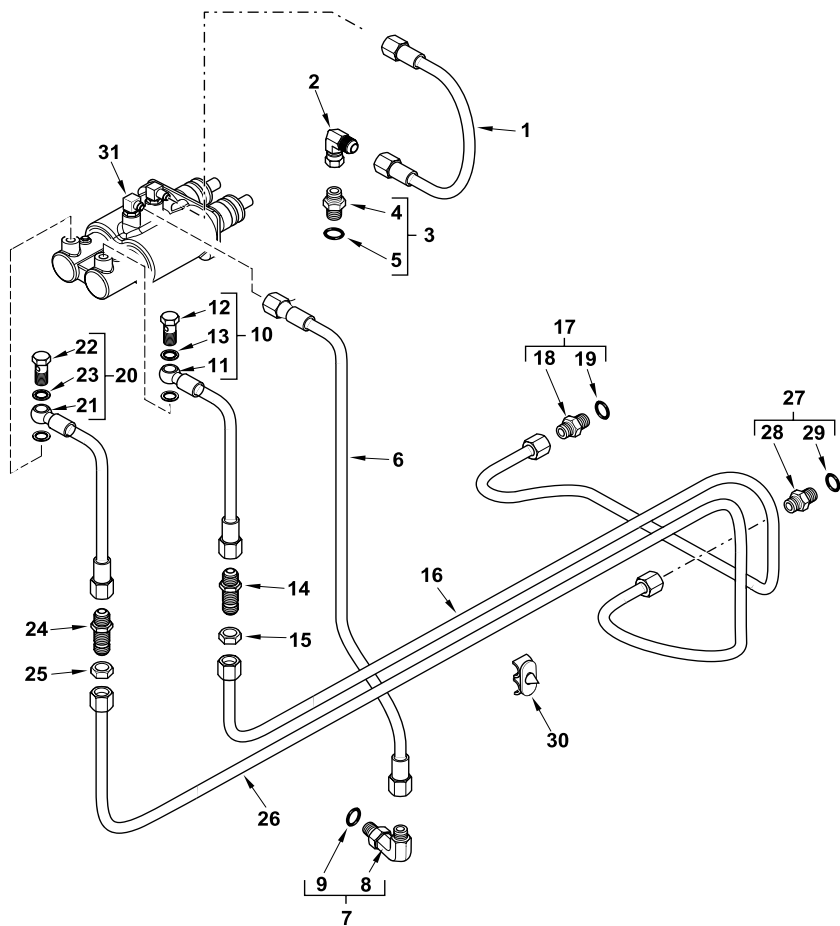

1	6110256M91			1	Hose Assy	Ensemble de flexible	Flexible, Conj.
2	368517X1			1	Elbow, 90°	Coude à 90°	Codo, 90°
3	3019375X91			1	Connector Assy	Ensemble connexion	Conexión, Conj.
4		3	▶ Ref. 3	1	Connector	Connecteur	Conector
5		3	▶ Ref. 3	1	O-Ring	Joint torique	Junta de tipo O
6	6110257M91			1	Hose Assy	Ensemble de flexible	Flexible, Conj.
7	357197X91			1	Elbow, 90°	Coude à 90°	Codo, 90°
8		7	▶ Ref. 7	1	Elbow	Coude	Codo
9	831452M1	7		1	O-Ring	Joint torique	Junta de tipo O
10	6110858M91	Brakes RH		1	Hose Assy	Ensemble de flexible	Flexible, Conj.
11		10	▶ Ref. 10	1	Hose	Flexible	Tubo flexible
12		10	▶ Ref. 10	1	Bolt	Boulon	Perno
13		10	▶ Ref. 10	2	Seal	Joint	Junta
14	356265X1			1	Connector	Connecteur	Conector
15	356613X1			1	Nut	Écrou	Tuerca
16	6109488M91		▶	1	Tube Assy	Tuyauterie	Conjunto de tubería
17	6106477M91			1	Connector Assy	Ensemble connexion	Conexión, Conj.
18		17	▶ Ref. 17	1	Connector	Connecteur	Conector
19		17	▶ Ref. 17	1	O-Ring	Joint torique	Junta de tipo O
20	6110857M91	Brakes LH		1	Hose Assy	Ensemble de flexible	Flexible, Conj.
21		20	▶ Ref. 20	1	Hose	Flexible	Tubo flexible
22		20	▶ Ref. 20	1	Bolt	Boulon	Perno
23		20	▶ Ref. 20	2	Seal	Joint	Junta
24	356265X1			1	Connector	Connecteur	Conector
25	356613X1			1	Nut	Écrou	Tuerca
26	6109486M91		◀	1	Tube Assy	Tuyauterie	Conjunto de tubería
27	6106477M91			1	Connector Assy	Ensemble connexion	Conexión, Conj.
28		27	▶ Ref. 27	1	Connector	Connecteur	Conector
29		27	▶ Ref. 27	1	O-Ring	Joint torique	Junta de tipo O
30	6106274M1			2	Clip	Clip	Clip
31			◉ 41010C03.1 3	1	Cylinder, Master	Maître-cylindre	Cilindro principal



970 980
 TX970B

921 922 923 931 932

43011C01.1

6199042M3

1

Jan-06

**Service Brake
Frein de Service
Freno de servicio**

**Brake Circuit
Circuit de Freinage
Circuito de freno**

C-43012-01.1-B

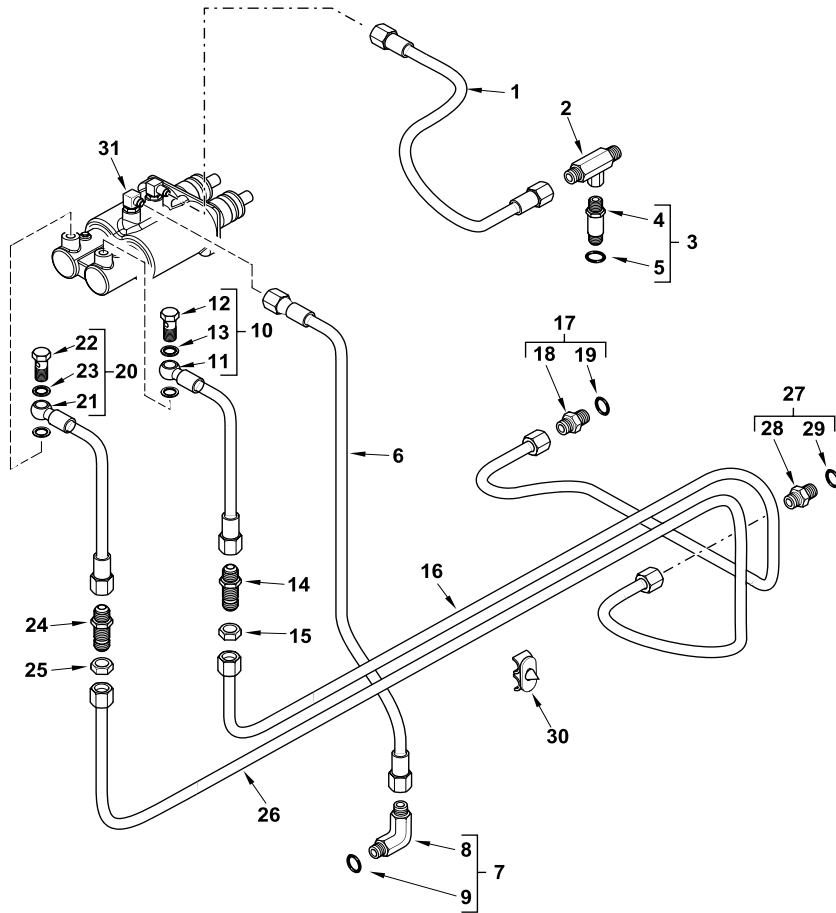

1	6110258M91		1	Hose Assy	Ensemble de flexible	Flexible, Conj.
2	364457X1	9/16"	1	Tee	Raccord en T	Te
3	371158X91		1	Connector Assy	Ensemble connexion	Conexión, Conj.
4		3 Ref. 3	1	Connector	Connecteur	Conector
5		3 Ref. 3	1	O-Ring	Joint torique	Junta de tipo O
6	6110259M91		1	Hose Assy	Ensemble de flexible	Flexible, Conj.
7	357197X91		1	Elbow, 90°	Coude à 90°	Codo, 90°
8		7 Ref. 7	1	Elbow	Coude	Codo
9	831452M1	7	1	O-Ring	Joint torique	Junta de tipo O
10	6110858M91	Brakes RH	1	Hose Assy	Ensemble de flexible	Flexible, Conj.
11		10 Ref. 10	1	Hose	Flexible	Tubo flexible
12		10 Ref. 10	1	Bolt	Boulon	Perno
13		10 Ref. 10	2	Seal	Joint	Junta
14	356265X1		1	Connector	Connecteur	Conector
15	356613X1		1	Nut	Écrou	Tuerca
16	6109188M92		1	Tube Assy	Tuyauterie	Conjunto de tubería
17	6106477M91		1	Connector Assy	Ensemble connexion	Conexión, Conj.
18		17 Ref. 17	1	Connector	Connecteur	Conector
19		17 Ref. 17	1	O-Ring	Joint torique	Junta de tipo O
20	6110857M91	Brakes LH	1	Hose Assy	Ensemble de flexible	Flexible, Conj.
21		20 Ref. 20	1	Hose	Flexible	Tubo flexible
22		20 Ref. 20	1	Bolt	Boulon	Perno
23		20 Ref. 20	2	Seal	Joint	Junta
24	356265X1		1	Connector	Connecteur	Conector
25	356613X1		1	Nut	Écrou	Tuerca
26	6109186M92		1	Tube Assy	Tuyauterie	Conjunto de tubería
27	6106477M91		1	Connector Assy	Ensemble connexion	Conexión, Conj.
28		27 Ref. 27	1	Connector	Connecteur	Conector
29		27 Ref. 27	1	O-Ring	Joint torique	Junta de tipo O
30	6106274M1		2	Clip	Clip	Clip
31		41010C03.1 3	1	Cylinder, Master	Maître-cylindre	Cilindro principal



820 860 880
TX760B TX860B
TX870B

801 802 803 804 805 806 807 808 809 810 811 812 813 814 815 816 817 831 832
833 834 841 842 843 844 845

43012C01.1

6199042M3

1

Jan-06

Service Brake
Frein de Service
Freno de servicio

Brake Circuit
Circuit de Freinage
Circuito de freno

C-43014-01.1-A

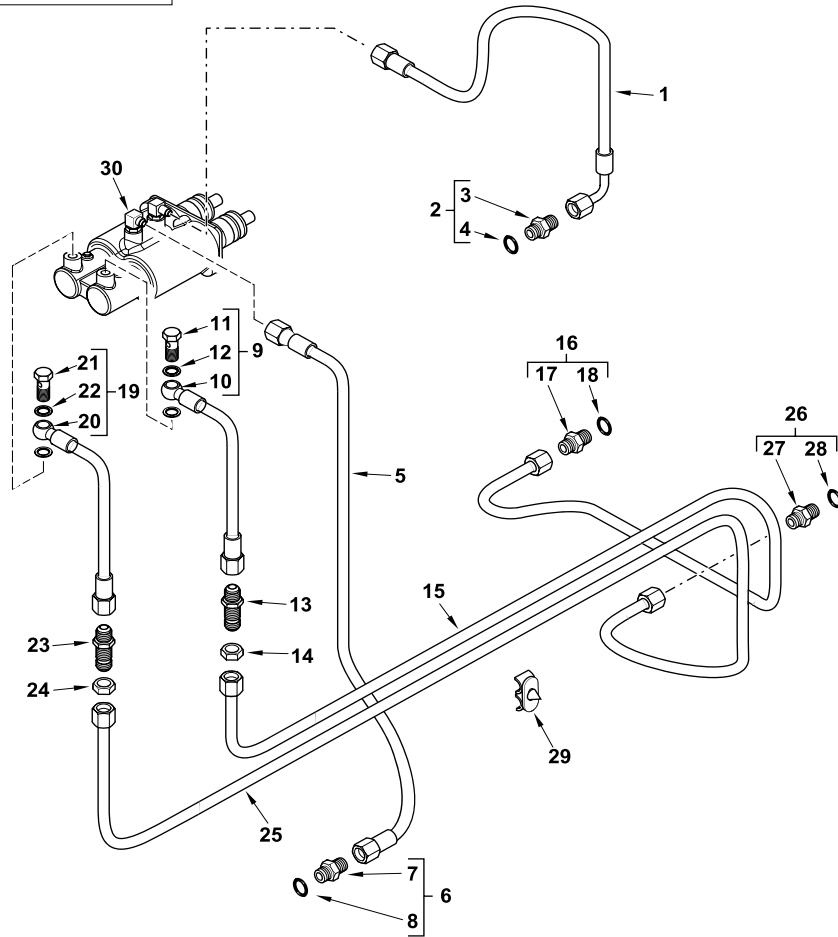

1	6110598M91		1	Hose Assy	Ensemble de flexible	Flexible, Conj.
2	835091M91	9/16	1	Union	Union	Unión
3		2  Ref. 2	1	Union	Union	Unión
4	831452M1	2	1	O-Ring	Joint torique	Junta de tipo O
5	6110599M91	Return	1	Hose Assy	Ensemble de flexible	Flexible, Conj.
6	835091M91	9/16	1	Union	Union	Unión
7		6  Ref. 6	1	Union	Union	Unión
8	831452M1	6	1	O-Ring	Joint torique	Junta de tipo O
9	6110858M91	Brakes RH	1	Hose Assy	Ensemble de flexible	Flexible, Conj.
10		9  Ref. 9	1	Hose	Flexible	Tubo flexible
11		9  Ref. 9	1	Bolt	Boulon	Perno
12		9  Ref. 9	2	Washer	Rondelle	Arandela
13	356265X1		1	Connector	Connecteur	Conector
14	356613X1		1	Nut	Écrou	Tuerca
15	6109188M92		1	Tube Assy	Tuyauterie	Conjunto de tubería
16	6106477M91		1	Connector Assy	Ensemble connexion	Conexión, Conj.
17		16  Ref. 16	1	Connector	Connecteur	Conector
18	831495M1	16	1	O-Ring	Joint torique	Junta de tipo O
19	6110857M91	Brakes LH	1	Hose Assy	Ensemble de flexible	Flexible, Conj.
20		19  Ref. 19	1	Hose	Flexible	Tubo flexible
21		19  Ref. 19	1	Bolt	Boulon	Perno
22		19  Ref. 19	2	Washer	Rondelle	Arandela
23	356265X1		1	Connector	Connecteur	Conector
24	356613X1		1	Nut	Écrou	Tuerca
25	6109186M92		1	Tube Assy	Tuyauterie	Conjunto de tubería
26	6106477M91		1	Connector Assy	Ensemble connexion	Conexión, Conj.
27		26  Ref. 26	1	Connector	Connecteur	Conector
28	831495M1	26	1	O-Ring	Joint torique	Junta de tipo O
29	6106274M1		2	Clip	Clip	Clip
30		 41010C03.1 3	1	Cylinder, Master	Maître-cylindre	Cilindro principal



820 860 880
 TX760B TX860B
 TX870B

803 804 807 808 813 814 815 816 817 841 842 843 844 845

43014C01.1

6199042M3

1

Jan-06

Torque Converter
 Convertisseur
 Convertidor de par

Powershift
 Powershift
 Powershift

C-27002-01.1-A

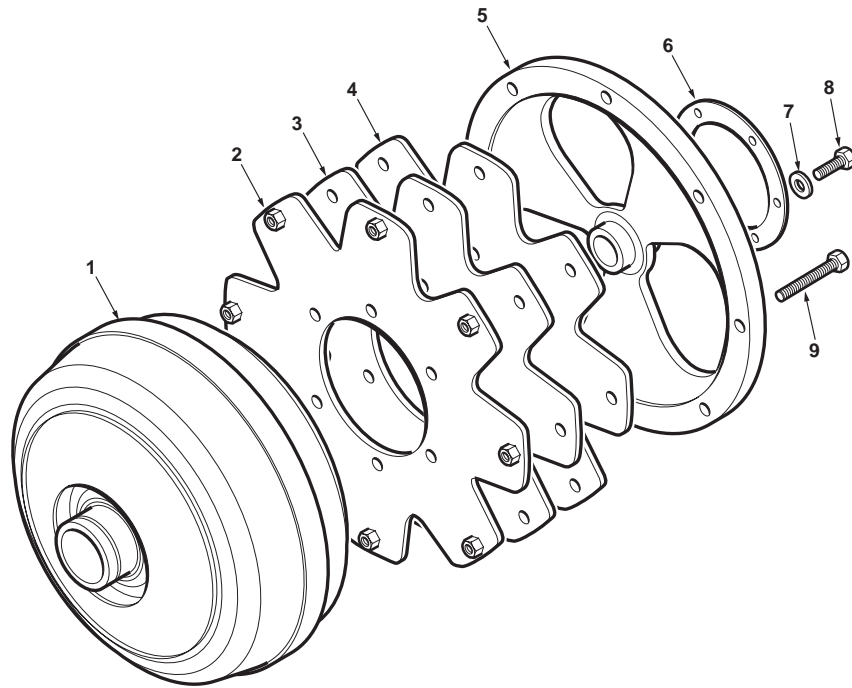

1	6109200M91			1	Torque Converter	Convertisseur couple	Convertidor de par
2	6109130M91			1	Plate Assy	Ensemble de plaque	Placa, Conj.
3	6109128M1			1	Plate, Drive	Disque d'entraînement	Disco accionamiento
4	6109128M1			1	Plate, Drive	Disque d'entraînement	Disco accionamiento
5	6109201M1			1	Adaptor	Adaptateur	Adaptador
6	6106263M1			1	Plate, Ring	Plaque en anneau	Placa de anillo
7	385361X1	M8		6	Washer	Rondelle	Arandela
8	339124X1	M8 x 16		6	Screw	Vis	Tornillo
9	6110536M1	M10 x 1.25 x 70		8	Bolt	Boulon	Perno



860 880 970 980
 TX860B TX870B
 TX970B

821 822 823 824 825 851 852 853 854 855 921 922 923 931 932

27002C01.1

6199042M3

1

Jan-06

**Torque Converter
 Convertisseur
 Convertidor de par**

C-27010-01.1-A

1	6109142M91		1	Torque Converter	Convertisseur couple	Convertidor de par
2	6109205M1		1	Adaptor	Adaptateur	Adaptador
3	6109196M1		1	Plate, Drive	Disque d'entraînement	Disco accionamiento
4	6109195M1		1	Plate, Ring	Plaque en anneau	Placa de anillo
5	390734X1	M10	6	Washer	Rondelle	Arandela
6	1440433X1	M10 x 16	6	Screw	Vis	Tornillo
7	3009497X1	M10 x 50	8	Bolt	Boulon	Perno

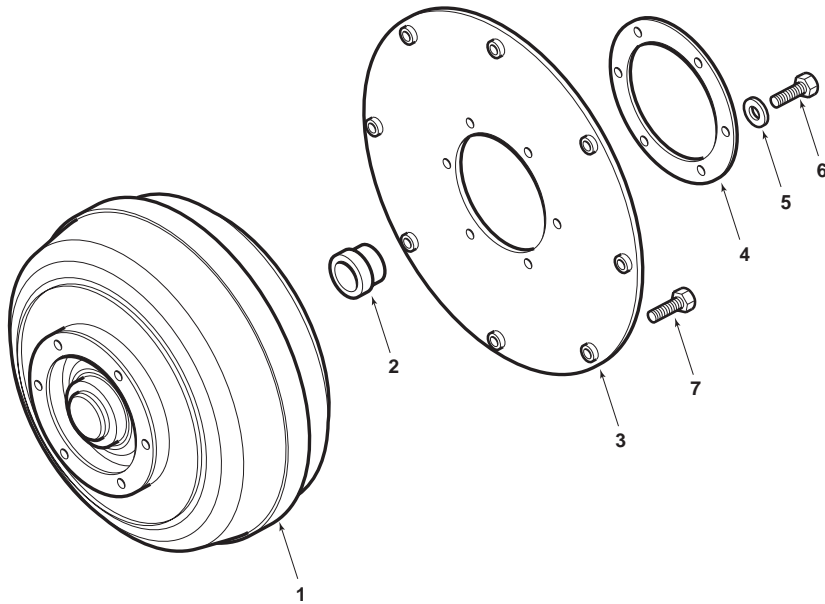

820 860 880
 TX760B TX860B
 TX870B

801 802 803 804 805 806 807 808 809 810 811 812 813 814 815 816 817 831 832
 833 834 841 842 843 844 845

27010C01.1

6199042M3

1

Jan-06

**Torque Converter
 Convertisseur
 Convertidor de par**

**Hydraulic Lines
 Circuit Hydraulique
 Circuito hidráulico**

C-39001-01.1-A

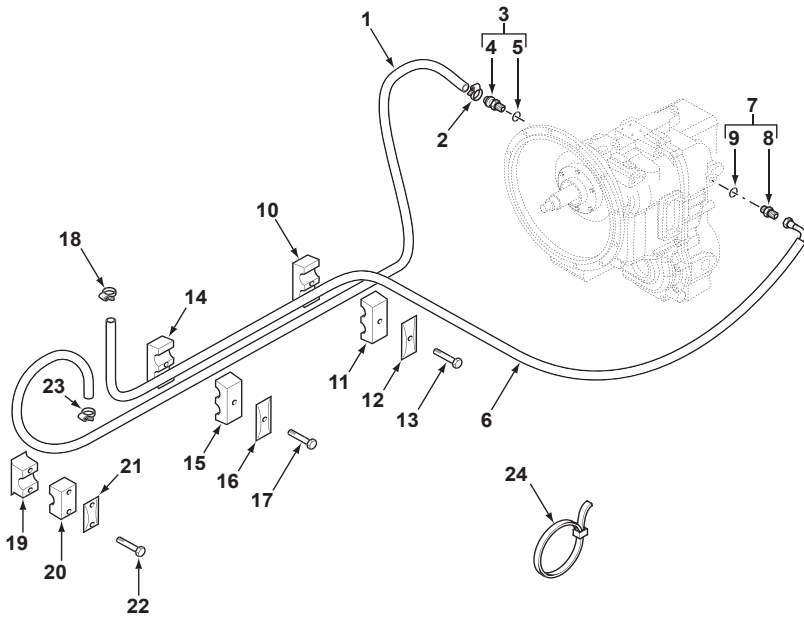

1	6110166M91			1	Hose Assy	Ensemble de flexible	Flexible, Conj.
2	3517410M1			1	Clip	Clip	Clip
3	6107562M92			1	Adaptor Assy	Ensemble d'adaptateur	Adaptador, Conj.
4		3	➡ Ref. 3	1	Adaptor	Adaptateur	Adaptador
5	835024M1	3		1	O-Ring	Joint torique	Junta de tipo O
6	6109117M91			1	Hose Assy	Ensemble de flexible	Flexible, Conj.
7	835013M91			1	Connector Assy	Ensemble connexion	Conexión, Conj.
8		7	➡ Ref. 7	1	Union	Union	Unión
9	835024M1	7		1	O-Ring	Joint torique	Junta de tipo O
10	6107502M1			1	Clamp	Collier de serrage	Argolla de cierre
11	6107502M1			1	Clamp	Collier de serrage	Argolla de cierre
12	1470376M1			1	Plate	Plaque	Placa
13	339011X1	M8 x 45		1	Bolt	Boulon	Perno
14	6107502M1			1	Clamp	Collier de serrage	Argolla de cierre
15	6107502M1			1	Clamp	Collier de serrage	Argolla de cierre
16	1470376M1			1	Plate	Plaque	Placa
17	339011X1	M8 x 45		1	Bolt	Boulon	Perno
18	3517410M1			1	Clip	Clip	Clip
19	3520340M3			1	Clamp	Collier de serrage	Argolla de cierre
20	1462584M1			1	Clamp	Collier de serrage	Argolla de cierre
21	1462583M1			1	Plate	Plaque	Placa
22	391244X1	M6 x 45		2	Bolt	Boulon	Perno
23	3517410M1			1	Clip	Clip	Clip
24	1876229M1			2	Tie, Cable	Attache câble	Enlace de Cable



820 860 880
 TX760B TX860B
 TX870B

801 802 803 804 805 806 807 808 809 810 811 812 813 814 815 816 817 831 832
 833 834 841 842 843 844 845

**Torque Converter
 Convertisseur
 Convertidor de par**

**Hydraulic Lines
 Circuit Hydraulique
 Circuito hidráulico**

**Powershift
 Powershift
 Powershift**

C-39002-01.1-A

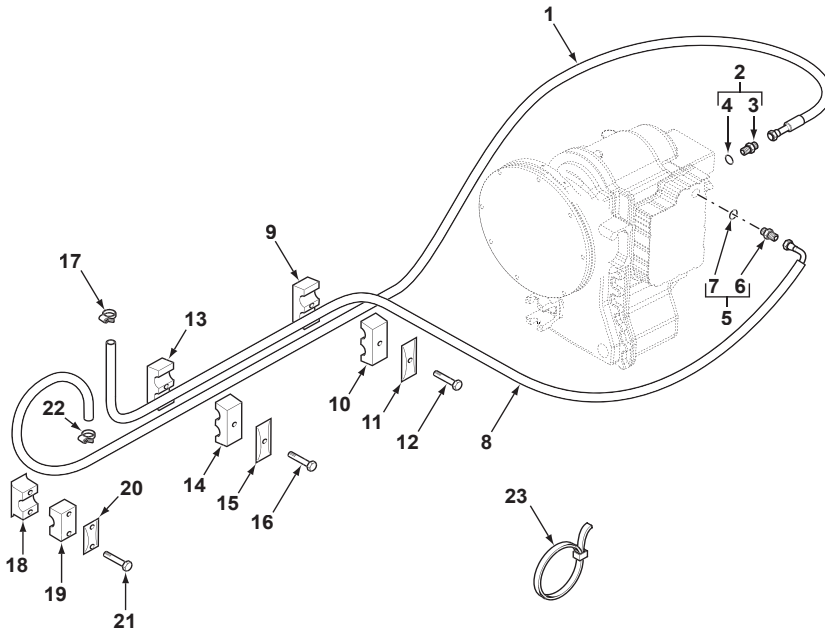

1	6109474M91		1	Hose Assy	Ensemble de flexible	Flexible, Conj.
2	365715X91	1,1/16" - 7/8" UNF	1	Connector Assy	Ensemble connexion	Conexión, Conj.
3		2  Ref. 2	1	Union	Union	Unión
4	835025M1	2	1	O-Ring	Joint torique	Junta de tipo O
5	365715X91	1,1/16" - 7/8" UNF	1	Connector Assy	Ensemble connexion	Conexión, Conj.
6		5  Ref. 5	1	Union	Union	Unión
7	835025M1	5	1	O-Ring	Joint torique	Junta de tipo O
8	6109475M91		1	Hose Assy	Ensemble de flexible	Flexible, Conj.
9	6107502M1		1	Clamp	Collier de serrage	Argolla de cierre
10	6107502M1		1	Clamp	Collier de serrage	Argolla de cierre
11	1470376M1		1	Plate	Plaque	Placa
12	339011X1	M8 x 45	1	Bolt	Boulon	Perno
13	6107502M1		1	Clamp	Collier de serrage	Argolla de cierre
14	6107502M1		1	Clamp	Collier de serrage	Argolla de cierre
15	1470376M1		1	Plate	Plaque	Placa
16	339011X1	M8 x 45	1	Bolt	Boulon	Perno
17	3517410M1		1	Clip	Clip	Clip
18	3520340M3		1	Clamp	Collier de serrage	Argolla de cierre
19	1462584M1		1	Clamp	Collier de serrage	Argolla de cierre
20	1462583M1		1	Plate	Plaque	Placa
21	391244X1	M6 x 45	2	Bolt	Boulon	Perno
22	3517410M1		1	Clip	Clip	Clip
23	1876229M1		3	Tie, Cable	Attache câble	Enlace de Cable



860 880 970 980
 TX860B TX870B
 TX970B

821 822 823 824 825 851 852 853 854 855 921 922 923 931 932

**Torque Converter
 Convertisseur
 Convertidor de par**

**Hydraulic Lines
 Circuit Hydraulique
 Circuito hidráulico**

C-39003-01.1-A

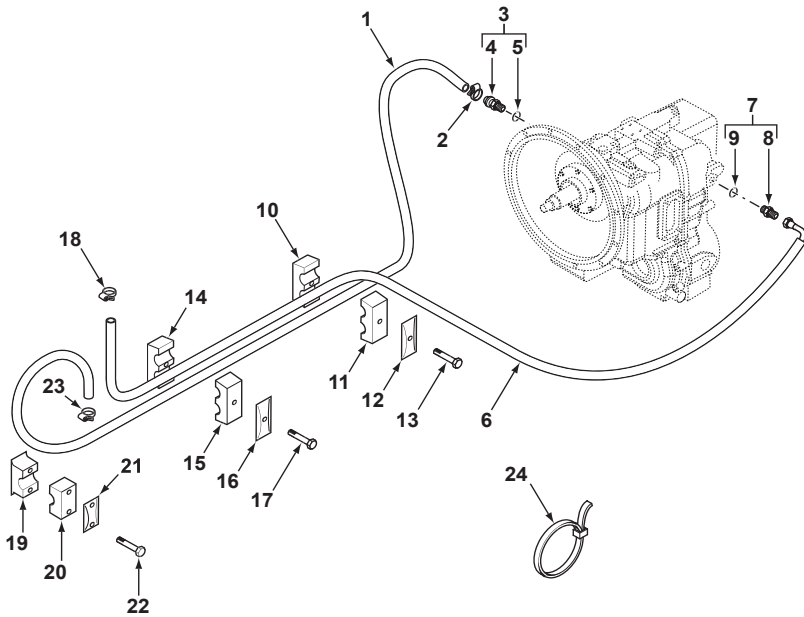

1	6110166M91			1	Hose Assy	Ensemble de flexible	Flexible, Conj.
2	3517410M1			1	Clip	Clip	Clip
3	6107562M92			1	Adaptor Assy	Ensemble d'adaptateur	Adaptador, Conj.
4		3	➡ Ref. 3	1	Adaptor	Adaptateur	Adaptador
5	835024M1	3		1	O-Ring	Joint torique	Junta de tipo O
6	6110595M91			1	Hose Assy	Ensemble de flexible	Flexible, Conj.
7	835013M91			1	Connector Assy	Ensemble connexion	Conexión, Conj.
8		7	➡ Ref. 7	1	Union	Union	Unión
9	835024M1	7		1	O-Ring	Joint torique	Junta de tipo O
10	6107502M1			1	Clamp	Collier de serrage	Argolla de cierre
11	6107502M1			1	Clamp	Collier de serrage	Argolla de cierre
12	1470376M1			1	Plate	Plaque	Placa
13	339011X1	M8 x 45		1	Bolt	Boulon	Perno
14	6107502M1			1	Clamp	Collier de serrage	Argolla de cierre
15	6107502M1			1	Clamp	Collier de serrage	Argolla de cierre
16	1470376M1			1	Plate	Plaque	Placa
17	339011X1	M8 x 45		1	Bolt	Boulon	Perno
18	3517410M1			1	Clip	Clip	Clip
19	3520340M3			1	Clamp	Collier de serrage	Argolla de cierre
20	1462584M1			1	Clamp	Collier de serrage	Argolla de cierre
21	1462583M1			1	Plate	Plaque	Placa
22	391244X1	M6 x 45		2	Bolt	Boulon	Perno
23	3517410M1			1	Clip	Clip	Clip
24	1876229M1			2	Tie, Cable	Attache câble	Enlace de Cable



820 860 880
 TX760B TX860B
 TX870B

803 804 807 808 813 814 815 816 817 841 842 843 844 845

39003C01.1

6199042M3

1

Jan-06

Transmission
Transmission
Transmisión

4 Wheel Drive Shaft
Arbre de Commande 4 Roues Motrices
Árbol de arrastre 4rm

4 Wheel Drive
4 Roues Motrices
4 ruedas motrices

C-29002-08.1-A

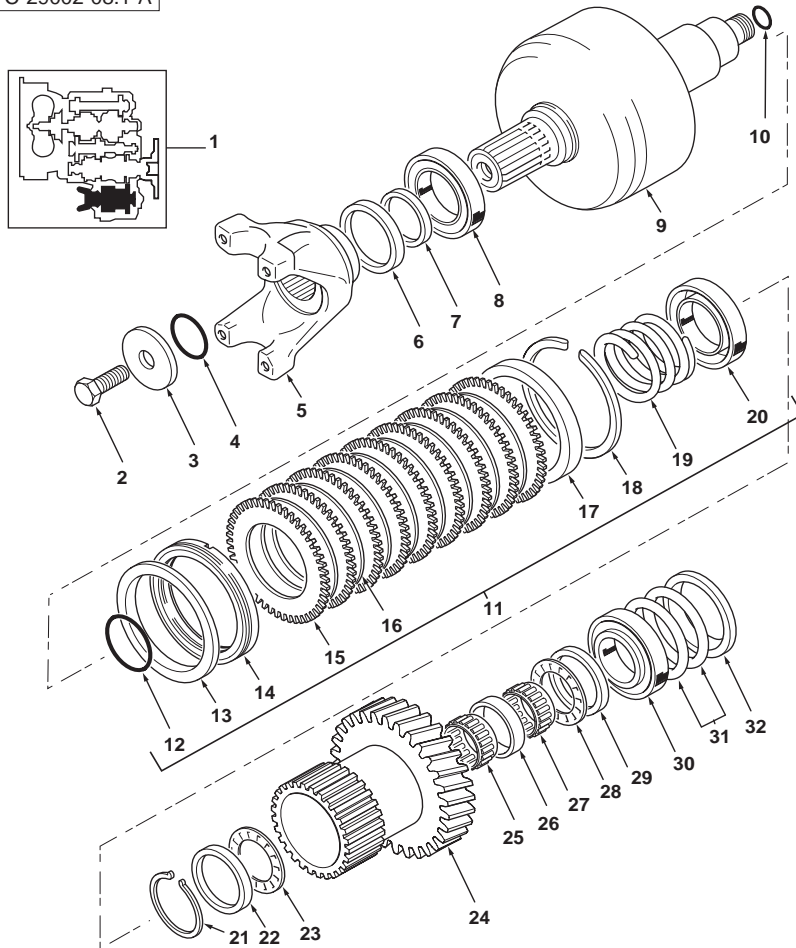

1	6108873M91		Continued 2WS	1	Gearbox	Boite de vitesses	Caja de velocidades
2	6190128M1	1		1	Screw	Vis	Tornillo
3	6190125M1	1		1	Washer	Rondelle	Arandela
4	6190129M1	1		1	O-Ring	Joint torique	Junta de tipo O
5	6190119M91	1		1	Yoke, Universal Joint	Chape de cardan	Yugo de cardán
6	6190163M1	1		1	Seal, Oil	Joint à huile	Junta de aceite
7	6190120M1	1		1	Spacer	Entretoise	Traviesa
8	6190093M91	1		1	Bearing Assy	Roulement	Rodamiento, Conj.
9	6190551M91	1		1	Shaft Assy	Ensemble de l'arbre	Árbol, Conj.
10	6190069M1	1		1	O-Ring	Joint torique	Junta de tipo O
11	6190558M91	1		1	Kit, Service	Kit d'entretien	Juego de servicio
12	6190032M1	11		1	Ring, Sealing	Bague d'étanchéité	Anillo, Estanqueidad
13	6190037M1	11		1	Seal	Joint	Junta
14	6190038M1	11		1	Piston	Piston	Pistón
15	6190042M1	11		8	Plate, Intermediate	Plaque intermédiaire	Placa intermediaria
16	6190039M1	11		8	Disc, Friction	Disque de friction	Disco de fricción
17	6190556M1	11		1	Ring	Anneau	Aro
18	6190557M1	11		1	Ring, Snap	Anneau d'arrêt	Anillo de resorte
19	6190036M1	11		1	Spring	Ressort	Muelle
20	6190118M1	11		1	Retainer	Dispositif de retenue	Fijación
21	6190168M1	1		1	Circlip	Segment d'arrêt	Circlip
22	6190177M1	1		1	Washer, Thrust	Rondelle de butée	Arandela de tope
23	6190178M1	1		1	Bearing, Thrust	Roulement butée	Cojinete axial
24	6190049M91	1	 36	1	Gear Assy	Ensemble d'engrenage	Engranaje, Conj.
25	6190180M1	1		1	Bearing, Needle	Aiguilles de roulement	Cojinete, Agujas
26	6190179M1	1		1	Spacer	Entretoise	Traviesa
27	6190180M1	1		1	Bearing, Needle	Aiguilles de roulement	Cojinete, Agujas
28	6190178M1	1		1	Bearing, Thrust	Roulement butée	Cojinete axial
29	6190052M1	1		1	Washer, Thrust	Rondelle de butée	Arandela de tope
30	6190093M91	1		1	Bearing Assy	Roulement	Rodamiento, Conj.
31	6190072M1	1	0.002"	X	Shim	Cale	Calce
31	6190073M1	1	0.003"	X	Shim	Cale	Calce
31	6190074M1	1	0.007"	X	Shim	Cale	Calce
31	6190075M1	1	0.024"	X	Shim	Cale	Calce
32	6190071M1	1		1	Spacer	Entretoise	Traviesa



820 860 880
TX760B TX860B
TX870B

803 804 807 808 813 814 815 816 817 831 832 833 834 841 842 843 844 845

29002C08.1

6199042M3

1

Jan-06

Transmission
Transmission
Transmisión

4 Wheel Drive Shaft
Arbre de Commande 4 Roues Motrices
Árbol de arrastre 4rm

4 Wheel Drive
4 Roues Motrices
4 ruedas motrices

Carraro
Carraro
Carraro

C-29005-10.1-A

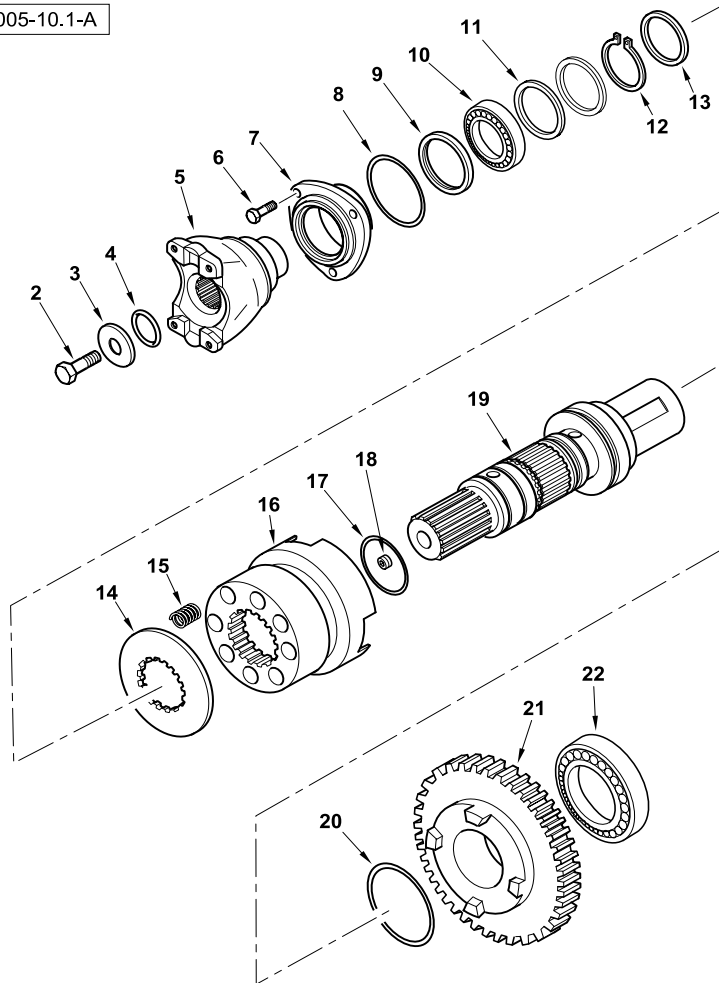

1	6110549M91		Continued	1	Gearbox	Boite de vitesses	Caja de velocidades
2	6194403M1	1	M12 x 25	1	Bolt	Boulon	Perno
3	6194414M1	1	44 x 12,5 x 5	1	Washer	Rondelle	Arandela
4	6193384M1	1		1	O-Ring	Joint torique	Junta de tipo O
5	6194417M1	1		1	Flange	Flasque	Brida de unión
6	6194416M1	1	M8 x 22	3	Bolt	Boulon	Perno
7	6194415M1	1		1	Cover	Cache	Tapa
8	6194419M1	1		1	O-Ring	Joint torique	Junta de tipo O
9	6194418M1	1	50 x 65 x 8	1	Ring, Sealing	Bague d'étanchéité	Anillo, Estanqueidad
10	6194369M1	1		1	Bearing	Coussinet	Cojinete
11	6194343M1	1	45 mm	2	Ring, Sealing	Bague d'étanchéité	Anillo, Estanqueidad
12	6193699M1	1		1	Ring, Snap	Anneau d'arrêt	Anillo de resorte
13	6194420M1	1		1	Washer	Rondelle	Arandela
14	6194428M1	1		1	Spacer	Entretoise	Traviesa
15	6194427M1	1		8	Spring	Ressort	Muelle
16	6194426M1	1		1	Sleeve	Chemise	Camisa
17	6194425M1	1		2	O-Ring	Joint torique	Junta de tipo O
18	3523998M1	1	M10 x 1	1	Plug	Bouchon	Tapón
19	6194424M1	1	Output	1	Shaft	Arbre	Árbol
20	6194423M1	1		1	O-Ring	Joint torique	Junta de tipo O
21	6194422M1	1		1	Gear	Pignon	Piñón
22	6194421M1	1		1	Bearing	Coussinet	Cojinete



820 860 880
TX760B TX860B
TX870B

803 804 807 808 813 814 815 816 817 841 842 843 844 845

29005C10.1

6199042M3

1

Jan-06

Transmission
Transmission
Transmisión

Charging Pump
Pompe de Remplissage
Bomba de carga

Powershift
Powershift
Powershift

C-29003-05.1-A

1	6108875M91		Continued 2WS	1	Gearbox	Boite de vitesses	Caja de velocidades
2	6194055M91	1		1	Shaft Assy	Ensemble de l'arbre	Árbol, Conj.
3	6194056M1	1		1	Ring, Piston	Segment de piston	Segmento de pistón
4	6194057M91	1		1	Bearing Assy	Roulement	Rodamiento, Conj.
5	6193539M1	1		1	Ring, Snap	Anneau d'arrêt	Anillo de resorte
6	6193490M1	1		1	Ring, Retaining	Anneau de retenue	Anillo de retención
7	6194058M1	1		1	Gasket	Joint	Empaquetadura
8	6194059M1	1		1	Plate	Plaque	Placa
9	6194060M1	1		4	Washer	Rondelle	Arandela
10	6194061M1	1		4	Spacer	Entretoise	Traviesa
11	6194062M1	1		4	Nut	Écrou	Tuerca

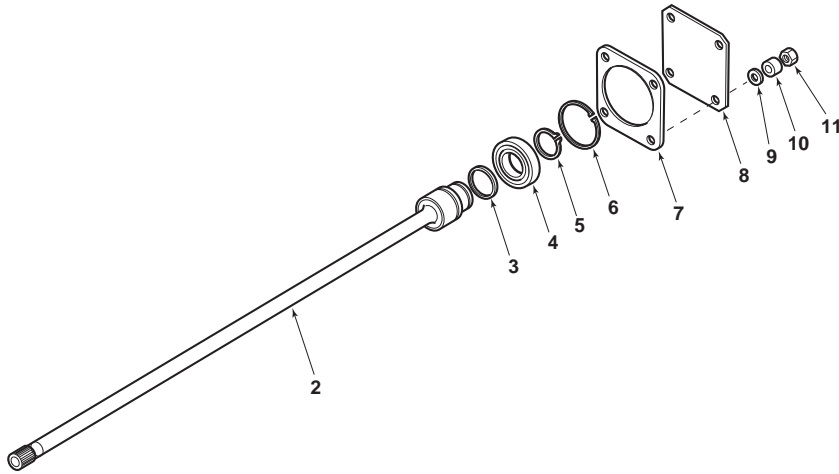

860 880
TX860B TX870B

821 822 823 824 825 851 852 853 854 855

29003C05.1

6199042M3

1

Jan-06

Transmission
Transmission
Transmisión

Charging Pump
Pompe de Remplissage
Bomba de carga

Powershift
Powershift
Powershift

C-29003-06.1-A

1	6108875M91		Continued 2WS	1	Gearbox	Boite de vitesses	Caja de velocidades
2	6193496M91	1		1	Pump Assy	Ensemble de pompe	Bomba, Conj.
3	6193497M1	1		1	O-Ring	Joint torique	Junta de tipo O
4	6193498M1	1		1	Seal, Oil	Joint à huile	Junta de aceite
5	6193499M1	1		6	Bolt	Boulon	Perno
6	6193500M1	1		6	Washer	Rondelle	Arandela

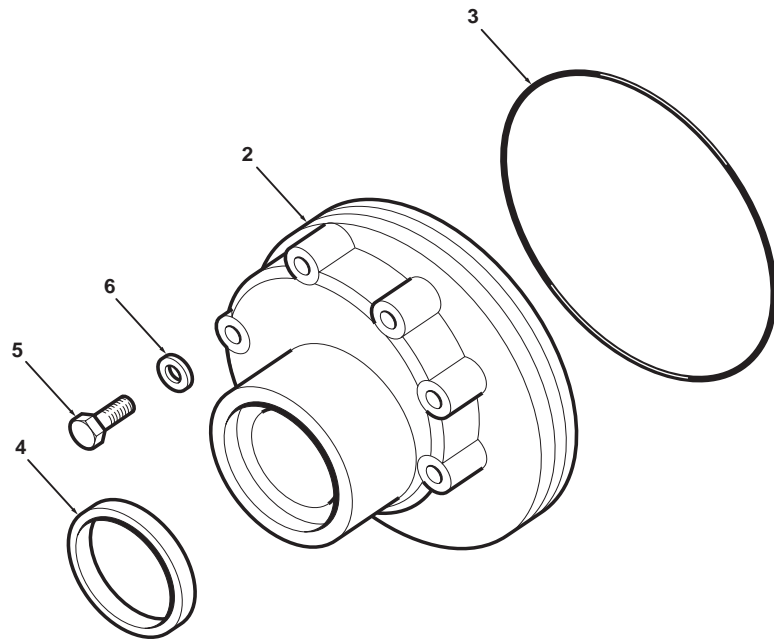

860 880
TX860B TX870B

821 822 823 824 825 851 852 853 854 855

29003C06.1

6199042M3

1

Jan-06

Transmission
Transmission
Transmisión

Charging Pump
Pompe de Remplissage
Bomba de carga

Powershift
Powershift
Powershift

C-29004-05.1-A

1	6109135M91		Continued 4WS	1	Gearbox	Boite de vitesses	Caja de velocidades
2	6194055M91	1		1	Shaft Assy	Ensemble de l'arbre	Árbol, Conj.
3	6194056M1	1		1	Ring, Piston	Segment de piston	Segmento de pistón
4	6194057M91	1		1	Bearing Assy	Roulement	Rodamiento, Conj.
5	6193539M1	1		1	Ring, Snap	Anneau d'arrêt	Anillo de resorte
6	6193490M1	1		1	Ring, Retaining	Anneau de retenue	Anillo de retención
7	6194058M1	1		1	Gasket	Joint	Empaquetadura
8	6194059M1	1		1	Plate	Plaque	Placa
9	6194060M1	1		4	Washer	Rondelle	Arandela
10	6194061M1	1		4	Spacer	Entretoise	Traviesa
11	6194062M1	1		4	Nut	Écrou	Tuerca

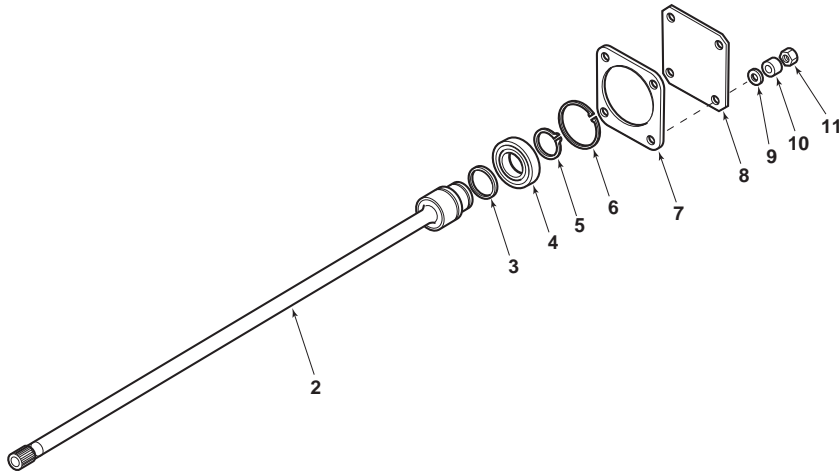

970 980
TX970B

921 922 923 931 932

29004C05.1

6199042M3

1

Jan-06

Transmission
Transmission
Transmisión

Charging Pump
Pompe de Remplissage
Bomba de carga

Powershift
Powershift
Powershift

C-29004-06.1-A

1	6109135M91		Continued 4WS	1	Gearbox	Boite de vitesses	Caja de velocidades
2	6193496M91	1		1	Pump Assy	Ensemble de pompe	Bomba, Conj.
3	6193497M1	1		1	O-Ring	Joint torique	Junta de tipo O
4	6193498M1	1		1	Seal, Oil	Joint à huile	Junta de aceite
5	6193499M1	1		6	Bolt	Boulon	Perno
6	6193500M1	1		6	Washer	Rondelle	Arandela

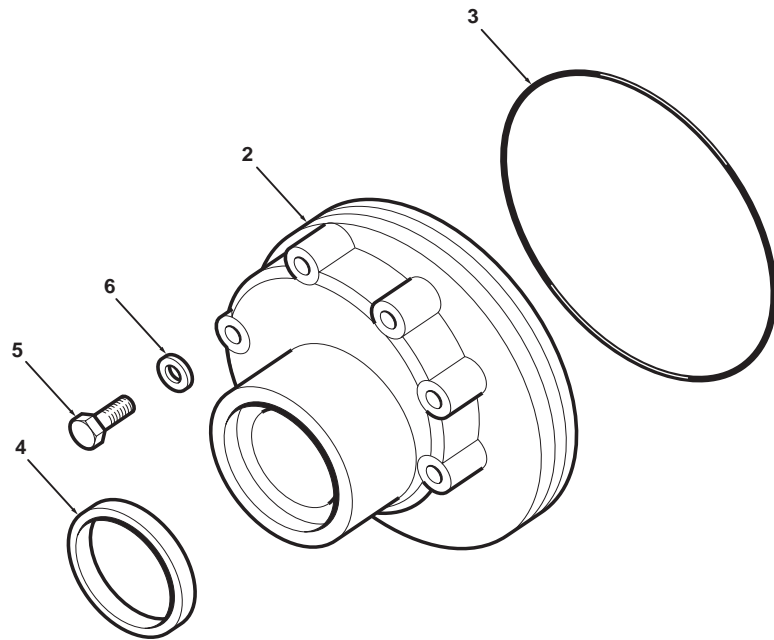

970 980
TX970B

921 922 923 931 932

29004C06.1

6199042M3

1

Jan-06

Transmission
Transmission
Transmisión

Charging Pump
Pompe de Remplissage
Bomba de carga

4 Wheel Drive
4 Roues Motrices
4 ruedas motrices

Carraro
Carraro
Carraro

C-29005-04.1-A

1	6110549M91		Continued	1	Gearbox	Boite de vitesses	Caja de velocidades
2	6194309M91	1		1	Pump Assy	Ensemble de pompe	Bomba, Conj.
3	6194310M1	1		1	O-Ring	Joint torique	Junta de tipo O
4	6194307M1	1		1	Seal, Oil	Joint à huile	Junta de aceite
5	6194308M1	1	M8 x 60	6	Screw	Vis	Tornillo

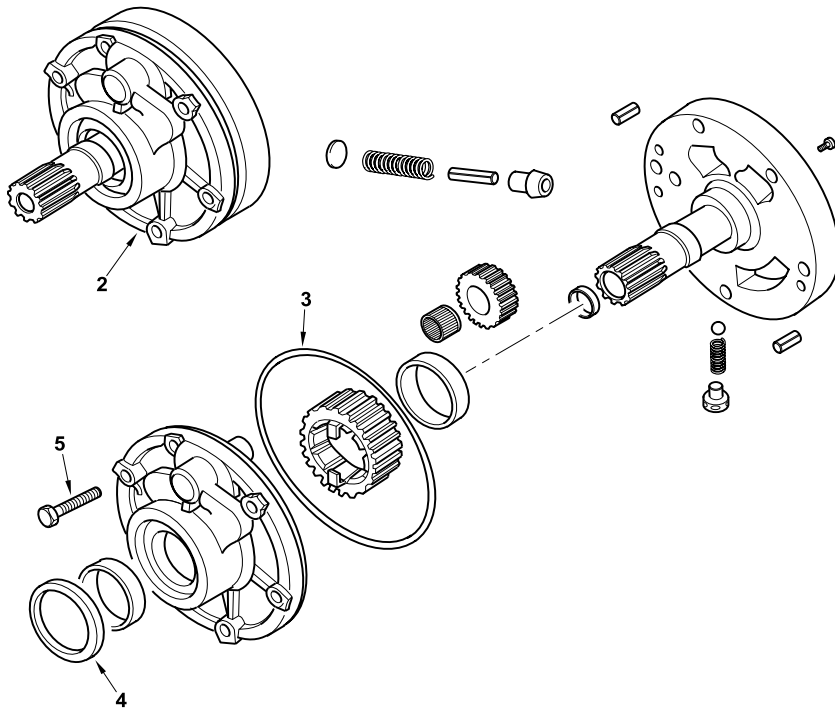

820 860 880
TX760B TX860B
TX870B

803 804 807 808 813 814 815 816 817 841 842 843 844 845

29005C04.1

6199042M3

1

Jan-06

Transmission
Transmission
Transmisión

Control Valve
Distributeur
Distribuidor de mando

Powershift
Powershift
Powershift

C-29003-13.1-A

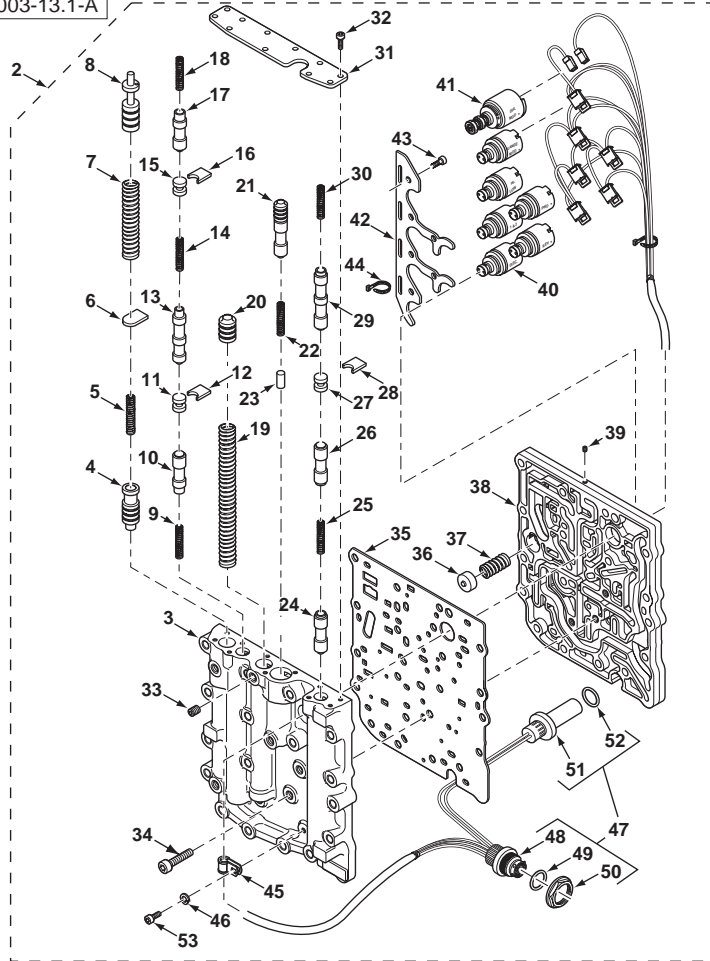

1	6108875M91		Continued 2WS	1	Gearbox	Boite de vitesses	Caja de velocidades
2	6194077M91	1	29003C12.1 2	1	Valve Assy, Control	Ensemble distribution	Distribuidor, Conj.
3		2	Ref.2	1	Body	Corps	Cuerpo
4		2	Ref.2	1	Spool	Tiroir	Cajoncillo
5		2	Ref.2	1	Spring	Ressort	Muelle
6		2	Ref.2	1	Plate	Plaque	Placa
7		2	Ref.2	1	Spring	Ressort	Muelle
8		2	Ref.2	1	Spool	Tiroir	Cajoncillo
9		2	Ref.2	1	Spring	Ressort	Muelle
10		2	Ref.2	1	Spool	Tiroir	Cajoncillo
11		2	Ref.2	1	Stop	Butée	Tope
12		2	Ref.2	1	Plate	Plaque	Placa
13		2	Ref.2	1	Spool	Tiroir	Cajoncillo
14		2	Ref.2	1	Spring	Ressort	Muelle
15		2	Ref.2	1	Stop	Butée	Tope
16		2	Ref.2	1	Plate	Plaque	Placa
17		2	Ref.2	1	Spool	Tiroir	Cajoncillo
18		2	Ref.2	1	Spring	Ressort	Muelle
19		2	Ref.2	1	Spring	Ressort	Muelle
20		2	Ref.2	1	Spool	Tiroir	Cajoncillo
21		2	Ref.2	1	Spool	Tiroir	Cajoncillo
22		2	Ref.2	1	Spring	Ressort	Muelle
23		2	Ref.2	1	Stop	Butée	Tope
24		2	Ref.2	1	Spool	Tiroir	Cajoncillo
25		2	Ref.2	1	Spring	Ressort	Muelle
26		2	Ref.2	1	Spool	Tiroir	Cajoncillo
27		2	Ref.2	1	Stop	Butée	Tope
28		2	Ref.2	1	Plate	Plaque	Placa
29		2	Ref.2	1	Spool	Tiroir	Cajoncillo
30		2	Ref.2	1	Spring	Ressort	Muelle
31		2	Ref.2	1	Cover	Cache	Tapa
32	6193569M1	2		11	Bolt	Boulon	Perno
33	6194078M1	2		3	Plug	Bouchon	Tapón
34	6193563M1	2		3	Bolt	Boulon	Perno
35		2	Ref.2	1	Plate	Plaque	Placa
36	6193564M1	2		1	Spool	Tiroir	Cajoncillo
37	6193565M1	2		1	Spring	Ressort	Muelle
38		2	Ref.2	1	Plate	Plaque	Placa
39	6193566M1	2		6	Plug	Bouchon	Tapón
40	6193567M91	2		6	Solenoid	Solénoïde	Solenoid
41	6194079M91	2		1	Valve Assy	Ensemble de soupape	Válvula, Conj.
42		2	Ref.2	1	Clamp	Collier de serrage	Argolla de cierre
43	6193569M1	2		6	Bolt	Boulon	Perno
44	6193570M1	2		6	Tie, Cable	Attache câble	Enlace de Cable



860 880
TX860B TX870B

821 822 823 824 825 851 852 853 854 855

29003C13.1

6199042M3

1

Jan-06

Transmission
Transmission
Transmisión

Control Valve
Distributeur
Distribuidor de mando

Powershift
Powershift
Powershift

C-29003-13.1-A

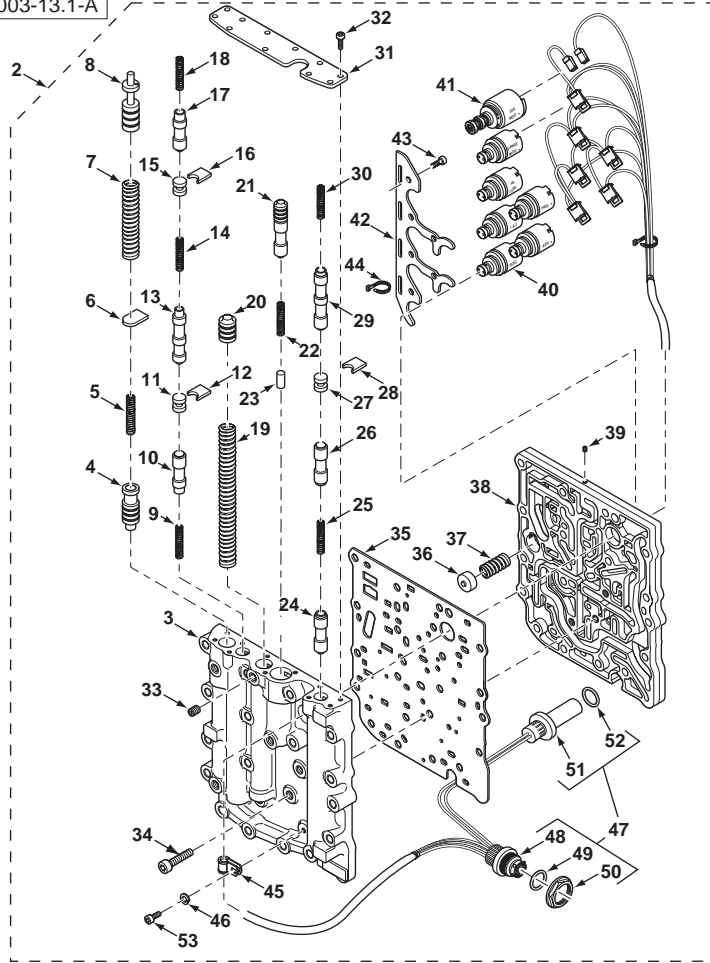

45	6193573M91	2		1	Clamp	Collier de serrage	Argolla de cierre
46	6193574M1	2		1	Washer, Lock	Rondelle de blocage	Arandela de freno
47	6194090M91	2		1	Harness Assy	Ensemble de faisceau	Haz, Conj.
48		47	➡ Ref.47	1	Harness	Faisceau	Haz
49	6193571M1	47		1	O-Ring	Joint torique	Junta de tipo O
50		47	➡ Ref.47	1	Nut	Écrou	Tuerca
51	6194080M91	47		1	Sensor	Capteur	Captador
52	6194081M1	47		1	O-Ring	Joint torique	Junta de tipo O
53	6193575M1	2		1	Bolt	Boulon	Perno



860 880
TX860B TX870B

821 822 823 824 825 851 852 853 854 855

29003C13.1

6199042M3

1

Jan-06

Transmission
Transmission
Transmisión

Control Valve
Distributeur
Distribuidor de mando

Powershift
Powershift
Powershift

C-29004-13.1-A

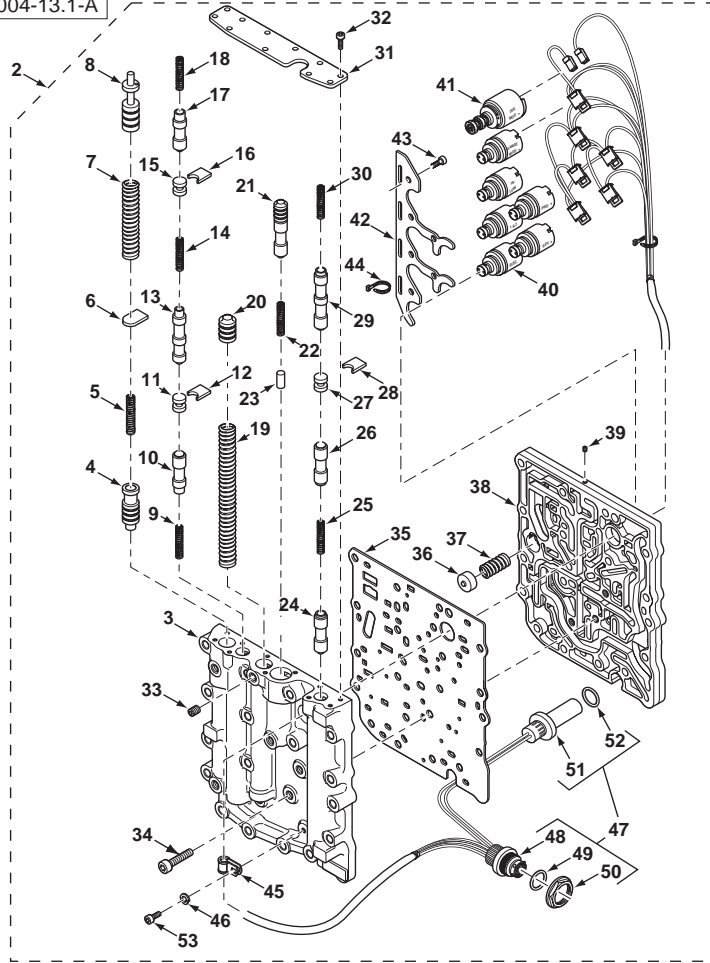

1	6109135M91		Continued 4WS	1	Gearbox	Boite de vitesses	Caja de velocidades
2	6194077M91	1	29003C12.1 2	1	Valve Assy, Control	Ensemble distribution	Distribuidor, Conj.
3		2	Ref.2	1	Body	Corps	Cuerpo
4		2	Ref.2	1	Spool	Tiroir	Cajoncillo
5		2	Ref.2	1	Spring	Ressort	Muelle
6		2	Ref.2	1	Plate	Plaque	Placa
7		2	Ref.2	1	Spring	Ressort	Muelle
8		2	Ref.2	1	Spool	Tiroir	Cajoncillo
9		2	Ref.2	1	Spring	Ressort	Muelle
10		2	Ref.2	1	Spool	Tiroir	Cajoncillo
11		2	Ref.2	1	Stop	Butée	Tope
12		2	Ref.2	1	Plate	Plaque	Placa
13		2	Ref.2	1	Spool	Tiroir	Cajoncillo
14		2	Ref.2	1	Spring	Ressort	Muelle
15		2	Ref.2	1	Stop	Butée	Tope
16		2	Ref.2	1	Plate	Plaque	Placa
17		2	Ref.2	1	Spool	Tiroir	Cajoncillo
18		2	Ref.2	1	Spring	Ressort	Muelle
19		2	Ref.2	1	Spring	Ressort	Muelle
20		2	Ref.2	1	Spool	Tiroir	Cajoncillo
21		2	Ref.2	1	Spool	Tiroir	Cajoncillo
22		2	Ref.2	1	Spring	Ressort	Muelle
23		2	Ref.2	1	Stop	Butée	Tope
24		2	Ref.2	1	Spool	Tiroir	Cajoncillo
25		2	Ref.2	1	Spring	Ressort	Muelle
26		2	Ref.2	1	Spool	Tiroir	Cajoncillo
27		2	Ref.2	1	Stop	Butée	Tope
28		2	Ref.2	1	Plate	Plaque	Placa
29		2	Ref.2	1	Spool	Tiroir	Cajoncillo
30		2	Ref.2	1	Spring	Ressort	Muelle
31		2	Ref.2	1	Cover	Cache	Tapa
32	6193569M1	2		11	Bolt	Boulon	Perno
33	6194078M1	2		3	Plug	Bouchon	Tapón
34	6193563M1	2		3	Bolt	Boulon	Perno
35		2	Ref.2	1	Plate	Plaque	Placa
36	6193564M1	2		1	Spool	Tiroir	Cajoncillo
37	6193565M1	2		1	Spring	Ressort	Muelle
38		2	Ref.2	1	Plate	Plaque	Placa
39	6193566M1	2		6	Plug	Bouchon	Tapón
40	6193567M91	2		6	Solenoid	Solénoïde	Solenoid
41	6194079M91	2		1	Valve Assy	Ensemble de soupape	Válvula, Conj.
42		2	Ref.2	1	Clamp	Collier de serrage	Argolla de cierre
43	6193569M1	2		6	Bolt	Boulon	Perno
44	6193570M1	2		6	Tie, Cable	Attache câble	Enlace de Cable



970 980
TX970B

921 922 923 931 932

29004C13.1

6199042M3

1

Jan-06

Transmission
Transmission
Transmisión

Control Valve
Distributeur
Distribuidor de mando

Powershift
Powershift
Powershift

C-29004-13.1-A

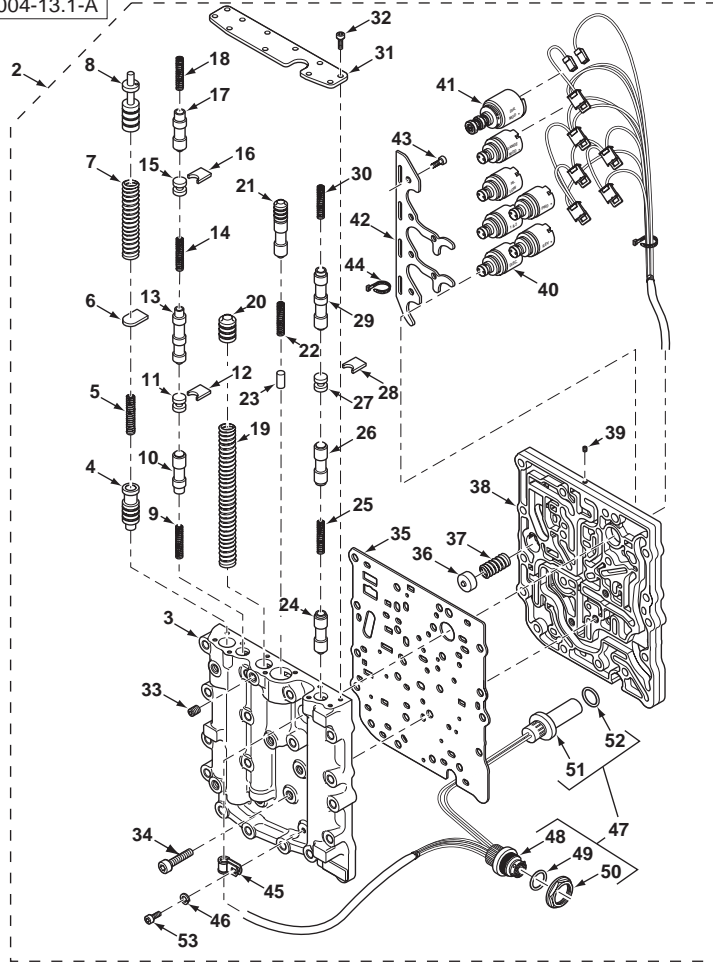

45	6193573M91	2		1	Clamp	Collier de serrage	Argolla de cierre
46	6193574M1	2		1	Washer, Lock	Rondelle de blocage	Arandela de freno
47	6194090M91	2		1	Harness Assy	Ensemble de faisceau	Haz, Conj.
48		47	➡ Ref.47	1	Harness	Faisceau	Haz
49	6193571M1	47		1	O-Ring	Joint torique	Junta de tipo O
50		47	➡ Ref.47	1	Nut	Écrou	Tuerca
51	6194080M91	47		1	Sensor	Capteur	Captador
52	6194081M1	47		1	O-Ring	Joint torique	Junta de tipo O
53	6193575M1	2		1	Bolt	Boulon	Perno



970 980
TX970B

921 922 923 931 932

29004C13.1

6199042M3

1

Jan-06

Transmission
Transmission
Transmisión

Control Valve
Distributeur
Distribuidor de mando

4 Wheel Drive
4 Roues Motrices
4 ruedas motrices

Carraro
Carraro
Carraro

C-29005-12.1-A

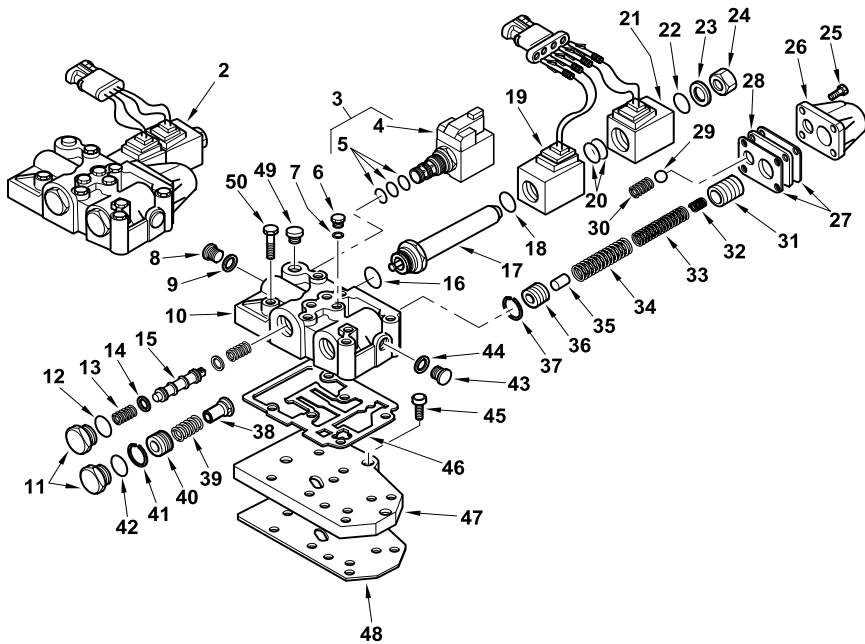

1	6110549M91		Continued	1	Gearbox	Boite de vitesses	Caja de velocidades
2	6194451M91	1		1	Valve, Control	Distributeur	Distribuidor
3	6194452M91	1		1	Valve, Solenoid	Électrovalve	Electroválvula
4		3	➡ Ref. 3	1	Valve	Soupape	Válvula
5	6194453M91	3		1	Kit, Seal	Pochette de joints	Juego de juntas
6	6194328M1	1		4	Plug	Bouchon	Tapón
7	6194329M1	1	10 x 14 x 1,5	4	Washer, Copper	Rondelle, cuivre	Arandela, cobre
8	6194454M1	1		1	Plug	Bouchon	Tapón
9	6194455M1	1		1	Washer, Copper	Rondelle, cuivre	Arandela, cobre
10	6194456M1	1		1	Body, Valve	Corps de soupape	Cuerpo de válvula
11	6194461M1	1	M26 x 1,5	2	Plug	Bouchon	Tapón
12	6194460M1	1		1	O-Ring	Joint torique	Junta de tipo O
13	6194457M1	1		2	Spring	Ressort	Muelle
14	6194458M1	1		2	Washer	Rondelle	Arandela
15	6194459M1	1		1	Spool	Tiroir	Cajoncillo
16	6194460M1	1		1	O-Ring	Joint torique	Junta de tipo O
17	6194486M1	1		1	Tube	Tube	Tubo
18	6194480M1	1		1	O-Ring	Joint torique	Junta de tipo O
19	6194483M1	1		1	Coil	Bobine	Bobina
20	6194480M1	1		2	O-Ring	Joint torique	Junta de tipo O
21	6194483M1	1		1	Coil	Bobine	Bobina
22	6194480M1	1		1	O-Ring	Joint torique	Junta de tipo O
23	6194481M1	1		1	Washer	Rondelle	Arandela
24	6194482M1	1		1	Plug	Bouchon	Tapón
25	6194478M1	1	M6 x 20	4	Bolt	Boulon	Perno
26	6194479M1	1		1	Cover, Valve	Cache-culbuteurs	Cubre válvula
27	6194476M1	1		2	Gasket	Joint	Empaquetadura
28	6194477M1	1		1	Plate	Plaque	Placa
29	6194485M1	1		1	Ball	Bille	Bola
30	6194484M1	1		1	Spring	Ressort	Muelle
31	6194475M1	1		1	Piston	Piston	Pistón
32	6194474M1	1		1	Spring	Ressort	Muelle
33	6194473M1	1		1	Spring	Ressort	Muelle
34	6194472M1	1		1	Spring	Ressort	Muelle
35	6194471M1	1	8 x 27mm	1	Pin	Axe	Pasador
36	6194470M1	1	M8 x 20	1	Piston	Piston	Pistón
37	6194487M1	1		1	Ring, Snap	Anneau d'arrêt	Anillo de resorte
38	6194465M1	1		1	Bush	Bague	Casquillo
39	6194464M1	1		1	Spring	Ressort	Muelle
40	6194463M1	1		1	Piston	Piston	Pistón
41	6194462M1	1		1	Ring, Snap	Anneau d'arrêt	Anillo de resorte
42	6194460M1	1		1	O-Ring	Joint torique	Junta de tipo O
43	6194454M1	1		1	Plug	Bouchon	Tapón
44	6194455M1	1		1	Washer, Copper	Rondelle, cuivre	Arandela, cobre



820 860 880
TX760B TX860B
TX870B

803 804 807 808 813 814 815 816 817 841 842 843 844 845

29005C12.1

6199042M3

1

Jan-06

Transmission
Transmission
Transmisión

Control Valve
Distributeur
Distribuidor de mando

4 Wheel Drive
4 Roues Motrices
4 ruedas motrices

Carraro
Carraro
Carraro

C-29005-12.1-A

45	6194469M1	1	M8 x 20	3	Bolt	Boulon	Perno
46	6194466M1	1		1	Gasket	Joint	Empaquetadura
47	6194467M1	1		1	Plate	Plaque	Placa
48	6194468M1	1		1	Gasket	Joint	Empaquetadura
49	6193381M1	1		1	Plug	Bouchon	Tapón
50	6193380M1	1	M8 x 80	6	Bolt	Boulon	Perno

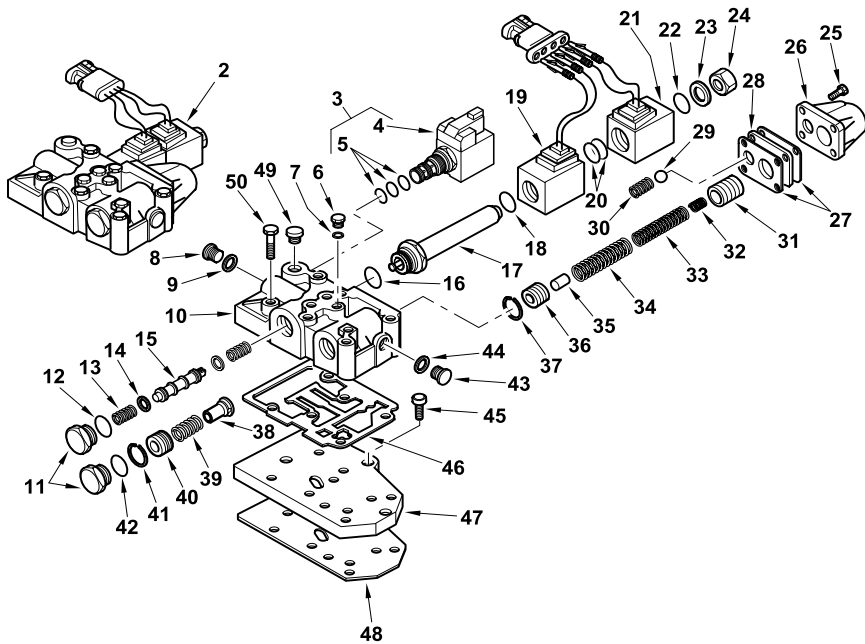

820 860 880
TX760B TX860B
TX870B

803 804 807 808 813 814 815 816 817 841 842 843 844 845

Transmission
Transmission
Transmisión

Control Valve Mounting
Support de Distributeur
Fijación del distribuidor de mando

Powershift
Powershift
Powershift

C-29003-12.1-A

1	6108875M91		Continued 2WS	1	Gearbox	Boite de vitesses	Caja de velocidades
2	6194077M91	1	👁 29003C13.1 2	1	Valve Assy, Control	Ensemble distribution	Distribuidor, Conj.
3	6193559M1	1		17	Bolt	Boulon	Perno
4	6193560M1	1		1	Seal	Joint	Junta
5	6193561M91	1		1	Cover Assy	Ensemble de couvercle	Tapa, Conj.
6		5	➡ Ref.5	1	Cover	Cache	Tapa
7	6193597M1	5		1	Breather	Reniflard	Ventilador del cárter
8	6193493M1	1		9	Bolt	Boulon	Perno

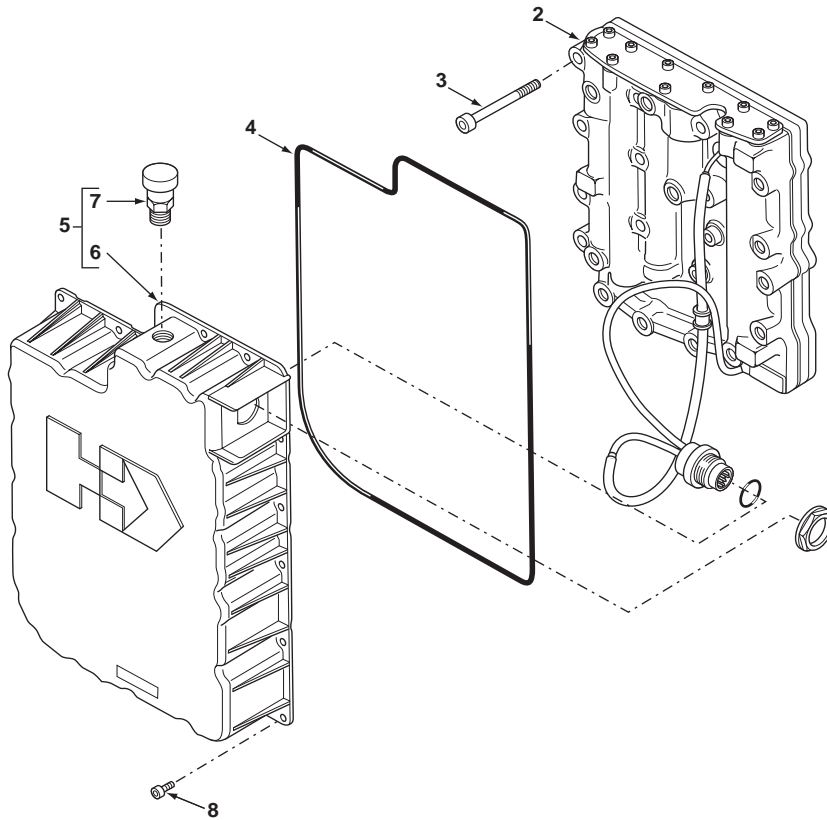

860 880
TX860B TX870B

821 822 823 824 825 851 852 853 854 855

29003C12.1

6199042M3

1

Jan-06

Transmission
Transmission
Transmisión

Control Valve Mounting
Support de Distributeur
Fijación del distribuidor de mando

Powershift
Powershift
Powershift

C-29004-12.1-A

1	6109135M91		Continued 4WS	1	Gearbox	Boite de vitesses	Caja de velocidades
2	6194077M91	1	👁 29004C13.1 2	1	Valve Assy, Control	Ensemble distribution	Distribuidor, Conj.
3	6193559M1	1		17	Bolt	Boulon	Perno
4	6193560M1	1		1	Seal	Joint	Junta
5	6193561M91	1		1	Cover Assy	Ensemble de couvercle	Tapa, Conj.
6		5	➡ Ref.5	1	Cover	Cache	Tapa
7	6193597M1	5		1	Breather	Reniflard	Ventilador del cárter
8	6193493M1	1		9	Bolt	Boulon	Perno

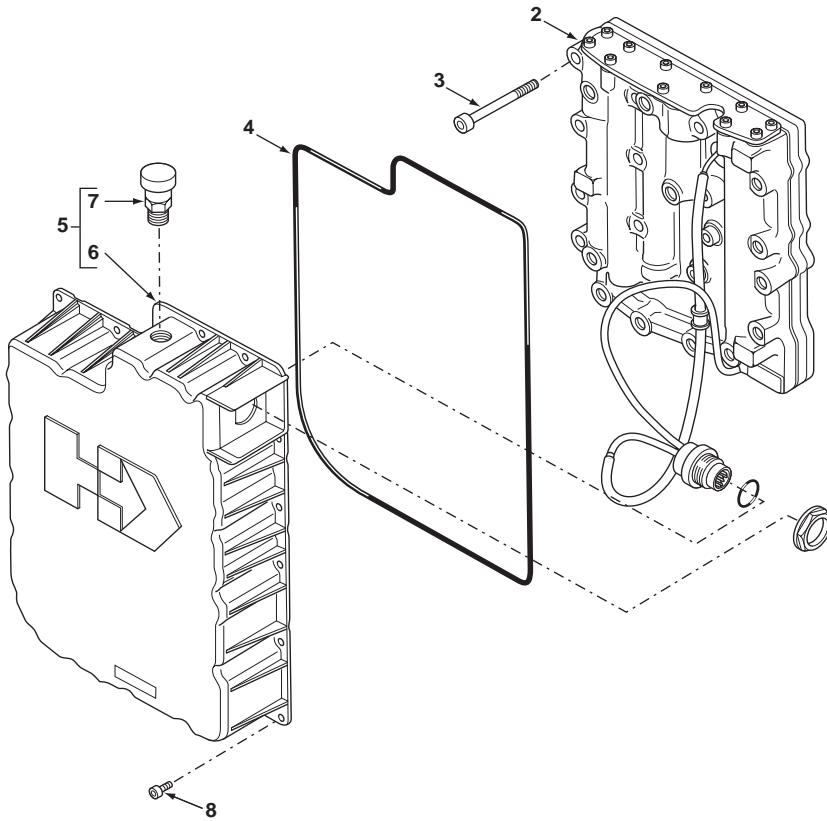

970 980
TX970B

921 922 923 931 932

29004C12.1

6199042M3

1

Jan-06

Transmission
Transmission
Transmisión

Converter Housing
Carter de Convertisseur
Cárter del convertidor

Powershift
Powershift
Powershift

C-29003-03.1-A

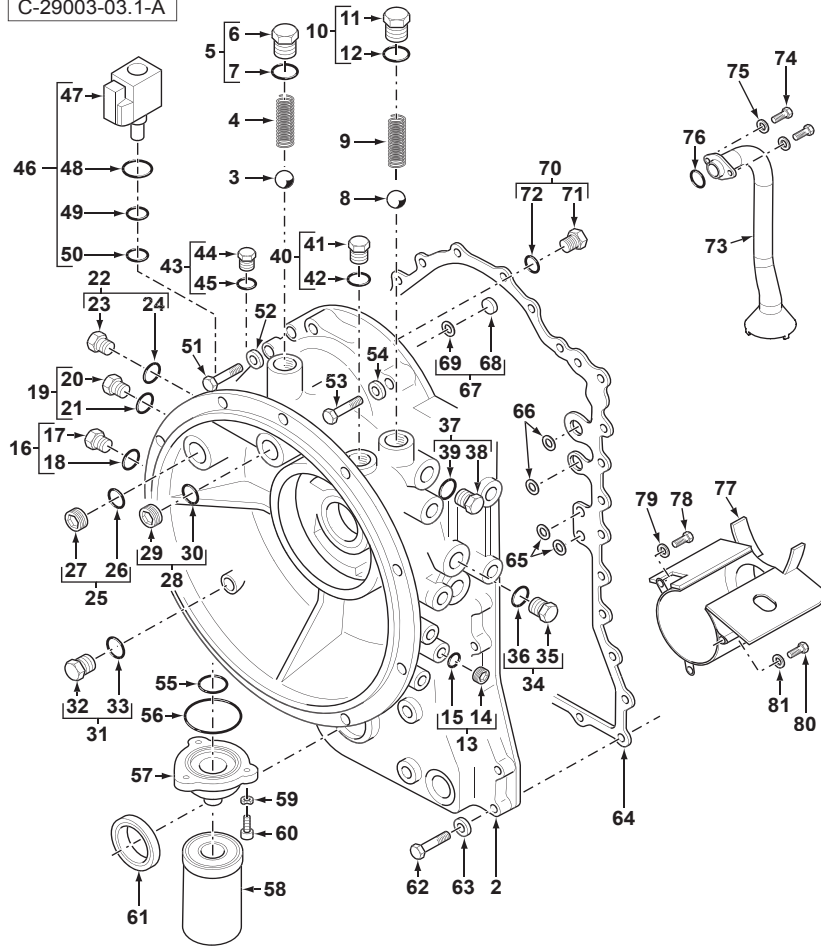

1	6108875M91		Continued 2WS	1	Gearbox	Boite de vitesses	Caja de velocidades
2	6194086M91	1		1	Housing Assy	Ensemble de carter	Cárter, Conj.
3	6193455M1	1		1	Ball	Bille	Bola
4	6193456M1	1		1	Spring	Ressort	Muelle
5	6193457M91	1		1	Plug	Bouchon	Tapón
6		5	➡ Ref.5	1	Plug	Bouchon	Tapón
7	6193587M1	5		1	O-Ring	Joint torique	Junta de tipo O
8	6193458M1	1		1	Ball	Bille	Bola
9	6193459M1	1		1	Spring	Ressort	Muelle
10	6193460M91	1		1	Plug	Bouchon	Tapón
11		12	➡ Ref.10	1	Plug	Bouchon	Tapón
12	6193588M1	12		1	O-Ring	Joint torique	Junta de tipo O
13	6193461M91	1		1	Plug	Bouchon	Tapón
14		13	➡ Ref.13	1	Plug	Bouchon	Tapón
15	6193589M1	13		1	O-Ring	Joint torique	Junta de tipo O
16	6193461M91	1		1	Plug	Bouchon	Tapón
17		16	➡ Ref.16	1	Plug	Bouchon	Tapón
18	6193589M1	16		1	O-Ring	Joint torique	Junta de tipo O
19	6193462M91	1		1	Plug	Bouchon	Tapón
20		19	➡ Ref.19	1	Plug	Bouchon	Tapón
21	6193590M1	19		1	O-Ring	Joint torique	Junta de tipo O
22	6193462M91	1		1	Plug	Bouchon	Tapón
23		22	➡ Ref.22	1	Plug	Bouchon	Tapón
24	6193590M1	22		1	O-Ring	Joint torique	Junta de tipo O
25	6193462M91	1		1	Plug	Bouchon	Tapón
26		25	➡ Ref.25	1	Plug	Bouchon	Tapón
27	6193590M1	25		1	O-Ring	Joint torique	Junta de tipo O
28	6193462M91	1		1	Plug	Bouchon	Tapón
29		28	➡ Ref.28	1	Plug	Bouchon	Tapón
30	6193590M1	28		1	O-Ring	Joint torique	Junta de tipo O
31	6193462M91	1		1	Plug	Bouchon	Tapón
32		31	➡ Ref.31	1	Plug	Bouchon	Tapón
33	6193590M1	31		1	O-Ring	Joint torique	Junta de tipo O
34	6193462M91	1		1	Plug	Bouchon	Tapón
35		34	➡ Ref.34	1	Plug	Bouchon	Tapón
36	6193590M1	34		1	O-Ring	Joint torique	Junta de tipo O
37	6193462M91	1		1	Plug	Bouchon	Tapón
38		37	➡ Ref.37	1	Plug	Bouchon	Tapón
39	6193590M1	37		1	O-Ring	Joint torique	Junta de tipo O
40	6193462M91	1		1	Plug	Bouchon	Tapón
41		40	➡ Ref.40	1	Plug	Bouchon	Tapón
42	6193590M1	40		1	O-Ring	Joint torique	Junta de tipo O
43	6193461M91	1		1	Plug	Bouchon	Tapón
44		43	➡ Ref.43	1	Plug	Bouchon	Tapón



860 880
TX860B TX870B

821 822 823 824 825 851 852 853 854 855

29003C03.1

6199042M3

1

Jan-06

Transmission
Transmission
Transmisión

Converter Housing
Carter de Convertisseur
Cárter del convertidor

Powershift
Powershift
Powershift

C-29003-03.1-A

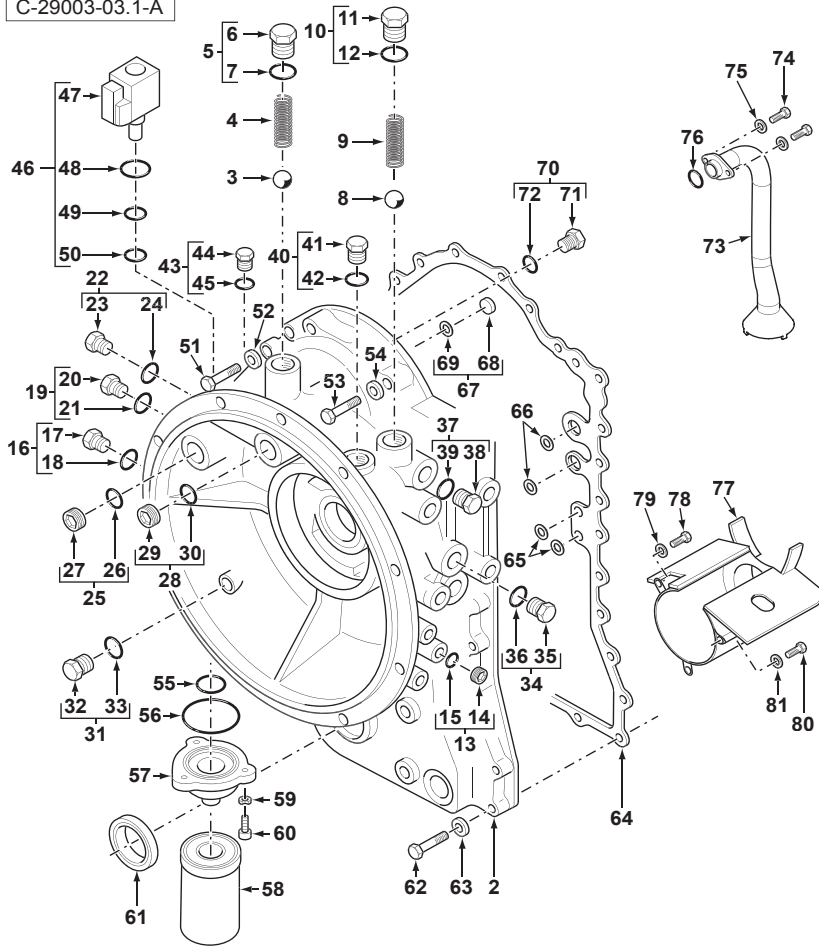

45	6193589M1	43		1	O-Ring	Joint torique	Junta de tipo O
46	6193481M91	1		1	Solenoid Assy	Ensemble de solénoïde	Solenóide, Conj.
47		46	➡ Ref.46	1	Solenoid Assy	Ensemble de solénoïde	Solenóide, Conj.
48	6193591M1	46		1	O-Ring	Joint torique	Junta de tipo O
49	6193592M1	46		1	O-Ring	Joint torique	Junta de tipo O
50	6193593M1	46		1	O-Ring	Joint torique	Junta de tipo O
51	6193487M1	1		1	Bolt	Boulon	Perno
52	6193466M1	1		2	Washer, Lock	Rondelle de blocage	Arandela de freno
53	6194044M1	1		4	Bolt	Boulon	Perno
54	6193466M1	1		4	Washer, Lock	Rondelle de blocage	Arandela de freno
55	6193463M1	1		1	O-Ring	Joint torique	Junta de tipo O
56	6193464M1	1		1	O-Ring	Joint torique	Junta de tipo O
57	6193465M1	1		1	Adaptor	Adaptateur	Adaptador
58	6194045M91	1		1	Element, Filter	Élément filtrant	Elemento filtrante
59	6193466M1	1		3	Washer, Lock	Rondelle de blocage	Arandela de freno
60	6193467M1	1		3	Bolt	Boulon	Perno
61	6193479M1	1		1	Seal	Joint	Junta
62	6194042M1	1		14	Bolt	Boulon	Perno
63	6193466M1	1		14	Washer, Lock	Rondelle de blocage	Arandela de freno
64	6194041M1	1		1	Gasket	Joint	Empaquetadura
65	6193477M1	1		2	O-Ring	Joint torique	Junta de tipo O
66	6193476M1	1		2	O-Ring	Joint torique	Junta de tipo O
67	6193462M91	1		1	Plug	Bouchon	Tapón
68		67	➡ Ref.67	1	Plug	Bouchon	Tapón
69	6193590M1	67		1	O-Ring	Joint torique	Junta de tipo O
70	6193482M91	1		1	Plug	Bouchon	Tapón
71		70	➡ Ref.70	1	Plug	Bouchon	Tapón
72	6193594M1	70		1	O-Ring	Joint torique	Junta de tipo O
73	6194040M91	1		1	Tube Assy	Tuyauterie	Conjunto de tubería
74	6193470M1	1		2	Bolt	Boulon	Perno
75	6193466M1	1		2	Washer, Lock	Rondelle de blocage	Arandela de freno
76	6193473M1	1		1	O-Ring	Joint torique	Junta de tipo O
77	6194039M91	1		1	Baffle	Chicane	Deflector
78	6193470M1	1		1	Bolt	Boulon	Perno
79	6193466M1	1		1	Washer, Lock	Rondelle de blocage	Arandela de freno
80	6193470M1	1		2	Bolt	Boulon	Perno
81	6193466M1	1		2	Washer, Lock	Rondelle de blocage	Arandela de freno



860 880
TX860B TX870B

821 822 823 824 825 851 852 853 854 855

29003C03.1

6199042M3

1

Jan-06

Transmission
Transmission
Transmisión

Converter Housing
Carter de Convertisseur
Cárter del convertidor

Powershift
Powershift
Powershift

C-29004-03.1-A

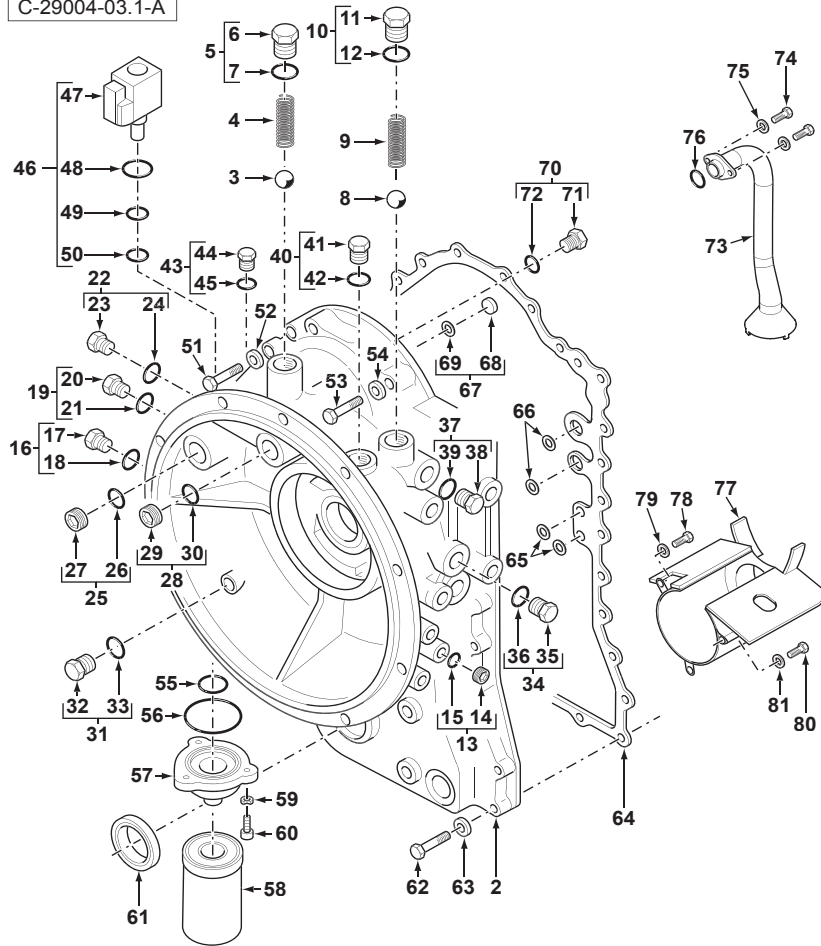

1	6109135M91		Continued 4WS	1	Gearbox	Boite de vitesses	Caja de velocidades
2	6194086M91	1		1	Housing Assy	Ensemble de carter	Cárter, Conj.
3	6193455M1	1		1	Ball	Bille	Bola
4	6193456M1	1		1	Spring	Ressort	Muelle
5	6193457M91	1		1	Plug	Bouchon	Tapón
6		5	➡ Ref.5	1	Plug	Bouchon	Tapón
7	6193587M1	5		1	O-Ring	Joint torique	Junta de tipo O
8	6193458M1	1		1	Ball	Bille	Bola
9	6193459M1	1		1	Spring	Ressort	Muelle
10	6193460M91	1		1	Plug	Bouchon	Tapón
11		12	➡ Ref.10	1	Plug	Bouchon	Tapón
12	6193588M1	12		1	O-Ring	Joint torique	Junta de tipo O
13	6193461M91	1		1	Plug	Bouchon	Tapón
14		13	➡ Ref.13	1	Plug	Bouchon	Tapón
15	6193589M1	13		1	O-Ring	Joint torique	Junta de tipo O
16	6193461M91	1		1	Plug	Bouchon	Tapón
17		16	➡ Ref.16	1	Plug	Bouchon	Tapón
18	6193589M1	16		1	O-Ring	Joint torique	Junta de tipo O
19	6193462M91	1		1	Plug	Bouchon	Tapón
20		19	➡ Ref.19	1	Plug	Bouchon	Tapón
21	6193590M1	19		1	O-Ring	Joint torique	Junta de tipo O
22	6193462M91	1		1	Plug	Bouchon	Tapón
23		22	➡ Ref.22	1	Plug	Bouchon	Tapón
24	6193590M1	22		1	O-Ring	Joint torique	Junta de tipo O
25	6193462M91	1		1	Plug	Bouchon	Tapón
26		25	➡ Ref.25	1	Plug	Bouchon	Tapón
27	6193590M1	25		1	O-Ring	Joint torique	Junta de tipo O
28	6193462M91	1		1	Plug	Bouchon	Tapón
29		28	➡ Ref.28	1	Plug	Bouchon	Tapón
30	6193590M1	28		1	O-Ring	Joint torique	Junta de tipo O
31	6193462M91	1		1	Plug	Bouchon	Tapón
32		31	➡ Ref.31	1	Plug	Bouchon	Tapón
33	6193590M1	31		1	O-Ring	Joint torique	Junta de tipo O
34	6193462M91	1		1	Plug	Bouchon	Tapón
35		34	➡ Ref.34	1	Plug	Bouchon	Tapón
36	6193590M1	34		1	O-Ring	Joint torique	Junta de tipo O
37	6193462M91	1		1	Plug	Bouchon	Tapón
38		37	➡ Ref.37	1	Plug	Bouchon	Tapón
39	6193590M1	37		1	O-Ring	Joint torique	Junta de tipo O
40	6193462M91	1		1	Plug	Bouchon	Tapón
41		40	➡ Ref.40	1	Plug	Bouchon	Tapón
42	6193590M1	40		1	O-Ring	Joint torique	Junta de tipo O
43	6193461M91	1		1	Plug	Bouchon	Tapón
44		43	➡ Ref.43	1	Plug	Bouchon	Tapón



970 980
TX970B

921 922 923 931 932

29004C03.1

6199042M3

1

Jan-06

Transmission
Transmission
Transmisión

Converter Housing
Carter de Convertisseur
Cárter del convertidor

Powershift
Powershift
Powershift

C-29004-03.1-A

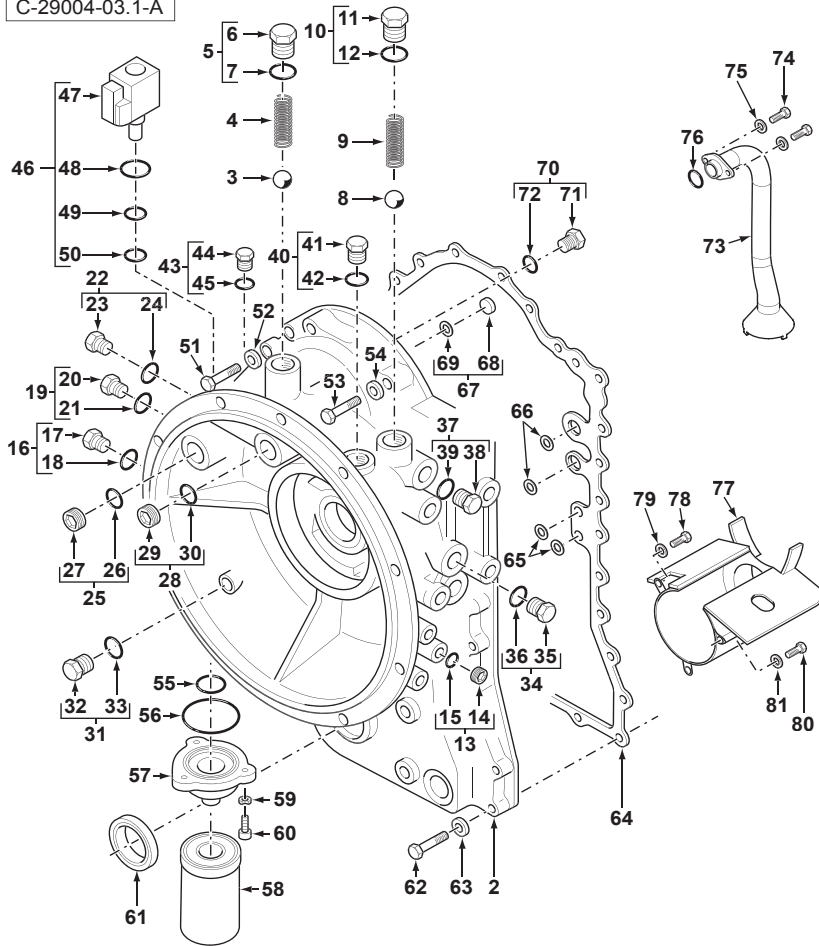

45	6193589M1	43		1	O-Ring	Joint torique	Junta de tipo O
46	6193481M91	1		1	Solenoid Assy	Ensemble de solénoïde	Solenóide, Conj.
47		46	➡ Ref.46	1	Solenoid Assy	Ensemble de solénoïde	Solenóide, Conj.
48	6193591M1	46		1	O-Ring	Joint torique	Junta de tipo O
49	6193592M1	46		1	O-Ring	Joint torique	Junta de tipo O
50	6193593M1	46		1	O-Ring	Joint torique	Junta de tipo O
51	6193487M1	1		1	Bolt	Boulon	Perno
52	6193466M1	1		2	Washer, Lock	Rondelle de blocage	Arandela de freno
53	6194044M1	1		4	Bolt	Boulon	Perno
54	6193466M1	1		4	Washer, Lock	Rondelle de blocage	Arandela de freno
55	6193463M1	1		1	O-Ring	Joint torique	Junta de tipo O
56	6193464M1	1		1	O-Ring	Joint torique	Junta de tipo O
57	6193465M1	1		1	Adaptor	Adaptateur	Adaptador
58	6194045M91	1		1	Element, Filter	Élément filtrant	Elemento filtrante
59	6193466M1	1		3	Washer, Lock	Rondelle de blocage	Arandela de freno
60	6193467M1	1		3	Bolt	Boulon	Perno
61	6193479M1	1		1	Seal	Joint	Junta
62	6194042M1	1		14	Bolt	Boulon	Perno
63	6193466M1	1		14	Washer, Lock	Rondelle de blocage	Arandela de freno
64	6194041M1	1		1	Gasket	Joint	Empaquetadura
65	6193477M1	1		2	O-Ring	Joint torique	Junta de tipo O
66	6193476M1	1		2	O-Ring	Joint torique	Junta de tipo O
67	6193462M91	1		1	Plug	Bouchon	Tapón
68		67	➡ Ref.67	1	Plug	Bouchon	Tapón
69	6193590M1	67		1	O-Ring	Joint torique	Junta de tipo O
70	6193482M91	1		1	Plug	Bouchon	Tapón
71		70	➡ Ref.70	1	Plug	Bouchon	Tapón
72	6193594M1	70		1	O-Ring	Joint torique	Junta de tipo O
73	6194040M91	1		1	Tube Assy	Tuyauterie	Conjunto de tubería
74	6193470M1	1		2	Bolt	Boulon	Perno
75	6193466M1	1		2	Washer, Lock	Rondelle de blocage	Arandela de freno
76	6193473M1	1		1	O-Ring	Joint torique	Junta de tipo O
77	6194039M91	1		1	Baffle	Chicane	Deflector
78	6193470M1	1		1	Bolt	Boulon	Perno
79	6193466M1	1		1	Washer, Lock	Rondelle de blocage	Arandela de freno
80	6193470M1	1		2	Bolt	Boulon	Perno
81	6193466M1	1		2	Washer, Lock	Rondelle de blocage	Arandela de freno



970 980
TX970B

921 922 923 931 932

29004C03.1

6199042M3

1

Jan-06

Transmission
Transmission
Transmisión

Drive Plate
Disque d'entraînement
Disco accionamiento

Powershift
Powershift
Powershift

C-29003-14.1-A

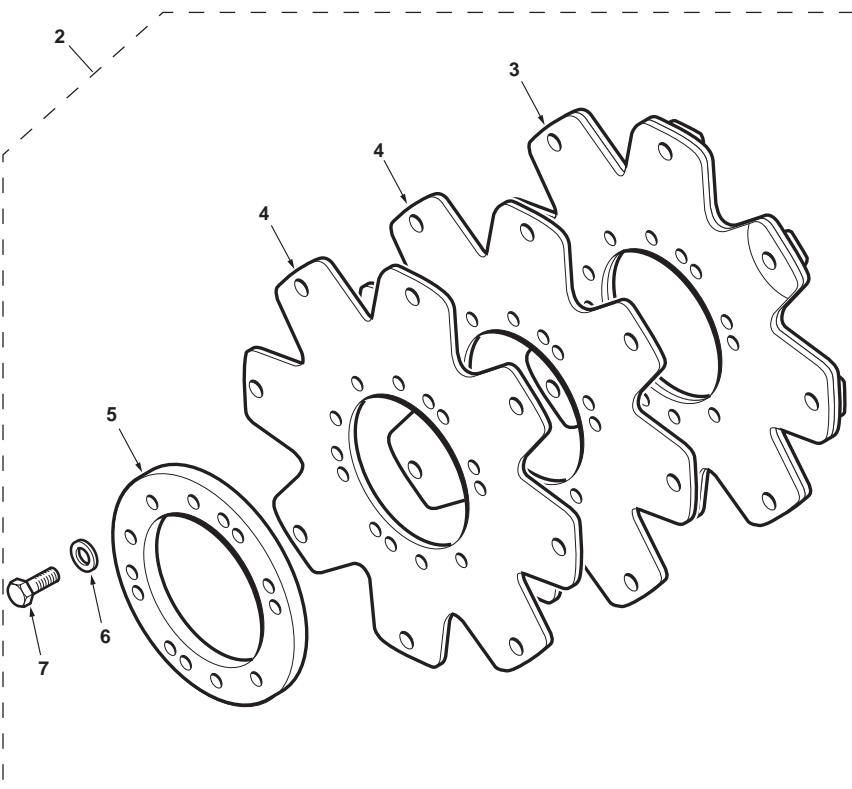

1	6108875M91		Continued 2WS	1	Gearbox	Boite de vitesses	Caja de velocidades
2	6194085M91	1		1	Kit, Parts	Lot de pièces	Juego de piezas
3		2	Ref. 2	1	Plate, Drive	Disque d'entraînement	Disco accionamiento
4		2	Ref. 2	2	Plate, Drive	Disque d'entraînement	Disco accionamiento
5	6194082M1	2		1	Ring	Anneau	Aro
6	6194083M1	2		6	Washer, Lock	Rondelle de blocage	Arandela de freno
7	6194084M1	2		6	Screw	Vis	Tornillo



860 880
TX860B TX870B

821 822 823 824 825 851 852 853 854 855

29003C14.1

6199042M3

1

Jan-06

Transmission
Transmission
Transmisión

Drive Plate
Disque d'entraînement
Disco accionamiento

Powershift
Powershift
Powershift

C-29004-14.1-A

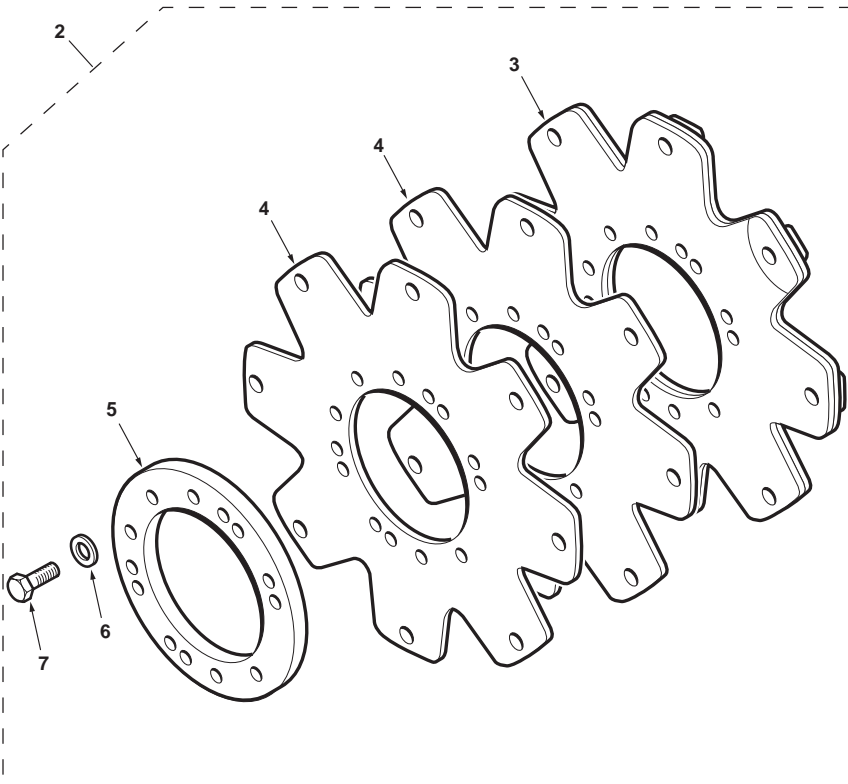

1	6109135M91		Continued 4WS	1	Gearbox	Boite de vitesses	Caja de velocidades
2	6194085M91	1		1	Kit, Parts	Lot de pièces	Juego de piezas
3		2	Ref. 2	1	Plate, Drive	Disque d'entraînement	Disco accionamiento
4		2	Ref. 2	2	Plate, Drive	Disque d'entraînement	Disco accionamiento
5	6194082M1	2		1	Ring	Anneau	Aro
6	6194083M1	2		6	Washer, Lock	Rondelle de blocage	Arandela de freno
7	6194084M1	2		6	Screw	Vis	Tornillo



970 980
TX970B

921 922 923 931 932

29004C14.1

6199042M3

1

Jan-06

Transmission
Transmission
Transmisión

Drive Shaft
Arbre d'entraînement
Árbol de arrastre

2 Wheel Drive
2 Roues Motrices
2 ruedas motrices

C-29001-02.1-A

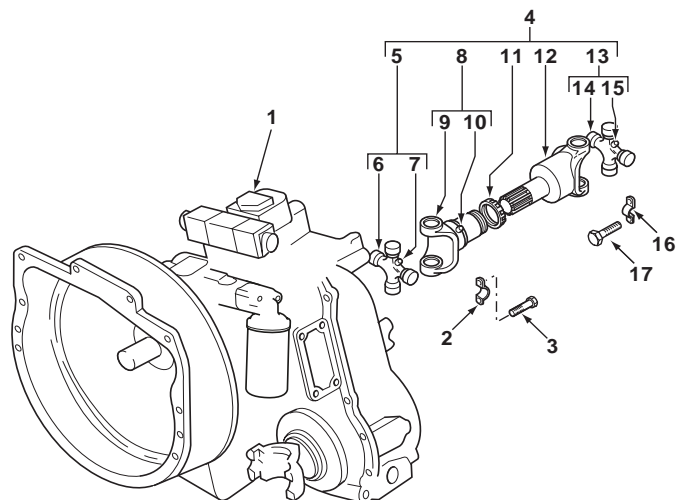

1	6109134M91		2WS	1	Gearbox	Boite de vitesses	Caja de velocidades
2	3520922M1			2	Bracket, Clamp	Bride de fixation	Brida de fijación
3	3520923M1		5/16"	4	Bolt	Boulon	Perno
4	6106483M91			1	Shaft, Drive	Arbre d'entraînement	Árbol de tracción
5	835727M91	4		1	Spider	Croisillon	Cruceta
6		5	➤ Ref. 5	1	Spider	Croisillon	Cruceta
7	13811X	5		1	Fitting, Grease	Graisneur	Engrasador
8		4	➤ Ref. 4	1	Shaft Assy	Ensemble de l'arbre	Árbol, Conj.
9		8	➤ Ref. 8	1	Shaft	Arbre	Árbol
10	13811X	8		1	Fitting, Grease	Graisneur	Engrasador
11	6190208M1	4		1	Nut	Écrou	Tuerca
12		4	➤ Ref. 4	1	Shaft	Arbre	Árbol
13	835727M91	4		1	Spider	Croisillon	Cruceta
14		13	➤ Ref. 13	1	Spider	Croisillon	Cruceta
15	13811X	13		1	Fitting, Grease	Graisneur	Engrasador
16	3520922M1			2	Bracket, Clamp	Bride de fixation	Brida de fijación
17	3520923M1		5/16"	4	Bolt	Boulon	Perno



820
TX760B TX860B
TX870B

801 802 805 806 809 810 811 812

29001C02.1

6199042M3

1

Jan-06

Transmission
Transmission
Transmisión

Drive Shaft
Arbre d'entraînement
Árbol de arrastre

4 Wheel Drive
4 Roues Motrices
4 ruedas motrices

C-29002-02.1-A

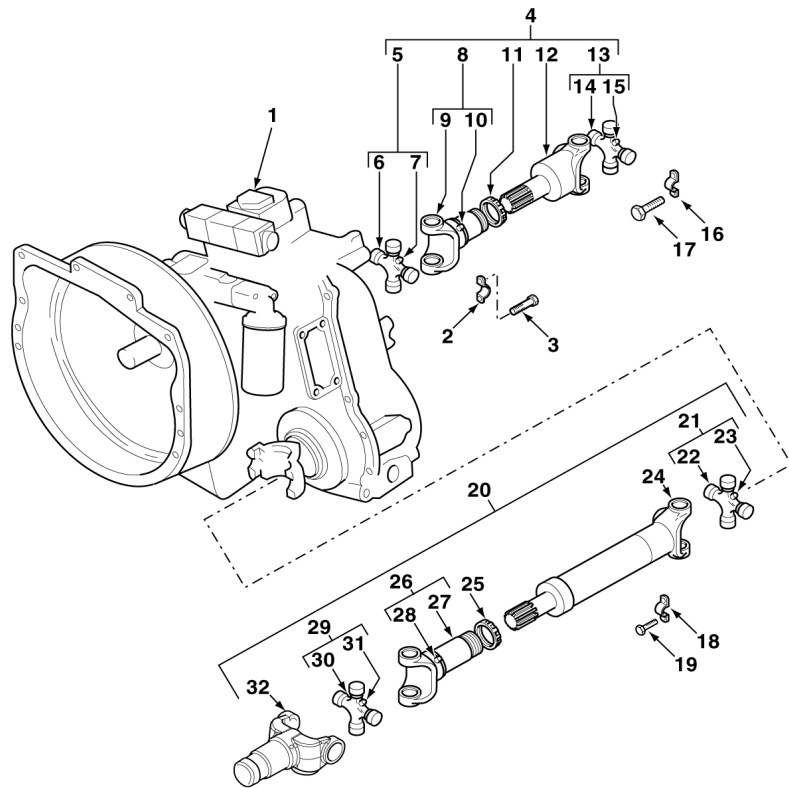

1	6108873M91		2WS	1	Gearbox	Boite de vitesses	Caja de velocidades
2	3520922M1			2	Bracket, Clamp	Bride de fixation	Brida de fijación
3	3520923M1	5/16"		4	Bolt	Boulon	Perno
4	6106483M91			1	Shaft, Drive	Arbre d'entraînement	Árbol de tracción
5	835727M91	4		1	Spider	Croisillon	Cruceta
6		5	➤ Ref. 5	1	Spider	Croisillon	Cruceta
7	13811X	5		1	Fitting, Grease	Graisneur	Engrasador
8		4	➤ Ref. 4	1	Shaft Assy	Ensemble de l'arbre	Árbol, Conj.
9		8	➤ Ref. 8	1	Shaft	Arbre	Árbol
10	13811X	8		1	Fitting, Grease	Graisneur	Engrasador
11	6190208M1	4		1	Nut	Écrou	Tuerca
12		4	➤ Ref. 4	1	Shaft	Arbre	Árbol
13	835727M91	4		1	Spider	Croisillon	Cruceta
14		13	➤ Ref. 13	1	Spider	Croisillon	Cruceta
15	13811X	13		1	Fitting, Grease	Graisneur	Engrasador
16	3520922M1			2	Bracket, Clamp	Bride de fixation	Brida de fijación
17	3520923M1	5/16"		4	Bolt	Boulon	Perno
18	3520922M1			2	Bracket, Clamp	Bride de fixation	Brida de fijación
19	3520923M1	5/16"		4	Bolt	Boulon	Perno
20	6108874M91			1	Shaft, Drive	Arbre d'entraînement	Árbol de tracción
21	835727M91	20		1	Spider	Croisillon	Cruceta
22		21	➤ Ref. 21	1	Spider	Croisillon	Cruceta
23	13811X	21		1	Fitting, Grease	Graisneur	Engrasador
24		20	➤ Ref. 20	1	Shaft	Arbre	Árbol
25		20	(A)	1	Ring	Anneau	Aro
26		20	➤ Ref. 20	1	Shaft Assy	Ensemble de l'arbre	Árbol, Conj.
27		26	➤ Ref. 26	1	Shaft	Arbre	Árbol
28	13811X	26		1	Fitting, Grease	Graisneur	Engrasador
29	835727M91	20		1	Spider	Croisillon	Cruceta
30		29	➤ Ref. 29	1	Spider	Croisillon	Cruceta
31	13811X	29		1	Fitting, Grease	Graisneur	Engrasador
32		20	(A) ➤ Ref. 20	1	Yoke	Fourche	Volea de coche

A Part number to be advised
Référence pièce à demander
Indicar número de pieza



820 860 880
TX760B TX860B
TX870B

803 804 807 808 813 814 815 816 817 831 832 833 834 841 842 843 844 845

29002C02.1

6199042M3

1

Jan-06

Transmission
Transmission
Transmisión

Drive Shaft
Arbre d'entraînement
Árbol de arrastre

2 Wheel Steer
2 Roues Directrices
Dirección en 2 ruedas

C-29003-02.1-A

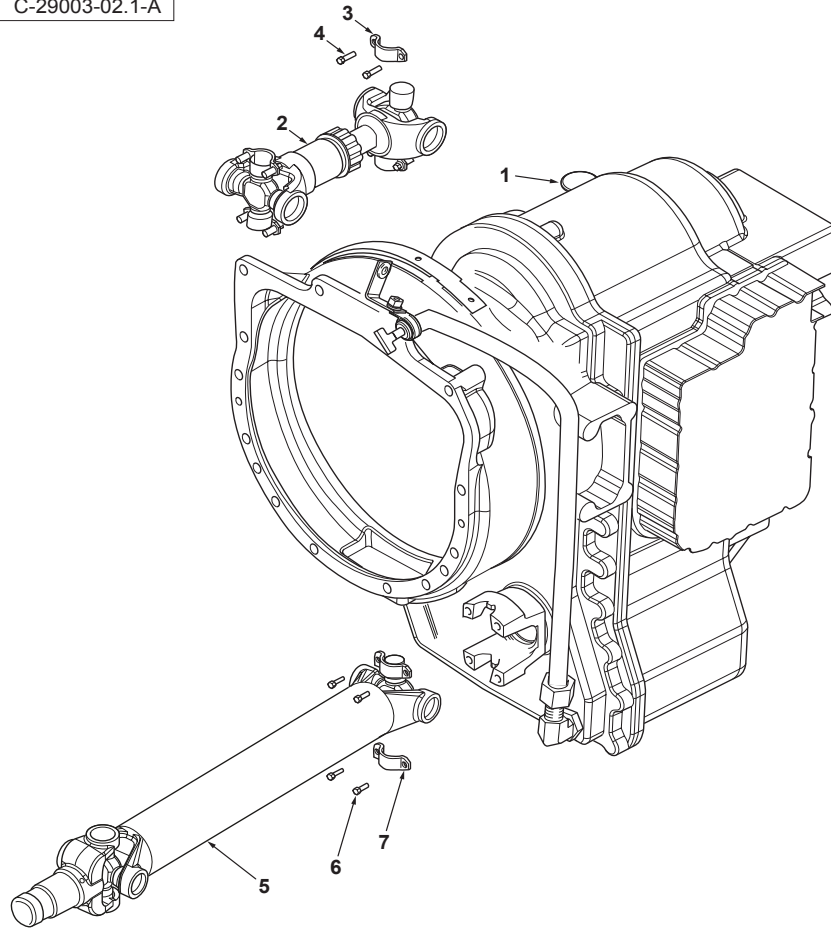

1	6108875M91	2WS	1	Gearbox	Boite de vitesses	Caja de velocidades
2	6106484M91	(A) Rear	1	Shaft, Drive	Arbre d'entraînement	Árbol de tracción
3	3520923M1	5/16"	8	Bolt	Boulon	Perno
4	3520922M1		4	Bracket, Clamp	Bride de fixation	Brida de fijación
5	6106499M91	(A) Front	1	Shaft, Drive	Arbre d'entraînement	Árbol de tracción
6	3520923M1	5/16"	4	Bolt	Boulon	Perno
7	3520922M1		2	Bracket, Clamp	Bride de fixation	Brida de fijación

A Details to be advised
Détails à demander
Detalles que deben ser notificados



860 880
TX860B TX870B

821 822 823 824 825 851 852 853 854 855

29003C02.1

6199042M3

1

Jan-06

Transmission
Transmission
Transmisión

Drive Shaft
Arbre d'entraînement
Árbol de arrastre

4 Wheel Steer
4 Roues Directrices
Dirección en las 4 ruedas

C-29004-02.1-A

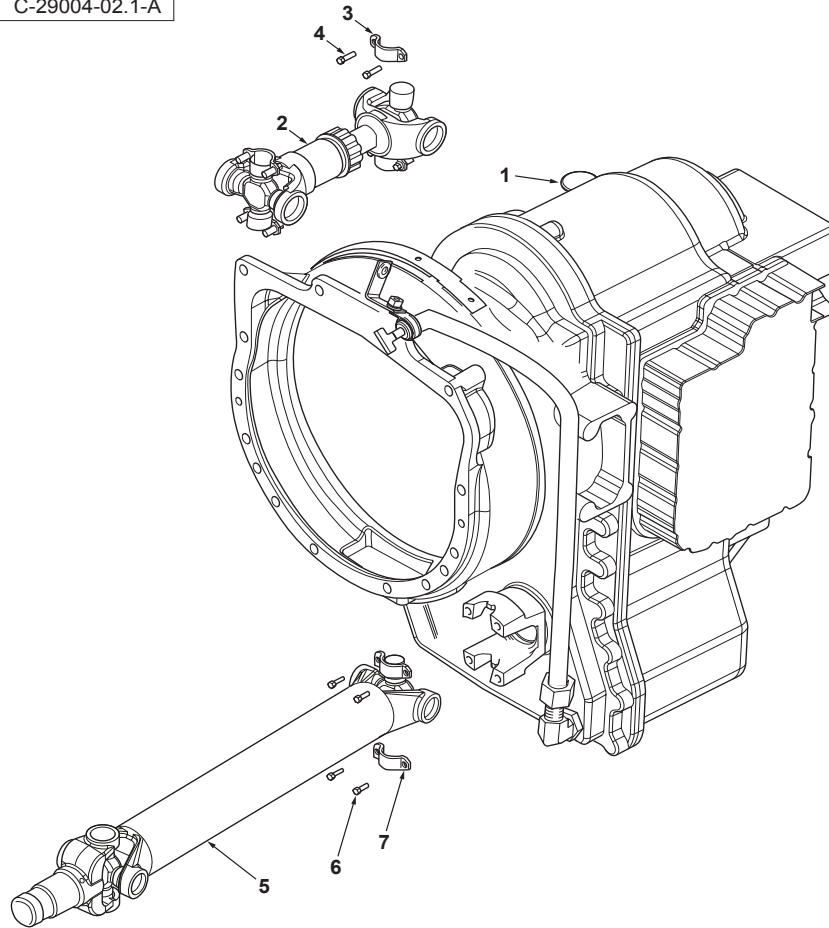

1	6109135M91		4WS	1	Gearbox	Boite de vitesses	Caja de velocidades
2	6109136M91	(A)	Rear	1	Shaft, Drive	Arbre d'entraînement	Árbol de tracción
3	3520923M1		5/16"	8	Bolt	Boulon	Perno
4	3520922M1			4	Bracket, Clamp	Bride de fixation	Brida de fijación
5	6109194M91	(A)	Front	1	Shaft, Drive	Arbre d'entraînement	Árbol de tracción
6	3520923M1		5/16"	4	Bolt	Boulon	Perno
7	3520922M1			2	Bracket, Clamp	Bride de fixation	Brida de fijación

A Details to be advised
Détails à demander
Detalles que deben ser notificados



970 980
TX970B

921 922 923 931 932

29004C02.1

6199042M3

1

Jan-06

Transmission
Transmission
Transmisión

Drive Shaft
Arbre d'entraînement
Árbol de arrastre

4 Wheel Drive
4 Roues Motrices
4 ruedas motrices

Carraro
Carraro
Carraro

C-29005-01.1-A

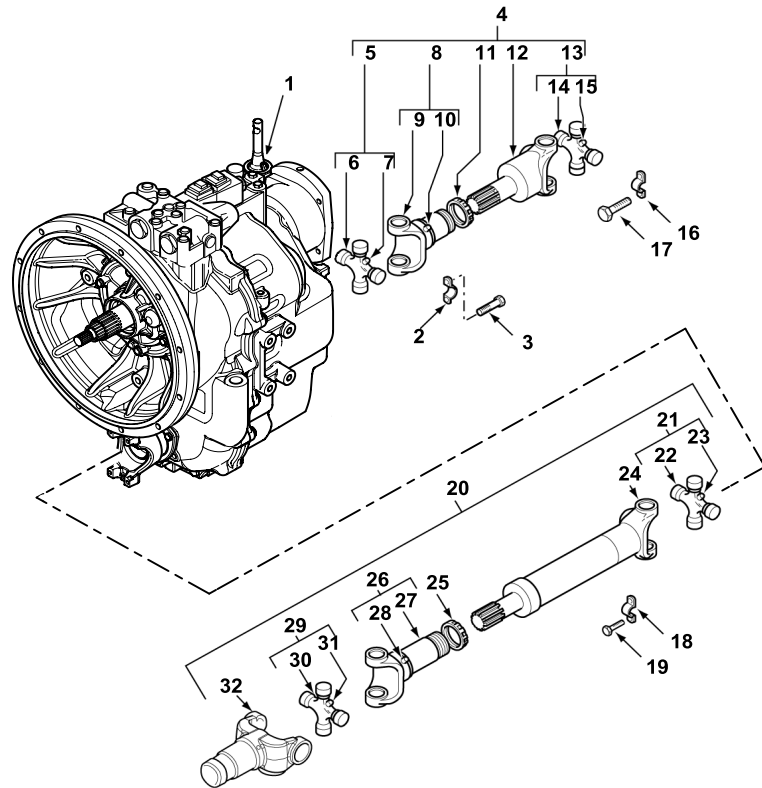

1	6110549M91			1	Gearbox	Boite de vitesses	Caja de velocidades
2	3520922M1	1		2	Bracket, Clamp	Bride de fixation	Brida de fijación
3	3520923M1	1	5/16"	4	Bolt	Boulon	Perno
4	6106483M91	1		1	Shaft, Drive	Arbre d'entraînement	Árbol de tracción
5	835727M91	4		1	Spider	Croisillon	Cruceta
6		5	▶ Ref. 5	1	Spider	Croisillon	Cruceta
7	13811X	5		1	Fitting, Grease	Graisneur	Engrasador
8		4	▶ Ref. 4	1	Shaft Assy	Ensemble de l'arbre	Árbol, Conj.
9		8	▶ Ref. 8	1	Shaft	Arbre	Árbol
10	13811X	8		1	Fitting, Grease	Graisneur	Engrasador
11	6190208M1	4		1	Nut	Écrou	Tuerca
12		4	▶ Ref. 4	1	Shaft	Arbre	Árbol
13	835727M91	4		1	Spider	Croisillon	Cruceta
14		13	▶ Ref. 13	1	Spider	Croisillon	Cruceta
15	13811X	13		1	Fitting, Grease	Graisneur	Engrasador
16	3520922M1	1		2	Bracket, Clamp	Bride de fixation	Brida de fijación
17	3520923M1	1	5/16"	4	Bolt	Boulon	Perno
18	3520922M1	1		2	Bracket, Clamp	Bride de fixation	Brida de fijación
19	3520923M1	1	5/16"	4	Bolt	Boulon	Perno
20	6106499M91	1	Front	1	Shaft, Drive	Arbre d'entraînement	Árbol de tracción
21		20	(A)	1	Spider	Croisillon	Cruceta
22		21	▶ Ref. 21	1	Spider	Croisillon	Cruceta
23	13811X	21		1	Fitting, Grease	Graisneur	Engrasador
24		20	▶ Ref. 20	1	Shaft	Arbre	Árbol
25		20	(A)	1	Ring	Anneau	Aro
26		20	▶ Ref. 20	1	Shaft Assy	Ensemble de l'arbre	Árbol, Conj.
27		26	▶ Ref. 26	1	Shaft	Arbre	Árbol
28	13811X	26		1	Fitting, Grease	Graisneur	Engrasador
29		20	(A)	1	Spider	Croisillon	Cruceta
30		29	▶ Ref. 29	1	Spider	Croisillon	Cruceta
31	13811X	29		1	Fitting, Grease	Graisneur	Engrasador
32		20	(A) ▶ Ref. 20	1	Yoke	Fourche	Volea de coche

A Part number to be advised
Référence pièce à demander
Indicar número de pieza



820 860 880
TX760B TX860B
TX870B

803 804 807 808 813 814 815 816 817 841 842 843 844 845

29005C01.1

6199042M3

1

Jan-06

Transmission
Transmission
Transmisión

Fork And Gearshift Rails
Axes et Fourchettes
Horquillas

4 Wheel Drive
4 Roues Motrices
4 ruedas motrices

Carraro
Carraro
Carraro

C-29005-11.1-A

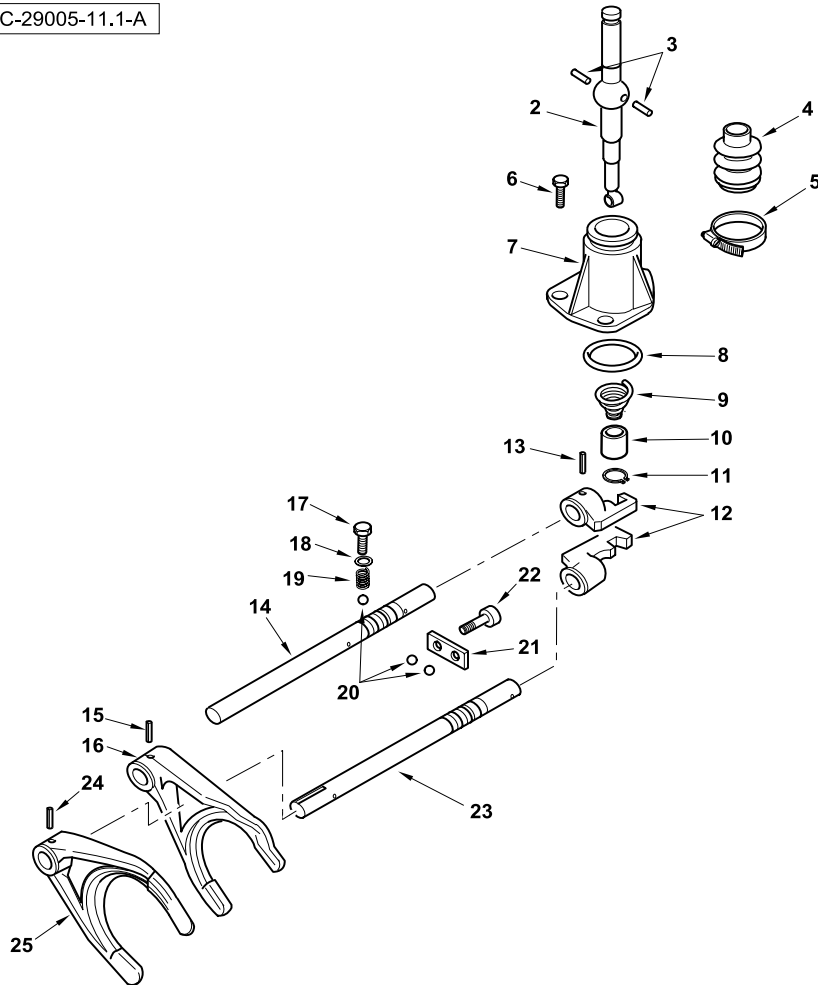

1	6110549M91		Continued	1	Gearbox	Boite de vitesses	Caja de velocidades
2	6194436M1	1		1	Lever, Control	Levier de commande	Palanca de mando
3	6194437M1	1	6 x 14 mm	2	Pin	Axe	Pasador
4	6194438M1	1		1	Boot	Soufflet	Fuelle
5	6194439M1	1		1	Clamp	Collier de serrage	Argolla de cierre
6	6194434M1	1	M8 x 25	3	Bolt	Boulon	Perno
7	6194435M1	1		1	Cover	Cache	Tapa
8	6194440M1	1		1	O-Ring	Joint torique	Junta de tipo O
9	6194441M1	1		1	Spring	Ressort	Muelle
10	6194442M1	1		1	Bush	Bague	Casquillo
11	6194443M1	1		1	Ring, Snap	Anneau d'arrêt	Anillo de resorte
12	6194444M1	1		2	Selector	Sélecteur	Selecteur
13	6194447M1	1	6 x 30 mm	2	Pin	Axe	Pasador
14	6194429M1	1		1	Rail	Rail	Carril
15	6194447M1	1	6 x 30 mm	1	Pin	Axe	Pasador
16	6194449M1	1		1	Fork, Shifter	Fourchette	Horquilla
17	6194431M1	1		2	Bolt	Boulon	Perno
18	6194430M1	1	12 x 20 x 1,5	2	Washer	Rondelle	Arandela
19	6194432M1	1		2	Spring	Ressort	Muelle
20	6194433M1	1		4	Ball	Bille	Bola
21	6194450M1	1		1	Plate	Plaque	Placa
22	6194445M1	1	M10 x 20	2	Bolt	Boulon	Perno
23	6194446M1	1		1	Rail	Rail	Carril
24	6194447M1	1	6 x 30 mm	1	Pin	Axe	Pasador
25	6194448M1	1		1	Fork, Shifter	Fourchette	Horquilla



820 860 880
TX760B TX860B
TX870B

803 804 807 808 813 814 815 816 817 841 842 843 844 845

29005C11.1

6199042M3

1

Jan-06

Transmission
Transmission
Transmisión

Fwd Low / Fwd High Shaft
Arbre Avant Inférieur / Arrière Supérieur
Árbol de marcha adelante baja/alta

Powershift
Powershift
Powershift

C-29003-07.1-A

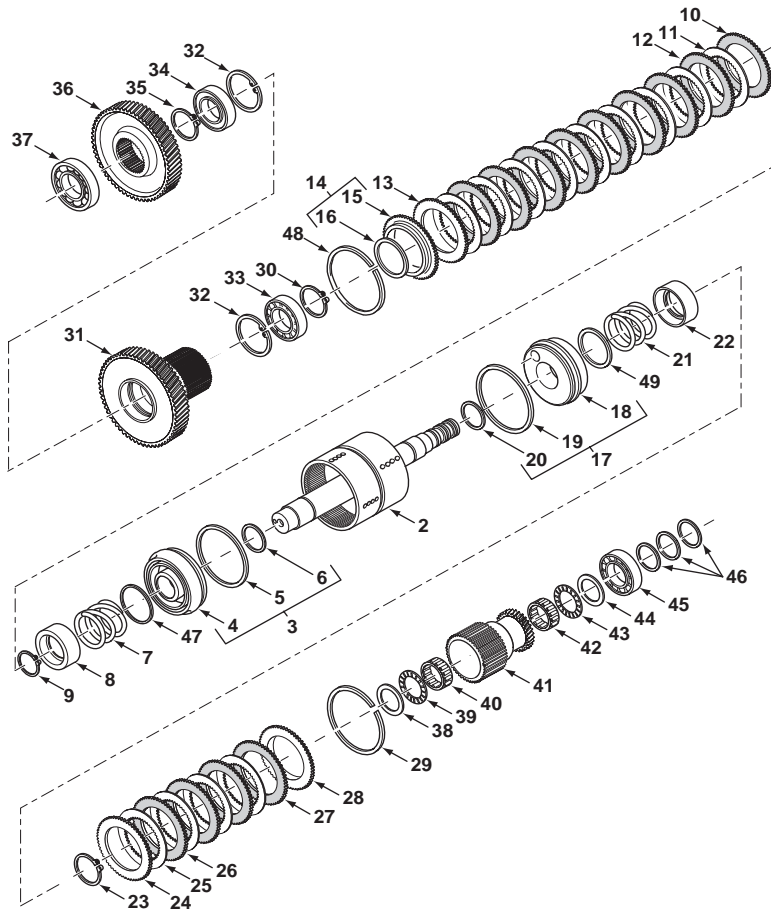

1	6108875M91		Continued 2WS	1	Gearbox	Boite de vitesses	Caja de velocidades
2	6193501M91	1		1	Shaft Assy	Ensemble de l'arbre	Árbol, Conj.
3	6193502M91	1		1	Piston Assy	Ensemble de piston	Pistón, Conj.
4		3	➡ Ref.3	1	Piston	Piston	Pistón
5	6193595M1	3		1	Seal	Joint	Junta
6	6193596M1	3		1	Seal	Joint	Junta
7	6193504M1	1		1	Spring	Ressort	Muelle
8	6193505M1	1		1	Retainer	Dispositif de retenue	Fijación
9	6193506M1	1		1	Ring, Snap	Anneau d'arrêt	Anillo de resorte
10	6193507M1	1		1	Plate, Backing	Plaque d'appui	Placa de apoyo
11	6193508M1	1		8	Disc, Friction	Disque de friction	Disco de fricción
12	6193509M1	1		7	Plate, Intermediate	Plaque intermédiaire	Placa intermediaria
13	6193507M1	1		1	Plate, Backing	Plaque d'appui	Placa de apoyo
14	6193510M1	1		1	Plate	Plaque	Placa
15		14	➡ Ref.14	1	Plate	Plaque	Placa
16	6193598M1	14		1	Seal	Joint	Junta
17	6193502M91	1		1	Piston Assy	Ensemble de piston	Pistón, Conj.
18		17	➡ Ref.17	1	Piston	Piston	Pistón
19	6193595M1	17		1	Seal	Joint	Junta
20	6193596M1	17		1	Seal	Joint	Junta
21	6193504M1	1		1	Spring	Ressort	Muelle
22	6193505M1	1		1	Retainer	Dispositif de retenue	Fijación
23	6193506M1	1		1	Ring, Snap	Anneau d'arrêt	Anillo de resorte
24	6193507M1	1		1	Plate, Backing	Plaque d'appui	Placa de apoyo
25	6193508M1	1		4	Disc, Friction	Disque de friction	Disco de fricción
26	6193509M1	1		3	Plate, Intermediate	Plaque intermédiaire	Placa intermediaria
27	6193507M1	1		1	Plate, Backing	Plaque d'appui	Placa de apoyo
28	6193512M1	1		1	Plate, Backing	Plaque d'appui	Placa de apoyo
29	6193511M1	1		1	Ring, Snap	Anneau d'arrêt	Anillo de resorte
30	6193513M1	1		1	Ring, Snap	Anneau d'arrêt	Anillo de resorte
31	6193514M1	1	54T	1	Gear	Pignon	Piñón
32	6193515M1	1		2	Ring, Snap	Anneau d'arrêt	Anillo de resorte
33	6193516M91	1		1	Bearing	Coussinet	Cojinete
34	6193517M91	1		1	Bearing	Coussinet	Cojinete
35	6193513M1	1		1	Ring, Snap	Anneau d'arrêt	Anillo de resorte
36	6193518M1	1	42T	1	Gear	Pignon	Piñón
37	6193519M91	1		1	Bearing	Coussinet	Cojinete
38	6193520M1	1		1	Spacer	Entretoise	Traviesa
39	6193521M1	1		1	Bearing, Thrust	Roulement butée	Cojinete axial
40	6193522M91	1		1	Bearing, Needle	Aiguilles de roulement	Cojinete, Agujas
41	6193523M1	1	34T	1	Gear	Pignon	Piñón
42	6193522M91	1		1	Bearing, Needle	Aiguilles de roulement	Cojinete, Agujas
43	6193521M1	1		1	Bearing, Thrust	Roulement butée	Cojinete axial
44	6193520M1	1		1	Spacer	Entretoise	Traviesa



860 880
TX860B TX870B

821 822 823 824 825 851 852 853 854 855

29003C07.1

6199042M3

1

Jan-06

Transmission
Transmission
Transmisión

Fwd Low / Fwd High Shaft
Arbre Avant Inférieur / Arrière Supérieur
Árbol de marcha adelante baja/alta

Powershift
Powershift
Powershift

C-29003-07.1-A

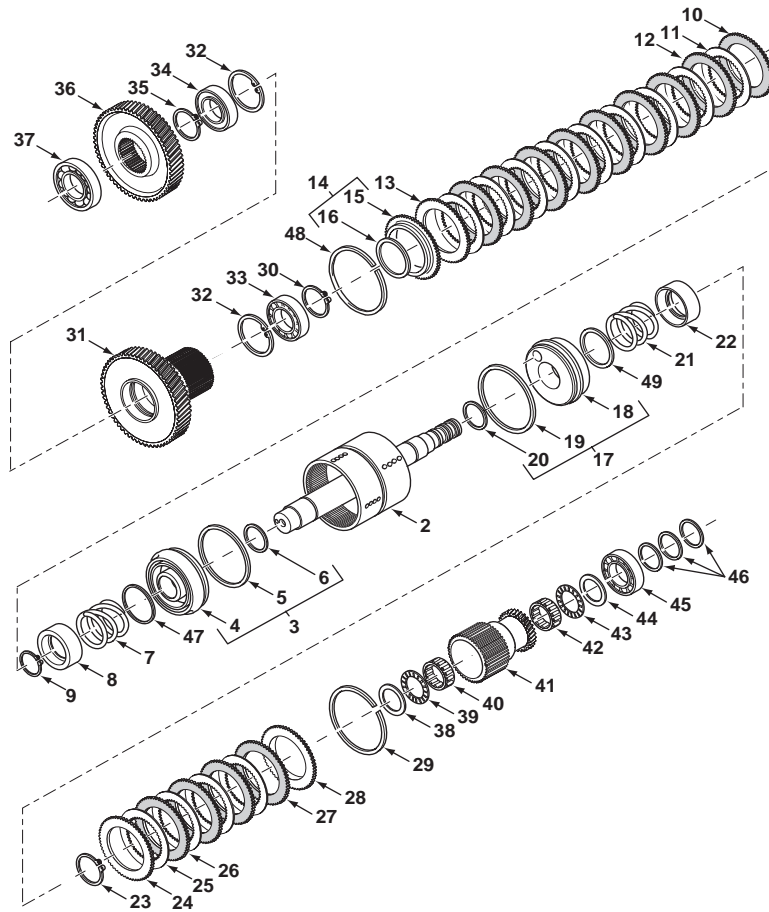

45	6193524M91	1		1	Bearing	Coussinet	Cojinete
46	6193525M1	1		3	Ring	Anneau	Aro
47	6193503M1	1		1	Plate	Plaque	Placa
48	6193511M1	1		1	Ring, Snap	Anneau d'arrêt	Anillo de resorte
49	6193503M1	1		1	Plate	Plaque	Placa



860 880
TX860B TX870B

821 822 823 824 825 851 852 853 854 855

29003C07.1

6199042M3

1

Jan-06

Transmission
Transmission
Transmisión

Fwd Low / Fwd High Shaft
Arbre Avant Inférieur / Arrière Supérieur
Árbol de marcha adelante baja/alta

Powershift
Powershift
Powershift

C-29004-07.1-A

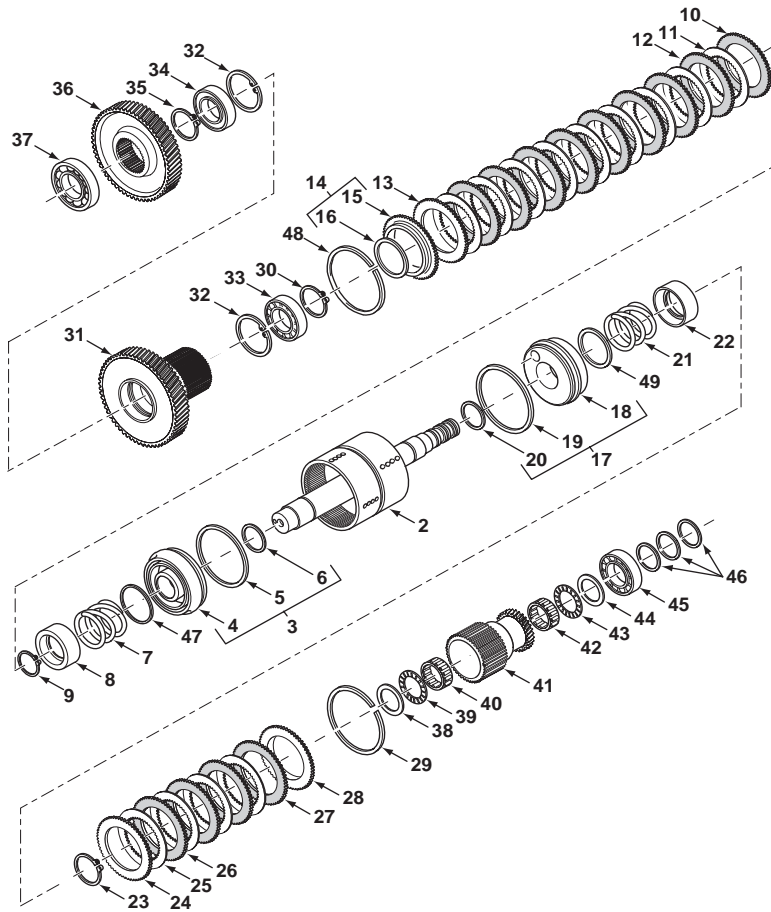

1	6109135M91		Continued 4WS	1	Gearbox	Boite de vitesses	Caja de velocidades
2	6193501M91	1		1	Shaft Assy	Ensemble de l'arbre	Árbol, Conj.
3	6193502M91	1		1	Piston Assy	Ensemble de piston	Pistón, Conj.
4		3	➡ Ref.3	1	Piston	Piston	Pistón
5	6193595M1	3		1	Seal	Joint	Junta
6	6193596M1	3		1	Seal	Joint	Junta
7	6193504M1	1		1	Spring	Ressort	Muelle
8	6193505M1	1		1	Retainer	Dispositif de retenue	Fijación
9	6193506M1	1		1	Ring, Snap	Anneau d'arrêt	Anillo de resorte
10	6193507M1	1		1	Plate, Backing	Plaque d'appui	Placa de apoyo
11	6193508M1	1		8	Disc, Friction	Disque de friction	Disco de fricción
12	6193509M1	1		7	Plate, Intermediate	Plaque intermédiaire	Placa intermediaria
13	6193507M1	1		1	Plate, Backing	Plaque d'appui	Placa de apoyo
14	6193510M1	1		1	Plate, Backing	Plaque	Placa
15		14	➡ Ref.14	1	Plate	Plaque	Placa
16	6193598M1	14		1	Seal	Joint	Junta
17	6193502M91	1		1	Piston Assy	Ensemble de piston	Pistón, Conj.
18		17	➡ Ref.17	1	Piston	Piston	Pistón
19	6193595M1	17		1	Seal	Joint	Junta
20	6193596M1	17		1	Seal	Joint	Junta
21	6193504M1	1		1	Spring	Ressort	Muelle
22	6193505M1	1		1	Retainer	Dispositif de retenue	Fijación
23	6193506M1	1		1	Ring, Snap	Anneau d'arrêt	Anillo de resorte
24	6193507M1	1		1	Plate, Backing	Plaque d'appui	Placa de apoyo
25	6193508M1	1		4	Disc, Friction	Disque de friction	Disco de fricción
26	6193509M1	1		3	Plate, Intermediate	Plaque intermédiaire	Placa intermediaria
27	6193507M1	1		1	Plate, Backing	Plaque d'appui	Placa de apoyo
28	6193512M1	1		1	Plate, Backing	Plaque d'appui	Placa de apoyo
29	6193511M1	1		1	Ring, Snap	Anneau d'arrêt	Anillo de resorte
30	6193513M1	1		1	Ring, Snap	Anneau d'arrêt	Anillo de resorte
31	6193514M1	1	54T	1	Gear	Pignon	Piñón
32	6193515M1	1		2	Ring, Snap	Anneau d'arrêt	Anillo de resorte
33	6193516M91	1		1	Bearing	Coussinet	Cojinete
34	6193517M91	1		1	Bearing	Coussinet	Cojinete
35	6193513M1	1		1	Ring, Snap	Anneau d'arrêt	Anillo de resorte
36	6193518M1	1	42T	1	Gear	Pignon	Piñón
37	6193519M91	1		1	Bearing	Coussinet	Cojinete
38	6193520M1	1		1	Spacer	Entretoise	Traviesa
39	6193521M1	1		1	Bearing, Thrust	Roulement butée	Cojinete axial
40	6193522M91	1		1	Bearing, Needle	Aiguilles de roulement	Cojinete, Agujas
41	6193523M1	1	34T	1	Gear	Pignon	Piñón
42	6193522M91	1		1	Bearing, Needle	Aiguilles de roulement	Cojinete, Agujas
43	6193521M1	1		1	Bearing, Thrust	Roulement butée	Cojinete axial
44	6193520M1	1		1	Spacer	Entretoise	Traviesa



970 980
TX970B

921 922 923 931 932

29004C07.1

6199042M3

1

Jan-06

Transmission
Transmission
Transmisión

Fwd Low / Fwd High Shaft
Arbre Avant Inférieur / Arrière Supérieur
Árbol de marcha adelante baja/alta

Powershift
Powershift
Powershift

C-29004-07.1-A

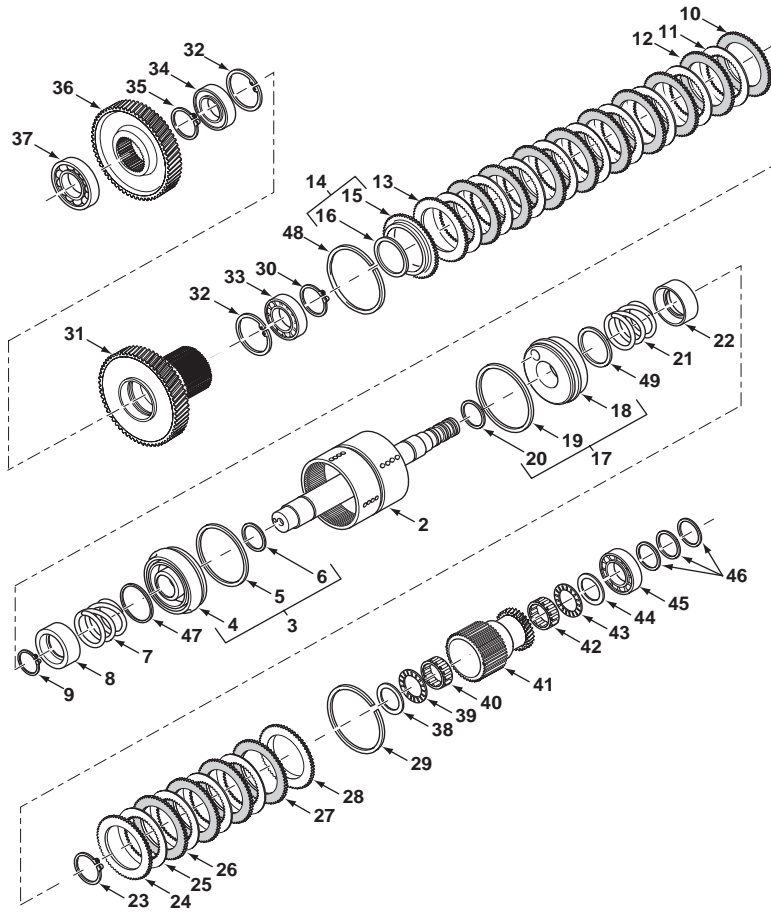

45	6193524M91	1		1	Bearing	Coussinet	Cojinete
46	6193525M1	1		3	Ring	Anneau	Aro
47	6193503M1	1		1	Plate	Plaque	Placa
48	6193511M1	1		1	Ring, Snap	Anneau d'arrêt	Anillo de resorte
49	6193503M1	1		1	Plate	Plaque	Placa



970 980
TX970B

921 922 923 931 932

29004C07.1

6199042M3

1

Jan-06

Transmission
Transmission
Transmisión

Housing
Carter
Alojamiento

2 Wheel Drive
2 Roues Motrices
2 ruedas motrices

C-29001-03.1-A

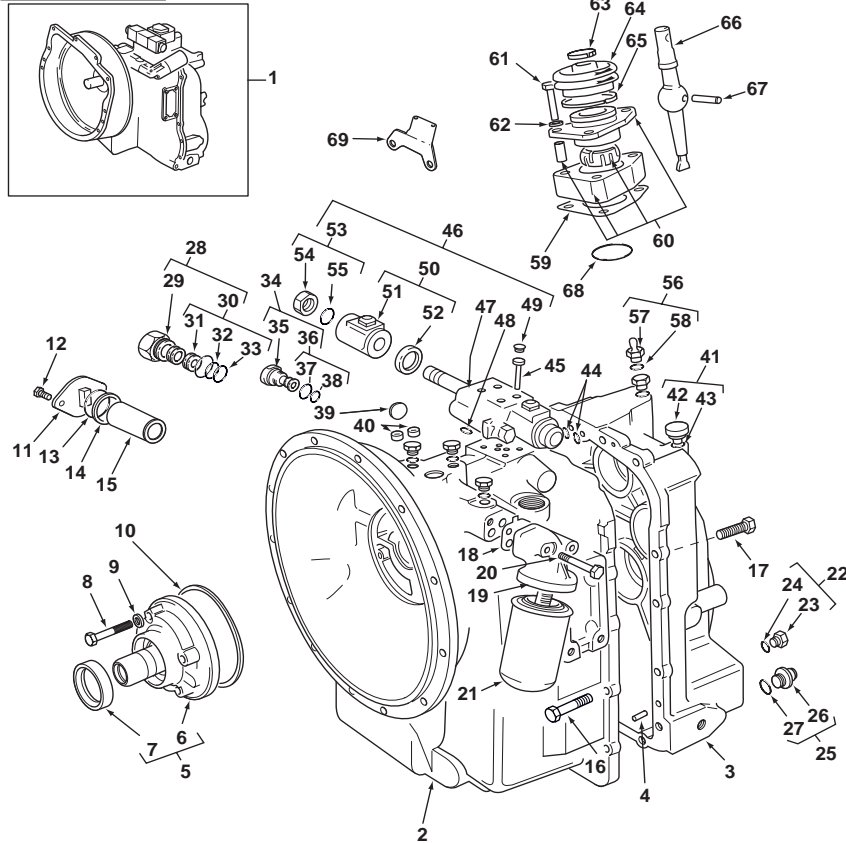

1	6109134M91		Continued 2WS	1	Gearbox	Boite de vitesses	Caja de velocidades
2	6194117M91	1		1	Housing Assy	Ensemble de carter	Cárter, Conj.
3	6194118M91	1		1	Housing Assy	Ensemble de carter	Cárter, Conj.
4	6190173M1	1		2	Pin, Dowel	Goupille position.	Peón
5	6194133M91	1		1	Pump Assy	Ensemble de pompe	Bomba, Conj.
6	6194134M91	5		1	Pump	Pompe	Bomba
7	6194135M1	5		1	Seal	Joint	Junta
8	6190847M1	1		4	Bolt	Boulon	Perno
9	6190848M1	1		4	Washer	Rondelle	Arandela
10	6190134M1	1		1	Ring, Sealing	Bague d'étanchéité	Anillo, Estanqueidad
11	6190174M91	1		1	Cover, Filter	Couvercle de filtre	Tapa de filtro
12	6190158M1	1		2	Screw	Vis	Tornillo
13	6190146M1	1		1	O-Ring	Joint torique	Junta de tipo O
14	6190092M1	1		1	Washer	Rondelle	Arandela
15	6190147M1	1		1	Strainer	Crépine	Alcachofa
16	6190012M1	1		4	Bolt	Boulon	Perno
17	6190014M1	1		13	Bolt	Boulon	Perno
18	6190045M1	1		1	Gasket	Joint	Empaquetadura
19	6190041M1	1		1	Block, Elbow	Bloc équerre	Bloque codo
20	6194147M1	1		2	Bolt	Boulon	Perno
21	6190810M1	1		1	Filter, Oil	Filtre à huile	Filtro de aceite
22	6190009M91	1		11	Plug Assy	Ensemble bouchons	Tapón, Conj.
23		22	➡ Ref. 22	1	Plug	Bouchon	Tapón
24	6190010M1	22		1	O-Ring	Joint torique	Junta de tipo O
25	6190166M91	1		1	Plug, Drain	Bouchon de vidange	Tapón de drenaje
26		25	➡ Ref. 25	1	Plug	Bouchon	Tapón
27	6190126M1	25		1	O-Ring	Joint torique	Junta de tipo O
28	6194146M91	1		1	Regulator Assy	Ensemble de régulateur	Regulador, Conj.
29		28	➡ Ref. 28	1	Valve	Soupape	Válvula
30		28 (A)		1	Kit, Parts	Lot de pièces	Juego de piezas
31		30	➡ Ref. 30	1	O-Ring	Joint torique	Junta de tipo O
32		30	➡ Ref. 30	1	O-Ring	Joint torique	Junta de tipo O
33		30	➡ Ref. 30	1	O-Ring	Joint torique	Junta de tipo O
34	6194139M91	1		1	Valve, Relief	Soupape, décharge	Válvula, Descarga
35		34	➡ Ref. 34	1	Valve	Soupape	Válvula
36		34 (A)		1	Kit, Parts	Lot de pièces	Juego de piezas
37		36	➡ Ref. 36	1	O-Ring	Joint torique	Junta de tipo O
38		36	➡ Ref. 36	1	O-Ring	Joint torique	Junta de tipo O
39	6190064M1	1		1	Plug	Bouchon	Tapón
40	6190152M1	1		2	Plug	Bouchon	Tapón
41	6190849M91	1		1	Breather Assy	Ensemble de reniflard	Ventil. cárter, Conj.
42		41	➡ Ref. 41	1	Breather	Reniflard	Ventilador del cárter
43	6190010M1	41		1	O-Ring	Joint torique	Junta de tipo O
44	6190066M1	1		3	O-Ring	Joint torique	Junta de tipo O



820
TX760B TX860B
TX870B

801 802 805 806 809 810 811 812

29001C03.1

6199042M3

1

Jan-06

Transmission
Transmission
Transmisión

Housing
Carter
Alojamiento

2 Wheel Drive
2 Roues Motrices
2 ruedas motrices

C-29001-03.1-A

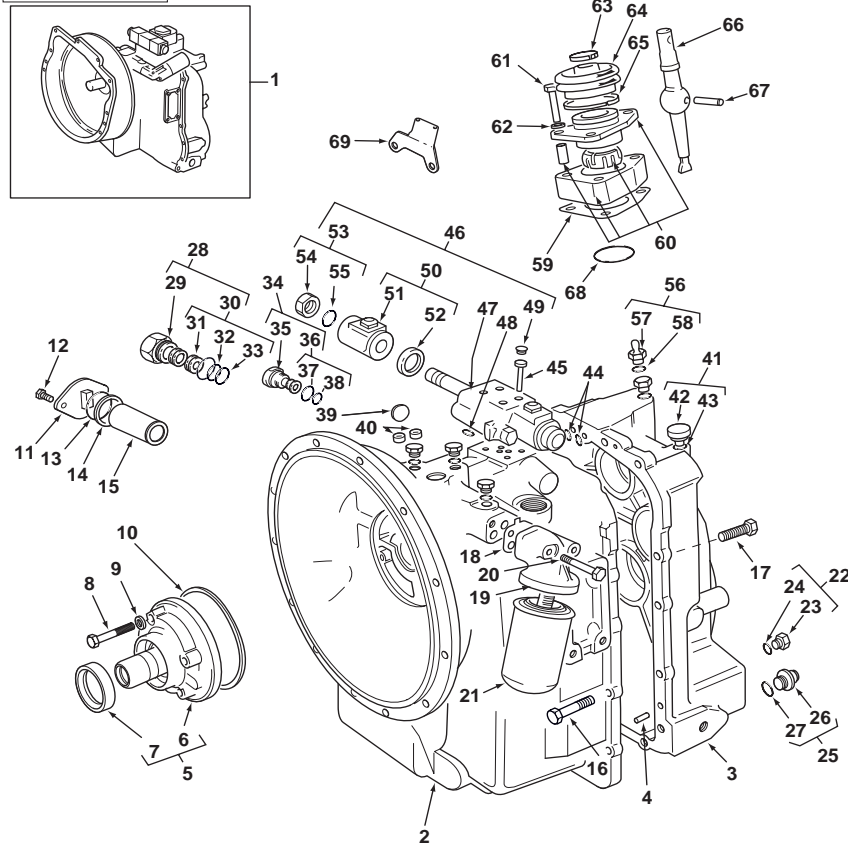

45	6190553M1	1		4	Screw	Vis	Tornillo
46	6190820M91	1		1	Valve, Solenoid	Électrovalve	Electroválvula
47		46	➡ Ref. 46	1	Body	Corps	Cuerpo
48	6190399M1	46		4	O-Ring	Joint torique	Junta de tipo O
49	6190360M1	46	Plastic	4	Plug	Bouchon	Tapón
50	6190568M91	46		2	Solenoid Assy	Ensemble de solénoïde	Solenóide, Conj.
51		50	➡ Ref. 50	1	Solenoid	Solénoïde	Solenóide
52	6190822M1	50	Rubber	1	Washer	Rondelle	Arandela
53	6190569M91	46		1	Kit, Service	Kit d'entretien	Juego de servicio
54		53	➡ Ref. 53	1	Nut	Écrou	Tuerca
55		53	➡ Ref. 53	1	O-Ring	Joint torique	Junta de tipo O
56	6190235M1	1		1	Plug Assy	Ensemble bouchons	Tapón, Conj.
57		56	➡ Ref. 56	1	Plug	Bouchon	Tapón
58	6190010M1	56		1	O-Ring	Joint torique	Junta de tipo O
59	6190824M1	1		1	Gasket	Joint	Empaquetadura
60	6190143M91	1		1	Seating	Siège	Asiento
61	6190013M1	1		3	Bolt	Boulon	Perno
62	6190044M1	1		3	Washer	Rondelle	Arandela
63	6194138M1	1		1	Clip	Clip	Clip
64	6190145M1	1		1	Boot	Soufflet	Fuelle
65	6194137M1	1		1	Clip	Clip	Clip
66	6190142M1	1		1	Lever	Levier	Palanca
67	6190144M1	1		1	Pin	Axe	Pasador
68	6190823M1	1		1	O-Ring	Joint torique	Junta de tipo O
69	6108806M1	1		1	Angle Plate	Coin	Angulo

A Part number to be advised
Référence pièce à demander
Indicar número de pieza



801 802 805 806 809 810 811 812

29001C03.1

6199042M3

1

Jan-06

Transmission
Transmission
Transmisión

Housing
Carter
Alojamiento

4 Wheel Drive
4 Roues Motrices
4 ruedas motrices

C-29002-03.1-A

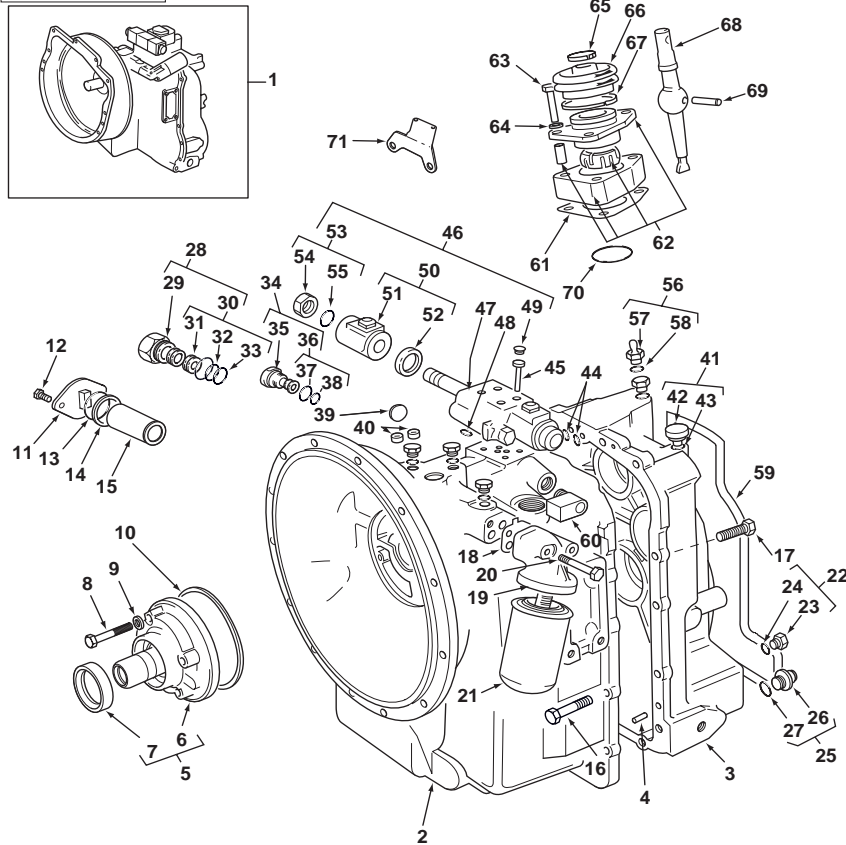

1	6108873M91		Continued 2WS	1	Gearbox	Boite de vitesses	Caja de velocidades
2	6194148M91	1		1	Housing Assy	Ensemble de carter	Cárter, Conj.
3	6194149M91	1		1	Housing Assy	Ensemble de carter	Cárter, Conj.
4	6190173M1	1		2	Pin, Dowel	Goupille position.	Peón
5	6194133M91	1		1	Pump Assy	Ensemble de pompe	Bomba, Conj.
6	6194134M91	5		1	Pump	Pompe	Bomba
7	6194135M1	5		1	Seal	Joint	Junta
8	6190847M1	1		4	Bolt	Boulon	Perno
9	6190848M1	1		4	Washer	Rondelle	Arandela
10	6190134M1	1		1	Ring, Sealing	Bague d'étanchéité	Anillo, Estanqueidad
11	6190174M91	1		1	Cover, Filter	Couvercle de filtre	Tapa de filtro
12	6190158M1	1		2	Screw	Vis	Tornillo
13	6190146M1	1		1	O-Ring	Joint torique	Junta de tipo O
14	6190092M1	1		1	Washer	Rondelle	Arandela
15	6190147M1	1		1	Strainer	Crépine	Alcachofa
16	6190012M1	1		4	Bolt	Boulon	Perno
17	6190014M1	1		13	Bolt	Boulon	Perno
18	6190045M1	1		1	Gasket	Joint	Empaquetadura
19	6190041M1	1		1	Block, Elbow	Bloc équerre	Bloque codo
20	6194147M1	1		2	Bolt	Boulon	Perno
21	6190810M1	1		1	Filter, Oil	Filtre à huile	Filtro de aceite
22	6190009M91	1		11	Plug Assy	Ensemble bouchons	Tapón, Conj.
23		22	➡ Ref. 22	1	Plug	Bouchon	Tapón
24	6190010M1	22		1	O-Ring	Joint torique	Junta de tipo O
25	6190166M91	1		1	Plug, Drain	Bouchon de vidange	Tapón de drenaje
26		25	➡ Ref. 25	1	Plug	Bouchon	Tapón
27	6190126M1	25		1	O-Ring	Joint torique	Junta de tipo O
28	6194146M91	1		1	Regulator Assy	Ensemble de régulateur	Regulador, Conj.
29		28	➡ Ref. 28	1	Valve	Soupape	Válvula
30		28 (A)		1	Kit, Parts	Lot de pièces	Juego de piezas
31		30	➡ Ref. 30	1	O-Ring	Joint torique	Junta de tipo O
32		30	➡ Ref. 30	1	O-Ring	Joint torique	Junta de tipo O
33		30	➡ Ref. 30	1	O-Ring	Joint torique	Junta de tipo O
34	6194139M91	1		1	Valve, Relief	Soupape, décharge	Válvula, Descarga
35		34	➡ Ref. 34	1	Valve	Soupape	Válvula
36		34 (A)		1	Kit, Parts	Lot de pièces	Juego de piezas
37		36	➡ Ref. 36	1	O-Ring	Joint torique	Junta de tipo O
38		36	➡ Ref. 36	1	O-Ring	Joint torique	Junta de tipo O
39	6190064M1	1		1	Plug	Bouchon	Tapón
40	6190152M1	1		2	Plug	Bouchon	Tapón
41	6190849M91	1		1	Breather Assy	Ensemble de reniflard	Ventil. cárter, Conj.
42		41	➡ Ref. 41	1	Breather	Reniflard	Ventilador del cárter
43	6190010M1	41		1	O-Ring	Joint torique	Junta de tipo O
44	6190066M1	1		3	O-Ring	Joint torique	Junta de tipo O



820 860 880
TX760B TX860B
TX870B

803 804 807 808 813 814 815 816 817 831 832 833 834 841 842 843 844 845

29002C03.1

6199042M3

1

Jan-06

Transmission
Transmission
Transmisión

Housing
Carter
Alojamiento

4 Wheel Drive
4 Roues Motrices
4 ruedas motrices

C-29002-03.1-A

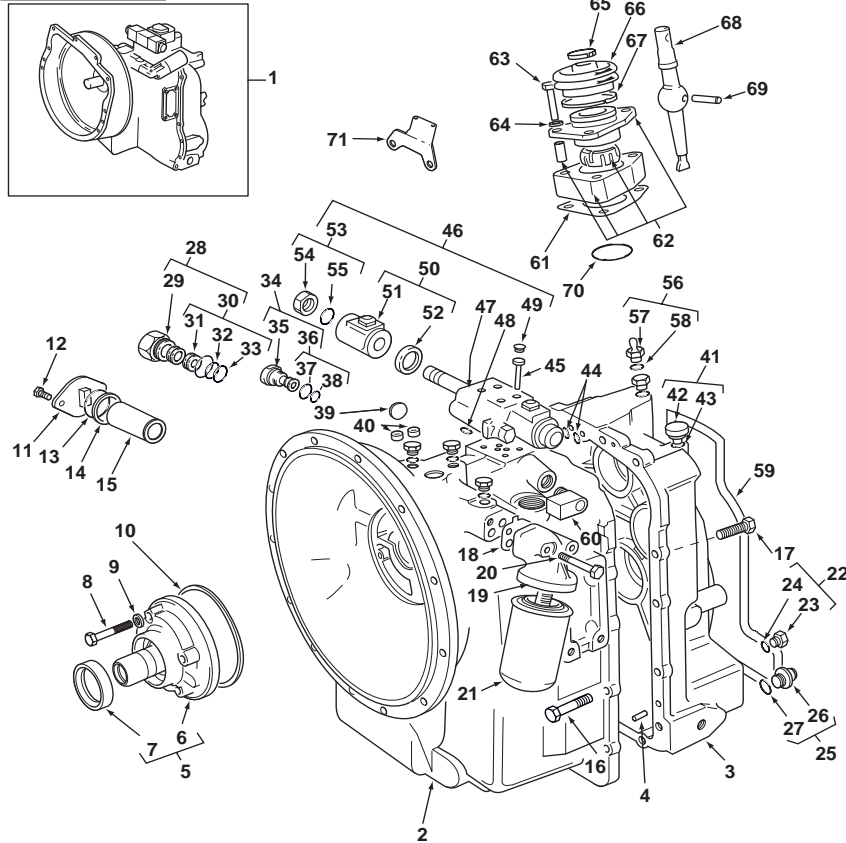

45	6190553M1	1		4	Screw	Vis	Tornillo
46	6190820M91	1		1	Valve, Solenoid	Électrovalve	Electroválvula
47		46	➡ Ref. 46	1	Body	Corps	Cuerpo
48	6190399M1	46		4	O-Ring	Joint torique	Junta de tipo O
49	6190360M1	46	Plastic	4	Plug	Bouchon	Tapón
50	6190568M91	46		2	Solenoid Assy	Ensemble de solénoïde	Solenóide, Conj.
51		50	➡ Ref. 50	1	Solenoid	Solénoïde	Solenóide
52	6190822M1	50	Rubber	1	Washer	Rondelle	Arandela
53	6190569M91	46		1	Kit, Service	Kit d'entretien	Juego de servicio
54		53	➡ Ref. 53	1	Nut	Écrou	Tuerca
55		53	➡ Ref. 53	1	O-Ring	Joint torique	Junta de tipo O
56	6190235M1	1		1	Plug Assy	Ensemble bouchons	Tapón, Conj.
57		56	➡ Ref. 56	1	Plug	Bouchon	Tapón
58	6190010M1	56		1	O-Ring	Joint torique	Junta de tipo O
59	6194150M91	1		1	Tube Assy	Tuyauterie	Conjunto de tubería
60	6190172M91	1		1	Valve	Soupape	Válvula
61	6190824M1	1		1	Gasket	Joint	Empaquetadura
62	6190143M91	1		1	Seating	Siège	Asiento
63	6190013M1	1		3	Bolt	Boulon	Perno
64	6190044M1	1		3	Washer	Rondelle	Arandela
65	6194138M1	1		1	Clip	Clip	Clip
66	6190145M1	1		1	Boot	Soufflet	Fuelle
67	6194137M1	1		1	Clip	Clip	Clip
68	6190142M1	1		1	Lever	Levier	Palanca
69	6190144M1	1		1	Pin	Axe	Pasador
70	6190823M1	1		1	O-Ring	Joint torique	Junta de tipo O
71	6108806M1	1		1	Angle Plate	Coin	Angulo

A Part number to be advised
Référence pièce à demander
Indicar número de pieza



820 860 880
TX760B TX860B
TX870B

803 804 807 808 813 814 815 816 817 831 832 833 834 841 842 843 844 845

29002C03.1

6199042M3

1

Jan-06

Transmission
Transmission
Transmisión

Housing
Carter
Alojamiento

Powershift
Powershift
Powershift

C-29003-04.1-A

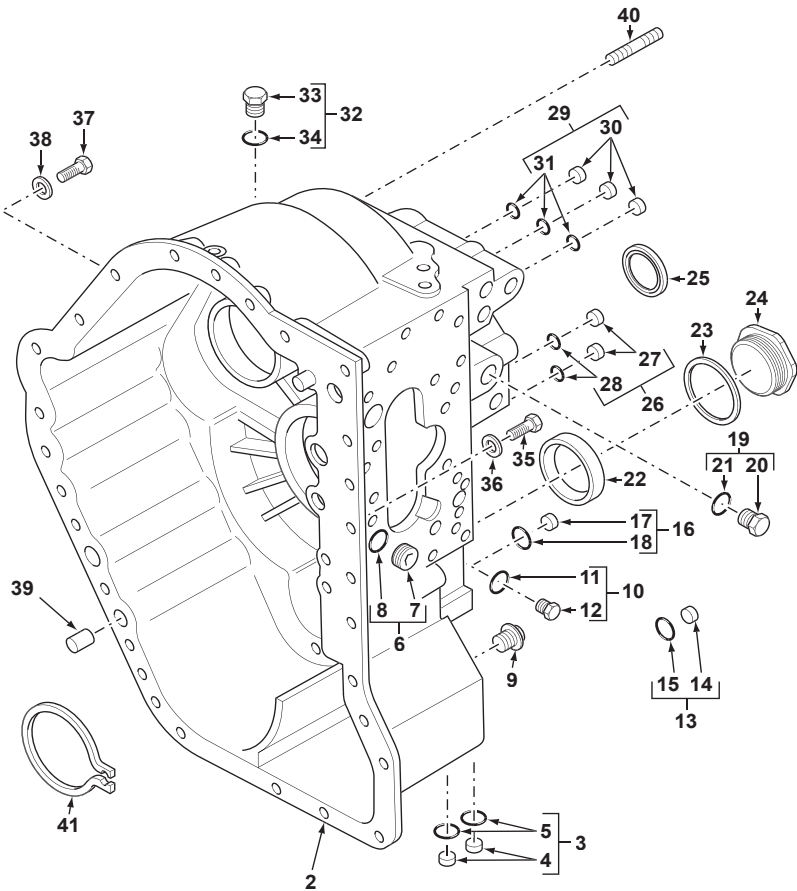

1	6108875M91		Continued 2WS	1	Gearbox	Boite de vitesses	Caja de velocidades
2	6194046M91	1		1	Housing Assy	Ensemble de carter	Cárter, Conj.
3	6193461M91	1		2	Plug	Bouchon	Tapón
4		3	➡ Ref. 3	1	Plug	Bouchon	Tapón
5	6193589M1	3		1	O-Ring	Joint torique	Junta de tipo O
6	6193461M91	1		1	Plug	Bouchon	Tapón
7		6	➡ Ref. 6	1	Plug	Bouchon	Tapón
8	6193589M1	6		1	O-Ring	Joint torique	Junta de tipo O
9	6193485M91	1		1	Plug	Bouchon	Tapón
10	6193461M91	1		1	Plug	Bouchon	Tapón
11		10	➡ Ref. 10	1	Plug	Bouchon	Tapón
12	6193589M1	10		1	O-Ring	Joint torique	Junta de tipo O
13	6193461M91	1		1	Plug	Bouchon	Tapón
14		13	➡ Ref. 13	1	Plug	Bouchon	Tapón
15	6193589M1	13		1	O-Ring	Joint torique	Junta de tipo O
16	6193461M91	1		1	Plug	Bouchon	Tapón
17		16	➡ Ref. 16	1	Plug	Bouchon	Tapón
18	6193589M1	16		1	O-Ring	Joint torique	Junta de tipo O
19	6194048M91	1		1	Plug Assy	Ensemble bouchons	Tapón, Conj.
20		19	➡ Ref. 19	1	Plug	Bouchon	Tapón
21	6194047M1	19		1	O-Ring	Joint torique	Junta de tipo O
22	6194052M1	1		1	Plug	Bouchon	Tapón
23	6194050M1	1		1	Seal	Joint	Junta
24	6194051M1	1		1	Plug	Bouchon	Tapón
25	6193479M1	1		1	Seal	Joint	Junta
26	6193461M91	1		2	Plug	Bouchon	Tapón
27		26	➡ Ref. 26	1	Plug	Bouchon	Tapón
28	6193589M1	26		1	O-Ring	Joint torique	Junta de tipo O
29	6193461M91	1		3	Plug	Bouchon	Tapón
30		29	➡ Ref. 29	1	Plug	Bouchon	Tapón
31	6193589M1	29		1	O-Ring	Joint torique	Junta de tipo O
32	6193462M91	1		1	Plug	Bouchon	Tapón
33		32	➡ Ref. 32	1	Plug	Bouchon	Tapón
34	6193590M1	32		1	O-Ring	Joint torique	Junta de tipo O
35	6194053M1	1		2	Bolt	Boulon	Perno
36	6193466M1	1		2	Washer, Lock	Rondelle de blocage	Arandela de freno
37	6193487M1	1		7	Bolt	Boulon	Perno
38	6193466M1	1		7	Washer, Lock	Rondelle de blocage	Arandela de freno
39	6193484M1	1		2	Pin	Axe	Pasador
40	6194054M1	1		4	Stud	Goujon	Espárrago
41	6194049M1	1		1	Ring, Snap	Anneau d'arrêt	Anillo de resorte



860 880
TX860B TX870B

821 822 823 824 825 851 852 853 854 855

29003C04.1

6199042M3

1

Jan-06

Transmission
Transmission
Transmisión

Housing
Carter
Alojamiento

Powershift
Powershift
Powershift

C-29004-04.1-A

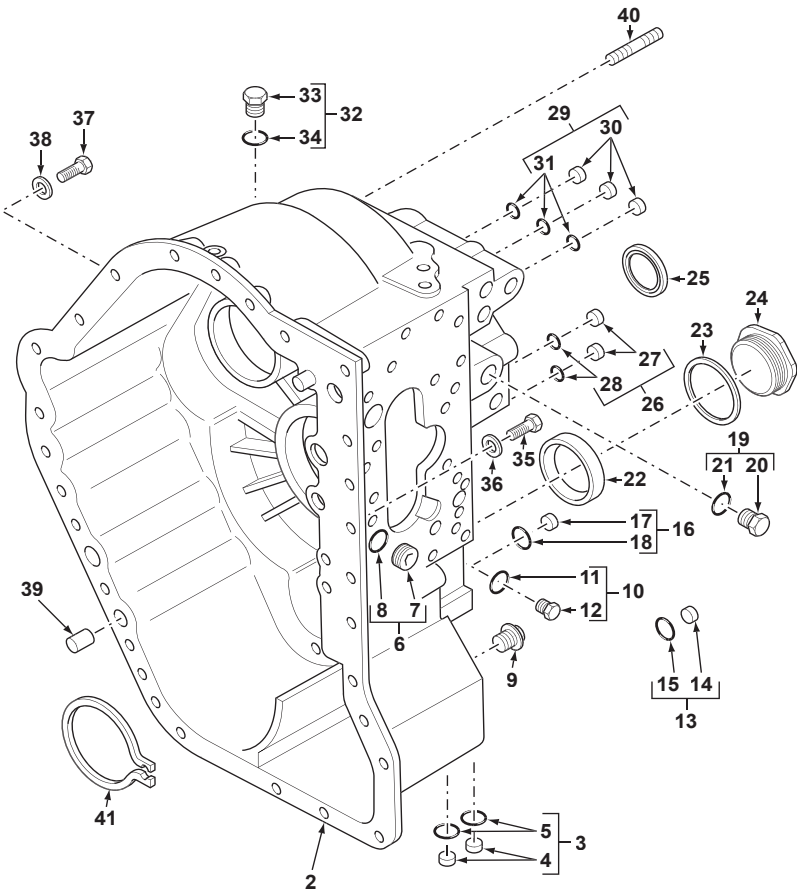

1	6109135M91		Continued 4WS	1	Gearbox	Boite de vitesses	Caja de velocidades
2	6194046M91	1		1	Housing Assy	Ensemble de carter	Cárter, Conj.
3	6193461M91	1		2	Plug	Bouchon	Tapón
4		3	➡ Ref. 3	1	Plug	Bouchon	Tapón
5	6193589M1	3		1	O-Ring	Joint torique	Junta de tipo O
6	6193461M91	1		1	Plug	Bouchon	Tapón
7		6	➡ Ref. 6	1	Plug	Bouchon	Tapón
8	6193589M1	6		1	O-Ring	Joint torique	Junta de tipo O
9	6193485M91	1		1	Plug	Bouchon	Tapón
10	6193461M91	1		1	Plug	Bouchon	Tapón
11		10	➡ Ref. 10	1	Plug	Bouchon	Tapón
12	6193589M1	10		1	O-Ring	Joint torique	Junta de tipo O
13	6193461M91	1		1	Plug	Bouchon	Tapón
14		13	➡ Ref. 13	1	Plug	Bouchon	Tapón
15	6193589M1	13		1	O-Ring	Joint torique	Junta de tipo O
16	6193461M91	1		1	Plug	Bouchon	Tapón
17		16	➡ Ref. 16	1	Plug	Bouchon	Tapón
18	6193589M1	16		1	O-Ring	Joint torique	Junta de tipo O
19	6194048M91	1		1	Plug Assy	Ensemble bouchons	Tapón, Conj.
20		19	➡ Ref. 19	1	Plug	Bouchon	Tapón
21	6194047M1	19		1	O-Ring	Joint torique	Junta de tipo O
22	6194052M1	1		1	Plug	Bouchon	Tapón
23	6194050M1	1		1	Seal	Joint	Junta
24	6194051M1	1		1	Plug	Bouchon	Tapón
25	6193479M1	1		1	Seal	Joint	Junta
26	6193461M91	1		2	Plug	Bouchon	Tapón
27		26	➡ Ref. 26	1	Plug	Bouchon	Tapón
28	6193589M1	26		1	O-Ring	Joint torique	Junta de tipo O
29	6193461M91	1		3	Plug	Bouchon	Tapón
30		29	➡ Ref. 29	1	Plug	Bouchon	Tapón
31	6193589M1	29		1	O-Ring	Joint torique	Junta de tipo O
32	6193462M91	1		1	Plug	Bouchon	Tapón
33		32	➡ Ref. 32	1	Plug	Bouchon	Tapón
34	6193590M1	32		1	O-Ring	Joint torique	Junta de tipo O
35	6194053M1	1		2	Bolt	Boulon	Perno
36	6193466M1	1		2	Washer, Lock	Rondelle de blocage	Arandela de freno
37	6193487M1	1		7	Bolt	Boulon	Perno
38	6193466M1	1		7	Washer, Lock	Rondelle de blocage	Arandela de freno
39	6193484M1	1		2	Pin	Axe	Pasador
40	6194054M1	1		4	Stud	Goujon	Espárrago
41	6194049M1	1		1	Ring, Snap	Anneau d'arrêt	Anillo de resorte



970 980
TX970B

921 922 923 931 932

29004C04.1

6199042M3

1

Jan-06

Transmission
Transmission
Transmisión

Housing
Carter
Alojamiento

4 Wheel Drive
4 Roues Motrices
4 ruedas motrices

Carraro
Carraro
Carraro

C-29005-06.1-A

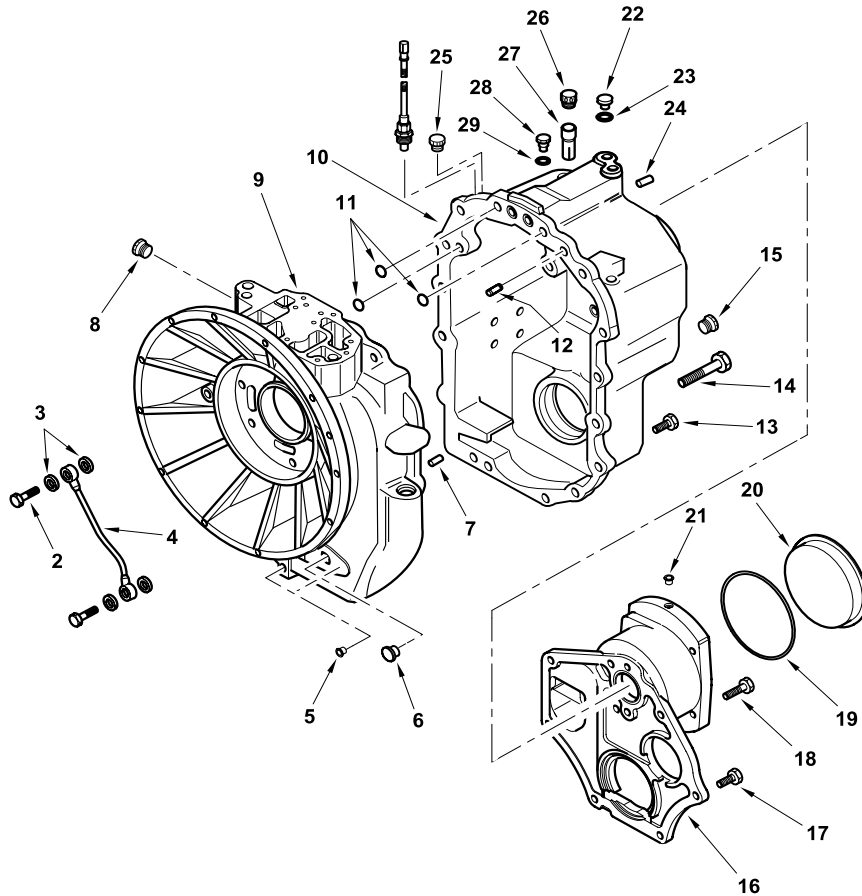

1	6110549M91		Continued	1	Gearbox	Boite de vitesses	Caja de velocidades
2	6194338M1	1	M14 x 1,5	2	Bolt	Boulon	Perno
3	6194339M1	1		2	Washer, Copper	Rondelle, cuivre	Arandela, cobre
4	6194340M1	1	Lubrication	1	Pipe	Tuyau	Tubo
5	6194337M1	1		2	Plug	Bouchon	Tapón
6	6194341M1	1	31 dia	1	Plug	Bouchon	Tapón
7	6194330M1	1	10 x 25	1	Pin	Axe	Pasador
8	6194321M1	1	7/8	1	Plug	Bouchon	Tapón
9	6194323M1	1	Front	1	Housing	Carter	Cárter
10	6194324M1	1	Rear	1	Housing	Carter	Cárter
11	6194325M1	1		3	O-Ring	Joint torique	Junta de tipo O
12	6194330M1	1	10 x 25	1	Pin	Axe	Pasador
13	6194334M1	1	M10 x 30	13	Bolt	Boulon	Perno
14	6194336M1	1	M10 x 150	2	Bolt	Boulon	Perno
15	3523632M1	1	M30 x 2	1	Plug	Bouchon	Tapón
16	6194335M1	1		1	Cover, Rear	Couvercle arrière	Tapa trasera
17	6194334M1	1	M10 x 30	6	Bolt	Boulon	Perno
18	6194333M1	1	M10 x 45	2	Bolt	Boulon	Perno
19	6194332M1	1		1	O-Ring	Joint torique	Junta de tipo O
20	6194331M1	1	127,5 dia	1	Plug	Bouchon	Tapón
21	6194337M1	1		2	Plug	Bouchon	Tapón
22	6194328M1	1		2	Plug	Bouchon	Tapón
23	6194329M1	1	10 x 14 x 1,5	2	Washer, Copper	Rondelle, cuivre	Arandela, cobre
24	6194330M1	1	10 x 25	1	Pin	Axe	Pasador
25	6194321M1	1	7/8	1	Plug	Bouchon	Tapón
26	6194326M1	1		1	Breather	Reniflard	Ventilador del cárter
27	6194327M1	1	Breather	1	Pipe	Tuyau	Tubo
28	6194328M1	1		1	Plug	Bouchon	Tapón
29	6194329M1	1	10 x 14 x 1,5	1	Washer, Copper	Rondelle, cuivre	Arandela, cobre



820 860 880
TX760B TX860B
TX870B

803 804 807 808 813 814 815 816 817 841 842 843 844 845

29005C06.1

6199042M3

1

Jan-06

Transmission
Transmission
Transmisión

Input Shaft
Arbre d'entrée
Árbol de entrada

2 Wheel Drive
2 Roues Motrices
2 ruedas motrices

C-29001-04.1-A

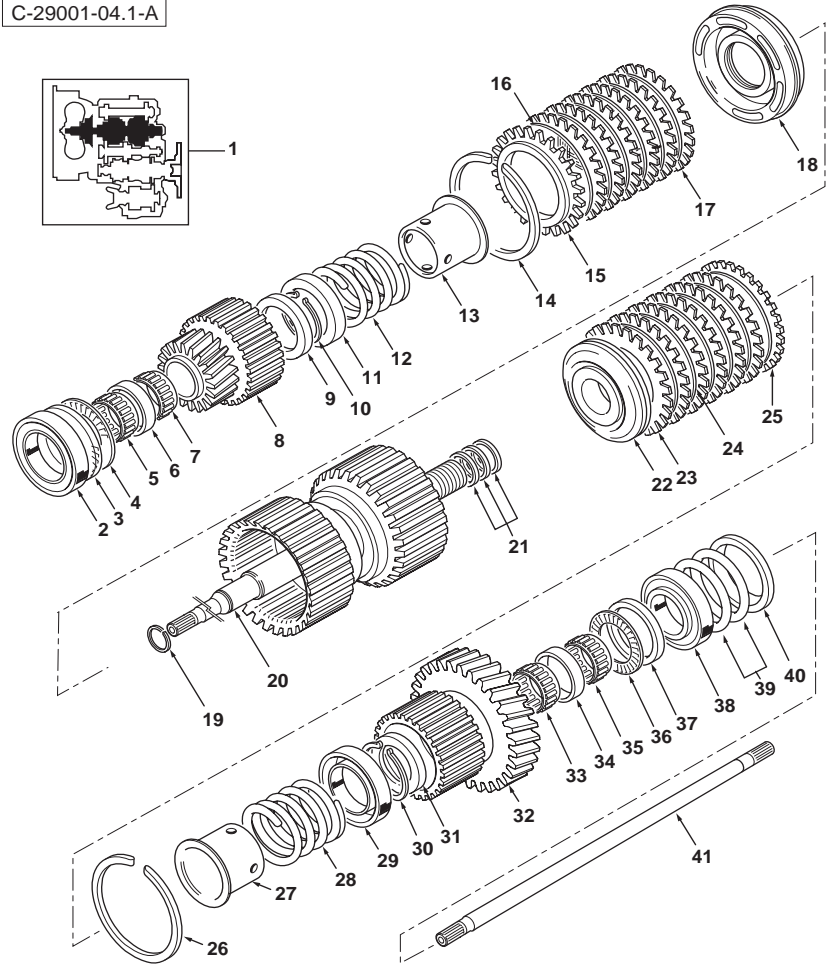

1	6109134M91		Continued 2WS	1	Gearbox	Boite de vitesses	Caja de velocidades
2	6190093M91	1		1	Bearing Assy	Roulement	Rodamiento, Conj.
3	6190031M1	1		1	Washer, Thrust	Rondelle de butée	Arandela de tope
4	6190029M1	1		1	Bearing, Thrust	Roulement butée	Cojinete axial
5	6194131M1	1		1	Bearing, Needle	Aiguilles de roulement	Cojinete, Agujas
6	6194130M1	1		1	Spacer	Entretoise	Traviesa
7	6194131M1	1		1	Bearing, Needle	Aiguilles de roulement	Cojinete, Agujas
8	6194123M1	1		1	Gear	Pignon	Piñón
9	6194121M1	1		1	Washer, Thrust	Rondelle de butée	Arandela de tope
10	6194125M1	1		1	Circlip	Segment d'arrêt	Circlip
11	6194126M1	1		1	Retainer	Dispositif de retenue	Fijación
12	6194127M1	1		1	Spring	Ressort	Muelle
13	6194128M1	1		1	Sleeve	Chemise	Camisa
14	6190103M1	1		1	Ring, Snap	Anneau d'arrêt	Anillo de resorte
15	6190104M1	1		1	Plate, Backing	Plaque d'appui	Placa de apoyo
16	6190106M1	1		6	Disc, Friction	Disque de friction	Disco de fricción
17	6190105M1	1		6	Plate, Intermediate	Plaque intermédiaire	Placa intermediaia
18	6194129M1	1		1	Piston	Piston	Pistón
19	6194136M1	1		1	Ring, Sealing	Bague d'étanchéité	Anillo, Estanqueidad
20	6194122M91	1		1	Shaft Assy	Ensemble de l'arbre	Árbol, Conj.
21	6194119M1	1		3	Ring, Sealing	Bague d'étanchéité	Anillo, Estanqueidad
22	6194129M1	1		1	Piston	Piston	Pistón
23	6190105M1	1		1	Plate, Intermediate	Plaque intermédiaire	Placa intermediaia
24	6190106M1	1		1	Disc, Friction	Disque de friction	Disco de fricción
25	6190104M1	1		1	Plate, Backing	Plaque d'appui	Placa de apoyo
26	6190103M1	1		1	Ring, Snap	Anneau d'arrêt	Anillo de resorte
27	6194128M1	1		1	Sleeve	Chemise	Camisa
28	6194127M1	1		1	Spring	Ressort	Muelle
29	6194126M1	1		1	Retainer	Dispositif de retenue	Fijación
30	6194125M1	1		1	Circlip	Segment d'arrêt	Circlip
31	6194121M1	1		1	Washer, Thrust	Rondelle de butée	Arandela de tope
32	6194124M1	1		1	Gear	Pignon	Piñón
33	6194131M1	1		1	Bearing, Needle	Aiguilles de roulement	Cojinete, Agujas
34	6194130M1	1		1	Spacer	Entretoise	Traviesa
35	6194131M1	1		1	Bearing, Needle	Aiguilles de roulement	Cojinete, Agujas
36	6190029M1	1		1	Bearing, Thrust	Roulement butée	Cojinete axial
37	6194121M1	1		1	Washer, Thrust	Rondelle de butée	Arandela de tope
38	6194132M91	1		1	Bearing Assy	Roulement	Rodamiento, Conj.
39	6194141M1	1	0.051"	X	Shim	Cale	Calce
39	6194142M1	1	0.076"	X	Shim	Cale	Calce
39	6194143M1	1	0.178"	X	Shim	Cale	Calce
39	6194144M1	1	0.599"	X	Shim	Cale	Calce
40	6194140M1	1		1	Spacer	Entretoise	Traviesa
41	6194145M1	1		1	Shaft	Arbre	Árbol



820
TX760B TX860B
TX870B

801 802 805 806 809 810 811 812

29001C04.1

6199042M3

1

Jan-06

Transmission
Transmission
Transmisión

Input Shaft
Arbre d'entrée
Árbol de entrada

2 Wheel Drive
2 Roues Motrices
2 ruedas motrices

C-29001-04.1-A

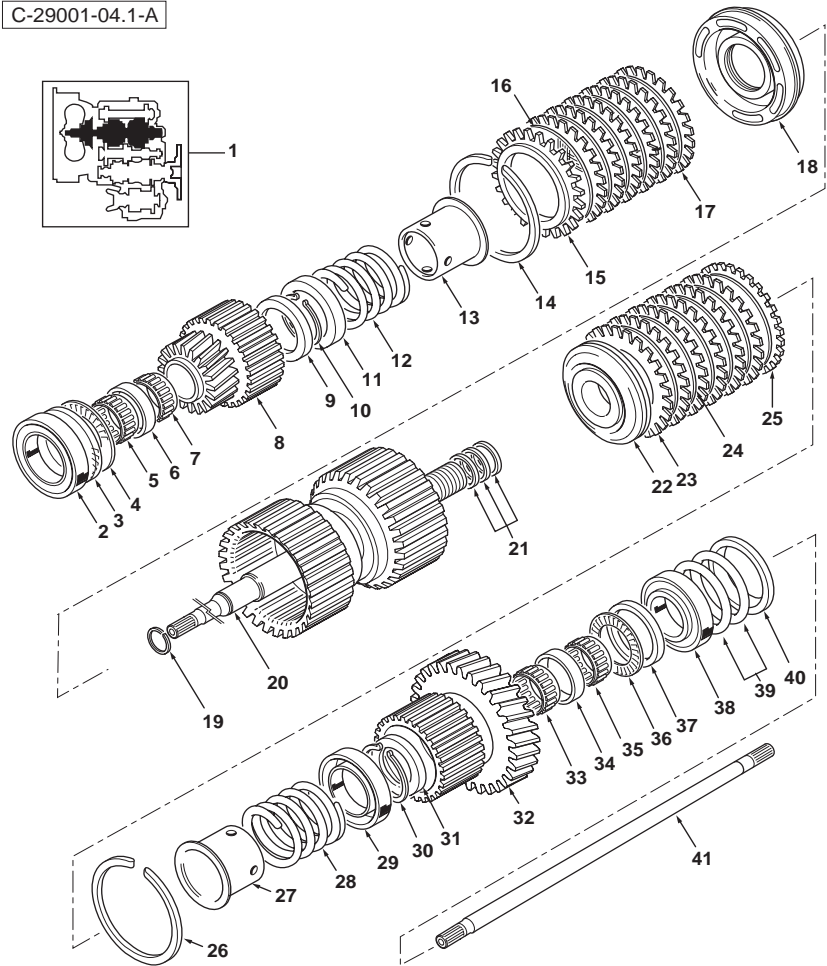

820
TX760B TX860B
TX870B

801 802 805 806 809 810 811 812

29001C04.1

6199042M3

1

Jan-06

Transmission
Transmission
Transmisión

Input Shaft
Arbre d'entrée
Árbol de entrada

4 Wheel Drive
4 Roues Motrices
4 ruedas motrices

C-29002-04.1-A

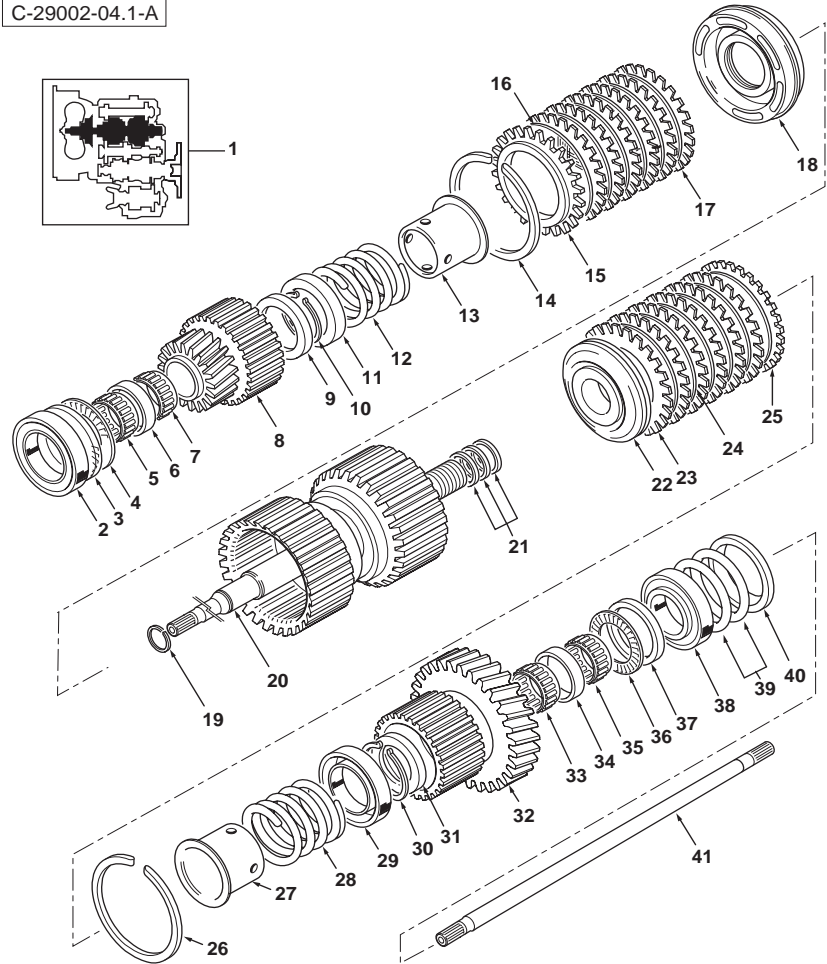

1	6108873M91		Continued 2WS	1	Gearbox	Boite de vitesses	Caja de velocidades
2	6190093M91	1		1	Bearing Assy	Roulement	Rodamiento, Conj.
3	6190031M1	1		1	Washer, Thrust	Rondelle de butée	Arandela de tope
4	6190029M1	1		1	Bearing, Thrust	Roulement butée	Cojinete axial
5	6194131M1	1		1	Bearing, Needle	Aiguilles de roulement	Cojinete, Agujas
6	6194130M1	1		1	Spacer	Entretoise	Traviesa
7	6194131M1	1		1	Bearing, Needle	Aiguilles de roulement	Cojinete, Agujas
8	6194123M1	1		1	Gear	Pignon	Piñón
9	6194121M1	1		1	Washer, Thrust	Rondelle de butée	Arandela de tope
10	6194125M1	1		1	Circlip	Segment d'arrêt	Circlip
11	6194126M1	1		1	Retainer	Dispositif de retenue	Fijación
12	6194127M1	1		1	Spring	Ressort	Muelle
13	6194128M1	1		1	Sleeve	Chemise	Camisa
14	6190103M1	1		1	Ring, Snap	Anneau d'arrêt	Anillo de resorte
15	6190104M1	1		1	Plate, Backing	Plaque d'appui	Placa de apoyo
16	6190106M1	1		6	Disc, Friction	Disque de friction	Disco de fricción
17	6190105M1	1		6	Plate, Intermediate	Plaque intermédiaire	Placa intermediaaria
18	6194129M1	1		1	Piston	Piston	Pistón
19	6194136M1	1		1	Ring, Sealing	Bague d'étanchéité	Anillo, Estanqueidad
20	6194122M91	1		1	Shaft Assy	Ensemble de l'arbre	Árbol, Conj.
21	6194119M1	1		3	Ring, Sealing	Bague d'étanchéité	Anillo, Estanqueidad
22	6194129M1	1		1	Piston	Piston	Pistón
23	6190105M1	1		1	Plate, Intermediate	Plaque intermédiaire	Placa intermediaaria
24	6190106M1	1		1	Disc, Friction	Disque de friction	Disco de fricción
25	6190104M1	1		1	Plate, Backing	Plaque d'appui	Placa de apoyo
26	6190103M1	1		1	Ring, Snap	Anneau d'arrêt	Anillo de resorte
27	6194128M1	1		1	Sleeve	Chemise	Camisa
28	6194127M1	1		1	Spring	Ressort	Muelle
29	6194126M1	1		1	Retainer	Dispositif de retenue	Fijación
30	6194125M1	1		1	Circlip	Segment d'arrêt	Circlip
31	6194121M1	1		1	Washer, Thrust	Rondelle de butée	Arandela de tope
32	6194124M1	1		1	Gear	Pignon	Piñón
33	6194131M1	1		1	Bearing, Needle	Aiguilles de roulement	Cojinete, Agujas
34	6194130M1	1		1	Spacer	Entretoise	Traviesa
35	6194131M1	1		1	Bearing, Needle	Aiguilles de roulement	Cojinete, Agujas
36	6190029M1	1		1	Bearing, Thrust	Roulement butée	Cojinete axial
37	6194121M1	1		1	Washer, Thrust	Rondelle de butée	Arandela de tope
38	6194132M91	1		1	Bearing Assy	Roulement	Rodamiento, Conj.
39	6194141M1	1	0.051"	X	Shim	Cale	Calce
39	6194142M1	1	0.076"	X	Shim	Cale	Calce
39	6194143M1	1	0.178"	X	Shim	Cale	Calce
39	6194144M1	1	0.599"	X	Shim	Cale	Calce
40	6194140M1	1		1	Spacer	Entretoise	Traviesa
41	6194145M1	1		1	Shaft	Arbre	Árbol



820 860 880
TX760B TX860B
TX870B

803 804 807 808 813 814 815 816 817 831 832 833 834 841 842 843 844 845

29002C04.1

6199042M3

1

Jan-06

Transmission
Transmission
Transmisión

Input Shaft
Arbre d'entrée
Árbol de entrada

4 Wheel Drive
4 Roues Motrices
4 ruedas motrices

C-29002-04.1-A

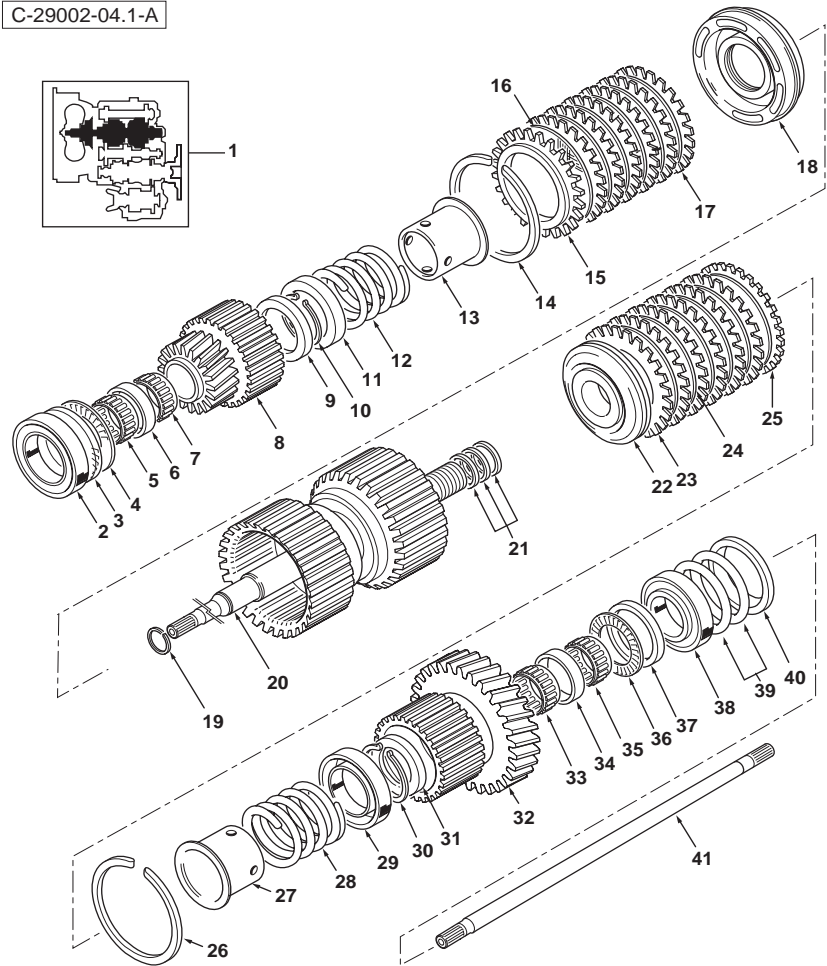

820 860 880
TX760B TX860B
TX870B

803 804 807 808 813 814 815 816 817 831 832 833 834 841 842 843 844 845

29002C04.1

6199042M3

1

Jan-06

Transmission
Transmission
Transmisión

Input Shaft
Arbre d'entrée
Árbol de entrada

Powershift
Powershift
Powershift

C-29003-09.1-A

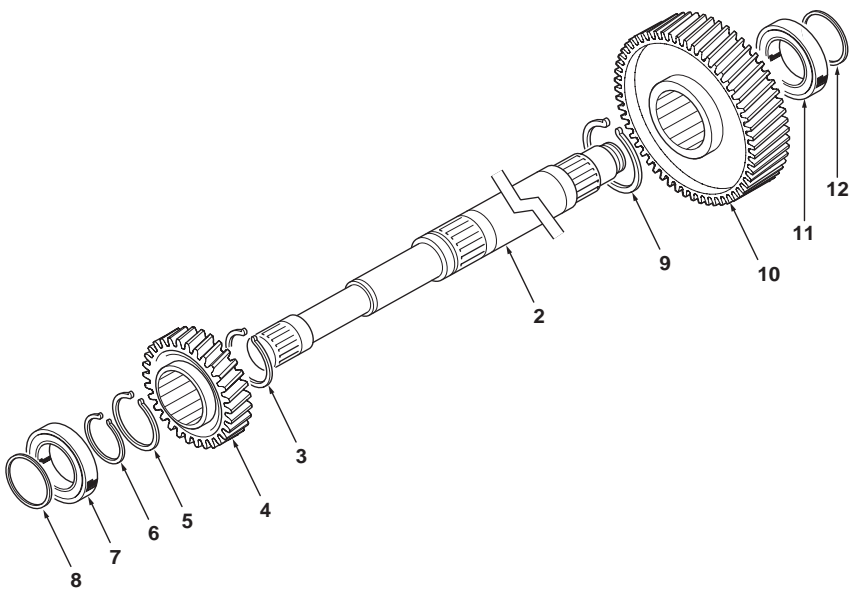

1	6108875M91		Continued 2WS	1	Gearbox	Boite de vitesses	Caja de velocidades
2	6193536M1	1		1	Shaft Assy	Ensemble de l'arbre	Árbol, Conj.
3	6193537M1	1		1	Ring, Snap	Anneau d'arrêt	Anillo de resorte
4	6193538M1	1	26T	1	Gear	Pignon	Piñón
5	6193513M1	1		1	Ring, Snap	Anneau d'arrêt	Anillo de resorte
6	6193539M1	1		1	Ring, Snap	Anneau d'arrêt	Anillo de resorte
7	6193535M91	1		1	Bearing	Coussinet	Cojinete
8	6193525M1	1		1	Ring	Anneau	Aro
9	6193513M1	1		1	Ring, Snap	Anneau d'arrêt	Anillo de resorte
10	6193541M1	1	62T	1	Gear	Pignon	Piñón
11	6193535M91	1		1	Bearing	Coussinet	Cojinete
12	6193525M1	1		1	Ring	Anneau	Aro



860 880
TX860B TX870B

821 822 823 824 825 851 852 853 854 855

29003C09.1

6199042M3

1

Jan-06

Transmission
Transmission
Transmisión

Input Shaft
Arbre d'entrée
Árbol de entrada

Powershift
Powershift
Powershift

C-29004-09.1-A

1	6109135M91		Continued 4WS	1	Gearbox	Boite de vitesses	Caja de velocidades																																																
2	6193536M1	1		1	Shaft Assy	Ensemble de l'arbre	Árbol, Conj.																																																
3	6193537M1	1		1	Ring, Snap	Anneau d'arrêt	Anillo de resorte																																																
4	6193538M1	1	26T	1	Gear	Pignon	Piñón																																																
5	6193513M1	1		1	Ring, Snap	Anneau d'arrêt	Anillo de resorte																																																
6	6193539M1	1		1	Ring, Snap	Anneau d'arrêt	Anillo de resorte </tr <tr> <td>7</td> <td>6193535M91</td> <td>1</td> <td></td> <td>1</td> <td>Bearing</td> <td>Coussinet</td> <td>Cojinete</td> </tr> <tr> <td>8</td> <td>6193525M1</td> <td>1</td> <td></td> <td>1</td> <td>Ring</td> <td>Anneau</td> <td>Aro</td> </tr> <tr> <td>9</td> <td>6193513M1</td> <td>1</td> <td></td> <td>1</td> <td>Ring, Snap</td> <td>Anneau d'arrêt</td> <td>Anillo de resorte</td> </tr> <tr> <td>10</td> <td>6193541M1</td> <td>1</td> <td>62T</td> <td>1</td> <td>Gear</td> <td>Pignon</td> <td>Piñón</td> </tr> <tr> <td>11</td> <td>6193535M91</td> <td>1</td> <td></td> <td>1</td> <td>Bearing</td> <td>Coussinet</td> <td>Cojinete</td> </tr> <tr> <td>12</td> <td>6193525M1</td> <td>1</td> <td></td> <td>1</td> <td>Ring</td> <td>Anneau</td> <td>Aro</td> </tr>	7	6193535M91	1		1	Bearing	Coussinet	Cojinete	8	6193525M1	1		1	Ring	Anneau	Aro	9	6193513M1	1		1	Ring, Snap	Anneau d'arrêt	Anillo de resorte	10	6193541M1	1	62T	1	Gear	Pignon	Piñón	11	6193535M91	1		1	Bearing	Coussinet	Cojinete	12	6193525M1	1		1	Ring	Anneau	Aro
7	6193535M91	1		1	Bearing	Coussinet	Cojinete																																																
8	6193525M1	1		1	Ring	Anneau	Aro																																																
9	6193513M1	1		1	Ring, Snap	Anneau d'arrêt	Anillo de resorte																																																
10	6193541M1	1	62T	1	Gear	Pignon	Piñón																																																
11	6193535M91	1		1	Bearing	Coussinet	Cojinete																																																
12	6193525M1	1		1	Ring	Anneau	Aro																																																

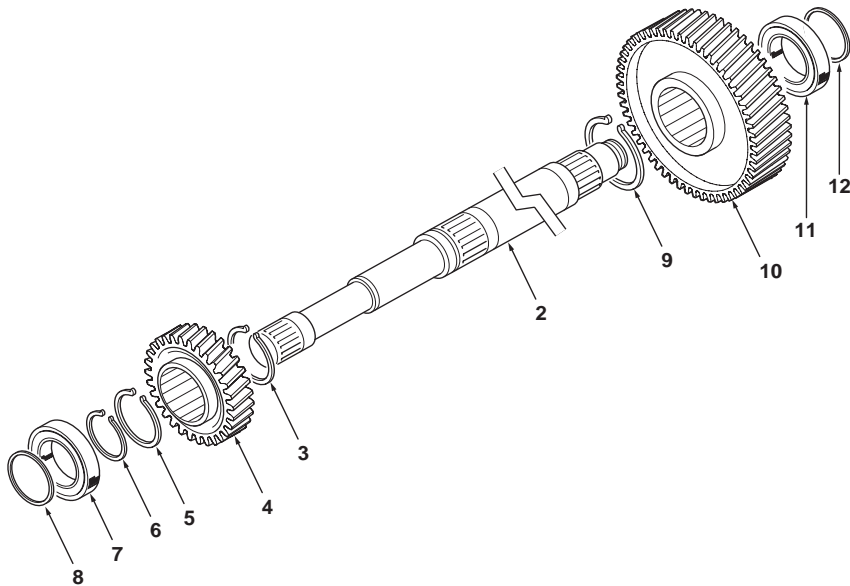

970 980
TX970B

921 922 923 931 932

29004C09.1

6199042M3

1

Jan-06

Transmission
Transmission
Transmisión

Input Shaft
Arbre d'entrée
Árbol de entrada

4 Wheel Drive
4 Roues Motrices
4 ruedas motrices

Carraro
Carraro
Carraro

C-29005-07.1-B

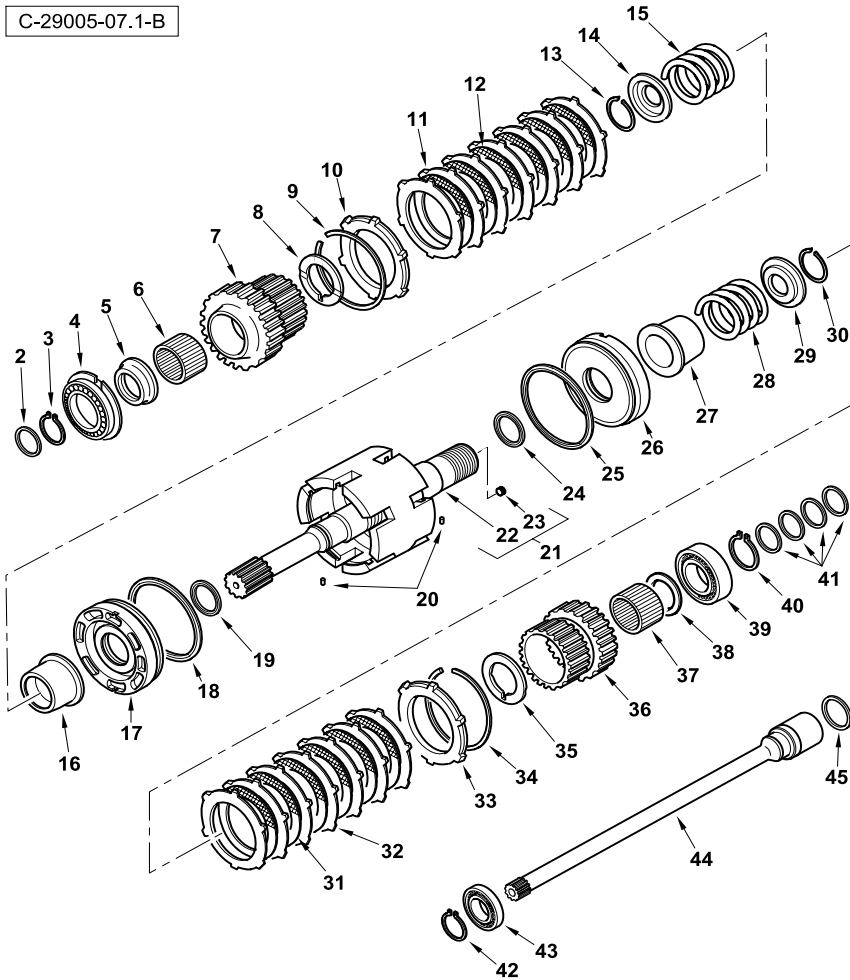

1	6110549M91		Continued	1	Gearbox	Boite de vitesses	Caja de velocidades
2	6194343M1	1	45 mm	1	Ring, Sealing	Bague d'étanchéité	Anillo, Estanqueidad
3	6190292M1	1	45 mm	1	Ring, Snap	Anneau d'arrêt	Anillo de resorte
4	6194345M1	1		1	Bearing	Coussinet	Cojinete
5	6194346M1	1	68 x 45 x 105	1	Spacer	Entretoise	Travesa
6	6194347M1	1		1	Bearing, Needle	Aiguilles de roulement	Cojinete, Agujas
7	6194348M1	1		1	Gear	Pignon	Piñón
8	6194351M1	1	60 x 50 x 4	1	Washer, Thrust	Rondelle de butée	Arandela de tope
9	6194349M1	1		1	Ring, Retaining	Anneau de retenue	Anillo de retención
10	6194350M1	1	Clutch	1	Plate, Locking	Plaque d'arrêt	Placa de bloqueo
11	6194352M1	1		7	Plate, Drive	Disque d'entraînement	Disco accionamiento
12	6194353M1	1		6	Plate, Friction	Plateau	Plato
13	6194495M1	1		1	Ring, Retaining	Anneau de retenue	Anillo de retención
14	6194355M1	1		1	Cup, Spring	Cuvette ressort	Cubeta muelle
15	6194354M1	1		1	Spring	Ressort	Muelle
16	6194357M1	1		1	Sleeve	Chemise	Camisa
17	6194358M1	1		1	Piston	Piston	Pistón
18	6194359M1	1		1	Ring, Sealing	Bague d'étanchéité	Anillo, Estanqueidad
19	6194360M1	1	55 mm	1	Ring, Sealing	Bague d'étanchéité	Anillo, Estanqueidad
20	6194365M1	1		1	Pin, Roll	Goupille élastique	Pasador elástico
21	6194496M91	1	Inner	2	Shaft Assy	Ensemble de l'arbre	Árbol, Conj.
22		21	Ref. 21	1	Shaft	Arbre	Árbol
23	6194497M1	21		4	Rivet	Rivet	Remache
24	6194360M1	1	55 mm	1	Ring, Sealing	Bague d'étanchéité	Anillo, Estanqueidad
25	6194359M1	1		1	Ring, Sealing	Bague d'étanchéité	Anillo, Estanqueidad
26	6194358M1	1		1	Piston	Piston	Pistón
27	6194357M1	1		1	Sleeve	Chemise	Camisa
28	6194354M1	1		1	Spring	Ressort	Muelle
29	6194355M1	1		1	Cup, Spring	Cuvette ressort	Cubeta muelle
30	6194495M1	1		1	Ring, Retaining	Anneau de retenue	Anillo de retención
31	6194353M1	1		6	Plate, Friction	Plateau	Plato
32	6194352M1	1		7	Plate, Drive	Disque d'entraînement	Disco accionamiento
33	6194350M1	1	Clutch	1	Plate, Locking	Plaque d'arrêt	Placa de bloqueo
34	6194349M1	1		1	Ring, Retaining	Anneau de retenue	Anillo de retención
35	6194351M1	1	60 x 50 x 4	1	Washer, Thrust	Rondelle de butée	Arandela de tope
36	6194362M1	1		1	Gear	Pignon	Piñón
37	6194347M1	1		1	Bearing, Needle	Aiguilles de roulement	Cojinete, Agujas
38	6194351M1	1	60 x 50 x 4	1	Washer, Thrust	Rondelle de butée	Arandela de tope
39	6194364M1	1		1	Bearing	Coussinet	Cojinete
40	6190292M1	1	45 mm	1	Ring, Snap	Anneau d'arrêt	Anillo de resorte
41	6194363M1	1		4	Seal	Joint	Junta
42	6194368M1	1		1	Ring, Snap	Anneau d'arrêt	Anillo de resorte
43	6194367M1	1		1	Bearing	Coussinet	Cojinete
44	6194366M1	1	PTO	1	Shaft	Arbre	Árbol



820 860 880
TX760B TX860B
TX870B

803 804 807 808 813 814 815 816 817 841 842 843 844 845

29005C07.1

6199042M3

1

Jan-06

Transmission
Transmission
Transmisión

Input Shaft
Arbre d'entrée
Árbol de entrada

4 Wheel Drive
4 Roues Motrices
4 ruedas motrices

Carraro
Carraro
Carraro

C-29005-07.1-B

45	6194343M1	1	45 mm	1	Ring, Sealing	Bague d'étanchéité	Anillo, Estanqueidad
----	-----------	---	-------	---	---------------	--------------------	----------------------

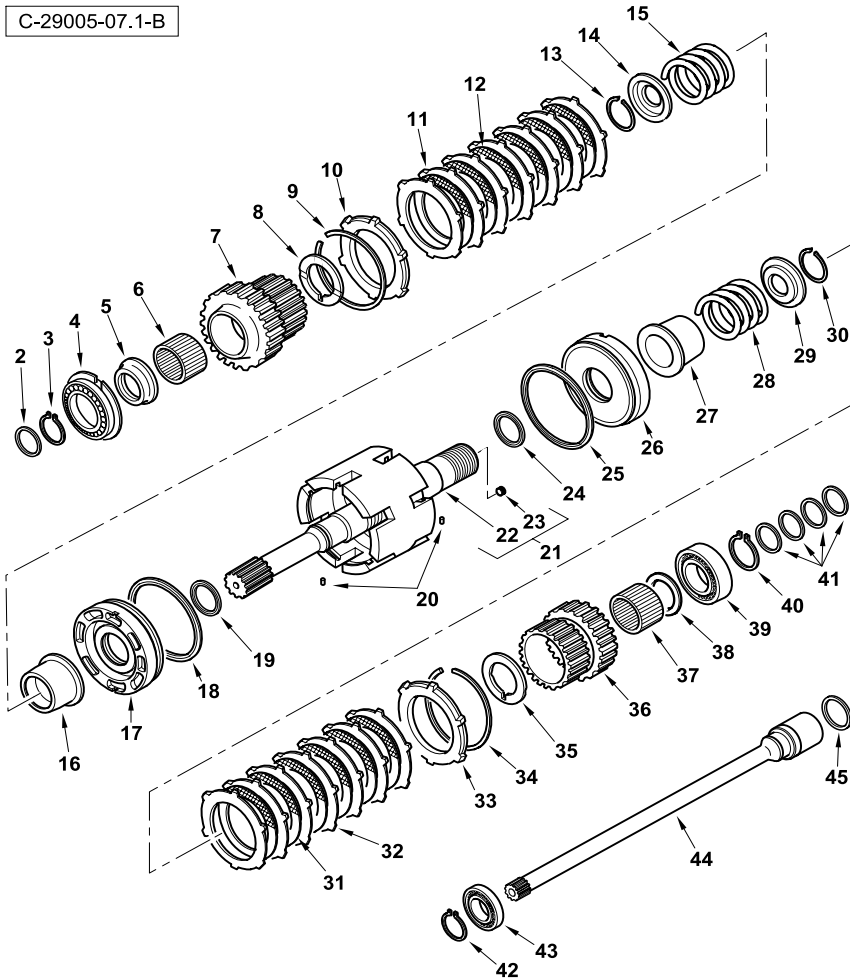

820 860 880
TX760B TX860B
TX870B

803 804 807 808 813 814 815 816 817 841 842 843 844 845

29005C07.1

6199042M3

1

Jan-06

Transmission
Transmission
Transmisión

Main Shaft
Arbre Principal
Árbol principal

2 Wheel Drive
2 Roues Motrices
2 ruedas motrices

C-29001-06.1-A

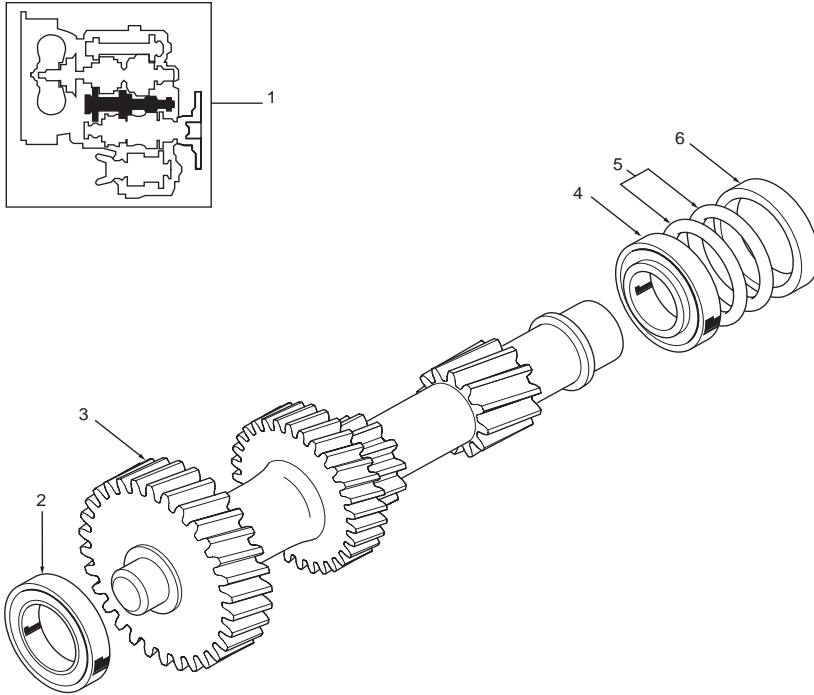

1	6109134M91		Continued 2WS	1	Gearbox	Boite de vitesses	Caja de velocidades
2	6190094M91	1		1	Bearing Assy	Roulement	Rodamiento, Conj.
3	6190097M1	1		1	Shaft, Gear	Arbre de pignon	Árbol de piñón
4	6190086M91	1		1	Bearing Assy	Roulement	Rodamiento, Conj.
5	6190088M1	1	0.002"	X	Shim	Calce	Calce
5	6190089M1	1	0.003"	X	Shim	Calce	Calce
5	6190090M1	1	0.007"	X	Shim	Calce	Calce
5	6190091M1	1	0.024"	X	Shim	Calce	Calce
6	6190087M1	1		1	Spacer	Entretoise	Travesa



820
TX760B TX860B
TX870B

801 802 805 806 809 810 811 812

29001C06.1

6199042M3

1

Jan-06

Transmission
Transmission
Transmisión

Main Shaft
Arbre Principal
Árbol principal

4 Wheel Drive
4 Roues Motrices
4 ruedas motrices

C-29002-06.1-A

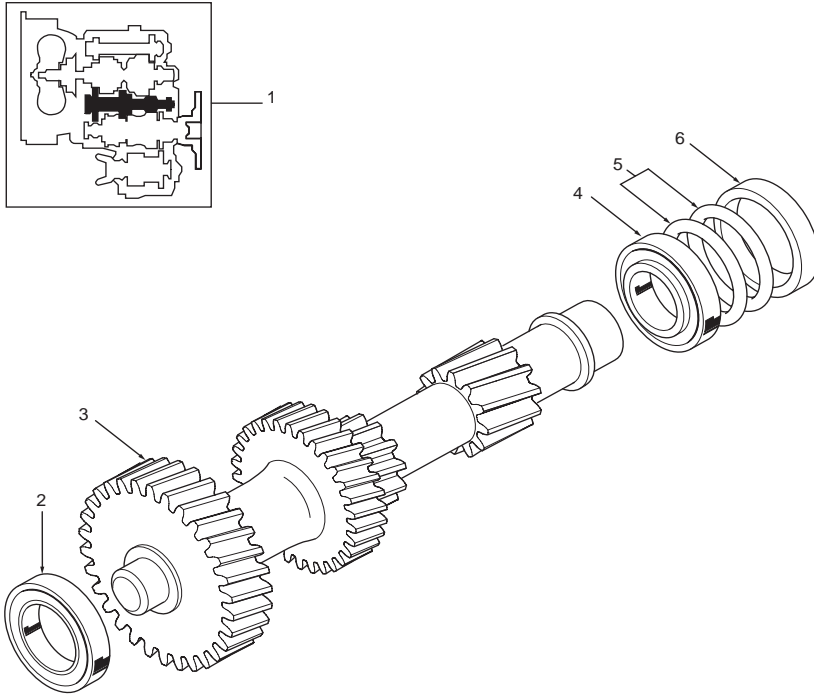

1	6108873M91		Continued 2WS	1	Gearbox	Boite de vitesses	Caja de velocidades
2	6190094M91	1		1	Bearing Assy	Roulement	Rodamiento, Conj.
3	6190097M1	1		1	Shaft, Gear	Arbre de pignon	Árbol de piñón
4	6190086M91	1		1	Bearing Assy	Roulement	Rodamiento, Conj.
5	6190088M1	1	0.002"	X	Shim	Calce	Calce
5	6190089M1	1	0.003"	X	Shim	Calce	Calce
5	6190090M1	1	0.007"	X	Shim	Calce	Calce
5	6190091M1	1	0.024"	X	Shim	Calce	Calce
6	6190087M1	1		1	Spacer	Entretoise	Travesa



820 860 880
TX760B TX860B
TX870B

803 804 807 808 813 814 815 816 817 831 832 833 834 841 842 843 844 845

29002C06.1

6199042M3

1

Jan-06

Transmission
Transmission
Transmisión

Oil Filler
Bouchon de Remplissage d'huile
Tubo de llenado aceite

2 Wheel Drive
2 Roues Motrices
2 ruedas motrices

C-29001-01.1-A

1	6109104M91		1	Tube Assy	Tuyauterie	Conjunto de tubería
2	6110288M1		1	Angle	Cornière	Esquilla
3	3516392M1		1	Clip	Clip	Clip
4	339020X1	M12 x 20	1	Screw	Vis	Tornillo
5	339761X1	M8 x 25	1	Screw	Vis	Tornillo
6	385361X1	M8	1	Washer	Rondelle	Arandela
7	394367X1	M8	1	Nut, Lock	Écrou de blocage	Tuerca de retención
8	6110856M91		1	Dipstick	Jauge à huile	Calibre de aceite
9	6108638M91	1-5/16 UNF	1	Elbow	Coude	Codo
10		9  Ref. 9	1	Elbow	Coude	Codo
11	835026M1	9	1	O-Ring	Joint torique	Junta de tipo O

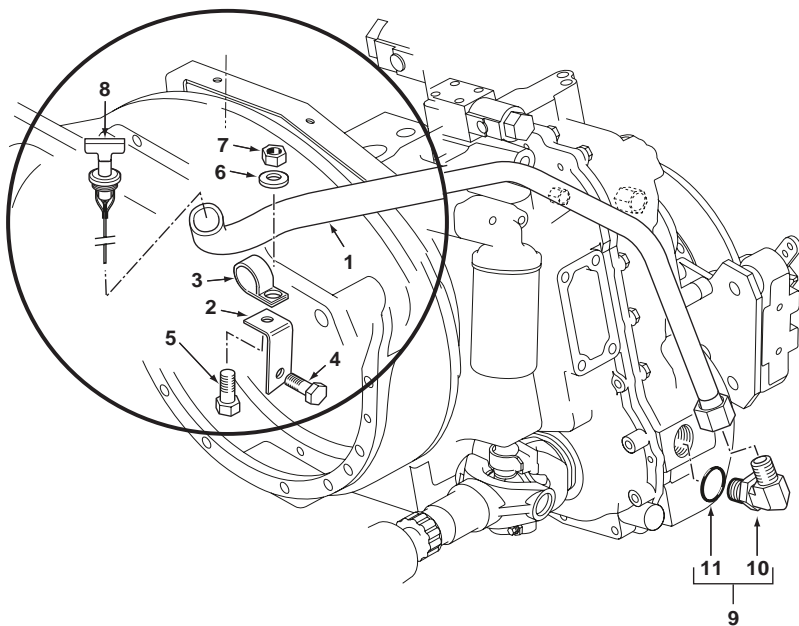

820
TX760B TX860B
TX870B

801 802 805 806 809 810 811 812

29001C01.1

6199042M3

1

Jan-06

Transmission
Transmission
Transmisión

Oil Filler
Bouchon de Remplissage d'huile
Tubo de llenado aceite

2 Wheel Steer
2 Roues Directrices
Dirección en 2 ruedas

C-29002-01.1-A

1	6109104M91		1	Tube Assy	Tuyauterie	Conjunto de tubería
2	6110288M1		1	Angle	Cornière	Esquilla
3	3516392M1		1	Clip	Clip	Clip
4	339020X1	M12 x 20	1	Screw	Vis	Tornillo
5	339761X1	M8 x 25	1	Screw	Vis	Tornillo
6	385361X1	M8	1	Washer	Rondelle	Arandela
7	394367X1	M8	1	Nut, Lock	Écrou de blocage	Tuerca de retención
8	6110856M91		1	Dipstick	Jauge à huile	Calibre de aceite
9	6108638M91	1-5/16 UNF	1	Elbow	Coude	Codo
10		9	1	Elbow	Coude	Codo
11	835026M1	9	1	O-Ring	Joint torique	Junta de tipo O

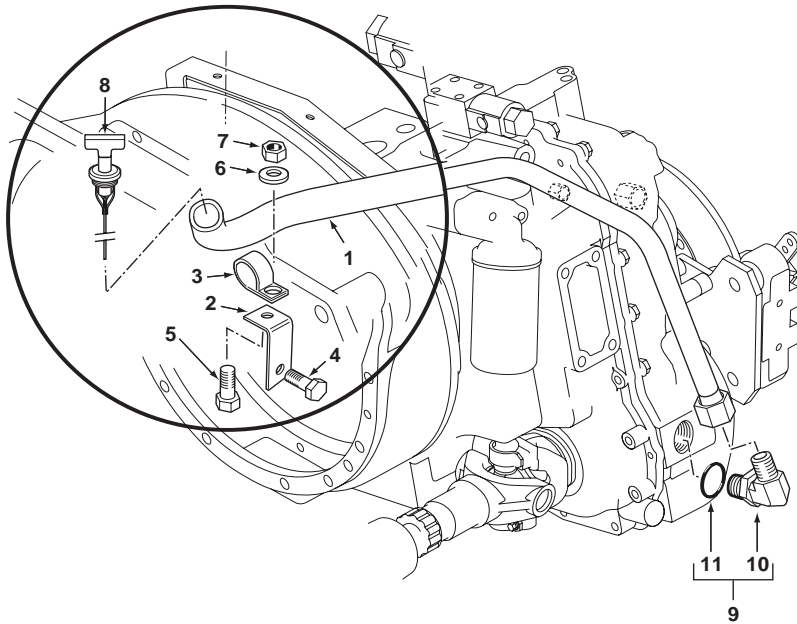

820 860 880
TX760B TX860B
TX870B

803 804 807 808 813 814 815 816 817 831 832 833 834 841 842 843 844 845

29002C01.1

6199042M3

1

Jan-06

Transmission
Transmission
Transmisión

Oil Filler
Bouchon de Remplissage d'huile
Tubo de llenado aceite

2 Wheel Steer
2 Roues Directrices
Dirección en 2 ruedas

C-29003-01.1-A

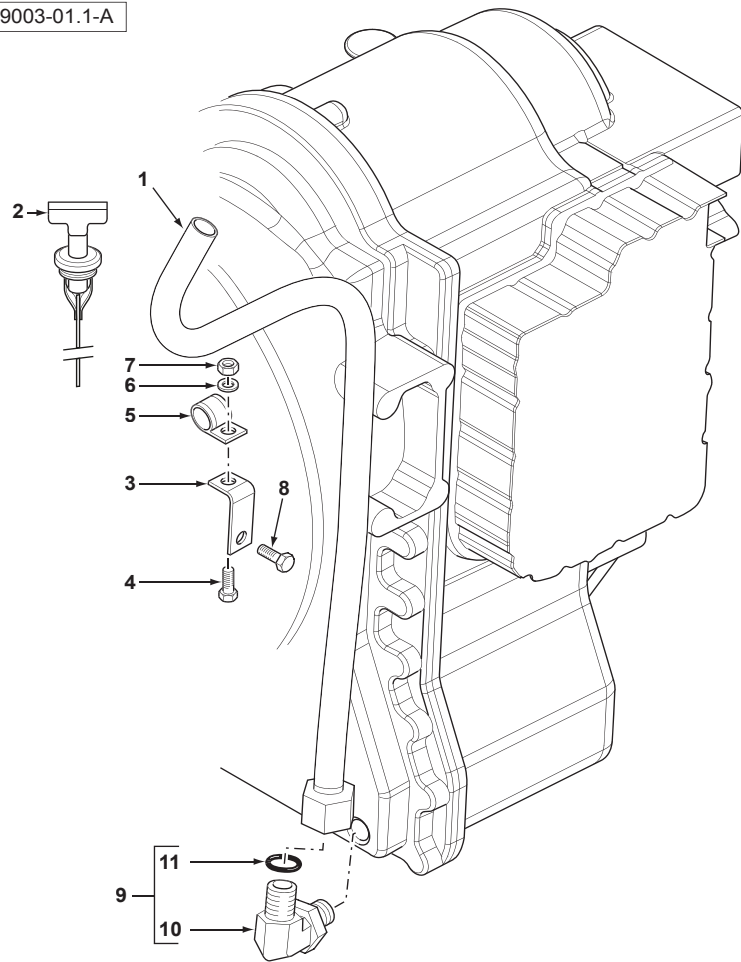

1	6109106M92		1	Tube Assy	Tuyauterie	Conjunto de tubería
2	6109191M92		1	Dipstick	Jauge à huile	Calibre de aceite
3	6110288M1		1	Angle	Cornière	Esquilla
4	339761X1	M8 x 25	1	Screw	Vis	Tornillo
5	3516392M1		1	Clip	Clip	Clip
6	385361X1	M8	1	Washer	Rondelle	Arandela
7	394367X1	M8	1	Nut, Lock	Écrou de blocage	Tuerca de retención
8	339020X1	M12 x 20	1	Screw	Vis	Tornillo
9	6108638M91	1-5/16 UNF	1	Elbow	Coude	Codo
10		9	1	Elbow	Coude	Codo
11	835026M1	9	1	O-Ring	Joint torique	Junta de tipo O



860 880
TX860B TX870B

821 822 823 824 825 851 852 853 854 855

29003C01.1

6199042M3

1

Jan-06

Transmission
Transmission
Transmisión

Oil Filler
Bouchon de Remplissage d'huile
Tubo de llenado aceite

4 Wheel Steer
4 Roues Directrices
Dirección en las 4 ruedas

C-29004-01.1-A

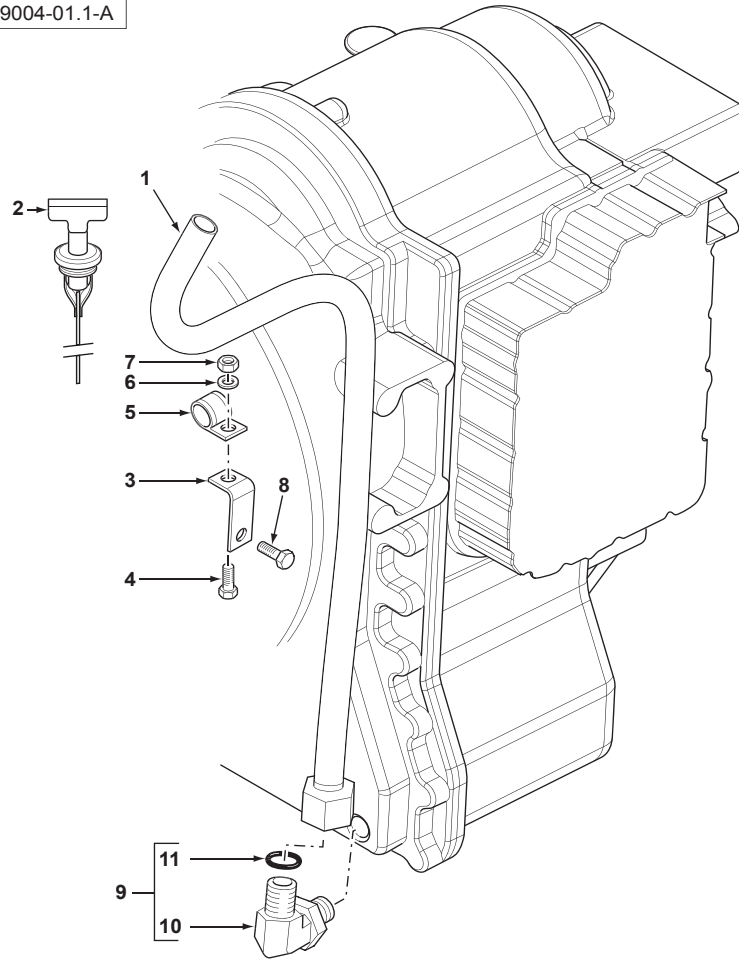

1	6109106M92		1	Tube Assy	Tuyauterie	Conjunto de tubería
2	6109191M92		1	Dipstick	Jauge à huile	Calibre de aceite
3	6110288M1		1	Angle	Cornière	Esquilla
4	339761X1	M8 x 25	1	Screw	Vis	Tornillo
5	3516392M1		1	Clip	Clip	Clip
6	385361X1	M8	1	Washer	Rondelle	Arandela
7	394367X1	M8	1	Nut, Lock	Écrou de blocage	Tuerca de retención
8	339020X1	M12 x 20	1	Screw	Vis	Tornillo
9	6108638M91	1-5/16 UNF	1	Elbow	Coude	Codo
10		9	1	Elbow	Coude	Codo
11	835026M1	9	1	O-Ring	Joint torique	Junta de tipo O



970 980
TX970B

921 922 923 931 932

29004C01.1

6199042M3

1

Jan-06

Transmission
Transmission
Transmisión

Oil Filler
Bouchon de Remplissage d'huile
Tubo de llenado aceite

4 Wheel Drive
4 Roues Motrices
4 ruedas motrices

Carraro
Carraro
Carraro

C-29005-02.1-A

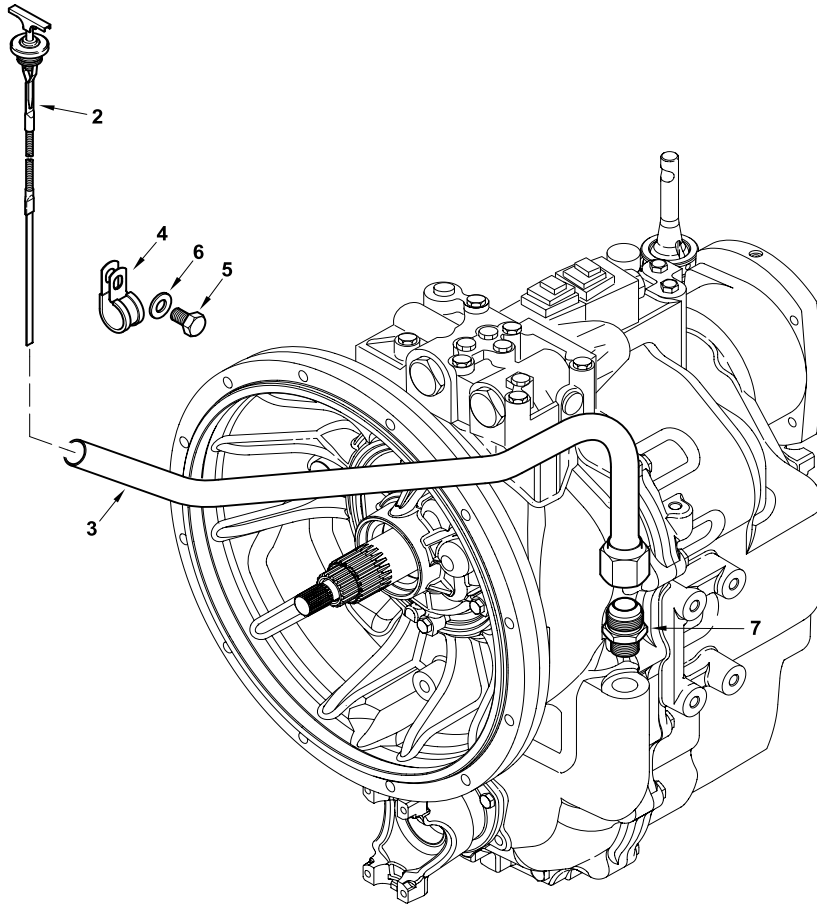

1	6110549M91		Continued	1	Gearbox	Boite de vitesses	Caja de velocidades
2	6110860M91	1		1	Dipstick	Jauge à huile	Calibre de aceite
3	6110561M91	1		1	Tube Assy	Tuyauterie	Conjunto de tubería
4	6110569M1	1		1	Clip, Mounting	Collier de fixation	Argolla de fijación
5	339020X1	1	M12 x 20	1	Screw	Vis	Tornillo
6	390735X1	1	M12	1	Washer	Rondelle	Arandela
7	6110568M1	1		1	Connector	Connecteur	Conector



820 860 880
TX760B TX860B
TX870B

803 804 807 808 813 814 815 816 817 841 842 843 844 845

29005C02.1

6199042M3

1

Jan-06

Transmission
Transmission
Transmisión

Oil Filter
Filtre à Huile
Filtro de aceite

4 Wheel Drive
4 Roues Motrices
4 ruedas motrices

Carraro
Carraro
Carraro

C-29005-03.1-A

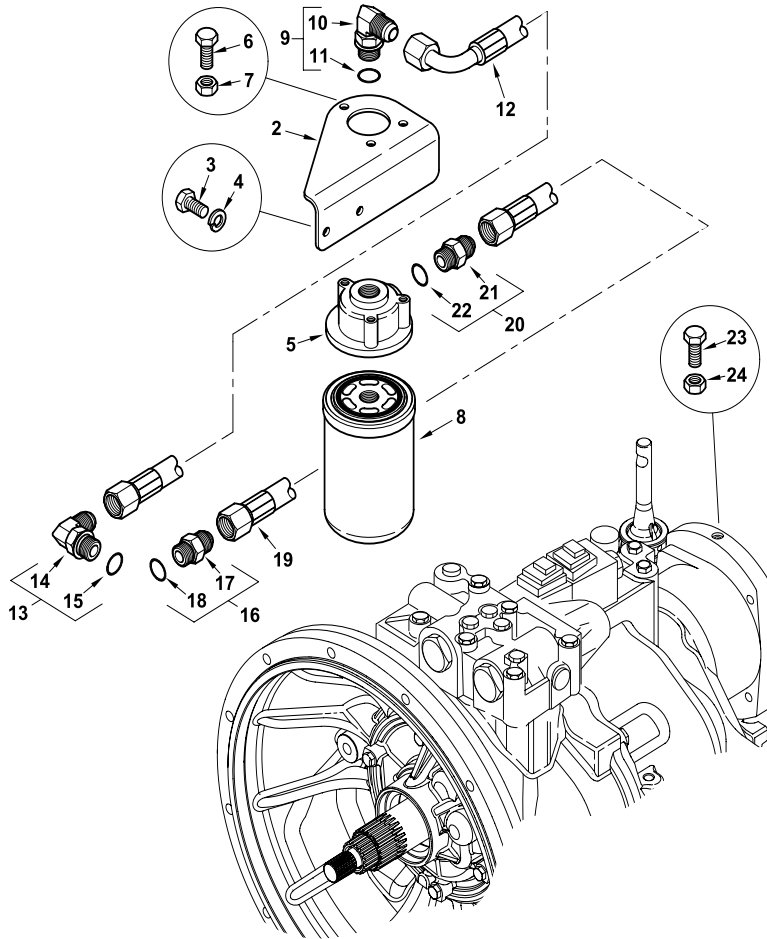

1	6110549M91		Continued	1	Gearbox	Boite de vitesses	Caja de velocidades
2	6110580M1	1		1	Bracket	Patte de fixation	Pata de fijación
3	339124X1	1	M8 x 16	2	Screw	Vis	Tornillo
4	339374X1	1	M8	2	Washer, Lock	Rondelle de blocage	Arandela de freno
5	6110605M91	1		1	Head, Filter	Tête de filtre	Cabeza de filtro
6	339124X1	1	M8 x 16	3	Screw	Vis	Tornillo
7	339374X1	1	M8	3	Washer, Lock	Rondelle de blocage	Arandela de freno
8	6110604M91	1		1	Filter, Oil	Filtre à huile	Filtro de aceite
9	835007M91	1		1	Elbow, 90°	Coude à 90°	Codo, 90°
10		9	➡ Ref. 9	1	Elbow	Coude	Codo
11	835024M1	9		1	O-Ring	Joint torique	Junta de tipo O
12	6110581M91	1	Filter Flow	1	Hose Assy	Ensemble de flexible	Flexible, Conj.
13	835007M91	1		1	Elbow, 90°	Coude à 90°	Codo, 90°
14		13	➡ Ref. 13	1	Elbow	Coude	Codo
15	835024M1	13		1	O-Ring	Joint torique	Junta de tipo O
16	835013M91	1		1	Connector Assy	Ensemble connexion	Conexión, Conj.
17		16	➡ Ref. 16	1	Connector	Connecteur	Conector
18	835024M1	16		1	O-Ring	Joint torique	Junta de tipo O
19	6110582M91	1	Filter Return	1	Hose Assy	Ensemble de flexible	Flexible, Conj.
20	835013M91	1		1	Connector Assy	Ensemble connexion	Conexión, Conj.
21		20	➡ Ref. 20	1	Connector	Connecteur	Conector
22	835024M1	20		1	O-Ring	Joint torique	Junta de tipo O
23	339123X1	1	Spring Anchor M8 x 20	1	Bolt	Boulon	Perno
24	339169X1	1	M8	1	Nut	Écrou	Tuerca



820 860 880
TX760B TX860B
TX870B

803 804 807 808 813 814 815 816 817 841 842 843 844 845

29005C03.1

6199042M3

1

Jan-06

Transmission
Transmission
Transmisión

Oil Strainer
Filtre à tamis
Colador

4 Wheel Drive
4 Roues Motrices
4 ruedas motrices

Carraro
Carraro
Carraro

C-29005-05.1-A

1	6110549M91		Continued	1	Gearbox	Boite de vitesses	Caja de velocidades
2	6194316M1	1	M8 x 18	2	Bolt	Boulon	Perno
3	6194315M1	1		1	Cover, Filter	Couvercle de filtre	Tapa de filtro
4	6194314M1	1		1	O-Ring	Joint torique	Junta de tipo O
5	6194313M1	1		1	Strainer	Crépine	Alcachofa
6	6194311M1	1		1	Plug	Bouchon	Tapón
7	6194312M91	1		1	Kit, Valve	Jeu de soupapes	Juego de válvulas
8	6194317M1	1		1	O-Ring	Joint torique	Junta de tipo O
9	6194318M1	1		1	Cover, Valve	Cache-culbuteurs	Cubre válvula
10	6194319M1	1		1	O-Ring	Joint torique	Junta de tipo O
11	6194320M1	1	Oil Filter	1	Connector	Connecteur	Conector
12	6194321M1	1	7/8	2	Plug	Bouchon	Tapón

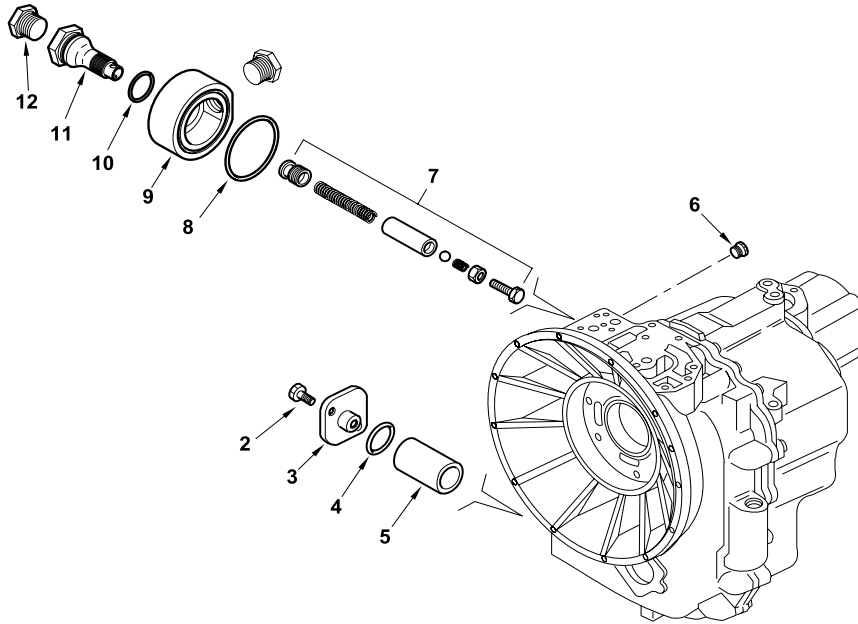

820 860 880
TX760B TX860B
TX870B

803 804 807 808 813 814 815 816 817 841 842 843 844 845

29005C05.1

6199042M3

1

Jan-06

**Transmission
Transmission
Transmisión**

**Output Shaft
Arbre de Sortie
Árbol de salida**

2 Wheel Drive
2 Roues Motrices
2 ruedas motrices

C-29001-07.1-A

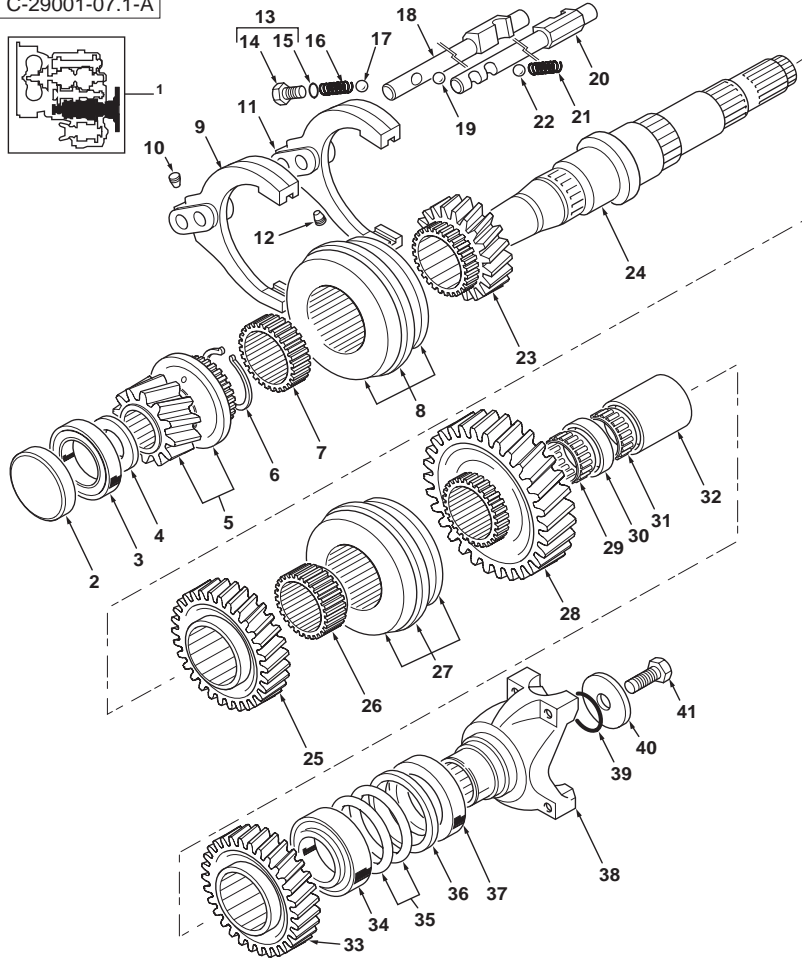

1	6109134M91		Continued 2WS	1	Gearbox	Boite de vitesses	Caja de velocidades
2	6190023M1	1	Continued	1	Cap	Chapeau	Sombbrero
3	6190095M91	1		1	Bearing Assy	Roulement	Rodamiento, Conj.
4	6190076M1	1		1	Washer, Thrust	Rondelle de butée	Arandela de tope
5	6190053M91	1	4th	1	Gear	Pignon	Piñón
6	6190063M1	1		1	Circlip	Segment d'arrêt	Circlip
7	6190025M1	1		1	Sleeve	Chemise	Camisa
8	6190026M91	1		1	Ring, Synchro	Bague synchronisation	Anillo de sincro
9	6190138M1	1	3rd/4th	1	Fork, Shifter	Fourchette	Horquilla
10	6190141M1	1		1	Screw	Vis	Tornillo
11	6190137M1	1	1st/2nd	1	Fork, Shifter	Fourchette	Horquilla
12	6190141M1	1		1	Screw	Vis	Tornillo
13	6190009M91	1		1	Plug Assy	Ensemble bouchons	Tapón, Conj.
14		13	➡ Ref. 13	1	Plug	Bouchon	Tapón
15	6190010M1	13		1	O-Ring	Joint torique	Junta de tipo O
16	6190136M1	1		1	Spring	Ressort	Muelle
17	6190135M1	1		1	Ball	Bille	Bola
18	6190139M91	1	1st/2nd	1	Rail Assy	Ensemble de rail	Carril, Conj.
19	6190135M1	1		1	Ball	Bille	Bola
20	6190140M91	1	3rd/4th	1	Rail Assy	Ensemble de rail	Carril, Conj.
21	6190136M1	1		1	Spring	Ressort	Muelle
22	6190135M1	1		1	Ball	Bille	Bola
23	6190054M1	1	3rd	1	Gear	Pignon	Piñón
24	6190085M1	1		1	Shaft Assy	Ensemble de l'arbre	Árbol, Conj.
25	6190056M1	1	2nd	1	Gear	Pignon	Piñón
26	6190025M1	1		1	Sleeve	Chemise	Camisa
27	6190026M91	1		1	Ring, Synchro	Bague synchronisation	Anillo de sincro
28	6190057M1	1	1st	1	Gear	Pignon	Piñón
29	6190060M1	1		1	Bearing Assy	Roulement	Rodamiento, Conj.
30	6190061M1	1		1	Spacer	Entretoise	Traviesa
31	6190060M1	1		1	Bearing Assy	Roulement	Rodamiento, Conj.
32	6190062M1	1		1	Sleeve	Chemise	Camisa
33	6190058M1	1		1	Gear	Pignon	Piñón
34	6190086M91	1		1	Bearing Assy	Roulement	Rodamiento, Conj.
35	6190088M1	1	0.002"	X	Shim	Cale	Calce
35	6190089M1	1	0.003"	X	Shim	Cale	Calce
35	6190090M1	1	0.007"	X	Shim	Cale	Calce
35	6190091M1	1	0.024"	X	Shim	Cale	Calce
36	6190087M1	1		1	Spacer	Entretoise	Traviesa
37	6190163M1	1		1	Seal, Oil	Joint à huile	Junta de aceite
38	6190119M91	1		1	Yoke, Universal Joint	Chape de cardan	Yugo de cardán
39	6190129M1	1		1	O-Ring	Joint torique	Junta de tipo O
40	6190125M1	1		1	Washer	Rondelle	Arandela
41	6190128M1	1		1	Screw	Vis	Tornillo



820
TX760B TX860B
TX870B

801 802 805 806 809 810 811 812

29001C07.1

6199042M3

1

Jan-06

Transmission
Transmission
Transmisión

Output Shaft
Arbre de Sortie
Árbol de salida

2 Wheel Drive
2 Roues Motrices
2 ruedas motrices

C-29001-07.1-A

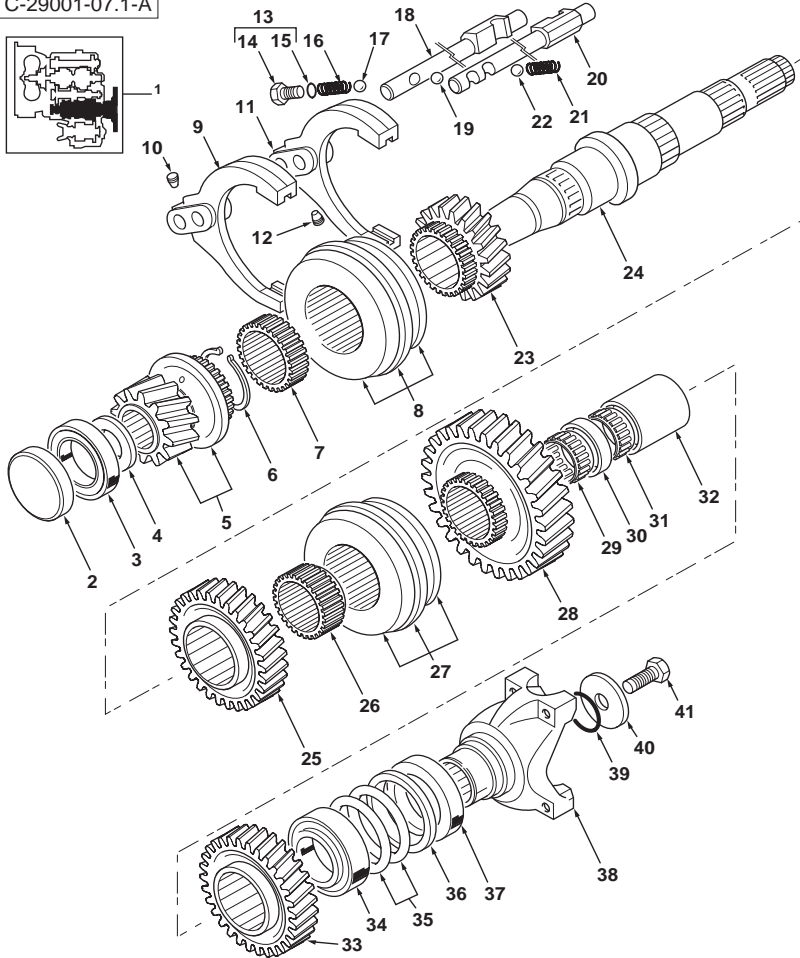

820
TX760B TX860B
TX870B

801 802 805 806 809 810 811 812

29001C07.1

6199042M3

1

Jan-06

**Transmission
Transmission
Transmisión**

**Output Shaft
Arbre de Sortie
Árbol de salida**

**4 Wheel Drive
4 Roues Motrices
4 ruedas motrices**

C-29002-07.1-A

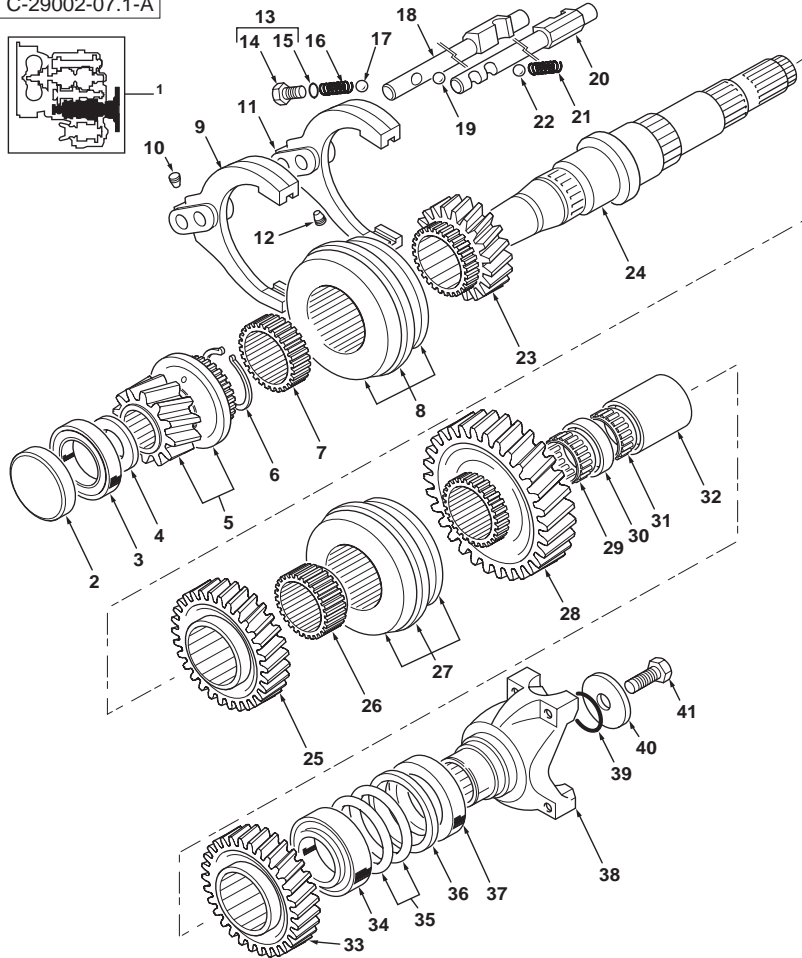

1	6108873M91		Continued 2WS	1	Gearbox	Boite de vitesses	Caja de velocidades
2	6190023M1	1	Continued	1	Cap	Chapeau	Sombbrero
3	6190095M91	1		1	Bearing Assy	Roulement	Rodamiento, Conj.
4	6190076M1	1		1	Washer, Thrust	Rondelle de butée	Arandela de tope
5	6190053M91	1	4th	1	Gear	Pignon	Piñón
6	6190063M1	1		1	Circlip	Segment d'arrêt	Circlip
7	6190025M1	1		1	Sleeve	Chemise	Camisa
8	6190026M91	1		1	Ring, Synchro	Bague synchronisation	Anillo de sincro
9	6190138M1	1	3rd/4th	1	Fork, Shifter	Fourchette	Horquilla
10	6190141M1	1		1	Screw	Vis	Tornillo
11	6190137M1	1	1st/2nd	1	Fork, Shifter	Fourchette	Horquilla
12	6190141M1	1		1	Screw	Vis	Tornillo
13	6190009M91	1		1	Plug Assy	Ensemble bouchons	Tapón, Conj.
14		13	➡ Ref. 13	1	Plug	Bouchon	Tapón
15	6190010M1	13		1	O-Ring	Joint torique	Junta de tipo O
16	6190136M1	1		1	Spring	Ressort	Muelle
17	6190135M1	1		1	Ball	Bille	Bola
18	6190139M91	1	1st/2nd	1	Rail Assy	Ensemble de rail	Carril, Conj.
19	6190135M1	1		1	Ball	Bille	Bola
20	6190140M91	1	3rd/4th	1	Rail Assy	Ensemble de rail	Carril, Conj.
21	6190136M1	1		1	Spring	Ressort	Muelle
22	6190135M1	1		1	Ball	Bille	Bola
23	6190054M1	1	3rd	1	Gear	Pignon	Piñón
24	6190085M1	1		1	Shaft Assy	Ensemble de l'arbre	Árbol, Conj.
25	6190056M1	1	2nd	1	Gear	Pignon	Piñón
26	6190025M1	1		1	Sleeve	Chemise	Camisa
27	6190026M91	1		1	Ring, Synchro	Bague synchronisation	Anillo de sincro
28	6190057M1	1	1st	1	Gear	Pignon	Piñón
29	6190060M1	1		1	Bearing Assy	Roulement	Rodamiento, Conj.
30	6190061M1	1		1	Spacer	Entretoise	Traviesa
31	6190060M1	1		1	Bearing Assy	Roulement	Rodamiento, Conj.
32	6190062M1	1		1	Sleeve	Chemise	Camisa
33	6190058M1	1		1	Gear	Pignon	Piñón
34	6190086M91	1		1	Bearing Assy	Roulement	Rodamiento, Conj.
35	6190088M1	1	0.002"	X	Shim	Cale	Calce
35	6190089M1	1	0.003"	X	Shim	Cale	Calce
35	6190090M1	1	0.007"	X	Shim	Cale	Calce
35	6190091M1	1	0.024"	X	Shim	Cale	Calce
36	6190087M1	1		1	Spacer	Entretoise	Traviesa
37	6190163M1	1		1	Seal, Oil	Joint à huile	Junta de aceite
38	6190119M91	1		1	Yoke, Universal Joint	Chape de cardan	Yugo de cardán
39	6190129M1	1		1	O-Ring	Joint torique	Junta de tipo O
40	6190125M1	1		1	Washer	Rondelle	Arandela
41	6190128M1	1		1	Screw	Vis	Tornillo



820 860 880
TX760B TX860B
TX870B

803 804 807 808 813 814 815 816 817 831 832 833 834 841 842 843 844 845

29002C07.1

6199042M3

1

Jan-06

Transmission
Transmission
Transmisión

Output Shaft
Arbre de Sortie
Árbol de salida

4 Wheel Drive
4 Roues Motrices
4 ruedas motrices

C-29002-07.1-A

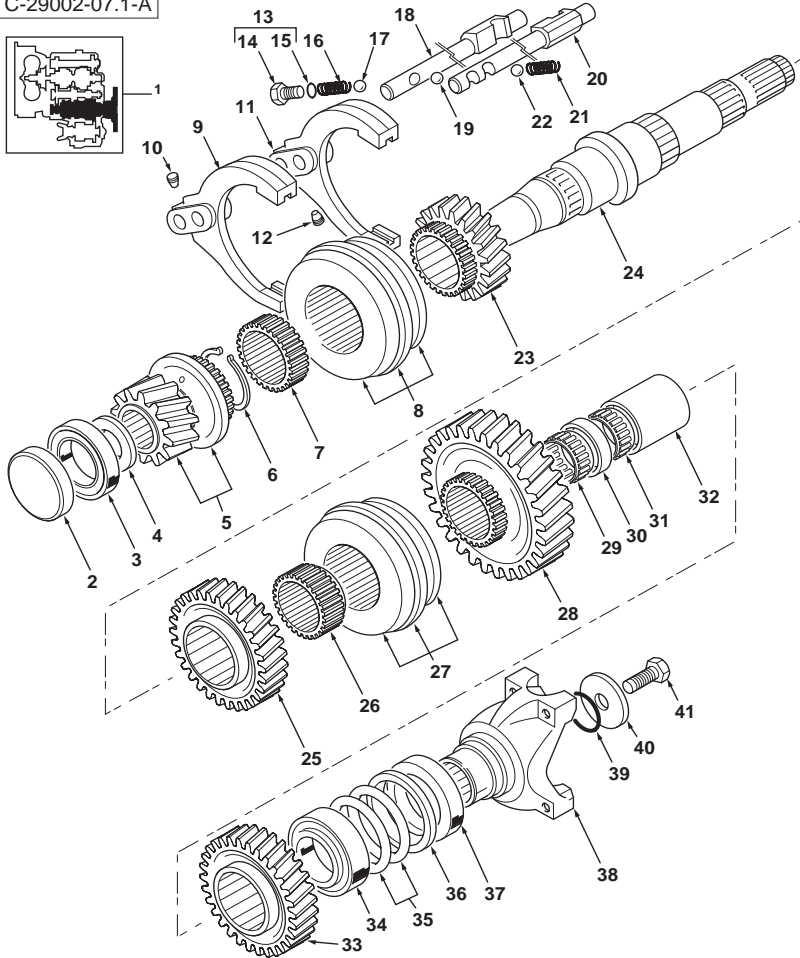

820 860 880
TX760B TX860B
TX870B

803 804 807 808 813 814 815 816 817 831 832 833 834 841 842 843 844 845

29002C07.1

6199042M3

1

Jan-06

Transmission
Transmission
Transmisión

Reverse / First Shaft
Marche Arrière / Arbre Principal
Árbol de marcha atrás/primer

Powershift
Powershift
Powershift

C-29003-08.1-A

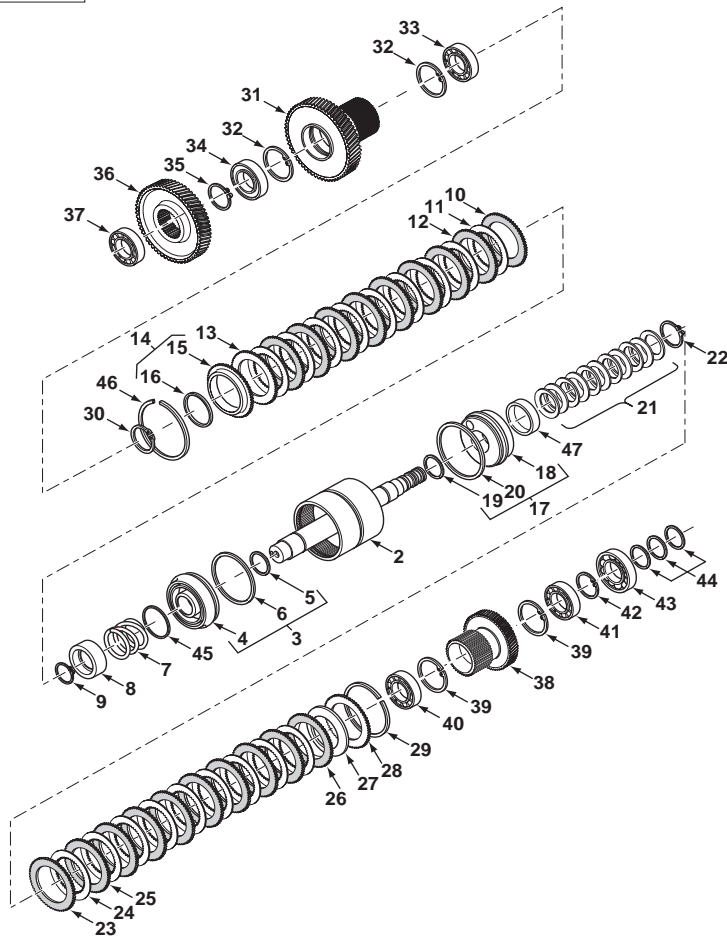

1	6108875M91		Continued 2WS	1	Gearbox	Boite de vitesses	Caja de velocidades
2	6193526M91	1		1	Shaft Assy	Ensemble de l'arbre	Árbol, Conj.
3	6193502M91	1		1	Piston Assy	Ensemble de piston	Pistón, Conj.
4		3	➡ Ref.3	1	Piston	Piston	Pistón
5	6193596M1	3		1	Seal	Joint	Junta
6	6193595M1	3		1	Seal	Joint	Junta
7	6193504M1	1		1	Spring	Ressort	Muelle
8	6193505M1	1		1	Retainer	Dispositif de retenue	Fijación
9	6193506M1	1		1	Ring, Snap	Anneau d'arrêt	Anillo de resorte
10	6193507M1	1		1	Plate, Backing	Plaque d'appui	Placa de apoyo
11	6193508M1	1		8	Disc, Friction	Disque de friction	Disco de fricción
12	6193509M1	1		1	Plate, Intermediate	Plaque intermédiaire	Placa intermediaria
13	6193507M1	1		1	Plate, Backing	Plaque d'appui	Placa de apoyo
14	6193510M1	14		1	Plate	Plaque	Placa
15		14	➡ Ref.14	1	Plate	Plaque	Placa
16	6193598M1	1		1	Seal	Joint	Junta
17	6193502M91	1		1	Piston Assy	Ensemble de piston	Pistón, Conj.
18		17	➡ Ref.17	1	Piston	Piston	Pistón
19	6193596M1	17		1	Seal	Joint	Junta
20	6193595M1	17		1	Seal	Joint	Junta
21	6193469M1	1		1	Spring	Ressort	Muelle
22	6193506M1	1		1	Ring, Snap	Anneau d'arrêt	Anillo de resorte
23	6193507M1	1		1	Plate, Backing	Plaque d'appui	Placa de apoyo
24	6193508M1	1		8	Disc, Friction	Disque de friction	Disco de fricción
25	6193509M1	1		7	Plate, Intermediate	Plaque intermédiaire	Placa intermediaria
26	6193507M1	1		1	Plate, Backing	Plaque d'appui	Placa de apoyo
27	6193528M1	1		1	Spring	Ressort	Muelle
28	6193512M1	1		1	Plate, Backing	Plaque d'appui	Placa de apoyo
29	6193511M1	1		1	Ring, Snap	Anneau d'arrêt	Anillo de resorte
30	6193513M1	1		1	Ring, Snap	Anneau d'arrêt	Anillo de resorte
31	6193514M1	1	54T	1	Gear	Pignon	Piñón
32	6193515M1	1		2	Ring, Snap	Anneau d'arrêt	Anillo de resorte
33	6194063M91	1		1	Bearing Assy	Roulement	Rodamiento, Conj.
34	6193517M91	1		1	Bearing	Coussinet	Cojinete
35	6193513M1	1		1	Ring, Snap	Anneau d'arrêt	Anillo de resorte
36	6194064M1	1	50T	1	Gear	Pignon	Piñón
37	6193519M91	1		1	Bearing	Coussinet	Cojinete
38	6193530M1	1	30T	1	Gear	Pignon	Piñón
39	6193531M1	1		2	Ring, Snap	Anneau d'arrêt	Anillo de resorte
40	6193532M91	1		1	Bearing	Coussinet	Cojinete
41	6193533M91	1		1	Bearing	Coussinet	Cojinete
42	6193534M1	1		1	Ring, Snap	Anneau d'arrêt	Anillo de resorte
43	6193535M91	1		1	Bearing	Coussinet	Cojinete
44	6193525M1	1		3	Ring	Anneau	Aro



860 880
TX860B TX870B

821 822 823 824 825 851 852 853 854 855

29003C08.1

6199042M3

1

Jan-06

Transmission
Transmission
Transmisión

Reverse / First Shaft
Marche Arrière / Arbre Principal
Árbol de marcha atrás/primera

Powershift
Powershift
Powershift

C-29003-08.1-A

45	6193503M1	1		1	Plate	Plaque	Placa
46	6193511M1	1		1	Ring, Snap	Anneau d'arrêt	Anillo de resorte
47	6193527M1	1		1	Spacer	Entretoise	Traviesa

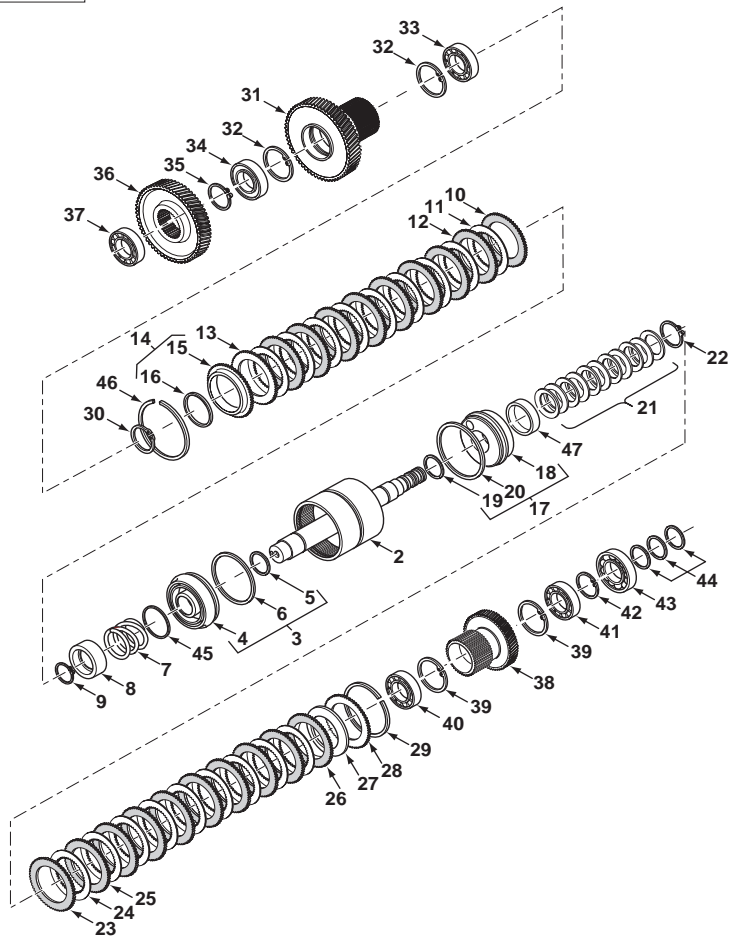

860 880
TX860B TX870B

821 822 823 824 825 851 852 853 854 855

29003C08.1

6199042M3

1

Jan-06

Transmission
Transmission
Transmisión

Reverse / First Shaft
Marche Arrière / Arbre Principal
Árbol de marcha atrás/primer

Powershift
Powershift
Powershift

C-29004-08.1-A

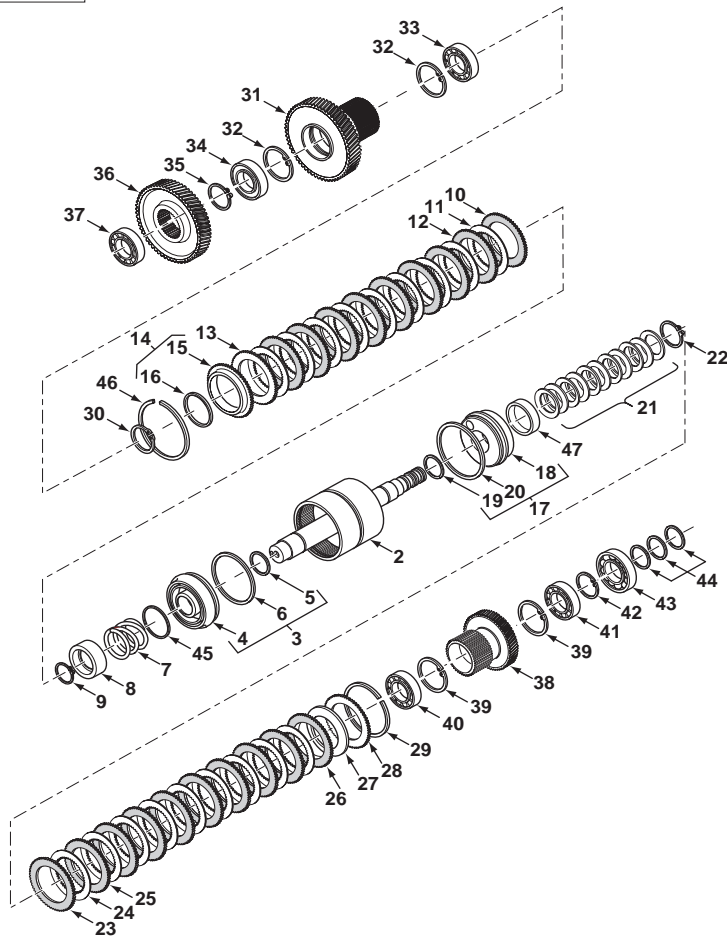

1	6109135M91		Continued 4WS	1	Gearbox	Boite de vitesses	Caja de velocidades
2	6193526M91	1		1	Shaft Assy	Ensemble de l'arbre	Árbol, Conj.
3	6193502M91	1		1	Piston Assy	Ensemble de piston	Pistón, Conj.
4		3	➡ Ref.3	1	Piston	Piston	Pistón
5	6193596M1	3		1	Seal	Joint	Junta
6	6193595M1	3		1	Seal	Joint	Junta
7	6193504M1	1		1	Spring	Ressort	Muelle
8	6193505M1	1		1	Retainer	Dispositif de retenue	Fijación
9	6193506M1	1		1	Ring, Snap	Anneau d'arrêt	Anillo de resorte
10	6193507M1	1		1	Plate, Backing	Plaque d'appui	Placa de apoyo
11	6193508M1	1		8	Disc, Friction	Disque de friction	Disco de fricción
12	6193509M1	1		1	Plate, Intermediate	Plaque intermédiaire	Placa intermediaria
13	6193507M1	1		1	Plate, Backing	Plaque d'appui	Placa de apoyo
14	6193510M1	14		1	Plate	Plaque	Placa
15		14	➡ Ref.14	1	Plate	Plaque	Placa
16	6193598M1	1		1	Seal	Joint	Junta
17	6193502M91	1		1	Piston Assy	Ensemble de piston	Pistón, Conj.
18		17	➡ Ref.17	1	Piston	Piston	Pistón
19	6193596M1	17		1	Seal	Joint	Junta
20	6193595M1	17		1	Seal	Joint	Junta
21	6193469M1	1		1	Spring	Ressort	Muelle
22	6193506M1	1		1	Ring, Snap	Anneau d'arrêt	Anillo de resorte
23	6193507M1	1		1	Plate, Backing	Plaque d'appui	Placa de apoyo
24	6193508M1	1		8	Disc, Friction	Disque de friction	Disco de fricción
25	6193509M1	1		7	Plate, Intermediate	Plaque intermédiaire	Placa intermediaria
26	6193507M1	1		1	Plate, Backing	Plaque d'appui	Placa de apoyo
27	6193528M1	1		1	Spring	Ressort	Muelle
28	6193512M1	1		1	Plate, Backing	Plaque d'appui	Placa de apoyo
29	6193511M1	1		1	Ring, Snap	Anneau d'arrêt	Anillo de resorte
30	6193513M1	1		1	Ring, Snap	Anneau d'arrêt	Anillo de resorte
31	6193514M1	1	54T	1	Gear	Pignon	Piñón
32	6193515M1	1		2	Ring, Snap	Anneau d'arrêt	Anillo de resorte
33	6194063M91	1		1	Bearing Assy	Roulement	Rodamiento, Conj.
34	6193517M91	1		1	Bearing	Coussinet	Cojinete
35	6193513M1	1		1	Ring, Snap	Anneau d'arrêt	Anillo de resorte
36	6194064M1	1	50T	1	Gear	Pignon	Piñón
37	6193519M91	1		1	Bearing	Coussinet	Cojinete
38	6193530M1	1	30T	1	Gear	Pignon	Piñón
39	6193531M1	1		2	Ring, Snap	Anneau d'arrêt	Anillo de resorte
40	6193532M91	1		1	Bearing	Coussinet	Cojinete
41	6193533M91	1		1	Bearing	Coussinet	Cojinete
42	6193534M1	1		1	Ring, Snap	Anneau d'arrêt	Anillo de resorte
43	6193535M91	1		1	Bearing	Coussinet	Cojinete
44	6193525M1	1		3	Ring	Anneau	Aro



970 980
TX970B

921 922 923 931 932

29004C08.1

6199042M3

1

Jan-06

Transmission
Transmission
Transmisión

Reverse / First Shaft
Marche Arrière / Arbre Principal
Árbol de marcha atrás/primera

Powershift
Powershift
Powershift

C-29004-08.1-A

45	6193503M1	1		1	Plate	Plaque	Placa
46	6193511M1	1		1	Ring, Snap	Anneau d'arrêt	Anillo de resorte
47	6193527M1	1		1	Spacer	Entretoise	Traviesa

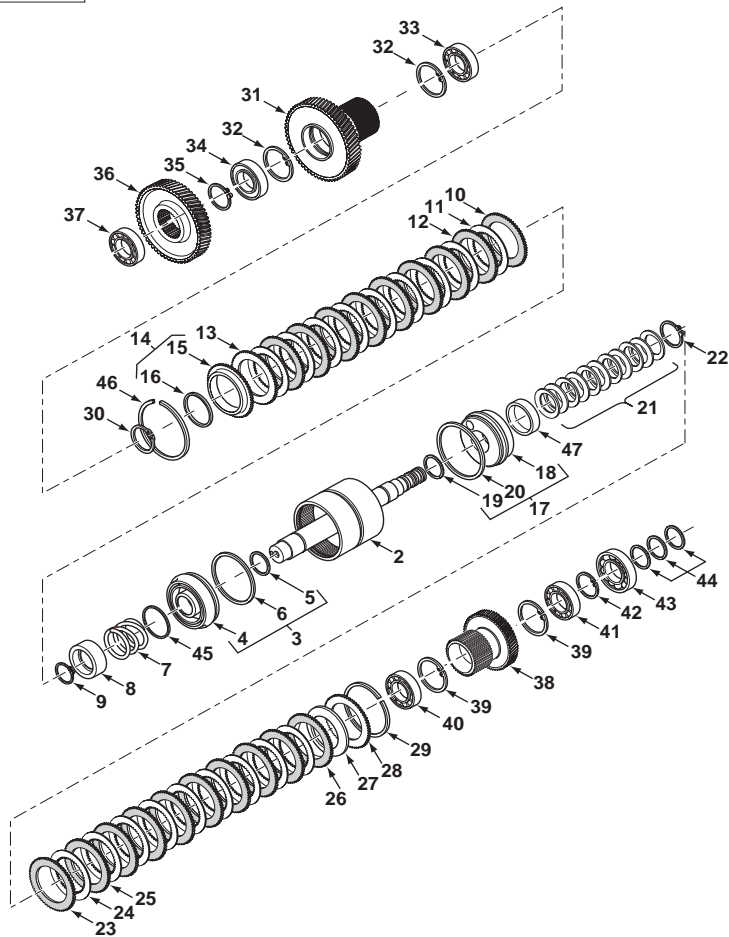

970 980
TX970B

921 922 923 931 932

29004C08.1

6199042M3

1

Jan-06

Transmission
Transmission
Transmisión

Reverse / First Shaft
Marche Arrière / Arbre Principal
Árbol de marcha atrás/primera

4 Wheel Drive
4 Roues Motrices
4 ruedas motrices

Carraro
Carraro
Carraro

C-29005-08.1-A

1	6110549M91		Continued	1	Gearbox	Boite de vitesses	Caja de velocidades
2	6194369M1	1		2	Bearing	Coussinet	Cojinete
3	6194370M1	1	Reverse	1	Shaft	Arbre	Árbol
4	6194371M1	1		1	Bearing	Coussinet	Cojinete
5	6194372M1	1	Primary	1	Shaft	Arbre	Árbol
6	6194373M1	1		1	Bearing	Coussinet	Cojinete

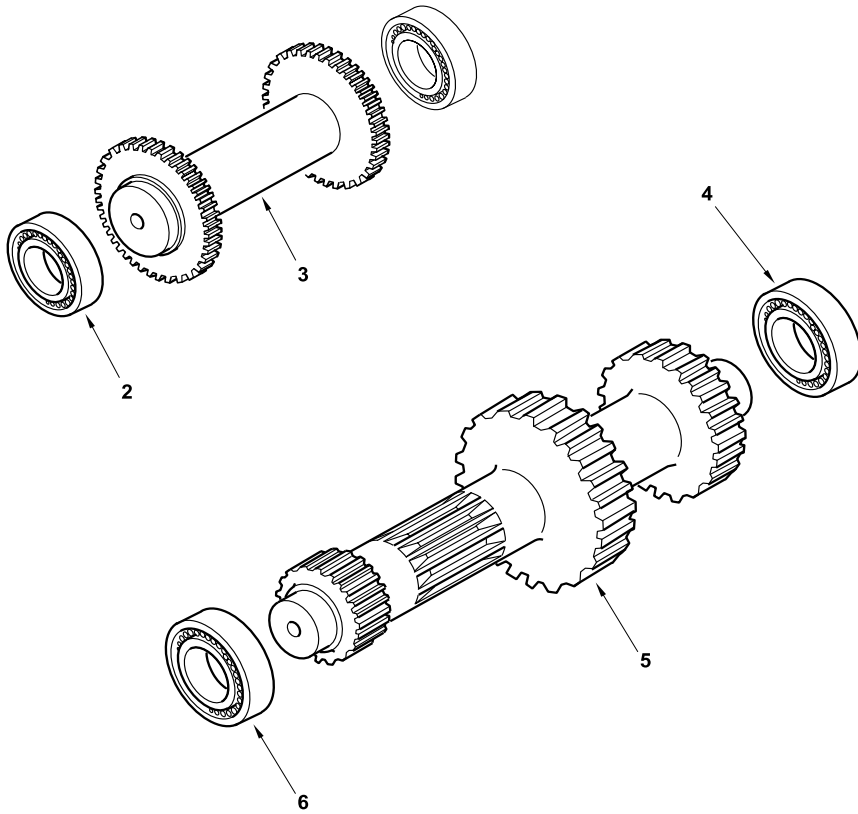

820 860 880
TX760B TX860B
TX870B

803 804 807 808 813 814 815 816 817 841 842 843 844 845

29005C08.1

6199042M3

1

Jan-06

Transmission
Transmission
Transmisión

Reverse Idler Shaft
Arbre de Renvoi Marche Arrière
Árbol de reenvío marcha atrás

2 Wheel Drive
2 Roues Motrices
2 ruedas motrices

C-29001-05.1-A

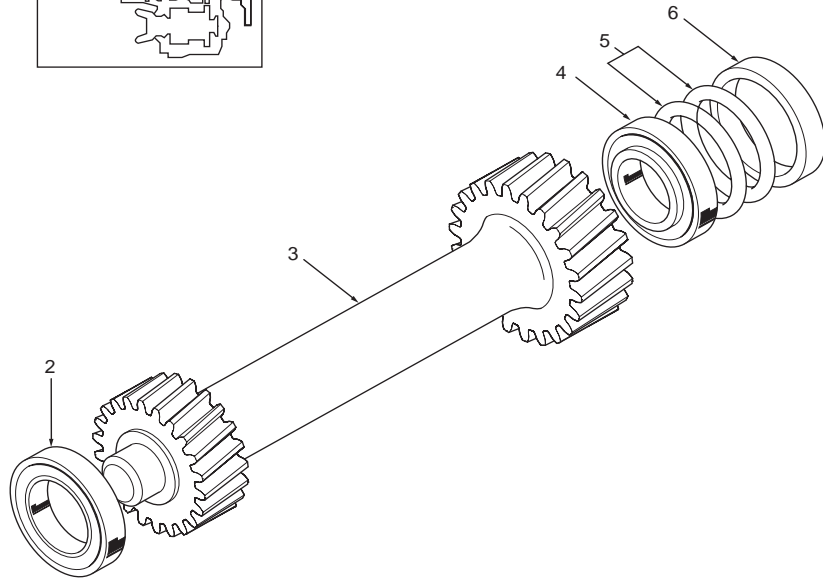
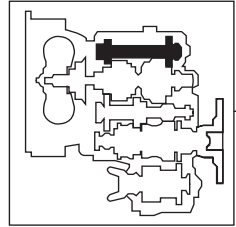

1	6109134M91		Continued 2WS	1	Gearbox	Boite de vitesses	Caja de velocidades
2	6190084M91	1		1	Bearing Assy	Roulement	Rodamiento, Conj.
3	6190819M1	1	20/27	1	Gear	Pignon	Piñón
4	6190084M91	1		1	Bearing Assy	Roulement	Rodamiento, Conj.
5	6190078M1	1	0.002"	X	Shim	Cale	Calce
5	6190079M1	1	0.003"	X	Shim	Cale	Calce
5	6190080M1	1	0.005"	X	Shim	Cale	Calce
5	6190081M1	1	0.007"	X	Shim	Cale	Calce
5	6190082M1	1	0.015"	X	Shim	Cale	Calce
5	6190083M1	1	0.020"	X	Shim	Cale	Calce
6	6190077M1	1		1	Spacer	Entretoise	Traviesa



820
TX760B TX860B
TX870B

801 802 805 806 809 810 811 812

29001C05.1

6199042M3

1

Jan-06

Transmission
Transmission
Transmisión

Reverse Idler Shaft
Arbre de Renvoi Marche Arrière
Árbol de reenvío marcha atrás

4 Wheel Drive
4 Roues Motrices
4 ruedas motrices

C-29001-05.1-A

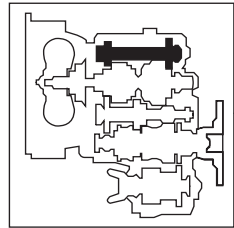

1	6108873M91		Continued 2WS	1	Gearbox	Boite de vitesses	Caja de velocidades
2	6190084M91	1		1	Bearing Assy	Roulement	Rodamiento, Conj.
3	6190819M1	1	20/27	1	Gear	Pignon	Piñón
4	6190084M91	1		1	Bearing Assy	Roulement	Rodamiento, Conj.
5	6190078M1	1	0.002"	X	Shim	Cale	Calce
5	6190079M1	1	0.003"	X	Shim	Cale	Calce
5	6190080M1	1	0.005"	X	Shim	Cale	Calce
5	6190081M1	1	0.007"	X	Shim	Cale	Calce
5	6190082M1	1	0.015"	X	Shim	Cale	Calce
5	6190083M1	1	0.020"	X	Shim	Cale	Calce
6	6190077M1	1		1	Spacer	Entretoise	Traviesa



820 860 880
TX760B TX860B
TX870B

803 804 807 808 813 814 815 816 817 831 832 833 834 841 842 843 844 845

29002C05.1

6199042M3

1

Jan-06

Transmission
Transmission
Transmisión

Second Shaft
Arbre Secondaire
Árbol de segunda

Powershift
Powershift
Powershift

C-29003-10.1-A

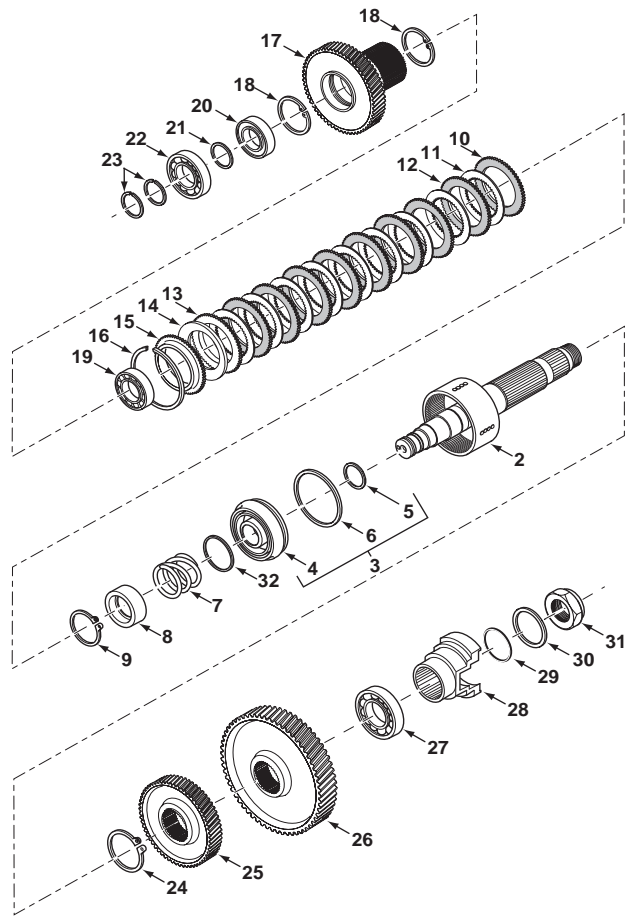

1	6108875M91		Continued 2WS	1	Gearbox	Boite de vitesses	Caja de velocidades
2	6193542M91	1		1	Shaft Assy	Ensemble de l'arbre	Árbol, Conj.
3	6193502M91	1		1	Piston Assy	Ensemble de piston	Pistón, Conj.
4		3	➡ Ref.3	1	Piston	Piston	Pistón
5	6193596M1	3		1	Seal	Joint	Junta
6	6193595M1	3		1	Seal	Joint	Junta
7	6193504M1	1		1	Spring	Ressort	Muelle
8	6193505M1	1		1	Retainer	Dispositif de retenue	Fijación
9	6193506M1	1		1	Ring, Snap	Anneau d'arrêt	Anillo de resorte
10	6193507M1	1		1	Plate, Backing	Plaque d'appui	Placa de apoyo
11	6193508M1	1		8	Disc, Friction	Disque de friction	Disco de fricción
12	6193509M1	1		7	Plate, Intermediate	Plaque intermédiaire	Placa intermediaria
13	6193507M1	1		1	Plate, Backing	Plaque d'appui	Placa de apoyo
14	6193528M1	1		1	Spring	Ressort	Muelle
15	6193512M1	1		1	Plate, Backing	Plaque d'appui	Placa de apoyo
16	6193511M1	1		1	Ring, Snap	Anneau d'arrêt	Anillo de resorte
17	6193543M1	1	52T	1	Gear	Pignon	Piñón
18	6193531M1	1		2	Ring, Snap	Anneau d'arrêt	Anillo de resorte
19	6193532M91	1		1	Bearing	Coussinet	Cojinete
20	6193533M91	1		1	Bearing	Coussinet	Cojinete
21	6193544M1	1		1	Washer	Rondelle	Arandela
22	6193535M91	1		1	Bearing	Coussinet	Cojinete
23	6193525M1	1		2	Ring	Anneau	Aro
24	6193545M1	1		1	Ring, Snap	Anneau d'arrêt	Anillo de resorte
25	6194065M1	1	41T	1	Gear	Pignon	Piñón
26	6193547M1	1	59T	1	Gear	Pignon	Piñón
27	6193548M91	1		1	Bearing	Coussinet	Cojinete
28	6193549M1	1		1	Flange	Flasque	Brida de unión
29	6193550M1	1		1	O-Ring	Joint torique	Junta de tipo O
30	6193551M1	1		1	Washer	Rondelle	Arandela
31	6193552M1	1		1	Nut	Écrou	Tuerca
32	6193503M1	1		1	Plate	Plaque	Placa



860 880
TX860B TX870B

821 822 823 824 825 851 852 853 854 855

29003C10.1

6199042M3

1

Jan-06

Transmission
Transmission
Transmisión

Second Shaft
Arbre Secondaire
Árbol de segunda

Powershift
Powershift
Powershift

C-29003-11.1-A

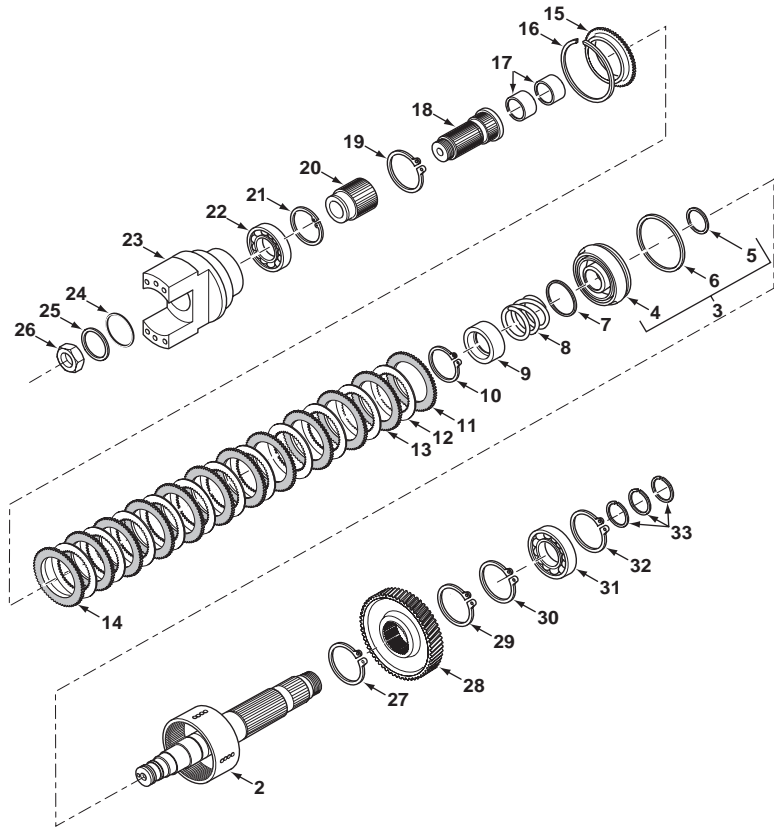

1	6108875M91		Continued 2WS	1	Gearbox	Boite de vitesses	Caja de velocidades
2	6194066M91	1		1	Shaft Assy	Ensemble de l'arbre	Árbol, Conj.
3	6193502M91	1		1	Piston Assy	Ensemble de piston	Pistón, Conj.
4		3	➡ Ref.3	1	Piston	Piston	Pistón
5	6193596M1	3		1	Seal	Joint	Junta
6	6193595M1	3		1	Seal	Joint	Junta
7	6193503M1	1		1	Plate	Plaque	Placa
8	6193504M1	1		1	Spring	Ressort	Muelle
9	6193505M1	1		1	Retainer	Dispositif de retenue	Fijación
10	6193506M1	1		1	Ring, Snap	Anneau d'arrêt	Anillo de resorte
11	6193507M1	1		1	Plate, Backing	Plaque d'appui	Placa de apoyo
12	6193508M1	1		12	Disc, Friction	Disque de friction	Disco de fricción
13	6193509M1	1		11	Plate, Intermediate	Plaque intermédiaire	Placa intermediaria
14	6193507M1	1		1	Plate, Backing	Plaque d'appui	Placa de apoyo
15	6193512M1	1		1	Plate, Backing	Plaque d'appui	Placa de apoyo
16	6193511M1	1		1	Ring, Snap	Anneau d'arrêt	Anillo de resorte
17	6194073M1	1		2	Bushing	Bague	Anillo
18	6194072M91	1		1	Shaft Assy	Ensemble de l'arbre	Árbol, Conj.
19	6193545M1	1		1	Ring, Snap	Anneau d'arrêt	Anillo de resorte
20	6194074M1	1		1	Hub	Moyeu	Cubo
21	6194075M1	1		1	Ring, Snap	Anneau d'arrêt	Anillo de resorte
22	6194076M91	1		1	Bearing Assy	Roulement	Rodamiento, Conj.
23	6193549M1	1		1	Flange	Flasque	Brida de unión
24	6193550M1	1		1	O-Ring	Joint torique	Junta de tipo O
25	6193551M1	1		1	Washer	Rondelle	Arandela
26	6193552M1	1		1	Nut	Écrou	Tuerca
27	6194067M1	1		1	Ring, Snap	Anneau d'arrêt	Anillo de resorte
28	6194068M1	1	39T	1	Gear	Pignon	Piñón
29	6194067M1	1		1	Ring, Snap	Anneau d'arrêt	Anillo de resorte
30	6194069M1	1		1	Ring, Snap	Anneau d'arrêt	Anillo de resorte
31	6194070M91	1		1	Bearing Assy	Roulement	Rodamiento, Conj.
32	6194069M1	1		1	Ring, Snap	Anneau d'arrêt	Anillo de resorte
33	6194071M1	1		3	Ring, Piston	Segment de piston	Segmento de pistón



860 880
TX860B TX870B

821 822 823 824 825 851 852 853 854 855

29003C11.1

6199042M3

1

Jan-06

Transmission
Transmission
Transmisión

Second Shaft
Arbre Secondaire
Árbol de segunda

Powershift
Powershift
Powershift

C-29004-10.1-A

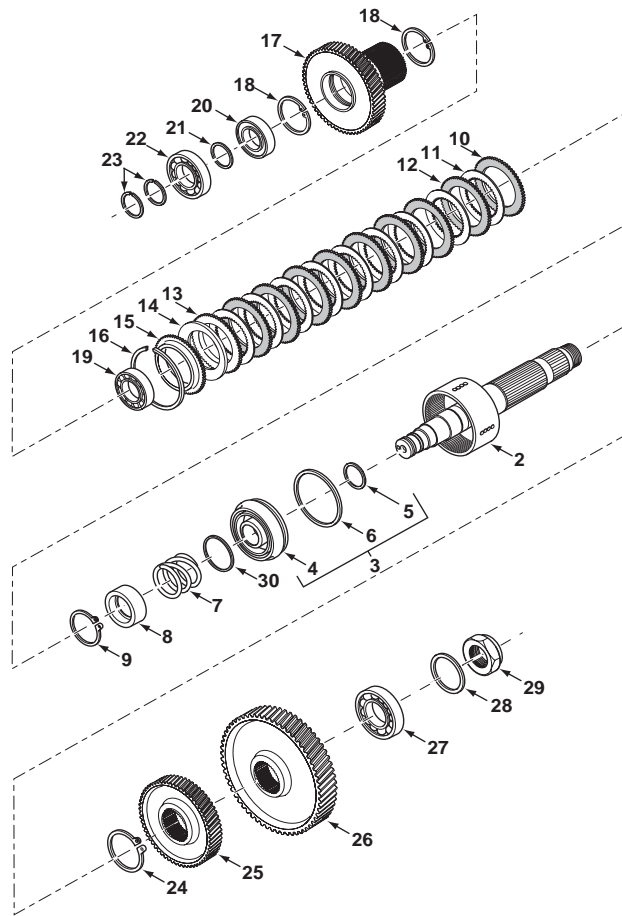

1	6109135M91		Continued 4WS	1	Gearbox	Boite de vitesses	Caja de velocidades
2	6194087M91	1		1	Shaft Assy	Ensemble de l'arbre	Árbol, Conj.
3	6193502M91	1		1	Piston Assy	Ensemble de piston	Pistón, Conj.
4		3	➡ Ref.3	1	Piston	Piston	Pistón
5	6193596M1	3		1	Seal	Joint	Junta
6	6193595M1	3		1	Seal	Joint	Junta
7	6193504M1	1		1	Spring	Ressort	Muelle
8	6193505M1	1		1	Retainer	Dispositif de retenue	Fijación
9	6193506M1	1		1	Ring, Snap	Anneau d'arrêt	Anillo de resorte
10	6193507M1	1		1	Plate, Backing	Plaque d'appui	Placa de apoyo
11	6193508M1	1		8	Disc, Friction	Disque de friction	Disco de fricción
12	6193509M1	1		7	Plate, Intermediate	Plaque intermédiaire	Placa intermediaria
13	6193507M1	1		1	Plate, Backing	Plaque d'appui	Placa de apoyo
14	6193528M1	1		1	Spring	Ressort	Muelle
15	6193512M1	1		1	Plate, Backing	Plaque d'appui	Placa de apoyo
16	6193511M1	1		1	Ring, Snap	Anneau d'arrêt	Anillo de resorte
17	6193543M1	1	52T	1	Gear	Pignon	Piñón
18	6193531M1	1		2	Ring, Snap	Anneau d'arrêt	Anillo de resorte
19	6193532M91	1		1	Bearing	Coussinet	Cojinete
20	6193533M91	1		1	Bearing	Coussinet	Cojinete
21	6193544M1	1		1	Washer	Rondelle	Arandela
22	6193535M91	1		1	Bearing	Coussinet	Cojinete
23	6193525M1	1		2	Ring	Anneau	Aro
24	6193545M1	1		1	Ring, Snap	Anneau d'arrêt	Anillo de resorte
25	6194065M1	1	41T	1	Gear	Pignon	Piñón
26	6193547M1	1	59T	1	Gear	Pignon	Piñón
27	6193548M91	1		1	Bearing	Coussinet	Cojinete
28	6193551M1	1		1	Washer	Rondelle	Arandela
29	6193552M1	1		1	Nut	Écrou	Tuerca
30	6193503M1	1		1	Plate	Plaque	Placa



970 980
TX970B

921 922 923 931 932

29004C10.1

6199042M3

1

Jan-06

Transmission
Transmission
Transmisión

Second Shaft
Arbre Secondaire
Árbol de segunda

Powershift
Powershift
Powershift

C-29004-11.1-A

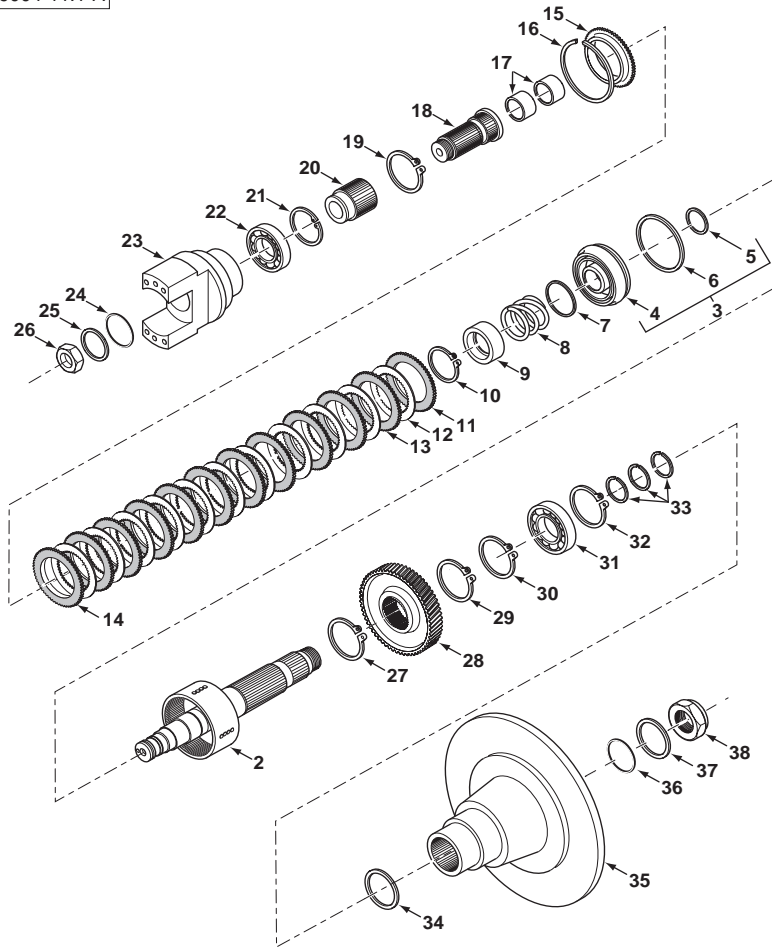

1	6109135M91		Continued 4WS	1	Gearbox	Boite de vitesses	Caja de velocidades
2	6194088M91	1		1	Shaft Assy	Ensemble de l'arbre	Árbol, Conj.
3	6193502M91	1		1	Piston Assy	Ensemble de piston	Pistón, Conj.
4		3	➡ Ref.3	1	Piston	Piston	Pistón
5	6193596M1	3		1	Seal	Joint	Junta
6	6193595M1	3		1	Seal	Joint	Junta
7	6193503M1	1		1	Plate	Plaque	Placa
8	6193504M1	1		1	Spring	Ressort	Muelle
9	6193505M1	1		1	Retainer	Dispositif de retenue	Fijación
10	6193506M1	1		1	Ring, Snap	Anneau d'arrêt	Anillo de resorte
11	6193507M1	1		1	Plate, Backing	Plaque d'appui	Placa de apoyo
12	6193508M1	1		12	Disc, Friction	Disque de friction	Disco de fricción
13	6193509M1	1		11	Plate, Intermediate	Plaque intermédiaire	Placa intermediaria
14	6193507M1	1		1	Plate, Backing	Plaque d'appui	Placa de apoyo
15	6193512M1	1		1	Plate, Backing	Plaque d'appui	Placa de apoyo
16	6193511M1	1		1	Ring, Snap	Anneau d'arrêt	Anillo de resorte
17	6194073M1	1		2	Bushing	Bague	Anillo
18	6194072M91	1		1	Shaft Assy	Ensemble de l'arbre	Árbol, Conj.
19	6193545M1	1		1	Ring, Snap	Anneau d'arrêt	Anillo de resorte
20	6194074M1	1		1	Hub	Moyeu	Cubo
21	6194075M1	1		1	Ring, Snap	Anneau d'arrêt	Anillo de resorte
22	6194076M91	1		1	Bearing Assy	Roulement	Rodamiento, Conj.
23	6193549M1	1		1	Flange	Flasque	Brida de unión
24	6193550M1	1		1	O-Ring	Joint torique	Junta de tipo O
25	6193551M1	1		1	Washer	Rondelle	Arandela
26	6193552M1	1		1	Nut	Écrou	Tuerca
27	6194067M1	1		1	Ring, Snap	Anneau d'arrêt	Anillo de resorte
28	6194068M1	1	39T	1	Gear	Pignon	Piñón
29	6194067M1	1		1	Ring, Snap	Anneau d'arrêt	Anillo de resorte
30	6194069M1	1		1	Ring, Snap	Anneau d'arrêt	Anillo de resorte
31	6194070M91	1		1	Bearing Assy	Roulement	Rodamiento, Conj.
32	6194069M1	1		1	Ring, Snap	Anneau d'arrêt	Anillo de resorte
33	6194071M1	1		3	Ring, Piston	Segment de piston	Segmento de pistón
34	6194089M1	1		1	Spacer	Entretoise	Traviesa
35	6193549M1	1		1	Flange	Flasque	Brida de unión
36	6193550M1	1		1	O-Ring	Joint torique	Junta de tipo O
37	6193551M1	1		1	Washer	Rondelle	Arandela
38	6193552M1	1		1	Nut	Écrou	Tuerca



970 980
TX970B

921 922 923 931 932

29004C11.1

6199042M3

1

Jan-06

Transmission
Transmission
Transmisión

Second Shaft
Arbre Secondaire
Árbol de segunda

4 Wheel Drive
4 Roues Motrices
4 ruedas motrices

Carraro
Carraro
Carraro

C-29005-09.1-A

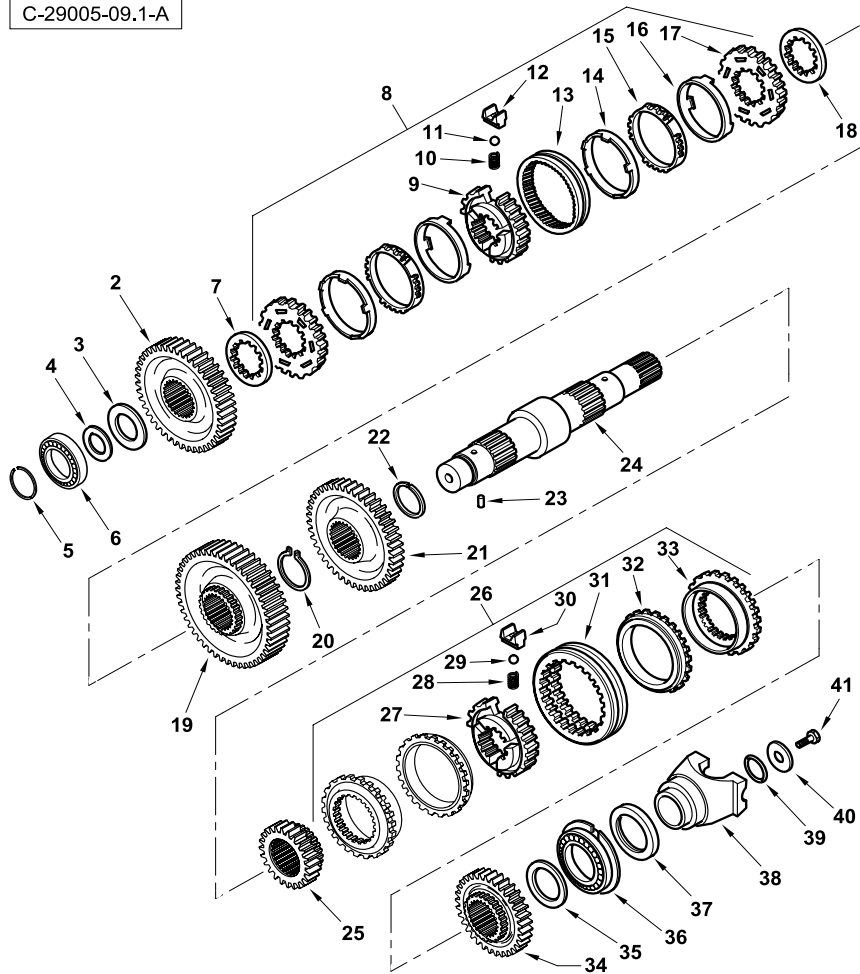

1	6110549M91		Continued	1	Gearbox	Boîte de vitesses	Caja de velocidades
2	6194374M1	1		1	Gear	Pignon	Piñón
3	6194375M1	1		1	Washer, Thrust	Rondelle de butée	Arandela de tope
4	6194376M1	1	0,05 mm	X	Shim	Cale	Calce
4	6194377M1	1	0,10 mm	X	Shim	Cale	Calce
4	6194378M1	1	0,30 mm	X	Shim	Cale	Calce
4	6194379M1	1	0,50 mm	X	Shim	Cale	Calce
5	6194380M1	1	40 mm	1	Ring, Retaining	Anneau de retenue	Anillo de retención
6	6194373M1	1		1	Bearing	Coussinet	Cojinete
7	6194381M1	1		1	Spacer	Entretoise	Traviesa
8	6194391M91	1		1	Kit, Synchro	Jeu de synchronisation	Juego de sincro
9	6194385M1	8		1	Hub	Moyeu	Cubo
10	6194384M1	8		1	Spring	Ressort	Muelle
11	6194389M1	8		1	Ball	Bille	Bola
12	6194388M1	8		1	Plate, Locking	Plaque d'arrêt	Placa de bloqueo
13	6194390M1	8		1	Sleeve	Chemise	Camisa
14	6194382M1	8		2	Ring	Anneau	Aro
15	6194386M1	8		2	Ring	Anneau	Aro
16	6194387M1	8		2	Ring	Anneau	Aro
17	6194383M1	8		2	Ring, Synchro	Bague synchronisation	Anillo de sincro
18	6194381M1	1		1	Spacer	Entretoise	Traviesa
19	6194392M1	1		1	Gear	Pignon	Piñón
20	6194413M1	1		1	Ring, Retaining	Anneau de retenue	Anillo de retención
21	6194412M1	1		1	Gear	Pignon	Piñón
22	6194411M1	1		1	Ring, Retaining	Anneau de retenue	Anillo de retención
23	6194365M1	1		1	Pin, Roll	Goupille élastique	Pasador elástico
24	6194394M1	1	Secondary	1	Shaft	Arbre	Árbol
25	6194393M1	1		1	Gear	Pignon	Piñón
26	6194402M91	1		1	Kit, Synchro	Jeu de synchronisation	Juego de sincro
27	6194396M1	26		1	Hub	Moyeu	Cubo
28	6194400M1	26		1	Spring	Ressort	Muelle
29	6194399M1	26		1	Ball	Bille	Bola
30	6194398M1	26		1	Plate, Locking	Plaque d'arrêt	Placa de bloqueo
31	6194401M1	26		1	Sleeve	Chemise	Camisa
32	6194397M1	26		2	Ring, Special	Jonc	Junquillo
33	6194395M1	26	Clutch	2	Ring	Anneau	Aro
34	6194410M1	1		1	Gear	Pignon	Piñón
35	6194409M1	1		1	Washer, Thrust	Rondelle de butée	Arandela de tope
36	6194408M1	1		1	Bearing	Coussinet	Cojinete
37	6194407M1	1		1	Seal, Oil	Joint à huile	Junta de aceite
38	6194406M1	1		1	Flange	Flasque	Brida de unión
39	6194405M1	1		1	O-Ring	Joint torique	Junta de tipo O
40	6194404M1	1		1	Washer	Rondelle	Arandela
41	6194403M1	1	M12 x 25	1	Bolt	Boulon	Perno



820 860 880
TX760B TX860B
TX870B

803 804 807 808 813 814 815 816 817 841 842 843 844 845

29005C09.1

6199042M3

1

Jan-06

Transmission
Transmission
Transmisión

Second Shaft
Arbre Secondaire
Árbol de segunda

4 Wheel Drive
4 Roues Motrices
4 ruedas motrices

Carraro
Carraro
Carraro

C-29005-09.1-A

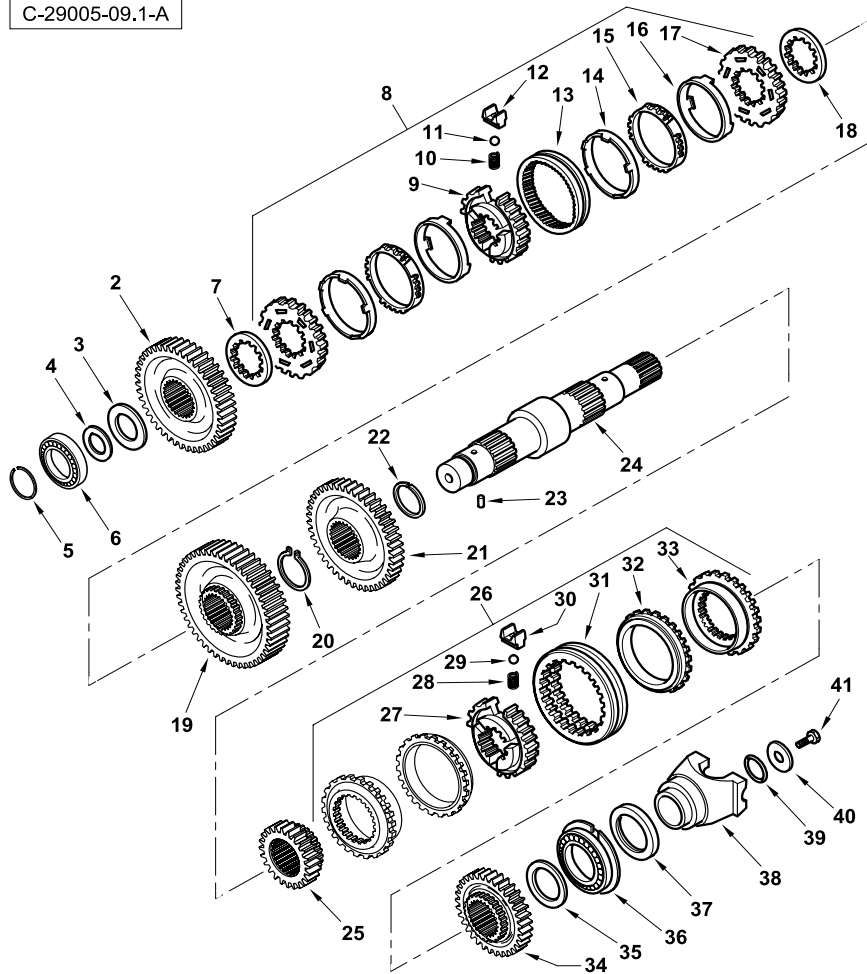

820 860 880
TX760B TX860B
TX870B

803 804 807 808 813 814 815 816 817 841 842 843 844 845

29005C09.1

6199042M3

1

Jan-06

Transmission
Transmission
Transmisión

Solenoid Valve
Électrovanne
Electroválvula

4 Wheel Drive
4 Roues Motrices
4 ruedas motrices

Carraro
Carraro
Carraro

C-29005-13.1-A

1	6110549M91		Continued	1	Gearbox	Boite de vitesses	Caja de velocidades
2	6194488M1	1		1	Valve, Solenoid	Électrovalve	Electroválvula
3	6194328M1	1		1	Plug	Bouchon	Tapón
4	6194329M1	1	10 x 14 x 1,5	1	Washer, Copper	Rondelle, cuivre	Arandela, cobre
5	6194308M1	1	M8 x 60	3	Screw	Vis	Tornillo
6	6194490M1	1		1	Housing	Carter	Cárter
7	6194491M1	1		1	Valve	Soupape	Válvula
8	6194489M1	1		1	Gasket	Joint	Empaquetadura

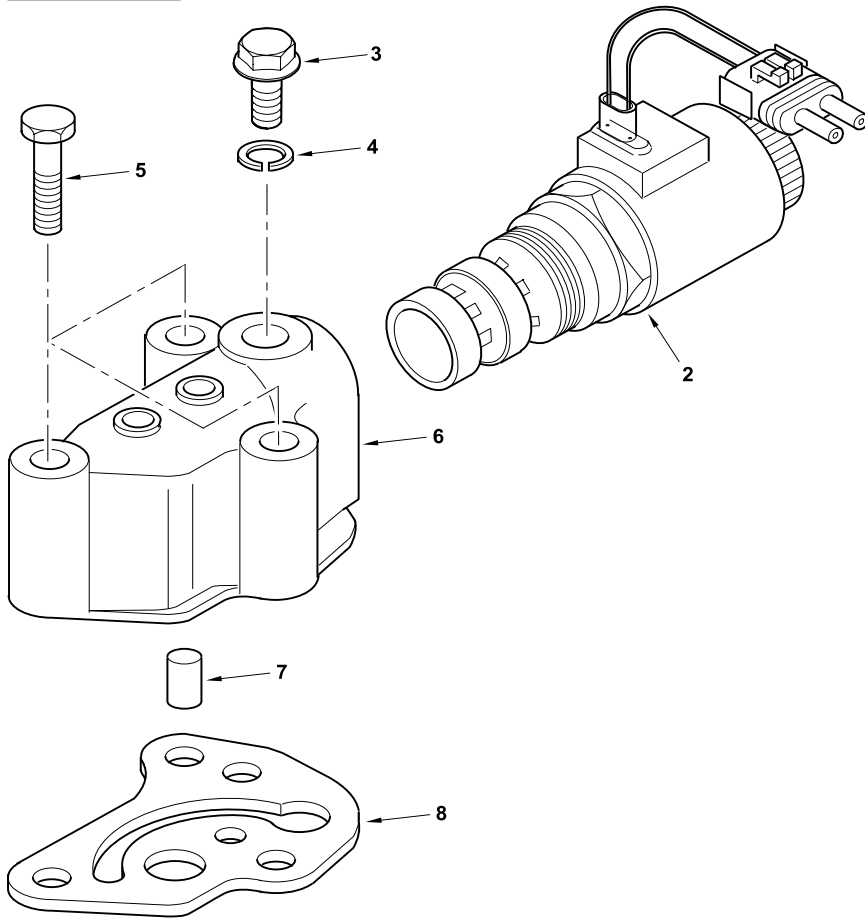

820 860 880
TX760B TX860B
TX870B

803 804 807 808 813 814 815 816 817 841 842 843 844 845

29005C13.1

6199042M3

1

Jan-06

P - Engine and Ancillary Equipment • Moteur et auxiliaires • Motor y equipos auxiliares

Cooling System	25010C01.1	Système de Refroidissement	Refrigeración
Cooling System	25011C01.1	Système de Refroidissement	Refrigeración
Cooling System	25012C01.1	Système de Refroidissement	Refrigeración
Cooling System - Radiator Assembly	25010C02.1	Système de Refroidissement - Montage de Radiateur	Refrigeración - Conjunto de radiador
Cooling System - Radiator Assembly	25011C02.1	Système de Refroidissement - Montage de Radiateur	Refrigeración - Conjunto de radiador
Cooling System - Radiator Assembly	25012C02.1	Système de Refroidissement - Montage de Radiateur	Refrigeración - Conjunto de radiador
Engine - Alternator And Mounting	21010C21.1	Moteur - Fixation de L'alternateur	Motor - Fijación alternador
Engine - Alternator And Mounting	21011C21.1	Moteur - Fixation de L'alternateur	Motor - Fijación alternador
Engine - Alternator And Mounting	21012C21.1	Moteur - Fixation de L'alternateur	Motor - Fijación alternador
Engine - Alternator And Mounting	21013C21.1	Moteur - Fixation de L'alternateur	Motor - Fijación alternador
Engine - Camshaft.....	21010C06.1	Moteur - Arbre à Cames	Motor - Árbol de levas
Engine - Camshaft.....	21011C06.1	Moteur - Arbre à Cames	Motor - Árbol de levas
Engine - Camshaft.....	21012C06.1	Moteur - Arbre à Cames	Motor - Árbol de levas
Engine - Camshaft.....	21013C06.1	Moteur - Arbre à Cames	Motor - Árbol de levas
Engine - Crankshaft Pulley	21010C12.1	Moteur - Poulie de Vilebrequin	Motor - Polea de cigüeñal
Engine - Crankshaft Pulley	21011C12.1	Moteur - Poulie de Vilebrequin	Motor - Polea de cigüeñal
Engine - Crankshaft Pulley	21012C12.1	Moteur - Poulie de Vilebrequin	Motor - Polea de cigüeñal
Engine - Crankshaft Pulley	21013C12.1	Moteur - Poulie de Vilebrequin	Motor - Polea de cigüeñal
Engine - Cylinder Block	21010C02.1	Moteur - Bloc Cylindres	Motor - Bloque cilindros
Engine - Cylinder Block	21011C02.1	Moteur - Bloc Cylindres	Motor - Bloque cilindros
Engine - Cylinder Block	21012C02.1	Moteur - Bloc Cylindres	Motor - Bloque cilindros
Engine - Cylinder Block	21013C02.1	Moteur - Bloc Cylindres	Motor - Bloque cilindros
Engine - Cylinder Head	21010C04.1	Moteur - Culasse	Motor - Culata
Engine - Cylinder Head	21011C04.1	Moteur - Culasse	Motor - Culata
Engine - Cylinder Head	21012C04.1	Moteur - Culasse	Motor - Culata
Engine - Cylinder Head	21013C04.1	Moteur - Culasse	Motor - Culata
Engine - Engine Installation.....	21010C01.1	Moteur - Montage du Moteur	Motor - Instalación motor
Engine - Engine Installation.....	21011C01.1	Moteur - Montage du Moteur	Motor - Instalación motor
Engine - Engine Installation.....	21012C01.1	Moteur - Montage du Moteur	Motor - Instalación motor
Engine - Engine Installation.....	21013C01.1	Moteur - Montage du Moteur	Motor - Instalación motor
Engine - Engine Lifting	21010C23.1	Moteur - Levage Moteur Thermique	Motor - Placas levantadoras del motor térmico
Engine - Engine Lifting	21011C23.1	Moteur - Levage Moteur Thermique	Motor - Placas levantadoras del motor térmico
Engine - Engine Lifting	21012C23.1	Moteur - Levage Moteur Thermique	Motor - Placas levantadoras del motor térmico
Engine - Engine Lifting	21013C23.1	Moteur - Levage Moteur Thermique	Motor - Placas levantadoras del motor térmico
Engine - Exhaust Pipe.....	21010C09.1	Moteur - Collecteur d'échappement	Motor - Colector de escape
Engine - Exhaust Pipe.....	21011C09.1	Moteur - Collecteur d'échappement	Motor - Colector de escape
Engine - Exhaust Pipe.....	21012C09.1	Moteur - Collecteur d'échappement	Motor - Colector de escape
Engine - Exhaust Pipe.....	21013C09.1	Moteur - Collecteur d'échappement	Motor - Colector de escape



P - Engine and Ancillary Equipment • Moteur et auxiliaires • Motor y equipos auxiliares

Engine - Filter With Fuel Separator	21010C20.1	Moteur - Filtre/Séparateur de Carburant	Motor - Filtro/separador de carburante
Engine - Filter With Fuel Separator	21011C20.1	Moteur - Filtre/Séparateur de Carburant	Motor - Filtro/separador de carburante
Engine - Filter With Fuel Separator	21012C20.1	Moteur - Filtre/Séparateur de Carburant	Motor - Filtro/separador de carburante
Engine - Filter With Fuel Separator	21013C20.1	Moteur - Filtre/Séparateur de Carburant	Motor - Filtro/separador de carburante
Engine - Flywheel	21010C13.1	Moteur - Volant Moteur	Motor - Volante
Engine - Flywheel	21011C13.1	Moteur - Volant Moteur	Motor - Volante
Engine - Flywheel	21012C13.1	Moteur - Volant Moteur	Motor - Volante
Engine - Flywheel	21013C13.1	Moteur - Volant Moteur	Motor - Volante
Engine - Flywheel Housing	21010C14.1	Moteur - Volant Moteur Carter	Motor - Volante Cárter
Engine - Flywheel Housing	21011C14.1	Moteur - Volant Moteur Carter	Motor - Volante Cárter
Engine - Flywheel Housing	21012C14.1	Moteur - Volant Moteur Carter	Motor - Volante Cárter
Engine - Flywheel Housing	21013C14.1	Moteur - Volant Moteur Carter	Motor - Volante Cárter
Engine - Fuel Lift Pump	21010C19.1	Moteur - Pompe d'alimentation de Carburant	Motor - Bomba de alimentación de carburante
Engine - Fuel Lift Pump	21011C19.1	Moteur - Pompe d'alimentation de Carburant	Motor - Bomba de alimentación de carburante
Engine - Fuel Lift Pump	21012C19.1	Moteur - Pompe d'alimentation de Carburant	Motor - Bomba de alimentación de carburante
Engine - Fuel Lift Pump	21013C19.1	Moteur - Pompe d'alimentation de Carburant	Motor - Bomba de alimentación de carburante
Engine - Fuel System	21010C18.1	Moteur - Circuit Carburant	Motor - Circuito carburante
Engine - Fuel System	21011C18.1	Moteur - Circuit Carburant	Motor - Circuito carburante
Engine - Fuel System	21012C18.1	Moteur - Circuit Carburant	Motor - Circuito carburante
Engine - Fuel System	21013C18.1	Moteur - Circuit Carburant	Motor - Circuito carburante
Engine - Glow Plugs	21010C22.1	Moteur Thermique - Bougie réchauffage	Motor térmico - Bujía, Calentamiento
Engine - Glow Plugs	21011C22.1	Moteur Thermique - Bougie réchauffage	Motor térmico - Bujía, Calentamiento
Engine - Glow Plugs	21012C22.1	Moteur Thermique - Bougie réchauffage	Motor térmico - Bujía, Calentamiento
Engine - Glow Plugs	21013C22.1	Moteur Thermique - Bougie réchauffage	Motor térmico - Bujía, Calentamiento
Engine - Joints And Gaskets	21010C25.1	Moteur - Joints	Motor - Juntas
Engine - Joints And Gaskets	21010C26.1	Moteur - Joints	Motor - Juntas
Engine - Joints And Gaskets	21011C25.1	Moteur - Joints	Motor - Juntas
Engine - Joints And Gaskets	21011C26.1	Moteur - Joints	Motor - Juntas
Engine - Joints And Gaskets	21012C25.1	Moteur - Joints	Motor - Juntas
Engine - Joints And Gaskets	21012C26.1	Moteur - Joints	Motor - Juntas
Engine - Joints And Gaskets	21013C25.1	Moteur - Joints	Motor - Juntas
Engine - Joints And Gaskets	21013C26.1	Moteur - Joints	Motor - Juntas
Engine - Lubricating Oil Filler And Breather	21010C07.1	Moteur - Remplisseur d'huile et Reniflard	Motor - Respiradero y tubo de llenado del aceite lubricante
Engine - Lubricating Oil Filler And Breather	21011C07.1	Moteur - Remplisseur d'huile et Reniflard	Motor - Respiradero y tubo de llenado del aceite lubricante
Engine - Lubricating Oil Filler And Breather	21012C07.1	Moteur - Remplisseur d'huile et Reniflard	Motor - Respiradero y tubo de llenado del aceite lubricante
Engine - Lubricating Oil Filler And Breather	21013C07.1	Moteur - Remplisseur d'huile et Reniflard	Motor - Respiradero y tubo de llenado del aceite lubricante
Engine - Lubricating Oil Filter And Integral Oil Cooler	21010C16.1	Moteur - Filtre à Huile et Refroidisseur d'huile	Motor - Filtro y enfriador integral de aceite
Engine - Lubricating Oil Filter And Integral Oil Cooler	21011C16.1	Moteur - Filtre à Huile et Refroidisseur d'huile	Motor - Filtro y enfriador integral de aceite



P - Engine and Ancillary Equipment • Moteur et auxiliaires • Motor y equipos auxiliares

Engine - Lubricating Oil Filter And Integral Oil Cooler.....21012C16.1	Moteur - Filtre à Huile et Refroidisseur d'huile	Motor - Filtro y enfriador integral de aceite
Engine - Lubricating Oil Filter And Integral Oil Cooler.....21013C16.1	Moteur - Filtre à Huile et Refroidisseur d'huile	Motor - Filtro y enfriador integral de aceite
Engine - Oil Pan21010C15.1	Moteur - Carter d'huile	Motor - Cáster de aceite
Engine - Oil Pan21011C15.1	Moteur - Carter d'huile	Motor - Cáster de aceite
Engine - Oil Pan21012C15.1	Moteur - Carter d'huile	Motor - Cáster de aceite
Engine - Oil Pan21013C15.1	Moteur - Carter d'huile	Motor - Cáster de aceite
Engine - Oil Pump21010C17.1	Moteur - Pompe à Huile	Motor - Bomba de aceite
Engine - Oil Pump21011C17.1	Moteur - Pompe à Huile	Motor - Bomba de aceite
Engine - Oil Pump21012C17.1	Moteur - Pompe à Huile	Motor - Bomba de aceite
Engine - Oil Pump21013C17.1	Moteur - Pompe à Huile	Motor - Bomba de aceite
Engine - Pistons And Crankshaft.....21010C03.1	Moteur - Pistons et Vilebrequin	Motor - Pistones y cigüeñal
Engine - Pistons And Crankshaft.....21011C03.1	Moteur - Pistons et Vilebrequin	Motor - Pistones y cigüeñal
Engine - Pistons And Crankshaft.....21012C03.1	Moteur - Pistons et Vilebrequin	Motor - Pistones y cigüeñal
Engine - Pistons And Crankshaft.....21013C03.1	Moteur - Pistons et Vilebrequin	Motor - Pistones y cigüeñal
Engine - Plug And Blank-Off Plug21010C24.1	Moteur - Bouchon et Obturateur	Motor - Tapón y obturador
Engine - Plug And Blank-Off Plug21011C24.1	Moteur - Bouchon et Obturateur	Motor - Tapón y obturador
Engine - Plug And Blank-Off Plug21012C24.1	Moteur - Bouchon et Obturateur	Motor - Tapón y obturador
Engine - Plug And Blank-Off Plug21013C24.1	Moteur - Bouchon et Obturateur	Motor - Tapón y obturador
Engine - Rockers21010C05.1	Moteur - Culbuteurs	Motor - Balancines de válvula
Engine - Rockers.....21011C05.1	Moteur - Culbuteurs	Motor - Balancines de válvula
Engine - Rockers.....21012C05.1	Moteur - Culbuteurs	Motor - Balancines de válvula
Engine - Rockers.....21013C05.1	Moteur - Culbuteurs	Motor - Balancines de válvula
Engine - Thermostat And Water Filter.....21010C10.1	Moteur - Thermostat et Filtre à Eau	Motor - Termostato y filtro de agua
Engine - Thermostat And Water Filter.....21011C10.1	Moteur - Thermostat et Filtre à Eau	Motor - Termostato y filtro de agua
Engine - Thermostat And Water Filter.....21012C10.1	Moteur - Thermostat et Filtre à Eau	Motor - Termostato y filtro de agua
Engine - Thermostat And Water Filter.....21013C10.1	Moteur - Thermostat et Filtre à Eau	Motor - Termostato y filtro de agua
Engine - Turbocharger Connections.....21010C08.1	Moteur - Raccords de Turbocompresseur	Motor - Racores de turbocompresor
Engine - Turbocharger Connections.....21011C08.1	Moteur - Raccords de Turbocompresseur	Motor - Racores de turbocompresor
Engine - Turbocharger Connections.....21012C08.1	Moteur - Raccords de Turbocompresseur	Motor - Racores de turbocompresor
Engine - Turbocharger Connections.....21013C08.1	Moteur - Raccords de Turbocompresseur	Motor - Racores de turbocompresor
Engine - Water Pump21010C11.1	Moteur - Pompe à Eau	Motor - Bomba de agua
Engine - Water Pump21011C11.1	Moteur - Pompe à Eau	Motor - Bomba de agua
Engine - Water Pump21012C11.1	Moteur - Pompe à Eau	Motor - Bomba de agua
Engine - Water Pump21013C11.1	Moteur - Pompe à Eau	Motor - Bomba de agua
Exhaust System.....23010C01.1	Échappement	Escape
Fuel System.....22004C01.1	Circuit de Carburant	Circuito combustible
Fuel System - Fuel Tank.....22004C02.1	Circuit de Carburant - Réservoir de Carburant	Circuito combustible - Depósito de combustible
Induction System - Air Filter24010C02.1	Induction - Filtre à Air	Sistema de inducción - Filtro aire



P - Engine and Ancillary Equipment • Moteur et auxiliaires • Motor y equipos auxiliares

Induction System - Air Filter	24011C02.1	Induction - Filtre à Air	Sistema de inducción - Filtro aire
Induction System - Air Filtration.....	24010C01.1	Induction - Filtration Air	Sistema de inducción - Filtración aire
Induction System - Air Filtration.....	24011C01.1	Induction - Filtration Air	Sistema de inducción - Filtración aire
Throttle Controls.....	42003C01.1	Accélérateur	Acelerador
Throttle Controls.....	42003C02.1	Accélérateur	Acelerador



Cooling System
Système de Refroidissement
Refrigeración

Rops
Rops
Rops

C-25010-01.1-A

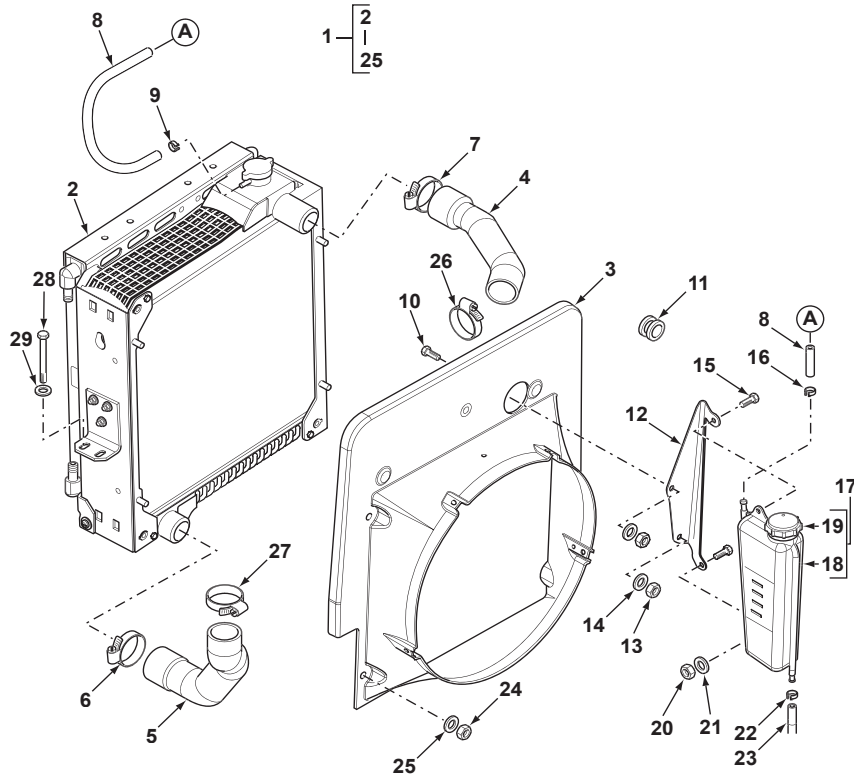

1	6110146M91			1	Radiator Assy	Ensemble de radiateur	Radiador, Conj.
2	6109204M91	1	25010C02.1 1	1	Radiator Assy	Ensemble de radiateur	Radiador, Conj.
3	6110011M1	1		1	Cowling	Capotage	Capotaje
4	6110104M1	1		1	Hose	Flexible	Tubo flexible
5	6109171M1	1		1	Hose	Flexible	Tubo flexible
6	3517415M1	1		1	Collar	Collier	Collar
7	3517415M1	1		1	Collar	Collier	Collar
8	6109001M1	1		1	Hose	Flexible	Tubo flexible
9	6100555M1	1		1	Clamp	Collier de serrage	Argolla de cierre
10	3009492X1	1	M10 x 25	1	Screw	Vis	Tornillo
11	3522133M2	1		1	Grommet	Passe-fil	Pasa cable
12	6108999M1	1		1	Bracket	Patte de fixation	Pata de fijación
13	1441932X1	1	M10	2	Nut	Écrou	Tuerca
14	390734X1	1	M10	2	Washer	Rondelle	Arandela
15	339123X1	1	M8 x 20	2	Bolt	Boulon	Perno
16	6100555M1	1		1	Clamp	Collier de serrage	Argolla de cierre
17	6109901M91	1		1	Tank, Expansion	Vase d'expansion	Vasija de expansión
18		17	Ref. 17	1	Reservoir	Réservoir	Depósito
19		17	Ref. 17	1	Cap	Chapeau	Sombbrero
20	1441461X1	1	M8	2	Nut	Écrou	Tuerca
21	390972X1	1	M8	2	Washer	Rondelle	Arandela
22	6100555M1	1		1	Clamp	Collier de serrage	Argolla de cierre
23	6109001M2	1		1	Hose	Flexible	Tubo flexible
24	1441932X1	1	M10	3	Nut	Écrou	Tuerca
25	390734X1	1	M10	3	Washer	Rondelle	Arandela
26	3517415M1			1	Collar	Collier	Collar
27	3517415M1			1	Collar	Collier	Collar
28	3009505X1		M12 x 25	4	Bolt	Boulon	Perno
29	385363X1		M12	4	Washer	Rondelle	Arandela



820 860 880
TX760B TX860B
TX870B

802 804 806 808 810 812 814 816 822 824 832 834 842 844 852 854

25010C01.1

6199042M3

1

Jan-06

Cooling System
Système de Refroidissement
Refrigeración

Without air conditioning
 Sans conditionneur
 Sin climatizador

C-25011-01.1-A

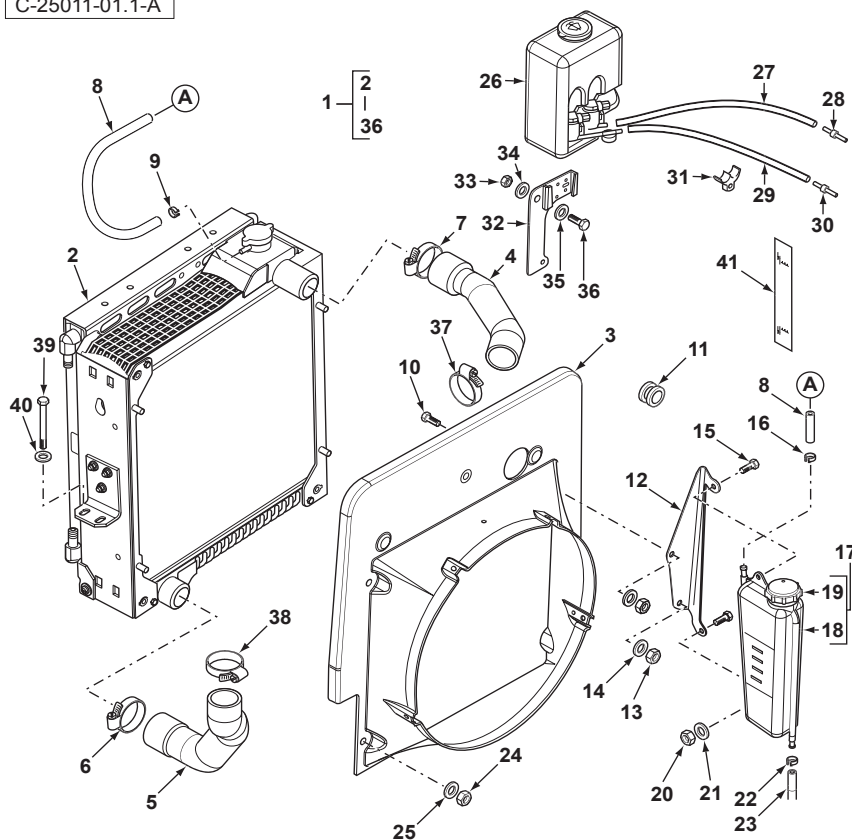

1	6110147M91			1	Radiator Assy	Ensemble de radiateur	Radiador, Conj.
2	6109204M91	1	25011C02.1 1	1	Radiator Assy	Ensemble de radiateur	Radiador, Conj.
3	6110011M1	1		1	Cowling	Capotage	Capotaje
4	6110104M1	1		1	Hose	Flexible	Tubo flexible
5	6109171M1	1		1	Hose	Flexible	Tubo flexible
6	3517415M1	1		1	Collar	Collier	Collar
7	3517415M1	1		1	Collar	Collier	Collar
8	6109001M1	1		1	Hose	Flexible	Tubo flexible
9	6100555M1	1		1	Clamp	Collier de serrage	Argolla de cierre
10	3009492X1	1	M10 x 25	1	Screw	Vis	Tornillo
11	3522133M2	1		1	Grommet	Passe-fil	Pasa cable
12	6108999M1	1		1	Bracket	Patte de fixation	Pata de fijación
13	1441932X1	1	M10	2	Nut	Écrou	Tuerca
14	390734X1	1	M10	2	Washer	Rondelle	Arandela
15	339123X1	1	M8 x 20	2	Bolt	Boulon	Perno
16	6100555M1	1		1	Clamp	Collier de serrage	Argolla de cierre
17	6109901M91	1		1	Tank, Expansion	Vase d'expansion	Vasija de expansión
18		17	Ref. 17	1	Reservoir	Réservoir	Depósito
19		17	Ref. 17	1	Cap	Chapeau	Sombbrero
20	1441461X1	1	M8	2	Nut	Écrou	Tuerca
21	390972X1	1	M8	2	Washer	Rondelle	Arandela
22	6100555M1	1		1	Clamp	Collier de serrage	Argolla de cierre
23	6109001M2	1		1	Hose	Flexible	Tubo flexible
24	1441932X1	1	M10	3	Nut	Écrou	Tuerca
25	390734X1	1	M10	3	Washer	Rondelle	Arandela
26	6109829M91	1	Windscreen Washer	1	Reservoir Assy	Ensemble de réservoir	Depósito, Conj.
27	3516102M1	1		1	Tube	Tube	Tubo
28	3516103M1	1		1	Connector	Connecteur	Conector
29	3516102M1	1		1	Tube	Tube	Tubo
30	3516103M1	1		1	Connector	Connecteur	Conector
31	3520363M1	1		2	Clip	Clip	Clip
32	6110310M91	1		1	Mount	Support de fixation	Soporte de fijación
33	1441932X1	1	M10	1	Nut	Écrou	Tuerca
34	390734X1	1	M10	1	Washer	Rondelle	Arandela
35	390734X1	1	M10	1	Washer	Rondelle	Arandela
36	3009492X1	1	M10 x 25	1	Screw	Vis	Tornillo
37	3517415M1			1	Collar	Collier	Collar
38	3517415M1			1	Collar	Collier	Collar
39	3009505X1		M12 x 25	4	Bolt	Boulon	Perno
40	385363X1		M12	4	Washer	Rondelle	Arandela
41	6100661M1			1	Decal	Adhésif	Adhesivo



820 860 880 970 980
 TX760B TX860B
 TX870B TX970B

801 803 805 807 809 811 813 815 817 821 823 825 831 833 841 843 845 851 853
 855 921 922 923 931 932

25011C01.1

6199042M3

1

Jan-06

Cooling System
Système de Refroidissement
Refrigeración

With air conditioning
 Avec conditionneur
 Con climatizador

C-25012-01.1-A

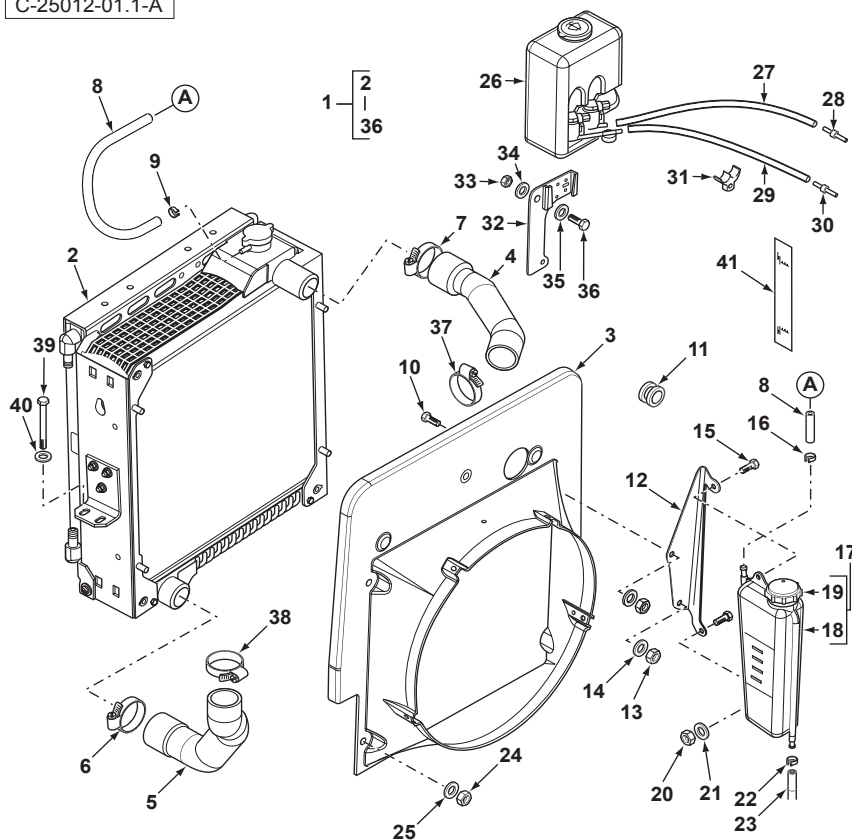

1	6110148M91		1	Radiator Assy	Ensemble de radiateur	Radiador, Conj.
2	6108984M91	1	25012C02.1 1	Radiator Assy	Ensemble de radiateur	Radiador, Conj.
3	6110011M1	1		Cowling	Capotage	Capotaje
4	6110104M1	1		Hose	Flexible	Tubo flexible
5	6109171M1	1		Hose	Flexible	Tubo flexible
6	3517415M1	1		Collar	Collier	Collar
7	3517415M1	1		Collar	Collier	Collar
8	6109001M1	1		Hose	Flexible	Tubo flexible
9	6100555M1	1		Clamp	Collier de serrage	Argolla de cierre
10	3009492X1	1	M10 x 25	Screw	Vis	Tornillo
11	3522133M2	1		Grommet	Passe-fil	Pasa cable
12	6108999M1	1		Bracket	Patte de fixation	Pata de fijación
13	1441932X1	1	M10	Nut	Écrou	Tuerca
14	390734X1	1	M10	Washer	Rondelle	Arandela
15	339123X1	1	M8 x 20	Bolt	Boulon	Perno
16	6100555M1	1		Clamp	Collier de serrage	Argolla de cierre
17	6109901M91	1		Tank, Expansion	Vase d'expansion	Vasija de expansión
18		17	Ref. 17	Reservoir	Réservoir	Depósito
19		17	Ref. 17	Cap	Chapeau	Sombbrero
20	1441461X1	1	M8	Nut	Écrou	Tuerca
21	390972X1	1	M8	Washer	Rondelle	Arandela
22	6100555M1	1		Clamp	Collier de serrage	Argolla de cierre
23	6109001M2	1		Hose	Flexible	Tubo flexible
24	1441932X1	1	M10	Nut	Écrou	Tuerca
25	390734X1	1	M10	Washer	Rondelle	Arandela
26	6109829M91	1	Windscreen Washer	Reservoir Assy	Ensemble de réservoir	Depósito, Conj.
27	3516102M1	1		Tube	Tube	Tubo
28	3516103M1	1		Connector	Connecteur	Conector
29	3516102M1	1		Tube	Tube	Tubo
30	3516103M1	1		Connector	Connecteur	Conector
31	3520363M1	1		Clip	Clip	Clip
32	6110310M91	1		Mount	Support de fixation	Soporte de fijación
33	1441932X1	1	M10	Nut	Écrou	Tuerca
34	390734X1	1	M10	Washer	Rondelle	Arandela
35	390734X1	1	M10	Washer	Rondelle	Arandela
36	3009492X1	1	M10 x 25	Screw	Vis	Tornillo
37	3517415M1	1		Collar	Collier	Collar
38	3517415M1	1		Collar	Collier	Collar
39	3009505X1		M12 x 25	Bolt	Boulon	Perno
40	385363X1		M12	Washer	Rondelle	Arandela
41	6100661M1			Decal	Adhésif	Adhesivo



820 860 880 970 980
 TX760B TX860B
 TX870B TX970B

801 803 805 807 809 811 813 815 817 821 823 825 831 833 841 843 845 851 853
 855 921 922 923 931 932

25012C01.1

6199042M3

1

Jan-06

Cooling System
Système de Refroidissement
Refrigeración

Radiator Assembly
Montage de Radiateur
Conjunto de radiador

Rops
Rops
Rops

C-25010-02.1-A

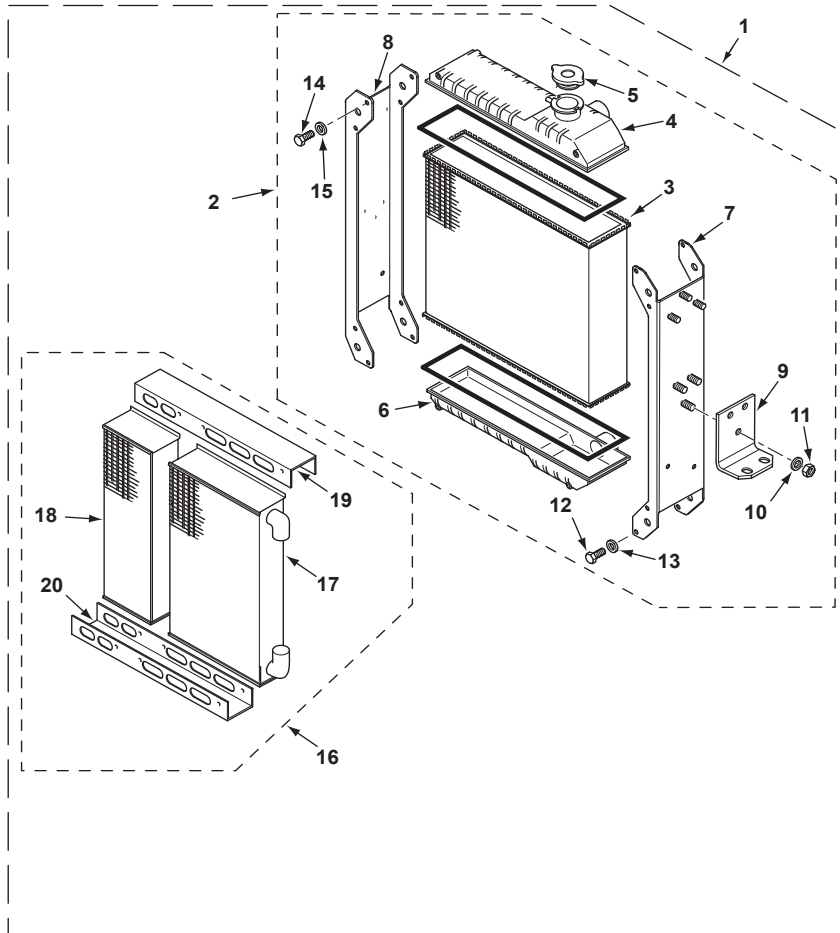

1	6109204M91	25010C01.1 2	1	Radiator Assy	Ensemble de radiateur	Radiador, Conj.
2	6108985M91		1	Radiator	Radiateur	Radiador
3		Ref. 2	1	Element	Élément	Elemento
4		Ref. 2	1	Cover	Cache	Tapa
5	6190650M1		1	Cap, Filler	Bouchon rempliss.	Tapón de llenado
6		Ref. 2	1	Cover	Cache	Tapa
7	6194151M91		1	Support Assy	Ensemble de support	Apoyadero, Conj.
8	6194152M91		1	Support Assy	Ensemble de support	Apoyadero, Conj.
9	6194153M1		2	Bracket	Patte de fixation	Pata de fijación
10	6190793M1	M10	6	Washer	Rondelle	Arandela
11	6190792M1	M10	6	Nut, Lock	Écrou de blocage	Tuerca de retención
12	6190790M1	M8 x 12	4	Screw	Vis	Tornillo
13	6190791M1	M8	4	Washer	Rondelle	Arandela
14	6190790M1	M8 x 12	4	Screw	Vis	Tornillo
15	6190791M1	M8	4	Washer	Rondelle	Arandela
16	6109684M91		1	Cooler Assy, Oil	Ensemble huile refr.	Aceite conjunto enfr.
17		Ref. 16	1	Element	Élément	Elemento
18		Ref. 16	1	Element	Élément	Elemento
19	6194155M1		1	Support	Support	Soporte
20	6194154M1		1	Support	Support	Soporte



820 860 880
TX760B TX860B
TX870B

802 804 806 808 810 812 814 816 822 824 832 834 842 844 852 854

25010C02.1

6199042M3

1

Jan-06

Cooling System
Système de Refroidissement
Refrigeración

Radiator Assembly
Montage de Radiateur
Conjunto de radiador

Without air conditioning
 Sans conditionneur
 Sin climatizador

C-25011-02.1-A

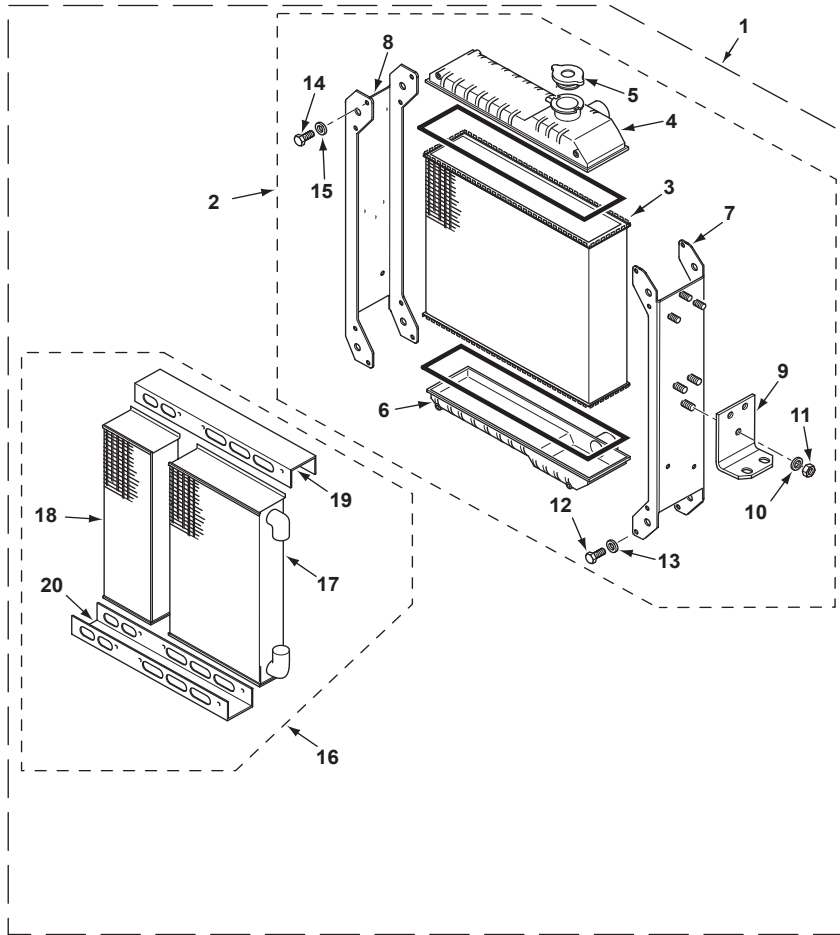

1	6109204M91		☉ 25011C01.1 2	1	Radiator Assy	Ensemble de radiateur	Radiador, Conj.
2	6108985M91	1		1	Radiator	Radiateur	Radiador
3		2	▬ Ref. 2	1	Element	Élément	Elemento
4		2	▬ Ref. 2	1	Cover	Cache	Tapa
5	6190650M1	2		1	Cap, Filler	Bouchon rempliss.	Tapón de llenado
6		2	▬ Ref. 2	1	Cover	Cache	Tapa
7	6194151M91	2	◀	1	Support Assy	Ensemble de support	Apoyadero, Conj.
8	6194152M91	2	▶	1	Support Assy	Ensemble de support	Apoyadero, Conj.
9	6194153M1	2		2	Bracket	Patte de fixation	Pata de fijación
10	6190793M1	2	M10	6	Washer	Rondelle	Arandela
11	6190792M1	2	M10	6	Nut, Lock	Écrou de blocage	Tuerca de retención
12	6190790M1	2	M8 x 12	4	Screw	Vis	Tornillo
13	6190791M1	2	M8	4	Washer	Rondelle	Arandela
14	6190790M1	2	M8 x 12	4	Screw	Vis	Tornillo
15	6190791M1	2	M8	4	Washer	Rondelle	Arandela
16	6109684M91	1		1	Cooler Assy, Oil	Ensemble huile refr.	Aceite conjunto enfr.
17		16	▬ Ref. 16	1	Element	Élément	Elemento
18		16	▬ Ref. 16	1	Element	Élément	Elemento
19	6194155M1	16	▲	1	Support	Support	Soporte
20	6194154M1	16	▼	1	Support	Support	Soporte



820 860 880 970 980
 TX760B TX860B
 TX870B TX970B

801 803 805 807 809 811 813 815 817 821 823 825 831 833 841 843 845 851 853
 855 921 922 923 931 932

25011C02.1

6199042M3

1

Jan-06

Cooling System
Système de Refroidissement
Refrigeración

Radiator Assembly
Montage de Radiateur
Conjunto de radiador

With air conditioning
 Avec conditionneur
 Con climatizador

C-25012-02.1-A

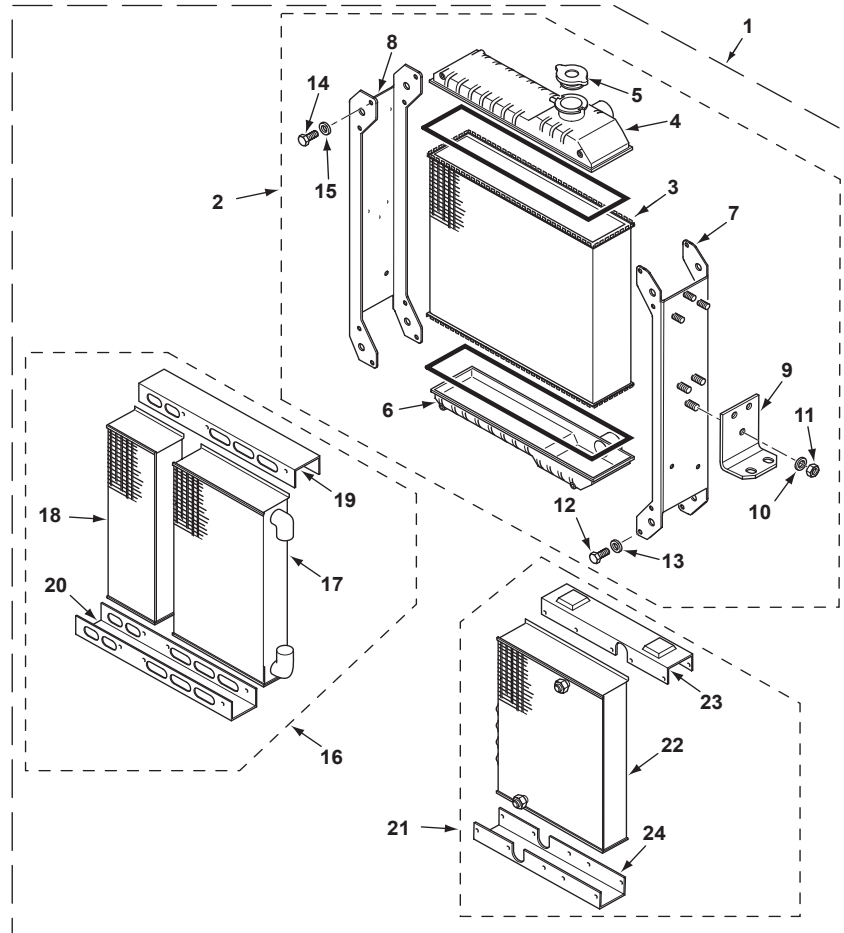

1	6108984M91	1	☉ 25012C01.1 2	1	Radiator Assy	Ensemble de radiateur	Radiador, Conj.
2	6108985M91	1		1	Radiator	Radiateur	Radiador
3		2	▬ Ref. 2	1	Element	Élément	Elemento
4		2	▬ Ref. 2	1	Cover	Cache	Tapa
5	6190650M1	2		1	Cap, Filler	Bouchon rempliss.	Tapón de llenado
6		2	▬ Ref. 2	1	Cover	Cache	Tapa
7	6194151M91	2	◀	1	Support Assy	Ensemble de support	Apoyadero, Conj.
8	6194152M91	2	▶	1	Support Assy	Ensemble de support	Apoyadero, Conj.
9	6194153M1	2		2	Bracket	Patte de fixation	Pata de fijación
10	6190793M1	2	M10	6	Washer	Rondelle	Arandela
11	6190792M1	2	M10	6	Nut, Lock	Écrou de blocage	Tuerca de retención
12	6190790M1	2	M8 x 12	4	Screw	Vis	Tornillo
13	6190791M1	2	M8	4	Washer	Rondelle	Arandela
14	6190790M1	2	M8 x 12	4	Screw	Vis	Tornillo
15	6190791M1	2	M8	4	Washer	Rondelle	Arandela
16	6109684M91	1		1	Cooler Assy, Oil	Ensemble huile refr.	Aceite conjunto enfr.
17		16	▬ Ref. 16	1	Element	Élément	Elemento
18		16	▬ Ref. 16	1	Element	Élément	Elemento
19	6194155M1	16	▲	1	Support	Support	Soporte
20	6194154M1	16	▼	1	Support	Support	Soporte
21	6193306M91	1		1	Condenser	Condensateur	Condensador
22		21	▬ Ref. 21	1	Element	Élément	Elemento
23	6193307M91	21		1	Support Assy	Ensemble de support	Apoyadero, Conj.
24	6193307M91	21		1	Support Assy	Ensemble de support	Apoyadero, Conj.



820 860 880 970 980
 TX760B TX860B
 TX870B TX970B

801 803 805 807 809 811 813 815 817 821 823 825 831 833 841 843 845 851 853
 855 921 922 923 931 932

25012C02.1

6199042M3

1

Jan-06

Engine
Moteur
Motor

Alternator And Mounting
Fixation de L'alternateur
Fijación alternador

RG38100
RG38100
RG38100

C-21010-21.1-A

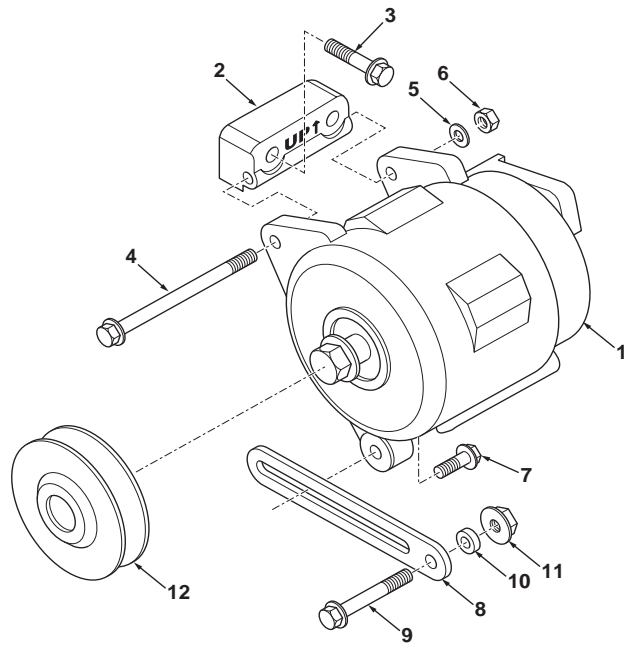

1	2871A302	(A)	1	Alternator Assy	Ensemble d'alternateur	Alternador, Conj.
2	3824A071		1	Bracket	Patte de fixation	Pata de fijación
3	2314J007		2	Screw	Vis	Tornillo
4	2314H052		1	Screw	Vis	Tornillo
5	2131A008		1	Washer	Rondelle	Arandela
6	2318D208		1	Nut	Écrou	Tuerca
7	2314H103		1	Screw	Vis	Tornillo
8	36155429		1	Rod, Adjusting	Tringle de réglage	Tirante de ajuste
9	2314J012		1	Screw	Vis	Tornillo
10	0920465		1	Spacer	Entretoise	Traviesa
11	2318A604		1	Nut	Écrou	Tuerca
12	3113E031		1	Pulley	Poulie	Polea

A Details to be advised
Détails à demander
Detalles que deben ser notificados



820
TX760B

801 802 803 804 805 806 807 808 831 832 833 834

21010C21.1

6199042M3

1

Jan-06

Engine
Moteur
Motor

Alternator And Mounting
Fixation de L'alternateur
Fijación alternador

RG38043
RG38043
RG38043

C-21011-21.1-A

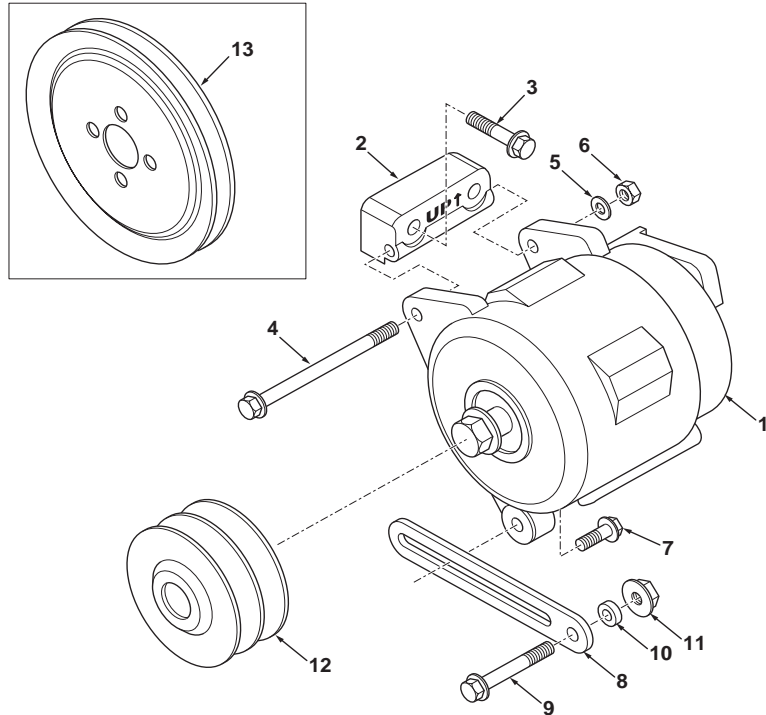

1	2871A304	(A)	1	Alternator Assy	Ensemble d'alternateur	Alternador, Conj.
2	3824A071		1	Bracket	Patte de fixation	Pata de fijación
3	2314J007		2	Screw	Vis	Tornillo
4	2314H022	M8 x 130	1	Screw	Vis	Tornillo
5	2131A008		1	Washer	Rondelle	Arandela
6	2318D208		1	Nut	Écrou	Tuerca
7	2314H103		1	Screw	Vis	Tornillo
8	36155429		1	Rod, Adjusting	Tringle de réglage	Tirante de ajuste
9	2314J012		1	Screw	Vis	Tornillo
10	0920465		1	Spacer	Entretoise	Traviesa
11	2318A604		1	Nut	Écrou	Tuerca
12	3115A121		1	Pulley	Poulie	Polea
13	3114X191		1	Pulley	Poulie	Polea

A Details to be advised
Détails à demander
Detalles que deben ser notificados



820
TX760B

801 803 805 807 831 833

21011C21.1

6199042M3

1

Jan-06

Engine
Moteur
Motor

Alternator And Mounting
Fixation de L'alternateur
Fijación alternador

RG38099
RG38099
RG38099

C-21012-21.1-A

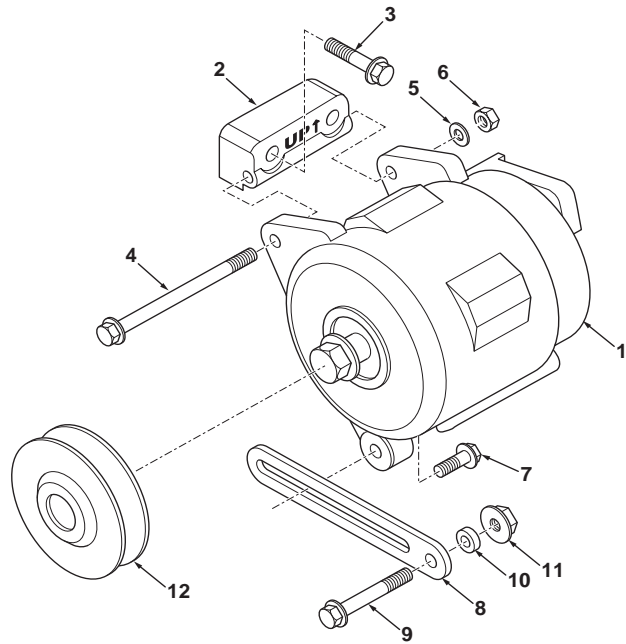

1	2871A302	(A)	1	Alternator Assy	Ensemble d'alternateur	Alternador, Conj.
2	3824A071		1	Bracket	Patte de fixation	Pata de fijación
3	2314J007		2	Screw	Vis	Tornillo
4	2314H052		1	Screw	Vis	Tornillo
5	2131A008		1	Washer	Rondelle	Arandela
6	2318D208		1	Nut	Écrou	Tuerca
7	2314H103		1	Screw	Vis	Tornillo
8	36155429		1	Rod, Adjusting	Tringle de réglage	Tirante de ajuste
9	2314J012		1	Screw	Vis	Tornillo
10	0920465		1	Spacer	Entretoise	Traviesa
11	2318A604		1	Nut	Écrou	Tuerca
12	3113E031		1	Pulley	Poulie	Polea

A Details to be advised
Détails à demander
Detalles que deben ser notificados



860 880 970 980
TX860B TX870B
TX970B

809 810 811 812 813 814 815 816 817 821 822 823 824 825 841 842 843 844 845
851 852 853 854 855 921 922 923 931 932

21012C21.1

6199042M3

1

Jan-06

Engine
Moteur
Motor

Alternator And Mounting
Fixation de L'alternateur
Fijación alternador

RG38044
RG38044
RG38044

C-21013-21.1-A

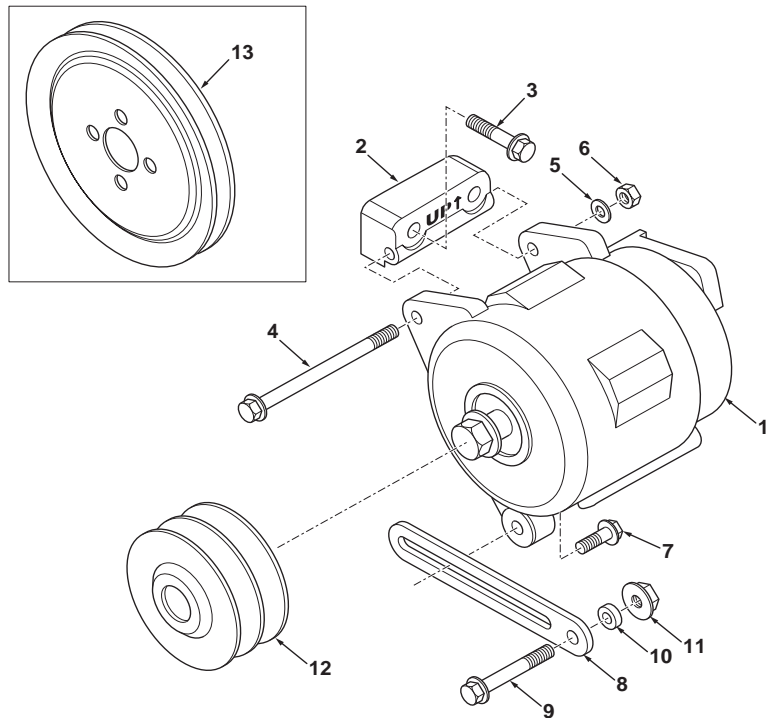

1	2871A304	(A)	1	Alternator Assy	Ensemble d'alternateur	Alternador, Conj.
2	3824A071		1	Bracket	Patte de fixation	Pata de fijación
3	2314J007		2	Screw	Vis	Tornillo
4	2314H022	M8 x 130	1	Screw	Vis	Tornillo
5	2131A008		1	Washer	Rondelle	Arandela
6	2318D208		1	Nut	Écrou	Tuerca
7	2314H103		1	Screw	Vis	Tornillo
8	36155429		1	Rod, Adjusting	Tringle de réglage	Tirante de ajuste
9	2314J012		1	Screw	Vis	Tornillo
10	0920465		1	Spacer	Entretoise	Traviesa
11	2318A604		1	Nut	Écrou	Tuerca
12	3115A121		1	Pulley	Poulie	Polea
13	3114X191		1	Pulley	Poulie	Polea

A Details to be advised
Détails à demander
Detalles que deben ser notificados



860 880 970 980
TX860B TX870B
TX970B

809 811 813 815 817 821 823 825 841 843 845 851 853 855 921 922 923 931 932

21013C21.1

6199042M3

1

Jan-06

Engine
Moteur
Motor

Camshaft
Arbre à Cames
Árbol de levas

RG38100
RG38100
RG38100

C-21010-06.1-A

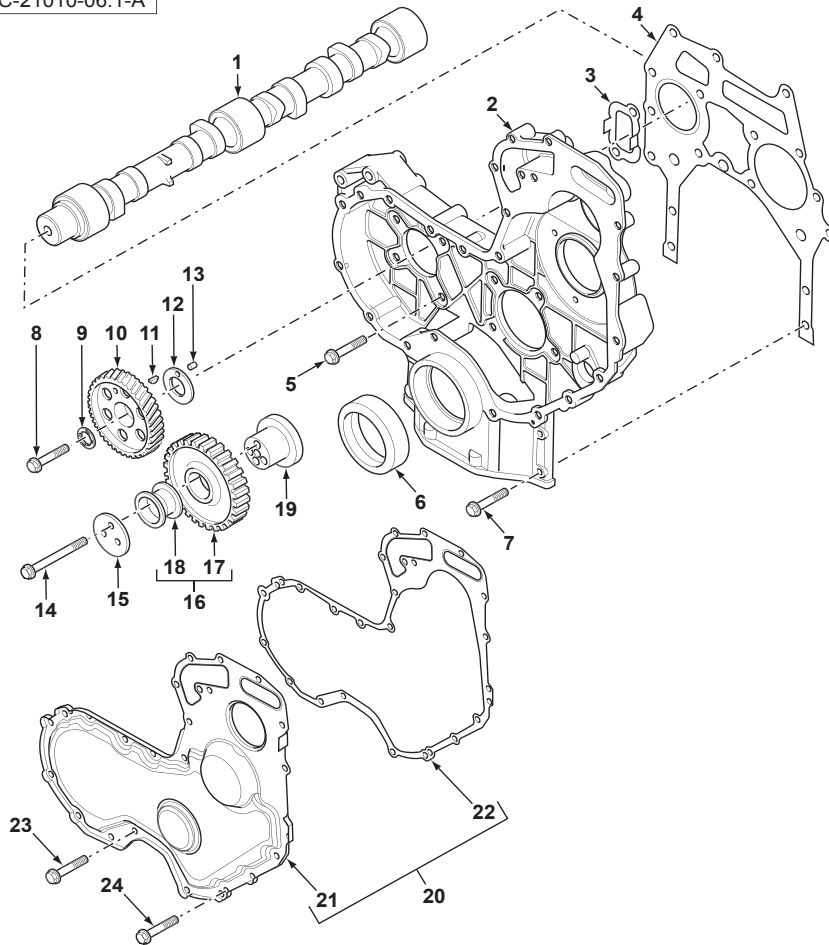

1	3141D222			1	Camshaft	Arbre à cames	Árbol de levas
2	3716C461			1	Housing	Carter	Cárter
3	3617V016			1	Joint	Articulation	Articulación
4	3617V015			1	Joint	Articulation	Articulación
5	2314H003	M8 x 20		8	Screw	Vis	Tornillo
6	2418F436			1	Ring, Sealing	Bague d'étanchéité	Anillo, Estanqueidad
7	2314H034	M8 x 25		4	Screw	Vis	Tornillo
8	2314J606	M12 x 45		1	Screw	Vis	Tornillo
9	3112X011			1	Washer, Thrust	Rondelle de butée	Arandela de tope
10	3117N001			1	Gear	Pignon	Piñón
11	0500012			1	Key, Woodruff	Clavette demi-lune	Chaveta media-luna
12	3321A003			1	Washer	Rondelle	Arandela
13	2116053			1	Pin, Dowel	Goupille position.	Peón
14	2314J010	M10 x 60		3	Screw	Vis	Tornillo
15	3241H009			1	Plate	Plaque	Placa
16	3117N042			1	Gear Assy	Ensemble d'engrenage	Engranaje, Conj.
17		16	➡ Ref. 16	1	Gear	Pignon	Piñón
18	0050345	16		2	Ring, Set	Jeu de bagues	Juego de anillos
19	33426161			1	Hub	Moyeu	Cubo
20	4142A501			1	Cover Assy	Ensemble de couvercle	Tapa, Conj.
21		20	➡ Ref. 20	1	Cover	Cache	Tapa
22	3681P046	20		1	Joint	Articulation	Articulación
23	2314H002	M8 x 16		10	Screw	Vis	Tornillo
24	2314H012			5	Screw	Vis	Tornillo



820
TX760B

801 802 803 804 805 806 807 808 831 832 833 834

21010C06.1

6199042M3

1

Jan-06

Engine
Moteur
Motor

Camshaft
Arbre à Cames
Árbol de levas

RG38043
RG38043
RG38043

C-21011-06.1-A

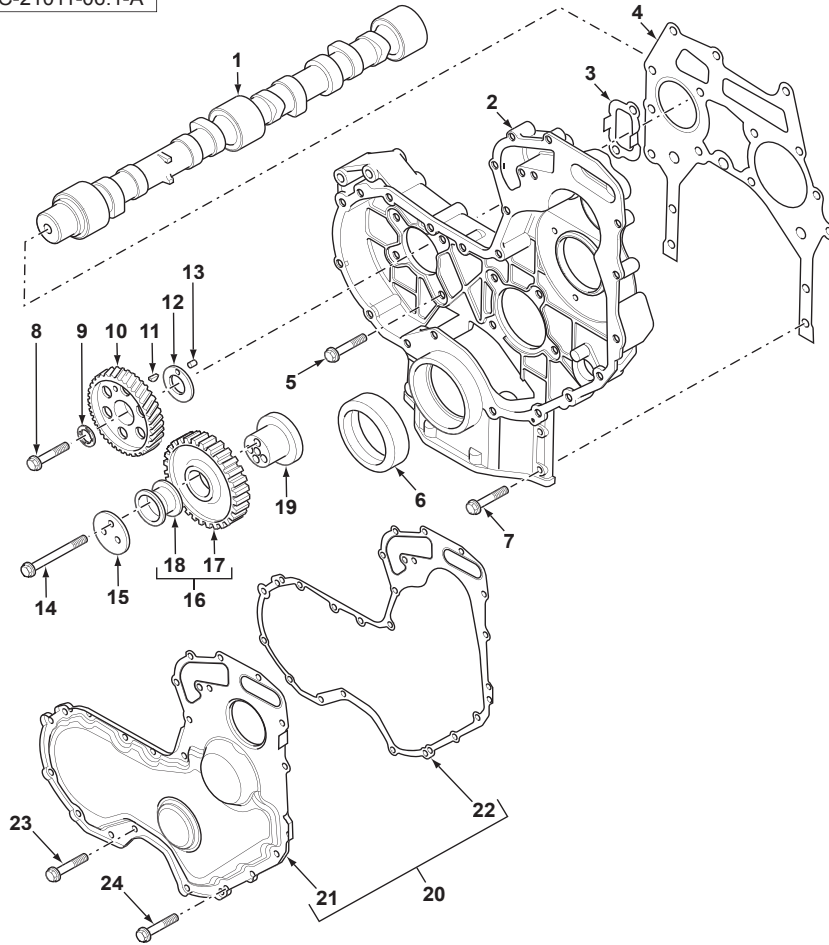

1	3141D222			1	Camshaft	Arbre à cames	Árbol de levas
2	3716C461			1	Housing	Carter	Cárter
3	3617V016			1	Joint	Articulation	Articulación
4	3617V015			1	Joint	Articulation	Articulación
5	2314H003	M8 x 20		8	Screw	Vis	Tornillo
6	2418F436			1	Ring, Sealing	Bague d'étanchéité	Anillo, Estanqueidad
7	2314H034	M8 x 25		4	Screw	Vis	Tornillo
8	2314J606	M12 x 45		1	Screw	Vis	Tornillo
9	3112X011			1	Washer, Thrust	Rondelle de butée	Arandela de tope
10	3117N001			1	Gear	Pignon	Piñón
11	0500012			1	Key, Woodruff	Clavette demi-lune	Chaveta media-luna
12	3321A003			1	Washer	Rondelle	Arandela
13	2116053			1	Pin, Dowel	Goupille position.	Peón
14	2314J010	M10 x 60		3	Screw	Vis	Tornillo
15	3241H009			1	Plate	Plaque	Placa
16	3117N042			1	Gear Assy	Ensemble d'engrenage	Engranaje, Conj.
17		16	➡ Ref. 16	1	Gear	Pignon	Piñón
18	0050345	16		2	Ring, Set	Jeu de bagues	Juego de anillos
19	33426161			1	Hub	Moyeu	Cubo
20	4142A501			1	Cover Assy	Ensemble de couvercle	Tapa, Conj.
21		20	➡ Ref. 20	1	Cover	Cache	Tapa
22	3681P046	20		1	Joint	Articulation	Articulación
23	2314H002	M8 x 16		10	Screw	Vis	Tornillo
24	2314H012			5	Screw	Vis	Tornillo



820
TX760B

801 803 805 807 831 833

21011C06.1

6199042M3

1

Jan-06

Engine
Moteur
Motor

Camshaft
Arbre à Cames
Árbol de levas

RG38099
RG38099
RG38099

C-21012-06.1-A

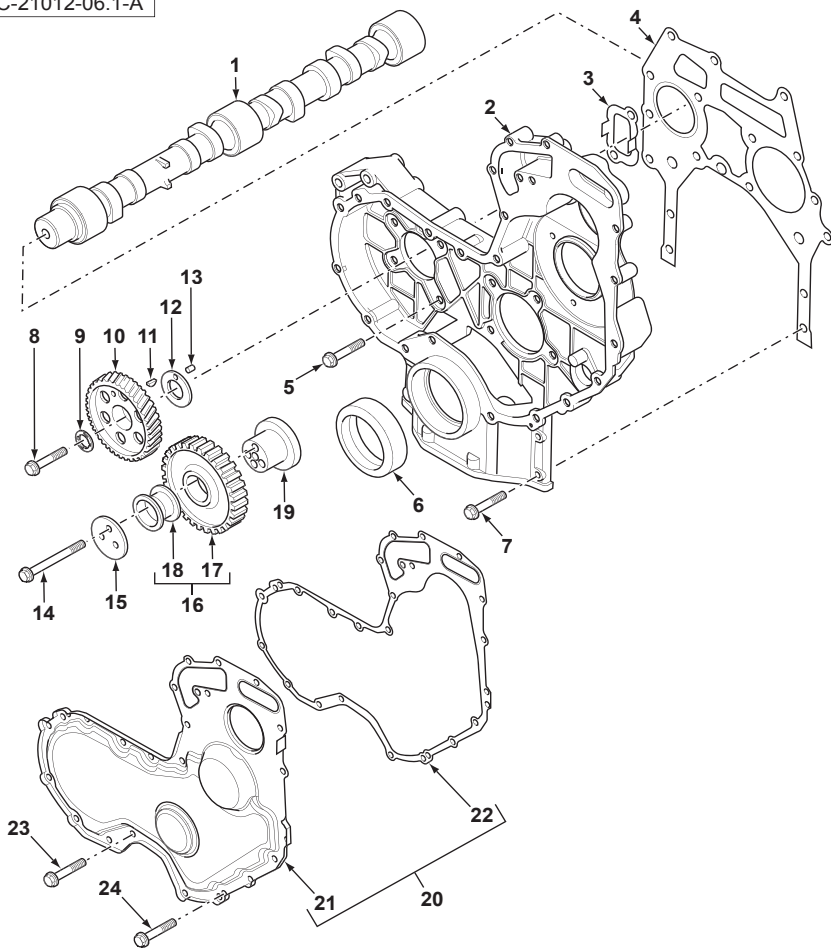

1	3141D222			1	Camshaft	Arbre à cames	Árbol de levas
2	3716C461			1	Housing	Carter	Cárter
3	3617V016			1	Joint	Articulation	Articulación
4	3617V015			1	Joint	Articulation	Articulación
5	2314H003	M8 x 20		8	Screw	Vis	Tornillo
6	2418F436			1	Ring, Sealing	Bague d'étanchéité	Anillo, Estanqueidad
7	2314H034	M8 x 25		4	Screw	Vis	Tornillo
8	2314J606	M12 x 45		1	Screw	Vis	Tornillo
9	3112X011			1	Washer, Thrust	Rondelle de butée	Arandela de tope
10	3117N001			1	Gear	Pignon	Piñón
11	0500012			1	Key, Woodruff	Clavette demi-lune	Chaveta media-luna
12	3321A003			1	Washer	Rondelle	Arandela
13	2116053			1	Pin, Dowel	Goupille position.	Peón
14	2314J010	M10 x 60		3	Screw	Vis	Tornillo
15	3241H009			1	Plate	Plaque	Placa
16	3117N042			1	Gear Assy	Ensemble d'engrenage	Engranaje, Conj.
17		16	➡ Ref. 16	1	Gear	Pignon	Piñón
18	0050345	16		2	Ring, Set	Jeu de bagues	Juego de anillos
19	33426161			1	Hub	Moyeu	Cubo
20	4142A501			1	Cover Assy	Ensemble de couvercle	Tapa, Conj.
21		20	➡ Ref. 20	1	Cover	Cache	Tapa
22	3681P046	20		1	Joint	Articulation	Articulación
23	2314H002	M8 x 16		10	Screw	Vis	Tornillo
24	2314H012			5	Screw	Vis	Tornillo



860 880 970 980
TX860B TX870B
TX970B

809 810 811 812 813 814 815 816 817 821 822 823 824 825 841 842 843 844 845
851 852 853 854 855 921 922 923 931 932

21012C06.1

6199042M3

1

Jan-06

Engine
Moteur
Motor

Camshaft
Arbre à Cames
Árbol de levas

RG38044
RG38044
RG38044

C-21013-06.1-A

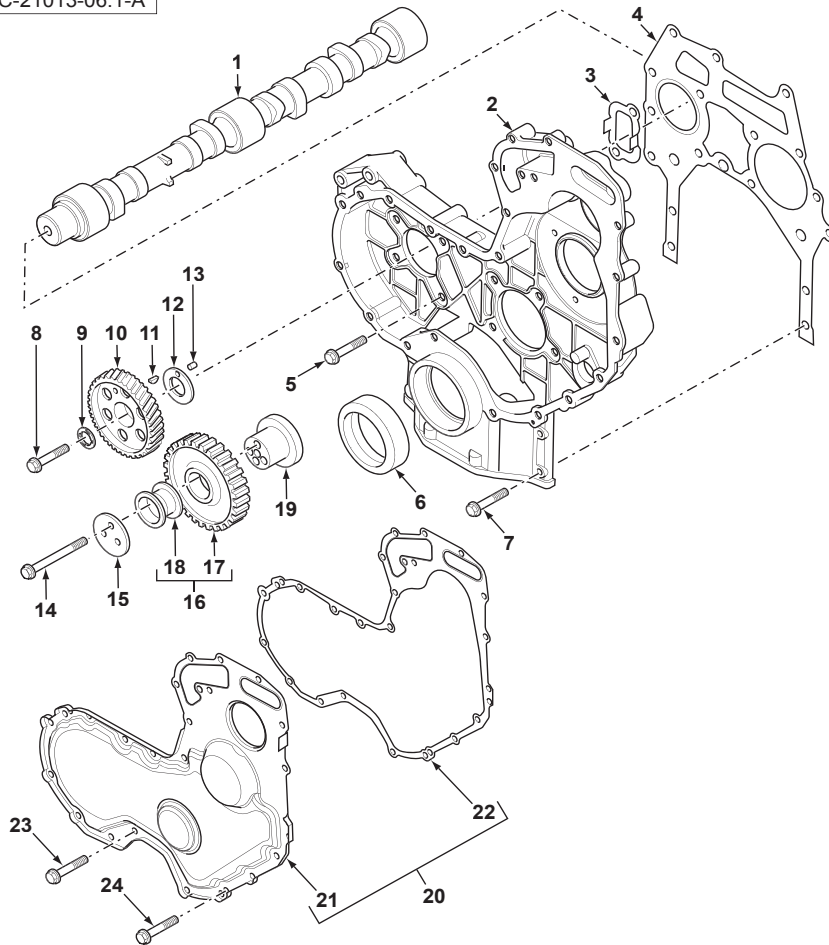

1	3141D222			1	Camshaft	Arbre à cames	Árbol de levas
2	3716C461			1	Housing	Carter	Cárter
3	3617V016			1	Joint	Articulation	Articulación
4	3617V015			1	Joint	Articulation	Articulación
5	2314H003	M8 x 20		8	Screw	Vis	Tornillo
6	2418F436			1	Ring, Sealing	Bague d'étanchéité	Anillo, Estanqueidad
7	2314H034	M8 x 25		4	Screw	Vis	Tornillo
8	2314J606	M12 x 45		1	Screw	Vis	Tornillo
9	3112X011			1	Washer, Thrust	Rondelle de butée	Arandela de tope
10	3117N001			1	Gear	Pignon	Piñón
11	0500012			1	Key, Woodruff	Clavette demi-lune	Chaveta media-luna
12	3321A003			1	Washer	Rondelle	Arandela
13	2116053			1	Pin, Dowel	Goupille position.	Peón
14	2314J010	M10 x 60		3	Screw	Vis	Tornillo
15	3241H009			1	Plate	Plaque	Placa
16	3117N042			1	Gear Assy	Ensemble d'engrenage	Engranaje, Conj.
17		16	➡ Ref. 16	1	Gear	Pignon	Piñón
18	0050345	16		2	Ring, Set	Jeu de bagues	Juego de anillos
19	33426161			1	Hub	Moyeu	Cubo
20	4142A501			1	Cover Assy	Ensemble de couvercle	Tapa, Conj.
21		20	➡ Ref. 20	1	Cover	Cache	Tapa
22	3681P046	20		1	Joint	Articulation	Articulación
23	2314H002	M8 x 16		10	Screw	Vis	Tornillo
24	2314H012			5	Screw	Vis	Tornillo



860 880 970 980
TX860B TX870B
TX970B

809 811 813 815 817 821 823 825 841 843 845 851 853 855 921 922 923 931 932

21013C06.1

6199042M3

1

Jan-06

Engine
Moteur
Motor

Crankshaft Pulley
Poulie de vilebrequin
Polea de cigüeñal

RG38100
RG38100
RG38100

C-21010-12.1-A

1	3114P061			1	Pulley	Poulie	Polea
2	3241N001			1	Stop	Butée	Tope
3	32186137			3	Bolt	Boulon	Perno

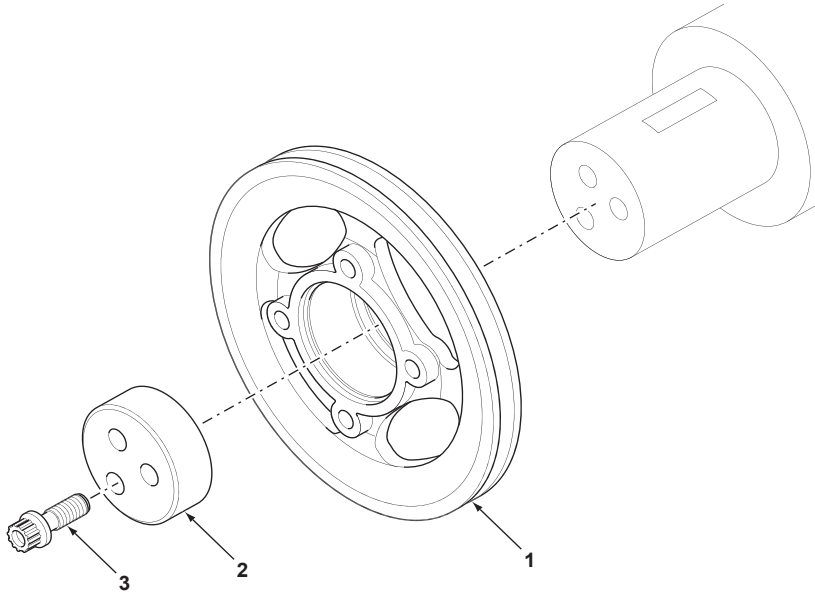

820
TX760B

801 802 803 804 805 806 807 808 831 832 833 834

21010C12.1

6199042M3

1

Jan-06

Engine
Moteur
Motor

Crankshaft Pulley
Poulie de Vilebrequin
Polea de cigüeñal

RG38043
RG38043
RG38043

C-21011-12.1-A

1	3115T081			1	Pulley	Poulie	Polea
2	3241N001			1	Stop	Butée	Tope
3	32186137			3	Bolt	Boulon	Perno

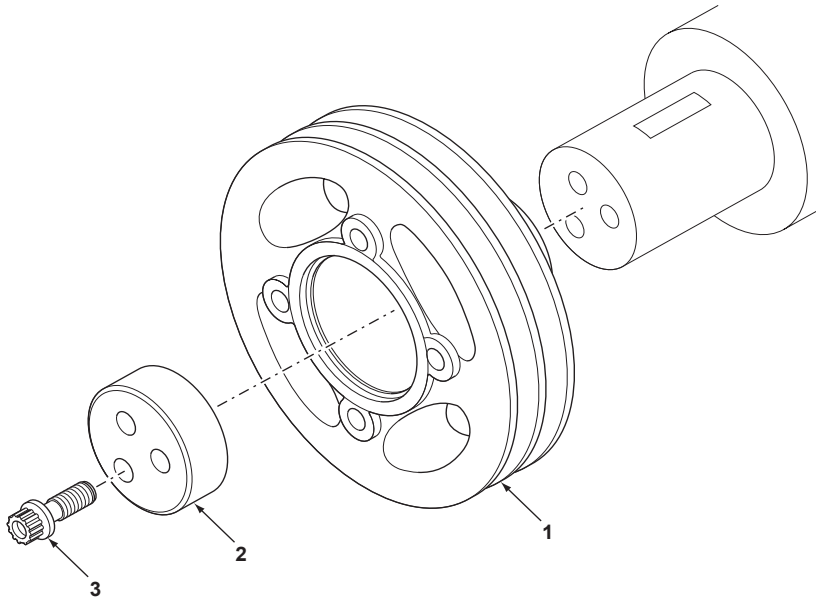

820
TX760B

801 803 805 807 831 833

21011C12.1

6199042M3

1

Jan-06

Engine
Moteur
Motor

Crankshaft Pulley
Poulie de Vilebrequin
Polea de cigüeñal

RG38099
RG38099
RG38099

C-21012-12.1-A

1	3114P061			1	Pulley	Poulie	Polea
2	3241N001			1	Stop	Butée	Tope
3	32186137			3	Bolt	Boulon	Perno

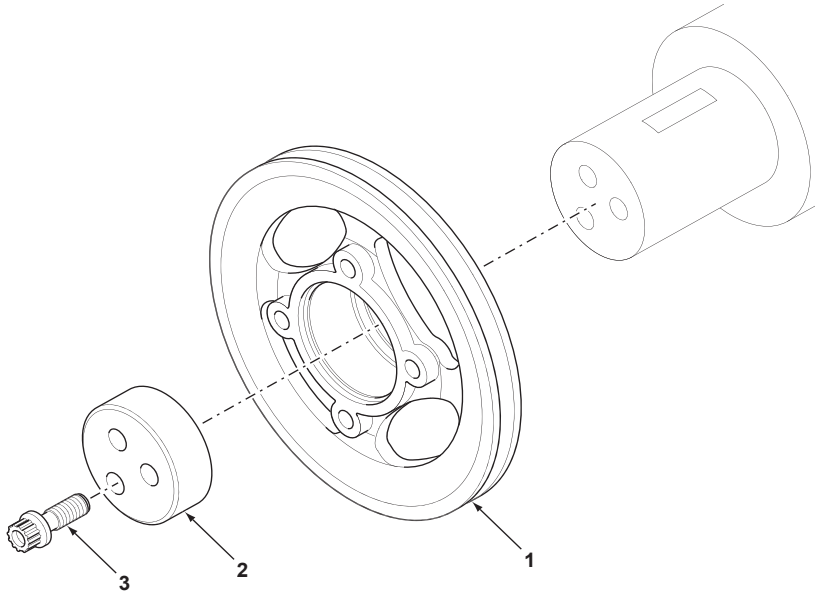

860 880 970 980
TX860B TX870B
TX970B

809 810 811 812 813 814 815 816 817 821 822 823 824 825 841 842 843 844 845
851 852 853 854 855 921 922 923 931 932

21012C12.1

6199042M3

1

Jan-06

Engine
Moteur
Motor

Crankshaft Pulley
Poulie de Vilebrequin
Polea de cigüeñal

RG38044
RG38044
RG38044

C-21013-12.1-A

1	3115T081			1	Pulley	Poulie	Polea
2	3241N001			1	Stop	Butée	Tope
3	32186137			3	Bolt	Boulon	Perno

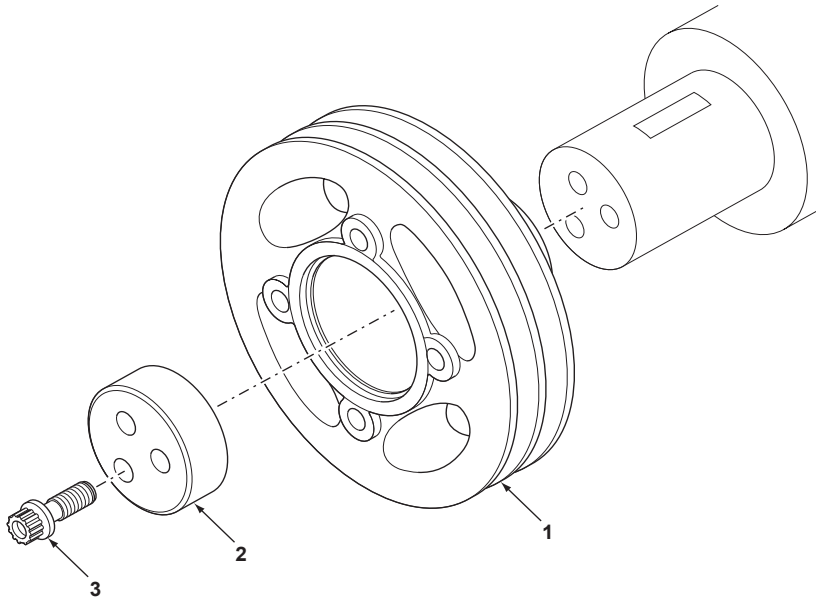

860 880 970 980
TX860B TX870B
TX970B

809 811 813 815 817 821 823 825 841 843 845 851 853 855 921 922 923 931 932

21013C12.1

6199042M3

1

Jan-06

Engine
 Moteur
 Motor

Cylinder Block
 Bloc Cylindres
 Bloque cilindros

RG38100
 RG38100
 RG38100

C-21010-02.1-A

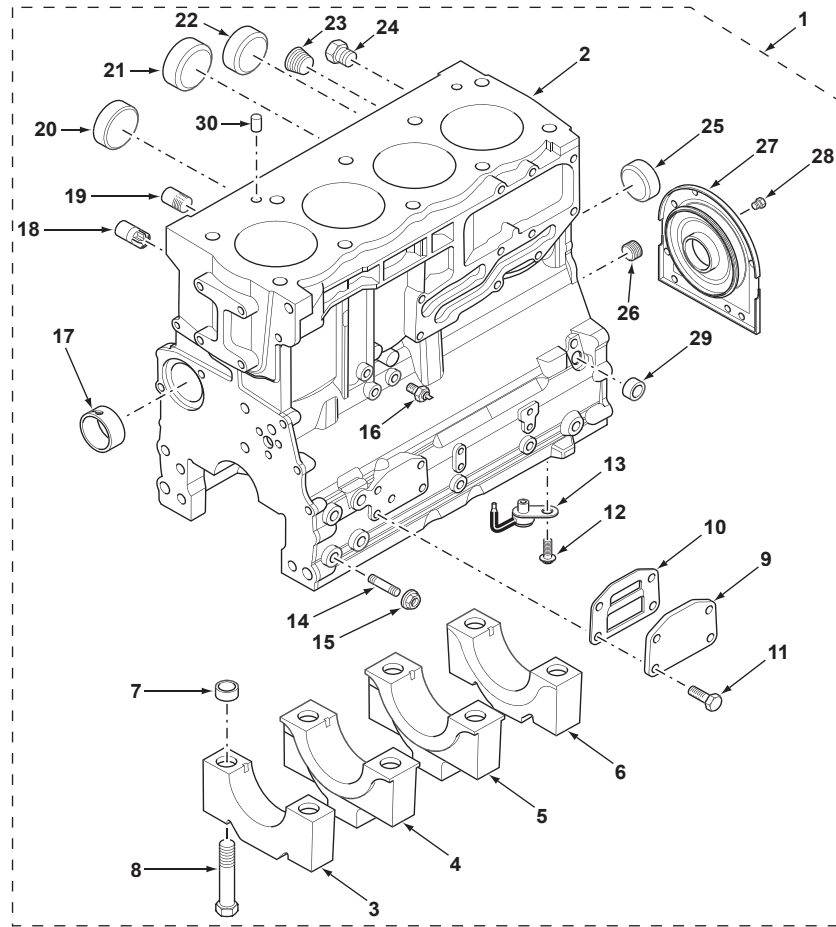

1	ZZ50311		1	Block, Cylinder	Bloc cylindres	Bloque cilindros
2		1	Ref. 1	Block, Cylinder	Bloc cylindres	Bloque cilindros
3		1	Ref. 1	Bearing, Support	Palier support	Palier soporte
4		1	Ref. 1	Bearing, Support	Palier support	Palier soporte
5		1	Ref. 1	Bearing, Support	Palier support	Palier soporte
6		1	Ref. 1	Bearing, Support	Palier support	Palier soporte
7	33142111	1		10 Ring, Centering	Bague de centrage	Anillo de centrado
8	32166329	1		10 Screw	Vis	Tornillo
9	3623A009	1		1 Plate	Plaque	Placa
10	3688A039	1		1 Joint	Articulation	Articulación
11	2314H033	1		4 Screw	Vis	Tornillo
12	2314F001	1		4 Screw	Vis	Tornillo
13	2113A001	1		4 Cooler	Refroidisseur	Enfriador
14	2313M101	1		8 Stud	Goujon	Espárrago
15	2318A605	1		8 Nut	Écrou	Tuerca
16	2848062	1		1 Probe	Sonde	Sonda
17	3112D071	1		1 Bush	Bague	Casquillo
18	3212V006	1		1 Plug	Bouchon	Tapón
19	3212V005	1		1 Plug	Bouchon	Tapón
20	2485A108	1		1 Plug, Blanking	Bouchon mâle, obturation	Tapón de bloqueo
21	3241A011	1		2 Plug	Bouchon	Tapón
22	0650710	1		1 Plug	Bouchon	Tapón
23	0650588	1		1 Plug	Bouchon	Tapón
24	32141316	1		2 Plug	Bouchon	Tapón
25	3241A012	1		1 Plug	Bouchon	Tapón
26	3212P008	1		1 Plug	Bouchon	Tapón
27	2418F704	1		1 Housing	Carter	Cárter
28	3211C002	1		10 Bolt	Boulon	Perno
29	2485A109	1		1 Plug	Bouchon	Tapón
30	3244A009	1		2 Pin, Dowel	Goupille position.	Peón



820
 TX760B

801 802 803 804 805 806 807 808 831 832 833 834

21010C02.1

6199042M3

1

Jan-06

Engine
 Moteur
 Motor

Cylinder Block
 Bloc Cylindres
 Bloque cilindros

RG38043
 RG38043
 RG38043

C-21011-02.1-A

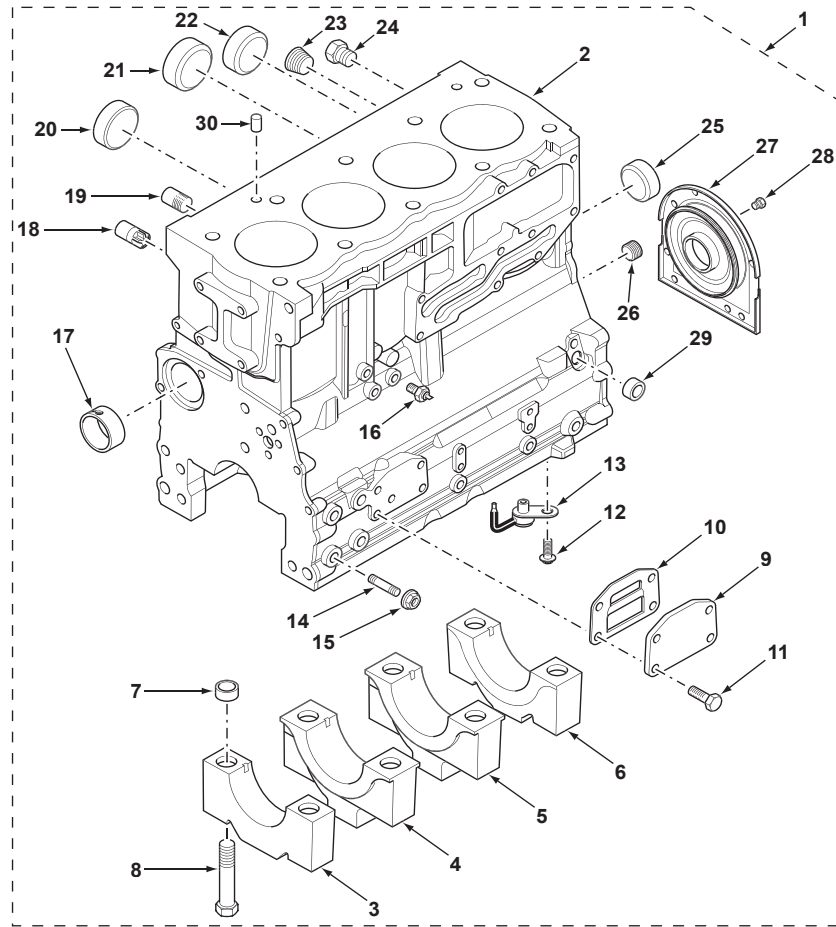

1	ZZ50311		1	Block, Cylinder	Bloc cylindres	Bloque cilindros
2		1	Ref. 1	Block, Cylinder	Bloc cylindres	Bloque cilindros
3		1	Ref. 1	Bearing, Support	Palier support	Palier soporte
4		1	Ref. 1	Bearing, Support	Palier support	Palier soporte
5		1	Ref. 1	Bearing, Support	Palier support	Palier soporte
6		1	Ref. 1	Bearing, Support	Palier support	Palier soporte
7	33142111	1	10	Ring, Centering	Bague de centrage	Anillo de centrado
8	32166329	1	10	Screw	Vis	Tornillo
9	3623A009	1	1	Plate	Plaque	Placa
10	3688A039	1	1	Joint	Articulation	Articulación
11	2314H033	1	4	Screw	Vis	Tornillo
12	2314F001	1	4	Screw	Vis	Tornillo
13	2113A001	1	4	Cooler	Refroidisseur	Enfriador
14	2313M101	1	8	Stud	Goujon	Espárrago
15	2318A605	1	8	Nut	Écrou	Tuerca
16	2848062	1	1	Probe	Sonde	Sonda
17	3112D071	1	1	Bush	Bague	Casquillo
18	3212V006	1	1	Plug	Bouchon	Tapón
19	3212V005	1	1	Plug	Bouchon	Tapón
20	2485A108	1	1	Plug, Blanking	Bouchon mâle, obturation	Tapón de bloqueo
21	3241A011	1	2	Plug	Bouchon	Tapón
22	0650710	1	1	Plug	Bouchon	Tapón
23	0650588	1	1	Plug	Bouchon	Tapón
24	32141316	1	2	Plug	Bouchon	Tapón
25	3241A012	1	1	Plug	Bouchon	Tapón
26	3212P008	1	1	Plug	Bouchon	Tapón
27	2418F704	1	1	Housing	Carter	Cárter
28	3211C002	1	10	Bolt	Boulon	Perno
29	2485A109	1	1	Plug	Bouchon	Tapón
30	3244A009	1	2	Pin, Dowel	Goupille position.	Peón



820
 TX760B

801 803 805 807 831 833

21011C02.1

6199042M3

1

Jan-06

Engine
Moteur
Motor

Cylinder Block
Bloc Cylindres
Bloque cilindros

RG38099
RG38099
RG38099

C-21012-02.1-A

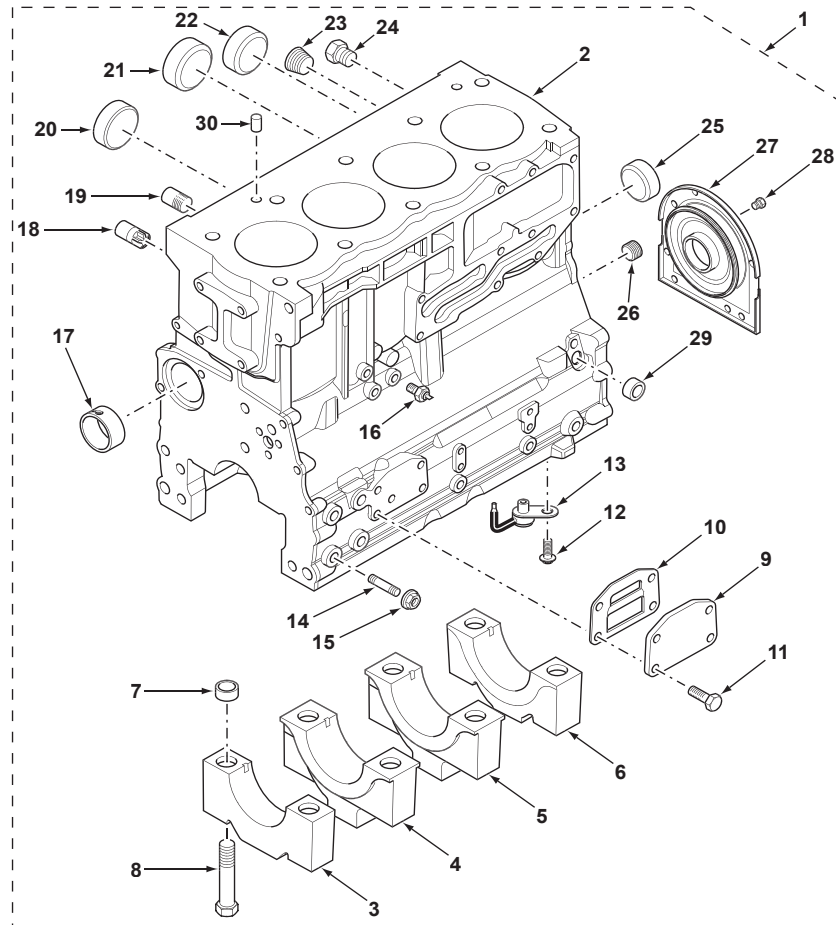

1	ZZ50311		1	Block, Cylinder	Bloc cylindres	Bloque cilindros
2		1	Ref. 1	Block, Cylinder	Bloc cylindres	Bloque cilindros
3		1	Ref. 1	Bearing, Support	Palier support	Palier soporte
4		1	Ref. 1	Bearing, Support	Palier support	Palier soporte
5		1	Ref. 1	Bearing, Support	Palier support	Palier soporte
6		1	Ref. 1	Bearing, Support	Palier support	Palier soporte
7	33142111	1		10 Ring, Centering	Bague de centrage	Anillo de centrado
8	32166329	1		10 Screw	Vis	Tornillo
9	3623A009	1		1 Plate	Plaque	Placa
10	3688A039	1		1 Joint	Articulation	Articulación
11	2314H033	1		4 Screw	Vis	Tornillo
12	2314F001	1		4 Screw	Vis	Tornillo
13	2113A001	1		4 Cooler	Refroidisseur	Enfriador
14	2313M101	1		8 Stud	Goujon	Espárrago
15	2318A605	1		8 Nut	Écrou	Tuerca
16	2848062	1		1 Probe	Sonde	Sonda
17	3112D071	1		1 Bush	Bague	Casquillo
18	3212V006	1		1 Plug	Bouchon	Tapón
19	3212V005	1		1 Plug	Bouchon	Tapón
20	2485A108	1		1 Plug, Blanking	Bouchon mâle, obturation	Tapón de bloqueo
21	3241A011	1		2 Plug	Bouchon	Tapón
22	0650710	1		1 Plug	Bouchon	Tapón
23	0650588	1		1 Plug	Bouchon	Tapón
24	32141316	1		2 Plug	Bouchon	Tapón
25	3241A012	1		1 Plug	Bouchon	Tapón
26	3212P008	1		1 Plug	Bouchon	Tapón
27	2418F704	1		1 Housing	Carter	Cárter
28	3211C002	1		10 Bolt	Boulon	Perno
29	2485A109	1		1 Plug	Bouchon	Tapón
30	3244A009	1		2 Pin, Dowel	Goupille position.	Peón



860 880 970 980
TX860B TX870B
TX970B

809 810 811 812 813 814 815 816 817 821 822 823 824 825 841 842 843 844 845
851 852 853 854 855 921 922 923 931 932

21012C02.1

6199042M3

1

Jan-06

Engine
Moteur
Motor

Cylinder Block
Bloc Cylindres
Bloque cilindros

RG38044
RG38044
RG38044

C-21013-02.1-A

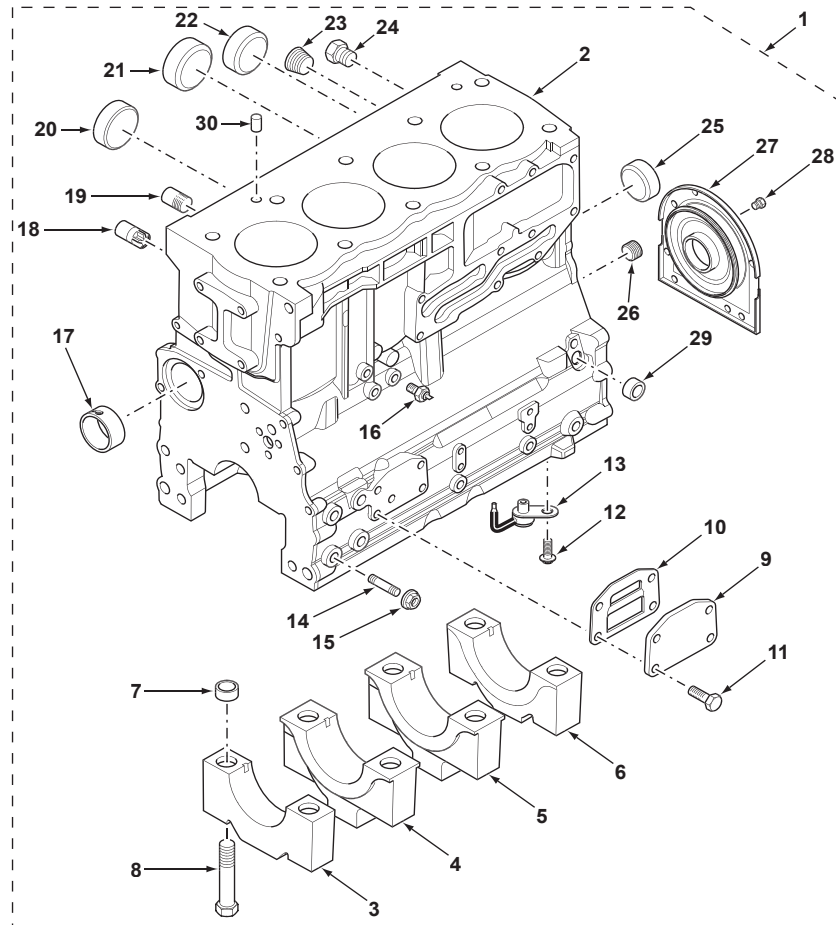

1	ZZ50311		1	Block, Cylinder	Bloc cylindres	Bloque cilindros
2		1	Ref. 1	Block, Cylinder	Bloc cylindres	Bloque cilindros
3		1	Ref. 1	Bearing, Support	Palier support	Palier soporte
4		1	Ref. 1	2 Bearing, Support	Palier support	Palier soporte
5		1	Ref. 1	Bearing, Support	Palier support	Palier soporte
6		1	Ref. 1	Bearing, Support	Palier support	Palier soporte
7	33142111	1		10 Ring, Centering	Bague de centrage	Anillo de centrado
8	32166329	1		10 Screw	Vis	Tornillo
9	3623A009	1		1 Plate	Plaque	Placa
10	3688A039	1		1 Joint	Articulation	Articulación
11	2314H033	1		4 Screw	Vis	Tornillo
12	2314F001	1		4 Screw	Vis	Tornillo
13	2113A001	1		4 Cooler	Refroidisseur	Enfriador
14	2313M101	1		8 Stud	Goujon	Espárrago
15	2318A605	1		8 Nut	Écrou	Tuerca
16	2848062	1		1 Probe	Sonde	Sonda
17	3112D071	1		1 Bush	Bague	Casquillo
18	3212V006	1		1 Plug	Bouchon	Tapón
19	3212V005	1		1 Plug	Bouchon	Tapón
20	2485A108	1		1 Plug, Blanking	Bouchon mâle, obturation	Tapón de bloqueo
21	3241A011	1		2 Plug	Bouchon	Tapón
22	0650710	1		1 Plug	Bouchon	Tapón
23	0650588	1		1 Plug	Bouchon	Tapón
24	32141316	1		2 Plug	Bouchon	Tapón
25	3241A012	1		1 Plug	Bouchon	Tapón
26	3212P008	1		1 Plug	Bouchon	Tapón
27	2418F704	1		1 Housing	Carter	Cárter
28	3211C002	1		10 Bolt	Boulon	Perno
29	2485A109	1		1 Plug	Bouchon	Tapón
30	3244A009	1		2 Pin, Dowel	Goupille position.	Peón



860 880 970 980
TX860B TX870B
TX970B

809 811 813 815 817 821 823 825 841 843 845 851 853 855 921 922 923 931 932

21013C02.1

6199042M3

1

Jan-06

Engine
Moteur
Motor

Cylinder Head
Culasse
Culata

RG38100
RG38100
RG38100

C-21010-04.1-A

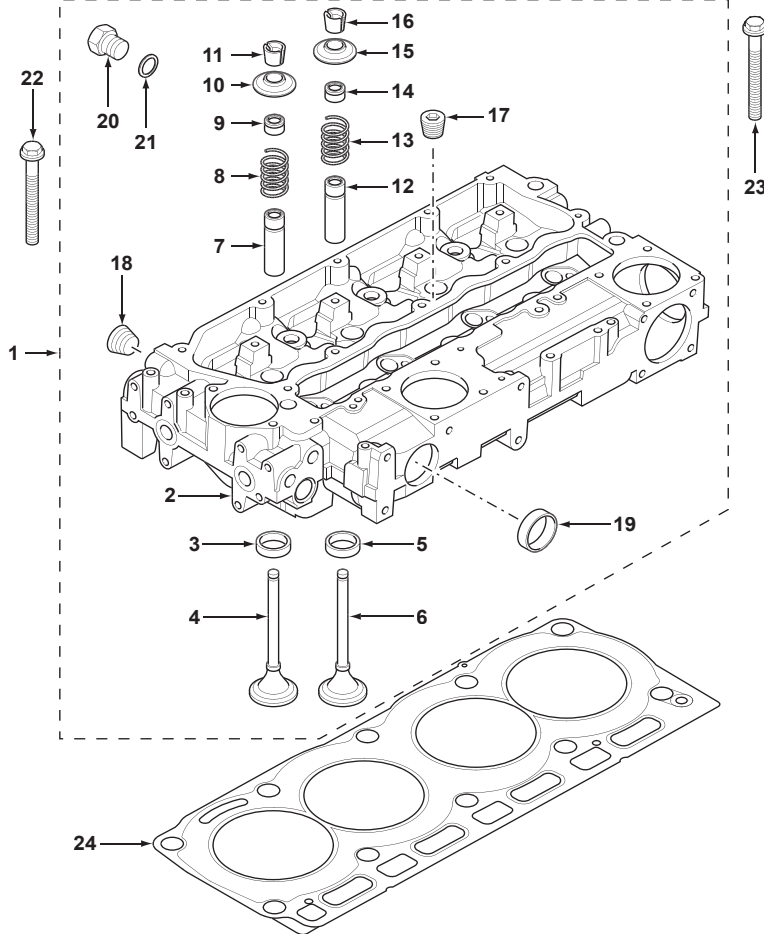

1	ZZ80268			1	Head, Cylinder	Culasse	Culata
2		1	➡ Ref. 1	1	Head, Cylinder	Culasse	Culata
3	3314A151	1		4	Insert	Insert	Inserción
4	3142H071	1		4	Valve, Intake	Soupape d'admission	Válvula de admisión
5	3314A161	1		4	Insert	Insert	Inserción
6	3142A151	1		4	Valve, Exhaust	Soupape d'échapp.	Válvula de escape
7	3313E021	1		4	Guide	Guide	Guía
8	3174A016	1		4	Spring, Valve	Ressort de soupape	Muelle, Válvula
9	2418M514	1		4	Ring, Sealing	Bague d'étanchéité	Anillo, Estanqueidad
10	3342A011	1		4	Cap	Chapeau	Sombbrero
11	3142W004	1		4	Retainer	Dispositif de retenue	Fijación
12	3313E021	1		4	Guide	Guide	Guía
13	3174A016	1		4	Spring, Valve	Ressort de soupape	Muelle, Válvula
14	2418M514	1		4	Ring, Sealing	Bague d'étanchéité	Anillo, Estanqueidad
15	3342A011	1		4	Cap	Chapeau	Sombbrero
16	3142W004	1		4	Retainer	Dispositif de retenue	Fijación
17	0650588	1		4	Plug	Bouchon	Tapón
18	2431154	1		1	Plug	Bouchon	Tapón
19	32416117	1		2	Plug	Bouchon	Tapón
20	3278A006	1		1	Plug	Bouchon	Tapón
21	2415H003	1		1	O-Ring	Joint torique	Junta de tipo O
22	3218A011			7	Bolt	Boulon	Perno
23	3218A012			3	Bolt	Boulon	Perno
24	3681E046			1	Gasket, Cyl. Head	Joint de culasse	Junta de culata



820
TX760B

801 802 803 804 805 806 807 808 831 832 833 834

21010C04.1

6199042M3

1

Jan-06

Engine
Moteur
Motor

Cylinder Head
Culasse
Culata

RG38043
RG38043
RG38043

C-21011-04.1-A

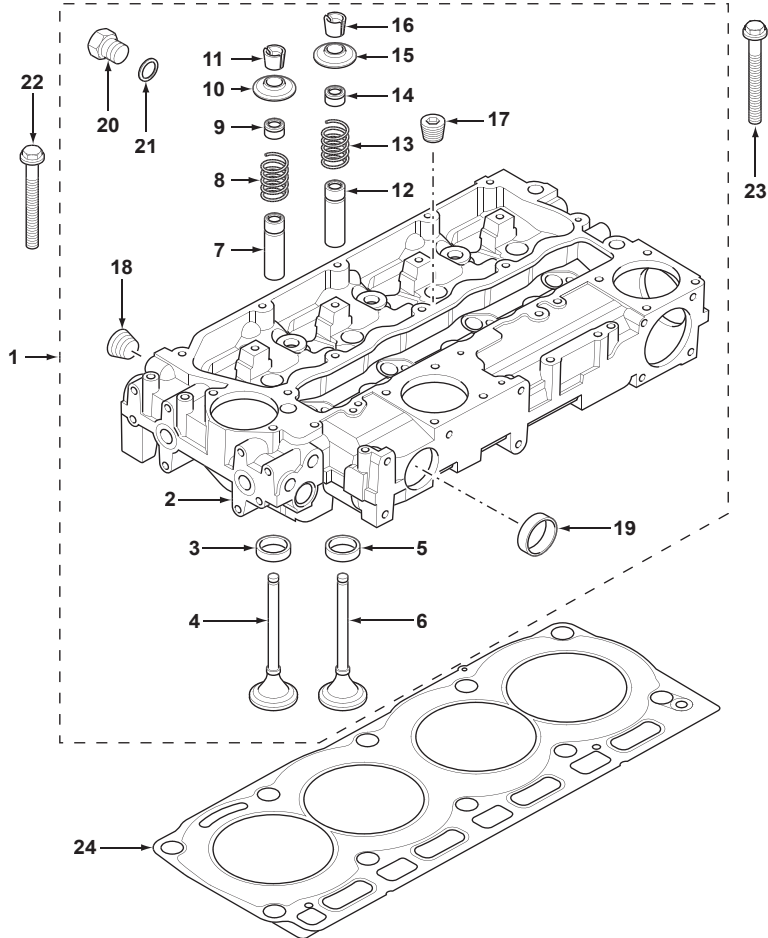

1	ZZ80268			1	Head, Cylinder	Culasse	Culata
2		1	➡ Ref. 1	1	Head, Cylinder	Culasse	Culata
3	3314A151	1		4	Insert	Insert	Inserción
4	3142H071	1		4	Valve, Intake	Soupape d'admission	Válvula de admisión
5	3314A161	1		4	Insert	Insert	Inserción
6	3142A151	1		4	Valve, Exhaust	Soupape d'échapp.	Válvula de escape
7	3313E021	1		4	Guide	Guide	Guía
8	3174A016	1		4	Spring, Valve	Ressort de soupape	Muelle, Válvula
9	2418M514	1		4	Ring, Sealing	Bague d'étanchéité	Anillo, Estanqueidad
10	3342A011	1		4	Cap	Chapeau	Sombbrero
11	3142W004	1		4	Retainer	Dispositif de retenue	Fijación
12	3313E021	1		4	Guide	Guide	Guía
13	3174A016	1		4	Spring, Valve	Ressort de soupape	Muelle, Válvula
14	2418M514	1		4	Ring, Sealing	Bague d'étanchéité	Anillo, Estanqueidad
15	3342A011	1		4	Cap	Chapeau	Sombbrero
16	3142W004	1		4	Retainer	Dispositif de retenue	Fijación
17	0650588	1		4	Plug	Bouchon	Tapón
18	2431154	1		1	Plug	Bouchon	Tapón
19	32416117	1		2	Plug	Bouchon	Tapón
20	3278A006	1		1	Plug	Bouchon	Tapón
21	2415H003	1		1	O-Ring	Joint torique	Junta de tipo O
22	3218A011			7	Bolt	Boulon	Perno
23	3218A012			3	Bolt	Boulon	Perno
24	3681E046			1	Gasket, Cyl. Head	Joint de culasse	Junta de culata



820
TX760B

801 803 805 807 831 833

21011C04.1

6199042M3

1

Jan-06

Engine
Moteur
Motor

Cylinder Head
Culasse
Culata

RG38099
RG38099
RG38099

C-21012-04.1-A

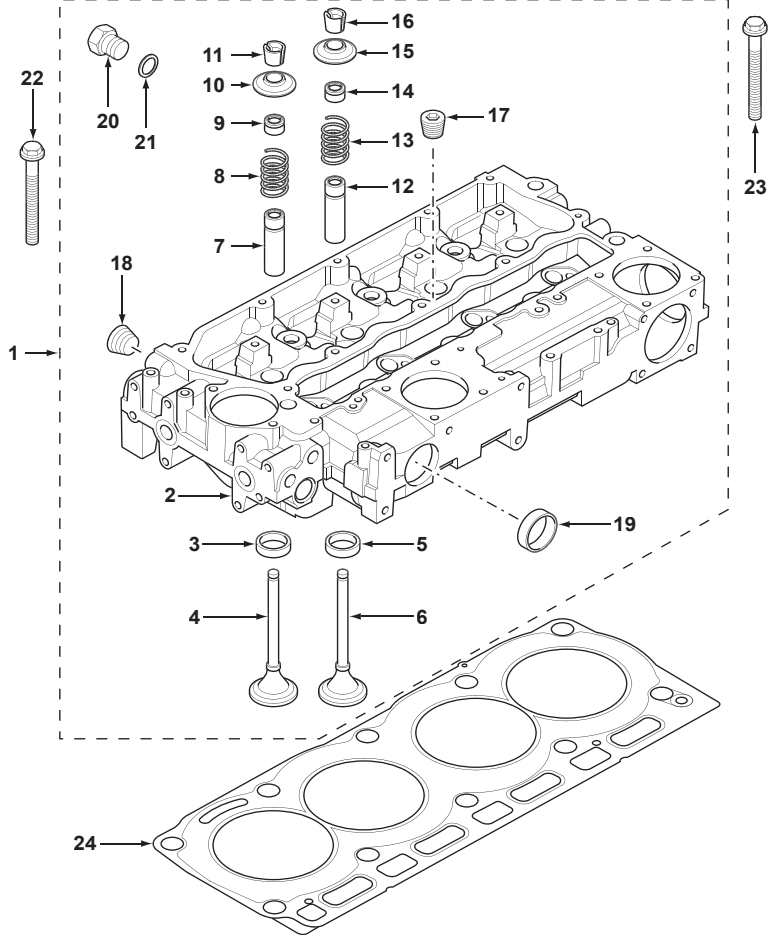

1	ZZ80268			1	Head, Cylinder	Culasse	Culata
2		1	➡ Ref. 1	1	Head, Cylinder	Culasse	Culata
3	3314A151	1		4	Insert	Insert	Inserción
4	3142H071	1		4	Valve, Intake	Soupape d'admission	Válvula de admisión
5	3314A161	1		4	Insert	Insert	Inserción
6	3142A151	1		4	Valve, Exhaust	Soupape d'échapp.	Válvula de escape
7	3313E021	1		4	Guide	Guide	Guía
8	3174A016	1		4	Spring, Valve	Ressort de soupape	Muelle, Válvula
9	2418M514	1		4	Ring, Sealing	Bague d'étanchéité	Anillo, Estanqueidad
10	3342A011	1		4	Cap	Chapeau	Sombbrero
11	3142W004	1		4	Retainer	Dispositif de retenue	Fijación
12	3313E021	1		4	Guide	Guide	Guía
13	3174A016	1		4	Spring, Valve	Ressort de soupape	Muelle, Válvula
14	2418M514	1		4	Ring, Sealing	Bague d'étanchéité	Anillo, Estanqueidad
15	3342A011	1		4	Cap	Chapeau	Sombbrero
16	3142W004	1		4	Retainer	Dispositif de retenue	Fijación
17	0650588	1		4	Plug	Bouchon	Tapón
18	2431154	1		1	Plug	Bouchon	Tapón
19	32416117	1		2	Plug	Bouchon	Tapón
20	3278A006	1		1	Plug	Bouchon	Tapón
21	2415H003	1		1	O-Ring	Joint torique	Junta de tipo O
22	3218A011			7	Bolt	Boulon	Perno
23	3218A012			3	Bolt	Boulon	Perno
24	3681E046			1	Gasket, Cyl. Head	Joint de culasse	Junta de culata



860 880 970 980
TX860B TX870B
TX970B

809 810 811 812 813 814 815 816 817 821 822 823 824 825 841 842 843 844 845
851 852 853 854 855 921 922 923 931 932

21012C04.1

6199042M3

1

Jan-06

Engine
Moteur
Motor

Cylinder Head
Culasse
Culata

RG38044
RG38044
RG38044

C-21013-04.1-A

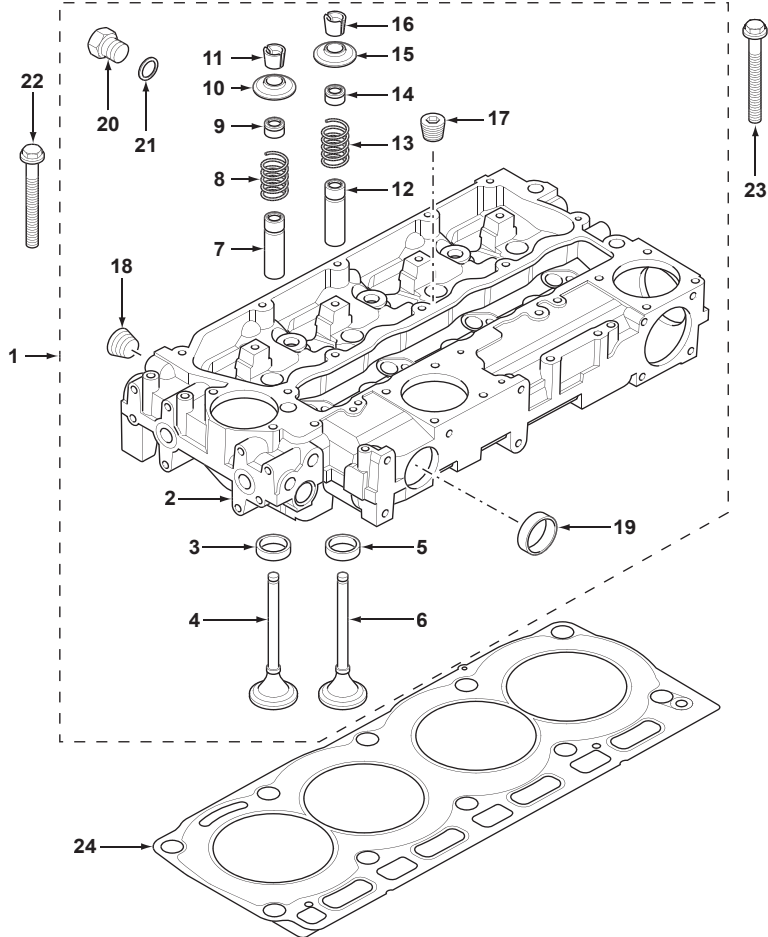

1	ZZ80268			1	Head, Cylinder	Culasse	Culata
2		1	➡ Ref. 1	1	Head, Cylinder	Culasse	Culata
3	3314A151	1		4	Insert	Insert	Inserción
4	3142H071	1		4	Valve, Intake	Soupape d'admission	Válvula de admisión
5	3314A161	1		4	Insert	Insert	Inserción
6	3142A151	1		4	Valve, Exhaust	Soupape d'échapp.	Válvula de escape
7	3313E021	1		4	Guide	Guide	Guía
8	3174A016	1		4	Spring, Valve	Ressort de soupape	Muelle, Válvula
9	2418M514	1		4	Ring, Sealing	Bague d'étanchéité	Anillo, Estanqueidad
10	3342A011	1		4	Cap	Chapeau	Sombbrero
11	3142W004	1		4	Retainer	Dispositif de retenue	Fijación
12	3313E021	1		4	Guide	Guide	Guía
13	3174A016	1		4	Spring, Valve	Ressort de soupape	Muelle, Válvula
14	2418M514	1		4	Ring, Sealing	Bague d'étanchéité	Anillo, Estanqueidad
15	3342A011	1		4	Cap	Chapeau	Sombbrero
16	3142W004	1		4	Retainer	Dispositif de retenue	Fijación
17	0650588	1		4	Plug	Bouchon	Tapón
18	2431154	1		1	Plug	Bouchon	Tapón
19	32416117	1		2	Plug	Bouchon	Tapón
20	3278A006	1		1	Plug	Bouchon	Tapón
21	2415H003	1		1	O-Ring	Joint torique	Junta de tipo O
22	3218A011			7	Bolt	Boulon	Perno
23	3218A012			3	Bolt	Boulon	Perno
24	3681E046			1	Gasket, Cyl. Head	Joint de culasse	Junta de culata



860 880 970 980
TX860B TX870B
TX970B

809 811 813 815 817 821 823 825 841 843 845 851 853 855 921 922 923 931 932

21013C04.1

6199042M3

1

Jan-06

Engine
Moteur
Motor

Engine Installation
Montage du Moteur
Instalación motor

RG38100
RG38100
RG38100

C-21010-01.1-B

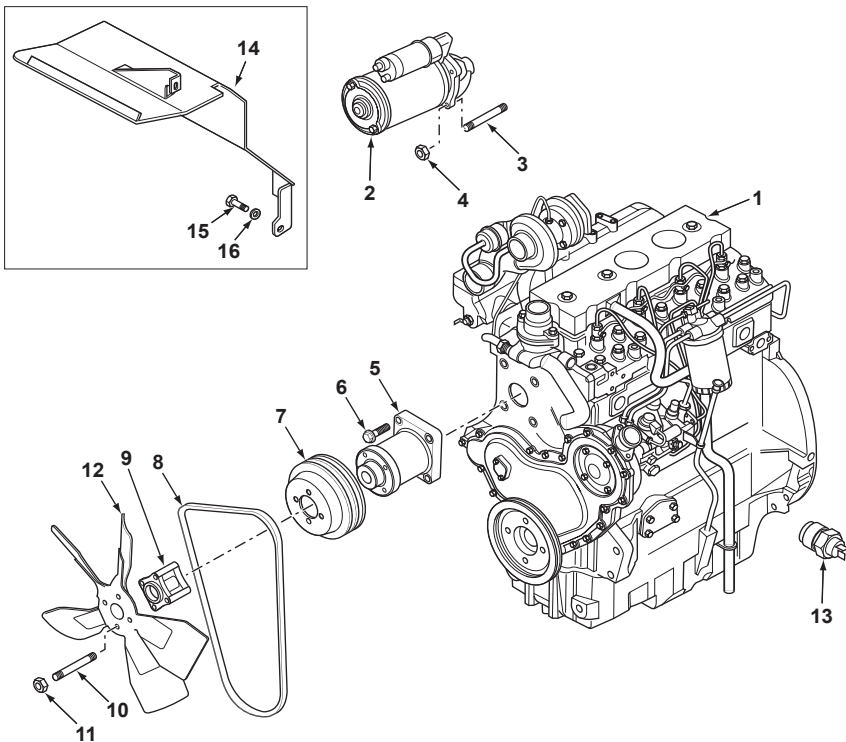

1	6110149M91	90HP	1	Engine Assy	Ensemble de moteur thermique	Motor térmico, Conj.
2	2873K404	1	1	Starter Motor	Démarrreur	Arrancador
3	2313C078	1	3	Stud	Goujon	Espárrago
4	2318A604	1	3	Nut	Écrou	Tuerca
5	4113K005	1	1	Housing Assy	Ensemble de carter	Cárter, Conj.
6	2314J005	1	4	Bolt	Boulon	Perno
7	3115C113	1	1	Pulley	Poulie	Polea
8	2614B650	1	2	Belt, V	Courroie trapézoïdale	Correa trapezoidal
9	3748W223	1	1	Extension	Rallonge	Extensión
10	2313H229	1	4	Stud	Goujon	Espárrago
11	2318D208	1	4	Nut	Écrou	Tuerca
12	6110111M91		1	Fan	Ventilateur	Ventilador
13	6110201M91	Water Temp.	1	Sensor	Capteur	Captador
14	6110369M4		1	Deflector	Défecteur	Deflector
15	3009491X1	M10 x 20	2	Screw	Vis	Tornillo
16	390734X1	M10	2	Washer	Rondelle	Arandela



820
TX760B

801 802 803 804 805 806 807 808 831 832 833 834

21010C01.1

6199042M3

1

Jan-06

Engine
Moteur
Motor

Engine Installation
Montage du Moteur
Instalación motor

RG38043
RG38043
RG38043

C-21011-01.1-B

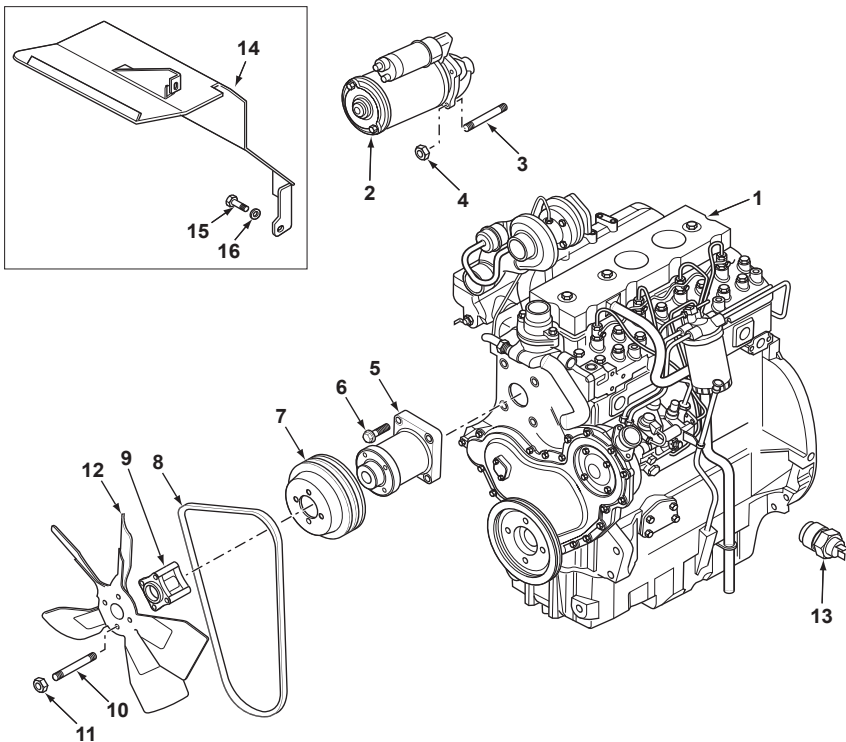

1	6109946M91	90HP	1	Engine Assy	Ensemble de moteur thermique	Motor térmico, Conj.
2	2873K404	1	1	Starter Motor	Démarrreur	Arrancador
3	2313C078	1	3	Stud	Goujon	Espárrago
4	2318A604	1	3	Nut	Écrou	Tuerca
5	4113K005	1	1	Housing Assy	Ensemble de carter	Cárter, Conj.
6	2314J005	1	4	Bolt	Boulon	Perno
7	3115C113	1	1	Pulley	Poulie	Polea
8	2614B650	1	2	Belt, V	Courroie trapézoïdale	Correa trapezoidal
9	3748W223	1	1	Extension	Rallonge	Extensión
10	2313H229	1	4	Stud	Goujon	Espárrago
11	2318D208	1	4	Nut	Écrou	Tuerca
12	6110111M91		1	Fan	Ventilateur	Ventilador
13	6110201M91	Water Temp.	1	Sensor	Capteur	Captador
14	6110369M4		1	Deflector	Défecteur	Deflector
15	3009491X1	M10 x 20	2	Screw	Vis	Tornillo
16	390734X1	M10	2	Washer	Rondelle	Arandela



820
TX760B

801 803 805 807 831 833

21011C01.1

6199042M3

1

Jan-06

Engine
Moteur
Motor

Engine Installation
Montage du Moteur
Instalación motor

RG38099
RG38099
RG38099

C-21012-01.1-B

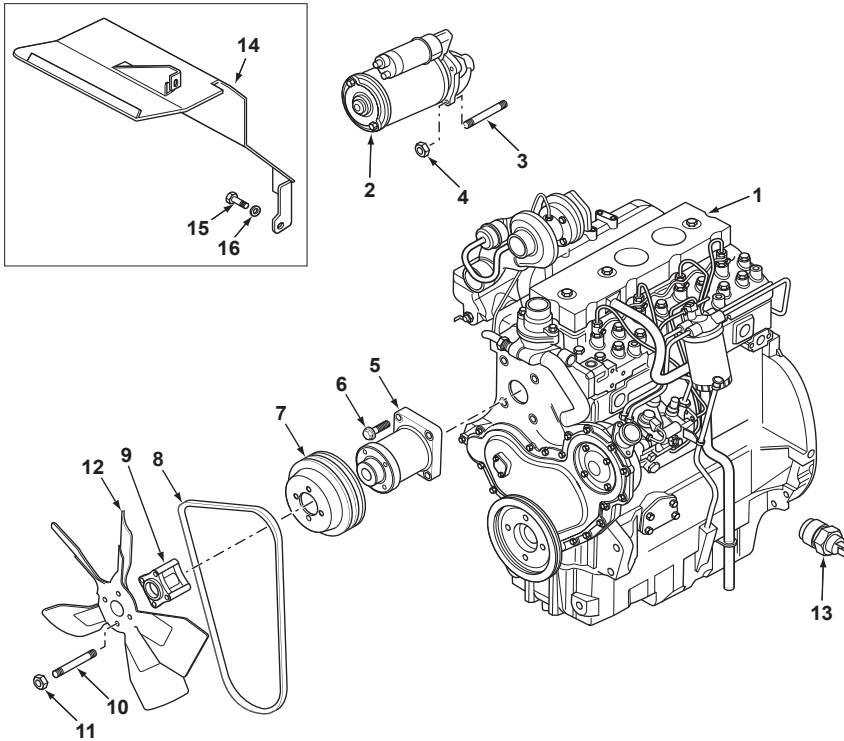

1	6110150M91		100HP	1	Engine Assy	Ensemble de moteur thermique	Motor térmico, Conj.
2	2873K404	1		1	Starter Motor	Démarrreur	Arrancador
3	2313C078	1		3	Stud	Goujon	Espárrago
4	2318A604	1		3	Nut	Écrou	Tuerca
5	4113K005	1		1	Housing Assy	Ensemble de carter	Cárter, Conj.
6	2314J005	1		4	Bolt	Boulon	Perno
7	3115C113	1		1	Pulley	Poulie	Polea
8	2614B650	1		2	Belt, V	Courroie trapézoïdale	Correa trapezoidal
9	3748W223	1		1	Extension	Rallonge	Extensión
10	2313H229	1		4	Stud	Goujon	Espárrago
11	2318D208	1		4	Nut	Écrou	Tuerca
12	6110111M91			1	Fan	Ventilateur	Ventilador
13	6110201M91		Water Temp.	1	Sensor	Capteur	Captador
14	6110369M4			1	Deflector	Défecteur	Deflector
15	3009491X1		M10 x 20	2	Screw	Vis	Tornillo
16	390734X1		M10	2	Washer	Rondelle	Arandela



860 880 970 980
TX860B TX870B
TX970B

809 810 811 812 813 814 815 816 817 821 822 823 824 825 841 842 843 844 845
851 852 853 854 855 921 922 923 931 932

21012C01.1

6199042M3

1

Jan-06

Engine
Moteur
Motor

Engine Installation
Montage du Moteur
Instalación motor

RG38044
RG38044
RG38044

C-21013-01.1-B

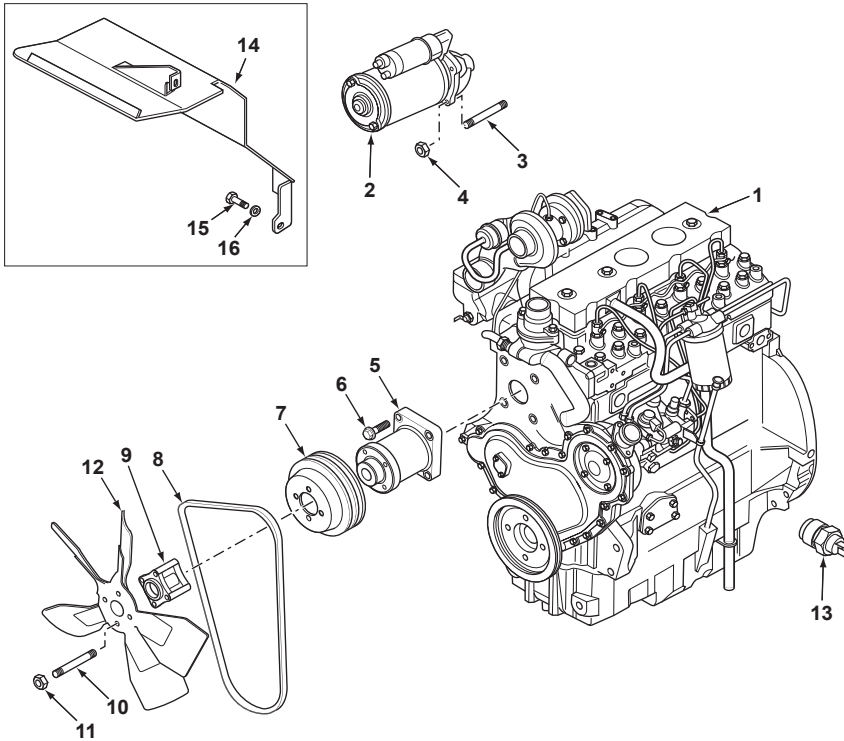

1	6109945M91		100HP	1	Engine Assy	Ensemble de moteur thermique	Motor térmico, Conj.
2	2873K404	1		1	Starter Motor	Démarrreur	Arrancador
3	2313C078	1		3	Stud	Goujon	Espárrago
4	2318A604	1		3	Nut	Écrou	Tuerca
5	4113K005	1		1	Housing Assy	Ensemble de carter	Cárter, Conj.
6	2314J005	1		4	Bolt	Boulon	Perno
7	3115C113	1		1	Pulley	Poulie	Polea
8	2614B650	1		2	Belt, V	Courroie trapézoïdale	Correa trapezoidal
9	3748W223	1		1	Extension	Rallonge	Extensión
10	2313H229	1		4	Stud	Goujon	Espárrago
11	2318D208	1		4	Nut	Écrou	Tuerca
12	6110111M91			1	Fan	Ventilateur	Ventilador
13	6110201M91		Water Temp.	1	Sensor	Capteur	Captador
14	6110369M4			1	Deflector	Défecteur	Deflector
15	3009491X1		M10 x 20	2	Screw	Vis	Tornillo
16	390734X1		M10	2	Washer	Rondelle	Arandela



860 880 970 980
TX860B TX870B
TX970B

809 811 813 815 817 821 823 825 841 843 845 851 853 855 921 922 923 931 932

21013C01.1

6199042M3

1

Jan-06

Engine
Moteur
Motor

Engine Lifting
Levage Moteur Thermique
Placas levantadoras del motor térmico

RG38100
RG38100
RG38100

C-21010-23.1-A

1	3617A015		1	Ring, Lifting	Anneau de levage	Anillo de elevación
2	2314J002	M10 x 20	2	Screw	Vis	Tornillo
3	3624A016		1	Ring, Lifting	Anneau de levage	Anillo de elevación
4	2314J002	M10 x 20	2	Screw	Vis	Tornillo

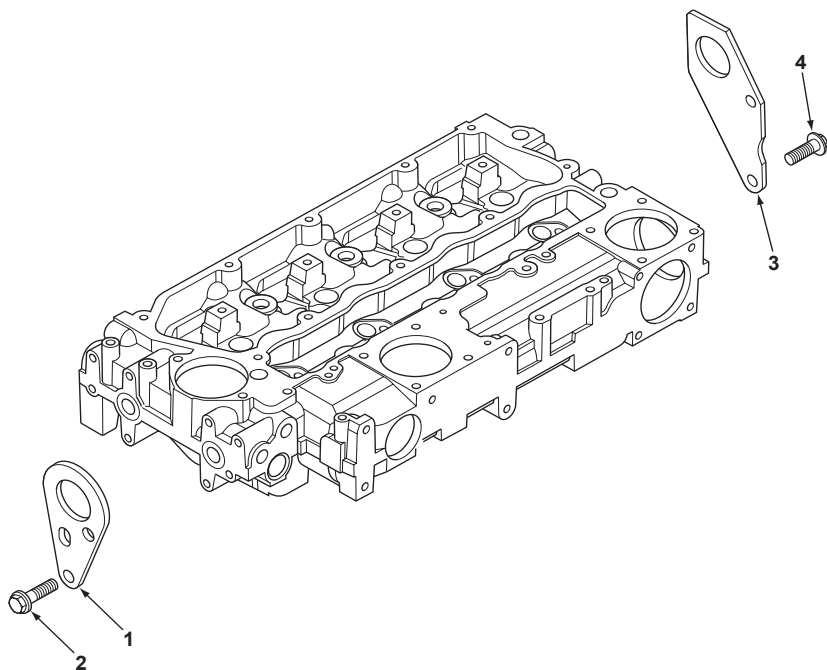

820
TX760B

801 802 803 804 805 806 807 808 831 832 833 834

21010C23.1

6199042M3

1

Jan-06

Engine
Moteur
Motor

Engine Lifting
Levage Moteur Thermique
Placas levantadoras del motor térmico

RG38043
RG38043
RG38043

C-21011-23.1-A

1	3617A015		1	Ring, Lifting	Anneau de levage	Anillo de elevación
2	2314J002	M10 x 20	2	Screw	Vis	Tornillo
3	3624A016		1	Ring, Lifting	Anneau de levage	Anillo de elevación
4	2314J002	M10 x 20	2	Screw	Vis	Tornillo

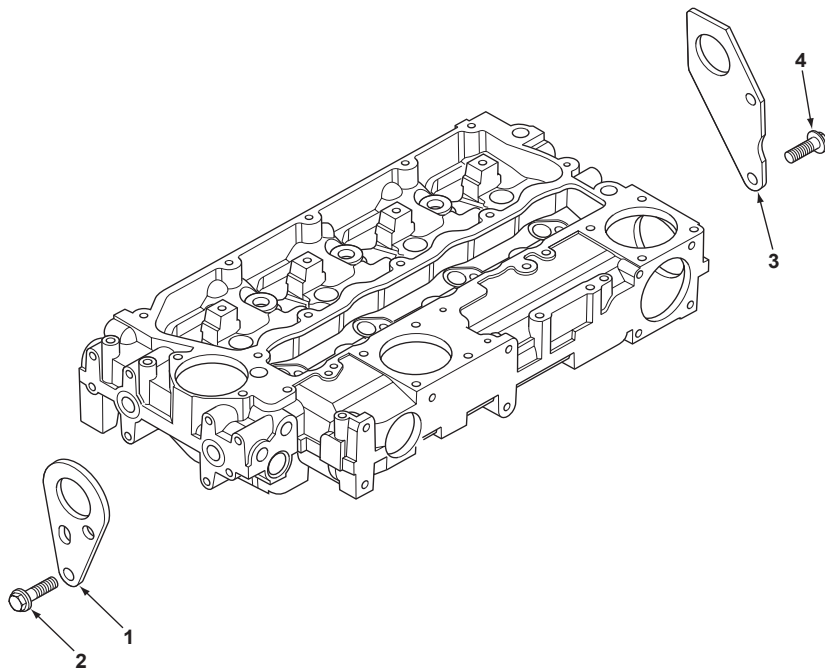

820
TX760B

801 803 805 807 831 833

21011C23.1

6199042M3

1

Jan-06

Engine
Moteur
Motor

Engine Lifting
Levage Moteur Thermique
Placas levantadoras del motor térmico

RG38099
RG38099
RG38099

C-21012-23.1-A

1	3617A015		1	Ring, Lifting	Anneau de levage	Anillo de elevación
2	2314J002	M10 x 20	2	Screw	Vis	Tornillo
3	3624A016		1	Ring, Lifting	Anneau de levage	Anillo de elevación
4	2314J002	M10 x 20	2	Screw	Vis	Tornillo

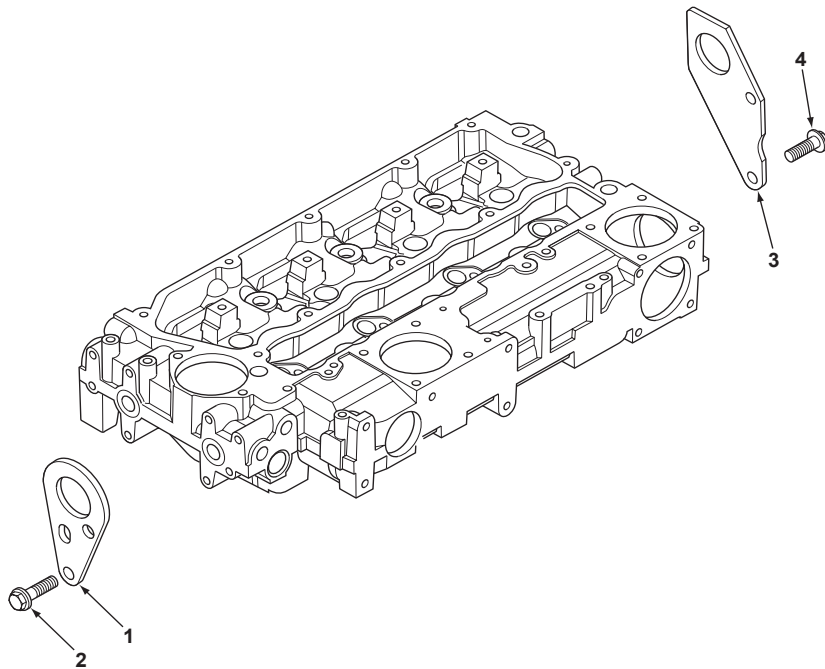

860 880 970 980
TX860B TX870B
TX970B

809 810 811 812 813 814 815 816 817 821 822 823 824 825 841 842 843 844 845
851 852 853 854 855 921 922 923 931 932

Engine
Moteur
Motor

Engine Lifting
Levage Moteur Thermique
Placas levantadoras del motor térmico

RG38044
RG38044
RG38044

C-21013-23.1-A

1	3617A015		1	Ring, Lifting	Anneau de levage	Anillo de elevación
2	2314J002	M10 x 20	2	Screw	Vis	Tornillo
3	3624A016		1	Ring, Lifting	Anneau de levage	Anillo de elevación
4	2314J002	M10 x 20	2	Screw	Vis	Tornillo

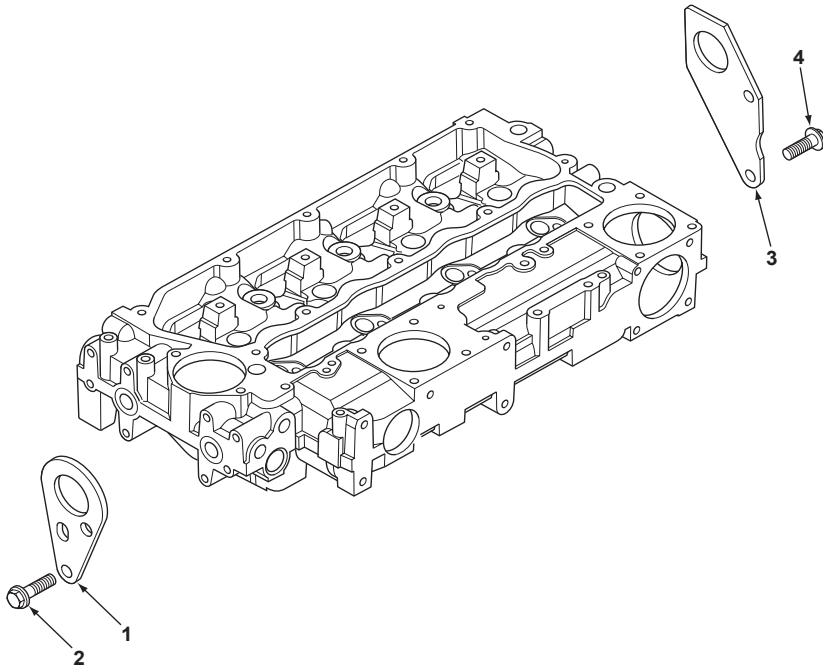

860 880 970 980
TX860B TX870B
TX970B

809 811 813 815 817 821 823 825 841 843 845 851 853 855 921 922 923 931 932

21013C23.1

6199042M3

1

Jan-06

Engine
Moteur
Motor

Exhaust Pipe
Collecteur d'échappement
Colector de escape

RG38100
RG38100
RG38100

C-21010-09.1-A

1	3778E221			1	Manifold	Collecteur	Colector
2	3681V512			1	Joint	Articulation	Articulación
3	3218J013		M10 x 30	8	Screw	Vis	Tornillo

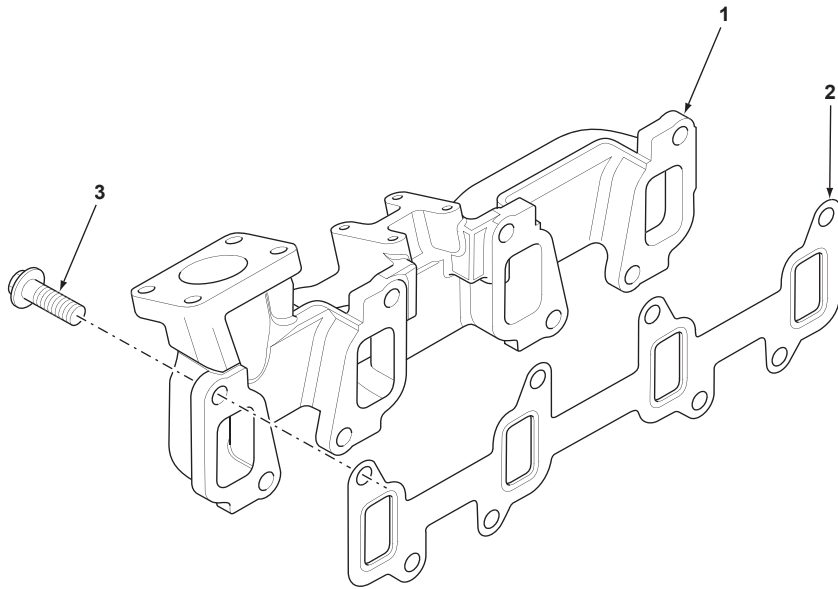

820
TX760B

801 802 803 804 805 806 807 808 831 832 833 834

21010C09.1

6199042M3

1

Jan-06

Engine
Moteur
Motor

Exhaust Pipe
Collecteur d'échappement
Colector de escape

RG38043
RG38043
RG38043

C-21011-09.1-A

1	3778E221		1	Manifold	Collecteur	Colector
2	3681V512		1	Joint	Articulation	Articulación
3	3218J013	M10 x 30	8	Screw	Vis	Tornillo

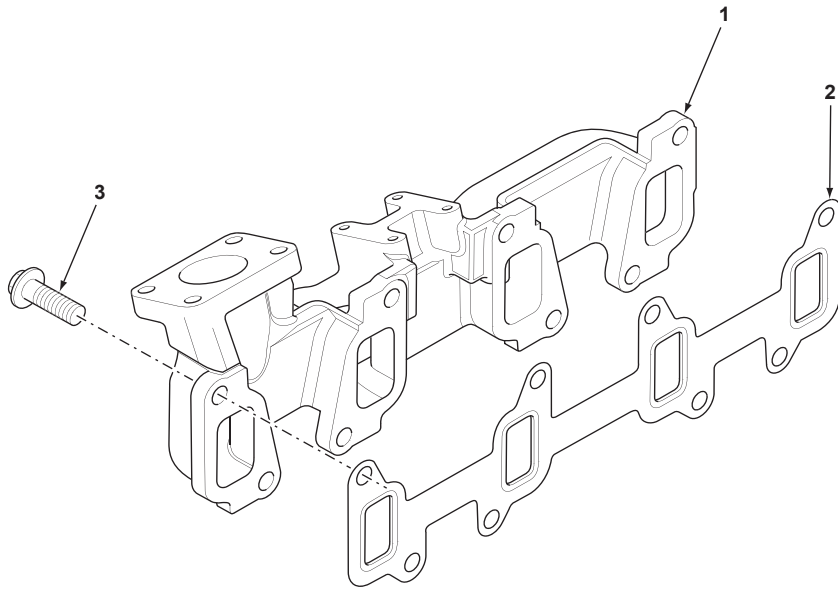

820
TX760B

801 803 805 807 831 833

21011C09.1

6199042M3

1

Jan-06

Engine
Moteur
Motor

Exhaust Pipe
Collecteur d'échappement
Colector de escape

RG38099
RG38099
RG38099

C-21012-09.1-A

1	3778E221		1	Manifold	Collecteur	Colector
2	3681V512		1	Joint	Articulation	Articulación
3	3218J013	M10 x 30	8	Screw	Vis	Tornillo

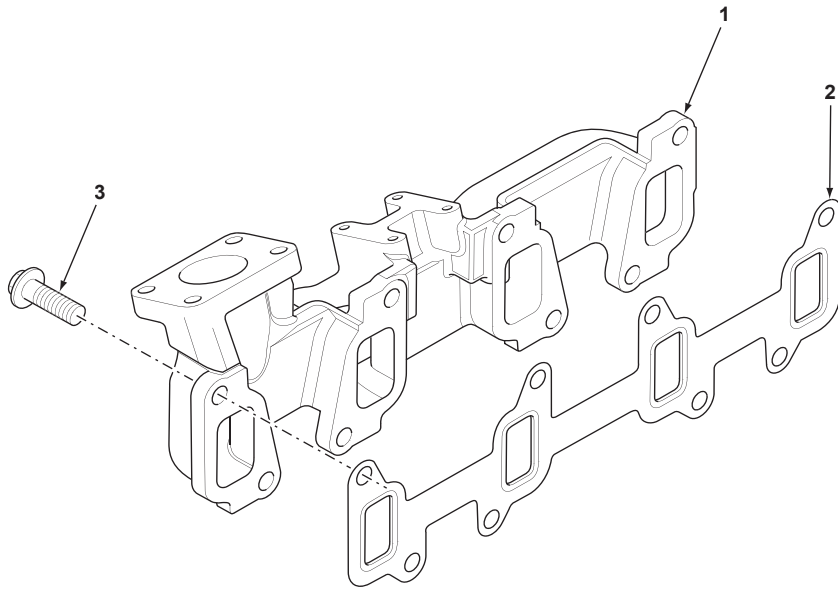

860 880 970 980
TX860B TX870B
TX970B

809 810 811 812 813 814 815 816 817 821 822 823 824 825 841 842 843 844 845
851 852 853 854 855 921 922 923 931 932

21012C09.1

6199042M3

1

Jan-06

Engine
Moteur
Motor

Exhaust Pipe
Collecteur d'échappement
Colector de escape

RG38044
RG38044
RG38044

C-21013-09.1-A

1	3778E221		1	Manifold	Collecteur	Colector
2	3681V512		1	Joint	Articulation	Articulación
3	3218J013	M10 x 30	8	Screw	Vis	Tornillo

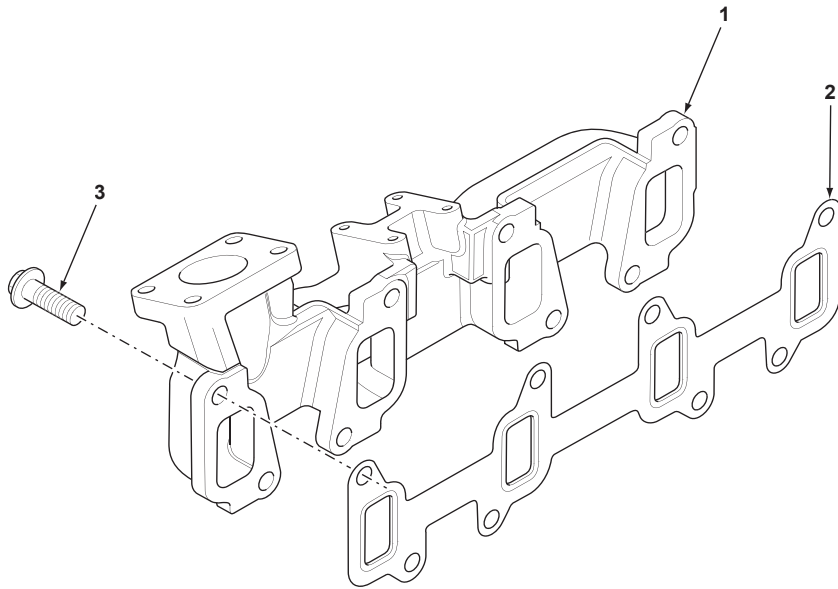

860 880 970 980
TX860B TX870B
TX970B

809 811 813 815 817 821 823 825 841 843 845 851 853 855 921 922 923 931 932

21013C09.1

6199042M3

1

Jan-06

Engine
Moteur
Motor

Filter With Fuel Separator
Filtre/Séparateur de Carburant
Filtro/separador de carburante

RG38100
RG38100
RG38100

C-21010-20.1-A

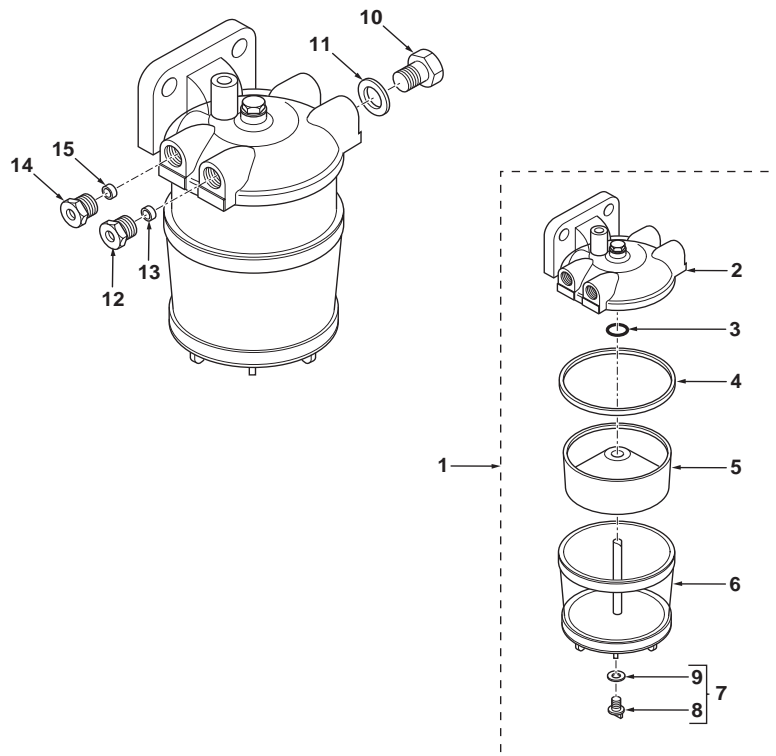

1	2656086			1	Filter, Fuel	Filtre à carburant	Filtro combustible
2		1	➡ Ref. 1	1	Head	Tête	Cabeza
3	26560016	1		1	Washer	Rondelle	Arandela
4	0490786	1		2	Seal	Joint	Junta
5	26560156	1		1	Separator	Séparateur	Separador
6	26560075	1		1	Bowl	Cuve	Cuba
7	26560614	1		1	Plug	Bouchon	Tapón
8		7	➡ Ref. 7	1	Plug	Bouchon	Tapón
9	26431192	7		1	Washer	Rondelle	Arandela
10	0650204			2	Plug	Bouchon	Tapón
11	0920154			2	Washer	Rondelle	Arandela
12	33532129			1	Nut, Tube	Écrou de tuyauterie	Tuerca de tubería
13	0566004			1	Olive	Olive	Oliva
14	33532129			1	Nut, Tube	Écrou de tuyauterie	Tuerca de tubería
15	0566004			1	Olive	Olive	Oliva



820
TX760B

801 802 803 804 805 806 807 808 831 832 833 834

21010C20.1

6199042M3

1

Jan-06

Engine
Moteur
Motor

Filter With Fuel Separator
Filtre/Séparateur de Carburant
Filtro/separador de carburante

RG38043
RG38043
RG38043

C-21011-20.1-A

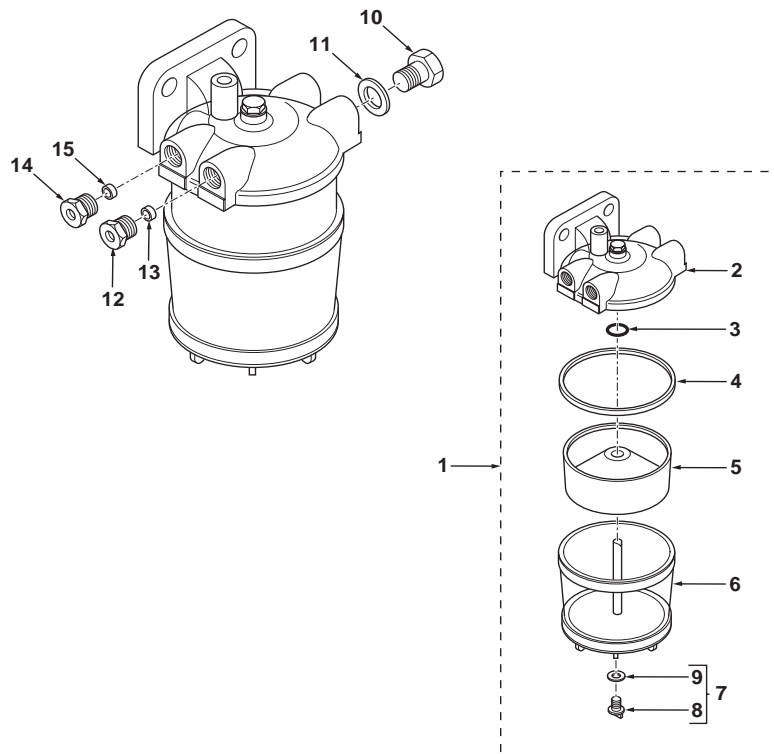

1	2656086			1	Filter, Fuel	Filtre à carburant	Filtro combustible
2		1	➡ Ref. 1	1	Head	Tête	Cabeza
3	26560016	1		1	Washer	Rondelle	Arandela
4	0490786	1		2	Seal	Joint	Junta
5	26560156	1		1	Separator	Séparateur	Separador
6	26560075	1		1	Bowl	Cuve	Cuba
7	26560614	1		1	Plug	Bouchon	Tapón
8		7	➡ Ref. 7	1	Plug	Bouchon	Tapón
9	26431192	7		1	Washer	Rondelle	Arandela
10	0650204			2	Plug	Bouchon	Tapón
11	0920154			2	Washer	Rondelle	Arandela
12	33532129			1	Nut, Tube	Écrou de tuyauterie	Tuerca de tubería
13	0566004			1	Olive	Olive	Oliva
14	33532129			1	Nut, Tube	Écrou de tuyauterie	Tuerca de tubería
15	0566004			1	Olive	Olive	Oliva



820
TX760B

801 803 805 807 831 833

21011C20.1

6199042M3

1

Jan-06

Engine
Moteur
Motor

Filter With Fuel Separator
Filtre/Séparateur de Carburant
Filtro/separador de carburante

RG38099
RG38099
RG38099

C-21012-20.1-A

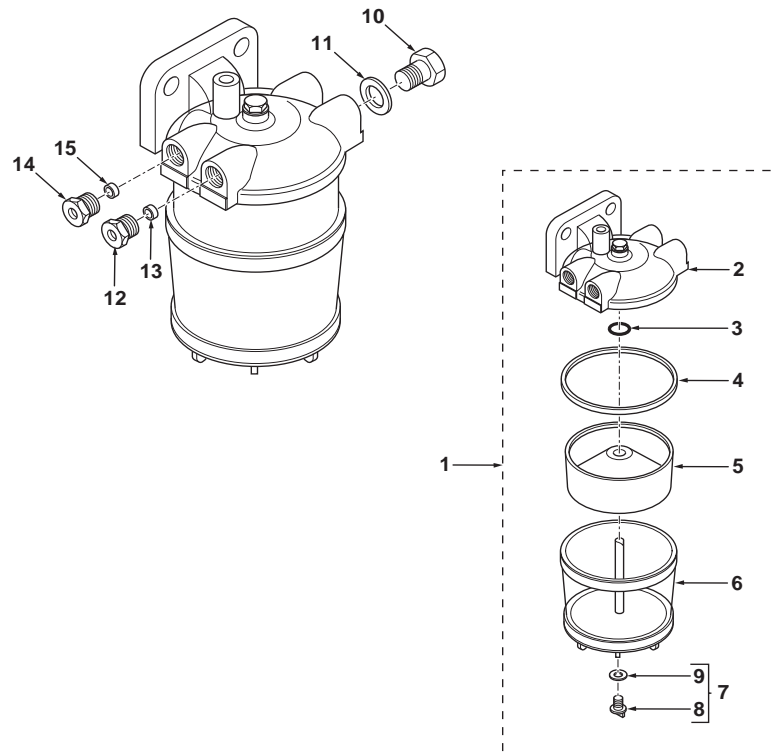

1	2656086			1	Filter, Fuel	Filtre à carburant	Filtro combustible
2		1	➡ Ref. 1	1	Head	Tête	Cabeza
3	26560016	1		1	Washer	Rondelle	Arandela
4	0490786	1		2	Seal	Joint	Junta
5	26560156	1		1	Separator	Séparateur	Separador
6	26560075	1		1	Bowl	Cuve	Cuba
7	26560614	1		1	Plug	Bouchon	Tapón
8		7	➡ Ref. 7	1	Plug	Bouchon	Tapón
9	26431192	7		1	Washer	Rondelle	Arandela
10	0650204			2	Plug	Bouchon	Tapón
11	0920154			2	Washer	Rondelle	Arandela
12	33532129			1	Nut, Tube	Écrou de tuyauterie	Tuerca de tubería
13	0566004			1	Olive	Olive	Oliva
14	33532129			1	Nut, Tube	Écrou de tuyauterie	Tuerca de tubería
15	0566004			1	Olive	Olive	Oliva



860 880 970 980
TX860B TX870B
TX970B

809 810 811 812 813 814 815 816 817 821 822 823 824 825 841 842 843 844 845
851 852 853 854 855 921 922 923 931 932

21012C20.1

6199042M3

1

Jan-06

Engine
Moteur
Motor

Filter With Fuel Separator
Filtre/Séparateur de Carburant
Filtro/separador de carburante

RG38044
RG38044
RG38044

C-21013-20.1-A

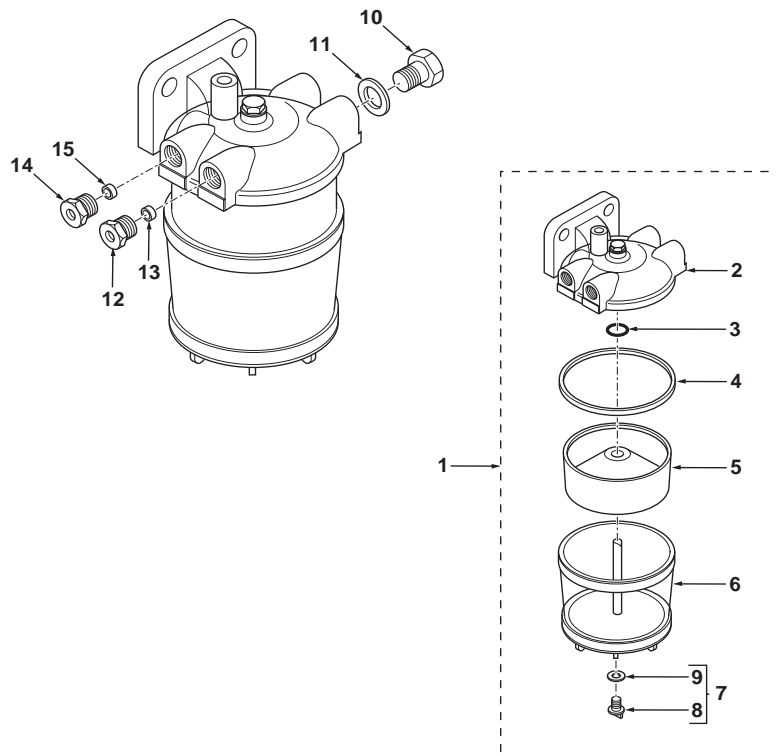

1	2656086			1	Filter, Fuel	Filtre à carburant	Filtro combustible
2		1	➡ Ref. 1	1	Head	Tête	Cabeza
3	26560016	1		1	Washer	Rondelle	Arandela
4	0490786	1		2	Seal	Joint	Junta
5	26560156	1		1	Separator	Séparateur	Separador
6	26560075	1		1	Bowl	Cuve	Cuba
7	26560614	1		1	Plug	Bouchon	Tapón
8		7	➡ Ref. 7	1	Plug	Bouchon	Tapón
9	26431192	7		1	Washer	Rondelle	Arandela
10	0650204			2	Plug	Bouchon	Tapón
11	0920154			2	Washer	Rondelle	Arandela
12	33532129			1	Nut, Tube	Écrou de tuyauterie	Tuerca de tubería
13	0566004			1	Olive	Olive	Oliva
14	33532129			1	Nut, Tube	Écrou de tuyauterie	Tuerca de tubería
15	0566004			1	Olive	Olive	Oliva



860 880 970 980
TX860B TX870B
TX970B

809 811 813 815 817 821 823 825 841 843 845 851 853 855 921 922 923 931 932

21013C20.1

6199042M3

1

Jan-06

Engine
Moteur
Motor

Flywheel
Volant Moteur
Volante

RG38100
RG38100
RG38100

C-21010-13.1-A

1	4111D127			1	Flywheel	Volant moteur	Volante motor
2		1	 Ref. 1	1	Flywheel	Volant moteur	Volante motor
3	31162121	1		1	Ring, Gear	Couronne dentée	Corona dentada
4	0746853			6	Screw	Vis	Tornillo
5	33117127			6	Washer	Rondelle	Arandela

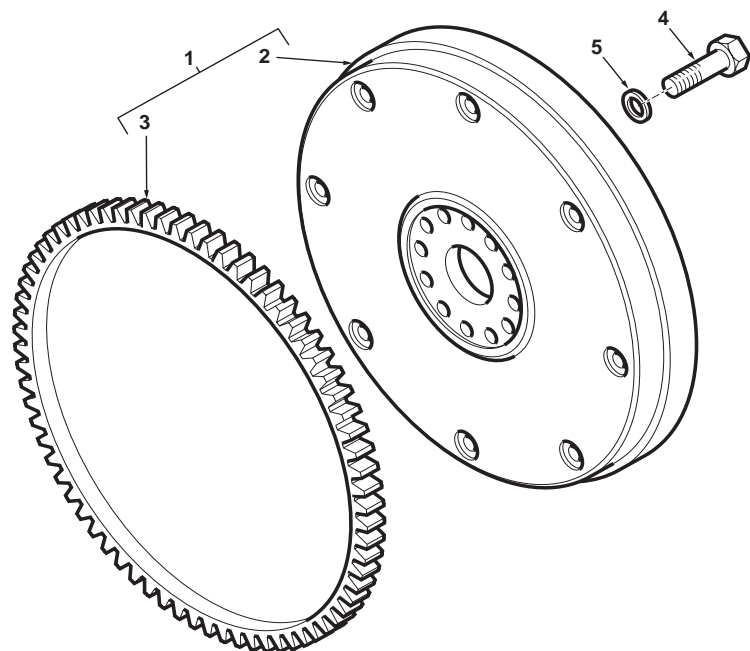

820
TX760B

801 802 803 804 805 806 807 808 831 832 833 834

21010C13.1

6199042M3

1

Jan-06

Engine
Moteur
Motor

Flywheel
Volant Moteur
Volante

RG38043
RG38043
RG38043

C-21011-13.1-A

1	4111D127			1	Flywheel	Volant moteur	Volante motor
2		1	 Ref. 1	1	Flywheel	Volant moteur	Volante motor
3	31162121	1		1	Ring, Gear	Couronne dentée	Corona dentada
4	0746853			6	Screw	Vis	Tornillo
5	33117127			6	Washer	Rondelle	Arandela

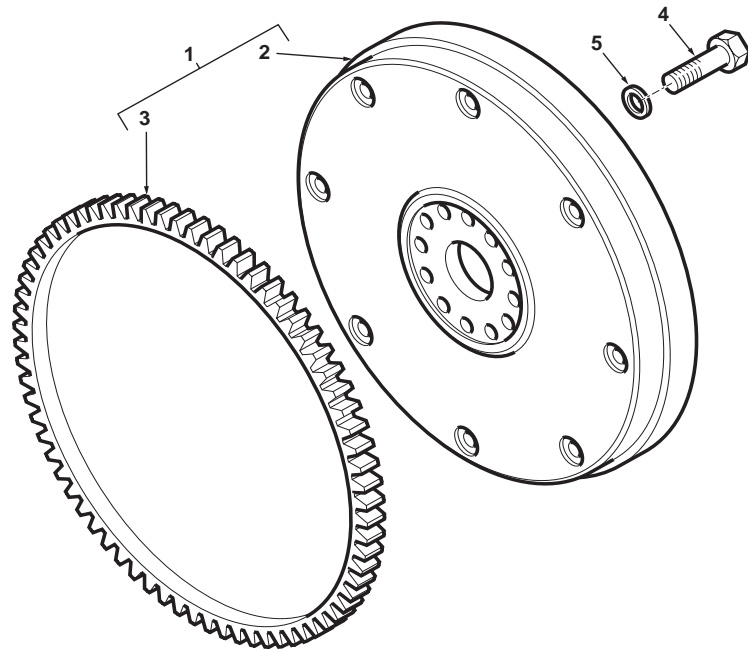

820
TX760B

801 803 805 807 831 833

21011C13.1

6199042M3

1

Jan-06

Engine
Moteur
Motor

Flywheel
Volant Moteur
Volante

RG38099
RG38099
RG38099

C-21012-13.1-A

1	4111D127			1	Flywheel	Volant moteur	Volante motor
2		1	 Ref. 1	1	Flywheel	Volant moteur	Volante motor
3	31162121	1		1	Ring, Gear	Couronne dentée	Corona dentada
4	0746853			6	Screw	Vis	Tornillo
5	33117127			6	Washer	Rondelle	Arandela

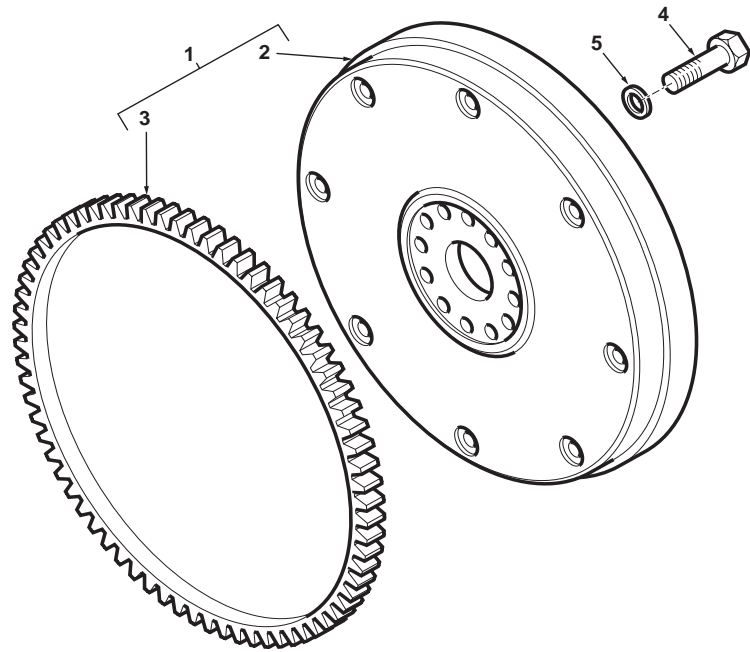

860 880 970 980
TX860B TX870B
TX970B

809 810 811 812 813 814 815 816 817 821 822 823 824 825 841 842 843 844 845
851 852 853 854 855 921 922 923 931 932

21012C13.1

6199042M3

1

Jan-06

Engine
Moteur
Motor

Flywheel
Volant Moteur
Volante

RG38044
RG38044
RG38044

C-21013-13.1-A

1	4111D127			1	Flywheel	Volant moteur	Volante motor
2		1	Ref. 1	1	Flywheel	Volant moteur	Volante motor
3	31162121	1		1	Ring, Gear	Couronne dentée	Corona dentada
4	0746853			6	Screw	Vis	Tornillo
5	33117127			6	Washer	Rondelle	Arandela

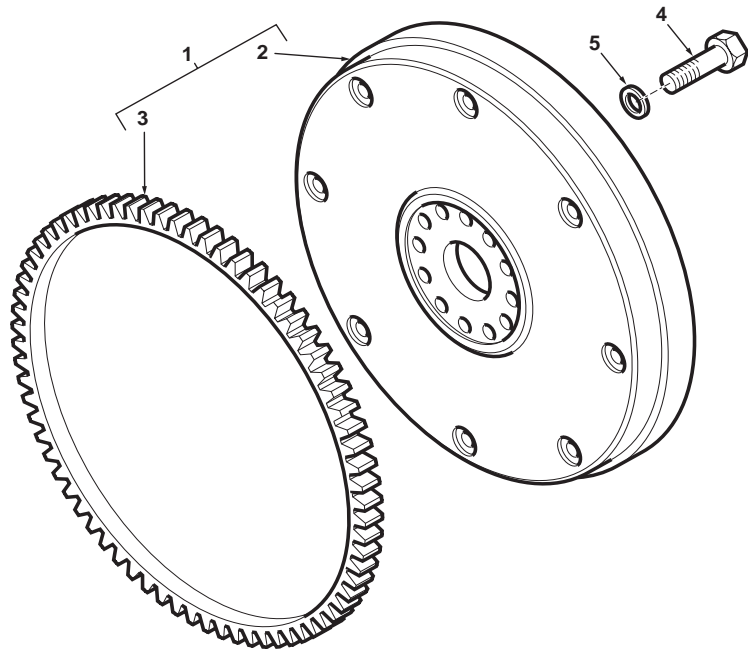

860 880 970 980
TX860B TX870B
TX970B

809 811 813 815 817 821 823 825 841 843 845 851 853 855 921 922 923 931 932

21013C13.1

6199042M3

1

Jan-06

Engine
Moteur
Motor

Flywheel Housing
Volant Moteur Carter
Volante Cártér

RG38100
RG38100
RG38100

C-21010-14.1-A

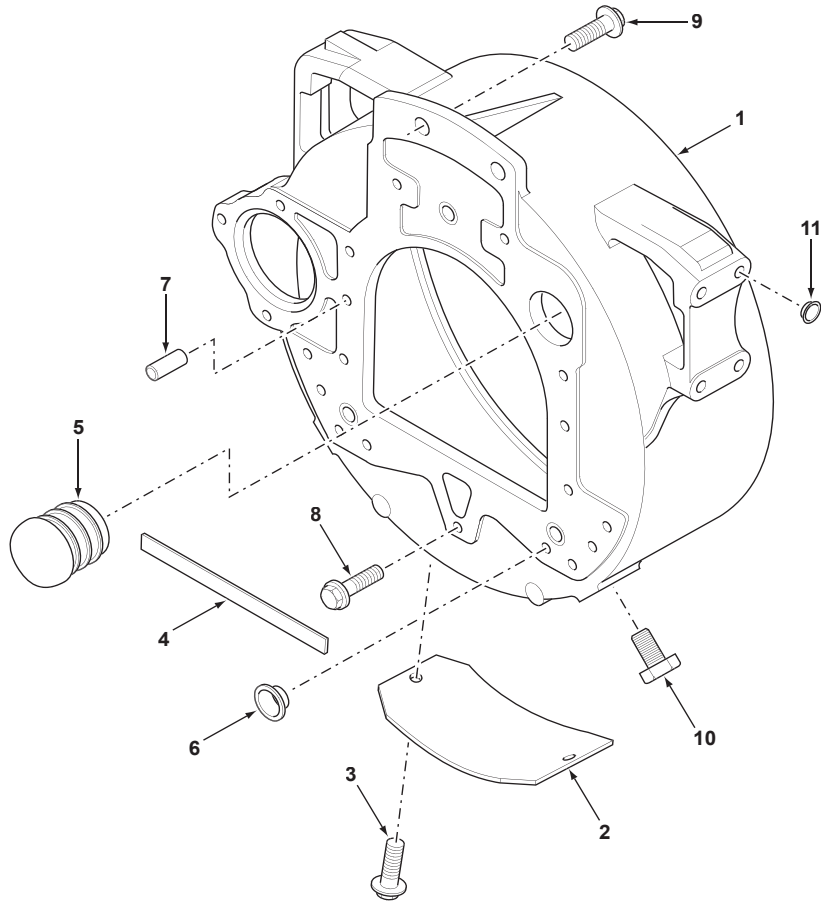

1	3713M049			1	Housing	Carter	Cártér
2	36212132			1	Plate	Plaque	Placa
3	2314H102			2	Screw	Vis	Tornillo
4	36843154			1	Seal	Joint	Junta
5	2487A452			1	Plug, Blanking	Bouchon mâle, obturation	Tapón de bloqueo
6	2487204			3	Plug	Bouchon	Tapón
7	0350025			2	Pin, Dowel	Goupille position.	Peón
8	2314J204			6	Screw	Vis	Tornillo
9	2314J603			2	Screw	Vis	Tornillo
10	2487Y005			2	Plug	Bouchon	Tapón
11	2487207			10	Plug	Bouchon	Tapón



820
TX760B

801 802 803 804 805 806 807 808 831 832 833 834

21010C14.1

6199042M3

1

Jan-06

Engine
Moteur
Motor

Flywheel Housing
Volant Moteur Carter
Volante Cártér

RG38043
RG38043
RG38043

C-21011-14.1-A

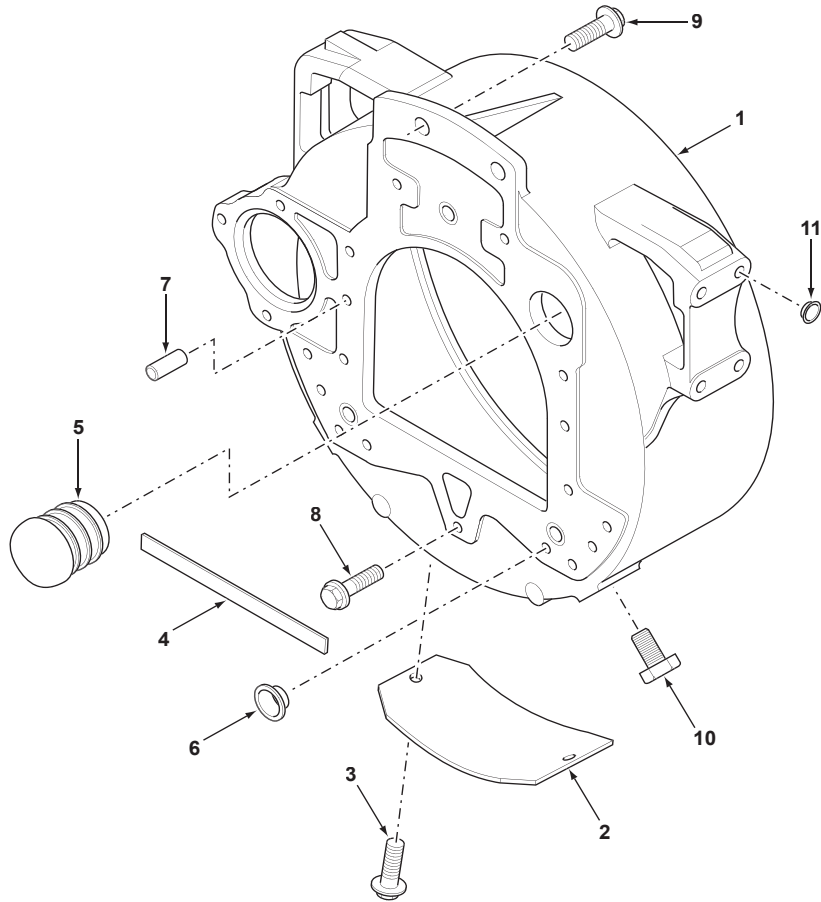

1	3713M049			1	Housing	Carter	Cártér
2	36212132			1	Plate	Plaque	Placa
3	2314H102			2	Screw	Vis	Tornillo
4	36843154			1	Seal	Joint	Junta
5	2487A452			1	Plug, Blanking	Bouchon mâle, obturation	Tapón de bloqueo
6	2487204			3	Plug	Bouchon	Tapón
7	0350025			2	Pin, Dowel	Goupille position.	Peón
8	2314J204			6	Screw	Vis	Tornillo
9	2314J603			2	Screw	Vis	Tornillo
10	2487Y005			2	Plug	Bouchon	Tapón
11	2487207			10	Plug	Bouchon	Tapón



820
TX760B

801 803 805 807 831 833

21011C14.1

6199042M3

1

Jan-06

Engine
Moteur
Motor

Flywheel Housing
Volant Moteur Carter
Volante Cártér

RG38099
RG38099
RG38099

C-21012-14.1-A

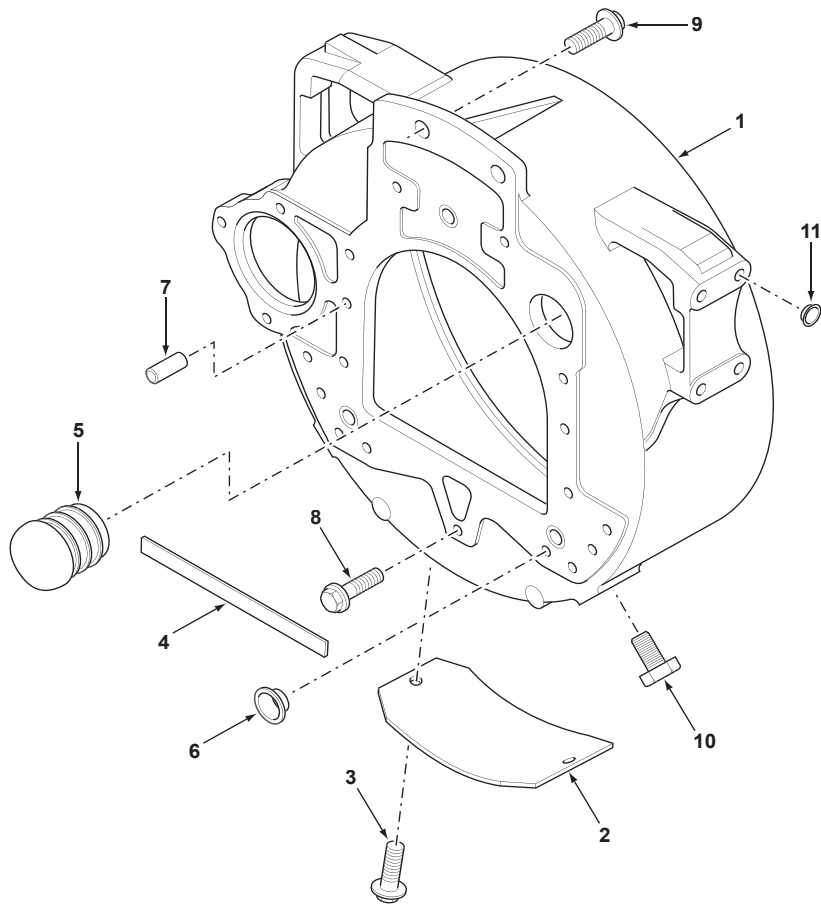

1	3713M049			1	Housing	Carter	Cártér
2	36212132			1	Plate	Plaque	Placa
3	2314H102			2	Screw	Vis	Tornillo
4	36843154			1	Seal	Joint	Junta
5	2487A452			1	Plug, Blanking	Bouchon mâle, obturation	Tapón de bloqueo
6	2487204			3	Plug	Bouchon	Tapón
7	0350025			2	Pin, Dowel	Goupille position.	Peón
8	2314J204			6	Screw	Vis	Tornillo
9	2314J603			2	Screw	Vis	Tornillo
10	2487Y005			2	Plug	Bouchon	Tapón
11	2487207			10	Plug	Bouchon	Tapón



860 880 970 980
TX860B TX870B
TX970B

809 810 811 812 813 814 815 816 817 821 822 823 824 825 841 842 843 844 845
851 852 853 854 855 921 922 923 931 932

21012C14.1

6199042M3

1

Jan-06

Engine
Moteur
Motor

Flywheel Housing
Volant Moteur Carter
Volante Cártér

RG38044
RG38044
RG38044

C-21013-14.1-A

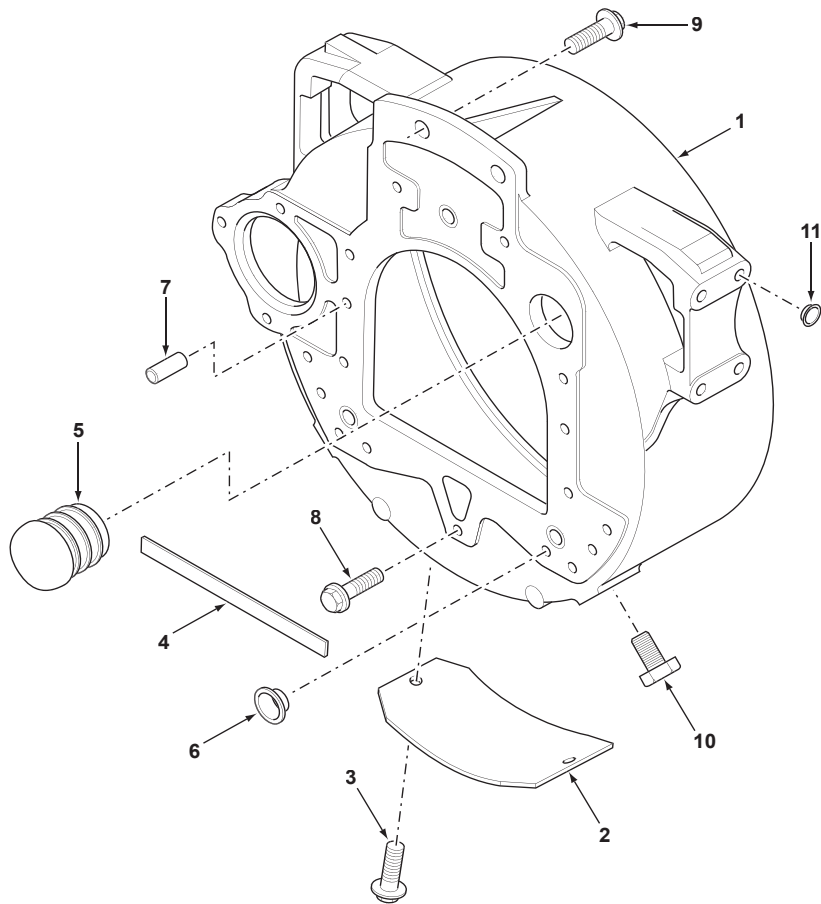

1	3713M049			1	Housing	Carter	Cártér
2	36212132			1	Plate	Plaque	Placa
3	2314H102			2	Screw	Vis	Tornillo
4	36843154			1	Seal	Joint	Junta
5	2487A452			1	Plug, Blanking	Bouchon mâle, obturation	Tapón de bloqueo
6	2487204			3	Plug	Bouchon	Tapón
7	0350025			2	Pin, Dowel	Goupille position.	Peón
8	2314J204			6	Screw	Vis	Tornillo
9	2314J603			2	Screw	Vis	Tornillo
10	2487Y005			2	Plug	Bouchon	Tapón
11	2487207			10	Plug	Bouchon	Tapón



860 880 970 980
TX860B TX870B
TX970B

809 811 813 815 817 821 823 825 841 843 845 851 853 855 921 922 923 931 932

21013C14.1

6199042M3

1

Jan-06

Engine
Moteur
Motor

Fuel Lift Pump
Pompe d'alimentation de Carburant
Bomba de alimentación de carburante

RG38100
RG38100
RG38100

C-21010-19.1-A

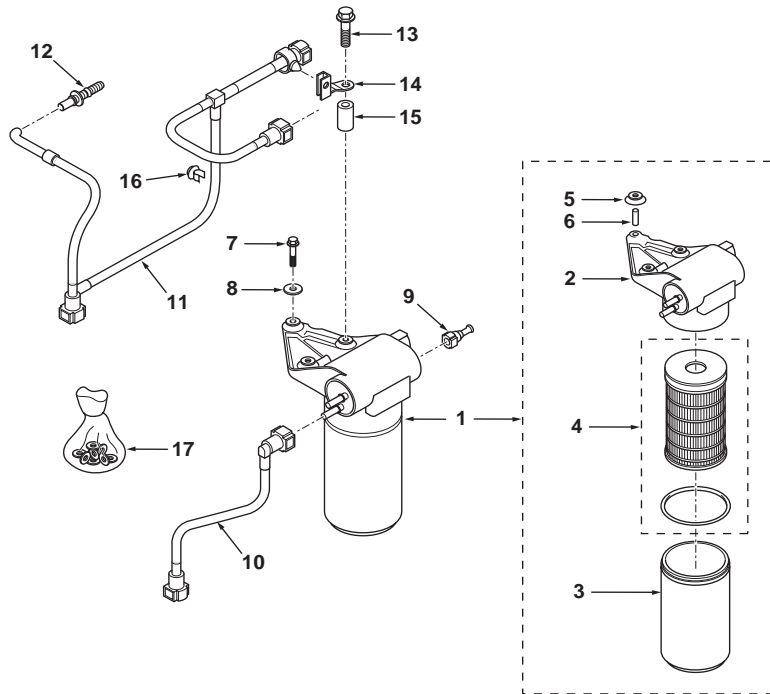

1	4132A008		1	Pump, Fuel Lift	Pompe à carburant	Bomba de combustible
2		1	▶ Ref. 1	Head	Tête	Cabeza
3		1	▶ Ref. 1	Base	Embase	Base
4	26560201	1		Element, Filter	Élément filtrant	Elemento filtrante
5		1 (A)		Mount	Support de fixation	Soporte de fijación
6		1 (A)		Spacer	Entretoise	Traviesa
7	2314F909	(A)		Screw	Vis	Tornillo
8	2131A507	(A)		Washer	Rondelle	Arandela
9	3763A046			Connector	Connecteur	Conector
10	2646F001			Pipe Assy	Ensemble tuyauterie	Tubo, Conj.
11	2646F002			Pipe Assy	Ensemble tuyauterie	Tubo, Conj.
12	3763A045			Connector	Connecteur	Conector
13	2314H008			Screw	Vis	Tornillo
14	3733A008			Bracket	Patte de fixation	Pata de fijación
15	3313A006			Spacer	Entretoise	Traviesa
16	2481D456			Clip	Clip	Clip
17	U5MK1017	(B)		Kit, Service	Kit d'entretien	Juego de servicio

A Included in kit marked (B)
Inclus dans jeu marqué (B)
Incluido en juego marcado (B)

B Contains items marked (A)
Comprend les pièces marquées (A)
Incluye las piezas marcadas (A)



820
TX760B

801 802 803 804 805 806 807 808 831 832 833 834

21010C19.1

6199042M3

1

Jan-06

Engine
Moteur
Motor

Fuel Lift Pump
Pompe d'alimentation de Carburant
Bomba de alimentación de carburante

RG38043
RG38043
RG38043

C-21011-19.1-A

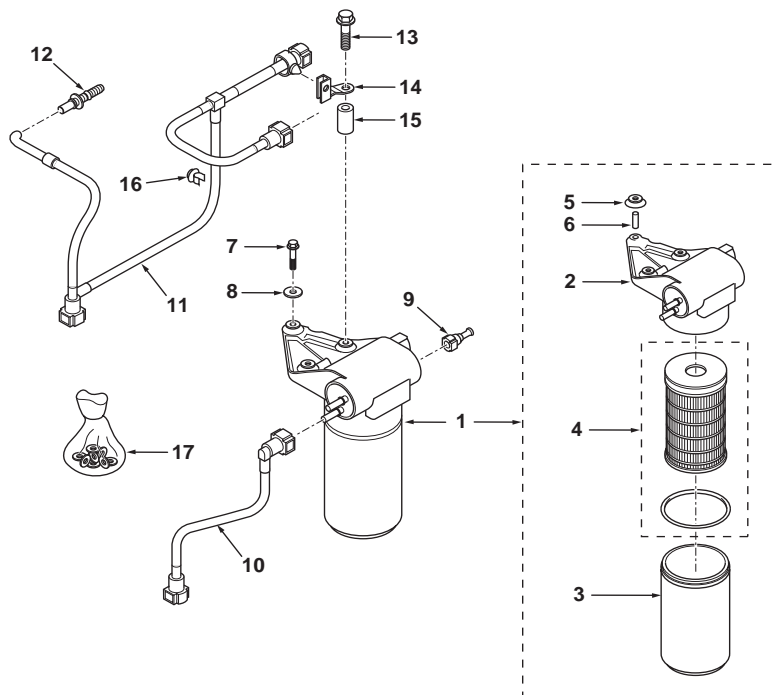

1	4132A008		1	Pump, Fuel Lift	Pompe à carburant	Bomba de combustible
2		1	▶ Ref. 1	Head	Tête	Cabeza
3		1	▶ Ref. 1	Base	Embase	Base
4	26560201	1		Element, Filter	Élément filtrant	Elemento filtrante
5		1 (A)		Mount	Support de fixation	Soporte de fijación
6		1 (A)		Spacer	Entretoise	Traviesa
7	2314F909	(A)		Screw	Vis	Tornillo
8	2131A507	(A)		Washer	Rondelle	Arandela
9	3763A046			Connector	Connecteur	Conector
10	2646F001			Pipe Assy	Ensemble tuyauterie	Tubo, Conj.
11	2646F002			Pipe Assy	Ensemble tuyauterie	Tubo, Conj.
12	3763A045			Connector	Connecteur	Conector
13	2314H008			Screw	Vis	Tornillo
14	3733A008			Bracket	Patte de fixation	Pata de fijación
15	3313A006			Spacer	Entretoise	Traviesa
16	2481D456			Clip	Clip	Clip
17	U5MK1017	(B)		Kit, Service	Kit d'entretien	Juego de servicio

A Included in kit marked (B)
Inclus dans jeu marqué (B)
Incluido en juego marcado (B)

B Contains items marked (A)
Comprend les pièces marquées (A)
Incluye las piezas marcadas (A)



820
TX760B

801 803 805 807 831 833

21011C19.1

6199042M3

1

Jan-06

Engine
Moteur
Motor

Fuel Lift Pump
Pompe d'alimentation de Carburant
Bomba de alimentación de carburante

RG38099
RG38099
RG38099

C-21012-19.1-A

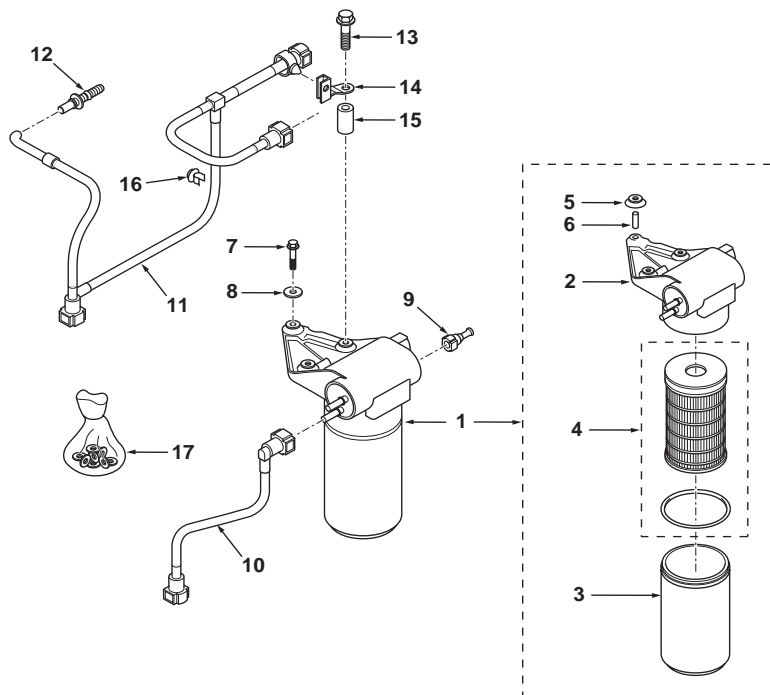

1	4132A008		1	Pump, Fuel Lift	Pompe à carburant	Bomba de combustible
2		1	➡ Ref. 1	Head	Tête	Cabeza
3		1	➡ Ref. 1	Base	Embase	Base
4	26560201	1		Element, Filter	Élément filtrant	Elemento filtrante
5		1 (A)		Mount	Support de fixation	Soporte de fijación
6		1 (A)		Spacer	Entretoise	Traviesa
7	2314F909	(A)		Screw	Vis	Tornillo
8	2131A507	(A)		Washer	Rondelle	Arandela
9	3763A046			Connector	Connecteur	Conector
10	2646F001			Pipe Assy	Ensemble tuyauterie	Tubo, Conj.
11	2646F002			Pipe Assy	Ensemble tuyauterie	Tubo, Conj.
12	3763A045			Connector	Connecteur	Conector
13	2314H008			Screw	Vis	Tornillo
14	3733A008			Bracket	Patte de fixation	Pata de fijación
15	3313A006			Spacer	Entretoise	Traviesa
16	2481D456			Clip	Clip	Clip
17	U5MK1017	(B)		Kit, Service	Kit d'entretien	Juego de servicio

A Included in kit marked (B)
Inclus dans jeu marqué (B)
Incluido en juego marcado (B)

B Contains items marked (A)
Comprend les pièces marquées (A)
Incluye las piezas marcadas (A)



860 880 970 980
TX860B TX870B
TX970B

809 810 811 812 813 814 815 816 817 821 822 823 824 825 841 842 843 844 845
851 852 853 854 855 921 922 923 931 932

Engine
Moteur
Motor

Fuel Lift Pump
Pompe d'alimentation de Carburant
Bomba de alimentación de carburante

RG38044
RG38044
RG38044

C-21013-19.1-A

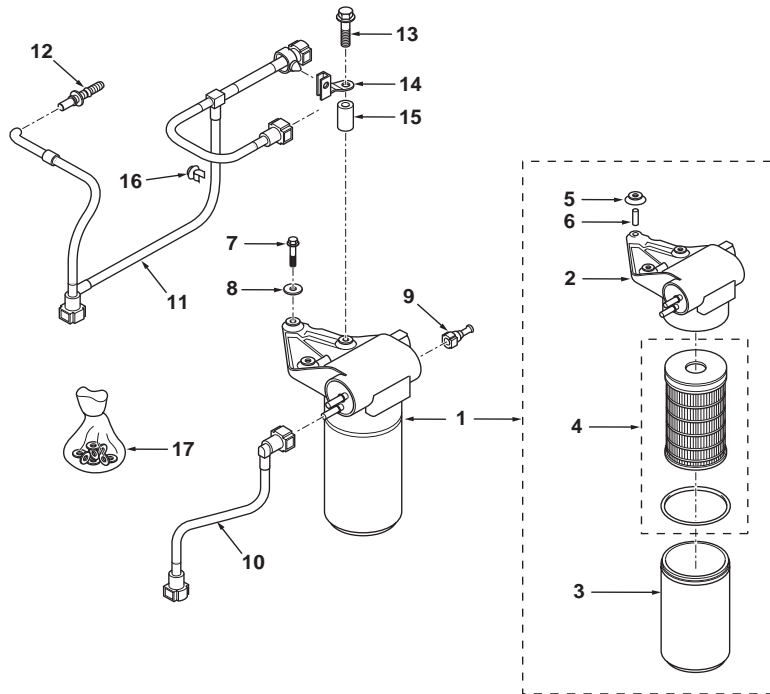

1	4132A008		1	Pump, Fuel Lift	Pompe à carburant	Bomba de combustible
2		1	➡ Ref. 1	Head	Tête	Cabeza
3		1	➡ Ref. 1	Base	Embase	Base
4	26560201	1		Element, Filter	Élément filtrant	Elemento filtrante
5		1 (A)		Mount	Support de fixation	Soporte de fijación
6		1 (A)		Spacer	Entretoise	Traviesa
7	2314F909	(A)		Screw	Vis	Tornillo
8	2131A507	(A)		Washer	Rondelle	Arandela
9	3763A046			Connector	Connecteur	Conector
10	2646F001			Pipe Assy	Ensemble tuyauterie	Tubo, Conj.
11	2646F002			Pipe Assy	Ensemble tuyauterie	Tubo, Conj.
12	3763A045			Connector	Connecteur	Conector
13	2314H008			Screw	Vis	Tornillo
14	3733A008			Bracket	Patte de fixation	Pata de fijación
15	3313A006			Spacer	Entretoise	Traviesa
16	2481D456			Clip	Clip	Clip
17	U5MK1017	(B)		Kit, Service	Kit d'entretien	Juego de servicio

A Included in kit marked (B)
Inclus dans jeu marqué (B)
Incluido en juego marcado (B)

B Contains items marked (A)
Comprend les pièces marquées (A)
Incluye las piezas marcadas (A)



860 880 970 980
TX860B TX870B
TX970B

809 811 813 815 817 821 823 825 841 843 845 851 853 855 921 922 923 931 932

21013C19.1

6199042M3

1

Jan-06

Engine
Moteur
Motor

Fuel System
Circuit Carburant
Circuito carburante

RG38100
RG38100
RG38100

C-21010-18.1-A

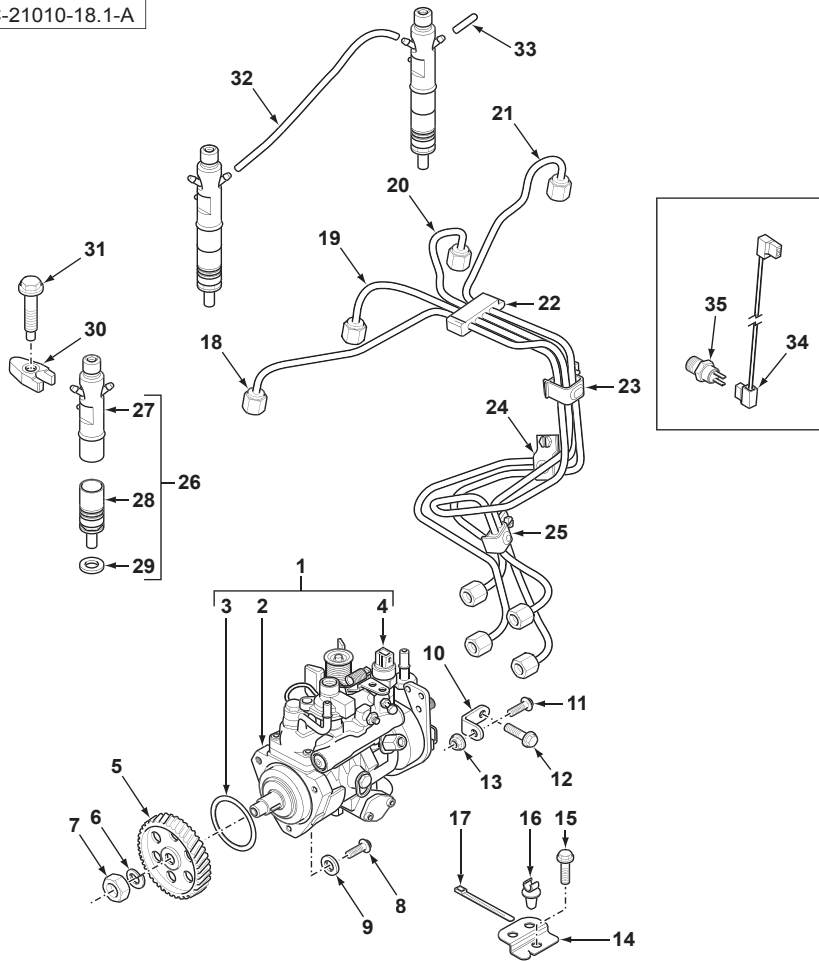

1	2644H002	(A)	1	Pump, Injection	Pompe d'injection	Bomba inyectora
2		1	1	Pump	Pompe	Bomba
3	26420318	1	1	O-Ring	Joint torique	Junta de tipo O
4	26420469	1	1	Solenoid	Solénoïde	Solenoid
NI	3161C012	1	1	Adaptor	Adaptateur	Adaptador
5	3117L261		1	Gear	Pignon	Piñón
6	K134AF01		1	Washer, Lock	Rondelle de blocage	Arandela de freno
7	2318A108		1	Nut	Écrou	Tuerca
8	2314H004	M8 x 25	3	Screw	Vis	Tornillo
9	2411D008		3	Washer	Rondelle	Arandela
10	3641A007		1	Bracket	Patte de fixation	Pata de fijación
11	2314H003	M8 x 20	1	Screw	Vis	Tornillo
12	2314J002	M10 x 20	1	Screw	Vis	Tornillo
13	2318A603	M8	1	Nut	Écrou	Tuerca
14	3651A016		1	Bracket	Patte de fixation	Pata de fijación
15	2314H002	M8 x 16	1	Screw	Vis	Tornillo
16	2481D556		1	Clip	Clip	Clip
17	2817154		1	Tie, Cable	Attache câble	Enlace de Cable
18	3525A101		1	Pipe Assy	Ensemble tuyauterie	Tubo, Conj.
19	3525A102		1	Pipe Assy	Ensemble tuyauterie	Tubo, Conj.
20	3525A103		1	Pipe Assy	Ensemble tuyauterie	Tubo, Conj.
21	3525A104		1	Pipe Assy	Ensemble tuyauterie	Tubo, Conj.
22	2646E019		1	Bracket, Clamp	Bride de fixation	Brida de fijación
23	2481Y012		1	Clip	Clip	Clip
24	2481Y011		1	Clip	Clip	Clip
25	2481D221		1	Clip	Clip	Clip
26	2645K011		4	Injector Assy	Ensemble d'injecteur	Inyector, Conj.
27		26	1	Holder	Porte-injecteur	Retén
28	2645K611	26	1	Nozzle	Gicleur d'injection	Surtidor de inyección
29	L311FF02	26	1	Washer	Rondelle	Arandela
30	3751A241		4	Clamp	Collier de serrage	Argolla de cierre
31	2314W009		4	Screw	Vis	Tornillo
32	2646F501		3	Hose	Flexible	Tubo flexible
33	2646E501		1	Cap	Chapeau	Sombbrero
34	3161C017		1	Cable	Câble	Cable
35	2848A127	(B)	1	Sender	Émetteur	Emisor

A Details to be advised
Détails à demander
Detalles que deben ser notificados

B Water temperature
Température de l'eau
Temperatura de agua



820
TX760B

801 802 803 804 805 806 807 808 831 832 833 834

21010C18.1

6199042M3

1

Jan-06

Engine
Moteur
Motor

Fuel System
Circuit Carburant
Circuito carburante

RG38043
RG38043
RG38043

C-21011-18.1-A

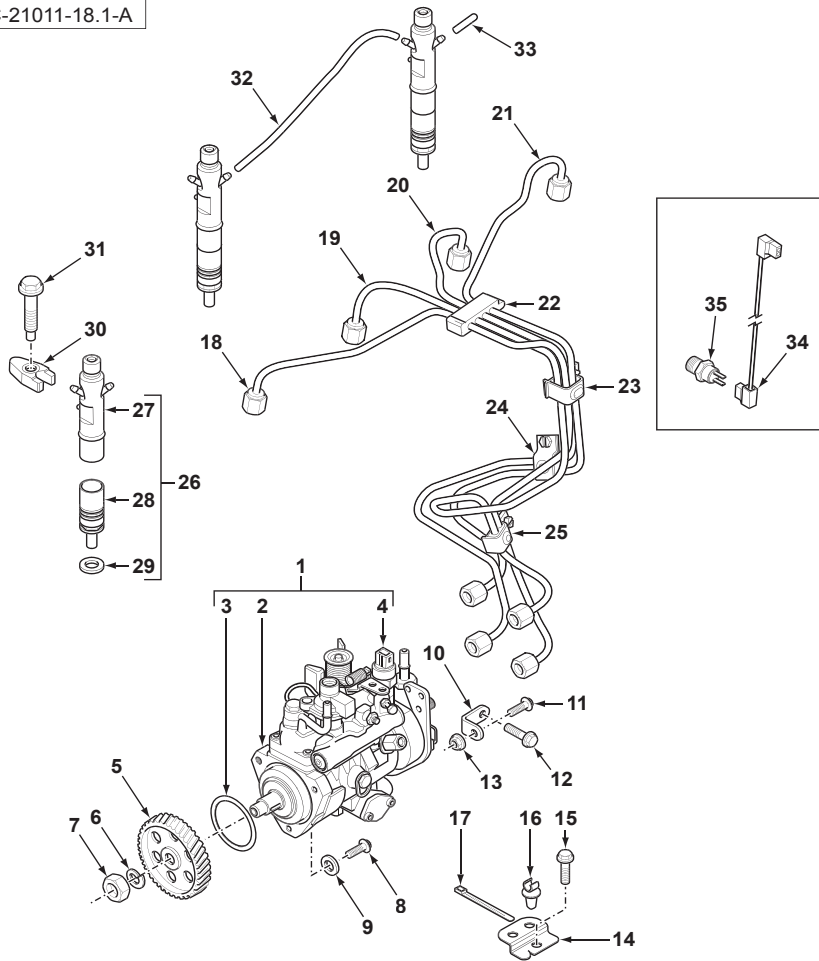

1	2644H002		(A)	1	Pump, Injection	Pompe d'injection	Bomba inyectora
2		1	➡ Ref. 1	1	Pump	Pompe	Bomba
3	26420318	1		1	O-Ring	Joint torique	Junta de tipo O
4	26420469	1		1	Solenoid	Solénoïde	Solenoid
NI	3161C012	1		1	Adaptor	Adaptateur	Adaptador
5	3117L261			1	Gear	Pignon	Piñón
6	K134AF01			1	Washer, Lock	Rondelle de blocage	Arandela de freno
7	2318A108			1	Nut	Écrou	Tuerca
8	2314H004	M8 x 25		3	Screw	Vis	Tornillo
9	2411D008			3	Washer	Rondelle	Arandela
10	3641A007			1	Bracket	Patte de fixation	Pata de fijación
11	2314H003	M8 x 20		1	Screw	Vis	Tornillo
12	2314J002	M10 x 20		1	Screw	Vis	Tornillo
13	2318A603	M8		1	Nut	Écrou	Tuerca
14	3651A016			1	Bracket	Patte de fixation	Pata de fijación
15	2314H002	M8 x 16		1	Screw	Vis	Tornillo
16	2481D556			1	Clip	Clip	Clip
17	2817154			1	Tie, Cable	Attache câble	Enlace de Cable
18	3525A101			1	Pipe Assy	Ensemble tuyauterie	Tubo, Conj.
19	3525A102			1	Pipe Assy	Ensemble tuyauterie	Tubo, Conj.
20	3525A103			1	Pipe Assy	Ensemble tuyauterie	Tubo, Conj.
21	3525A104			1	Pipe Assy	Ensemble tuyauterie	Tubo, Conj.
22	2646E019			1	Bracket, Clamp	Bride de fixation	Brida de fijación
23	2481Y012			1	Clip	Clip	Clip
24	2481Y011			1	Clip	Clip	Clip
25	2481D221			1	Clip	Clip	Clip
26	2645K011			4	Injector Assy	Ensemble d'injecteur	Inyector, Conj.
27		26	➡ Ref. 26	1	Holder	Porte-injecteur	Retén
28	2645K611	26		1	Nozzle	Gicleur d'injection	Surtidor de inyección
29	L311FF02	26		1	Washer	Rondelle	Arandela
30	3751A241			4	Clamp	Collier de serrage	Argolla de cierre
31	2314W009			4	Screw	Vis	Tornillo
32	2646F501			3	Hose	Flexible	Tubo flexible
33	2646E501			1	Cap	Chapeau	Sombbrero
34	3161C017			1	Cable	Câble	Cable
35	2848A127		(B)	1	Sender	Émetteur	Emisor

A Details to be advised
Détails à demander
Detalles que deben ser notificados

B Water temperature
Température de l'eau
Temperatura de agua



820
TX760B

801 803 805 807 831 833

21011C18.1

6199042M3

1

Jan-06

Engine
Moteur
Motor

Fuel System
Circuit Carburant
Circuito carburante

RG38099
RG38099
RG38099

C-21012 -18.1-A

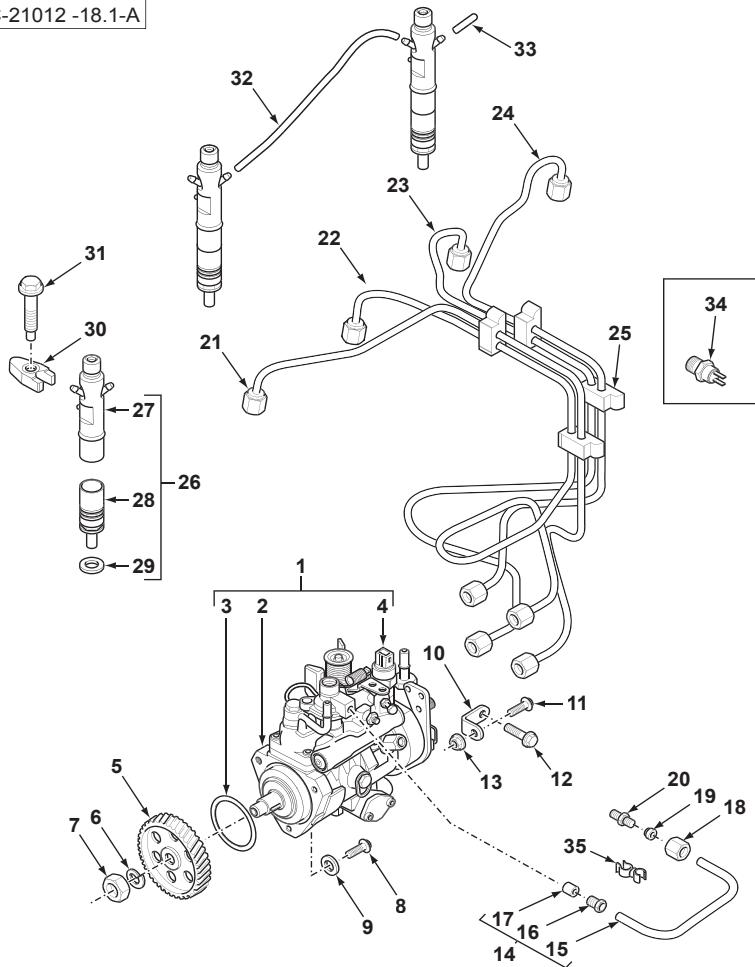

1	2644H003	(A)	1	Pump, Injection	Pompe d'injection	Bomba inyectora
2		1	1	Pump	Pompe	Bomba
3	26420318	1	1	O-Ring	Joint torique	Junta de tipo O
4	26420469	1	1	Solenoid	Solénoïde	Solenóide
5	3117L261		1	Gear	Pignon	Piñón
6	K134AF01		1	Washer, Lock	Rondelle de blocage	Arandela de freno
7	2318A108		1	Nut	Écrou	Tuerca
8	2314H004	M8 x 25	3	Screw	Vis	Tornillo
9	2411D008		3	Washer	Rondelle	Arandela
10	3641A007		1	Bracket	Patte de fixation	Pata de fijación
11	2314H003	M8 x 20	1	Screw	Vis	Tornillo
12	2314J002	M10 x 20	1	Screw	Vis	Tornillo
13	2318A603	M8	1	Nut	Écrou	Tuerca
14	4121A058		1	Pipe Assy	Ensemble tuyauterie	Tubo, Conj.
15		14	1	Pipe	Tuyau	Tubo
16	3353D004	14	1	Nut	Écrou	Tuerca
17	33811112	14	1	Orifice	Orifice	Orificio
18	0576111		1	Nut	Écrou	Tuerca
19	0566002		1	Orifice	Orifice	Orificio
20	0206002		1	Union	Union	Unión
21	3525A061		1	Pipe	Tuyau	Tubo
22	3525A062		1	Pipe	Tuyau	Tubo
23	3525A063		1	Pipe	Tuyau	Tubo
24	3525A064		1	Pipe	Tuyau	Tubo
25	2646E017		1	Bracket, Clamp	Bride de fixation	Brida de fijación
26	2645K011		4	Injector Assy	Ensemble d'injecteur	Inyector, Conj.
27		26	1	Holder	Porte-injecteur	Retén
28	2645K611	26	1	Nozzle	Gicleur d'injection	Surtidor de inyección
29	L311FF02	26	1	Washer	Rondelle	Arandela
30	3751A241		4	Clamp	Collier de serrage	Argolla de cierre
31	2314W009		4	Screw	Vis	Tornillo
32	2646F501		3	Hose	Flexible	Tubo flexible
33	2646E501		1	Cap	Chapeau	Sombbrero
34	2848A127	(B)	1	Sender	Émetteur	Emisor
35	K138AF02		1	Clip	Clip	Clip

A Details to be advised
Détails à demander
Detalles que deben ser notificados

B Water temperature
Température de l'eau
Temperatura de agua



860 880 970 980
TX860B TX870B
TX970B

809 810 811 812 813 814 815 816 817 821 822 823 824 825 841 842 843 844 845
851 852 853 854 855 921 922 923 931 932

21012C18.1

6199042M3

1

Jan-06

Engine
Moteur
Motor

Fuel System
Circuit Carburant
Circuito carburante

RG38044
RG38044
RG38044

C-21013 -18.1-A

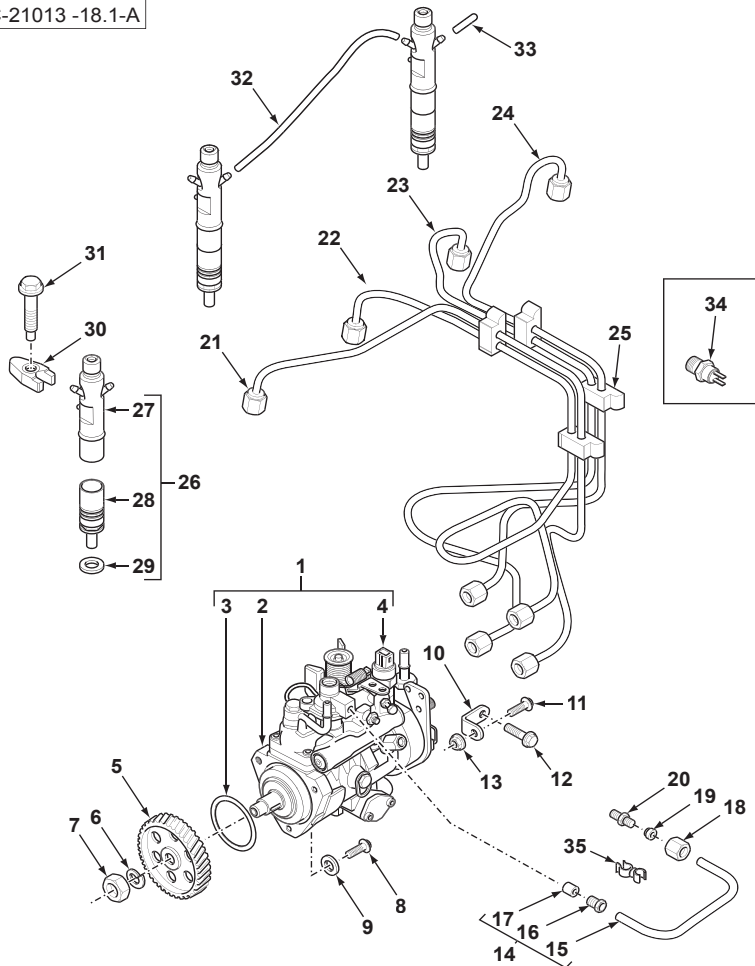

1	2644H003	(A)	1	Pump, Injection	Pompe d'injection	Bomba inyectora
2		1	1	Pump	Pompe	Bomba
3	26420318	1	1	O-Ring	Joint torique	Junta de tipo O
4	26420469	1	1	Solenoid	Solénoïde	Solenóide
5	3117L261		1	Gear	Pignon	Piñón
6	K134AF01		1	Washer, Lock	Rondelle de blocage	Arandela de freno
7	2318A108		1	Nut	Écrou	Tuerca
8	2314H004	M8 x 25	3	Screw	Vis	Tornillo
9	2411D008		3	Washer	Rondelle	Arandela
10	3641A007		1	Bracket	Patte de fixation	Pata de fijación
11	2314H003	M8 x 20	1	Screw	Vis	Tornillo
12	2314J002	M10 x 20	1	Screw	Vis	Tornillo
13	2318A603	M8	1	Nut	Écrou	Tuerca
14	4121A058		1	Pipe Assy	Ensemble tuyauterie	Tubo, Conj.
15		14	1	Pipe	Tuyau	Tubo
16	3353D004	14	1	Nut	Écrou	Tuerca
17	33811112	14	1	Orifice	Orifice	Orificio
18	0576111		1	Nut	Écrou	Tuerca
19	0566002		1	Orifice	Orifice	Orificio
20	0206002		1	Union	Union	Unión
21	3525A061		1	Pipe	Tuyau	Tubo
22	3525A062		1	Pipe	Tuyau	Tubo
23	3525A063		1	Pipe	Tuyau	Tubo
24	3525A064		1	Pipe	Tuyau	Tubo
25	2646E017		1	Bracket, Clamp	Bride de fixation	Brida de fijación
26	2645K011		4	Injector Assy	Ensemble d'injecteur	Inyector, Conj.
27		26	1	Holder	Porte-injecteur	Retén
28	2645K611	26	1	Nozzle	Gicleur d'injection	Surtidor de inyección
29	L311FF02	26	1	Washer	Rondelle	Arandela
30	3751A241		4	Clamp	Collier de serrage	Argolla de cierre
31	2314W009		4	Screw	Vis	Tornillo
32	2646F501		3	Hose	Flexible	Tubo flexible
33	2646E501		1	Cap	Chapeau	Sombbreroete
34	2848A127	(B)	1	Sender	Émetteur	Emisor
35	K138AF02		1	Clip	Clip	Clip

A Details to be advised
Détails à demander
Detalles que deben ser notificados

B Water temperature
Température de l'eau
Temperatura de agua



860 880 970 980
TX860B TX870B
TX970B

809 811 813 815 817 821 823 825 841 843 845 851 853 855 921 922 923 931 932

21013C18.1

6199042M3

1

Jan-06

Engine
Moteur Thermique
Motor térmico

Glow Plugs
Bougie réchauffage
Bujía, Calentamiento

RG38100
RG38100
RG38100

C-21010-22.1-A

1	2666A016		4	Plug, Glow	Bougie réchauffage	Bujía, Calentamiento
2	3161C015		1	Bar	Barre	Barra

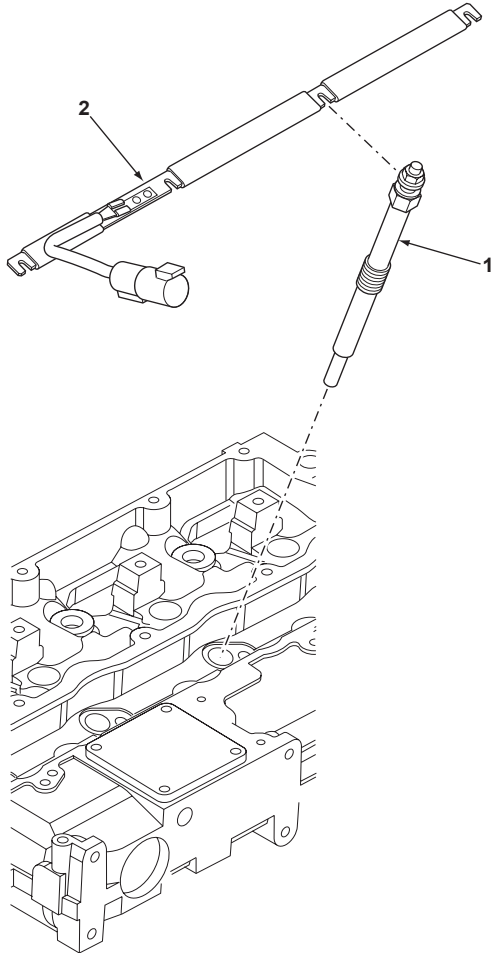

820
TX760B

801 802 803 804 805 806 807 808 831 832 833 834

Engine
Moteur Thermique
Motor térmico

Glow Plugs
Bougie réchauffage
Bujía, Calentamiento

RG38043
RG38043
RG38043

C-21011-22.1-A

1	2666A016		4	Plug, Glow	Bougie réchauffage	Bujía, Calentamiento
2	3161C015		1	Bar	Barre	Barra

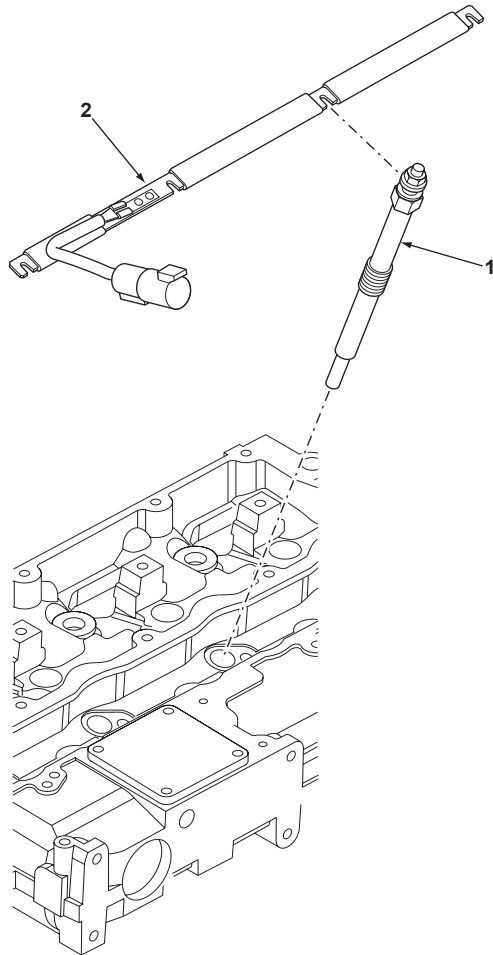

820
TX760B

801 803 805 807 831 833

21011C22.1

6199042M3

1

Jan-06

Engine
 Moteur Thermique
 Motor térmico

Glow Plugs
 Bougie réchauffage
 Bujía, Calentamiento

RG38099
 RG38099
 RG38099

C-21012-22.1-A

1	2666A016		4	Plug, Glow	Bougie réchauffage	Bujía, Calentamiento
2	3161C015		1	Bar	Barre	Barra

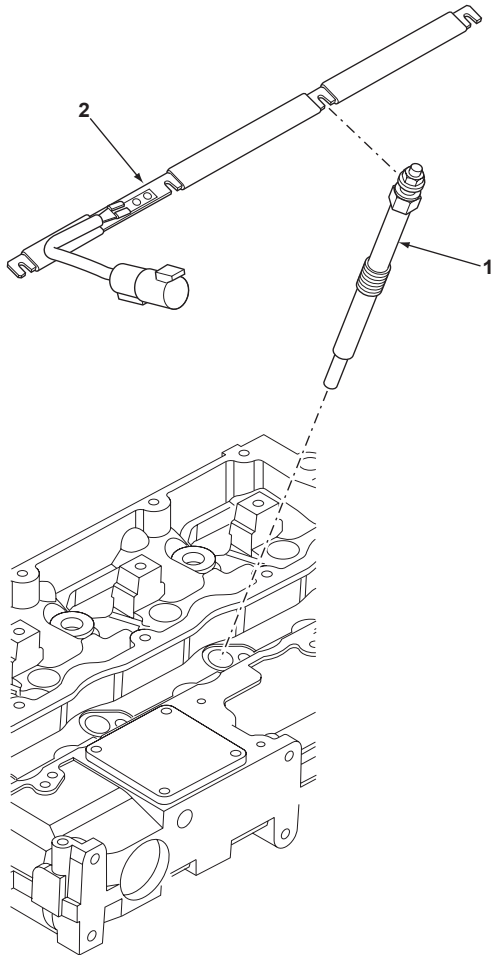

860 880 970 980
 TX860B TX870B
 TX970B

809 810 811 812 813 814 815 816 817 821 822 823 824 825 841 842 843 844 845
 851 852 853 854 855 921 922 923 931 932

Engine
Moteur Thermique
Motor térmico

Glow Plugs
Bougie réchauffage
Bujía, Calentamiento

RG38044
RG38044
RG38044

C-21013-22.1-A

1	2666A016		4	Plug, Glow	Bougie réchauffage	Bujía, Calentamiento
2	3161C015		1	Bar	Barre	Barra

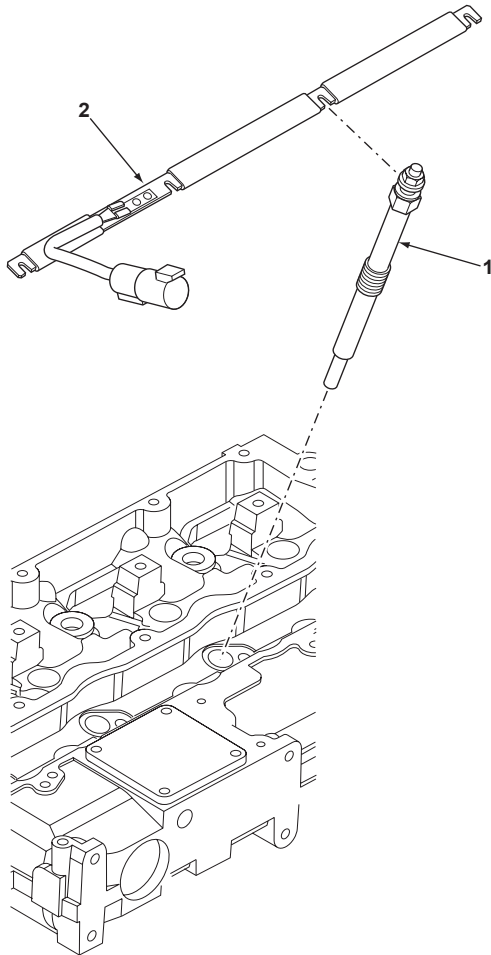

860 880 970 980
TX860B TX870B
TX970B

809 811 813 815 817 821 823 825 841 843 845 851 853 855 921 922 923 931 932

Engine
Moteur
Motor

Joints And Gaskets
Joints
Juntas

RG38100
RG38100
RG38100

C-21010-25.1-A

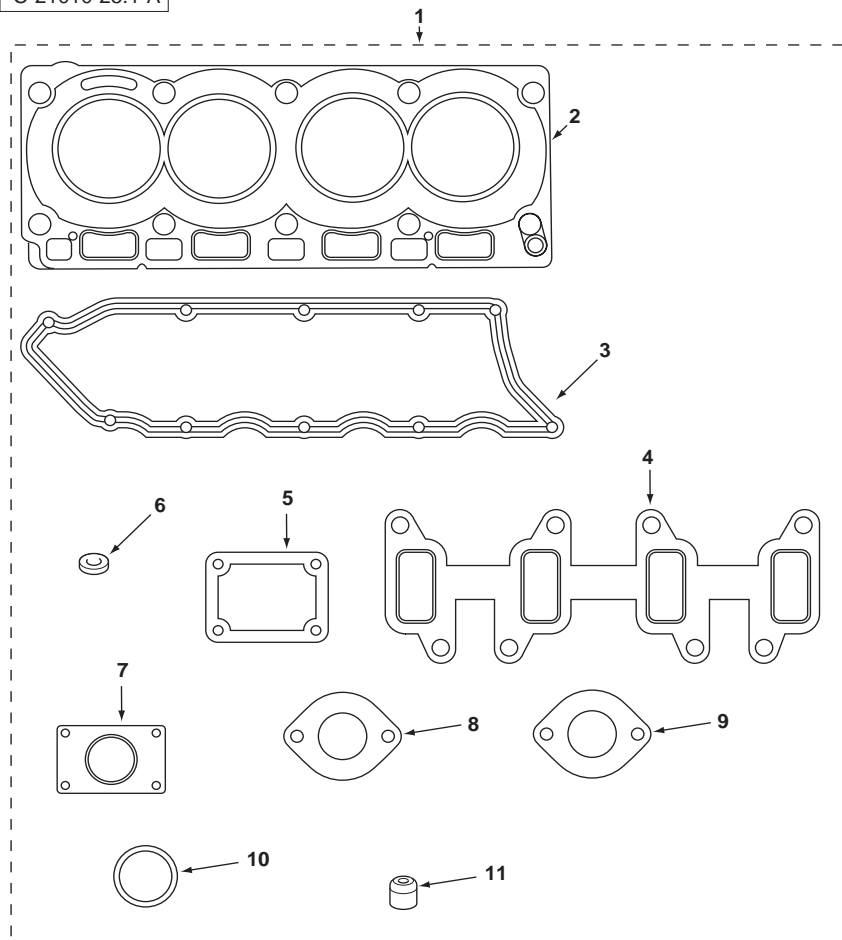

1	U5LT0350			1	Kit, Joint/Gasket	Jeu de joints	Juego juntas/empaq.
2	3681E046	1		1	Gasket, Cyl. Head	Joint de culasse	Junta de culata
3	3681A055	1		1	Joint	Articulation	Articulación
4	3681V512	1		1	Joint	Articulation	Articulación
5	3684N503	1		1	Seal	Joint	Junta
6	L311FF02	1	Injector	4	Washer	Rondelle	Arandela
7	3688A029	1		1	Joint	Articulation	Articulación
8	3688A035	1		1	Joint	Articulation	Articulación
9	3688A036	1		1	Joint	Articulation	Articulación
10	2415H008	1		1	O-Ring	Joint torique	Junta de tipo O
11	2418M514	1		8	Ring, Sealing	Bague d'étanchéité	Anillo, Estanqueidad



820
TX760B

801 802 803 804 805 806 807 808 831 832 833 834

21010C25.1

6199042M3

1

Jan-06

Engine
Moteur
Motor

Joints And Gaskets
Joints
Juntas

RG38100
RG38100
RG38100

Bottom
Bottom
Bottom

C-21010-26.1-A

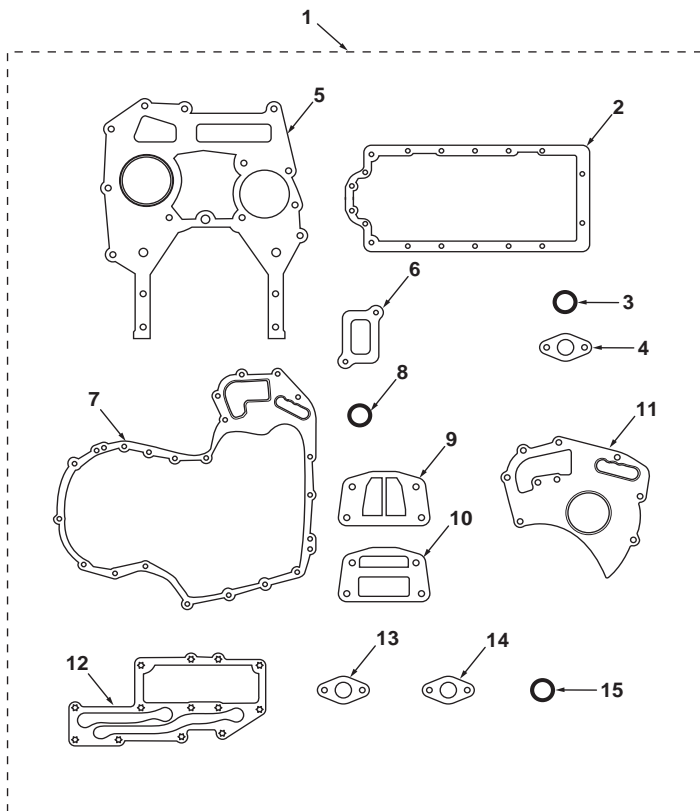

1	U5LB0376			1	Kit, Joint/Gasket	Jeu de joints	Juego juntas/empaq.
2	3681K037	1		1	Joint	Articulation	Articulación
3	2415715	1		1	O-Ring	Joint torique	Junta de tipo O
4	36832137	1		1	Joint	Articulation	Articulación
5	3617V015	1		1	Joint	Articulation	Articulación
6	3617V016	1		1	Joint	Articulation	Articulación
7	3681P046	1		1	Joint	Articulation	Articulación
8	26420318	1		1	O-Ring	Joint torique	Junta de tipo O
9	3688A041	1		1	Joint	Articulation	Articulación
10	3688A039	1		1	Joint	Articulation	Articulación
11	3682A011	1		1	Joint	Articulation	Articulación
12	3688A035	1		1	Joint	Articulation	Articulación
13	3685A024	1		1	Joint	Articulation	Articulación
14	3685A025	1		1	Seal	Joint	Junta
15	2415787	1		1	O-Ring	Joint torique	Junta de tipo O



820
TX760B

801 802 803 804 805 806 807 808 831 832 833 834

21010C26.1

6199042M3

1

Jan-06

Engine
Moteur
Motor

Joints And Gaskets
Joints
Juntas

RG38043
RG38043
RG38043

C-21011-25.1-A

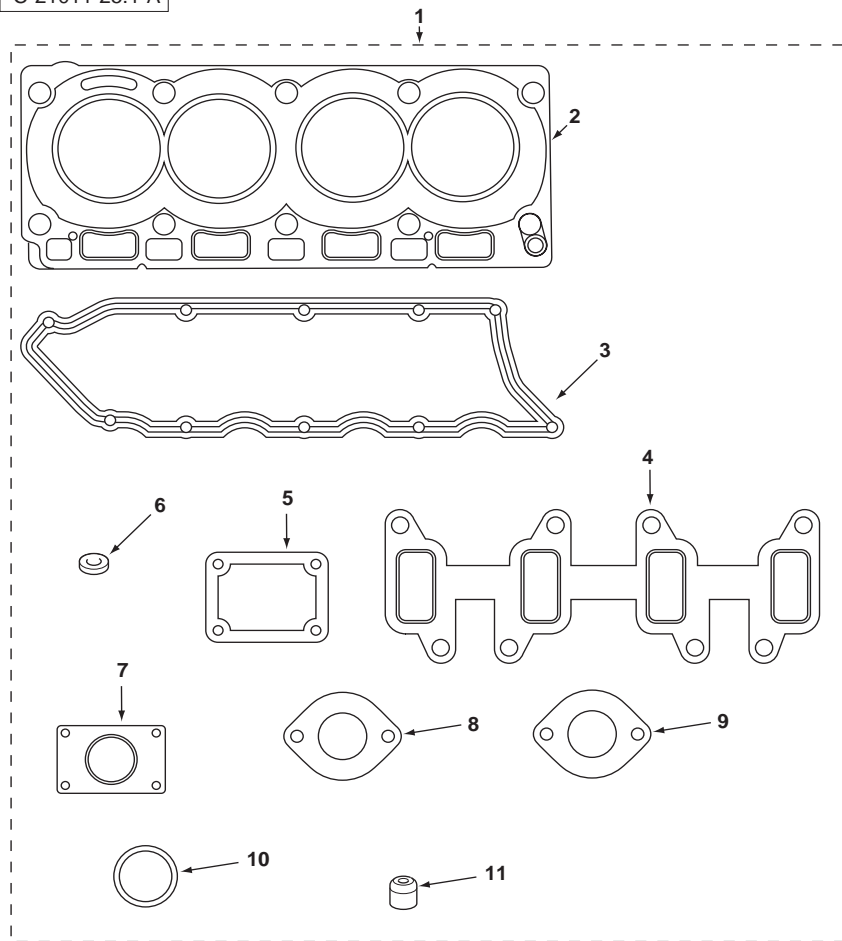

1	U5LT0350			1	Kit, Joint/Gasket	Jeu de joints	Juego juntas/empaq.
2	3681E046	1		1	Gasket, Cyl. Head	Joint de culasse	Junta de culata
3	3681A055	1		1	Joint	Articulation	Articulación
4	3681V512	1		1	Joint	Articulation	Articulación
5	3684N503	1		1	Seal	Joint	Junta
6	L311FF02	1	Injector	4	Washer	Rondelle	Arandela
7	3688A029	1		1	Joint	Articulation	Articulación
8	3688A035	1		1	Joint	Articulation	Articulación
9	3688A036	1		1	Joint	Articulation	Articulación
10	2415H008	1		1	O-Ring	Joint torique	Junta de tipo O
11	2418M514	1		8	Ring, Sealing	Bague d'étanchéité	Anillo, Estanqueidad



820
TX760B

801 803 805 807 831 833

21011C25.1

6199042M3

1

Jan-06

Engine
Moteur
Motor

Joints And Gaskets
Joints
Juntas

RG38043
RG38043
RG38043

Bottom
Bottom
Bottom

C-21011-26.1-A

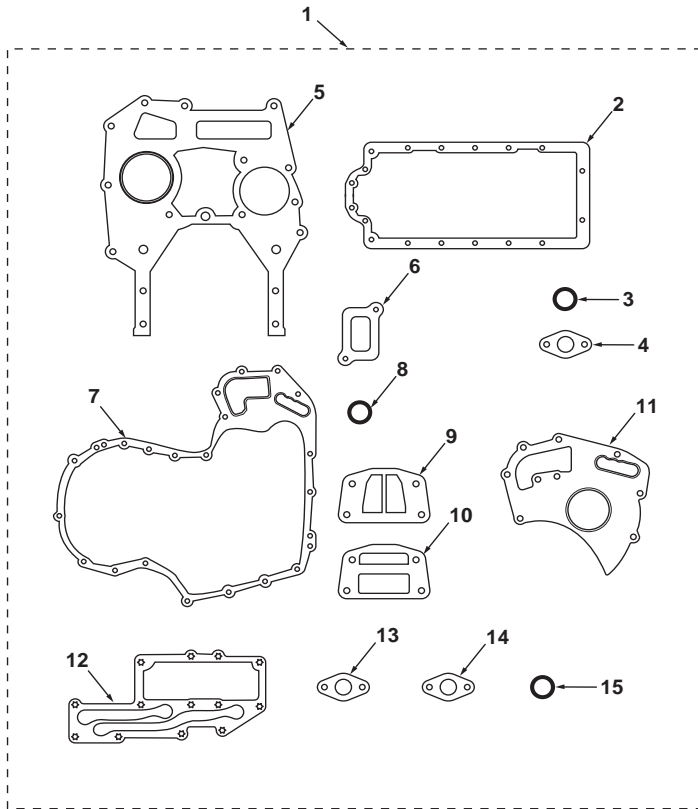

1	U5LB0376			1	Kit, Joint/Gasket	Jeu de joints	Juego juntas/empaq.
2	3681K037	1		1	Joint	Articulation	Articulación
3	2415715	1		1	O-Ring	Joint torique	Junta de tipo O
4	36832137	1		1	Joint	Articulation	Articulación
5	3617V015	1		1	Joint	Articulation	Articulación
6	3617V016	1		1	Joint	Articulation	Articulación
7	3681P046	1		1	Joint	Articulation	Articulación
8	26420318	1		1	O-Ring	Joint torique	Junta de tipo O
9	3688A041	1		1	Joint	Articulation	Articulación
10	3688A039	1		1	Joint	Articulation	Articulación
11	3682A011	1		1	Joint	Articulation	Articulación
12	3688A035	1		1	Joint	Articulation	Articulación
13	3685A024	1		1	Joint	Articulation	Articulación
14	3685A025	1		1	Seal	Joint	Junta
15	2415787	1		1	O-Ring	Joint torique	Junta de tipo O



820
TX760B

801 803 805 807 831 833

21011C26.1

6199042M3

1

Jan-06

Engine
Moteur
Motor

Joints And Gaskets
Joints
Juntas

RG38099
RG38099
RG38099

C-21012-25.1-A

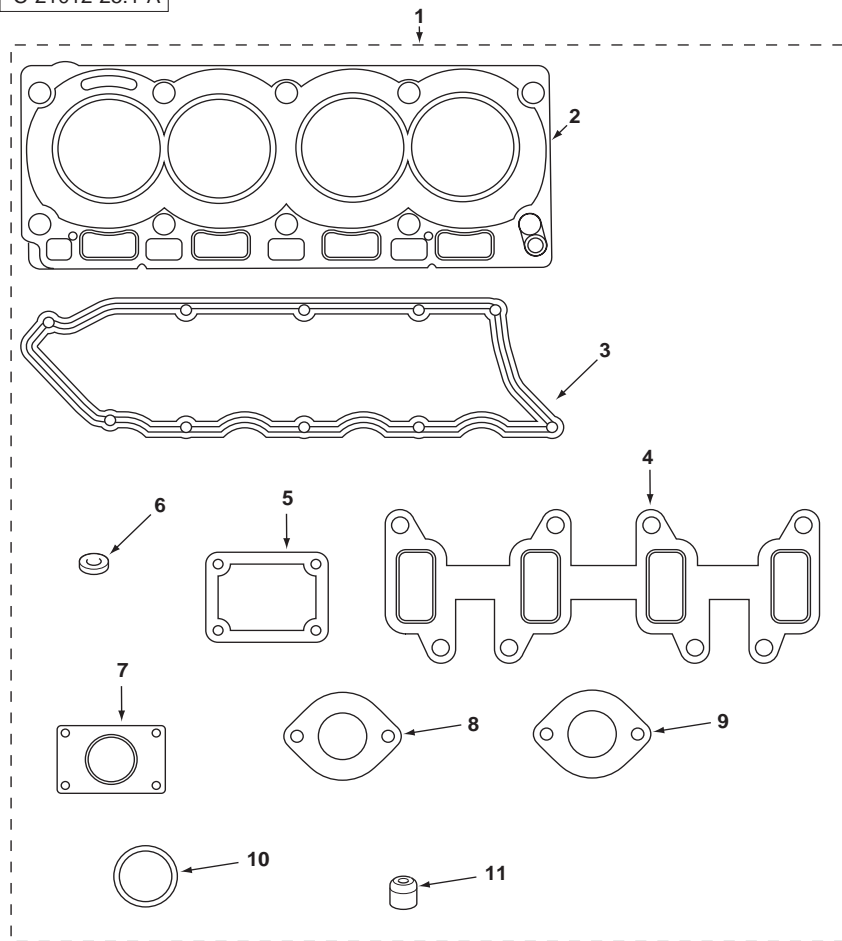

1	U5LT0350			1	Kit, Joint/Gasket	Jeu de joints	Juego juntas/empaq.
2	3681E046	1		1	Gasket, Cyl. Head	Joint de culasse	Junta de culata
3	3681A055	1		1	Joint	Articulation	Articulación
4	3681V512	1		1	Joint	Articulation	Articulación
5	3684N503	1		1	Seal	Joint	Junta
6	L311FF02	1	Injector	4	Washer	Rondelle	Arandela
7	3688A029	1		1	Joint	Articulation	Articulación
8	3688A035	1		1	Joint	Articulation	Articulación
9	3688A036	1		1	Joint	Articulation	Articulación
10	2415H008	1		1	O-Ring	Joint torique	Junta de tipo O
11	2418M514	1		8	Ring, Sealing	Bague d'étanchéité	Anillo, Estanqueidad



860 880 970 980
TX860B TX870B
TX970B

809 810 811 812 813 814 815 816 817 821 822 823 824 825 841 842 843 844 845
851 852 853 854 855 921 922 923 931 932

21012C25.1

6199042M3

1

Jan-06

Engine
Moteur
Motor

Joints And Gaskets
Joints
Juntas

RG38099
RG38099
RG38099

Bottom
Bottom
Bottom

C-21012-26.1-A

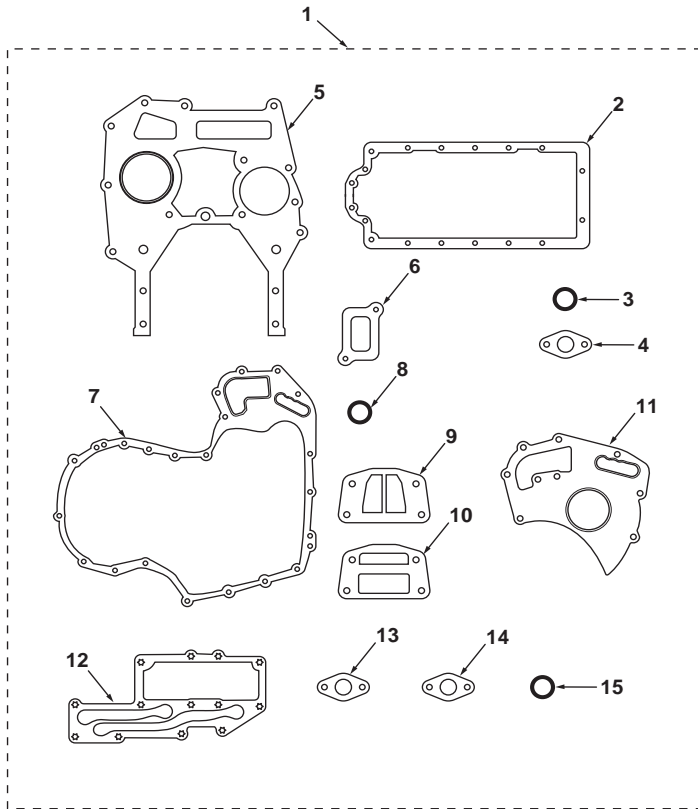

1	U5LB0376			1	Kit, Joint/Gasket	Jeu de joints	Juego juntas/empaq.
2	3681K037	1		1	Joint	Articulation	Articulación
3	2415715	1		1	O-Ring	Joint torique	Junta de tipo O
4	36832137	1		1	Joint	Articulation	Articulación
5	3617V015	1		1	Joint	Articulation	Articulación
6	3617V016	1		1	Joint	Articulation	Articulación
7	3681P046	1		1	Joint	Articulation	Articulación
8	26420318	1		1	O-Ring	Joint torique	Junta de tipo O
9	3688A041	1		1	Joint	Articulation	Articulación
10	3688A039	1		1	Joint	Articulation	Articulación
11	3682A011	1		1	Joint	Articulation	Articulación
12	3688A035	1		1	Joint	Articulation	Articulación
13	3685A024	1		1	Joint	Articulation	Articulación
14	3685A025	1		1	Seal	Joint	Junta
15	2415787	1		1	O-Ring	Joint torique	Junta de tipo O



860 880 970 980
TX860B TX870B
TX970B

809 810 811 812 813 814 815 816 817 821 822 823 824 825 841 842 843 844 845
851 852 853 854 855 921 922 923 931 932

21012C26.1

6199042M3

1

Jan-06

Engine
Moteur
Motor

Joints And Gaskets
Joints
Juntas

RG38044
RG38044
RG38044

C-21013-25.1-A

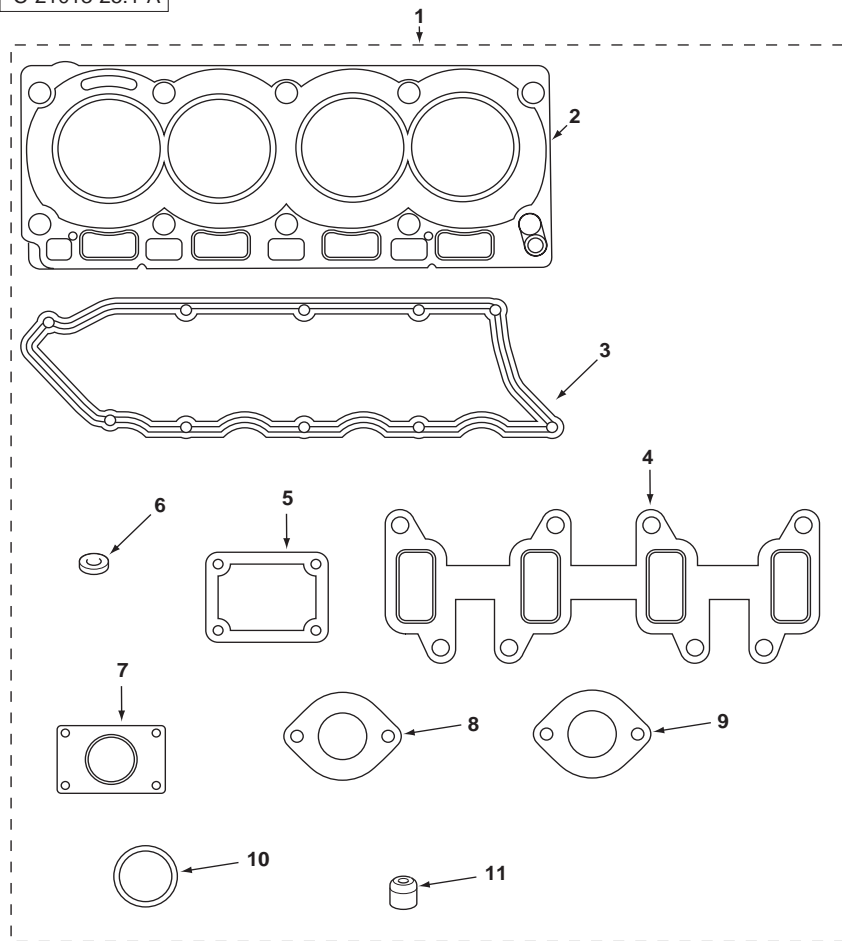

1	U5LT0350			1	Kit, Joint/Gasket	Jeu de joints	Juego juntas/empaq.
2	3681E046	1		1	Gasket, Cyl. Head	Joint de culasse	Junta de culata
3	3681A055	1		1	Joint	Articulation	Articulación
4	3681V512	1		1	Joint	Articulation	Articulación
5	3684N503	1		1	Seal	Joint	Junta
6	L311FF02	1	Injector	4	Washer	Rondelle	Arandela
7	3688A029	1		1	Joint	Articulation	Articulación
8	3688A035	1		1	Joint	Articulation	Articulación
9	3688A036	1		1	Joint	Articulation	Articulación
10	2415H008	1		1	O-Ring	Joint torique	Junta de tipo O
11	2418M514	1		8	Ring, Sealing	Bague d'étanchéité	Anillo, Estanqueidad



860 880 970 980
TX860B TX870B
TX970B

809 811 813 815 817 821 823 825 841 843 845 851 853 855 921 922 923 931 932

21013C25.1

6199042M3

1

Jan-06

Engine
Moteur
Motor

Joints And Gaskets
Joints
Juntas

RG38044
RG38044
RG38044

Bottom
Bottom
Bottom

C-21013-26.1-A

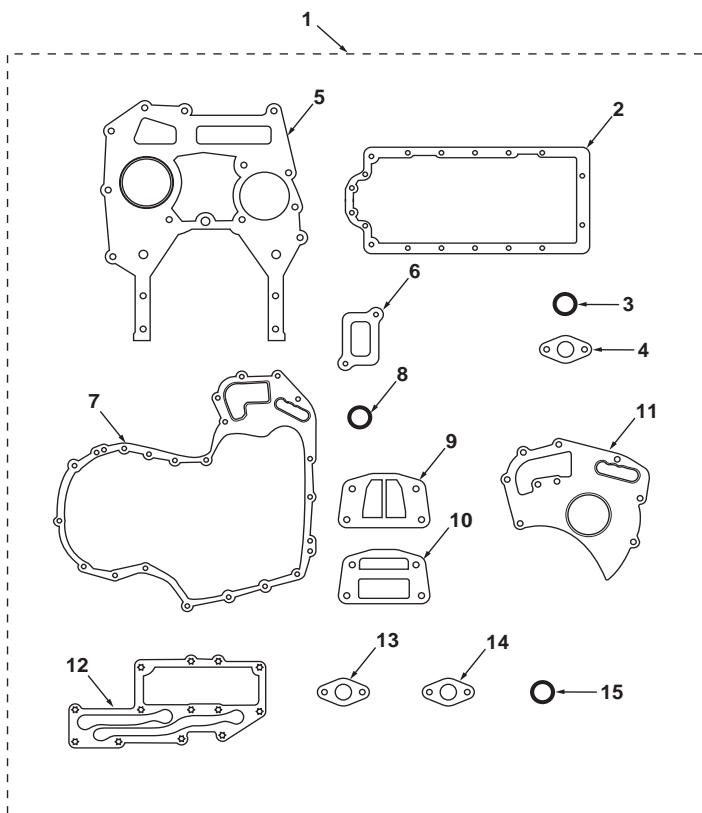

1	U5LB0376			1	Kit, Joint/Gasket	Jeu de joints	Juego juntas/empaq.
2	3681K037	1		1	Joint	Articulation	Articulación
3	2415715	1		1	O-Ring	Joint torique	Junta de tipo O
4	36832137	1		1	Joint	Articulation	Articulación
5	3617V015	1		1	Joint	Articulation	Articulación
6	3617V016	1		1	Joint	Articulation	Articulación
7	3681P046	1		1	Joint	Articulation	Articulación
8	26420318	1		1	O-Ring	Joint torique	Junta de tipo O
9	3688A041	1		1	Joint	Articulation	Articulación
10	3688A039	1		1	Joint	Articulation	Articulación
11	3682A011	1		1	Joint	Articulation	Articulación
12	3688A035	1		1	Joint	Articulation	Articulación
13	3685A024	1		1	Joint	Articulation	Articulación
14	3685A025	1		1	Seal	Joint	Junta
15	2415787	1		1	O-Ring	Joint torique	Junta de tipo O



860 880 970 980
TX860B TX870B
TX970B

809 811 813 815 817 821 823 825 841 843 845 851 853 855 921 922 923 931 932

21013C26.1

6199042M3

1

Jan-06

Engine
Moteur
Motor

Lubricating Oil Filler And Breather
Remplisseur d'huile et Reniflard
Respiradero y tubo de llenado del aceite
lubricante

RG38100
RG38100
RG38100

C-21010-07.1-A

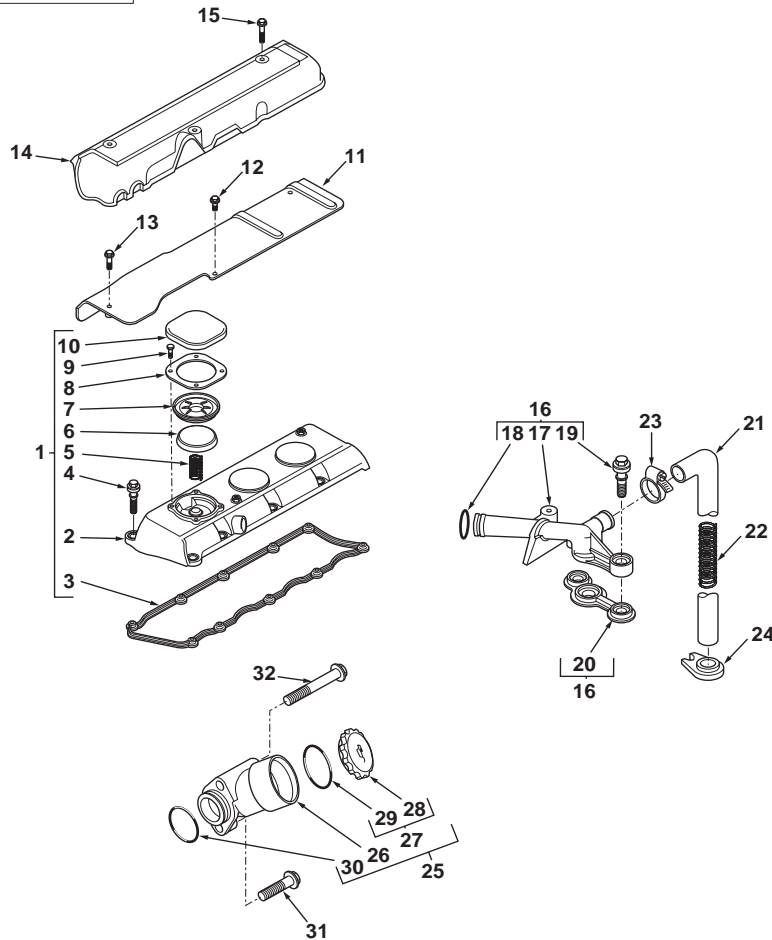

1	4142X294			1	Cover Assy	Ensemble de couvercle	Tapa, Conj.
2		1	➡ Ref. 1	1	Cover	Cache	Tapa
3	3681A055	1		1	Joint	Articulation	Articulación
4	2161A011	1		10	Screw	Vis	Tornillo
5	3174A017	1		1	Spring	Ressort	Muelle
6	3788A002	1		1	Cap	Chapeau	Sombreroete
7	3789A001	1		1	Diaphragm	Diaphragme	Diafragma
8	3615A009	1		1	Plate, Cover	Plaque de fermeture	Placa de cierre
9	2151A001	1		4	Screw	Vis	Tornillo
10	3788A003	1		1	Cap	Chapeau	Sombreroete
11	3812A026			1	Heatshield	Garant thermique	Pantalla térmica
12	2314F001			2	Screw	Vis	Tornillo
13	2314F006			1	Screw	Vis	Tornillo
14	3788N005			1	Cover	Cache	Tapa
15	2314F005			3	Screw	Vis	Tornillo
16	4134K015			1	Breather Assy	Ensemble de reniflard	Ventil. cárter, Conj.
17		16	➡ Ref. 16	1	Breather	Reniflard	Ventilador del cárter
18	2415A068	16		1	O-Ring	Joint torique	Junta de tipo O
19	2161A011	16		2	Screw	Vis	Tornillo
20	3688A038	16		1	Joint	Articulation	Articulación
21	33872632			1	Hose	Flexible	Tubo flexible
22	3175P003			1	Spring	Ressort	Muelle
23	2481877			1	Clamp	Collier de serrage	Argolla de cierre
24	36241123			1	Bracket	Patte de fixation	Pata de fijación
25	4134C043			1	Filler	Remplisseur	Rellenador
26		25	➡ Ref. 25	1	Filler	Remplisseur	Rellenador
27	4142X098	25		1	Cap Assy	Ensemble de cache	Tapa, Conj.
28		27	➡ Ref. 27	1	Cap	Chapeau	Sombreroete
29	2415633	27		1	O-Ring	Joint torique	Junta de tipo O
30	2415B148	25		1	O-Ring	Joint torique	Junta de tipo O
31	2314H005		M8 x 30	1	Screw	Vis	Tornillo
32	2314K161		M8 x 60	1	Screw	Vis	Tornillo



820
TX760B

801 802 803 804 805 806 807 808 831 832 833 834

21010C07.1

6199042M3

1

Jan-06

Engine
Moteur
Motor

Lubricating Oil Filler And Breather
Remplisseur d'huile et Reniflard
Respiradero y tubo de llenado del aceite
lubricante

RG38043
RG38043
RG38043

C-21011-07.1-A

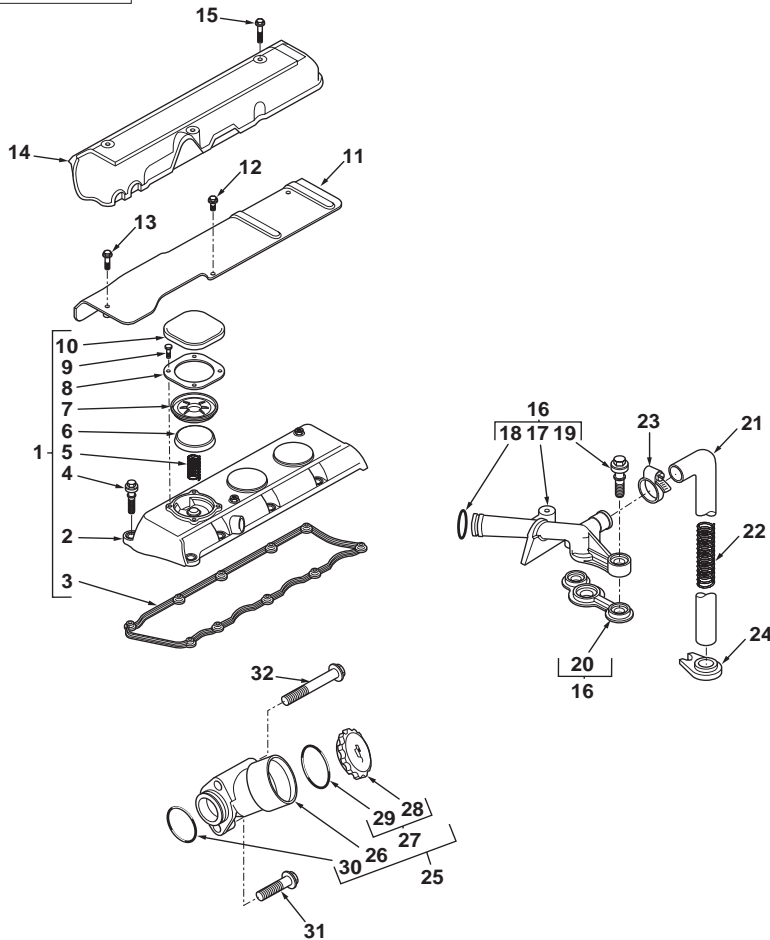

1	4142X294			1	Cover Assy	Ensemble de couvercle	Tapa, Conj.
2		1	➡ Ref. 1	1	Cover	Cache	Tapa
3	3681A055	1		1	Joint	Articulation	Articulación
4	2161A011	1		10	Screw	Vis	Tornillo
5	3174A017	1		1	Spring	Ressort	Muelle
6	3788A002	1		1	Cap	Chapeau	Sombreroete
7	3789A001	1		1	Diaphragm	Diaphragme	Diafragma
8	3615A009	1		1	Plate, Cover	Plaque de fermeture	Placa de cierre
9	2151A001	1		4	Screw	Vis	Tornillo
10	3788A003	1		1	Cap	Chapeau	Sombreroete
11	3812A026			1	Heatshield	Garant thermique	Pantalla térmica
12	2314F001			2	Screw	Vis	Tornillo
13	2314F006			1	Screw	Vis	Tornillo
14	3788N005			1	Cover	Cache	Tapa
15	2314F005			3	Screw	Vis	Tornillo
16	4134K015			1	Breather Assy	Ensemble de reniflard	Ventil. cárter, Conj.
17		16	➡ Ref. 16	1	Breather	Reniflard	Ventilador del cárter
18	2415A068	16		1	O-Ring	Joint torique	Junta de tipo O
19	2161A011	16		2	Screw	Vis	Tornillo
20	3688A038	16		1	Joint	Articulation	Articulación
21	33872632			1	Hose	Flexible	Tubo flexible
22	3175P003			1	Spring	Ressort	Muelle
23	2481877			1	Clamp	Collier de serrage	Argolla de cierre
24	36241123			1	Bracket	Patte de fixation	Pata de fijación
25	4134C043			1	Filler	Remplisseur	Rellenador
26		25	➡ Ref. 25	1	Filler	Remplisseur	Rellenador
27	4142X098	25		1	Cap Assy	Ensemble de cache	Tapa, Conj.
28		27	➡ Ref. 27	1	Cap	Chapeau	Sombreroete
29	2415633	27		1	O-Ring	Joint torique	Junta de tipo O
30	2415B148	25		1	O-Ring	Joint torique	Junta de tipo O
31	2314H005		M8 x 30	1	Screw	Vis	Tornillo
32	2314K161		M8 x 60	1	Screw	Vis	Tornillo



820
TX760B

801 803 805 807 831 833

21011C07.1

6199042M3

1

Jan-06

Engine
Moteur
Motor

Lubricating Oil Filler And Breather
Remplisseur d'huile et Reniflard
Respiradero y tubo de llenado del aceite
lubricante

RG38099
RG38099
RG38099

C-21012-07.1-A

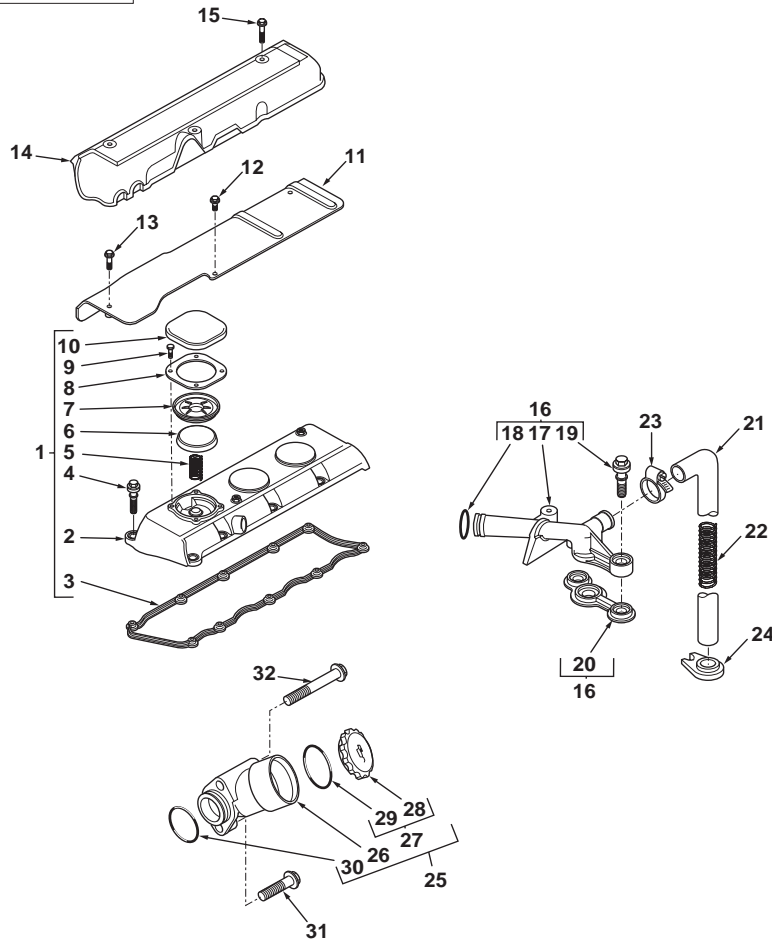

1	4142X294			1	Cover Assy	Ensemble de couvercle	Tapa, Conj.
2		1	➡ Ref. 1	1	Cover	Cache	Tapa
3	3681A055	1		1	Joint	Articulation	Articulación
4	2161A011	1		10	Screw	Vis	Tornillo
5	3174A017	1		1	Spring	Ressort	Muelle
6	3788A002	1		1	Cap	Chapeau	Sombreroete
7	3789A001	1		1	Diaphragm	Diaphragme	Diafragma
8	3615A009	1		1	Plate, Cover	Plaque de fermeture	Placa de cierre
9	2151A001	1		4	Screw	Vis	Tornillo
10	3788A003	1		1	Cap	Chapeau	Sombreroete
11	3812A026			1	Heatshield	Garant thermique	Pantalla térmica
12	2314F001			2	Screw	Vis	Tornillo
13	2314F006			1	Screw	Vis	Tornillo
14	3788N005			1	Cover	Cache	Tapa
15	2314F005			3	Screw	Vis	Tornillo
16	4134K015			1	Breather Assy	Ensemble de reniflard	Ventil. cárter, Conj.
17		16	➡ Ref. 16	1	Breather	Reniflard	Ventilador del cárter
18	2415A068	16		1	O-Ring	Joint torique	Junta de tipo O
19	2161A011	16		2	Screw	Vis	Tornillo
20	3688A038	16		1	Joint	Articulation	Articulación
21	33872632			1	Hose	Flexible	Tubo flexible
22	3175P003			1	Spring	Ressort	Muelle
23	2481877			1	Clamp	Collier de serrage	Argolla de cierre
24	36241123			1	Bracket	Patte de fixation	Pata de fijación
25	4134C043			1	Filler	Remplisseur	Rellenador
26		25	➡ Ref. 25	1	Filler	Remplisseur	Rellenador
27	4142X098	25		1	Cap Assy	Ensemble de cache	Tapa, Conj.
28		27	➡ Ref. 27	1	Cap	Chapeau	Sombreroete
29	2415633	27		1	O-Ring	Joint torique	Junta de tipo O
30	2415B148	25		1	O-Ring	Joint torique	Junta de tipo O
31	2314H005		M8 x 30	1	Screw	Vis	Tornillo
32	2314K161		M8 x 60	1	Screw	Vis	Tornillo



860 880 970 980
TX860B TX870B
TX970B

809 810 811 812 813 814 815 816 817 821 822 823 824 825 841 842 843 844 845
851 852 853 854 855 921 922 923 931 932

21012C07.1

6199042M3

1

Jan-06

Engine
Moteur
Motor

Lubricating Oil Filler And Breather
Remplisseur d'huile et Reniflard
Respiradero y tubo de llenado del aceite
lubricante

RG38044
RG38044
RG38044

C-21013-07.1-A

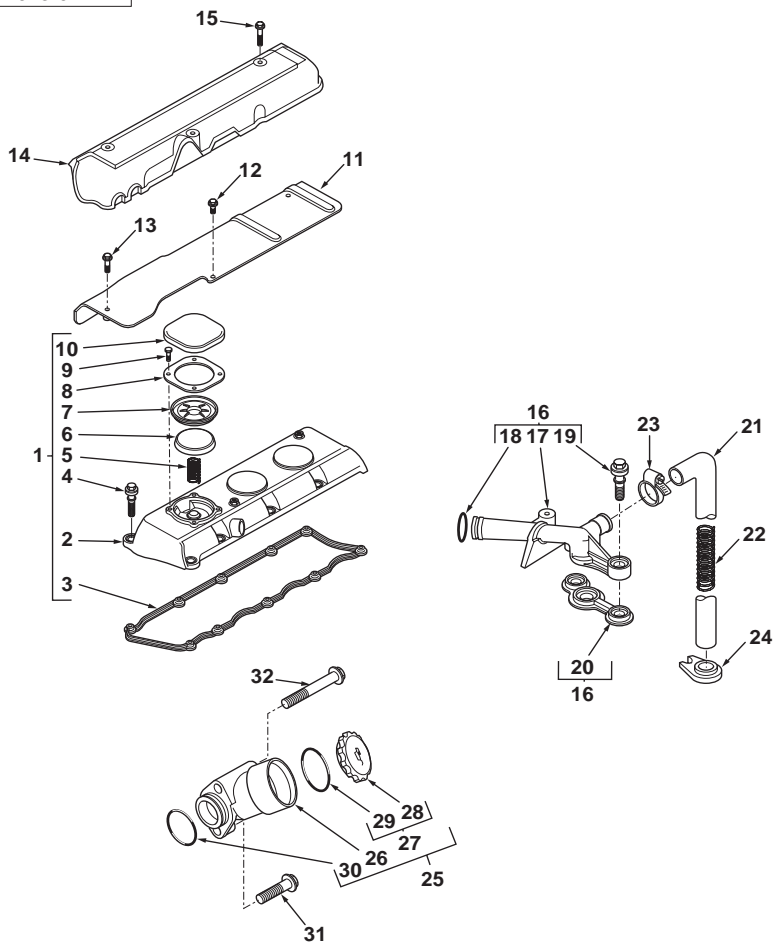

1	4142X294			1	Cover Assy	Ensemble de couvercle	Tapa, Conj.
2		1	➡ Ref. 1	1	Cover	Cache	Tapa
3	3681A055	1		1	Joint	Articulation	Articulación
4	2161A011	1		10	Screw	Vis	Tornillo
5	3174A017	1		1	Spring	Ressort	Muelle
6	3788A002	1		1	Cap	Chapeau	Sombreroete
7	3789A001	1		1	Diaphragm	Diaphragme	Diafragma
8	3615A009	1		1	Plate, Cover	Plaque de fermeture	Placa de cierre
9	2151A001	1		4	Screw	Vis	Tornillo
10	3788A003	1		1	Cap	Chapeau	Sombreroete
11	3812A026			1	Heatshield	Garant thermique	Pantalla térmica
12	2314F001			2	Screw	Vis	Tornillo
13	2314F006			1	Screw	Vis	Tornillo
14	3788N005			1	Cover	Cache	Tapa
15	2314F005			3	Screw	Vis	Tornillo
16	4134K015			1	Breather Assy	Ensemble de reniflard	Ventil. cárter, Conj.
17		16	➡ Ref. 16	1	Breather	Reniflard	Ventilador del cárter
18	2415A068	16		1	O-Ring	Joint torique	Junta de tipo O
19	2161A011	16		2	Screw	Vis	Tornillo
20	3688A038	16		1	Joint	Articulation	Articulación
21	33872632			1	Hose	Flexible	Tubo flexible
22	3175P003			1	Spring	Ressort	Muelle
23	2481877			1	Clamp	Collier de serrage	Argolla de cierre
24	36241123			1	Bracket	Patte de fixation	Pata de fijación
25	4134C043			1	Filler	Remplisseur	Rellenador
26		25	➡ Ref. 25	1	Filler	Remplisseur	Rellenador
27	4142X098	25		1	Cap Assy	Ensemble de cache	Tapa, Conj.
28		27	➡ Ref. 27	1	Cap	Chapeau	Sombreroete
29	2415633	27		1	O-Ring	Joint torique	Junta de tipo O
30	2415B148	25		1	O-Ring	Joint torique	Junta de tipo O
31	2314H005	M8 x 30		1	Screw	Vis	Tornillo
32	2314K161	M8 x 60		1	Screw	Vis	Tornillo



860 880 970 980
TX860B TX870B
TX970B

809 811 813 815 817 821 823 825 841 843 845 851 853 855 921 922 923 931 932

21013C07.1

6199042M3

1

Jan-06

Engine
Moteur
Motor

Lubricating Oil Filter And Integral Oil
Cooler
Filtre à Huile et Refroidisseur d'huile
Filtro y enfriador integral de aceite

RG38100
RG38100
RG38100

C-21010-16.1-A

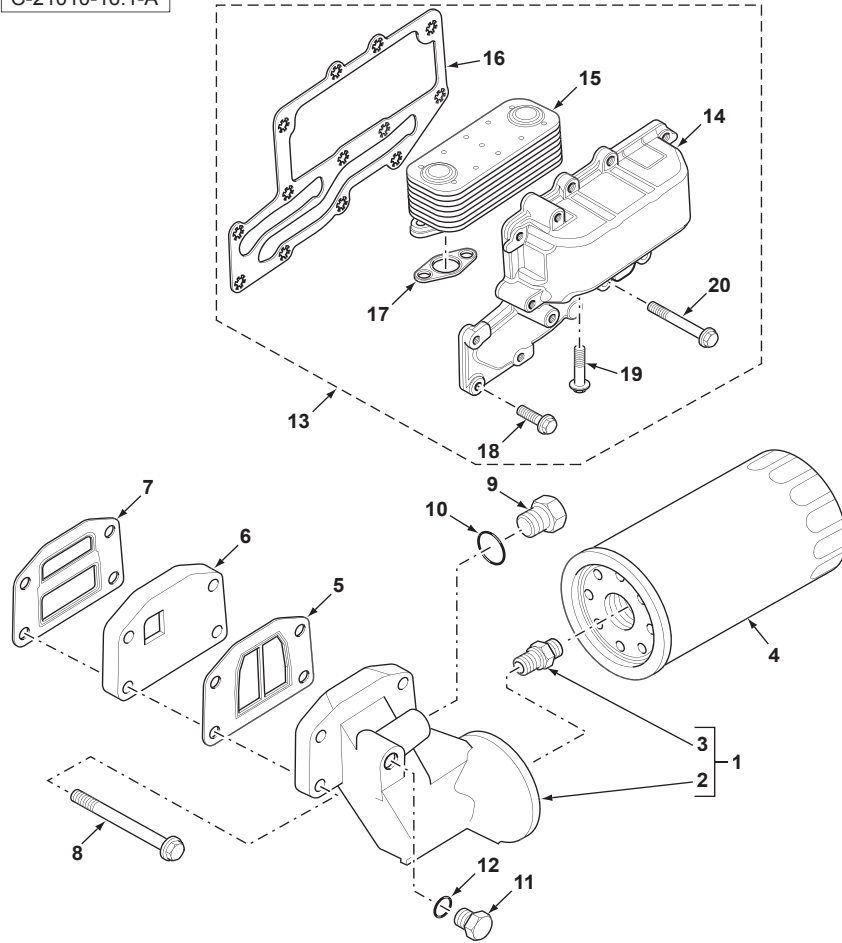

1	4134E057			1	Head Assy	Ensemble de tête	Cabeza, Conj.
2		1	➡ Ref. 1	1	Head	Tête	Cabeza
3	33554128	1		1	Fitting	Raccord	Racor
4	2654407			1	Filter, Oil	Filtre à huile	Filtro de aceite
5	3688A041			1	Joint	Articulation	Articulación
6	3773A081			1	Adaptor	Adaptateur	Adaptador
7	3688A039			1	Joint	Articulation	Articulación
8	2314H038			4	Screw	Vis	Tornillo
9	3278A004			1	Plug	Bouchon	Tapón
10	2415H002			1	O-Ring	Joint torique	Junta de tipo O
11	3278A007			1	Plug	Bouchon	Tapón
12	2415H009			1	O-Ring	Joint torique	Junta de tipo O
13	4134W001			1	Cooler Assy, Oil	Ensemble huile refr.	Aceite conjunto enfr.
14		13	➡ Ref. 13	1	Body	Corps	Cuerpo
15	2486A217	13		1	Cooler, Oil	Refroidisseur d'huile	Radiador de aceite
16	3685A024	13		1	Joint	Articulation	Articulación
17	3685A025	13		2	Seal	Joint	Junta
18	2314H004	13	M8 x 25	10	Screw	Vis	Tornillo
19	2314H006	13	M8 x 35	4	Screw	Vis	Tornillo
20	2314K161	13	M8 x 60	3	Screw	Vis	Tornillo



820
TX760B

801 802 803 804 805 806 807 808 831 832 833 834

21010C16.1

6199042M3

1

Jan-06

Engine
Moteur
Motor

Lubricating Oil Filter And Integral Oil
Cooler
Filtre à Huile et Refroidisseur d'huile
Filtro y enfriador integral de aceite

RG38043
RG38043
RG38043

C-21011-16.1-A

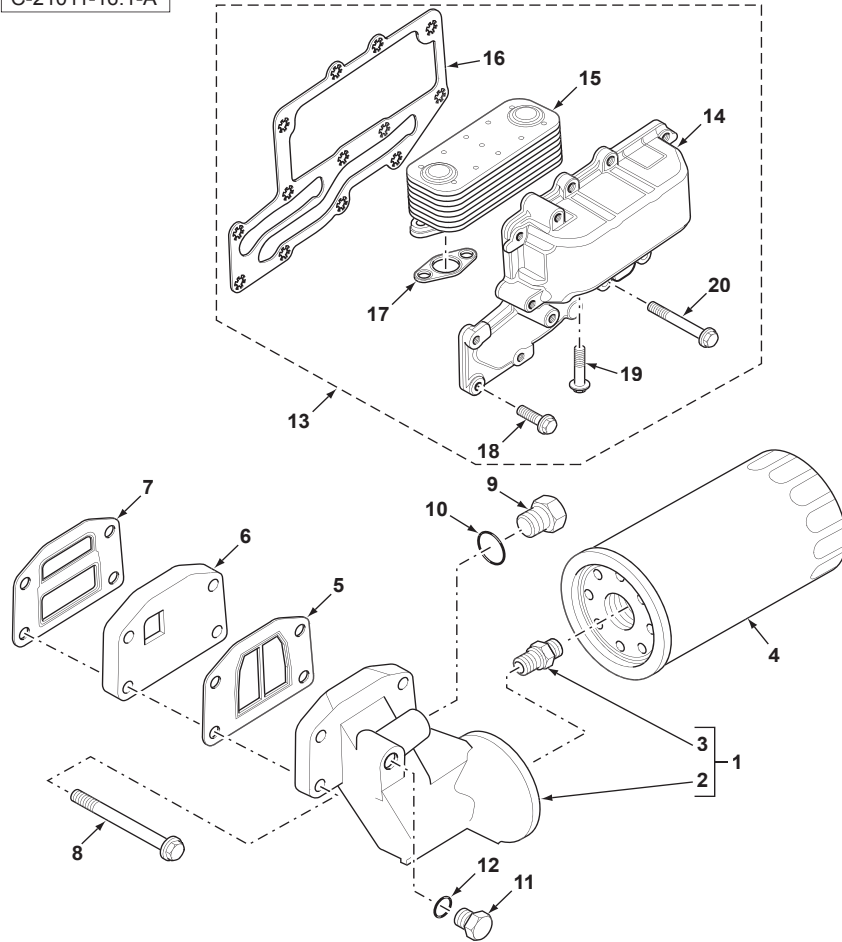

1	4134E057			1	Head Assy	Ensemble de tête	Cabeza, Conj.
2		1	➡ Ref. 1	1	Head	Tête	Cabeza
3	33554128	1		1	Fitting, Oil	Raccord	Racor
4	2654407			1	Filter, Oil	Filtre à huile	Filtro de aceite
5	3688A041			1	Joint	Articulation	Articulación
6	3773A081			1	Adaptor	Adaptateur	Adaptador
7	3688A039			1	Joint	Articulation	Articulación
8	2314H038			4	Screw	Vis	Tornillo
9	3278A004			1	Plug	Bouchon	Tapón
10	2415H002			1	O-Ring	Joint torique	Junta de tipo O
11	3278A007			1	Plug	Bouchon	Tapón
12	2415H009			1	O-Ring	Joint torique	Junta de tipo O
13	4134W001			1	Cooler Assy, Oil	Ensemble huile refr.	Aceite conjunto enfr.
14		13	➡ Ref. 13	1	Body	Corps	Cuerpo
15	2486A217	13		1	Cooler, Oil	Refroidisseur d'huile	Radiador de aceite
16	3685A024	13		1	Joint	Articulation	Articulación
17	3685A025	13		2	Seal	Joint	Junta
18	2314H004	13	M8 x 25	10	Screw	Vis	Tornillo
19	2314H006	13	M8 x 35	4	Screw	Vis	Tornillo
20	2314K161	13	M8 x 60	3	Screw	Vis	Tornillo



820
TX760B

801 803 805 807 831 833

21011C16.1

6199042M3

1

Jan-06

Engine
Moteur
Motor

Lubricating Oil Filter And Integral Oil
Cooler
Filtre à Huile et Refroidisseur d'huile
Filtro y enfriador integral de aceite

RG38099
RG38099
RG38099

C-21012-16.1-A

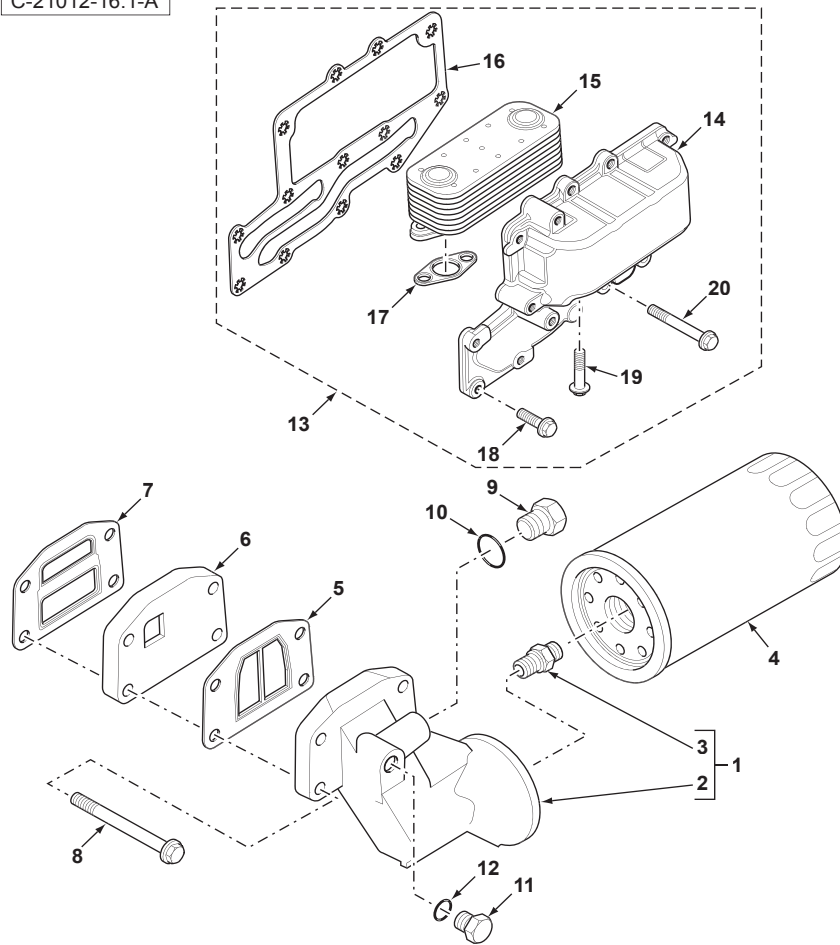

1	4134E057			1	Head Assy	Ensemble de tête	Cabeza, Conj.
2		1	➡ Ref. 1	1	Head	Tête	Cabeza
3	33554128	1		1	Fitting	Raccord	Racor
4	2654407			1	Filter, Oil	Filtre à huile	Filtro de aceite
5	3688A041			1	Joint	Articulation	Articulación
6	3773A081			1	Adaptor	Adaptateur	Adaptador
7	3688A039			1	Joint	Articulation	Articulación
8	2314H038			4	Screw	Vis	Tornillo
9	3278A004			1	Plug	Bouchon	Tapón
10	2415H002			1	O-Ring	Joint torique	Junta de tipo O
11	3278A007			1	Plug	Bouchon	Tapón
12	2415H009			1	O-Ring	Joint torique	Junta de tipo O
13	4134W001			1	Cooler Assy, Oil	Ensemble huile refr.	Aceite conjunto enfr.
14		13	➡ Ref. 13	1	Body	Corps	Cuerpo
15	2486A217	13		1	Cooler, Oil	Refroidisseur d'huile	Radiador de aceite
16	3685A024	13		1	Joint	Articulation	Articulación
17	3685A025	13		2	Seal	Joint	Junta
18	2314H004	13	M8 x 25	10	Screw	Vis	Tornillo
19	2314H006	13	M8 x 35	4	Screw	Vis	Tornillo
20	2314K161	13	M8 x 60	3	Screw	Vis	Tornillo



860 880 970 980
TX860B TX870B
TX970B

809 810 811 812 813 814 815 816 817 821 822 823 824 825 841 842 843 844 845
851 852 853 854 855 921 922 923 931 932

21012C16.1

6199042M3

1

Jan-06

Engine
Moteur
Motor

Lubricating Oil Filter And Integral Oil
Cooler
Filtre à Huile et Refroidisseur d'huile
Filtro y enfriador integral de aceite

RG38044
RG38044
RG38044

C-21013-16.1-A

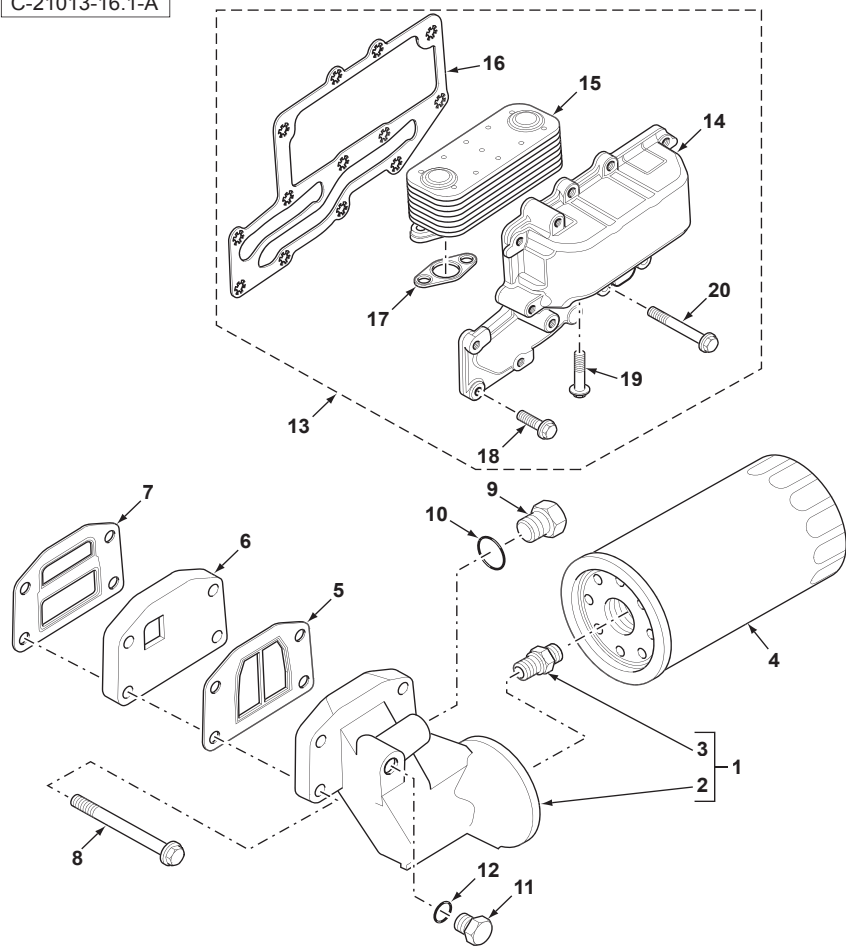

1	4134E057			1	Head Assy	Ensemble de tête	Cabeza, Conj.
2		1	➔ Ref. 1	1	Head	Tête	Cabeza
3	33554128	1		1	Fitting	Raccord	Racor
4	2654407			1	Filter, Oil	Filtre à huile	Filtro de aceite
5	3688A041			1	Joint	Articulation	Articulación
6	3773A081			1	Adaptor	Adaptateur	Adaptador
7	3688A039			1	Joint	Articulation	Articulación
8	2314H038			4	Screw	Vis	Tornillo
9	3278A004			1	Plug	Bouchon	Tapón
10	2415H002			1	O-Ring	Joint torique	Junta de tipo O
11	3278A007			1	Plug	Bouchon	Tapón
12	2415H009			1	O-Ring	Joint torique	Junta de tipo O
13	4134W001			1	Cooler Assy, Oil	Ensemble huile refr.	Aceite conjunto enfr.
14		13	➔ Ref. 13	1	Body	Corps	Cuerpo
15	2486A217	13		1	Cooler, Oil	Refroidisseur d'huile	Radiador de aceite
16	3685A024	13		1	Joint	Articulation	Articulación
17	3685A025	13		2	Seal	Joint	Junta
18	2314H004	13	M8 x 25	10	Screw	Vis	Tornillo
19	2314H006	13	M8 x 35	4	Screw	Vis	Tornillo
20	2314K161	13	M8 x 60	3	Screw	Vis	Tornillo



860 880 970 980
TX860B TX870B
TX970B

809 811 813 815 817 821 823 825 841 843 845 851 853 855 921 922 923 931 932

21013C16.1

6199042M3

1

Jan-06

Engine
Moteur
Motor

Oil Pan
Carter d'huile
Cárter de aceite

RG38100
RG38100
RG38100

C-21010-15.1-A

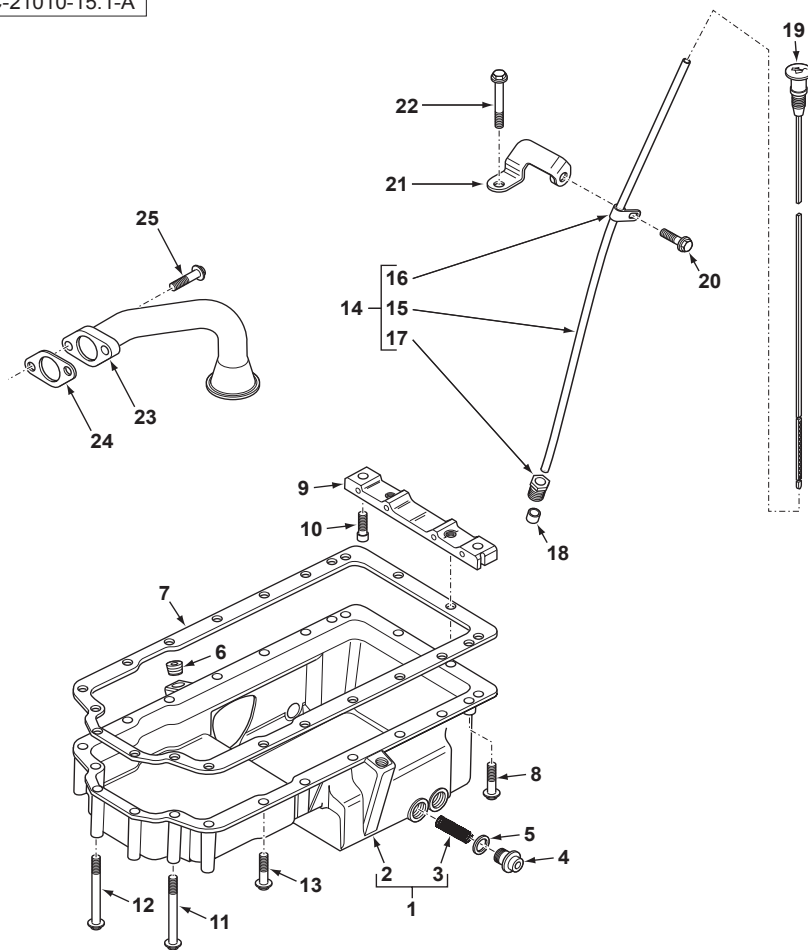

1	4145H091		1	Pan, Oil	Carter à huile	Cárter de aceite
2		1	▶ Ref. 1	Pan, Oil	Carter à huile	Cárter de aceite
3	2137435	1		Spring	Ressort	Muelle
4	32186405			Plug	Bouchon	Tapón
5	2415715			O-Ring	Joint torique	Junta de tipo O
6	2431A016			Plug	Bouchon	Tapón
7	3681K037			Joint	Articulation	Articulación
8	2314H033			Screw	Vis	Tornillo
9	3627P041			Plate	Plaque	Placa
10	2311D039			Screw	Vis	Tornillo
11	2314K166			Screw	Vis	Tornillo
12	2314K166			Screw	Vis	Tornillo
13	2314H003	M8 x 20		Screw	Vis	Tornillo
14	4126A081			Tube Assy	Tuyauterie	Conjunto de tubería
15		14	▶ Ref. 14	Tube	Tube	Tubo
16	0180170	14		Clip, Mounting	Collier de fixation	Argolla de fijación
17	3353D005	14		Nut	Écrou	Tuerca
18	33812116			Orifice	Orifice	Orificio
19	3178C169			Dipstick	Jauge à huile	Calibre de aceite
20	2314F002			Screw	Vis	Tornillo
21	3733A009			Bracket	Patte de fixation	Pata de fijación
22	2314F909			Screw	Vis	Tornillo
23	3575A061			Pipe Assy	Ensemble tuyauterie	Tubo, Conj.
24	36832137			Joint	Articulation	Articulación
25	2314H004	M8 x 25		Screw	Vis	Tornillo



820
TX760B

801 802 803 804 805 806 807 808 831 832 833 834

21010C15.1

6199042M3

1

Jan-06

Engine
Moteur
Motor

Oil Pan
Carter d'huile
Cárter de aceite

RG38043
RG38043
RG38043

C-21011-15.1-A

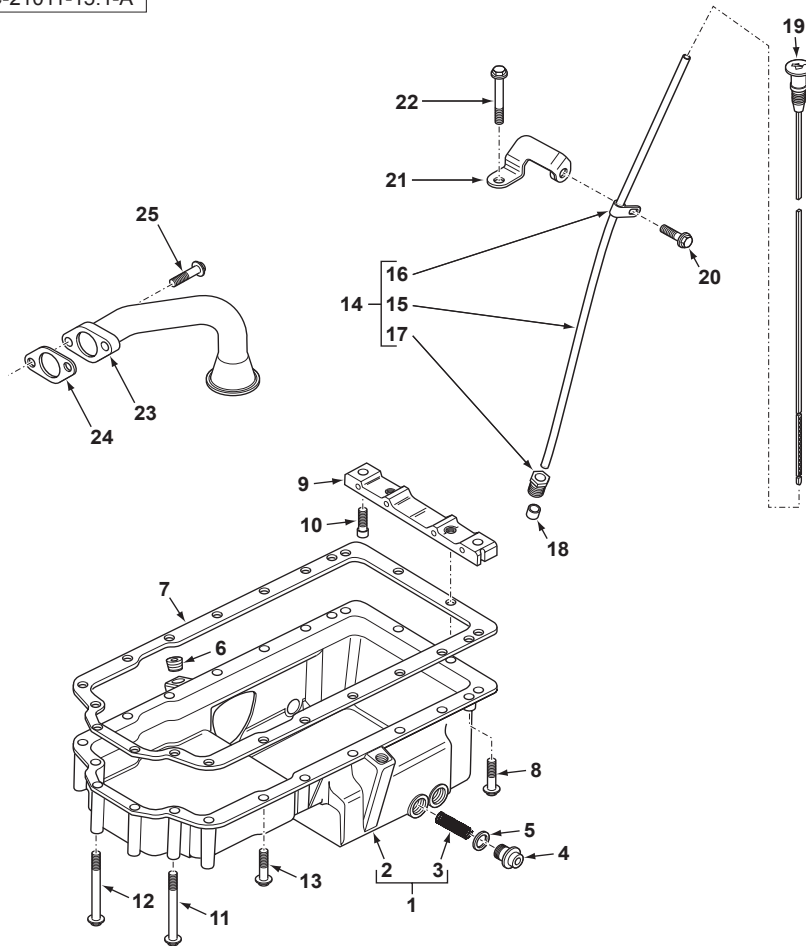

1	4145H091		1	Pan, Oil	Carter à huile	Cárter de aceite
2		1	▶ Ref. 1	Pan, Oil	Carter à huile	Cárter de aceite
3	2137435	1		Spring	Ressort	Muelle
4	32186405			Plug	Bouchon	Tapón
5	2415715			O-Ring	Joint torique	Junta de tipo O
6	2431A016			Plug	Bouchon	Tapón
7	3681K037			Joint	Articulation	Articulación
8	2314H033			Screw	Vis	Tornillo
9	3627P041			Plate	Plaque	Placa
10	2311D039			Screw	Vis	Tornillo
11	2314K166			Screw	Vis	Tornillo
12	2314K166			Screw	Vis	Tornillo
13	2314H003	M8 x 20		Screw	Vis	Tornillo
14	4126A081			Tube Assy	Tuyauterie	Conjunto de tubería
15		14	▶ Ref. 14	Tube	Tube	Tubo
16	0180170	14		Clip, Mounting	Collier de fixation	Argolla de fijación
17	3353D005	14		Nut	Écrou	Tuerca
18	33812116			Orifice	Orifice	Orificio
19	3178C169			Dipstick	Jauge à huile	Calibre de aceite
20	2314F002			Screw	Vis	Tornillo
21	3733A009			Bracket	Patte de fixation	Pata de fijación
22	2314F909			Screw	Vis	Tornillo
23	3575A061			Pipe Assy	Ensemble tuyauterie	Tubo, Conj.
24	36832137			Joint	Articulation	Articulación
25	2314H004	M8 x 25		Screw	Vis	Tornillo



820
TX760B

801 803 805 807 831 833

21011C15.1

6199042M3

1

Jan-06

Engine
Moteur
Motor

Oil Pan
Carter d'huile
Cárter de aceite

RG38099
RG38099
RG38099

C-21012-15.1-A

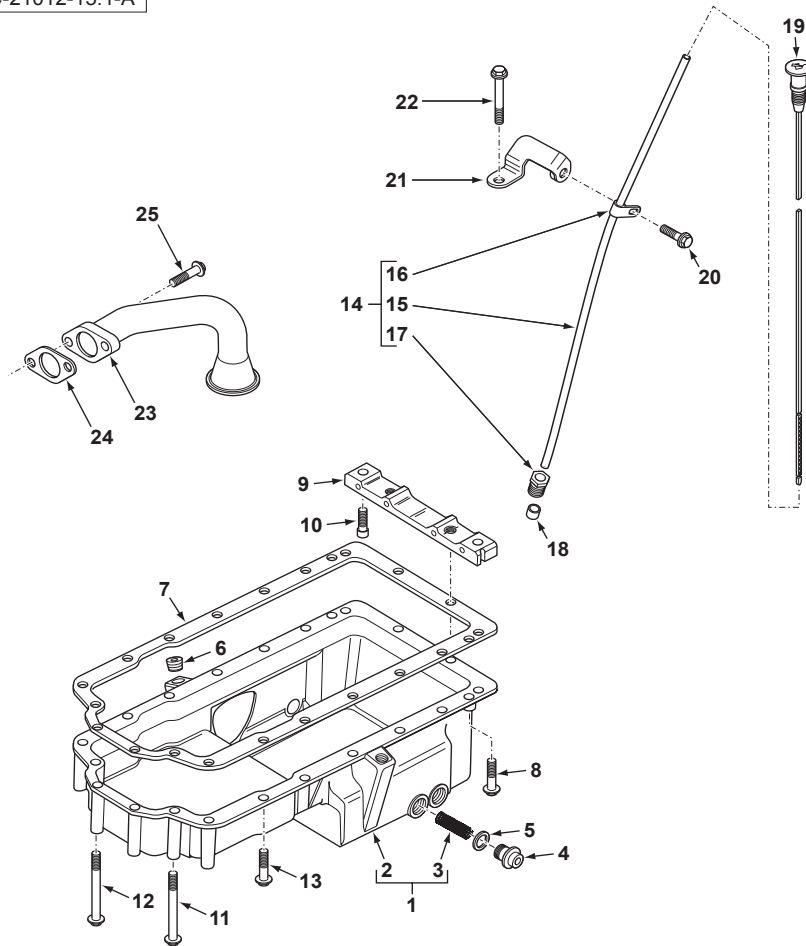

1	4145H091			1	Pan, Oil	Carter à huile	Cárter de aceite
2		1	➡ Ref. 1	1	Pan, Oil	Carter à huile	Cárter de aceite
3	2137435	1		2	Spring	Ressort	Muelle
4	32186405			2	Plug	Bouchon	Tapón
5	2415715			2	O-Ring	Joint torique	Junta de tipo O
6	2431A016			1	Plug	Bouchon	Tapón
7	3681K037			1	Joint	Articulation	Articulación
8	2314H033			2	Screw	Vis	Tornillo
9	3627P041			1	Plate	Plaque	Placa
10	2311D039			2	Screw	Vis	Tornillo
11	2314K166			2	Screw	Vis	Tornillo
12	2314K166			4	Screw	Vis	Tornillo
13	2314H003	M8 x 20		12	Screw	Vis	Tornillo
14	4126A081			1	Tube Assy	Tuyauterie	Conjunto de tubería
15		14	➡ Ref. 14	1	Tube	Tube	Tubo
16	0180170	14		1	Clip, Mounting	Collier de fixation	Argolla de fijación
17	3353D005	14		1	Nut	Écrou	Tuerca
18	33812116			1	Orifice	Orifice	Orificio
19	3178C169			1	Dipstick	Jauge à huile	Calibre de aceite
20	2314F002			1	Screw	Vis	Tornillo
21	3733A009			1	Bracket	Patte de fixation	Pata de fijación
22	2314F909			1	Screw	Vis	Tornillo
23	3575A061			1	Pipe Assy	Ensemble tuyauterie	Tubo, Conj.
24	36832137			1	Joint	Articulation	Articulación
25	2314H004	M8 x 25		2	Screw	Vis	Tornillo



860 880 970 980
TX860B TX870B
TX970B

809 810 811 812 813 814 815 816 817 821 822 823 824 825 841 842 843 844 845
851 852 853 854 855 921 922 923 931 932

21012C15.1

6199042M3

1

Jan-06

Engine
Moteur
Motor

Oil Pan
Carter d'huile
Cárter de aceite

RG38044
RG38044
RG38044

C-21013-15.1-A

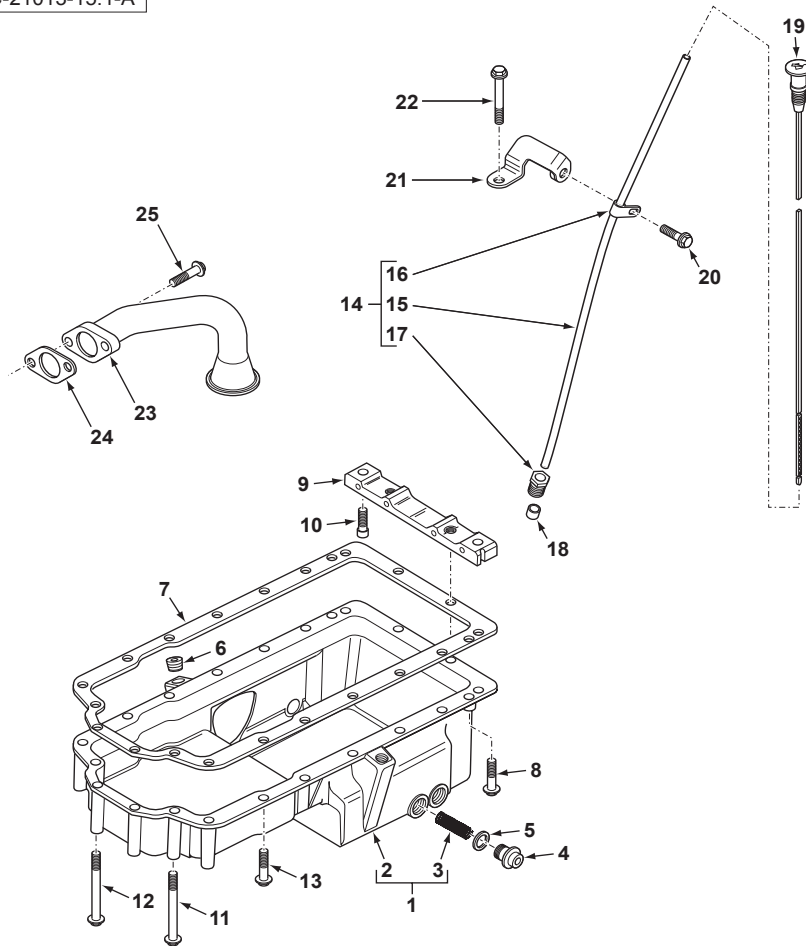

1	4145H091		1	Pan, Oil	Carter à huile	Cárter de aceite
2		1	▶ Ref. 1	Pan, Oil	Carter à huile	Cárter de aceite
3	2137435	1		Spring	Ressort	Muelle
4	32186405			Plug	Bouchon	Tapón
5	2415715			O-Ring	Joint torique	Junta de tipo O
6	2431A016			Plug	Bouchon	Tapón
7	3681K037			Joint	Articulation	Articulación
8	2314H033			Screw	Vis	Tornillo
9	3627P041			Plate	Plaque	Placa
10	2311D039			Screw	Vis	Tornillo
11	2314K166			Screw	Vis	Tornillo
12	2314K166			Screw	Vis	Tornillo
13	2314H003	M8 x 20		Screw	Vis	Tornillo
14	4126A081			Tube Assy	Tuyauterie	Conjunto de tubería
15		14	▶ Ref.14	Tube	Tube	Tubo
16	0180170	14		Clip, Mounting	Collier de fixation	Argolla de fijación
17	3353D005	14		Nut	Écrou	Tuerca
18	33812116			Orifice	Orifice	Orificio
19	3178C169			Dipstick	Jauge à huile	Calibre de aceite
20	2314F002			Screw	Vis	Tornillo
21	3733A009			Bracket	Patte de fixation	Pata de fijación
22	2314F909			Screw	Vis	Tornillo
23	3575A061			Pipe Assy	Ensemble tuyauterie	Tubo, Conj.
24	36832137			Joint	Articulation	Articulación
25	2314H004	M8 x 25		Screw	Vis	Tornillo



860 880 970 980
TX860B TX870B
TX970B

809 811 813 815 817 821 823 825 841 843 845 851 853 855 921 922 923 931 932

21013C15.1

6199042M3

1

Jan-06

Engine
Moteur
Motor

Oil Pump
Pompe à Huile
Bomba de aceite

RG38100
RG38100
RG38100

C-21010-17.1-A

1	4132F071	(A)	1	Pump, Engine Oil	Pompe à huile	Bomba de aceite
2	2314J008	M10 x 50	5	Screw	Vis	Tornillo

A Details to be advised
Détails à demander
Detalles que deben ser notificados

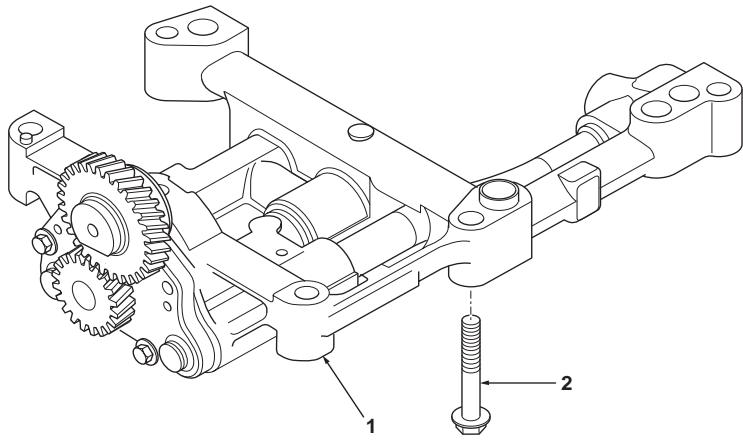

820
TX760B

801 802 803 804 805 806 807 808 831 832 833 834

Engine
Moteur
Motor

Oil Pump
Pompe à Huile
Bomba de aceite

RG38043
RG38043
RG38043

C-21011-17.1-A

1	4132F071	(A)	1	Pump, Engine Oil	Pompe à huile	Bomba de aceite
2	2314J008	M10 x 50	5	Screw	Vis	Tornillo

A Details to be advised
Détails à demander
Detalles que deben ser notificados

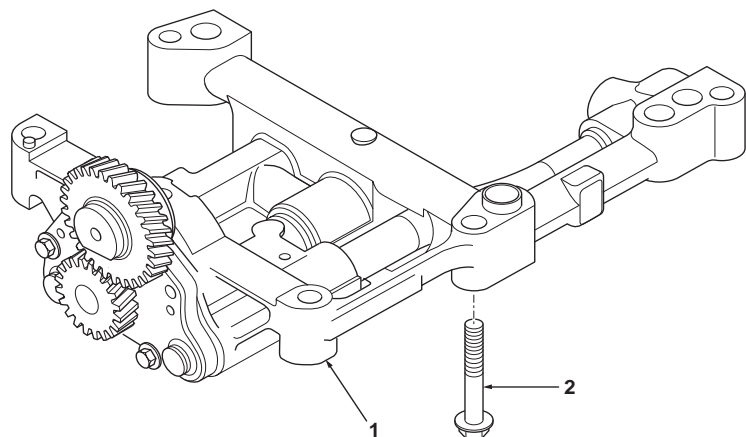

820
TX760B

801 803 805 807 831 833

Engine
Moteur
Motor

Oil Pump
Pompe à Huile
Bomba de aceite

RG38099
RG38099
RG38099

C-21012-17.1-A

1	4132F071	(A)	1	Pump, Engine Oil	Pompe à huile	Bomba de aceite
2	2314J008	M10 x 50	5	Screw	Vis	Tornillo

A Details to be advised
Détails à demander
Detalles que deben ser notificados

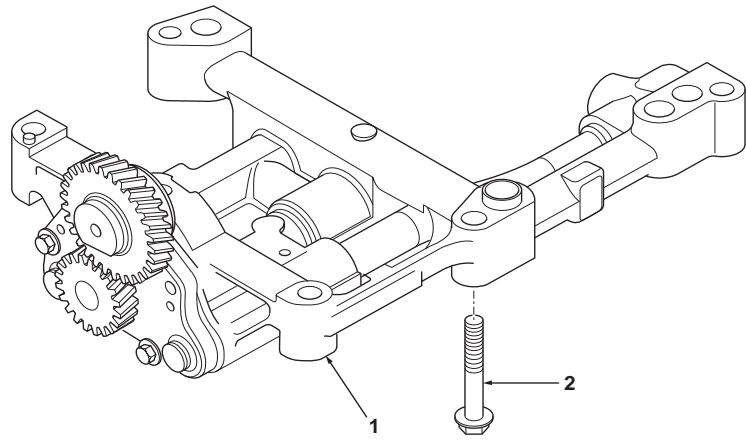

860 880 970 980
TX860B TX870B
TX970B

809 810 811 812 813 814 815 816 817 821 822 823 824 825 841 842 843 844 845
851 852 853 854 855 921 922 923 931 932

Engine
Moteur
Motor

Oil Pump
Pompe à Huile
Bomba de aceite

RG38044
RG38044
RG38044

C-21013-17.1-A

1	4132F071	(A)	1	Pump, Engine Oil	Pompe à huile	Bomba de aceite
2	2314J008	M10 x 50	5	Screw	Vis	Tornillo

A Details to be advised
Détails à demander
Detalles que deben ser notificados

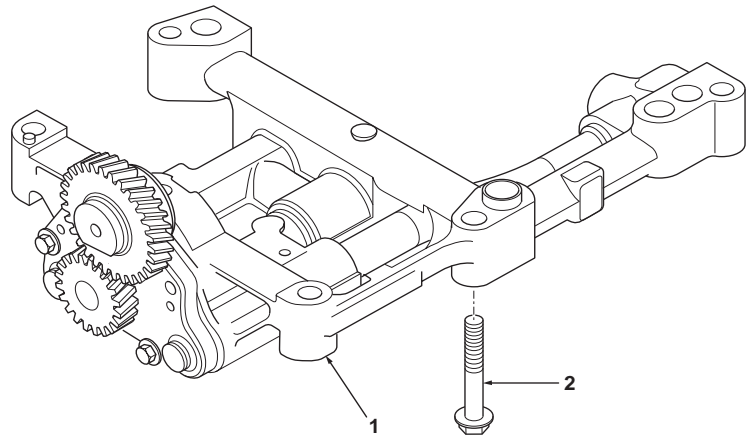

860 880 970 980
TX860B TX870B
TX970B

809 811 813 815 817 821 823 825 841 843 845 851 853 855 921 922 923 931 932

21013C17.1

6199042M3

1

Jan-06

Engine
Moteur
Motor

Pistons And Crankshaft
Pistons et Vilebrequin
Pistones y cigüeñal

RG38100
RG38100
RG38100

C-21010-03.1-A

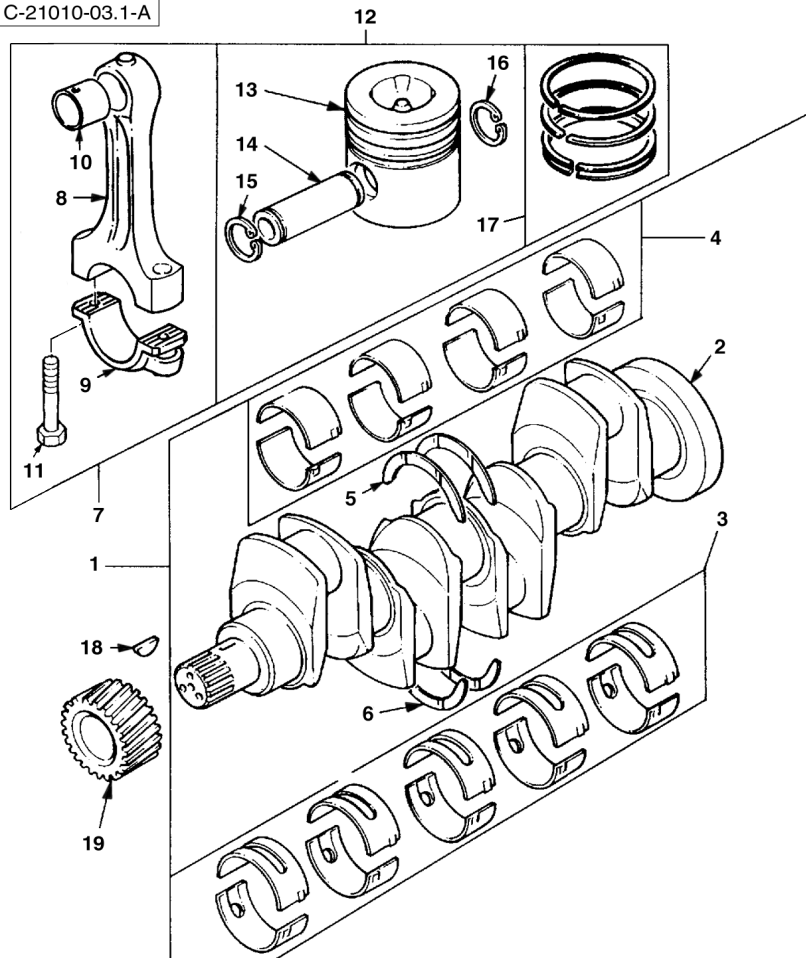

1			1	Crankshaft Assy	Ensemble vilebrequin	Cigüeñal, Conj.
2		1	➔ Ref. 1	Crankshaft	Vilebrequin	Cigüeñal
3	U5MB0018	1	Std.	Bearing, Gland	Coussinet de palier	Cojinete de palier
3	U5MB0018A	1	(+) 0.010"	X Bearing, Gland	Coussinet de palier	Cojinete de palier
3	U5MB0018B	1	(+) 0.020"	X Bearing, Gland	Coussinet de palier	Cojinete de palier
3	U5MB0018C	1	(+) 0.030"	X Bearing, Gland	Coussinet de palier	Cojinete de palier
4	U5ME0013	1	Std.	Bearing, Con. Rod	Coussinet de bielle	Cojinete de biela
4	U5ME0013A	1	(+) 0.010"	X Bearing, Con. Rod	Coussinet de bielle	Cojinete de biela
4	U5ME0013B	1	(+) 0.020"	X Bearing, Con. Rod	Coussinet de bielle	Cojinete de biela
4	U5ME0013C	1	(+) 0.030"	X Bearing, Con. Rod	Coussinet de bielle	Cojinete de biela
5	31137551	1		1 Shim	Cale	Calce
5	31137312	1		X Shim	Cale	Calce
6	31137561	1		1 Shim	Cale	Calce
6	31137322	1		X Shim	Cale	Calce
7	4115C311		Grade F	4 Rod Assy, Connecting	Ensemble de bielle	Biela, Conj.
7	4115C312		Grade G	4 Rod Assy, Connecting	Ensemble de bielle	Biela, Conj.
7	4115C313		Grade H	4 Rod Assy, Connecting	Ensemble de bielle	Biela, Conj.
7	4115C314		Grade J	4 Rod Assy, Connecting	Ensemble de bielle	Biela, Conj.
7	4115C315		Grade K	4 Rod Assy, Connecting	Ensemble de bielle	Biela, Conj.
7	4115C316		Grade L	4 Rod Assy, Connecting	Ensemble de bielle	Biela, Conj.
8		7	➔ Ref. 7	1 Rod, Connecting	Bielle	Biela
9		7	➔ Ref. 7	1 Cap	Chapeau	Sombbrero
10	3112A005	7		1 Bush	Bague	Casquillo
11	3212V003	7		2 Bolt	Boulon	Perno
12	4115P015			4 Piston Assy	Ensemble de piston	Pistón, Conj.
13		12	➔ Ref. 12	1 Piston	Piston	Pistón
14		12	➔ Ref. 12	1 Pin	Axe	Pasador
15	2721332	12		1 Circlip	Segment d'arrêt	Circlip
16	2721332	12		1 Circlip	Segment d'arrêt	Circlip
17	UPRK0002	12		1 Ring Set, Piston	Jeu de segments	Juego de segmentos
18	0500012			1 Key, Woodruff	Clavette demi-lune	Chaveta media-luna
19	3117C221			1 Gear	Pignon	Piñón



820
TX760B

801 802 803 804 805 806 807 808 831 832 833 834

21010C03.1

6199042M3

1

Jan-06

Engine
Moteur
Motor

Pistons And Crankshaft
Pistons et Vilebrequin
Pistones y cigüeñal

RG38043
RG38043
RG38043

C-21011-03.1-A

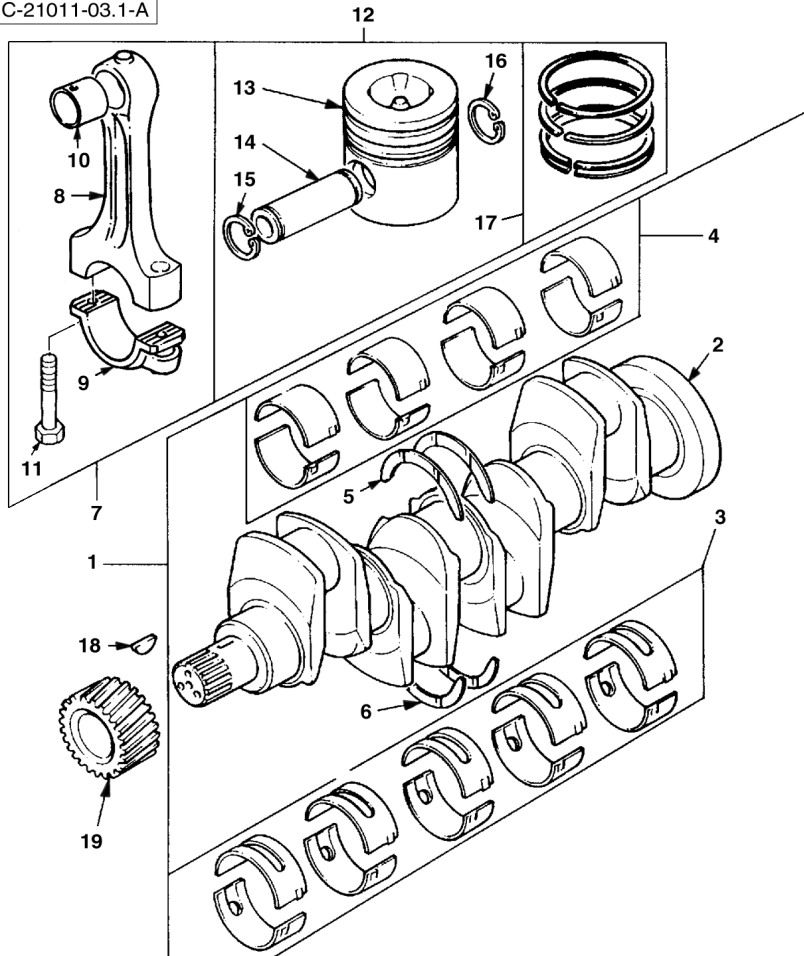

1	ZZ90222		1	Crankshaft Assy	Ensemble vilebrequin	Cigüeñal, Conj.
2		1	➡ Ref. 1	Crankshaft	Vilebrequin	Cigüeñal
3	U5MB0018	1	Std.	Bearing, Gland	Coussinet de palier	Cojinete de palier
3	U5MB0018A	1	(+) 0.010"	X Bearing, Gland	Coussinet de palier	Cojinete de palier
3	U5MB0018B	1	(+) 0.020"	X Bearing, Gland	Coussinet de palier	Cojinete de palier
3	U5MB0018C	1	(+) 0.030"	X Bearing, Gland	Coussinet de palier	Cojinete de palier
4	U5ME0013	1	Std.	Bearing, Con. Rod	Coussinet de bielle	Cojinete de biela
4	U5ME0013A	1	(+) 0.010"	X Bearing, Con. Rod	Coussinet de bielle	Cojinete de biela
4	U5ME0013B	1	(+) 0.020"	X Bearing, Con. Rod	Coussinet de bielle	Cojinete de biela
4	U5ME0013C	1	(+) 0.030"	X Bearing, Con. Rod	Coussinet de bielle	Cojinete de biela
5	31137551	1		1 Shim	Calce	Calce
5	31137312	1		X Shim	Calce	Calce
6	31137561	1		1 Shim	Calce	Calce
6	31137322	1		X Shim	Calce	Calce
7	4115C311		Grade F	4 Rod Assy, Connecting	Ensemble de bielle	Biela, Conj.
7	4115C312		Grade G	4 Rod Assy, Connecting	Ensemble de bielle	Biela, Conj.
7	4115C313		Grade H	4 Rod Assy, Connecting	Ensemble de bielle	Biela, Conj.
7	4115C314		Grade J	4 Rod Assy, Connecting	Ensemble de bielle	Biela, Conj.
7	4115C315		Grade K	4 Rod Assy, Connecting	Ensemble de bielle	Biela, Conj.
7	4115C316		Grade L	4 Rod Assy, Connecting	Ensemble de bielle	Biela, Conj.
8		7	➡ Ref. 7	1 Rod, Connecting	Bielle	Biela
9		7	➡ Ref. 7	1 Cap	Chapeau	Sombbrero
10	3112A005	7		1 Bush	Bague	Casquillo
11	3212V003	7		2 Bolt	Boulon	Perno
12	4115P015			4 Piston Assy	Ensemble de piston	Pistón, Conj.
13		12	➡ Ref. 12	1 Piston	Piston	Pistón
14		12	➡ Ref. 12	1 Pin	Axe	Pasador
15	2721332	12		1 Circlip	Segment d'arrêt	Circlip
16	2721332	12		1 Circlip	Segment d'arrêt	Circlip
17	UPRK0002	12		1 Ring Set, Piston	Jeu de segments	Juego de segmentos
18	0500012			1 Key, Woodruff	Clavette demi-lune	Chaveta media-luna
19	3117C221			1 Gear	Pignon	Piñón



820
TX760B

801 803 805 807 831 833

21011C03.1

6199042M3

1

Jan-06

Engine
Moteur
Motor

Pistons And Crankshaft
Pistons et Vilebrequin
Pistones y cigüeñal

RG38099
RG38099
RG38099

C-21012-03.1-A

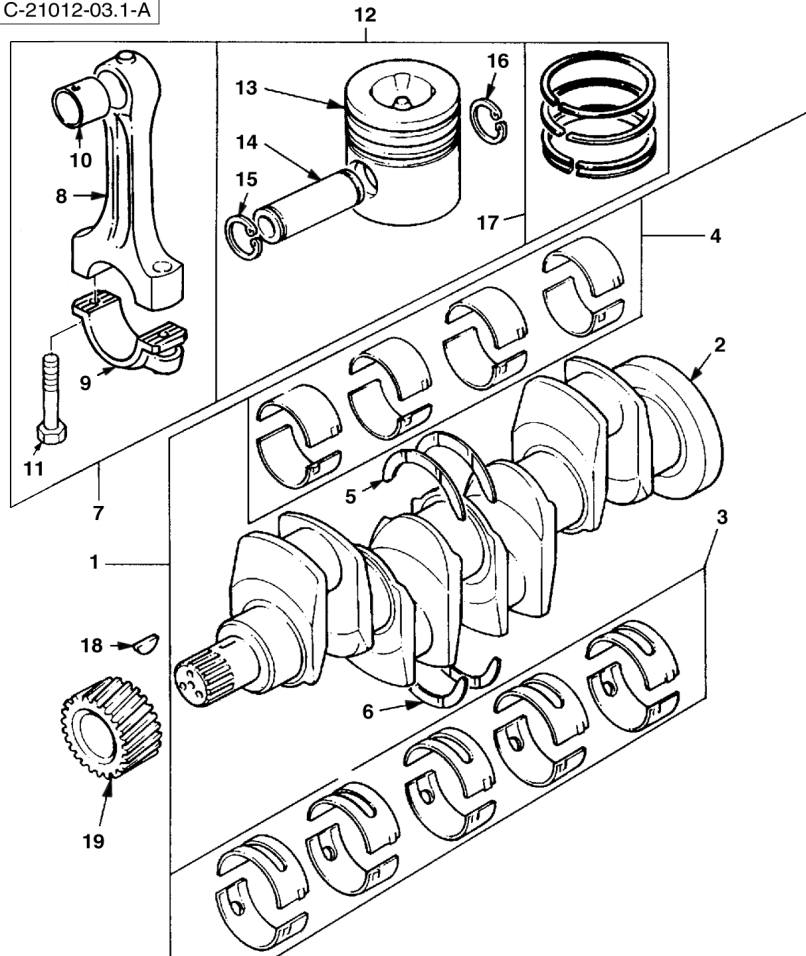

1	ZZ90222			1	Crankshaft Assy	Ensemble vilebrequin	Cigüeñal, Conj.
2		1	➡ Ref. 1	1	Crankshaft	Vilebrequin	Cigüeñal
3	U5MB0018	1	Std.	1	Bearing, Gland	Coussinet de palier	Cojinete de palier
3	U5MB0018A	1	(+) 0.010"	X	Bearing, Gland	Coussinet de palier	Cojinete de palier
3	U5MB0018B	1	(+) 0.020"	X	Bearing, Gland	Coussinet de palier	Cojinete de palier
3	U5MB0018C	1	(+) 0.030"	X	Bearing, Gland	Coussinet de palier	Cojinete de palier
4	U5ME0013	1	Std.	1	Bearing, Con. Rod	Coussinet de bielle	Cojinete de biela
4	U5ME0013A	1	(+) 0.010"	X	Bearing, Con. Rod	Coussinet de bielle	Cojinete de biela
4	U5ME0013B	1	(+) 0.020"	X	Bearing, Con. Rod	Coussinet de bielle	Cojinete de biela
4	U5ME0013C	1	(+) 0.030"	X	Bearing, Con. Rod	Coussinet de bielle	Cojinete de biela
5	31137551	1		1	Shim	Cale	Calce
5	31137312	1		X	Shim	Cale	Calce
6	31137561	1		1	Shim	Cale	Calce
6	31137322	1		X	Shim	Cale	Calce
7	4115C311		Grade F	4	Rod Assy, Connecting	Ensemble de bielle	Biela, Conj.
7	4115C312		Grade G	4	Rod Assy, Connecting	Ensemble de bielle	Biela, Conj.
7	4115C313		Grade H	4	Rod Assy, Connecting	Ensemble de bielle	Biela, Conj.
7	4115C314		Grade J	4	Rod Assy, Connecting	Ensemble de bielle	Biela, Conj.
7	4115C315		Grade K	4	Rod Assy, Connecting	Ensemble de bielle	Biela, Conj.
7	4115C316		Grade L	4	Rod Assy, Connecting	Ensemble de bielle	Biela, Conj.
8		7	➡ Ref. 7	1	Rod, Connecting	Bielle	Biela
9		7	➡ Ref. 7	1	Cap	Chapeau	Sombbrero
10	3112A005	7		1	Bush	Bague	Casquillo
11	3212V003	7		2	Bolt	Boulon	Perno
12	4115P015			4	Piston Assy	Ensemble de piston	Pistón, Conj.
13		12	➡ Ref. 12	1	Piston	Piston	Pistón
14		12	➡ Ref. 12	1	Pin	Axe	Pasador
15	2721332	12		1	Circlip	Segment d'arrêt	Circlip
16	2721332	12		1	Circlip	Segment d'arrêt	Circlip
17	UPRK0002	12		1	Ring Set, Piston	Jeu de segments	Juego de segmentos
18	0500012			1	Key, Woodruff	Clavette demi-lune	Chaveta media-luna
19	3117C221			1	Gear	Pignon	Piñón



860 880 970 980
TX860B TX870B
TX970B

809 810 811 812 813 814 815 816 817 821 822 823 824 825 841 842 843 844 845
851 852 853 854 855 921 922 923 931 932

21012C03.1

6199042M3

1

Jan-06

Engine
Moteur
Motor

Pistons And Crankshaft
Pistons et Vilebrequin
Pistones y cigüeñal

RG38044
RG38044
RG38044

C-21013-03.1-A

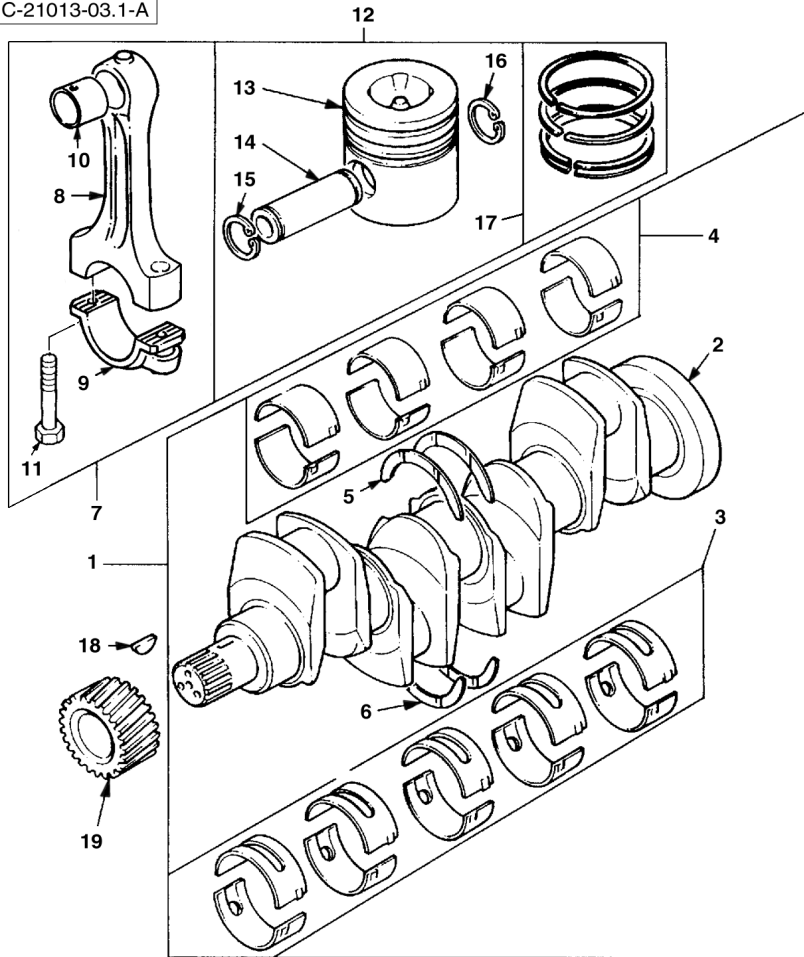

1	ZZ90222			1	Crankshaft Assy	Ensemble vilebrequin	Cigüeñal, Conj.
2		1	➡ Ref. 1	1	Crankshaft	Vilebrequin	Cigüeñal
3	U5MB0018	1	Std.	1	Bearing, Gland	Coussinet de palier	Cojinete de palier
3	U5MB0018A	1	(+) 0.010"	X	Bearing, Gland	Coussinet de palier	Cojinete de palier
3	U5MB0018B	1	(+) 0.020"	X	Bearing, Gland	Coussinet de palier	Cojinete de palier
3	U5MB0018C	1	(+) 0.030"	X	Bearing, Gland	Coussinet de palier	Cojinete de palier
4	U5ME0013	1	Std.	1	Bearing, Con. Rod	Coussinet de bielle	Cojinete de biela
4	U5ME0013A	1	(+) 0.010"	X	Bearing, Con. Rod	Coussinet de bielle	Cojinete de biela
4	U5ME0013B	1	(+) 0.020"	X	Bearing, Con. Rod	Coussinet de bielle	Cojinete de biela
4	U5ME0013C	1	(+) 0.030"	X	Bearing, Con. Rod	Coussinet de bielle	Cojinete de biela
5	31137551	1		1	Shim	Calce	Calce
5	31137312	1		X	Shim	Calce	Calce
6	31137561	1		1	Shim	Calce	Calce
6	31137322	1		X	Shim	Calce	Calce
7	4115C311		Grade F	4	Rod Assy, Connecting	Ensemble de bielle	Biela, Conj.
7	4115C312		Grade G	4	Rod Assy, Connecting	Ensemble de bielle	Biela, Conj.
7	4115C313		Grade H	4	Rod Assy, Connecting	Ensemble de bielle	Biela, Conj.
7	4115C314		Grade J	4	Rod Assy, Connecting	Ensemble de bielle	Biela, Conj.
7	4115C315		Grade K	4	Rod Assy, Connecting	Ensemble de bielle	Biela, Conj.
7	4115C316		Grade L	4	Rod Assy, Connecting	Ensemble de bielle	Biela, Conj.
8		7	➡ Ref. 7	1	Rod, Connecting	Bielle	Biela
9		7	➡ Ref. 7	1	Cap	Chapeau	Sombbrero
10	3112A005	7		1	Bush	Bague	Casquillo
11	3212V003	7		2	Bolt	Boulon	Perno
12	4115P015			4	Piston Assy	Ensemble de piston	Pistón, Conj.
13		12	➡ Ref. 12	1	Piston	Piston	Pistón
14		12	➡ Ref. 12	1	Pin	Axe	Pasador
15	2721332	12		1	Circlip	Segment d'arrêt	Circlip
16	2721332	12		1	Circlip	Segment d'arrêt	Circlip
17	UPRK0002	12		1	Ring Set, Piston	Jeu de segments	Juego de segmentos
18	0500012			1	Key, Woodruff	Clavette demi-lune	Chaveta media-luna
19	3117C221			1	Gear	Pignon	Piñón



860 880 970 980
TX860B TX870B
TX970B

809 811 813 815 817 821 823 825 841 843 845 851 853 855 921 922 923 931 932

21013C03.1

6199042M3

1

Jan-06

Engine
Moteur
Motor

Plug And Blank-Off Plug
Bouchon et Obturateur
Tapón y obturador

RG38100
RG38100
RG38100

C-21010-24.1-A

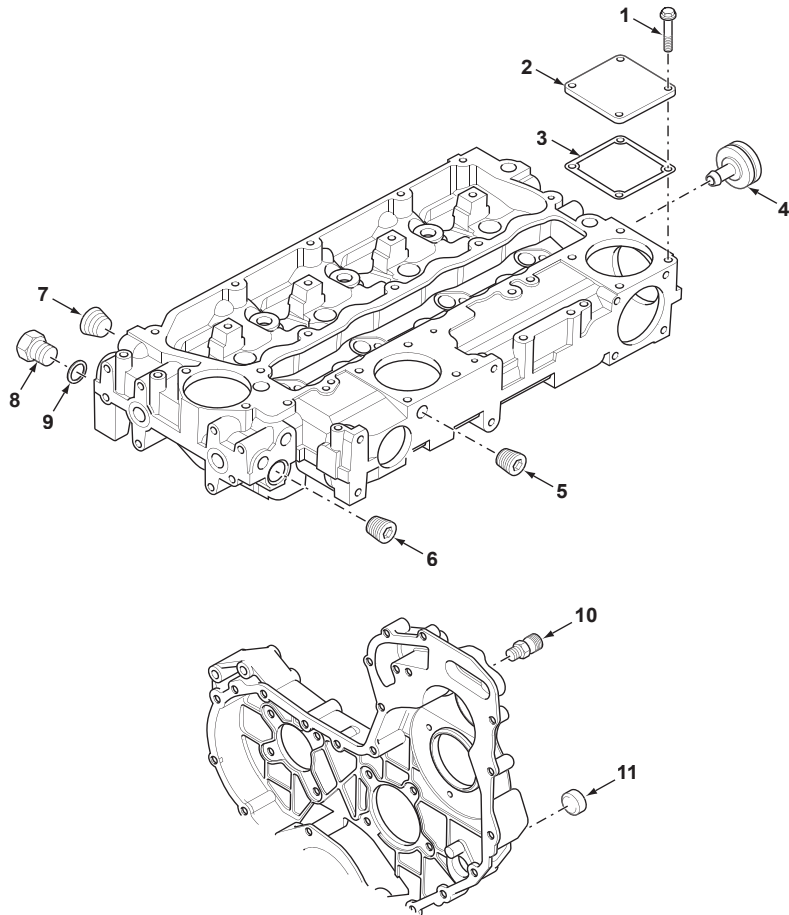

1	2314H003	M8 x 20	12	Screw	Vis	Tornillo
2	3611M006		3	Plate	Plaque	Placa
3	3684N503		3	Seal	Joint	Junta
4	3347A023		1	Adaptor	Adaptateur	Adaptador
5	2431131		1	Plug	Bouchon	Tapón
6	2431154		1	Plug	Bouchon	Tapón
7	2431154		1	Plug	Bouchon	Tapón
8	3278A006		1	Plug	Bouchon	Tapón
9	2415H003		1	O-Ring	Joint torique	Junta de tipo O
10	33552414		1	Adaptor	Adaptateur	Adaptador
11	2485A118		1	Plug, Blanking	Bouchon mâle, obturation	Tapón de bloqueo



820
TX760B

801 802 803 804 805 806 807 808 831 832 833 834

21010C24.1

6199042M3

1

Jan-06

Engine
Moteur
Motor

Plug And Blank-Off Plug
Bouchon et Obturateur
Tapón y obturador

RG38043
RG38043
RG38043

C-21011-24.1-A

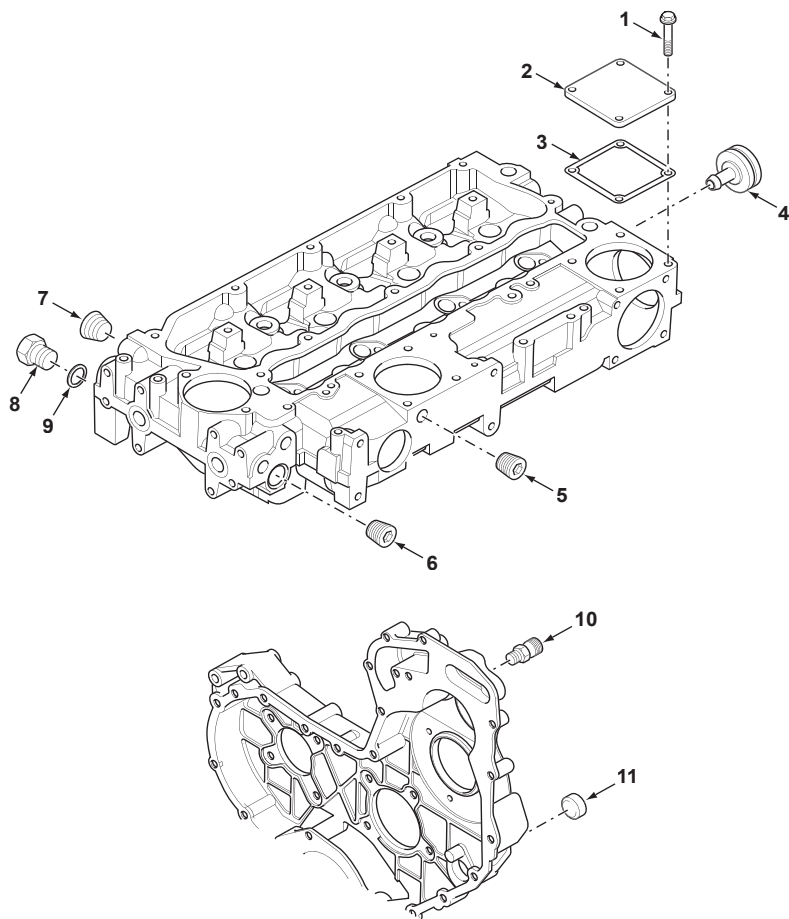

1	2314H003	M8 x 20	12	Screw	Vis	Tornillo
2	3611M006		3	Plate	Plaque	Placa
3	3684N503		3	Seal	Joint	Junta
4	3347A023		1	Adaptor	Adaptateur	Adaptador
5	2431131		1	Plug	Bouchon	Tapón
6	2431154		1	Plug	Bouchon	Tapón
7	2431154		1	Plug	Bouchon	Tapón
8	3278A006		1	Plug	Bouchon	Tapón
9	2415H003		1	O-Ring	Joint torique	Junta de tipo O
10	33552414		1	Adaptor	Adaptateur	Adaptador
11	2485A118		1	Plug, Blanking	Bouchon mâle, obturation	Tapón de bloqueo



820
TX760B

801 803 805 807 831 833

21011C24.1

6199042M3

1

Jan-06

Engine
Moteur
Motor

Plug And Blank-Off Plug
Bouchon et Obturateur
Tapón y obturador

RG38099
RG38099
RG38099

C-21012-24.1-A

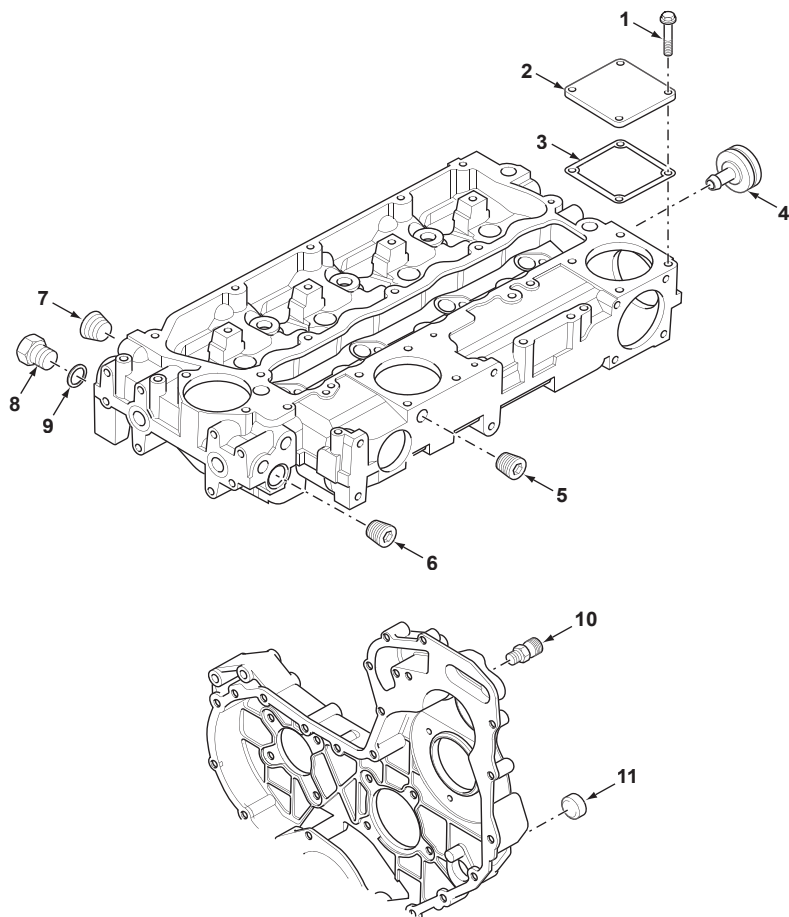

1	2314H003	M8 x 20	12	Screw	Vis	Tornillo
2	3611M006		3	Plate	Plaque	Placa
3	3684N503		3	Seal	Joint	Junta
4	3347A023		1	Adaptor	Adaptateur	Adaptador
5	2431131		1	Plug	Bouchon	Tapón
6	2431154		1	Plug	Bouchon	Tapón
7	2431154		1	Plug	Bouchon	Tapón
8	3278A006		1	Plug	Bouchon	Tapón
9	2415H003		1	O-Ring	Joint torique	Junta de tipo O
10	33552414		1	Adaptor	Adaptateur	Adaptador
11	2485A118		1	Plug, Blanking	Bouchon mâle, obturation	Tapón de bloqueo



860 880 970 980
TX860B TX870B
TX970B

809 810 811 812 813 814 815 816 817 821 822 823 824 825 841 842 843 844 845
851 852 853 854 855 921 922 923 931 932

21012C24.1

6199042M3

1

Jan-06

Engine
Moteur
Motor

Plug And Blank-Off Plug
Bouchon et Obturateur
Tapón y obturador

RG38044
RG38044
RG38044

C-21013-24.1-A

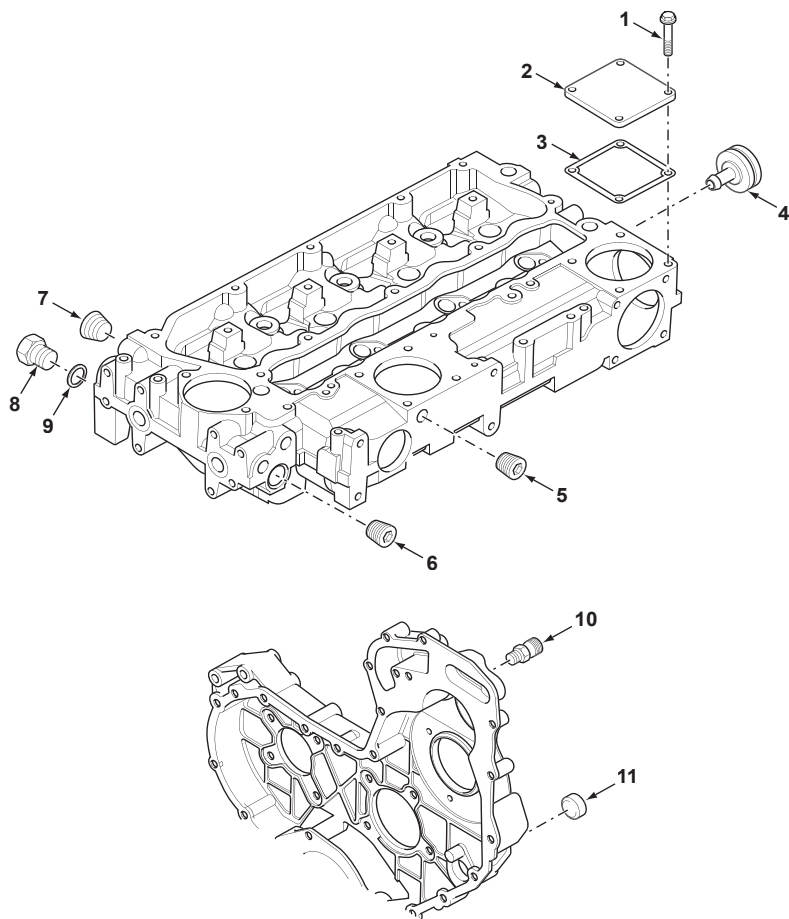

1	2314H003	M8 x 20	12	Screw	Vis	Tornillo
2	3611M006		3	Plate	Plaque	Placa
3	3684N503		3	Seal	Joint	Junta
4	3347A023		1	Adaptor	Adaptateur	Adaptador
5	2431131		1	Plug	Bouchon	Tapón
6	2431154		1	Plug	Bouchon	Tapón
7	2431154		1	Plug	Bouchon	Tapón
8	3278A006		1	Plug	Bouchon	Tapón
9	2415H003		1	O-Ring	Joint torique	Junta de tipo O
10	33552414		1	Adaptor	Adaptateur	Adaptador
11	2485A118		1	Plug, Blanking	Bouchon mâle, obturation	Tapón de bloqueo



860 880 970 980
TX860B TX870B
TX970B

809 811 813 815 817 821 823 825 841 843 845 851 853 855 921 922 923 931 932

21013C24.1

6199042M3

1

Jan-06

Engine
Moteur
Motor

Rockers
Culbuteurs
Balancines de válvula

RG38100
RG38100
RG38100

C-21010-05.1-A

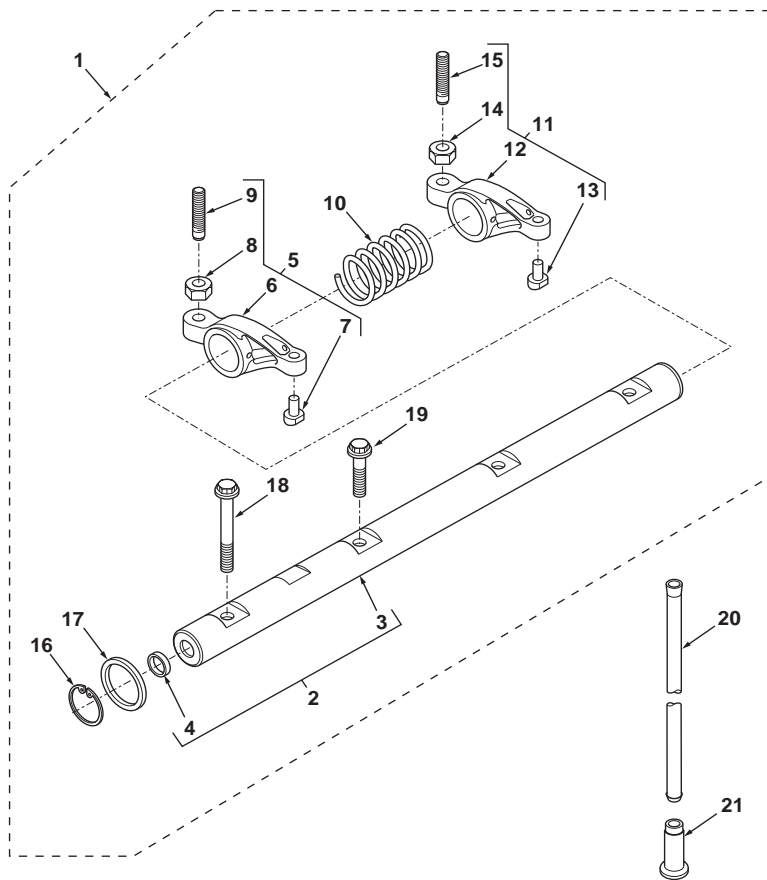

1	4115R612			1	Shaft Assy	Ensemble de l'arbre	Árbol, Conj.
2	4115R703	1		1	Shaft Assy	Ensemble de l'arbre	Árbol, Conj.
3		1	➤ Ref. 2	1	Shaft	Arbre	Árbol
4	2485A104	1		2	Plug	Bouchon	Tapón
5	4115R314	1		4	Arm, Rocker	Culbuteur	Balancín de válvula
6		5	➤ Ref. 5	1	Arm	Bras	Brazo
7		5	➤ Ref. 5	1	Pad	Plaque antidérapante	Cinta antideslizante
8	0576052	5		1	Nut	Écrou	Tuerca
9	32114145	5		1	Screw	Vis	Tornillo
10	3174A015	1		3	Spring	Ressort	Muelle
11	4115R315	1		4	Arm, Rocker	Culbuteur	Balancín de válvula
12		11	➤ Ref. 11	1	Arm	Bras	Brazo
13		11	➤ Ref. 11	1	Pad	Plaque antidérapante	Cinta antideslizante
14	0576052	11		1	Nut	Écrou	Tuerca
15	32114145	11		1	Screw	Vis	Tornillo
16	2722A022	1		2	Circlip	Segment d'arrêt	Circlip
17	2134A502	1		2	Washer	Rondelle	Arandela
18	2316A901	1		1	Screw	Vis	Tornillo
19	2316A902	1		3	Screw	Vis	Tornillo
20	31434307			8	Stem	Tige	Varilla
21	3142U031			8	Tappet	Poussoir	Pulsador



820
TX760B

801 802 803 804 805 806 807 808 831 832 833 834

21010C05.1

6199042M3

1

Jan-06

Engine
Moteur
Motor

Rockers
Culbuteurs
Balancines de válvula

RG38043
RG38043
RG38043

C-21011-05.1-A

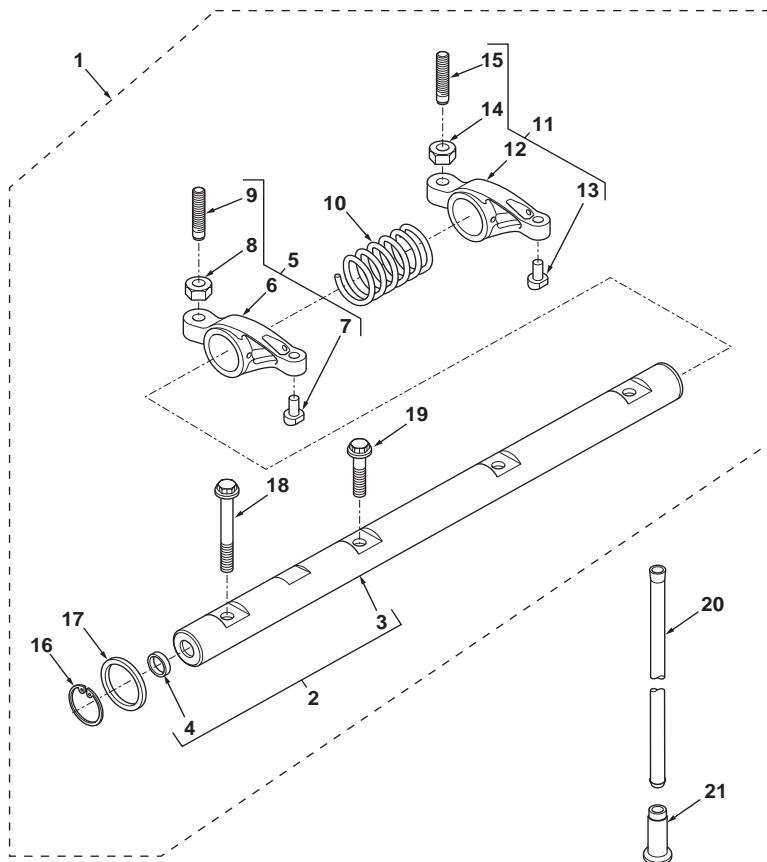

1	4115R612			1	Shaft Assy	Ensemble de l'arbre	Árbol, Conj.
2	4115R703	1		1	Shaft Assy	Ensemble de l'arbre	Árbol, Conj.
3		1	➤ Ref. 2	1	Shaft	Arbre	Árbol
4	2485A104	1		2	Plug	Bouchon	Tapón
5	4115R314	1		4	Arm, Rocker	Culbuteur	Balancín de válvula
6		5	➤ Ref. 5	1	Arm	Bras	Brazo
7		5	➤ Ref. 5	1	Pad	Plaque antidérapante	Cinta antideslizante
8	0576052	5		1	Nut	Écrou	Tuerca
9	32114145	5		1	Screw	Vis	Tornillo
10	3174A015	1		3	Spring	Ressort	Muelle
11	4115R315	1		4	Arm, Rocker	Culbuteur	Balancín de válvula
12		11	➤ Ref. 11	1	Arm	Bras	Brazo
13		11	➤ Ref. 11	1	Pad	Plaque antidérapante	Cinta antideslizante
14	0576052	11		1	Nut	Écrou	Tuerca
15	32114145	11		1	Screw	Vis	Tornillo
16	2722A022	1		2	Circlip	Segment d'arrêt	Circlip
17	2134A502	1		2	Washer	Rondelle	Arandela
18	2316A901	1		1	Screw	Vis	Tornillo
19	2316A902	1		3	Screw	Vis	Tornillo
20	31434307			8	Stem	Tige	Varilla
21	3142U031			8	Tappet	Poussoir	Pulsador



820
TX760B

801 803 805 807 831 833

21011C05.1

6199042M3

1

Jan-06

Engine
Moteur
Motor

Rockers
Culbuteurs
Balancines de válvula

RG38099
RG38099
RG38099

C-21012-05.1-A

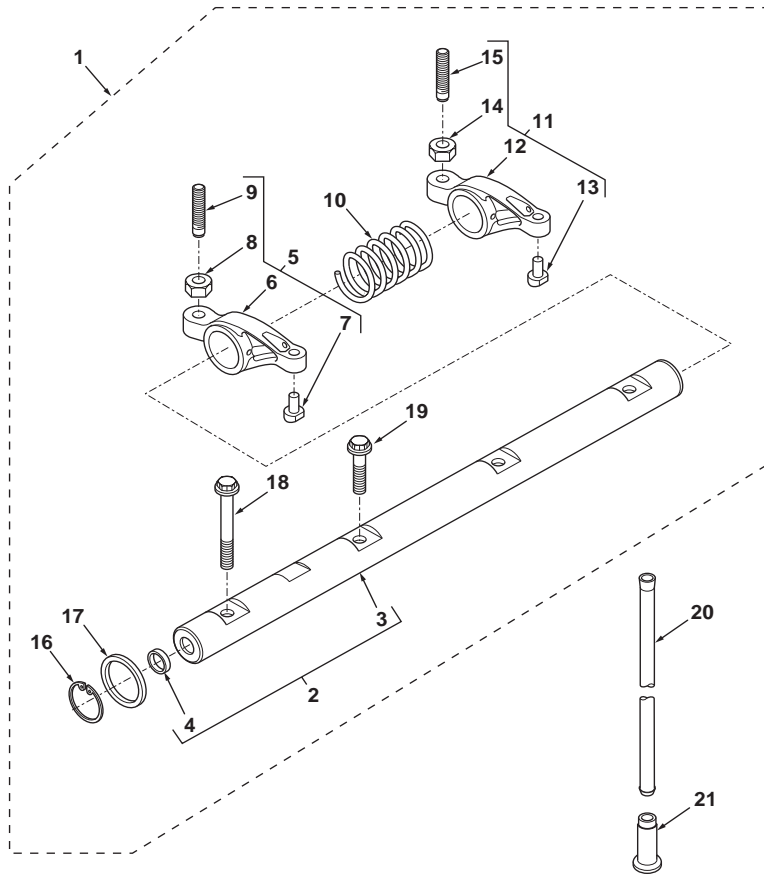

1	4115R612			1	Shaft Assy	Ensemble de l'arbre	Árbol, Conj.
2	4115R703	1		1	Shaft Assy	Ensemble de l'arbre	Árbol, Conj.
3		1	➤ Ref. 2	1	Shaft	Arbre	Árbol
4	2485A104	1		2	Plug	Bouchon	Tapón
5	4115R314	1		4	Arm, Rocker	Culbuteur	Balancín de válvula
6		5	➤ Ref. 5	1	Arm	Bras	Brazo
7		5	➤ Ref. 5	1	Pad	Plaque antidérapante	Cinta antideslizante
8	0576052	5		1	Nut	Écrou	Tuerca
9	32114145	5		1	Screw	Vis	Tornillo
10	3174A015	1		3	Spring	Ressort	Muelle
11	4115R315	1		4	Arm, Rocker	Culbuteur	Balancín de válvula
12		11	➤ Ref. 11	1	Arm	Bras	Brazo
13		11	➤ Ref. 11	1	Pad	Plaque antidérapante	Cinta antideslizante
14	0576052	11		1	Nut	Écrou	Tuerca
15	32114145	11		1	Screw	Vis	Tornillo
16	2722A022	1		2	Circlip	Segment d'arrêt	Circlip
17	2134A502	1		2	Washer	Rondelle	Arandela
18	2316A901	1		1	Screw	Vis	Tornillo
19	2316A902	1		3	Screw	Vis	Tornillo
20	31434307			8	Stem	Tige	Varilla
21	3142U031			8	Tappet	Poussoir	Pulsador



860 880 970 980
TX860B TX870B
TX970B

809 810 811 812 813 814 815 816 817 821 822 823 824 825 841 842 843 844 845
851 852 853 854 855 921 922 923 931 932

21012C05.1

6199042M3

1

Jan-06

Engine
Moteur
Motor

Rockers
Culbuteurs
Balancines de válvula

RG38044
RG38044
RG38044

C-21013-05.1-A

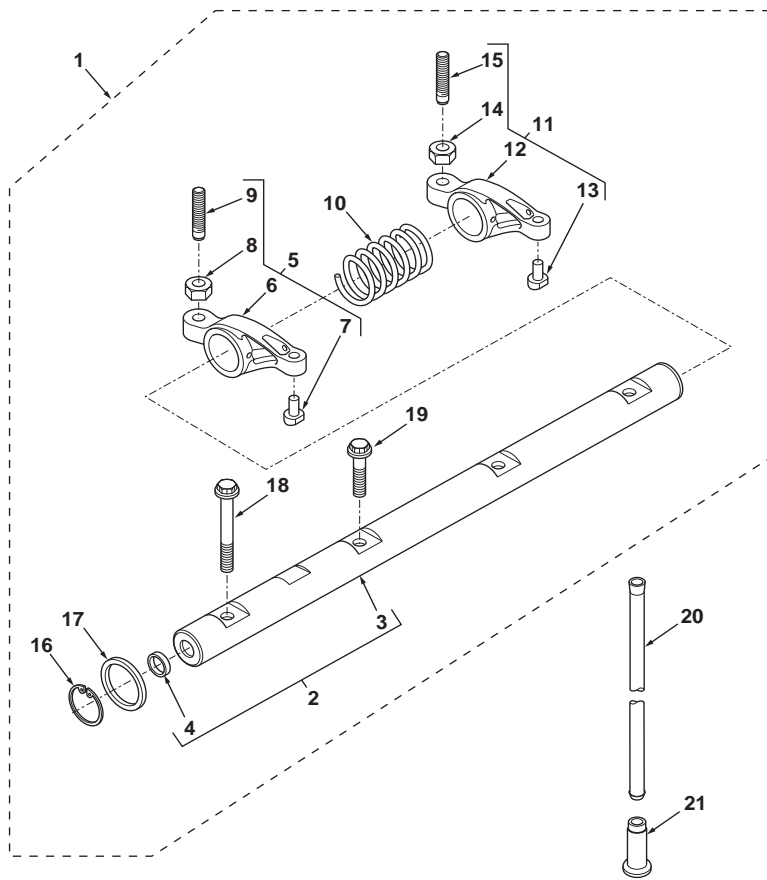

1	4115R612			1	Shaft Assy	Ensemble de l'arbre	Árbol, Conj.
2	4115R703	1		1	Shaft Assy	Ensemble de l'arbre	Árbol, Conj.
3		1	➤ Ref. 2	1	Shaft	Arbre	Árbol
4	2485A104	1		2	Plug	Bouchon	Tapón
5	4115R314	1		4	Arm, Rocker	Culbuteur	Balancín de válvula
6		5	➤ Ref. 5	1	Arm	Bras	Brazo
7		5	➤ Ref. 5	1	Pad	Plaque antidérapante	Cinta antideslizante
8	0576052	5		1	Nut	Écrou	Tuerca
9	32114145	5		1	Screw	Vis	Tornillo
10	3174A015	1		3	Spring	Ressort	Muelle
11	4115R315	1		4	Arm, Rocker	Culbuteur	Balancín de válvula
12		11	➤ Ref. 11	1	Arm	Bras	Brazo
13		11	➤ Ref. 11	1	Pad	Plaque antidérapante	Cinta antideslizante
14	0576052	11		1	Nut	Écrou	Tuerca
15	32114145	11		1	Screw	Vis	Tornillo
16	2722A022	1		2	Circlip	Segment d'arrêt	Circlip
17	2134A502	1		2	Washer	Rondelle	Arandela
18	2316A901	1		1	Screw	Vis	Tornillo
19	2316A902	1		3	Screw	Vis	Tornillo
20	31434307			8	Stem	Tige	Varilla
21	3142U031			8	Tappet	Poussoir	Pulsador



860 880 970 980
TX860B TX870B
TX970B

809 811 813 815 817 821 823 825 841 843 845 851 853 855 921 922 923 931 932

21013C05.1

6199042M3

1

Jan-06

Engine
Moteur
Motor

Thermostat And Water Filter
Thermostat et Filtre à Eau
Termostato y filtro de agua

RG38100
RG38100
RG38100

C-21010-10.1-A

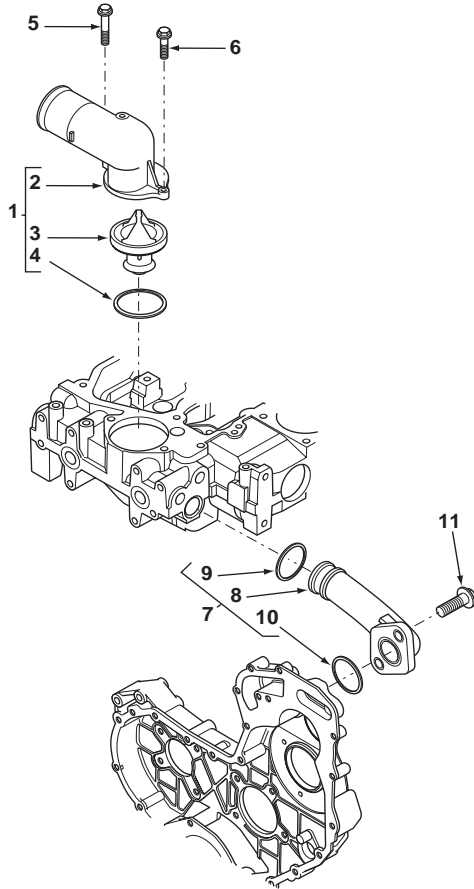

1	4133L503			1	Manifold Assy	Ensemble du collecteur	Colector, Conj.
2		1	➡ Ref. 1	1	Pipe	Tuyau	Tubo
3	2485C041P	1		1	Thermostat	Thermostat	Termostato
4	2415H008	1		1	O-Ring	Joint torique	Junta de tipo O
5	2314H012			1	Screw	Vis	Tornillo
6	2314H004		M8 x 25	1	Screw	Vis	Tornillo
7	4133L048			1	Connector Assy	Ensemble connexion	Conexión, Conj.
8		7	➡ Ref. 7	1	Pipe	Tuyau	Tubo
9	2418F002	7		1	O-Ring	Joint torique	Junta de tipo O
10	2418F001	7		1	O-Ring	Joint torique	Junta de tipo O
11	2314H003		M8 x 20	2	Screw	Vis	Tornillo



820
TX760B

801 802 803 804 805 806 807 808 831 832 833 834

21010C10.1

6199042M3

1

Jan-06

Engine
Moteur
Motor

Thermostat And Water Filter
Thermostat et Filtre à Eau
Termostato y filtro de agua

RG38043
RG38043
RG38043

C-21011-10.1-A

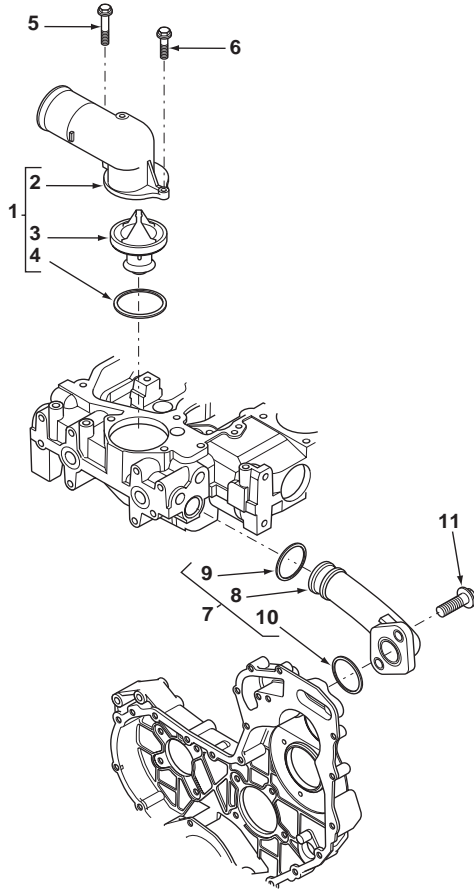

1	4133L503			1	Manifold Assy	Ensemble du collecteur	Colector, Conj.
2		1	➡ Ref. 1	1	Pipe	Tuyau	Tubo
3	2485C041P	1		1	Thermostat	Thermostat	Termostato
4	2415H008	1		1	O-Ring	Joint torique	Junta de tipo O
5	2314H012			1	Screw	Vis	Tornillo
6	2314H004		M8 x 25	1	Screw	Vis	Tornillo
7	4133L048			1	Connector Assy	Ensemble connexion	Conexión, Conj.
8		7	➡ Ref. 7	1	Pipe	Tuyau	Tubo
9	2418F002	7		1	O-Ring	Joint torique	Junta de tipo O
10	2418F001	7		1	O-Ring	Joint torique	Junta de tipo O
11	2314H003		M8 x 20	2	Screw	Vis	Tornillo



820
TX760B

801 803 805 807 831 833

21011C10.1

6199042M3

1

Jan-06

Engine
Moteur
Motor

Thermostat And Water Filter
Thermostat et Filtre à Eau
Termostato y filtro de agua

RG38099
RG38099
RG38099

C-21012-10.1-A

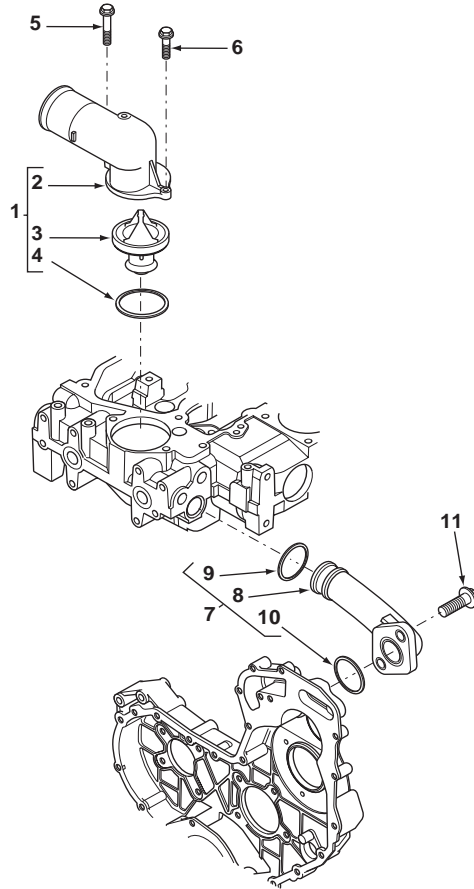

1	4133L503			1	Manifold Assy	Ensemble du collecteur	Colector, Conj.
2		1	➡ Ref. 1	1	Pipe	Tuyau	Tubo
3	2485C041P	1		1	Thermostat	Thermostat	Termostato
4	2415H008	1		1	O-Ring	Joint torique	Junta de tipo O
5	2314H012			1	Screw	Vis	Tornillo
6	2314H004		M8 x 25	1	Screw	Vis	Tornillo
7	4133L048			1	Connector Assy	Ensemble connexion	Conexión, Conj.
8		7	➡ Ref. 7	1	Pipe	Tuyau	Tubo
9	2418F002	7		1	O-Ring	Joint torique	Junta de tipo O
10	2418F001	7		1	O-Ring	Joint torique	Junta de tipo O
11	2314H003		M8 x 20	2	Screw	Vis	Tornillo



860 880 970 980
TX860B TX870B
TX970B

809 810 811 812 813 814 815 816 817 821 822 823 824 825 841 842 843 844 845
851 852 853 854 855 921 922 923 931 932

21012C10.1

6199042M3

1

Jan-06

Engine
Moteur
Motor

Thermostat And Water Filter
Thermostat et Filtre à Eau
Termostato y filtro de agua

RG38044
RG38044
RG38044

C-21013-10.1-A

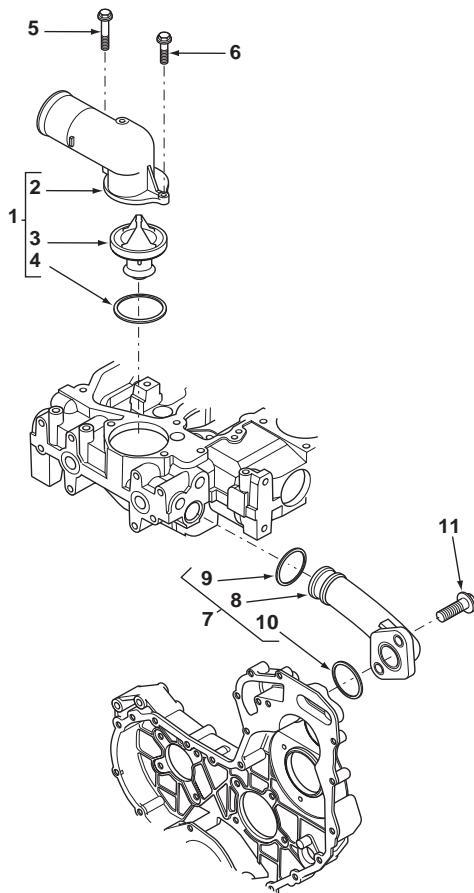

1	4133L503			1	Manifold Assy	Ensemble du collecteur	Colector, Conj.
2		1	➡ Ref. 1	1	Pipe	Tuyau	Tubo
3	2485C041P	1		1	Thermostat	Thermostat	Termostato
4	2415H008	1		1	O-Ring	Joint torique	Junta de tipo O
5	2314H012			1	Screw	Vis	Tornillo
6	2314H004		M8 x 25	1	Screw	Vis	Tornillo
7	4133L048			1	Connector Assy	Ensemble connexion	Conexión, Conj.
8		7	➡ Ref. 7	1	Pipe	Tuyau	Tubo
9	2418F002	7		1	O-Ring	Joint torique	Junta de tipo O
10	2418F001	7		1	O-Ring	Joint torique	Junta de tipo O
11	2314H003		M8 x 20	2	Screw	Vis	Tornillo



860 880 970 980
TX860B TX870B
TX970B

809 811 813 815 817 821 823 825 841 843 845 851 853 855 921 922 923 931 932

21013C10.1

6199042M3

1

Jan-06

Engine
Moteur
Motor

Turbocharger Connections
Raccords de Turbocompresseur
Racores de turbocompresor

RG38100
RG38100
RG38100

C-21010-08.1-A

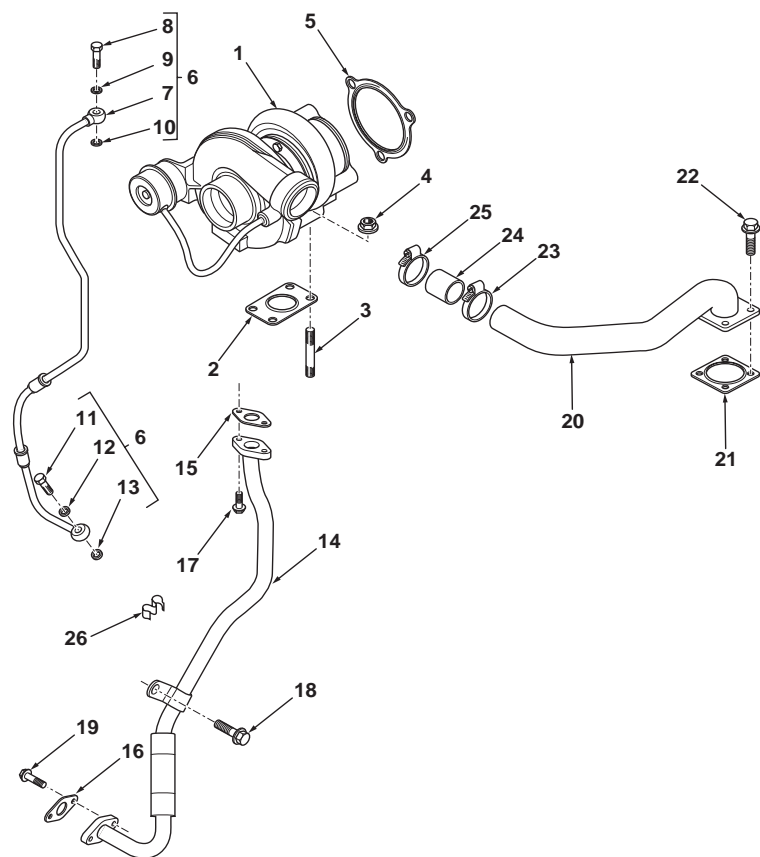

1	2674A226			1	Turbocharger Assy	Ensemble turbocompr.	Turbocompresor, Conj.
2	3688A029			1	Joint	Articulation	Articulación
3	3254K013			4	Stud	Goujon	Espárrago
4	2318A634			4	Nut	Écrou	Tuerca
5	3688A034			1	Joint	Articulation	Articulación
6	4128A029			1	Pipe Assy	Ensemble tuyauterie	Tubo, Conj.
7		6	➡ Ref. 6	1	Pipe	Tuyau	Tubo
8	3218R036	6		1	Bolt, Banjo	Raccord Banjo	Perno de banjo
9	2131A506	6		1	Washer	Rondelle	Arandela
10	2131A506	6		1	Washer	Rondelle	Arandela
11	3218R036	6		1	Bolt, Banjo	Raccord Banjo	Perno de banjo
12	2131A506	6		1	Washer	Rondelle	Arandela
13	2131A506	6		1	Washer	Rondelle	Arandela
14	3584A003			1	Pipe Assy	Ensemble tuyauterie	Tubo, Conj.
15	3688A035			1	Joint	Articulation	Articulación
16	3688A036			1	Joint	Articulation	Articulación
17	2314F004			2	Bolt	Boulon	Perno
18	2314J029			1	Screw	Vis	Tornillo
19	2314H003		M8 x 20	2	Screw	Vis	Tornillo
20	3571C072			1	Pipe Assy	Ensemble tuyauterie	Tubo, Conj.
21	3688A037			1	Joint	Articulation	Articulación
22	2314H033			4	Screw	Vis	Tornillo
23	2481D073			1	Clip	Clip	Clip
24	3383A027			1	Hose	Flexible	Tubo flexible
25	2481D073			1	Clip	Clip	Clip
26	2481D314			1	Clip	Clip	Clip



820
TX760B

801 802 803 804 805 806 807 808 831 832 833 834

21010C08.1

6199042M3

1

Jan-06

Engine
Moteur
Motor

Turbocharger Connections
Raccords de Turbocompresseur
Racores de turbocompresor

RG38043
RG38043
RG38043

C-21011-08.1-A

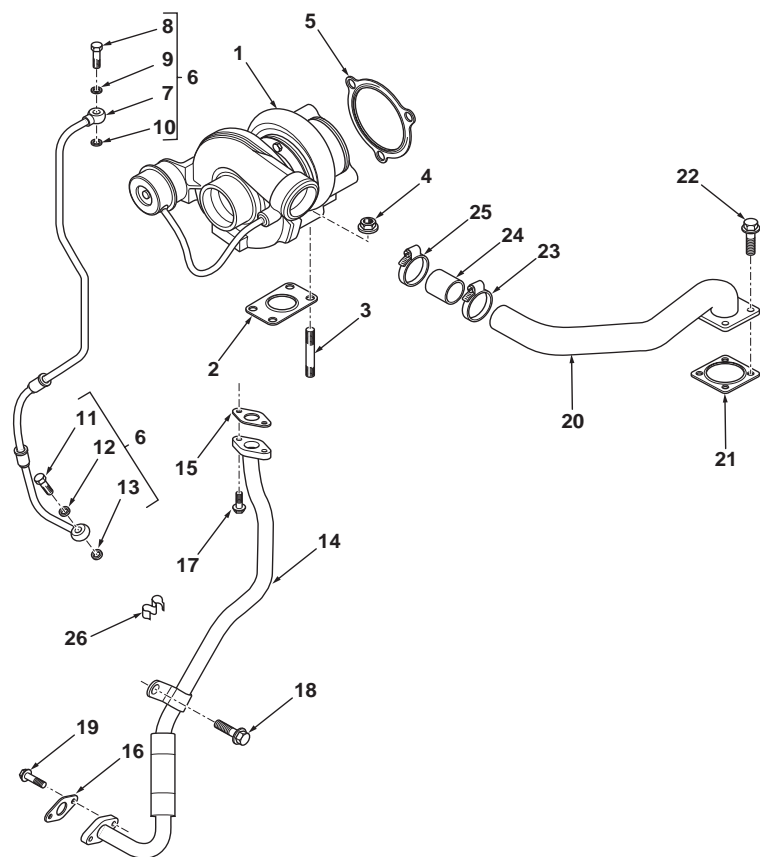

1	2674A226		1	Turbocharger Assy	Ensemble turbocompr.	Turbocompresor, Conj.
2	3688A029		1	Joint	Articulation	Articulación
3	3254K013		4	Stud	Goujon	Espárrago
4	2318A634		4	Nut	Écrou	Tuerca
5	3688A034		1	Joint	Articulation	Articulación
6	4128A029		1	Pipe Assy	Ensemble tuyauterie	Tubo, Conj.
7		6	➡ Ref. 6	Pipe	Tuyau	Tubo
8	3218R036	6	1	Bolt, Banjo	Raccord Banjo	Perno de banjo
9	2131A506	6	1	Washer	Rondelle	Arandela
10	2131A506	6	1	Washer	Rondelle	Arandela
11	3218R036	6	1	Bolt, Banjo	Raccord Banjo	Perno de banjo
12	2131A506	6	1	Washer	Rondelle	Arandela
13	2131A506	6	1	Washer	Rondelle	Arandela
14	3584A003		1	Pipe Assy	Ensemble tuyauterie	Tubo, Conj.
15	3688A035		1	Joint	Articulation	Articulación
16	3688A036		1	Joint	Articulation	Articulación
17	2314F004		2	Bolt	Boulon	Perno
18	2314J029		1	Screw	Vis	Tornillo
19	2314H003	M8 x 20	2	Screw	Vis	Tornillo
20	3571C072		1	Pipe Assy	Ensemble tuyauterie	Tubo, Conj.
21	3688A037		1	Joint	Articulation	Articulación
22	2314H033		4	Screw	Vis	Tornillo
23	2481D073		1	Clip	Clip	Clip
24	3383A027		1	Hose	Flexible	Tubo flexible
25	2481D073		1	Clip	Clip	Clip
26	2481D314		1	Clip	Clip	Clip



820
TX760B

801 803 805 807 831 833

21011C08.1

6199042M3

1

Jan-06

Engine
Moteur
Motor

Turbocharger Connections
Raccords de Turbocompresseur
Racores de turbocompresor

RG38099
RG38099
RG38099

C-21012-08.1-A

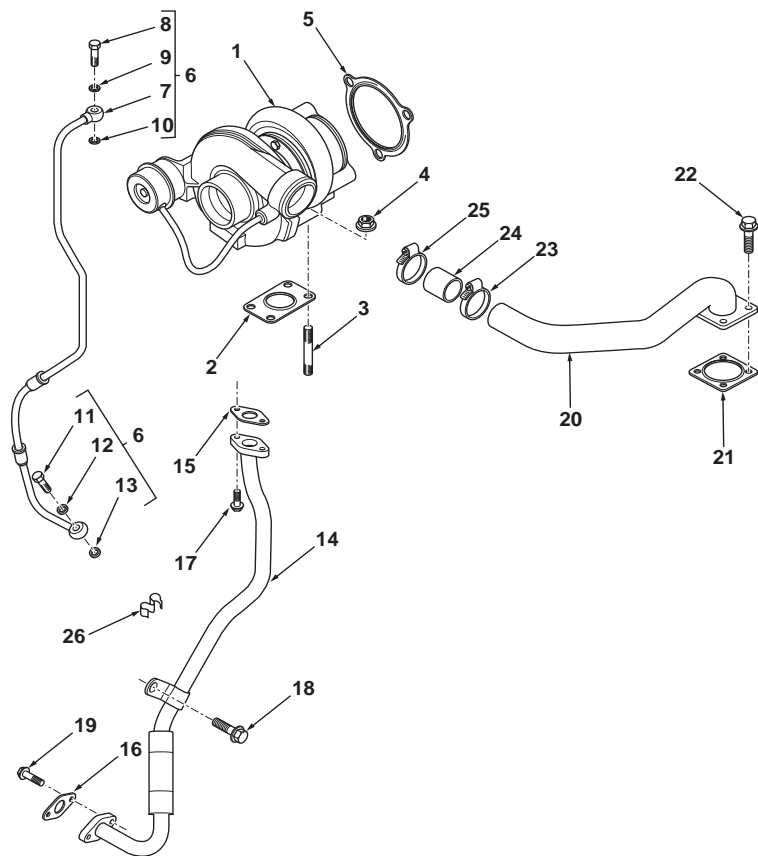

1	2674A226		1	Turbocharger Assy	Ensemble turbocompr.	Turbocompresor, Conj.
2	3688A029		1	Joint	Articulation	Articulación
3	3254K013		4	Stud	Goujon	Espárrago
4	2318A634		4	Nut	Écrou	Tuerca
5	3688A034		1	Joint	Articulation	Articulación
6	4128A029		1	Pipe Assy	Ensemble tuyauterie	Tubo, Conj.
7		6	➡ Ref. 6	Pipe	Tuyau	Tubo
8	3218R036	6	1	Bolt, Banjo	Raccord Banjo	Perno de banjo
9	2131A506	6	1	Washer	Rondelle	Arandela
10	2131A506	6	1	Washer	Rondelle	Arandela
11	3218R036	6	1	Bolt, Banjo	Raccord Banjo	Perno de banjo
12	2131A506	6	1	Washer	Rondelle	Arandela
13	2131A506	6	1	Washer	Rondelle	Arandela
14	3584A003		1	Pipe Assy	Ensemble tuyauterie	Tubo, Conj.
15	3688A035		1	Joint	Articulation	Articulación
16	3688A036		1	Joint	Articulation	Articulación
17	2314F004		2	Bolt	Boulon	Perno
18	2314J029		1	Screw	Vis	Tornillo
19	2314H003	M8 x 20	2	Screw	Vis	Tornillo
20	3571C072		1	Pipe Assy	Ensemble tuyauterie	Tubo, Conj.
21	3688A037		1	Joint	Articulation	Articulación
22	2314H033		4	Screw	Vis	Tornillo
23	2481D073		1	Clip	Clip	Clip
24	3383A027		1	Hose	Flexible	Tubo flexible
25	2481D073		1	Clip	Clip	Clip
26	2481D314		1	Clip	Clip	Clip



860 880 970 980
TX860B TX870B
TX970B

809 810 811 812 813 814 815 816 817 821 822 823 824 825 841 842 843 844 845
851 852 853 854 855 921 922 923 931 932

21012C08.1

6199042M3

1

Jan-06

Engine
Moteur
Motor

Turbocharger Connections
Raccords de Turbocompresseur
Racores de turbocompresor

RG38044
RG38044
RG38044

C-21013-08.1-A

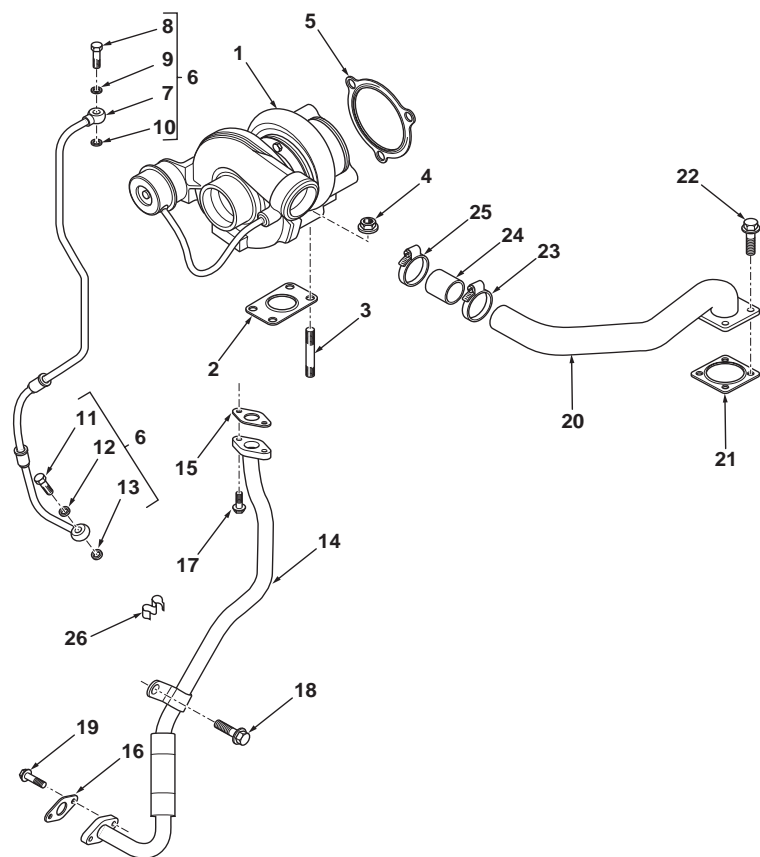

1	2674A226		1	Turbocharger Assy	Ensemble turbocompr.	Turbocompresor, Conj.
2	3688A029		1	Joint	Articulation	Articulación
3	3254K013		4	Stud	Goujon	Espárrago
4	2318A634		4	Nut	Écrou	Tuerca
5	3688A034		1	Joint	Articulation	Articulación
6	4128A029		1	Pipe Assy	Ensemble tuyauterie	Tubo, Conj.
7		6	➡ Ref. 6	Pipe	Tuyau	Tubo
8	3218R036	6	1	Bolt, Banjo	Raccord Banjo	Perno de banjo
9	2131A506	6	1	Washer	Rondelle	Arandela
10	2131A506	6	1	Washer	Rondelle	Arandela
11	3218R036	6	1	Bolt, Banjo	Raccord Banjo	Perno de banjo
12	2131A506	6	1	Washer	Rondelle	Arandela
13	2131A506	6	1	Washer	Rondelle	Arandela
14	3584A003		1	Pipe Assy	Ensemble tuyauterie	Tubo, Conj.
15	3688A035		1	Joint	Articulation	Articulación
16	3688A036		1	Joint	Articulation	Articulación
17	2314F004		2	Bolt	Boulon	Perno
18	2314J029		1	Screw	Vis	Tornillo
19	2314H003	M8 x 20	2	Screw	Vis	Tornillo
20	3571C072		1	Pipe Assy	Ensemble tuyauterie	Tubo, Conj.
21	3688A037		1	Joint	Articulation	Articulación
22	2314H033		4	Screw	Vis	Tornillo
23	2481D073		1	Clip	Clip	Clip
24	3383A027		1	Hose	Flexible	Tubo flexible
25	2481D073		1	Clip	Clip	Clip
26	2481D314		1	Clip	Clip	Clip



860 880 970 980
TX860B TX870B
TX970B

809 811 813 815 817 821 823 825 841 843 845 851 853 855 921 922 923 931 932

21013C08.1

6199042M3

1

Jan-06

Engine
Moteur
Motor

Water Pump
Pompe à Eau
Bomba de agua

RG38100
RG38100
RG38100

C-21010-11.1-A

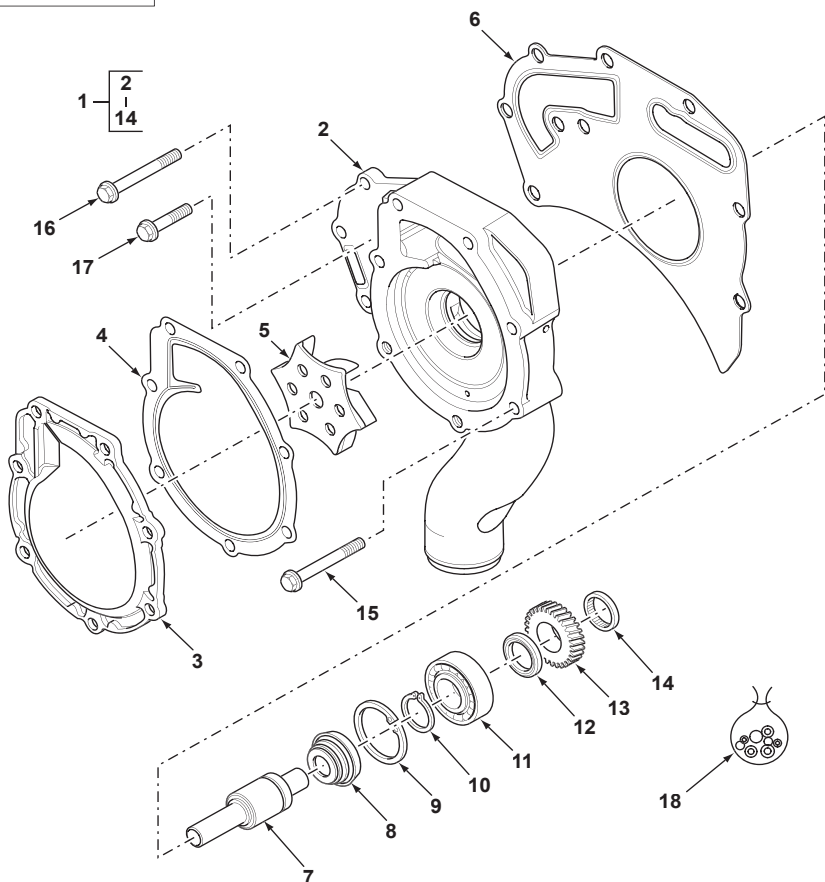

1	U5MW0194			1	Pump, Water	Pompe à eau	Bomba de agua
2		1	➤ Ref. 1	1	Body	Corps	Cuerpo
3		1	➤ Ref. 1	1	Cover	Cache	Tapa
4		1	(A)	1	Gasket	Joint	Empaquetadura
5		1	(A)	1	Turbine	Turbine	Turbina
6	3682A011	1	(A)	1	Joint	Articulation	Articulación
7		1	(A)	1	Shaft	Arbre	Árbol
8		1	(A)	1	Seal	Joint	Junta
9		1	(A)	1	Clip	Clip	Clip
10		1	(A)	1	Clip	Clip	Clip
11		1	(A)	1	Bearing	Coussinet	Cojinete
12		1	(A)	1	Seal	Joint	Junta
13	24880232	1		1	Gear	Pignon	Piñón
14		1	(A)	1	Bearing	Coussinet	Cojinete
15	2314H012			5	Screw	Vis	Tornillo
16	2314K164			2	Screw	Vis	Tornillo
17	2314H005	M8 x 30		2	Screw	Vis	Tornillo
18	U7LW0172	(B)		1	Kit, Service	Kit d'entretien	Juego de servicio

A Included in kit marked (B)
Inclus dans jeu marqué (B)
Incluido en juego marcado (B)

B Contains items marked (A)
Comprend les pièces marquées (A)
Incluye las piezas marcadas (A)



820
TX760B

801 802 803 804 805 806 807 808 831 832 833 834

21010C11.1

6199042M3

1

Jan-06

Engine
Moteur
Motor

Water Pump
Pompe à Eau
Bomba de agua

RG38043
RG38043
RG38043

C-21011-11.1-A

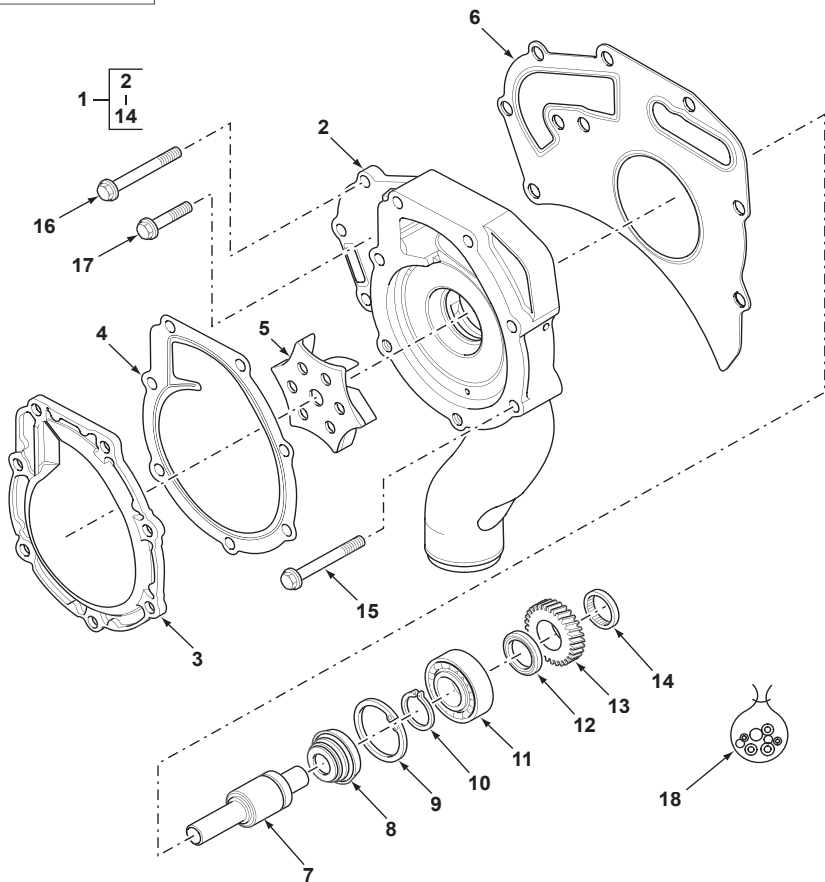

1	U5MW0194			1	Pump, Water	Pompe à eau	Bomba de agua
2		1	▶ Ref. 1	1	Body	Corps	Cuerpo
3		1	▶ Ref. 1	1	Cover	Cache	Tapa
4		1	(A)	1	Gasket	Joint	Empaquetadura
5		1	(A)	1	Turbine	Turbine	Turbina
6	3682A011	1	(A)	1	Joint	Articulation	Articulación
7		1	(A)	1	Shaft	Arbre	Árbol
8		1	(A)	1	Seal	Joint	Junta
9		1	(A)	1	Clip	Clip	Clip
10		1	(A)	1	Clip	Clip	Clip
11		1	(A)	1	Bearing	Coussinet	Cojinete
12		1	(A)	1	Seal	Joint	Junta
13	24880232	1		1	Gear	Pignon	Piñón
14		1	(A)	1	Bearing	Coussinet	Cojinete
15	2314H012			5	Screw	Vis	Tornillo
16	2314K164			2	Screw	Vis	Tornillo
17	2314H005	M8 x 30		2	Screw	Vis	Tornillo
18	U7LW0172	(B)		1	Kit, Service	Kit d'entretien	Juego de servicio

A Included in kit marked (B)
Inclus dans jeu marqué (B)
Incluido en juego marcado (B)

B Contains items marked (A)
Comprend les pièces marquées (A)
Incluye las piezas marcadas (A)



820
TX760B

801 803 805 807 831 833

21011C11.1

6199042M3

1

Jan-06

Engine
Moteur
Motor

Water Pump
Pompe à Eau
Bomba de agua

RG38099
RG38099
RG38099

C-21012-11.1-A

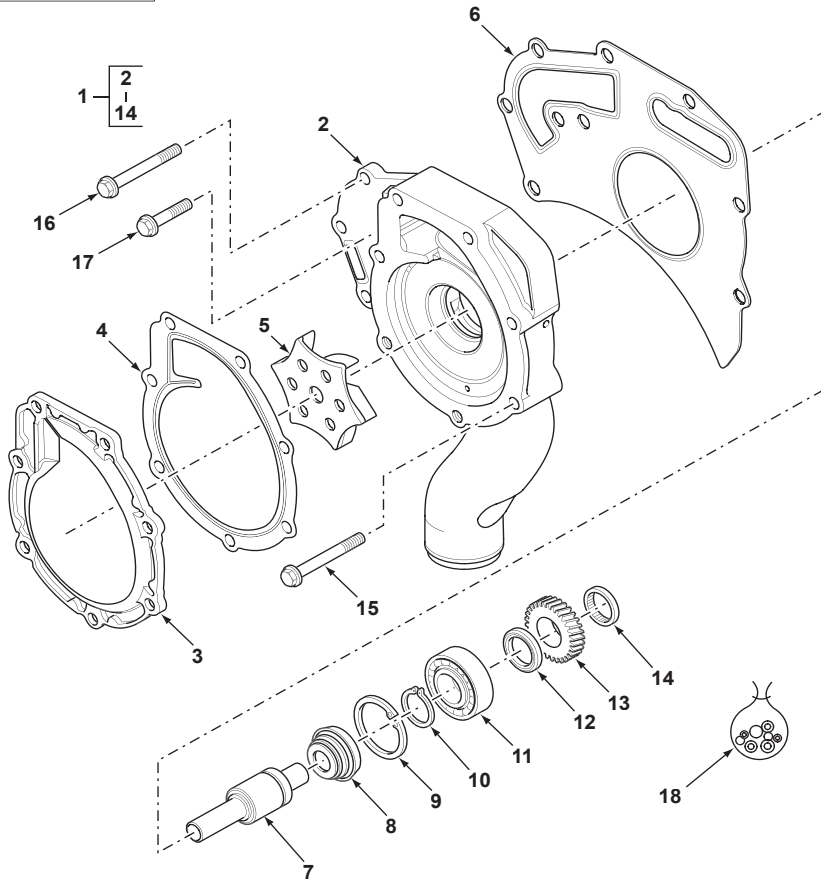

1	U5MW0194			1	Pump, Water	Pompe à eau	Bomba de agua
2		1	Ref. 1	1	Body	Corps	Cuerpo
3		1	Ref. 1	1	Cover	Cache	Tapa
4		1	(A)	1	Gasket	Joint	Empaquetadura
5		1	(A)	1	Turbine	Turbine	Turbina
6	3682A011	1	(A)	1	Joint	Articulation	Articulación
7		1	(A)	1	Shaft	Arbre	Árbol
8		1	(A)	1	Seal	Joint	Junta
9		1	(A)	1	Clip	Clip	Clip
10		1	(A)	1	Clip	Clip	Clip
11		1	(A)	1	Bearing	Coussinet	Cojinete
12		1	(A)	1	Seal	Joint	Junta
13	24880232	1		1	Gear	Pignon	Piñón
14		1	(A)	1	Bearing	Coussinet	Cojinete
15	2314H012			5	Screw	Vis	Tornillo
16	2314K164			2	Screw	Vis	Tornillo
17	2314H005	M8 x 30		2	Screw	Vis	Tornillo
18	U7LW0172	(B)		1	Kit, Service	Kit d'entretien	Juego de servicio

A Included in kit marked (B)
Inclus dans jeu marqué (B)
Incluido en juego marcado (B)

B Contains items marked (A)
Comprend les pièces marquées (A)
Incluye las piezas marcadas (A)



860 880 970 980
TX860B TX870B
TX970B

809 810 811 812 813 814 815 816 817 821 822 823 824 825 841 842 843 844 845
851 852 853 854 855 921 922 923 931 932

21012C11.1

6199042M3

1

Jan-06

Engine
Moteur
Motor

Water Pump
Pompe à Eau
Bomba de agua

RG38044
RG38044
RG38044

C-21013-11.1-A

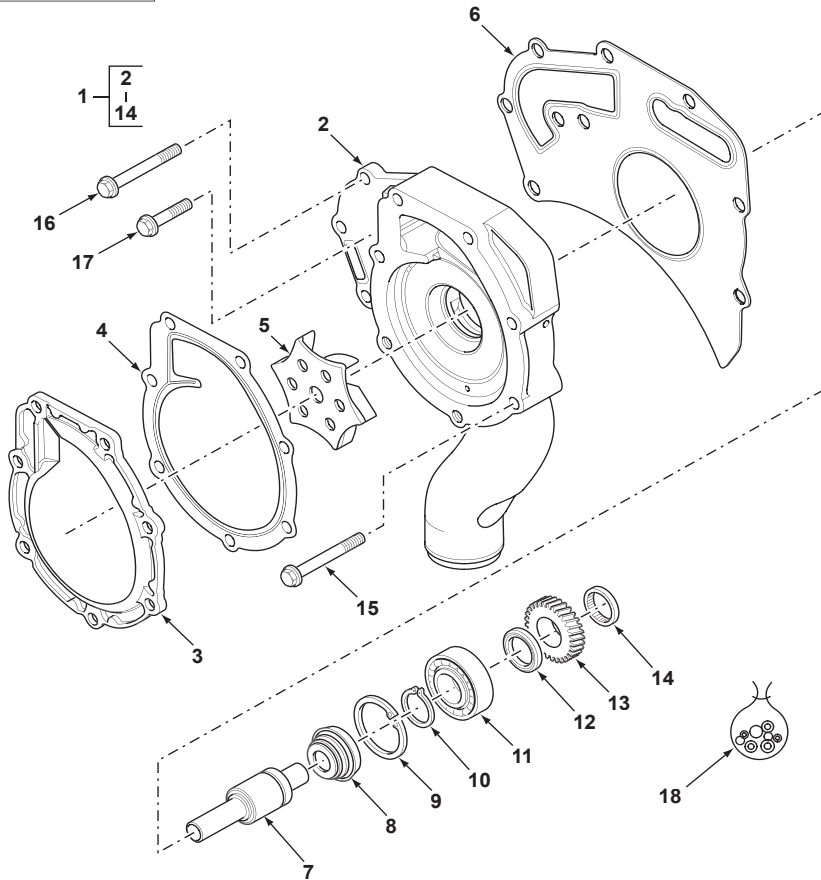

1	U5MW0194			1	Pump, Water	Pompe à eau	Bomba de agua
2		1	▶ Ref. 1	1	Body	Corps	Cuerpo
3		1	▶ Ref. 1	1	Cover	Cache	Tapa
4		1	(A)	1	Gasket	Joint	Empaquetadura
5		1	(A)	1	Turbine	Turbine	Turbina
6	3682A011	1	(A)	1	Joint	Articulation	Articulación
7		1	(A)	1	Shaft	Arbre	Árbol
8		1	(A)	1	Seal	Joint	Junta
9		1	(A)	1	Clip	Clip	Clip
10		1	(A)	1	Clip	Clip	Clip
11		1	(A)	1	Bearing	Coussinet	Cojinete
12		1	(A)	1	Seal	Joint	Junta
13	24880232	1		1	Gear	Pignon	Piñón
14		1	(A)	1	Bearing	Coussinet	Cojinete
15	2314H012			5	Screw	Vis	Tornillo
16	2314K164			2	Screw	Vis	Tornillo
17	2314H005	M8 x 30		2	Screw	Vis	Tornillo
18	U7LW0172	(B)		1	Kit, Service	Kit d'entretien	Juego de servicio

A Included in kit marked (B)
Inclus dans jeu marqué (B)
Incluido en juego marcado (B)

B Contains items marked (A)
Comprend les pièces marquées (A)
Incluye las piezas marcadas (A)



860 880 970 980
TX860B TX870B
TX970B

809 811 813 815 817 821 823 825 841 843 845 851 853 855 921 922 923 931 932

21013C11.1

6199042M3

1

Jan-06

Exhaust System
Échappement
Escape

C-23010-01.1-A

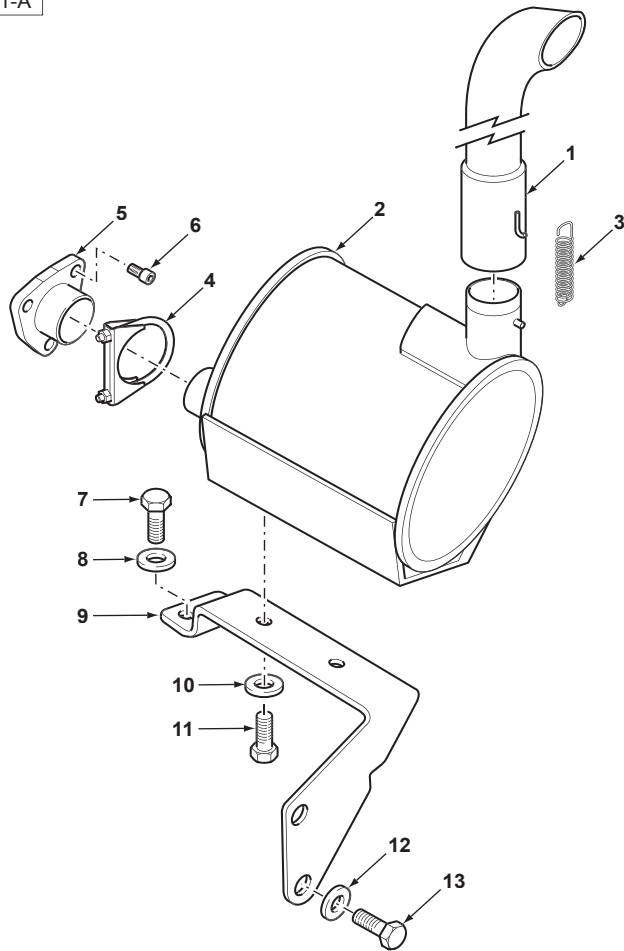

1	6109178M91		1	Pipe, Exhaust	Pot d'échappement	Tubo de escape
2	6110098M91		1	Silencer	Silencieux	Silenciador
3	3522399M1		1	Spring	Ressort	Muelle
4	1696972M91		1	Clamp	Collier de serrage	Argolla de cierre
5	6110102M1		1	Adaptor	Adaptateur	Adaptador
6	3009292X1	M10 x 25	3	Screw	Vis	Tornillo
7	339761X1	M8 x 25	2	Screw	Vis	Tornillo
8	385361X1	M8	2	Washer	Rondelle	Arandela
9	6110101M1		1	Support	Support	Soporte
10	385362X1	M10	2	Washer	Rondelle	Arandela
11	3009492X1	M10 x 25	2	Screw	Vis	Tornillo
12	385362X1	M10	2	Washer	Rondelle	Arandela
13	3009493X1	M10 x 30	2	Bolt	Boulon	Perno



820 860 880 970 980
TX760B TX860B
TX870B TX970B

801 802 803 804 805 806 807 808 809 810 811 812 813 814 815 816 817 821 822
823 824 825 831 832 833 834 841 842 843 844 845 851 852 853 854 855 921 922
923 931 932

23010C01.1

6199042M3

1

Jan-06

Fuel System
Circuit de Carburant
Circuito combustible

C-22004-01.1-A

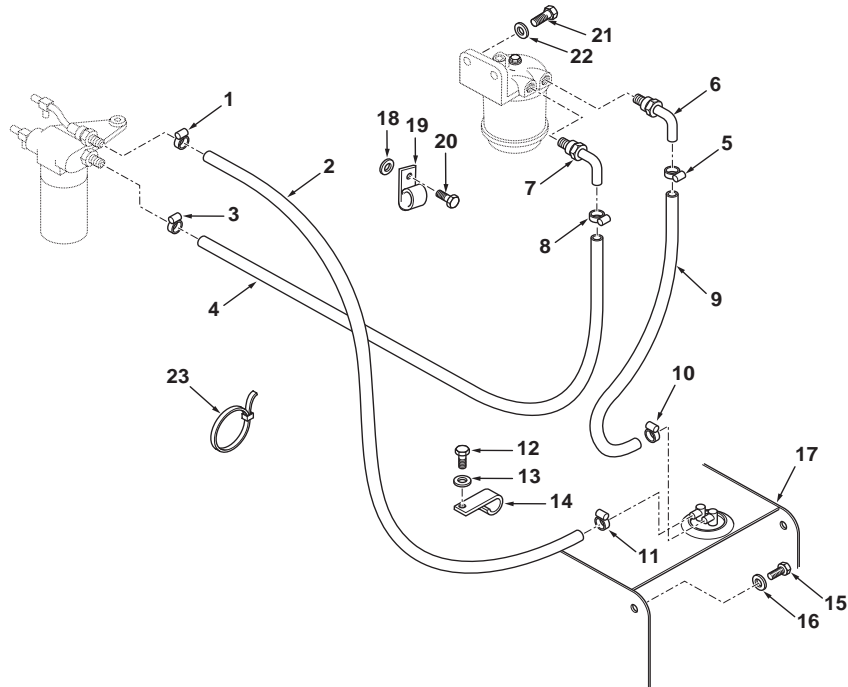

1	6013102M1		1	Clip	Clip	Clip
2	6110209M1		1	Hose	Flexible	Tubo flexible
3	6013102M1		1	Clip	Clip	Clip
4	6110208M3		1	Hose	Flexible	Tubo flexible
5	6013102M1		1	Clip	Clip	Clip
6	6109741M91		1	Tube Assy	Tuyauterie	Conjunto de tubería
7	6109741M91		1	Tube Assy	Tuyauterie	Conjunto de tubería
8	6013102M1		1	Clip	Clip	Clip
9	6110376M2		1	Hose	Flexible	Tubo flexible
10	6013102M1		1	Clip	Clip	Clip
11	6013102M1		1	Clip	Clip	Clip
12	339228X1	M8 x 12	1	Screw	Vis	Tornillo
13	390972X1	M8	2	Washer	Rondelle	Arandela
14	3522812M1		2	Bracket, Clamp	Bride de fixation	Brida de fijación
15	3009505X1	M12 x 25	4	Bolt	Boulon	Perno
16	391212X1	M12	4	Washer	Rondelle	Arandela
17	6109805M92	22004C02.1 1	1	Tank, Fuel	Réservoir de carburant	Dépositó combustible
18	385362X1	M10	1	Washer	Rondelle	Arandela
19	3522812M1		1	Bracket, Clamp	Bride de fixation	Brida de fijación
20	339282X1	M10 x 16	1	Screw	Vis	Tornillo
21	3009492X1	M10 x 25	2	Screw	Vis	Tornillo
22	385362X1	M10	2	Washer	Rondelle	Arandela
23	1862425M1		6	Tie, Cable	Attache câble	Enlace de Cable



820 860 880 970 980
 TX760B TX860B
 TX870B TX970B

801 802 803 804 805 806 807 808 809 810 811 812 813 814 815 816 817 821 822
 823 824 825 831 832 833 834 841 842 843 844 845 851 852 853 854 855 921 922
 923 931 932

22004C01.1

6199042M3

1

Jan-06

Fuel System
Circuit de Carburant
Circuito combustible

Fuel Tank
Réservoir de Carburant
Depósito de combustible

C-22004-02.1-A

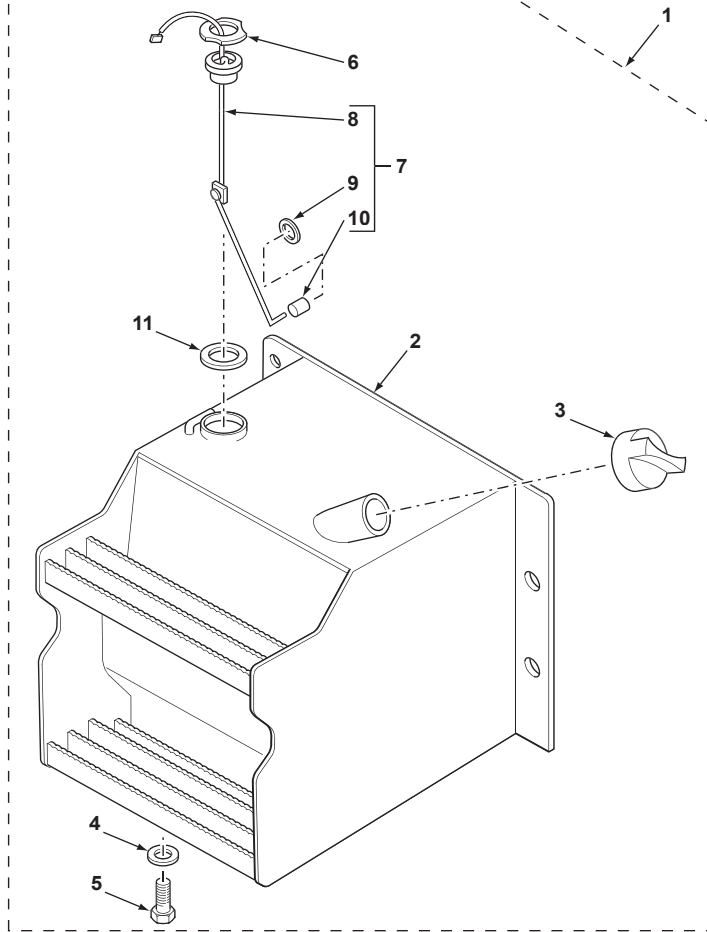

1	6109805M92	22004C01.1 17	1	Tank, Fuel	Réservoir de carburant	Depósito combustible
2		Ref. 1	1	Tank, Fuel	Réservoir de carburant	Depósito combustible
3	6101316M91		1	Cap, Filler	Bouchon rempliss.	Tapón de llenado
4	1476281X1		1	Ring, Packing	Rondelle joint	Arandela junta
5	376501X1		1	Plug, Drain	Bouchon de vidange	Tapón de drenaje
6	1694979M1		1	Ring, Sealing	Bague d'étanchéité	Anillo, Estanqueidad
7	6109152M91		1	Gauge, Fuel	Jauge de carburant	Calibre de combustible
8		Ref. 7	1	Gauge	Jauge	Calibre
9		Ref. 7	1	Ring	Anneau	Aro
10		Ref. 7	1	Float	Flotteur	Flotador
11	1694980M1		1	Ring, Sealing	Bague d'étanchéité	Anillo, Estanqueidad



820 860 880 970 980
 TX760B TX860B
 TX870B TX970B

801 802 803 804 805 806 807 808 809 810 811 812 813 814 815 816 817 821 822
 823 824 825 831 832 833 834 841 842 843 844 845 851 852 853 854 855 921 922
 923 931 932

22004C02.1

6199042M3

1

Jan-06

Induction System
Induction
Sistema de inducción

Air Filter
Filtre à Air
Filtro aire

C-24010-02.1-A

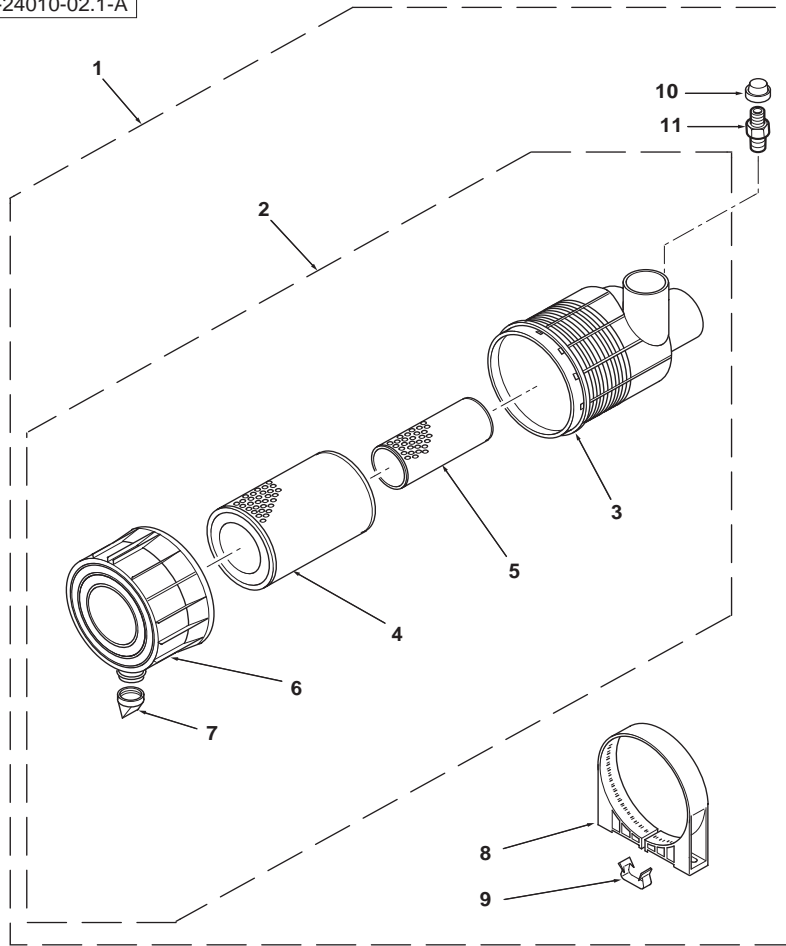

1	6107336M91		24010C01.1 6	1	Air Cleaner Assy	Ensemble filtre à air	Filtro de aire, Conj.
2	6190630M92	1		1	Body Assy	Ensemble de corps	Cuerpo, Conj.
3		2	Ref. 2	1	Body	Corps	Cuerpo
4	6190627M1	2	Main	1	Element, Filter	Élément filtrant	Elemento filtrante
5	6190628M1	2	Safety	1	Element, Filter	Élément filtrant	Elemento filtrante
6	6190654M91	2		1	Cover, Filter	Couvercle de filtre	Tapa de filtro
7	6193599M91	2		1	Valve	Soupape	Válvula
8	6193600M1	1		1	Clip, Mounting	Collier de fixation	Argolla de fijación
9	6193609M1	1		2	Clip	Clip	Clip
10	3595498M1	1		1	Indicator	Témoin	Indicador
11	6190653M1	1		1	Fitting	Raccord	Racor



820 860 880 970 980
TX760B TX860B
TX870B TX970B

801 802 803 804 805 806 807 808 809 810 811 812 813 814 815 816 817 821 822
823 824 825 831 832 833 834 841 842 843 844 845 851 852 853 854 855 921 922
923 931 932

24010C02.1

6199042M3

1

Jan-06

Induction System
Induction
Sistema de inducción

Air Filter
Filtre à Air
Filtro aire

C-24011-02.1-A

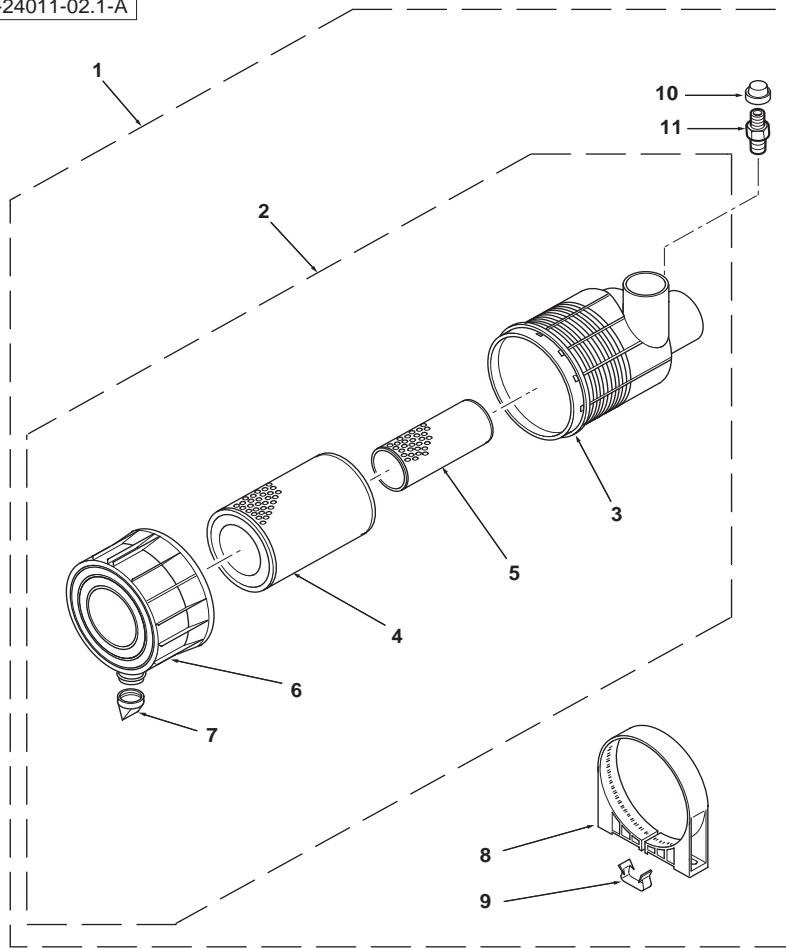

1	6107336M91		👁 24011C01.1 8	1	Air Cleaner Assy	Ensemble filtre à air	Filtro de aire, Conj.
2	6190630M92	1		1	Body Assy	Ensemble de corps	Cuerpo, Conj.
3		2	🔪 Ref. 2	1	Body	Corps	Cuerpo
4	6190627M1	2	Main	1	Element, Filter	Élément filtrant	Elemento filtrante
5	6190628M1	2	Safety	1	Element, Filter	Élément filtrant	Elemento filtrante
6	6190654M91	2		1	Cover, Filter	Couvercle de filtre	Tapa de filtro
7	6193599M91	2		1	Valve	Soupape	Válvula
8	6193600M1	1		1	Clip, Mounting	Collier de fixation	Argolla de fijación
9	6193609M1	1		2	Clip	Clip	Clip
10	3595498M1	1		1	Indicator	Témoin	Indicador
11	6190653M1	1		1	Fitting	Raccord	Racor



820 860 880 970 980
TX760B TX860B
TX870B TX970B

801 802 803 804 805 806 807 808 809 810 811 812 813 814 815 816 817 821 822
823 824 825 831 832 833 834 841 842 843 844 845 851 852 853 854 855 921 922
923 931 932

24011C02.1

6199042M3

1

Jan-06

Induction System
Induction
Sistema de inducción

Air Filtration
Filtration Air
Filtración aire

C-24010-01.1-B

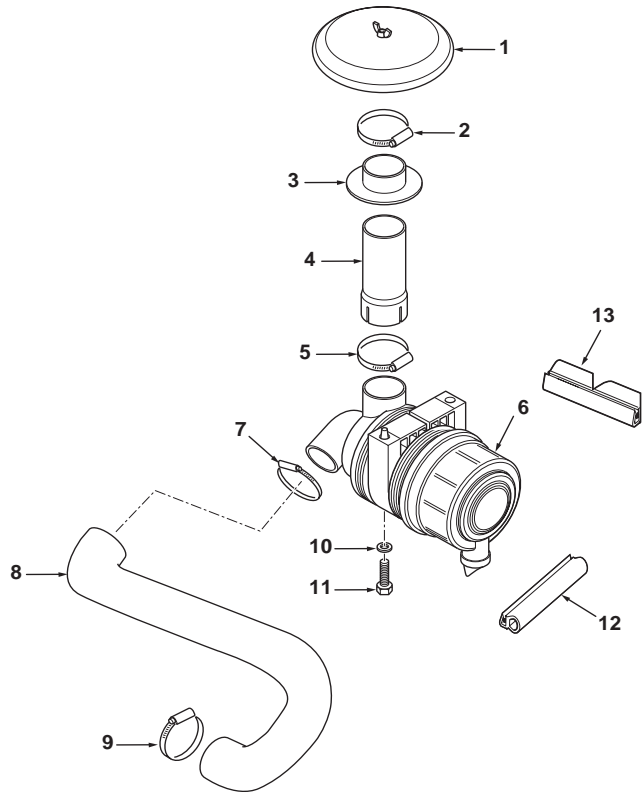

1	6003555M1			1	Cap	Chapeau	Sombreroete
2	3517729M1			1	Collar	Collier	Collar
3	6003409M1			1	Seal	Joint	Junta
4	6108477M1			1	Tube, Air	Chambre à air	Cámara de aire
5	3517729M1			1	Collar	Collier	Collar
6	6107336M91	☉ 24010C02.1 1		1	Air Cleaner Assy	Ensemble filtre à air	Filtro de aire, Conj.
7	3517729M1			1	Collar	Collier	Collar
8	6110103M2			1	Hose	Flexible	Tubo flexible
9	3517415M1			1	Collar	Collier	Collar
10	390972X1	M8		2	Washer	Rondelle	Arandela
11	339761X1	M8 x 25		2	Screw	Vis	Tornillo
12	6110471M1	Front		1	Seal	Joint	Junta
13	6110472M1	Rear		1	Seal	Joint	Junta



820 860 880 970 980
TX760B TX860B
TX870B TX970B

801 802 803 804 805 806 807 808 809 810 811 812 813 814 815 816 817 821 822
823 824 825 831 832 833 834 841 842 843 844 845 851 852 853 854 855 921 922
923 931 932

24010C01.1

6199042M3

1

Jan-06

Induction System
Induction
Sistema de inducción

Air Filtration
Filtration Air
Filtración aire

With Pre Cleaner
Avec Coffret de Filtre à Air
Con de filtros

C-24011-01.1-B

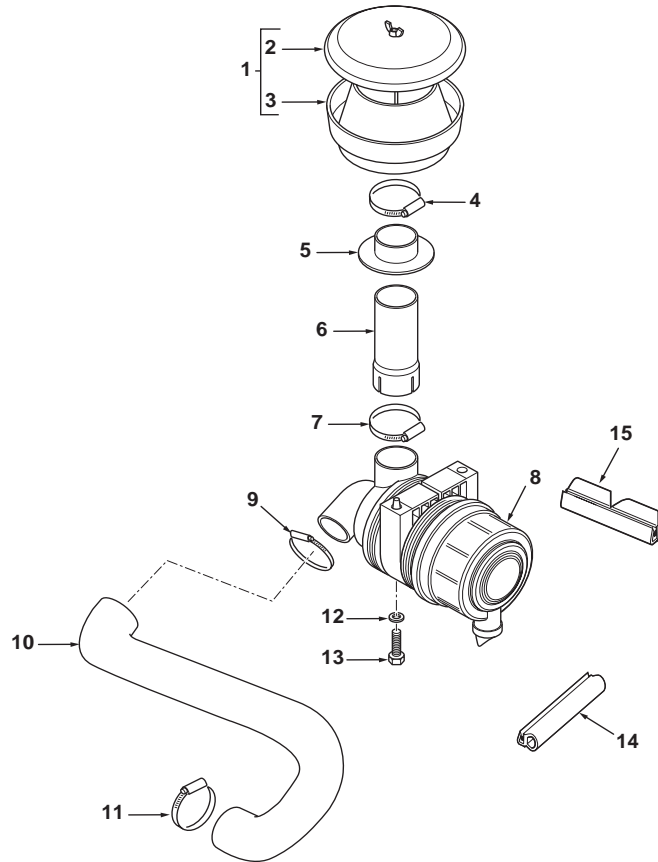

1	6100634M91		1	Cleaner Assy	Filtre à air, montage	Filtro, Conj.
2		1	▶ Ref. 1	Cover	Cache	Tapa
3		1	▶ Ref. 1	Bowl	Cuve	Cuba
4	3517729M1			Collar	Collier	Collar
5	6003409M1			Seal	Joint	Junta
6	6108477M1			Tube, Air	Chambre à air	Cámara de aire
7	3517729M1			Collar	Collier	Collar
8	6107336M91	● 24011C02.1	1	Air Cleaner Assy	Ensemble filtre à air	Filtro de aire, Conj.
9	3517729M1			Collar	Collier	Collar
10	6110103M2			Hose	Flexible	Tubo flexible
11	3517415M1			Collar	Collier	Collar
12	390972X1	M8	2	Washer	Rondelle	Arandela
13	339761X1	M8 x 25	2	Screw	Vis	Tornillo
14	6110471M1	Front	1	Seal	Joint	Junta
15	6110472M1	Rear	1	Seal	Joint	Junta



820 860 880 970 980
TX760B TX860B
TX870B TX970B

801 802 803 804 805 806 807 808 809 810 811 812 813 814 815 816 817 821 822
823 824 825 831 832 833 834 841 842 843 844 845 851 852 853 854 855 921 922
923 931 932

24011C01.1

6199042M3

1

Jan-06

Throttle Controls
Accélérateur
Acelerador

C-42003-01.1-B

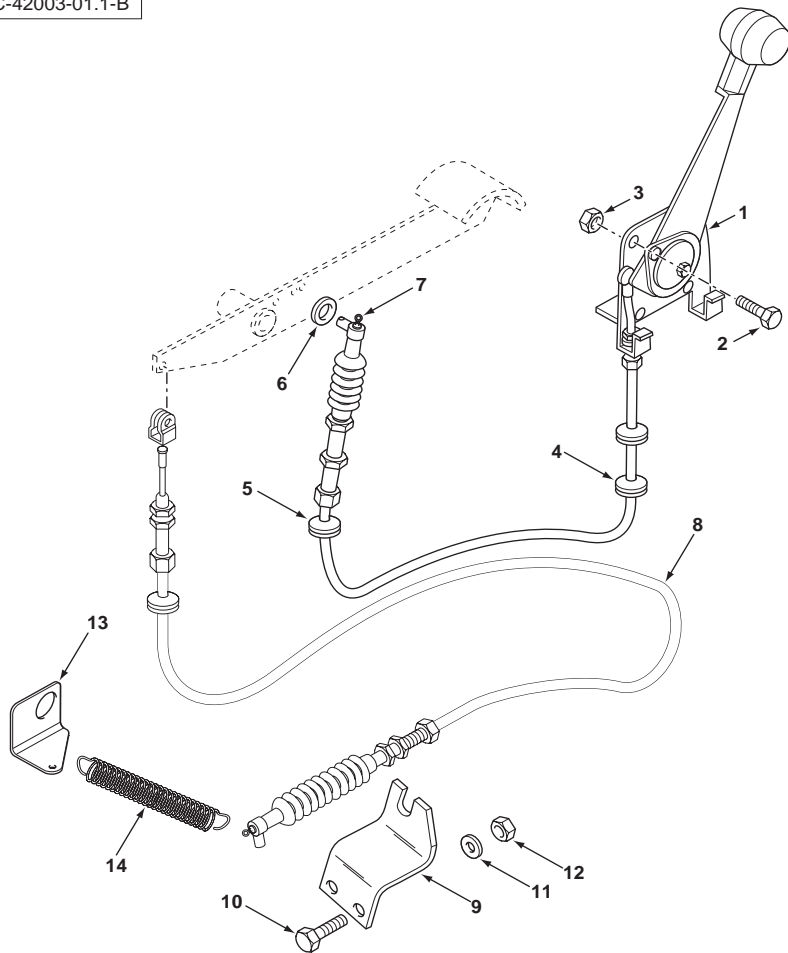

1	6100620M91	42003C02.1	1	Control Assy	Ensemble commande	Mando, Conj.
2	3009667X1	M5 x 30	4	Screw	Vis	Tornillo
3	390995X1	M5	4	Nut	Écrou	Tuerca
4	6101552M1		1	Grommet	Passe-fil	Pasa cable
5	6102367M1		1	Grommet	Passe-fil	Pasa cable
6	390971X1	M6	1	Washer	Rondelle	Arandela
7	3517074M1		2	Pin, Split	Goupille	Pasador
8		41010C02.1	34	Cable	Câble	Cable
9	6109751M1		1	Bracket	Patte de fixation	Pata de fijación
10	339804X1	M6 x 25	2	Screw	Vis	Tornillo
11	390971X1	M6	2	Washer	Rondelle	Arandela
12	1441500X1	M6	2	Nut, Lock	Écrou de blocage	Tuerca de retención
13	297985A1		1	Plate	Plaque	Placa
14	297987A1		1	Spring	Ressort	Muelle



820 860 880 970 980
 TX760B TX860B
 TX870B TX970B

801 802 803 804 805 806 807 808 809 810 811 812 813 814 815 816 817 821 822
 823 824 825 831 832 833 834 841 842 843 844 845 851 852 853 854 855 921 922
 923 931 932

42003C01.1

6199042M3

1

Jan-06

Throttle Controls
Accélérateur
Acelerador

Lever, Control
 Levier de Commande
 Palanca de mando

C-42003-02.1-A

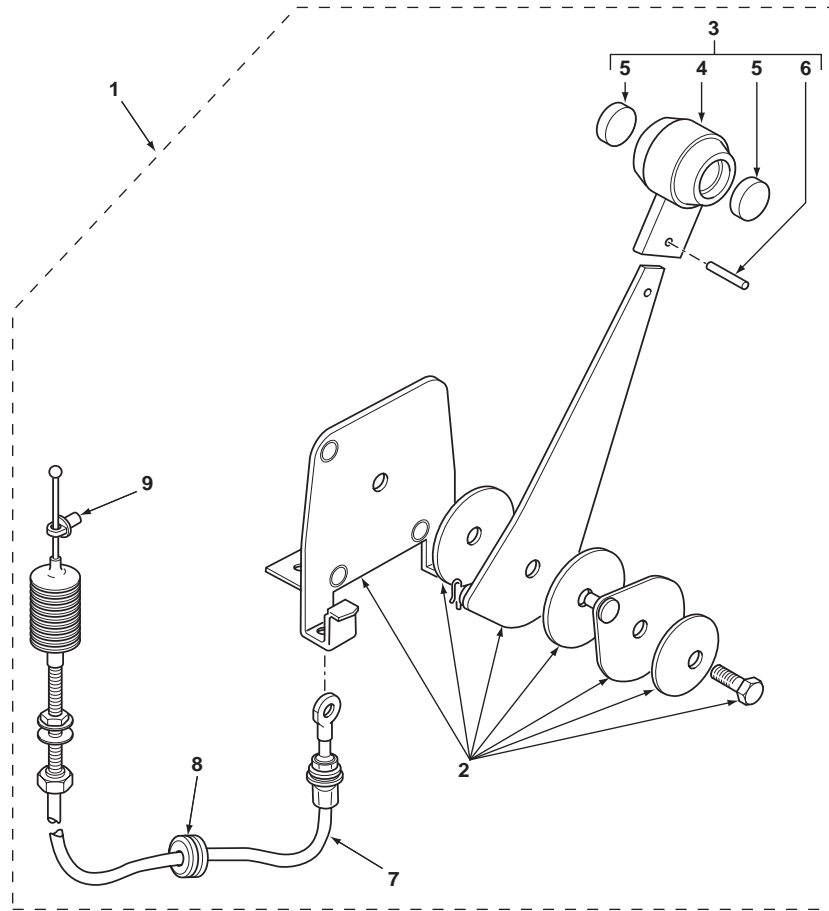

1	6100620M91		42003C01.1	1	Control Assy	Ensemble commande	Mando, Conj.
2	6190736M91	1		1	Lever, Control	Levier de commande	Palanca de mando
3	6190737M91	1		1	Handle Assy	Ensemble de poignée	Empuñadura, Conj.
4		3	Ref. 3	1	Handle	Poignée	Asa
5		3	Ref. 3	2	Cover	Cache	Tapa
6		3	Ref. 3	1	Pin	Axe	Pasador
7	6190738M91	1		1	Cable	Câble	Cable
8	3522134M2	1		1	Grommet	Passe-fil	Pasa cable
9	3517932M1	1		1	Pivot, Swivel	Pivot joint tournant	Pivote junta giratoria



820 860 880 970 980
 TX760B TX860B
 TX870B TX970B

801 802 803 804 805 806 807 808 809 810 811 812 813 814 815 816 817 821 822
 823 824 825 831 832 833 834 841 842 843 844 845 851 852 853 854 855 921 922
 923 931 932

42003C02.1

6199042M3

1

Jan-06

Q - Legal Requirements • Obligations légales • Requisitos legales

Decals - Craning Valve Kit.....	95019C01.1	Adhésifs - Coffret de Distributeur de Commande Manutention	Adhesivos - Juego de distribuidor de mando de mantenimiento
Decals - Craning Valve Kit.....	95020C01.1	Adhésifs - Coffret de Distributeur de Commande Manutention	Adhesivos - Juego de distribuidor de mando de mantenimiento
Decals - Craning Valve Kit.....	95021C01.1	Adhésifs - Coffret de Distributeur de Commande Manutention	Adhesivos - Juego de distribuidor de mando de mantenimiento
Decals - Instructions	93001C02.1	Adhésifs - Instructions	Adhesivos - Instrucciones
Decals - Instructions	93002C02.1	Adhésifs - Instructions	Adhesivos - Instrucciones
Decals - Instructions	93003C02.1	Adhésifs - Instructions	Adhesivos - Instrucciones
Decals - Instructions	93004C02.1	Adhésifs - Instructions	Adhesivos - Instrucciones
Decals - Instructions	93005C02.1	Adhésifs - Instructions	Adhesivos - Instrucciones
Decals - Instructions	93006C02.1	Adhésifs - Instructions	Adhesivos - Instrucciones
Decals - Instructions	93007C02.1	Adhésifs - Instructions	Adhesivos - Instrucciones
Decals - Instructions	93008C02.1	Adhésifs - Instructions	Adhesivos - Instrucciones
Decals - Instructions	93009C02.1	Adhésifs - Instructions	Adhesivos - Instrucciones
Decals - Instructions	93010C02.1	Adhésifs - Instructions	Adhesivos - Instrucciones
Decals - Instructions	93011C02.1	Adhésifs - Instructions	Adhesivos - Instrucciones
Decals - Instructions	93012C02.1	Adhésifs - Instructions	Adhesivos - Instrucciones
Decals - Instructions	93013C02.1	Adhésifs - Instructions	Adhesivos - Instrucciones
Decals - Instructions	93014C02.1	Adhésifs - Instructions	Adhesivos - Instrucciones
Decals - Instructions	93015C02.1	Adhésifs - Instructions	Adhesivos - Instrucciones
Decals - Instructions	93016C02.1	Adhésifs - Instructions	Adhesivos - Instrucciones
Decals - Instructions	93017C02.1	Adhésifs - Instructions	Adhesivos - Instrucciones
Decals - Instructions	93018C02.1	Adhésifs - Instructions	Adhesivos - Instrucciones
Decals - Instructions	93020C02.1	Adhésifs - Instructions	Adhesivos - Instrucciones
Decals - Instructions	93021C02.1	Adhésifs - Instructions	Adhesivos - Instrucciones
Decals - Instructions	93022C02.1	Adhésifs - Instructions	Adhesivos - Instrucciones
Decals - Instructions	93023C02.1	Adhésifs - Instructions	Adhesivos - Instrucciones
Decals - Machine Identity	92001C01.1	Adhésifs - Identification Machine	Adhesivos - Identificación de máquina
Decals - Machine Identity	92002C01.1	Adhésifs - Identification Machine	Adhesivos - Identificación de máquina
Decals - Machine Identity	92003C01.1	Adhésifs - Identification Machine	Adhesivos - Identificación de máquina
Decals - Machine Identity	92004C01.1	Adhésifs - Identification Machine	Adhesivos - Identificación de máquina
Decals - Machine Identity	92005C01.1	Adhésifs - Identification Machine	Adhesivos - Identificación de máquina
Decals - Machine Identity	92006C01.1	Adhésifs - Identification Machine	Adhesivos - Identificación de máquina
Decals - Machine Identity	92007C01.1	Adhésifs - Identification Machine	Adhesivos - Identificación de máquina
Decals - Machine Identity	92009C01.1	Adhésifs - Identification Machine	Adhesivos - Identificación de máquina
Decals - Machine Identity	92010C01.1	Adhésifs - Identification Machine	Adhesivos - Identificación de máquina
Decals - Machine Identity	92011C01.1	Adhésifs - Identification Machine	Adhesivos - Identificación de máquina
Decals - Machine Identity	92012C01.1	Adhésifs - Identification Machine	Adhesivos - Identificación de máquina
Decals - Machine Identity	92015C01.1	Adhésifs - Identification Machine	Adhesivos - Identificación de máquina
Decals - Machine Identity	92016C01.1	Adhésifs - Identification Machine	Adhesivos - Identificación de máquina



Q - Legal Requirements • Obligations légales • Requisitos legales

Decals - Machine Identity	92017C01.1	Adhésifs - Identification Machine	Adhesivos - Identificación de máquina
Decals - Machine Identity	92018C01.1	Adhésifs - Identification Machine	Adhesivos - Identificación de máquina
Decals - Machine Identity	92019C01.1	Adhésifs - Identification Machine	Adhesivos - Identificación de máquina
Decals - Machine Identity	92020C01.1	Adhésifs - Identification Machine	Adhesivos - Identificación de máquina
Decals - Machine Identity	92024C01.1	Adhésifs - Identification Machine	Adhesivos - Identificación de máquina
Decals - Miscellaneous.....	93001C03.1	Adhésifs - Divers	Adhesivos - Varios
Decals - Miscellaneous.....	93002C03.1	Adhésifs - Divers	Adhesivos - Varios
Decals - Miscellaneous.....	93003C03.1	Adhésifs - Divers	Adhesivos - Varios
Decals - Miscellaneous.....	93004C03.1	Adhésifs - Divers	Adhesivos - Varios
Decals - Miscellaneous.....	93005C03.1	Adhésifs - Divers	Adhesivos - Varios
Decals - Miscellaneous.....	93006C03.1	Adhésifs - Divers	Adhesivos - Varios
Decals - Miscellaneous.....	93007C03.1	Adhésifs - Divers	Adhesivos - Varios
Decals - Miscellaneous.....	93008C03.1	Adhésifs - Divers	Adhesivos - Varios
Decals - Miscellaneous.....	93009C03.1	Adhésifs - Divers	Adhesivos - Varios
Decals - Miscellaneous.....	93010C03.1	Adhésifs - Divers	Adhesivos - Varios
Decals - Miscellaneous.....	93011C03.1	Adhésifs - Divers	Adhesivos - Varios
Decals - Miscellaneous.....	93012C03.1	Adhésifs - Divers	Adhesivos - Varios
Decals - Miscellaneous.....	93013C03.1	Adhésifs - Divers	Adhesivos - Varios
Decals - Miscellaneous.....	93014C03.1	Adhésifs - Divers	Adhesivos - Varios
Decals - Miscellaneous.....	93015C03.1	Adhésifs - Divers	Adhesivos - Varios
Decals - Miscellaneous.....	93016C03.1	Adhésifs - Divers	Adhesivos - Varios
Decals - Miscellaneous.....	93017C03.1	Adhésifs - Divers	Adhesivos - Varios
Decals - Miscellaneous.....	93018C03.1	Adhésifs - Divers	Adhesivos - Varios
Decals - Miscellaneous.....	93019C01.1	Adhésifs - Divers	Adhesivos - Varios
Decals - Miscellaneous.....	93020C03.1	Adhésifs - Divers	Adhesivos - Varios
Decals - Miscellaneous.....	93021C03.1	Adhésifs - Divers	Adhesivos - Varios
Decals - Miscellaneous.....	93022C03.1	Adhésifs - Divers	Adhesivos - Varios
Decals - Miscellaneous.....	93023C03.1	Adhésifs - Divers	Adhesivos - Varios
Decals - Warnings	93001C01.1	Adhésifs - Avertissements	Adhesivos - Avisos
Decals - Warnings	93002C01.1	Adhésifs - Avertissements	Adhesivos - Avisos
Decals - Warnings	93003C01.1	Adhésifs - Avertissements	Adhesivos - Avisos
Decals - Warnings	93004C01.1	Adhésifs - Avertissements	Adhesivos - Avisos
Decals - Warnings	93005C01.1	Adhésifs - Avertissements	Adhesivos - Avisos
Decals - Warnings	93006C01.1	Adhésifs - Avertissements	Adhesivos - Avisos
Decals - Warnings	93007C01.1	Adhésifs - Avertissements	Adhesivos - Avisos
Decals - Warnings	93008C01.1	Adhésifs - Avertissements	Adhesivos - Avisos
Decals - Warnings	93009C01.1	Adhésifs - Avertissements	Adhesivos - Avisos
Decals - Warnings	93010C01.1	Adhésifs - Avertissements	Adhesivos - Avisos



Q - Legal Requirements • Obligations légales • Requisitos legales

Decals - Warnings93011C01.1	Adhésifs - Avertissements	Adhesivos - Avisos
Decals - Warnings93012C01.1	Adhésifs - Avertissements	Adhesivos - Avisos
Decals - Warnings93013C01.1	Adhésifs - Avertissements	Adhesivos - Avisos
Decals - Warnings93014C01.1	Adhésifs - Avertissements	Adhesivos - Avisos
Decals - Warnings93015C01.1	Adhésifs - Avertissements	Adhesivos - Avisos
Decals - Warnings93016C01.1	Adhésifs - Avertissements	Adhesivos - Avisos
Decals - Warnings93017C01.1	Adhésifs - Avertissements	Adhesivos - Avisos
Decals - Warnings93018C01.1	Adhésifs - Avertissements	Adhesivos - Avisos
Decals - Warnings93020C01.1	Adhésifs - Avertissements	Adhesivos - Avisos
Decals - Warnings93021C01.1	Adhésifs - Avertissements	Adhesivos - Avisos
Decals - Warnings93022C01.1	Adhésifs - Avertissements	Adhesivos - Avisos
Decals - Warnings93023C01.1	Adhésifs - Avertissements	Adhesivos - Avisos
Digger Stabilisers - Safety Kit.....95015C01.1	Stabilisateurs - Coffret de Sécurité	Estabilizadores - Juego de seguridad
Headlamp Extension95014C01.1	Extension de Phare	Extensión para el faro delantero
Licence Plate95010C01.1	Plaque Minéralogique	Placa de matrícula
Licence Plate95011C01.1	Plaque Minéralogique	Placa de matrícula
Literature96011C01.1	Documentation	Documentación
Literature96012C01.1	Documentation	Documentación
Literature96013C01.1	Documentation	Documentación
Literature96014C01.1	Documentation	Documentación
Literature96015C01.1	Documentation	Documentación
Literature96016C01.1	Documentation	Documentación
Literature96017C01.1	Documentation	Documentación
Literature96018C01.1	Documentation	Documentación
Literature96019C01.1	Documentation	Documentación
Literature96020C01.1	Documentation	Documentación
Literature96021C01.1	Documentation	Documentación
Literature96022C01.1	Documentation	Documentación
Literature96023C01.1	Documentation	Documentación
Literature96026C01.1	Documentation	Documentación
Literature96028C01.1	Documentation	Documentación
Literature96029C01.1	Documentation	Documentación
Literature96041C01.1	Documentation	Documentación
Literature96042C01.1	Documentation	Documentación
Literature96043C01.1	Documentation	Documentación
Literature96044C01.1	Documentation	Documentación
Literature96045C01.1	Documentation	Documentación
Literature96046C01.1	Documentation	Documentación



Q - Legal Requirements • Obligations légales • Requisitos legales

Literature	96047C01.1	Documentation	Documentación
Position Indicator - Loader Arm	95013C01.1	Témoïn de Position - Bras Chargeur	Indicador de posición - Brazo cargador
Rotating Beacon Kit.....	98015AC01.1	Coffret de Feu Intermittent	Juego de luz giratoria
Rotating Beacon Kit.....	98015C01.1	Coffret de Feu Intermittent	Juego de luz giratoria
Transport Chain.....	95016C01.1	Chaîne de Transport	Cadena de transporte
Transport Lock - Loader	95017C01.1	Verrouillage de Transport - Chargeur	Bloqueo de transporte - Cargadora
Transport Side Plate - Loader	95018C01.1	Plaque Latérale de Transport - Chargeur	Placa de transporte lateral - Cargadora
Wheel Wedge.....	95012C01.1	Clavette de Calage de Roue	Calzo de bloqueo de la rueda



Decals
Adhésifs
Adhesivos

Craning Valve Kit
Coffret de Distributeur de Commande
Manutention
Juego de distribuidor de mando de
mantenimiento

C-95019-01.1-A

1 6110248M1

(F) Craning 820

1 Decal

Adhésif

Adhesivo

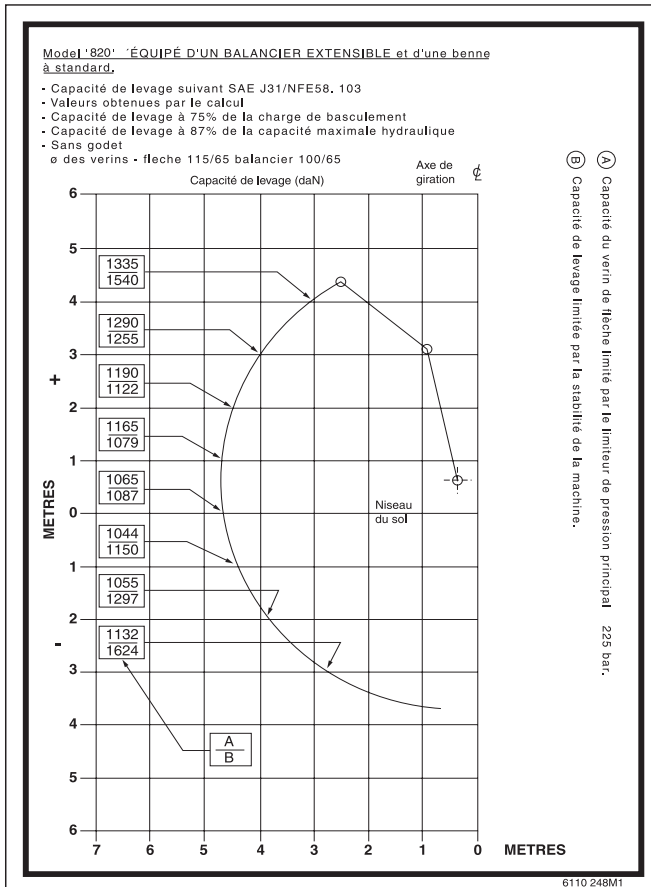

820
TX760B

805 807

95019C01.1

6199042M3

1

Jan-06

Decals
Adhésifs
Adhesivos

Craning Valve Kit
Coffret de Distributeur de Commande
Manutention
Juego de distribuidor de mando de
mantenimiento

C-95020-01.1-B

1	6106504M3	(F) Craning 860/880	1	Decal	Adhésif	Adhesivo
---	-----------	---------------------	---	-------	---------	----------

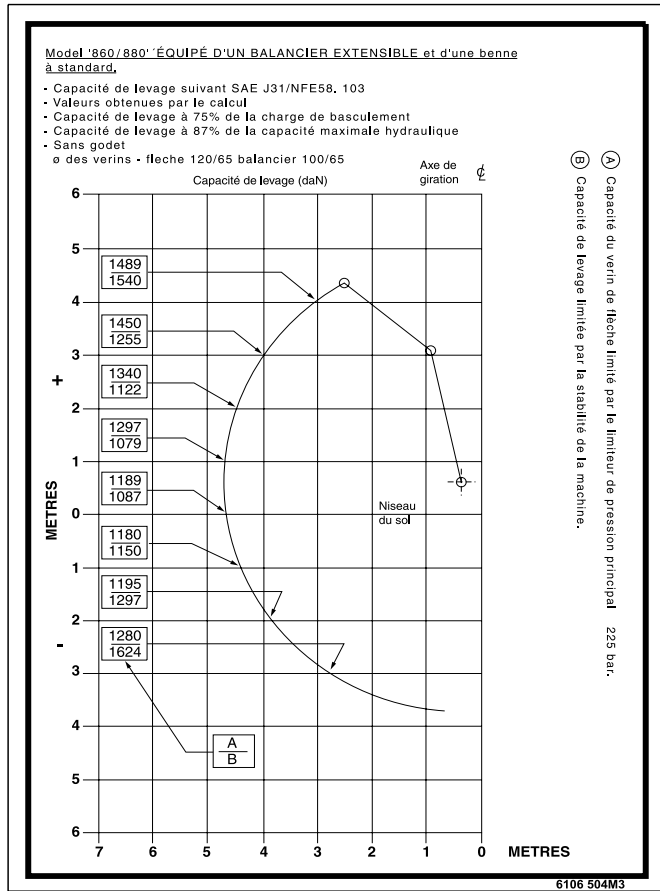

860 880
TX860B

817 845

95020C01.1

6199042M3

1

Jan-06

Decals
Adhésifs
Adhesivos

Craning Valve Kit
Coffret de Distributeur de Commande
Manutention
Juego de distribuidor de mando de
mantenimiento

C-95021-01.1-B

1	6110249M2	(F) Craning 970/980	1	Decal	Adhésif	Adhesivo
---	-----------	---------------------	---	-------	---------	----------

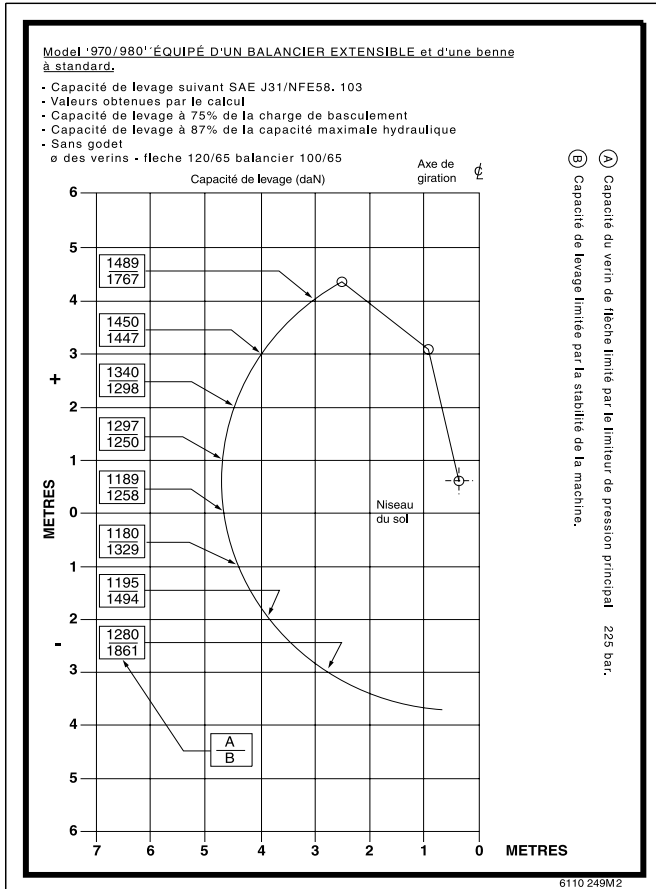

860 880 970 980
TX860B

825 845 855 921 931

95021C01.1

6199042M3

1

Jan-06

C-93001-02.1-C

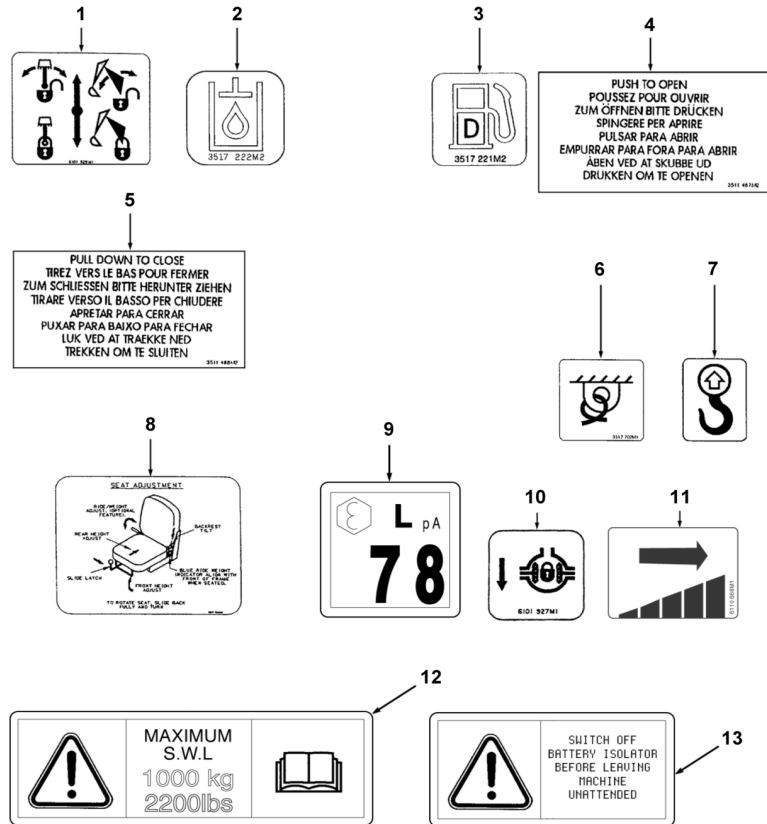

1	6101928M1	Transport Lock	1	Decal	Adhésif	Adhesivo
2	3517222M3	Hydraulic Oil	1	Decal	Adhésif	Adhesivo
3	3517221M3	Diesel Fuel	1	Decal	Adhésif	Adhesivo
4	3511487M2	Push Window	1	Decal	Adhésif	Adhesivo
5	3511488M2	Pull Window	1	Decal	Adhésif	Adhesivo
6	3517702M1	Tie Down	4	Decal	Adhésif	Adhesivo
7	3517703M1	Lifting	4	Decal	Adhésif	Adhesivo
8	6102191M1	Seat Adjust	1	Decal	Adhésif	Adhesivo
9	6009536M1	Noise 78 LPA	1	Decal	Adhésif	Adhesivo
10	6101927M1	Diff Lock	1	Decal	Adhésif	Adhesivo
11	6110668M1	Hand Throttle	1	Decal	Adhésif	Adhesivo
12	6102194M1	Safe Working	2	Decal	Adhésif	Adhesivo
13	6108495M1	Battery Isolator	1	Decal	Adhésif	Adhesivo



820 860 880 970 980
TX760B TX860B
TX870B TX970B

801 803 805 807 813 815 817 821 823 825 841 843 845 851 853 855 921 922 923
931 932

C-93002-02.1-C

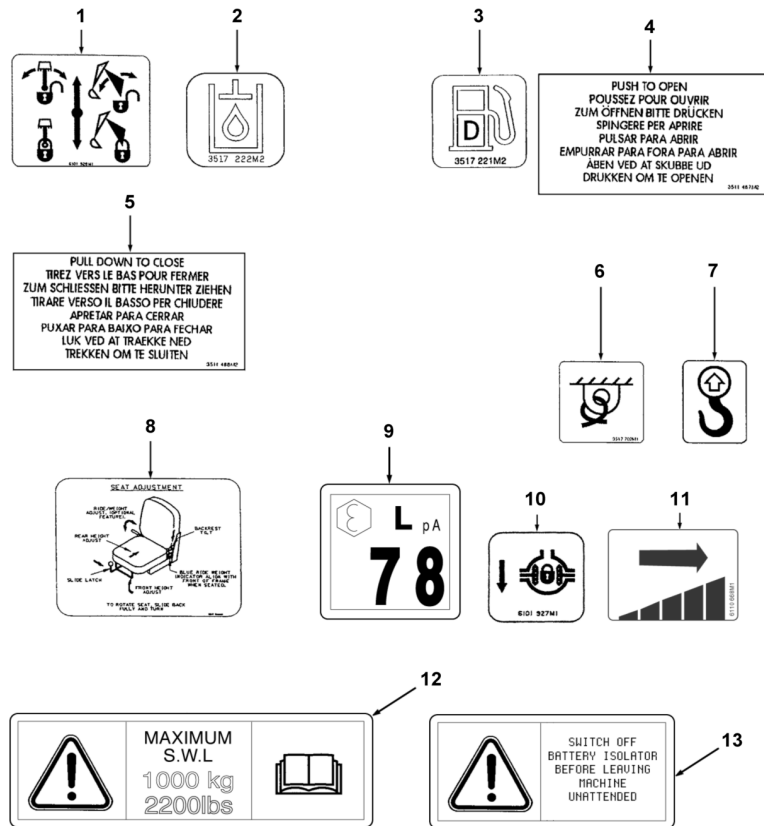

1	6101928M1	Transport Lock	1	Decal	Adhésif	Adhesivo
2	3517222M3	Hydraulic Oil	1	Decal	Adhésif	Adhesivo
3	3517221M3	Diesel Fuel	1	Decal	Adhésif	Adhesivo
4	3511487M2	Push Window	1	Decal	Adhésif	Adhesivo
5	3511488M2	Pull Window	1	Decal	Adhésif	Adhesivo
6	3517702M1	Tie Down	4	Decal	Adhésif	Adhesivo
7	3517703M1	Lifting	4	Decal	Adhésif	Adhesivo
8	6102191M1	Seat Adjust	1	Decal	Adhésif	Adhesivo
9	6009536M1	Noise 78 LPA	1	Decal	Adhésif	Adhesivo
10	6101927M1	Diff Lock	1	Decal	Adhésif	Adhesivo
11	6110668M1	Hand Throttle	1	Decal	Adhésif	Adhesivo
12	6102194M1	Safe Working	2	Decal	Adhésif	Adhesivo
13	6108496M1	Battery Isolator	1	Decal	Adhésif	Adhesivo



820 860 880 970 980
TX760B TX860B

805 807 817 825 845 855 921 931

**Decals
Adhésifs
Adhesivos**

**Instructions
Instructions
Instrucciones**

C-93003-02.1-C

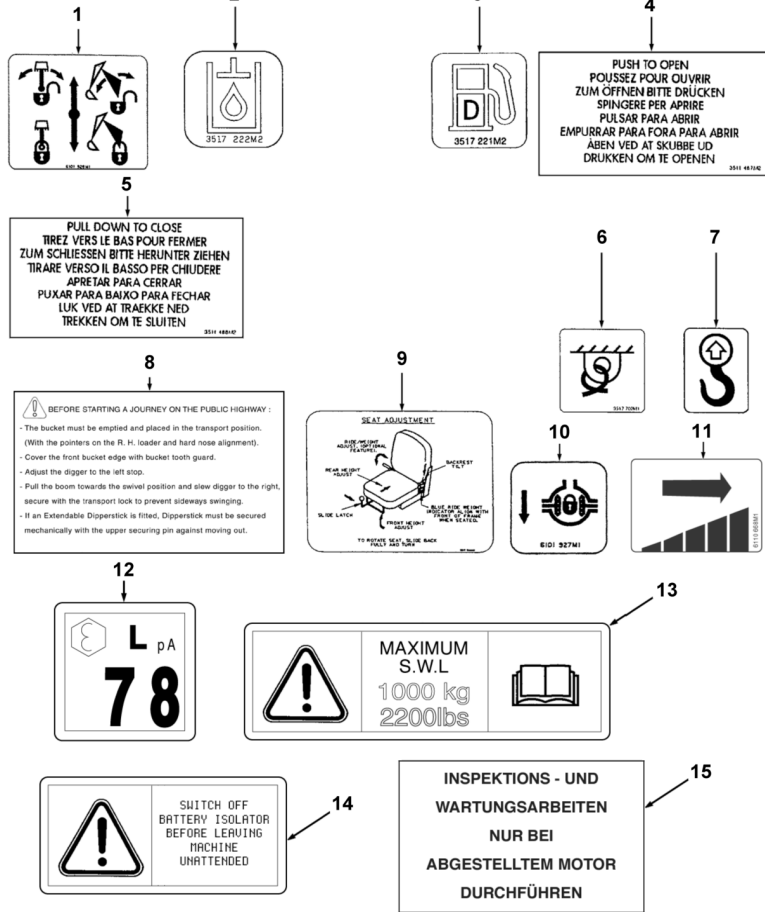

1	6101928M1	Transport Lock	1	Decal	Adhésif	Adhesivo
2	3517222M3	Hydraulic Oil	1	Decal	Adhésif	Adhesivo
3	3517221M3	Diesel Fuel	1	Decal	Adhésif	Adhesivo
4	3511487M2	Push Window	1	Decal	Adhésif	Adhesivo
5	3511488M2	Pull Window	1	Decal	Adhésif	Adhesivo
6	3517702M1	Tie Down	4	Decal	Adhésif	Adhesivo
7	3517703M1	Lifting	4	Decal	Adhésif	Adhesivo
8	3516760M1	Operating instructions	1	Decal	Adhésif	Adhesivo
9	6102191M1	Seat Adjust	1	Decal	Adhésif	Adhesivo
10	6101927M1	Diff Lock	1	Decal	Adhésif	Adhesivo
11	6110668M1	Hand Throttle	1	Decal	Adhésif	Adhesivo
12	6009536M1	Noise 78 LPA	1	Decal	Adhésif	Adhesivo
13	6102194M1	Safe Working	2	Decal	Adhésif	Adhesivo
14	6108500M1	Battery Isolate	1	Decal	Adhésif	Adhesivo
15	1731440M1	Inspection	1	Decal	Adhésif	Adhesivo



820 860 880
TX760B TX860B

805 807 817 825 845 855

**Decals
Adhésifs
Adhesivos**

**Instructions
Instructions
Instrucciones**

C-93004-02.1-D

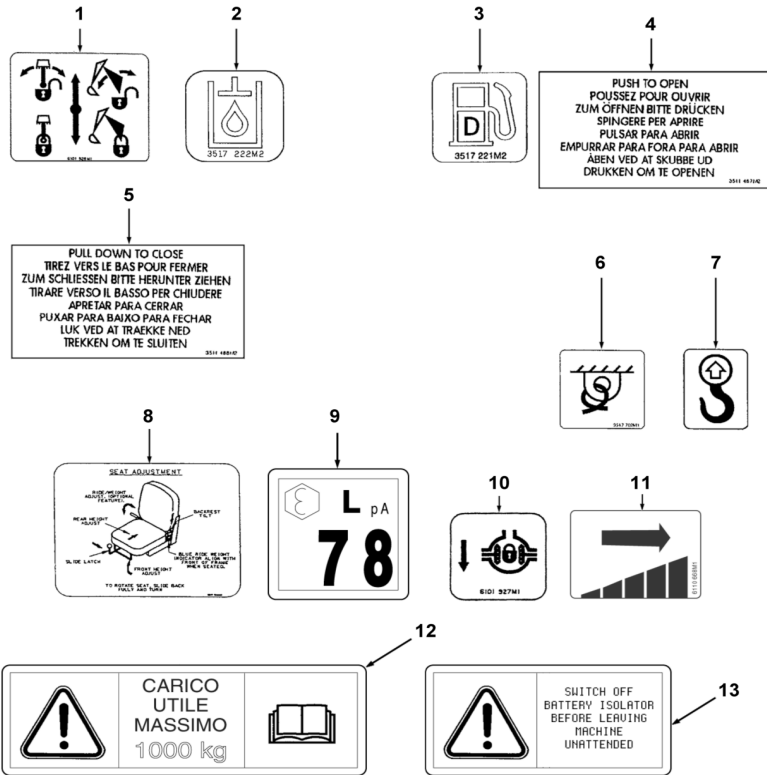

1	6101928M1	Transport Lock	1	Decal	Adhésif	Adhesivo
2	3517222M3	Hydraulic Oil	1	Decal	Adhésif	Adhesivo
3	3517221M3	Diesel Fuel	1	Decal	Adhésif	Adhesivo
4	3511487M2	Push Window	1	Decal	Adhésif	Adhesivo
5	3511488M2	Pull Window	1	Decal	Adhésif	Adhesivo
6	3517702M1	Tie Down	4	Decal	Adhésif	Adhesivo
7	3517703M1	Lifting	4	Decal	Adhésif	Adhesivo
8	6102191M1	Seat Adjust	1	Decal	Adhésif	Adhesivo
9	6009536M1	Noise 78 LPA	1	Decal	Adhésif	Adhesivo
10	6101927M1	Diff Lock	2	Decal	Adhésif	Adhesivo
11	6110668M1	Hand Throttle	1	Decal	Adhésif	Adhesivo
12	6110494M1	Safe Working	2	Decal	Adhésif	Adhesivo
13	6108497M1	Battery Isolate	1	Decal	Adhésif	Adhesivo



820 860 880 970 980
TX760B TX860B

805 807 817 825 845 855 921 931

**Decals
Adhésifs
Adhesivos**

**Instructions
Instructions
Instrucciones**

C-93005-02.1-C

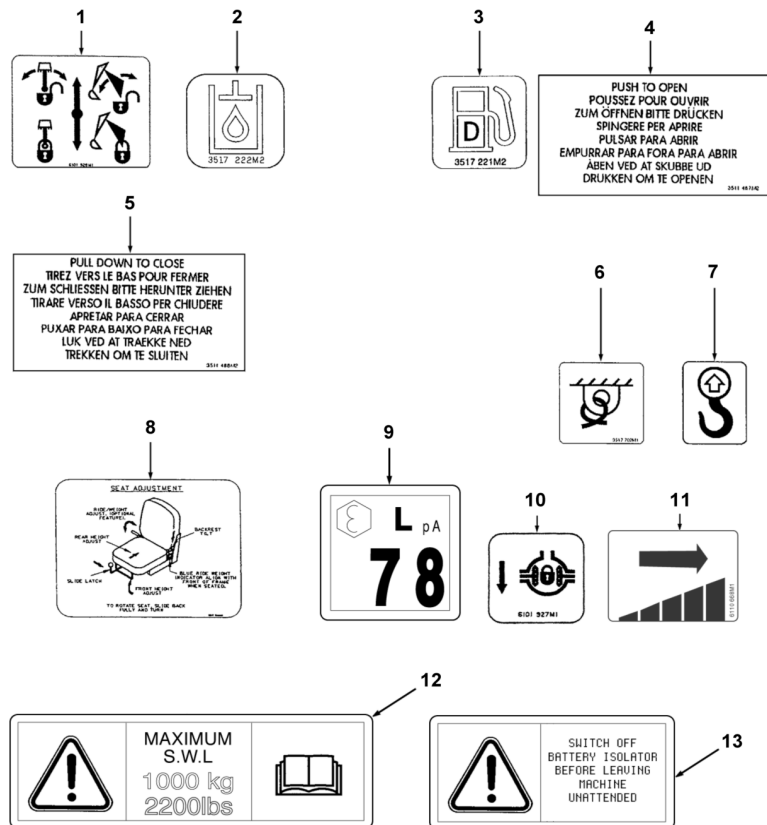

1	6101928M1	Transport Lock	1	Decal	Adhésif	Adhesivo
2	3517222M3	Hydraulic Oil	1	Decal	Adhésif	Adhesivo
3	3517221M3	Diesel Fuel	1	Decal	Adhésif	Adhesivo
4	3511487M2	Push Window	1	Decal	Adhésif	Adhesivo
5	3511488M2	Pull Window	1	Decal	Adhésif	Adhesivo
6	3517702M1	Tie Down	4	Decal	Adhésif	Adhesivo
7	3517703M1	Lifting	4	Decal	Adhésif	Adhesivo
8	6102191M1	Seat Adjust	1	Decal	Adhésif	Adhesivo
9	6009536M1	Noise 78 LPA	1	Decal	Adhésif	Adhesivo
10	6101927M1	Diff Lock	1	Decal	Adhésif	Adhesivo
11	6110668M1	Hand Throttle	1	Decal	Adhésif	Adhesivo
12	6102194M1	Safe Working	2	Decal	Adhésif	Adhesivo
13	6108498M1	Battery Isolator	1	Decal	Adhésif	Adhesivo



820 860 880 970 980
TX760B TX860B
TX870B TX970B

801 803 805 807 813 815 817 821 823 825 841 842 843 844 845 851 853 855 921
922 923 931 932

**Decals
Adhésifs
Adhesivos**

**Instructions
Instructions
Instrucciones**

C-93006-02.1-B

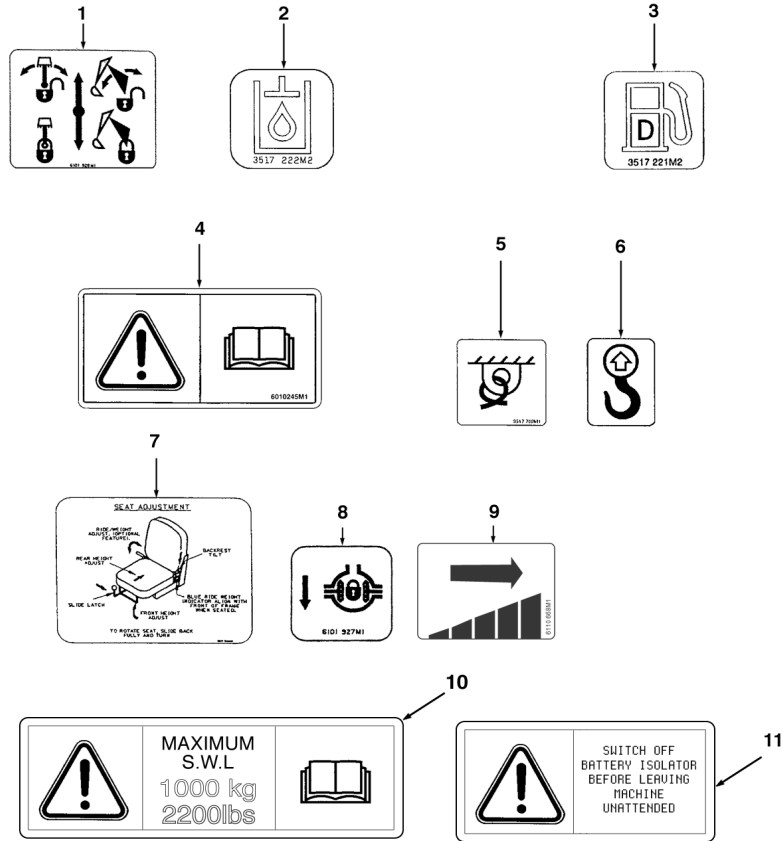

1	6101928M1	Transport Lock	1	Decal	Adhésif	Adhesivo
2	3517222M3	Hydraulic Oil	1	Decal	Adhésif	Adhesivo
3	3517221M3	Diesel Fuel	1	Decal	Adhésif	Adhesivo
4	6108692M1	Read O.I.B.	1	Decal	Adhésif	Adhesivo
5	3517702M1	Tie Down	4	Decal	Adhésif	Adhesivo
6	3517703M1	Lifting	4	Decal	Adhésif	Adhesivo
7	6102191M1	Seat Adjust	1	Decal	Adhésif	Adhesivo
8	6101927M1	Diff Lock	1	Decal	Adhésif	Adhesivo
9	6110668M1	Hand Throttle	1	Decal	Adhésif	Adhesivo
10	6102194M1	Safe Working	2	Decal	Adhésif	Adhesivo
11	6108495M1	Battery Isolate	1	Decal	Adhésif	Adhesivo



820 860 880
TX760B TX860B
TX870B

802 804 806 808 814 816 822 824 842 844 852 854

**Decals
Adhésifs
Adhesivos**

**Instructions
Instructions
Instrucciones**

C-93007-02.1-C

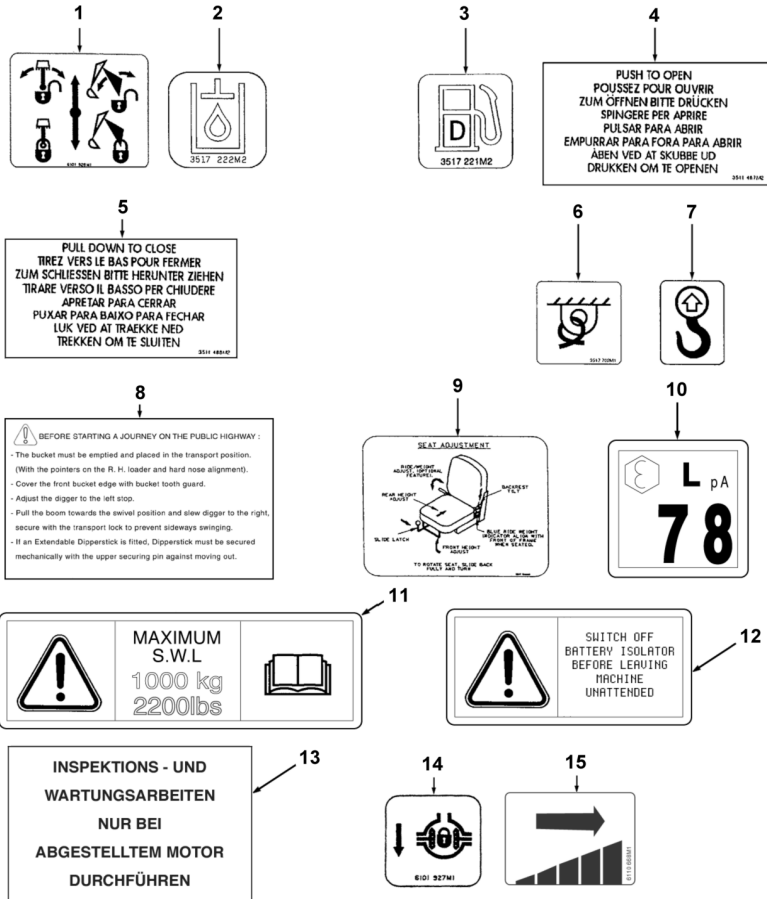

1	6101928M1	Transport Lock	1	Decal	Adhésif	Adhesivo
2	3517222M3	Hydraulic Oil	1	Decal	Adhésif	Adhesivo
3	3517221M3	Diesel Fuel	1	Decal	Adhésif	Adhesivo
4	3511487M2	Push Window	1	Decal	Adhésif	Adhesivo
5	3511488M2	Pull Window	1	Decal	Adhésif	Adhesivo
6	3517702M1	Tie Down	4	Decal	Adhésif	Adhesivo
7	3517703M1	Lifting	4	Decal	Adhésif	Adhesivo
8	3516760M1	Operating instructions	1	Decal	Adhésif	Adhesivo
9	6102191M1	Seat Adjust	1	Decal	Adhésif	Adhesivo
10	6009536M1	Noise 78 LPA	1	Decal	Adhésif	Adhesivo
11	6102194M1	Safe Working	2	Decal	Adhésif	Adhesivo
12	6108500M1	Battery Isolate	1	Decal	Adhésif	Adhesivo
13	1731440M1	Inspection	1	Decal	Adhésif	Adhesivo
14	6101927M1	Diff Lock	1	Decal	Adhésif	Adhesivo
15	6110668M1	Hand Throttle	1	Decal	Adhésif	Adhesivo



820 860 880 970 980
TX760B TX860B
TX870B

805 807 817 825 843 845 855 921 931

Decals
Adhésifs
Adhesivos

Instructions
Instructions
Instrucciones

C-93008-02.1-C

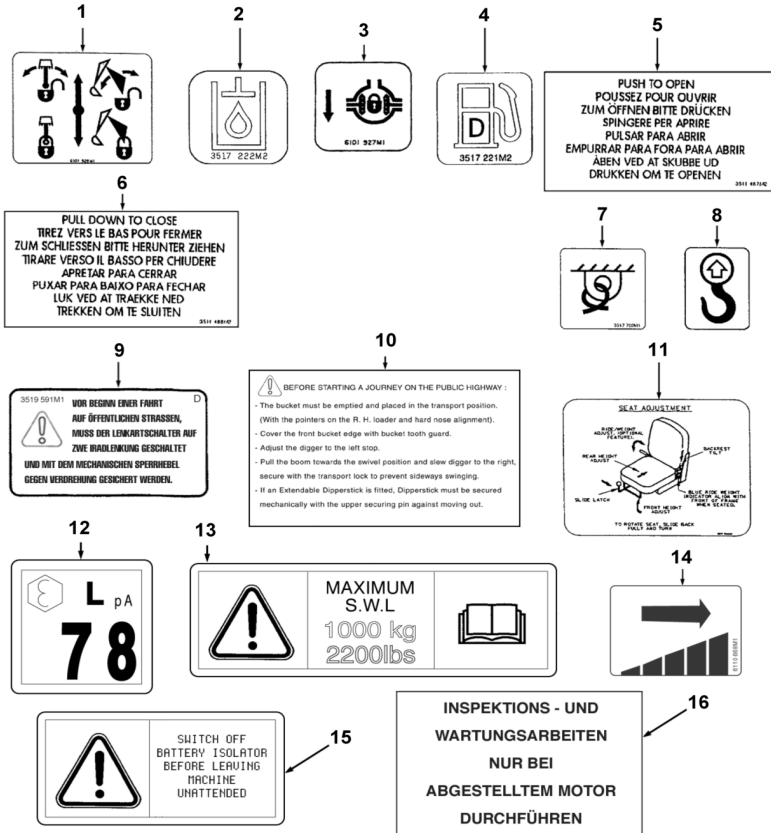

1	6101928M1	Transport Lock	1	Decal	Adhésif	Adhesivo
2	3517222M3	Hydraulic Oil	1	Decal	Adhésif	Adhesivo
3	6101927M1	Diff Lock	1	Decal	Adhésif	Adhesivo
4	3517221M3	Diesel Fuel	1	Decal	Adhésif	Adhesivo
5	3511487M2	Push Window	1	Decal	Adhésif	Adhesivo
6	3511488M2	Pull Window	1	Decal	Adhésif	Adhesivo
7	3517702M1	Tie Down	4	Decal	Adhésif	Adhesivo
8	3517703M1	Lifting	4	Decal	Adhésif	Adhesivo
9	3519591M1	2WS Rooding	1	Decal	Adhésif	Adhesivo
10	3516760M1	Operating instructions	1	Decal	Adhésif	Adhesivo
11	6102191M1	Seat Adjust	1	Decal	Adhésif	Adhesivo
12	6009536M1	Noise 78 LPA	1	Decal	Adhésif	Adhesivo
13	6102194M1	Safe Working	2	Decal	Adhésif	Adhesivo
14	6110668M1	Hand Throttle	1	Decal	Adhésif	Adhesivo
15	6108500M1	Battery Isolate	1	Decal	Adhésif	Adhesivo
16	1731440M1	Inspection	1	Decal	Adhésif	Adhesivo



970 980

921 931

C-93009-02.1-C

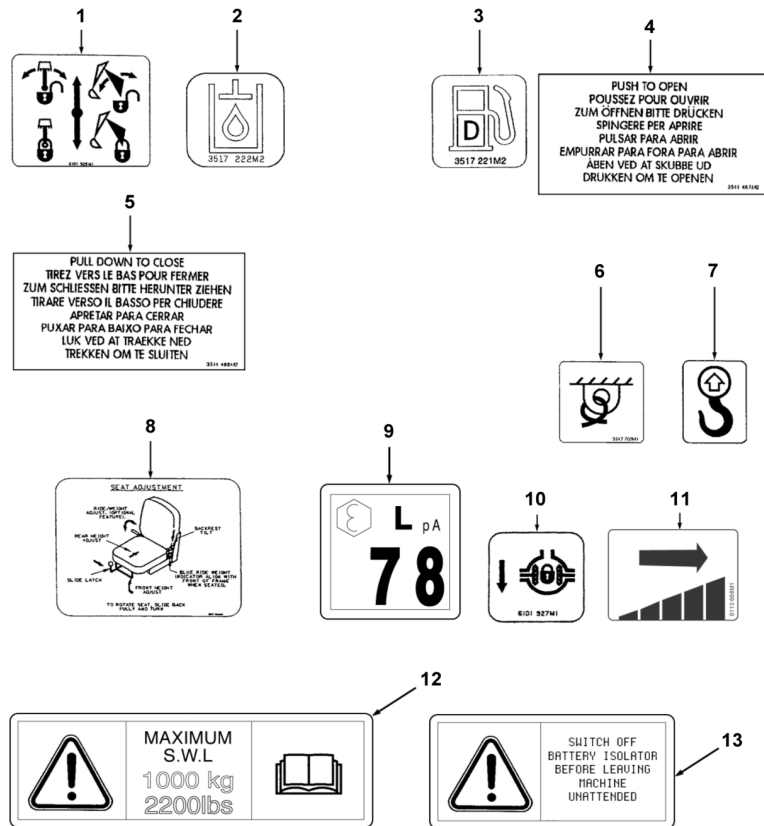

1	6101928M1	Transport Lock	1	Decal	Adhésif	Adhesivo
2	3517222M3	Hydraulic Oil	1	Decal	Adhésif	Adhesivo
3	3517221M3	Diesel Fuel	1	Decal	Adhésif	Adhesivo
4	3511487M2	Push Window	1	Decal	Adhésif	Adhesivo
5	3511488M2	Pull Window	1	Decal	Adhésif	Adhesivo
6	3517702M1	Tie Down	4	Decal	Adhésif	Adhesivo
7	3517703M1	Lifting	4	Decal	Adhésif	Adhesivo
8	6102191M1	Seat Adjust	1	Decal	Adhésif	Adhesivo
9	6009536M1	Noise 78 LPA	1	Decal	Adhésif	Adhesivo
10	6101927M1	Diff Lock	1	Decal	Adhésif	Adhesivo
11	6110668M1	Hand Throttle	1	Decal	Adhésif	Adhesivo
12	6102194M1	Safe Working	2	Decal	Adhésif	Adhesivo
13	6108501M1	Battery Isolator	1	Decal	Adhésif	Adhesivo



820 860 880 970 980
TX760B TX860B
TX870B

805 807 817 825 843 845 855 921 931

C-93010-02.1-C

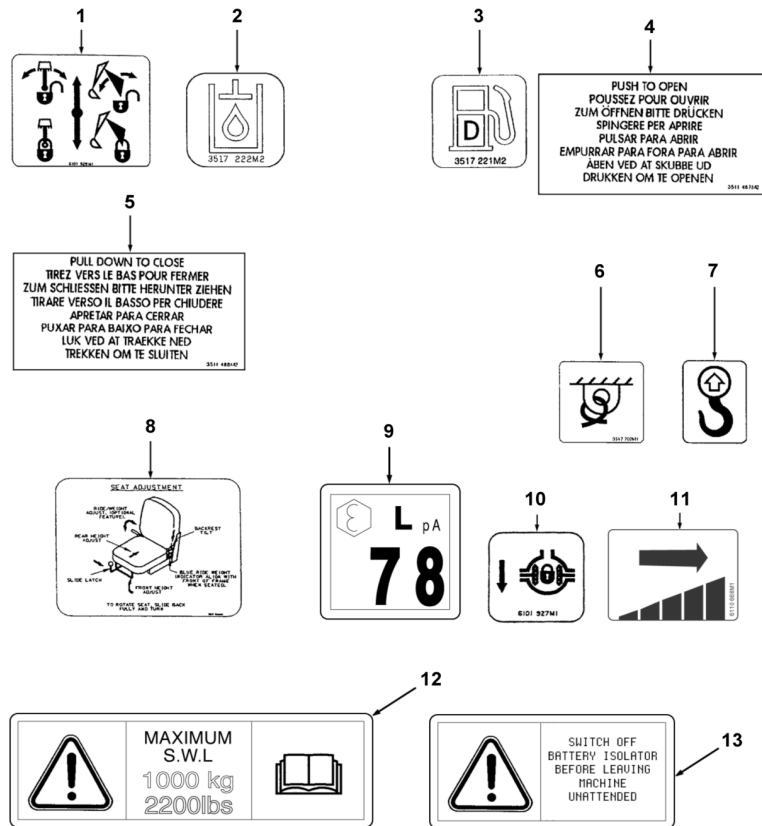

1	6101928M1	Transport Lock	1	Decal	Adhésif	Adhesivo
2	3517222M3	Hydraulic Oil	1	Decal	Adhésif	Adhesivo
3	3517221M3	Diesel Fuel	1	Decal	Adhésif	Adhesivo
4	3511487M2	Push Window	1	Decal	Adhésif	Adhesivo
5	3511488M2	Pull Window	1	Decal	Adhésif	Adhesivo
6	3517702M1	Tie Down	4	Decal	Adhésif	Adhesivo
7	3517703M1	Lifting	4	Decal	Adhésif	Adhesivo
8	6102191M1	Seat Adjust	1	Decal	Adhésif	Adhesivo
9	6009536M1	Noise 78 LPA	1	Decal	Adhésif	Adhesivo
10	6101927M1	Diff Lock	1	Decal	Adhésif	Adhesivo
11	6110668M1	Hand Throttle	1	Decal	Adhésif	Adhesivo
12	6102194M1	Safe Working	2	Decal	Adhésif	Adhesivo
13	6108502M1	Battery Isolator	1	Decal	Adhésif	Adhesivo



820 860 880 970 980
TX760B TX860B
TX870B

805 807 817 825 843 845 855 921 931

**Decals
Adhésifs
Adhesivos**

**Instructions
Instructions
Instrucciones**

C-93011-02.1-B

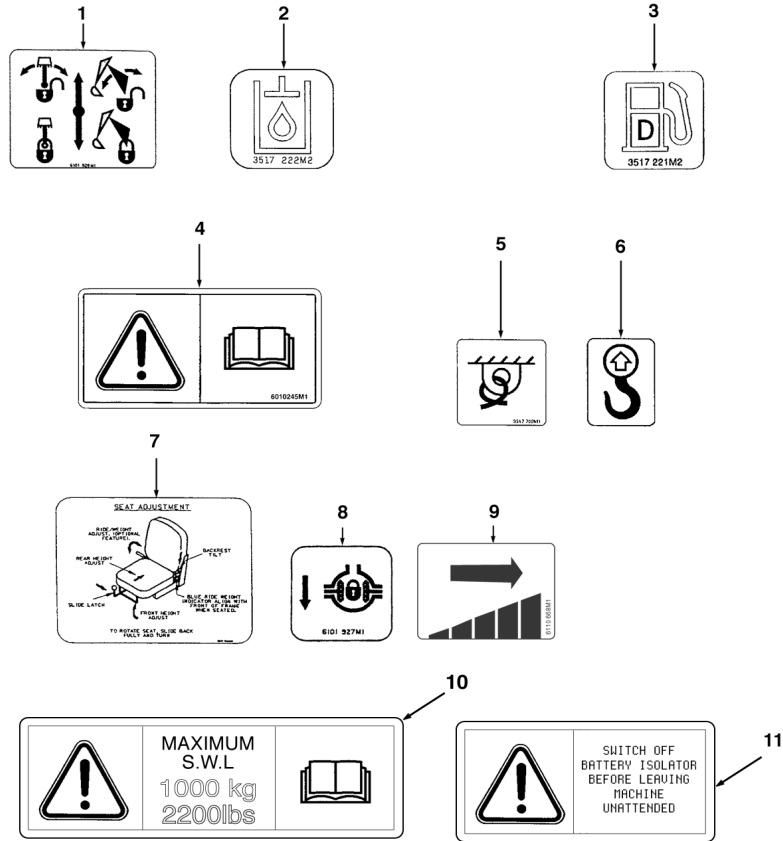

1	6101928M1	Transport Lock	1	Decal	Adhésif	Adhesivo
2	3517222M3	Hydraulic Oil	1	Decal	Adhésif	Adhesivo
3	3517221M3	Diesel Fuel	1	Decal	Adhésif	Adhesivo
4	6108692M1	Read O.I.B.	1	Decal	Adhésif	Adhesivo
5	3517702M1	Tie Down	4	Decal	Adhésif	Adhesivo
6	3517703M1	Lifting	4	Decal	Adhésif	Adhesivo
7	6102191M1	Seat Adjust	1	Decal	Adhésif	Adhesivo
8	6101927M1	Diff Lock	1	Decal	Adhésif	Adhesivo
9	6110668M1	Hand Throttle	1	Decal	Adhésif	Adhesivo
10	6102194M1	Safe Working	2	Decal	Adhésif	Adhesivo
11	6108498M1	Battery Isolate	1	Decal	Adhésif	Adhesivo



820 860 880
TX760B TX860B
TX870B

802 804 806 808 814 816 822 824 842 844 852 854

**Decals
Adhésifs
Adhesivos**

**Instructions
Instructions
Instrucciones**

C-93012-02.1-C

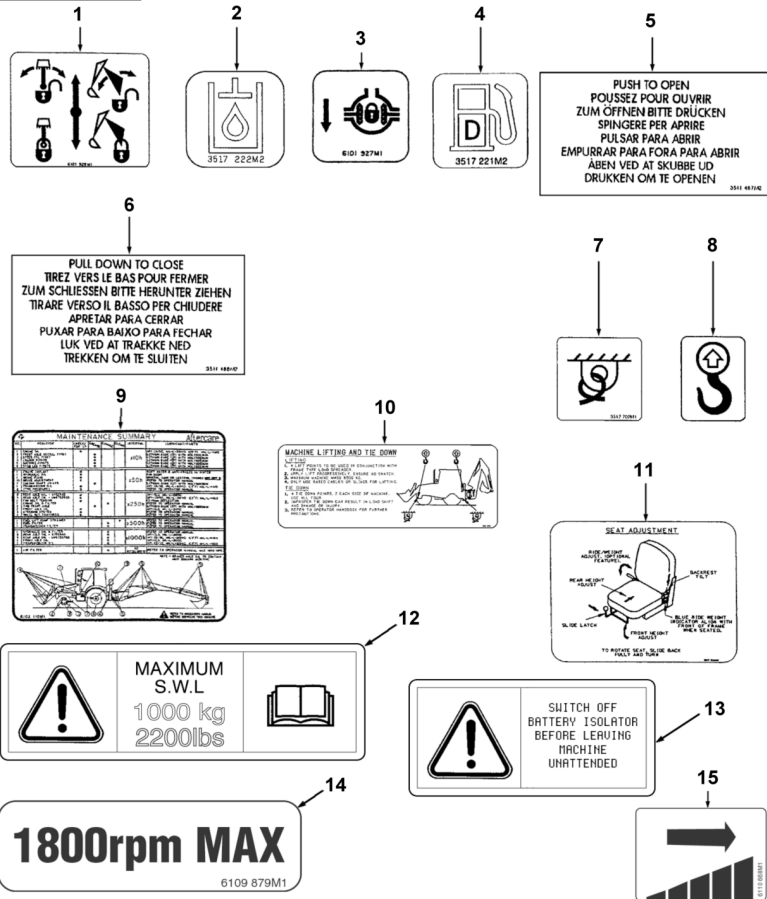

1	6101928M1	Transport Lock	1	Decal	Adhésif	Adhesivo
2	3517222M3	Hydraulic Oil	1	Decal	Adhésif	Adhesivo
3	6101927M1	Diff Lock	1	Decal	Adhésif	Adhesivo
4	3517221M3	Diesel Fuel	1	Decal	Adhésif	Adhesivo
5	3511487M2	Push Window	1	Decal	Adhésif	Adhesivo
6	3511488M2	Pull Window	1	Decal	Adhésif	Adhesivo
7	3517702M1	Tie Down	4	Decal	Adhésif	Adhesivo
8	3517703M1	Lifting	4	Decal	Adhésif	Adhesivo
9	6110328M1	Maintenance	1	Decal	Adhésif	Adhesivo
10	6102109M1	Lifting/Tie Down	1	Decal	Adhésif	Adhesivo
11	6102191M1	Seat Adjust	1	Decal	Adhésif	Adhesivo
12	6102194M1	Safe Working	2	Decal	Adhésif	Adhesivo
13	6108495M1	Battery Isolate	1	Decal	Adhésif	Adhesivo
14	6109879M1	1800rpm MAX	1	Decal	Adhésif	Adhesivo
15	6110668M1	Hand Throttle	1	Decal	Adhésif	Adhesivo



820 860 880 970 980
TX760B TX860B

805 807 817 825 845 855 921 931

**Decals
Adhésifs
Adhesivos**

**Instructions
Instructions
Instrucciones**

C-93013-02.1-C

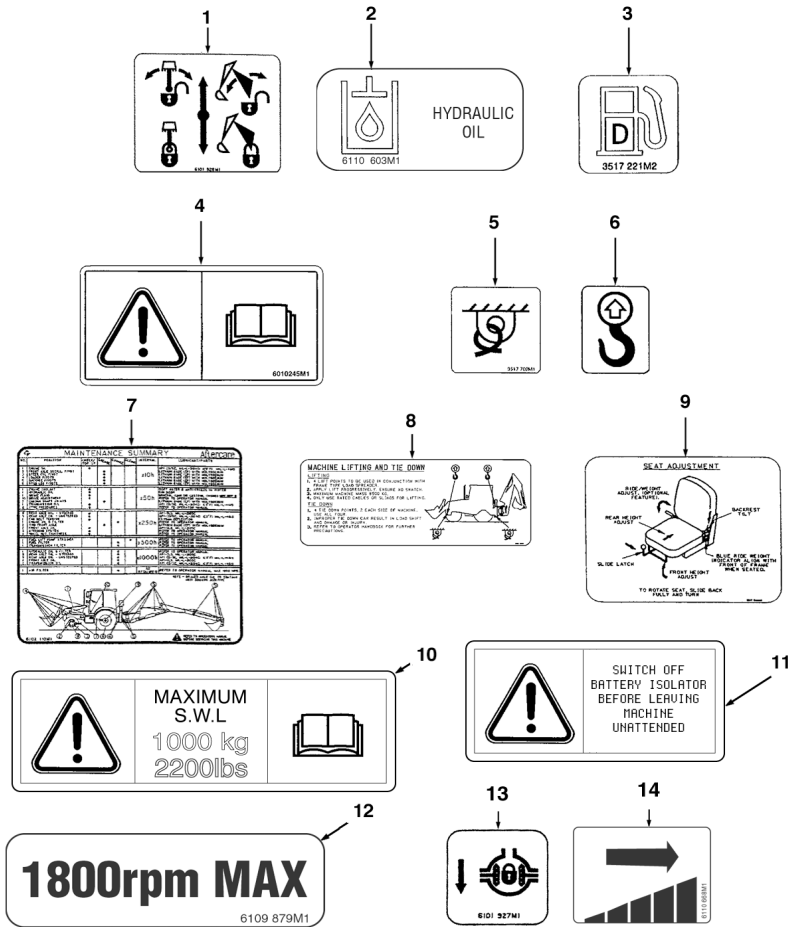

1	6101928M1	Transport Lock	1	Decal	Adhésif	Adhesivo
2	6110603M1	Hydraulic Oil	1	Decal	Adhésif	Adhesivo
3	3517221M3	Diesel Fuel	1	Decal	Adhésif	Adhesivo
4	6108692M1	Read O.I.B.	1	Decal	Adhésif	Adhesivo
5	3517702M1	Tie Down	4	Decal	Adhésif	Adhesivo
6	3517703M1	Lifting	4	Decal	Adhésif	Adhesivo
7	6110328M1	Maintenance	1	Decal	Adhésif	Adhesivo
8	6102109M1	Lifting/Tie Down	1	Decal	Adhésif	Adhesivo
9	6102191M1	Seat Adjust	1	Decal	Adhésif	Adhesivo
10	6102194M1	Safe Working	2	Decal	Adhésif	Adhesivo
11	6108495M1	Battery Isolate	1	Decal	Adhésif	Adhesivo
12	6109879M1	1800rpm MAX	1	Decal	Adhésif	Adhesivo
13	6101927M1	Diff Lock	1	Decal	Adhésif	Adhesivo
14	6110668M1	Hand Throttle	1	Decal	Adhésif	Adhesivo



820 860 880
TX760B TX860B
TX870B

802 804 806 808 810 812 814 816 822 824 832 834 842 844 852 854

**Decals
Adhésifs
Adhesivos**

**Instructions
Instructions
Instrucciones**

C-93014-02.1-D

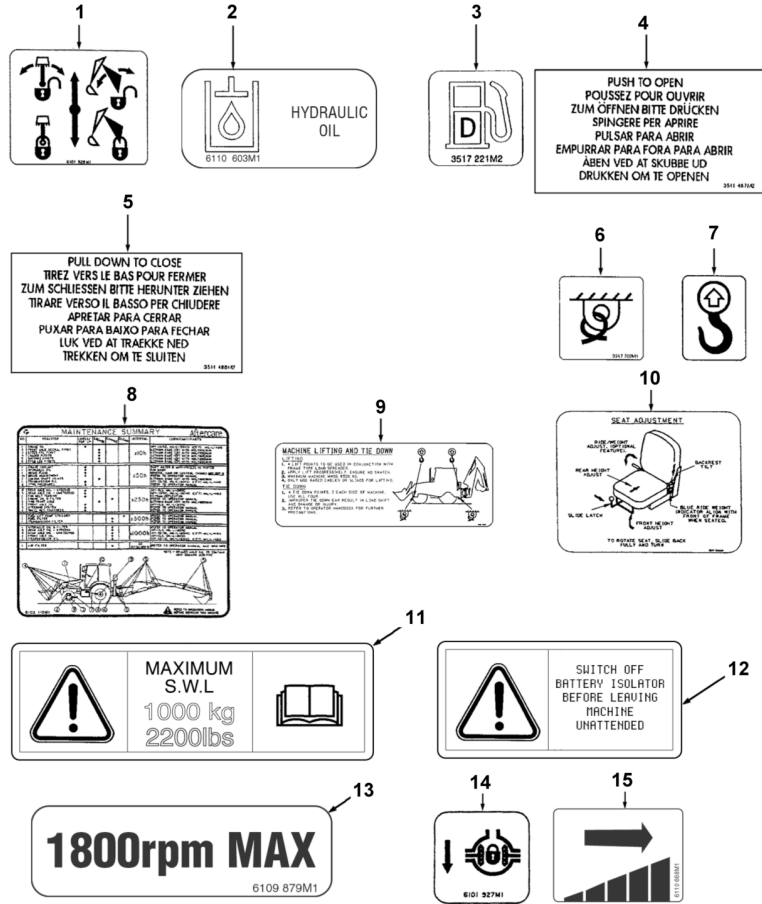

1	6101928M1	Transport Lock	1	Decal	Adhésif	Adhesivo
2	6110603M1	Hydraulic Oil	1	Decal	Adhésif	Adhesivo
3	3517221M3	Diesel Fuel	1	Decal	Adhésif	Adhesivo
4	3511487M2	Push Window	1	Decal	Adhésif	Adhesivo
5	3511488M2	Pull Window	1	Decal	Adhésif	Adhesivo
6	3517702M1	Tie Down	4	Decal	Adhésif	Adhesivo
7	3517703M1	Lifting	4	Decal	Adhésif	Adhesivo
8	6110328M1	Maintenance	1	Decal	Adhésif	Adhesivo
9	6102109M1	Lifting/Tie Down	1	Decal	Adhésif	Adhesivo
10	6102191M1	Seat Adjust	1	Decal	Adhésif	Adhesivo
11	6102194M1	Safe Working	2	Decal	Adhésif	Adhesivo
12	6108495M1	Battery Isolate	1	Decal	Adhésif	Adhesivo
13	6109879M1	1800rpm MAX	1	Decal	Adhésif	Adhesivo
14	6101927M1	Diff Lock	1	Decal	Adhésif	Adhesivo
15	6110668M1	Hand Throttle	1	Decal	Adhésif	Adhesivo



820 860 880
TX760B TX860B
TX870B

801 803 805 807 809 811 813 815 821 823 825 831 833 841 843 851 853 855

C-93015-02.1-C

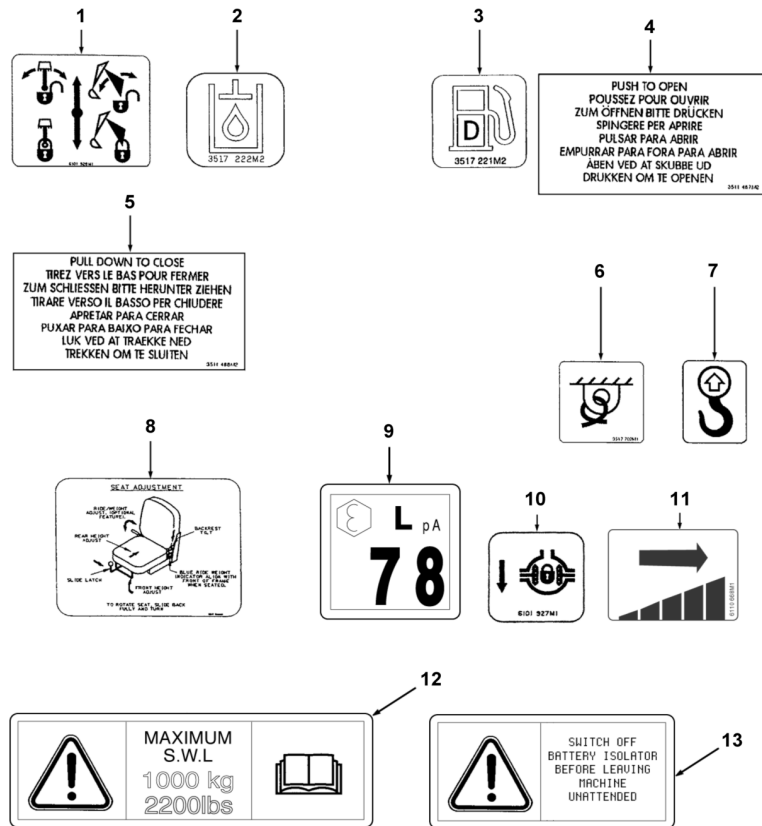

1	6101928M1	Transport Lock	1	Decal	Adhésif	Adhesivo
2	3517222M3	Hydraulic Oil	1	Decal	Adhésif	Adhesivo
3	3517221M3	Diesel Fuel	1	Decal	Adhésif	Adhesivo
4	3511487M2	Push Window	1	Decal	Adhésif	Adhesivo
5	3511488M2	Pull Window	1	Decal	Adhésif	Adhesivo
6	3517702M1	Tie Down	4	Decal	Adhésif	Adhesivo
7	3517703M1	Lifting	4	Decal	Adhésif	Adhesivo
8	6102191M1	Seat Adjust	1	Decal	Adhésif	Adhesivo
9	6009536M1	Noise 78 LPA	1	Decal	Adhésif	Adhesivo
10	6101927M1	Diff Lock	1	Decal	Adhésif	Adhesivo
11	6110668M1	Hand Throttle	1	Decal	Adhésif	Adhesivo
12	6102194M1	Safe Working	2	Decal	Adhésif	Adhesivo
13	6108495M1	Battery Isolator	1	Decal	Adhésif	Adhesivo



820 860 880
TX760B TX860B
TX870B

801 803 805 807 813 815 817 821 823 825 841 843 845 851 853 855

**Decals
Adhésifs
Adhesivos**

**Instructions
Instructions
Instrucciones**

C-93016-02.1-B

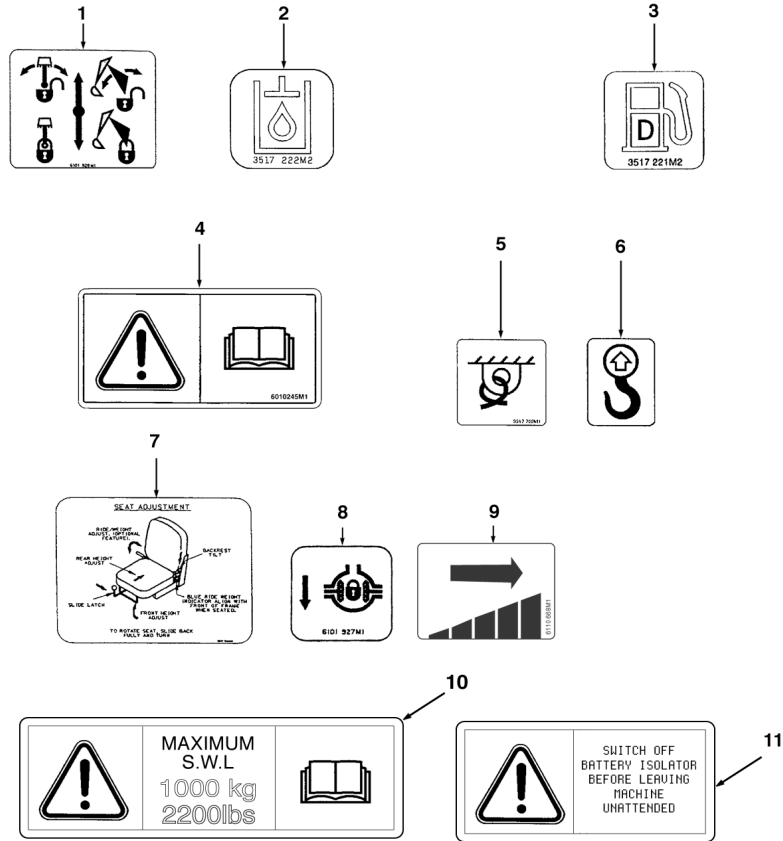

1	6101928M1	Transport Lock	1	Decal	Adhésif	Adhesivo
2	3517222M3	Hydraulic Oil	1	Decal	Adhésif	Adhesivo
3	3517221M3	Diesel Fuel	1	Decal	Adhésif	Adhesivo
4	6108692M1	Read O.I.B.	1	Decal	Adhésif	Adhesivo
5	3517702M1	Tie Down	4	Decal	Adhésif	Adhesivo
6	3517703M1	Lifting	4	Decal	Adhésif	Adhesivo
7	6102191M1	Seat Adjust	1	Decal	Adhésif	Adhesivo
8	6101927M1	Diff Lock	1	Decal	Adhésif	Adhesivo
9	6110668M1	Hand Throttle	1	Decal	Adhésif	Adhesivo
10	6102194M1	Safe Working	2	Decal	Adhésif	Adhesivo
11	6108495M1	Battery Isolate	1	Decal	Adhésif	Adhesivo



820 860 880
TX760B TX860B
TX870B

802 804 806 808 814 816 822 824 842 844 852 854

**Decals
Adhésifs
Adhesivos**

**Instructions
Instructions
Instrucciones**

C-93017-02.1-B

1	6101928M1	Transport Lock	1	Decal	Adhésif	Adhesivo
2	3517222M3	Hydraulic Oil	1	Decal	Adhésif	Adhesivo
3	3517221M3	Diesel Fuel	1	Decal	Adhésif	Adhesivo
4	6108692M1	Read O.I.B.	1	Decal	Adhésif	Adhesivo
5	3517702M1	Tie Down	4	Decal	Adhésif	Adhesivo
6	3517703M1	Lifting	4	Decal	Adhésif	Adhesivo
7	6110328M1	Maintenance	1	Decal	Adhésif	Adhesivo
8	6102109M1	Lifting/Tie Down	1	Decal	Adhésif	Adhesivo
9	6102191M1	Seat Adjust	1	Decal	Adhésif	Adhesivo
10	6101927M1	Diff Lock	1	Decal	Adhésif	Adhesivo
11	6110668M1	Hand Throttle	1	Decal	Adhésif	Adhesivo
12	6102194M1	Safe Working	2	Decal	Adhésif	Adhesivo
13	6108495M1	Battery Isolator	1	Decal	Adhésif	Adhesivo

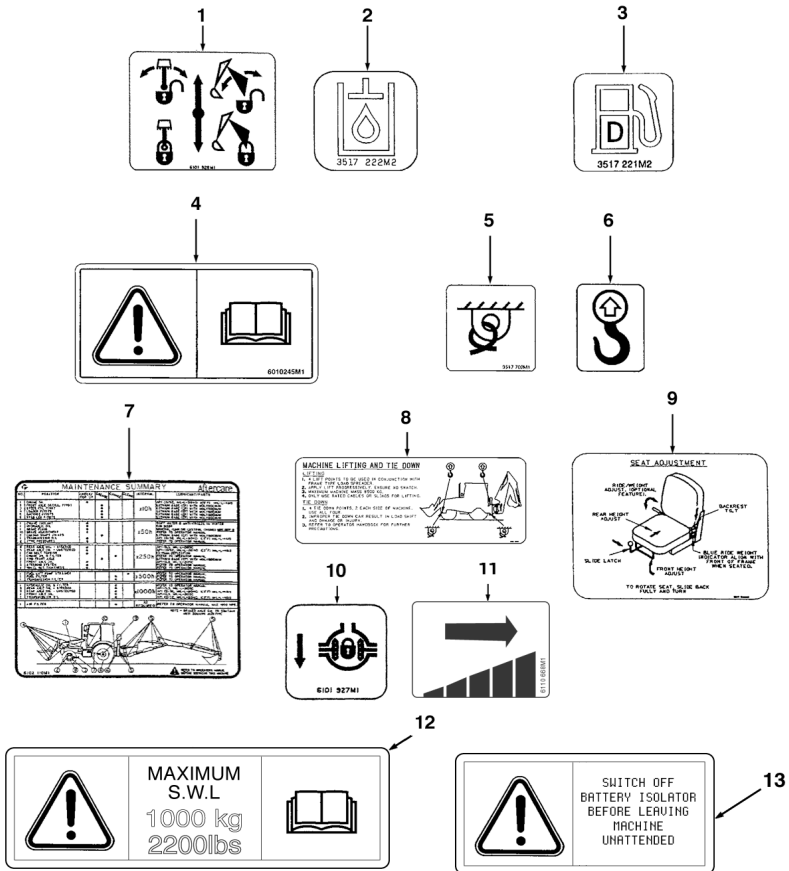

820 860 880
TX760B TX860B
TX870B

802 804 806 808 814 816 822 824 842 844 852 854

C-93018-02.1-C

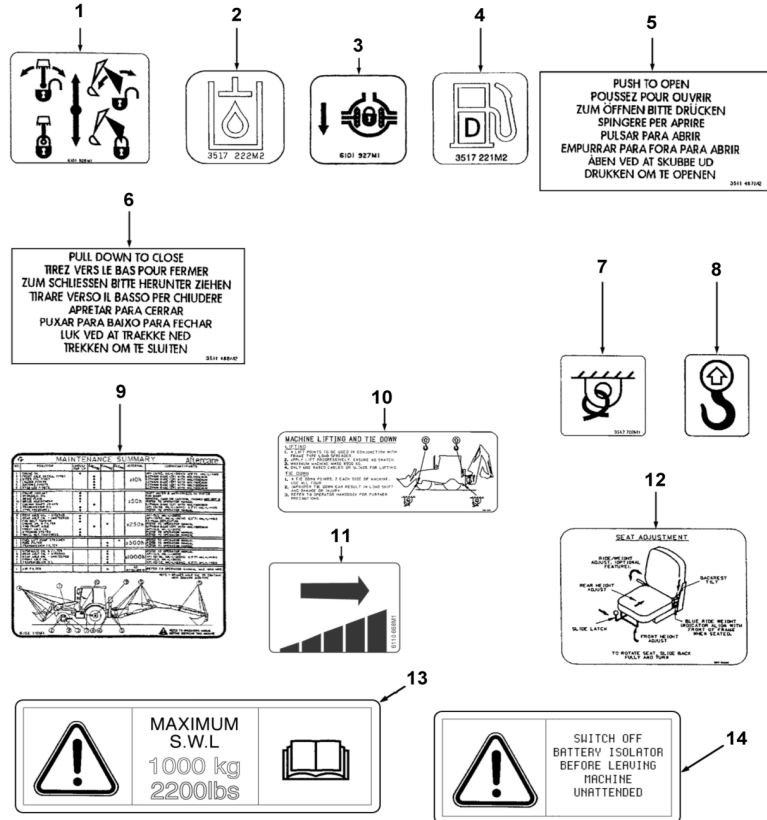

1	6101928M1	Transport Lock	1	Decal	Adhésif	Adhesivo
2	3517222M3	Hydraulic Oil	1	Decal	Adhésif	Adhesivo
3	6101927M1	Diff Lock	1	Decal	Adhésif	Adhesivo
4	3517221M3	Diesel Fuel	1	Decal	Adhésif	Adhesivo
5	3511487M2	Push Window	1	Decal	Adhésif	Adhesivo
6	3511488M2	Pull Window	1	Decal	Adhésif	Adhesivo
7	3517702M1	Tie Down	4	Decal	Adhésif	Adhesivo
8	3517703M1	Lifting	4	Decal	Adhésif	Adhesivo
9	6110328M1	Maintenance	1	Decal	Adhésif	Adhesivo
10	6102109M1	Lifting/Tie Down	1	Decal	Adhésif	Adhesivo
11	6110668M1	Hand Throttle	1	Decal	Adhésif	Adhesivo
12	6102191M1	Seat Adjust	1	Decal	Adhésif	Adhesivo
13	6102194M1	Safe Working	2	Decal	Adhésif	Adhesivo
14	6108495M1	Battery Isolate	1	Decal	Adhésif	Adhesivo



820 860 880
TX760B TX860B
TX870B

801 803 805 807 813 815 821 823 825 841 843 845 851 853 855

Decals
Adhésifs
Adhesivos

Instructions
Instructions
Instrucciones

C-93020-02.1-C

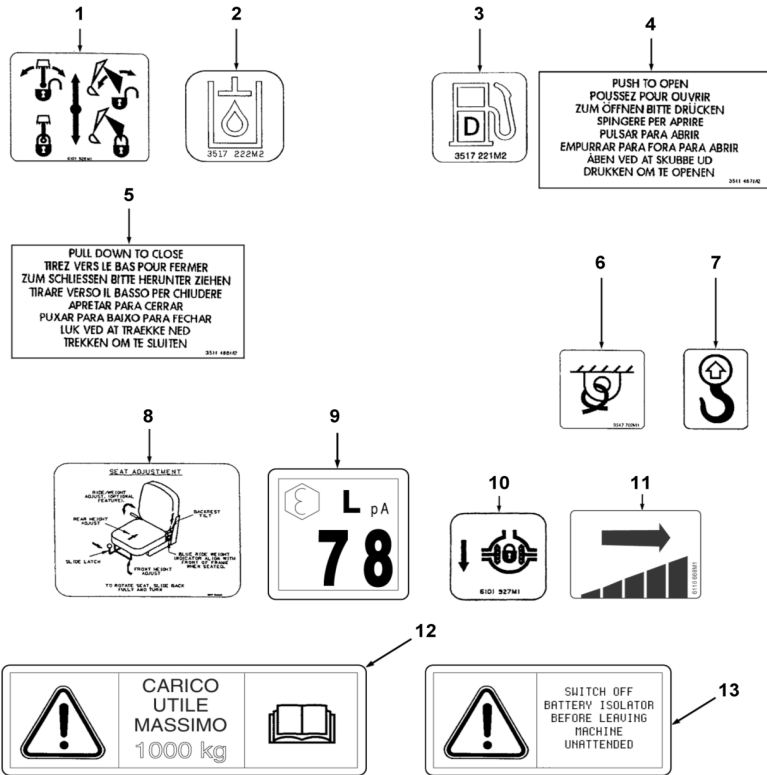

1	6101928M1	Transport Lock	1	Decal	Adhésif	Adhesivo
2	3517222M3	Hydraulic Oil	1	Decal	Adhésif	Adhesivo
3	3517221M3	Diesel Fuel	1	Decal	Adhésif	Adhesivo
4	3511487M2	Push Window	1	Decal	Adhésif	Adhesivo
5	3511488M2	Pull Window	1	Decal	Adhésif	Adhesivo
6	3517702M1	Tie Down	4	Decal	Adhésif	Adhesivo
7	3517703M1	Lifting	4	Decal	Adhésif	Adhesivo
8	6102191M1	Seat Adjust	1	Decal	Adhésif	Adhesivo
9	6009536M1	Noise 78 LPA	1	Decal	Adhésif	Adhesivo
10	6101927M1	Diff Lock	1	Decal	Adhésif	Adhesivo
11	6110668M1	Hand Throttle	1	Decal	Adhésif	Adhesivo
12	6110494M1	Safe Working	2	Decal	Adhésif	Adhesivo
13	6108497M1	Battery Isolate	1	Decal	Adhésif	Adhesivo



820 860 880 970 980
TX760B TX860B

805 807 817 825 845 855 921 931

**Decals
Adhésifs
Adhesivos**

**Instructions
Instructions
Instrucciones**

C-93021-02.1-C

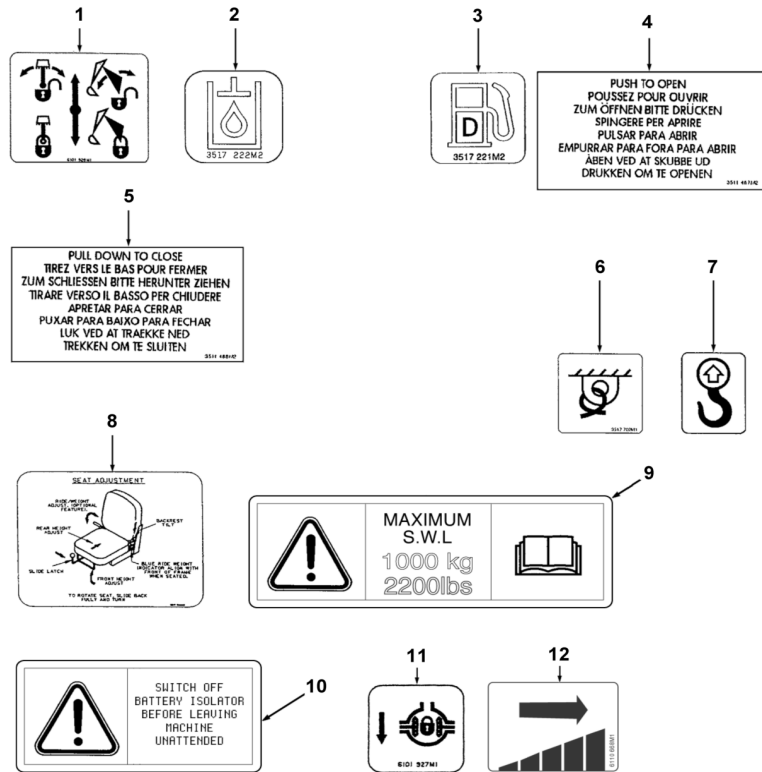

1	6101928M1	Transport Lock	1	Decal	Adhésif	Adhesivo
2	3517222M3	Hydraulic Oil	1	Decal	Adhésif	Adhesivo
3	3517221M3	Diesel Fuel	1	Decal	Adhésif	Adhesivo
4	3511487M2	Push Window	1	Decal	Adhésif	Adhesivo
5	3511488M2	Pull Window	1	Decal	Adhésif	Adhesivo
6	3517702M1	Tie Down	4	Decal	Adhésif	Adhesivo
7	3517703M1	Lifting	4	Decal	Adhésif	Adhesivo
8	6102191M1	Seat Adjust	1	Decal	Adhésif	Adhesivo
9	6102194M1	Safe Working	2	Decal	Adhésif	Adhesivo
10	6108495M1	Battery Isolator	1	Decal	Adhésif	Adhesivo
11	6101927M1	Diff Lock	1	Decal	Adhésif	Adhesivo
12	6110668M1	Hand Throttle	1	Decal	Adhésif	Adhesivo



820 860 880 970 980
TX760B TX860B
TX870B TX970B

801 803 805 807 813 815 817 821 823 825 841 843 845 851 853 855 921 922 923
931 932

**Decals
Adhésifs
Adhesivos**

**Instructions
Instructions
Instrucciones**

C-93022-02.1-B

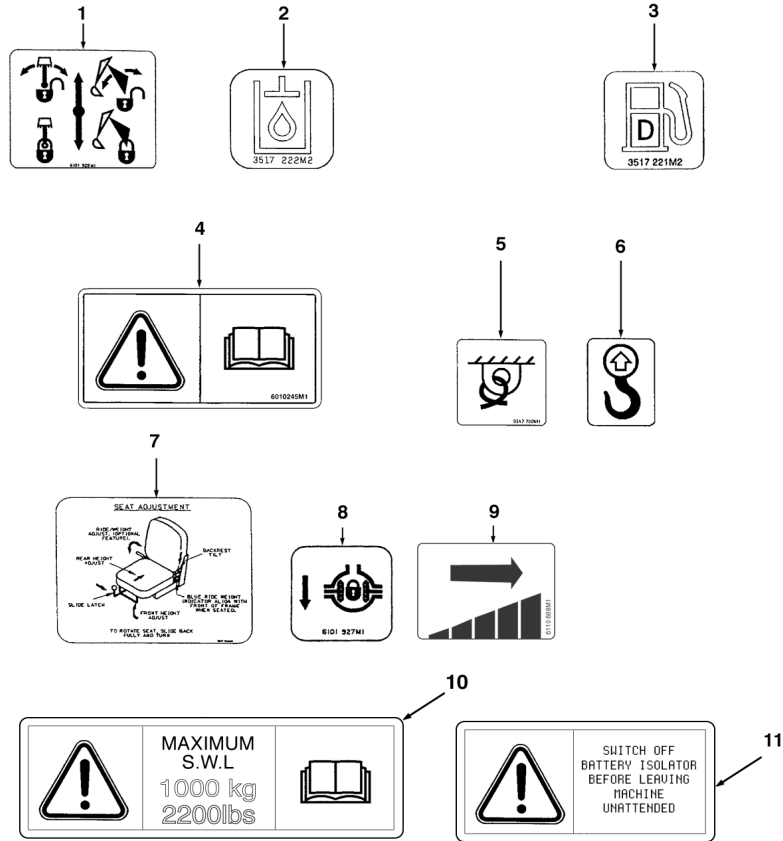

1	6101928M1	Transport Lock	1	Decal	Adhésif	Adhesivo
2	3517222M3	Hydraulic Oil	1	Decal	Adhésif	Adhesivo
3	3517221M3	Diesel Fuel	1	Decal	Adhésif	Adhesivo
4	6108692M1	Read O.I.B.	1	Decal	Adhésif	Adhesivo
5	3517702M1	Tie Down	4	Decal	Adhésif	Adhesivo
6	3517703M1	Lifting	4	Decal	Adhésif	Adhesivo
7	6102191M1	Seat Adjust	1	Decal	Adhésif	Adhesivo
8	6101927M1	Diff Lock	1	Decal	Adhésif	Adhesivo
9	6110668M1	Hand Throttle	1	Decal	Adhésif	Adhesivo
10	6102194M1	Safe Working	2	Decal	Adhésif	Adhesivo
11	6108495M1	Battery Isolate	1	Decal	Adhésif	Adhesivo



820 860 880
TX760B TX860B
TX870B

802 804 806 808 814 816 822 824 842 844 852 854

Not Illustrated

Non Illustrée

Nicht Abgebildet

Non Illustrato

No Ilustrado

1	6101928M1	Transport Lock	1	Decal	Adhésif	Adhesivo
2	3517222M3	Hydraulic Oil	1	Decal	Adhésif	Adhesivo
3	3517221M3	Diesel Fuel	1	Decal	Adhésif	Adhesivo
4	3511487M2	Push Window	1	Decal	Adhésif	Adhesivo
5	3511488M2	Pull Window	1	Decal	Adhésif	Adhesivo
6	3517702M1	Tie Down	4	Decal	Adhésif	Adhesivo
7	3517703M1	Lifting	4	Decal	Adhésif	Adhesivo
8	6102191M1	Seat Adjust	1	Decal	Adhésif	Adhesivo
9	6009536M1	Noise 78 LPA	1	Decal	Adhésif	Adhesivo
10	6101927M1	Diff Lock	1	Decal	Adhésif	Adhesivo
11	6110668M1	Hand Throttle	1	Decal	Adhésif	Adhesivo
12	6102194M1	Safe Working	2	Decal	Adhésif	Adhesivo
13	6108496M1	Battery Isolate	1	Decal	Adhésif	Adhesivo



880 980
TX860B

845 855 931

Decals
Adhésifs
Adhesivos

Machine Identity
Identification Machine
Identificación de máquina

C-92001-01.1-A

1	6107978M91	Front Grille	1	Emblem	Emblème	Emblema
2	6100457M1		2	Fastener	Attache	Eganche
3	6110279M1	820	2	Decal	Adhésif	Adhesivo
4	6109331M1	◀ TCE	2	Decal	Adhésif	Adhesivo
4	6109332M1	▶ TCE	2	Decal	Adhésif	Adhesivo

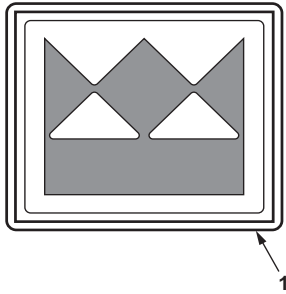

820
TX760B

801 802 803 804 805 806 807 808

Decals
Adhésifs
Adhesivos

Machine Identity
Identification Machine
Identificación de máquina

C-92002-01.1-A

1	6107978M91	Front Grille	1	Emblem	Emblème	Emblema
2	6100457M1		2	Fastener	Attache	Eganche
3	6110281M1	860SX	2	Decal	Adhésif	Adhesivo
4	6109331M1	◀ TCE	2	Decal	Adhésif	Adhesivo
4	6109332M1	▶ TCE	2	Decal	Adhésif	Adhesivo

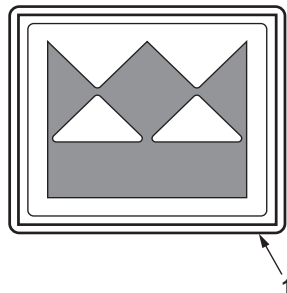

860
TX860B TX870B

813 814 815 816 817 821 822 825

Decals
Adhésifs
Adhesivos

Machine Identity
Identification Machine
Identificación de máquina

C-92003-01.1-B

1	6107978M91	Front Grille	1	Emblem	Emblème	Emblema
2	6100457M1		2	Fastener	Attache	Enganche
3	6110280M1	860	2	Decal	Adhésif	Adhesivo
4	6109331M1	◀ TCE	2	Decal	Adhésif	Adhesivo
4	6109332M1	▶ TCE	2	Decal	Adhésif	Adhesivo
5	6109359M1	Elite	2	Decal	Adhésif	Adhesivo
6	6106693M1	Powershift	2	Decal	Adhésif	Adhesivo

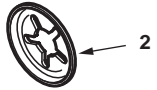
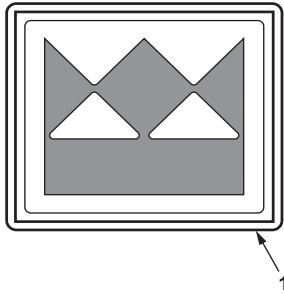

860
TX860B TX870B

821 822 823 824 825

Decals
Adhésifs
Adhesivos

Machine Identity
Identification Machine
Identificación de máquina

C-92004-01.1-B

1	6107978M91	Front Grille	1	Emblem	Emblème	Emblema
2	6100457M1		2	Fastener	Attache	Enganche
3	6110282M1	970	2	Decal	Adhésif	Adhesivo
4	6109331M1	◀ TCE	2	Decal	Adhésif	Adhesivo
4	6109332M1	▶ TCE	2	Decal	Adhésif	Adhesivo
5	6109359M1	Elite	2	Decal	Adhésif	Adhesivo
6	6106693M1	Powershift	2	Decal	Adhésif	Adhesivo

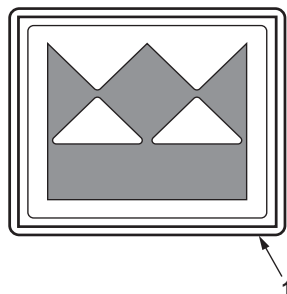

970 980
TX970B

921 922 923 931 932

**Decals
Adhésifs
Adhesivos**

**Machine Identity
Identification Machine
Identificación de máquina**

C-92005-01.1-A

1	6107978M91	Front Grille	1	Emblem	Emblème	Emblema
2	6100457M1		2	Fastener	Attache	Enganche
3	6110279M1	820	2	Decal	Adhésif	Adhesivo
4	6100419M2	Fermec L/Arm	2	Decal	Adhésif	Adhesivo
5	6100420M2	Fermec Boom	2	Decal	Adhésif	Adhesivo

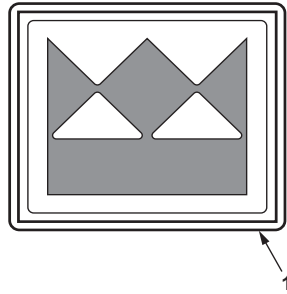

820
TX760B

801 802 803 804 805 806 807 808

Decals
Adhésifs
Adhesivos

Machine Identity
Identification Machine
Identificación de máquina

C-92006-01.1-A

1	6107978M91	Front Grille	1	Emblem	Emblème	Emblema
2	6100457M1		2	Fastener	Attache	Enganche
3	6110281M1	860SX	2	Decal	Adhésif	Adhesivo
4	6100419M2	Fermec L/Arm	2	Decal	Adhésif	Adhesivo
5	6100420M2	Fermec Boom	2	Decal	Adhésif	Adhesivo

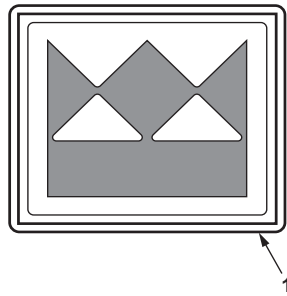

860
TX860B TX870B

813 814 815 816 817

Decals
Adhésifs
Adhesivos

Machine Identity
Identification Machine
Identificación de máquina

C-92007-01.1-B

1	6107978M91	Front Grille	1	Emblem	Emblème	Emblema
2	6100457M1		2	Fastener	Attache	Enganche
3	6110280M1	860	2	Decal	Adhésif	Adhesivo
4	6100419M2	Fermec L/Arm	2	Decal	Adhésif	Adhesivo
5	6100420M2	Fermec Boom	2	Decal	Adhésif	Adhesivo
6	6109359M1	Elite	2	Decal	Adhésif	Adhesivo
7	6106693M1	Powershift	2	Decal	Adhésif	Adhesivo

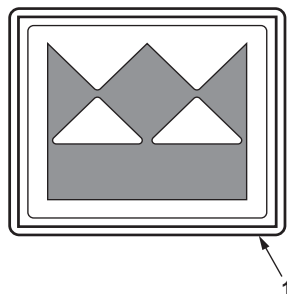

860
TX860B TX870B

821 822 823 824 825

Decals
Adhésifs
Adhesivos

Machine Identity
Identification Machine
Identificación de máquina

C-92009-01.1-A

1	6107978M91	Front Grille	1	Emblem	Emblème	Emblema
2	6100457M1		2	Fastener	Attache	Enganche
3	6110273M1	TX760B	2	Decal	Adhésif	Adhesivo
4	6110287M1	◀ Terex Boom	1	Decal	Adhésif	Adhesivo
4	6110276M1	▶ Terex Boom	1	Decal	Adhésif	Adhesivo
5	6110278M1	◀ Bonnet Flash	1	Decal	Adhésif	Adhesivo
5	6110277M1	▶ Bonnet Flash	1	Decal	Adhésif	Adhesivo

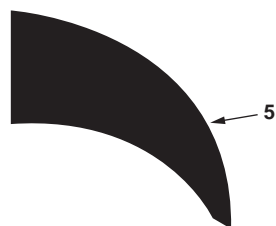
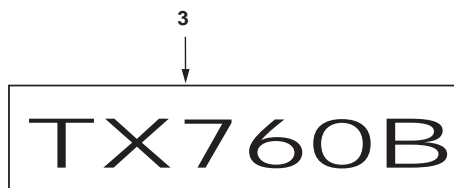
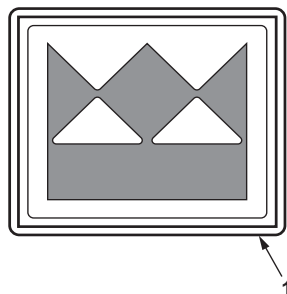

820
TX760B

801 802 803 804 805 806 807 808 831 832 833 834

92009C01.1

6199042M3

1

Jan-06

Decals
Adhésifs
Adhesivos

Machine Identity
Identification Machine
Identificación de máquina

C-92010-01.1-A

1	6107978M91	Front Grille	1	Emblem	Emblème	Emblema
2	6100457M1		2	Fastener	Attache	Enganche
3	6110274M1	TX860B	2	Decal	Adhésif	Adhesivo
4	6110287M1	◀ Terex Boom	1	Decal	Adhésif	Adhesivo
4	6110276M1	▶ Terex Boom	1	Decal	Adhésif	Adhesivo
5	6110278M1	◀ Bonnet Flash	1	Decal	Adhésif	Adhesivo
5	6110277M1	▶ Bonnet Flash	1	Decal	Adhésif	Adhesivo

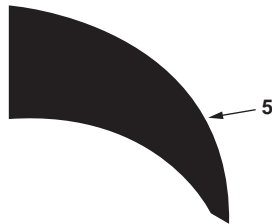
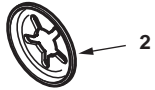
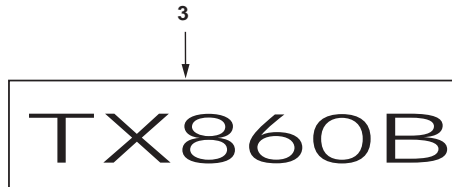
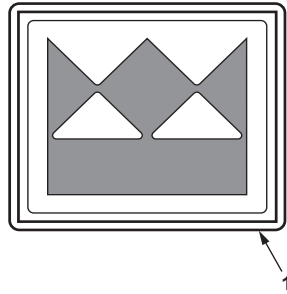

860 880
TX860B TX870B

809 810 813 814 821 822 825 841 842 844

Decals
Adhésifs
Adhesivos

Machine Identity
Identification Machine
Identificación de máquina

C-92011-01.1-A

1	6107978M91	Front Grille	1	Emblem	Emblème	Emblema
2	6100457M1		2	Fastener	Attache	Enganche
3	6110275M1	TX870B	2	Decal	Adhésif	Adhesivo
4	6110287M1	◀ Terex Boom	1	Decal	Adhésif	Adhesivo
4	6110276M1	▶ Terex Boom	1	Decal	Adhésif	Adhesivo
5	6110278M1	◀ Bonnet Flash	1	Decal	Adhésif	Adhesivo
5	6110277M1	▶ Bonnet Flash	1	Decal	Adhésif	Adhesivo

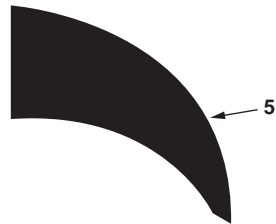
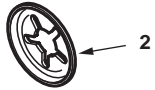
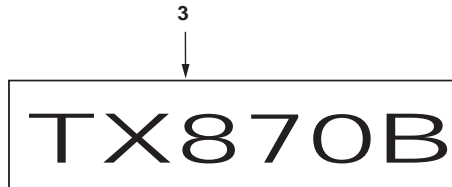
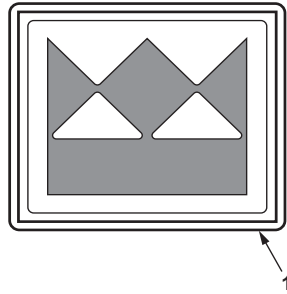

860 880
TX870B

811 812 815 816 823 824 843 844

92011C01.1

6199042M3

1

Jan-06

Decals
Adhésifs
Adhesivos

Machine Identity
Identification Machine
Identificación de máquina

C-92012-01.1-A

1	6107978M91	Front Grille	1	Emblem	Emblème	Emblema
2	6100457M1		2	Fastener	Attache	Enganche
3	6110274M1	TX860B	2	Decal	Adhésif	Adhesivo
4	6110287M1	◀ Terex Boom	1	Decal	Adhésif	Adhesivo
4	6110276M1	▶ Terex Boom	1	Decal	Adhésif	Adhesivo
5	6110278M1	◀ Bonnet Flash	1	Decal	Adhésif	Adhesivo
5	6110277M1	▶ Bonnet Flash	1	Decal	Adhésif	Adhesivo
6	6106693M1	Powershift	2	Decal	Adhésif	Adhesivo

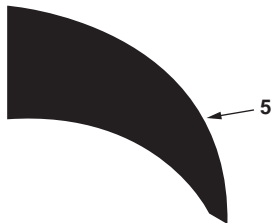
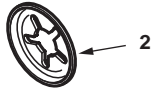
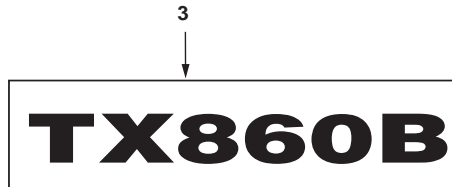
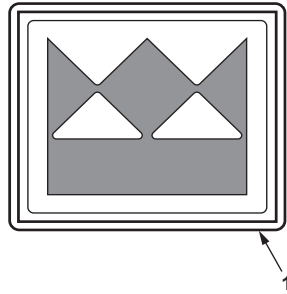

POWERSHIFT



880
TX860B

851 852 855

Decals
Adhésifs
Adhesivos

Machine Identity
Identification Machine
Identificación de máquina

C-92015-01.1-A

1	6107978M91	Front Grille	1	Emblem	Emblème	Emblema
2	6100457M1		2	Fastener	Attache	Eganche
3	6110945M1	880SX	2	Decal	Adhésif	Adhesivo
4	8002-2681	Terex Crown	2	Decal	Adhésif	Adhesivo

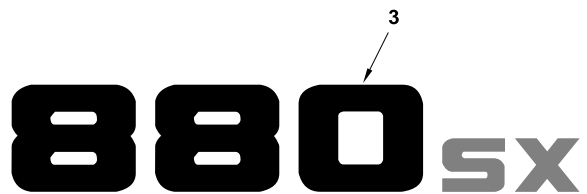
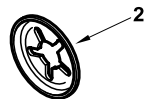
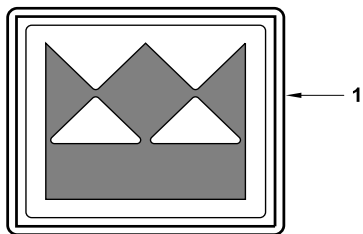

880
TX860B TX870B

841 842 843 844 845

Decals
Adhésifs
Adhesivos

Machine Identity
Identification Machine
Identificación de máquina

C-92016-01.1-A

1	6107978M91	Front Grille	1	Emblem	Emblème	Emblema
2	6100457M1		2	Fastener	Attache	Eganche
3	6110946M1	880 Elite	2	Decal	Adhésif	Adhesivo
4	8002-2681	Terex Crown	2	Decal	Adhésif	Adhesivo

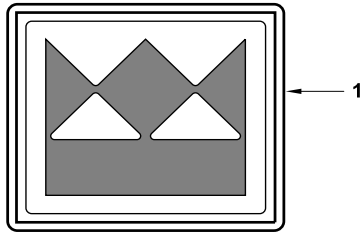

1

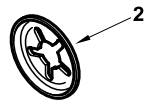

2

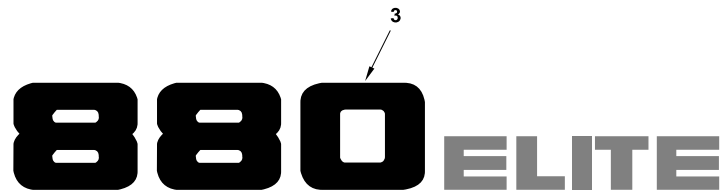

3



4



860 880
TX860B TX870B

817 823 825 842 844 845 851 852 853 854 855

Decals
Adhésifs
Adhesivos

Machine Identity
Identification Machine
Identificación de máquina

C-92017-01.1-A

1	6107978M91	Front Grille	1	Emblem	Emblème	Emblema
2	6100457M1		2	Fastener	Attache	Eganche
3	6110947M1	980 Elite	2	Decal	Adhésif	Adhesivo
4	8002-2681	Terex Crown	2	Decal	Adhésif	Adhesivo

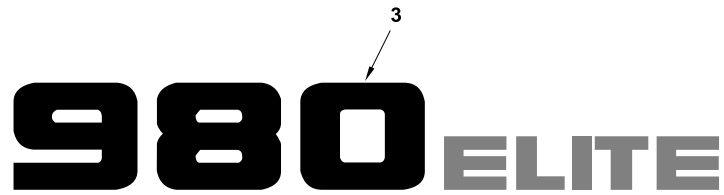
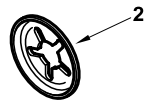
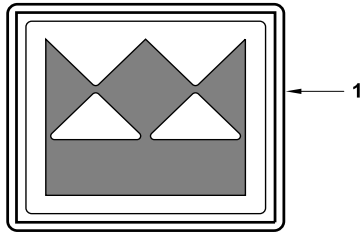

860 880 970 980
TX860B TX870B
TX970B

825 845 851 853 855 921 922 923 931 932

Decals
Adhésifs
Adhesivos

Machine Identity
Identification Machine
Identificación de máquina

C-92018-01.1-A

1	6107978M91	Front Grille	1	Emblem	Emblème	Emblema
2	6100457M1		2	Fastener	Attache	Eganche
3	6110945M1	880SX	2	Decal	Adhésif	Adhesivo
4	6100420M2	Ferrec Boom	2	Decal	Adhésif	Adhesivo

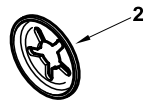
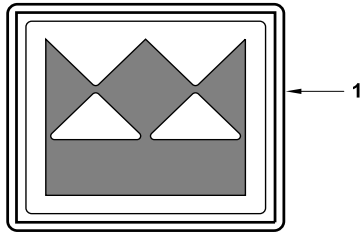

3
880 SX

4
 **FERREC**



880
TX860B TX870B

841 842 843 844 845

Decals
Adhésifs
Adhesivos

Machine Identity
Identification Machine
Identificación de máquina

C-92019-01.1-A

1	6107978M91	Front Grille	1	Emblem	Emblème	Emblema
2	6100457M1		2	Fastener	Attache	Eganche
3	6110946M1	880 Elite	2	Decal	Adhésif	Adhesivo
4	6100420M2	Ferrec Boom	2	Decal	Adhésif	Adhesivo

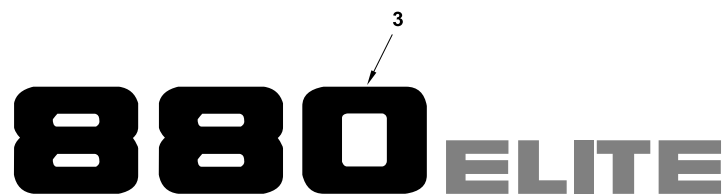
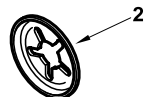
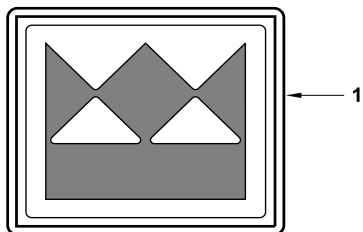

860 880
TX860B TX870B

825 845 851 852 853 854 855

Decals
Adhésifs
Adhesivos

Machine Identity
Identification Machine
Identificación de máquina

C-92020-01.1-A

1	6107978M91	Front Grille	1	Emblem	Emblème	Emblema
2	6100457M1		2	Fastener	Attache	Eganche
3	6110947M1	980 Elite	2	Decal	Adhésif	Adhesivo
4	6100420M2	Ferrec Boom	2	Decal	Adhésif	Adhesivo

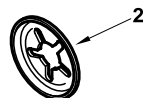
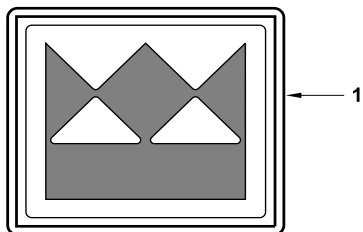

3
980 ELITE

4
 **FERREC**



880 970 980
TX860B TX970B

845 855 921 922 923 931 932

Decals
Adhésifs
Adhesivos

Machine Identity
Identification Machine
Identificación de máquina

1	6109332M1	▶ TCE	1	Decal	Adhésif	Adhesivo
2	6107978M91	Front Grille	1	Emblem	Emblème	Emblema
3	6100457M1		2	Fastener	Attache	Enganche
4	6109331M1	◀ TCE	1	Decal	Adhésif	Adhesivo
5	6110282M1	970	2	Decal	Adhésif	Adhesivo
6	6109359M1	Elite	2	Decal	Adhésif	Adhesivo
7	6106693M1	Powershift	2	Decal	Adhésif	Adhesivo

Not Illustrated

Non Illustrée

Nicht Abgebildet

Non Illustrato

No Ilustrado



970

921

**Decals
Adhésifs
Adhesivos**

**Miscellaneous
Divers
Varios**

C-93001-03.1-A

1	3516906M1	Patent	1	Decal	Adhésif	Adhesivo
2	3516532M1	Serial No. Border	1	Decal	Adhésif	Adhesivo
3	6107927M1	Steering Wheel	1	Cap	Chapeau	Sombrerete

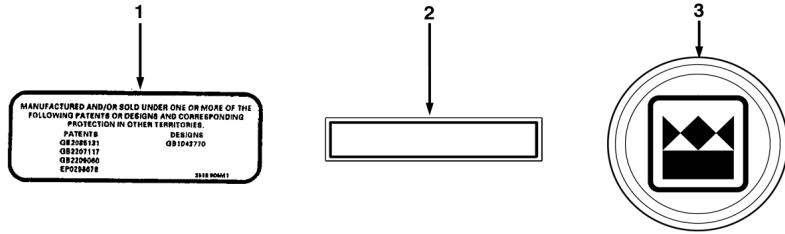

820 860 880 970 980
TX760B TX860B
TX870B TX970B

801 803 805 807 813 815 817 821 823 825 841 843 845 851 853 855 921 922 923
931 932

**Decals
Adhésifs
Adhesivos**

**Miscellaneous
Divers
Varios**

C-93002-03.1-A

1	3516906M1	Patent	1	Decal	Adhésif	Adhesivo
2	3516532M1	Serial No. Border	1	Decal	Adhésif	Adhesivo
3	6107927M1	Steering Wheel	1	Cap	Chapeau	Sombreroete

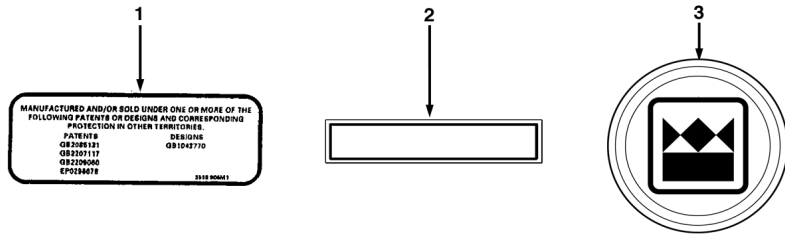

820 860 880 970 980
TX760B TX860B

805 807 817 825 845 855 921 931

**Decals
Adhésifs
Adhesivos**

**Miscellaneous
Divers
Varios**

C-93003-03.1-A

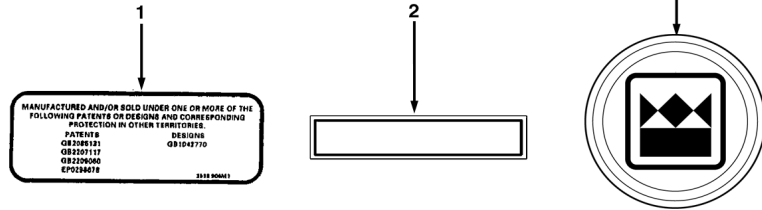

1	3516906M1	Patent	1	Decal	Adhésif	Adhesivo
2	3516532M1	Serial No. Border	1	Decal	Adhésif	Adhesivo
3	6107927M1	Steering Wheel	1	Cap	Chapeau	Sombreroete
4	3509138M1	20 KPH	3	Decal	Adhésif	Adhesivo
5	6106167M1	35 KPH	3	Decal	Adhésif	Adhesivo
6	1532083C1	40 KPH	3	Decal	Adhésif	Adhesivo
7	1470972M1		1	Pad, Anti Slip	Plaque, anti-dérapant	Cinta antideslizante
8	1462768M1		6	Reflector	Catadioptré	Reflector

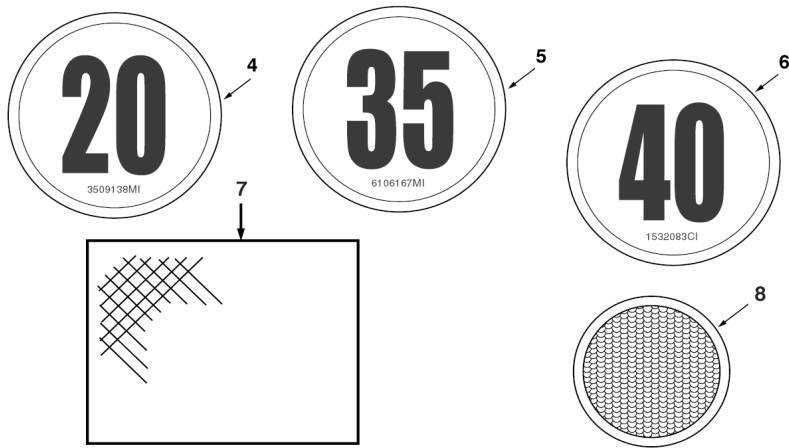

820 860 880
TX760B TX860B

805 807 817 825 845 855

**Decals
Adhésifs
Adhesivos**

**Miscellaneous
Divers
Varios**

C-93004-03.1-B

1	3516906M1	Patent	1	Decal	Adhésif	Adhesivo
2	3516532M1	Serial No. Border	1	Decal	Adhésif	Adhesivo
3	6107927M1	Steering Wheel	1	Cap	Chapeau	Sombrerete
4	6102158M1	Light Absorbion	1	Decal	Adhésif	Adhesivo
5	6110677M1	Stab Leg	2	Decal	Adhésif	Adhesivo

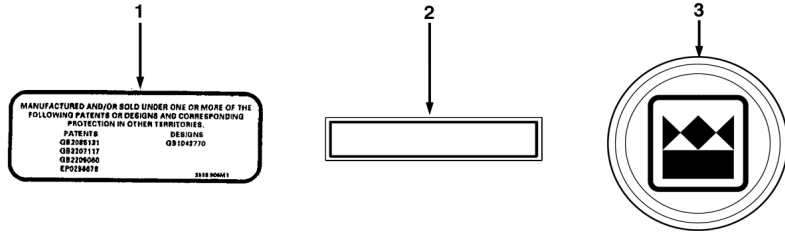

820 860 880 970 980
TX760B TX860B

805 807 817 825 845 855 921 931

**Decals
Adhésifs
Adhesivos**

**Miscellaneous
Divers
Varios**

C-93005-03.1-A

1	3516906M1	Patent	1	Decal	Adhésif	Adhesivo
2	3516532M1	Serial No. Border	1	Decal	Adhésif	Adhesivo
3	6107927M1	Steering Wheel	1	Cap	Chapeau	Sombrerete

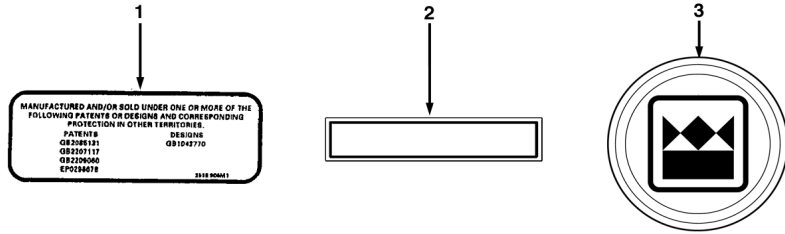

820 860 880 970 980
TX760B TX860B
TX870B TX970B

801 803 805 807 813 815 817 821 823 825 841 842 843 844 845 851 853 855 921
922 923 931 932

**Decals
Adhésifs
Adhesivos**

**Miscellaneous
Divers
Varios**

C-93006-03.1-A

1	3516906M1	Patent	1	Decal	Adhésif	Adhesivo
2	3516532M1	Serial No. Border	1	Decal	Adhésif	Adhesivo
3	6107927M1	Steering Wheel	1	Cap	Chapeau	Sombreroete

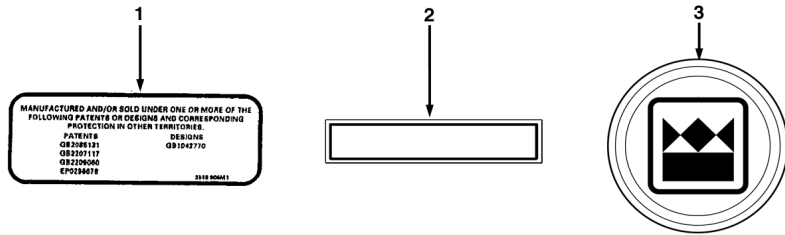

820 860 880
TX760B TX860B
TX870B

802 804 806 808 814 816 822 824 842 844 852 854

**Decals
Adhésifs
Adhesivos**

**Miscellaneous
Divers
Varios**

C-93007-03.1-A

1	3516906M1	Patent	1	Decal	Adhésif	Adhesivo
2	3516532M1	Serial No. Border	1	Decal	Adhésif	Adhesivo
3	6107927M1	Steering Wheel	1	Cap	Chapeau	Sombreroete

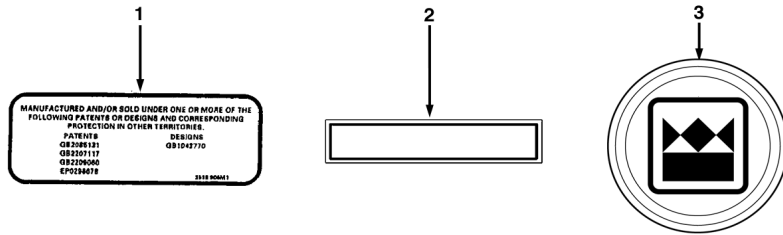

820 860 880 970 980
TX760B TX860B
TX870B

805 807 817 825 843 845 855 921 931

**Decals
Adhésifs
Adhesivos**

**Miscellaneous
Divers
Varios**

C-93008-03.1-A

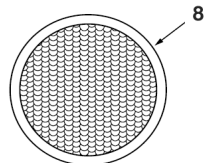
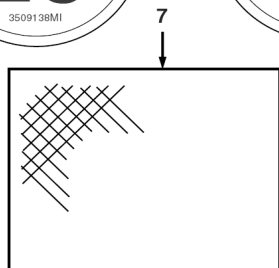
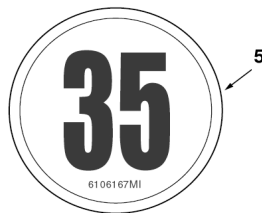
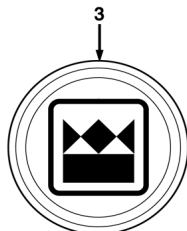
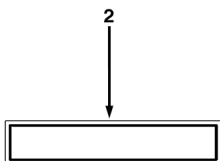
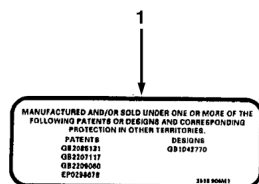

1	3516906M1	Patent	1	Decal	Adhésif	Adhesivo
2	3516532M1	Serial No. Border	1	Decal	Adhésif	Adhesivo
3	6107927M1	Steering Wheel	1	Cap	Chapeau	Sombreroete
4	3509138M1	20 KPH	3	Decal	Adhésif	Adhesivo
5	6106167M1	35 KPH	3	Decal	Adhésif	Adhesivo
6	1532083C1	40 KPH	3	Decal	Adhésif	Adhesivo
7	1470972M1		1	Pad, Anti Slip	Plaque, anti-dérapant	Cinta antideslizante
8	1462768M1		6	Reflector	Catadioptré	Reflector



970 980

921 931

**Decals
Adhésifs
Adhesivos**

**Miscellaneous
Divers
Varios**

C-93009-03.1-A

1	3516906M1	Patent	1	Decal	Adhésif	Adhesivo
2	3516532M1	Serial No. Border	1	Decal	Adhésif	Adhesivo
3	6107927M1	Steering Wheel	1	Cap	Chapeau	Sombreroete

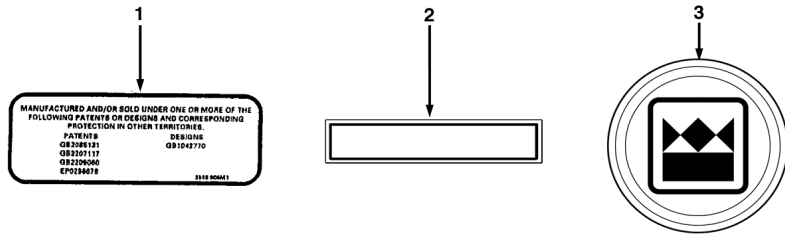

820 860 880 970 980
TX760B TX860B
TX870B

805 807 817 825 843 845 855 921 931

**Decals
Adhésifs
Adhesivos**

**Miscellaneous
Divers
Varios**

C-93010-03.1-A

1	3516906M1	Patent	1	Decal	Adhésif	Adhesivo
2	3516532M1	Serial No. Border	1	Decal	Adhésif	Adhesivo
3	6107927M1	Steering Wheel	1	Cap	Chapeau	Sombreroete

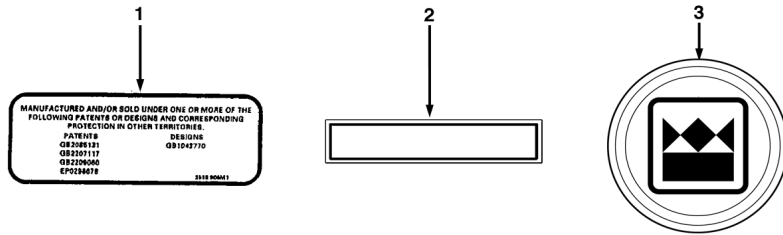

820 860 880 970 980
TX760B TX860B
TX870B

805 807 817 825 843 845 855 921 931

**Decals
Adhésifs
Adhesivos**

**Miscellaneous
Divers
Varios**

C-93011-03.1-A

1	3516906M1	Patent	1	Decal	Adhésif	Adhesivo
2	3516532M1	Serial No. Border	1	Decal	Adhésif	Adhesivo
3	6107927M1	Steering Wheel	1	Cap	Chapeau	Sombreroete

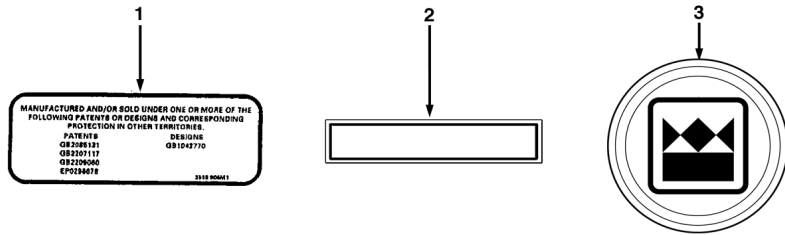

820 860 880
TX760B TX860B
TX870B

802 804 806 808 814 816 822 824 842 844 852 854

**Decals
Adhésifs
Adhesivos**

**Miscellaneous
Divers
Varios**

C-93012-03.1-A

1	3516906M1	Patent	1	Decal	Adhésif	Adhesivo
2	3516532M1	Serial No. Border	1	Decal	Adhésif	Adhesivo
3	6107927M1	Steering Wheel	1	Cap	Chapeau	Sombreroete

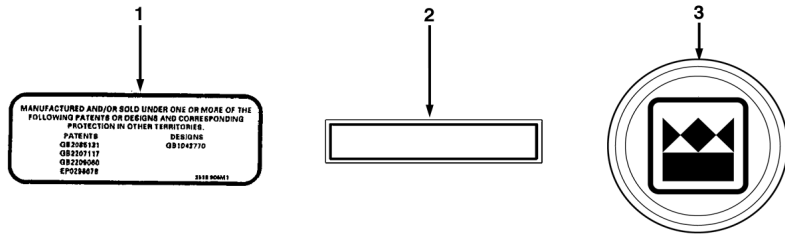

820 860 880 970 980
TX760B TX860B

805 807 817 825 845 855 921 931

**Decals
Adhésifs
Adhesivos**

**Miscellaneous
Divers
Varios**

C-93013-03.1-A

1	3516906M1	Patent	1	Decal	Adhésif	Adhesivo
2	3516532M1	Serial No. Border	1	Decal	Adhésif	Adhesivo
3	6107927M1	Steering Wheel	1	Cap	Chapeau	Sombreroete

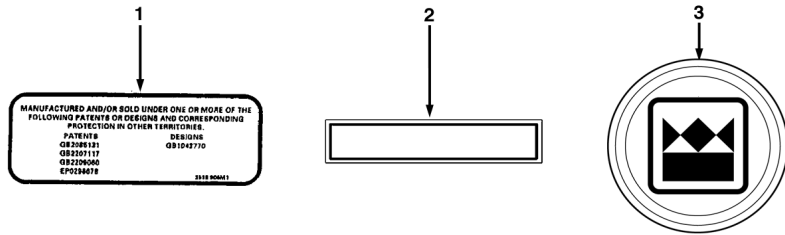

820 860 880
TX760B TX860B
TX870B

802 804 806 808 810 812 814 816 822 824 832 834 842 844 852 854

**Decals
Adhésifs
Adhesivos**

**Miscellaneous
Divers
Varios**

C-93014-03.1-A

1	3516906M1	Patent	1	Decal	Adhésif	Adhesivo
2	3516532M1	Serial No. Border	1	Decal	Adhésif	Adhesivo
3	6107927M1	Steering Wheel	1	Cap	Chapeau	Sombrerete

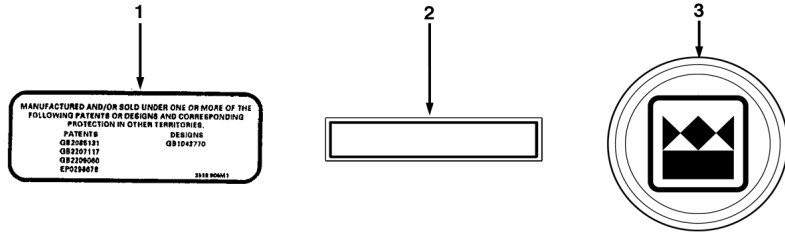

820 860 880
TX760B TX860B
TX870B

801 803 805 807 809 811 813 815 821 823 825 831 833 841 843 851 853 855

**Decals
Adhésifs
Adhesivos**

**Miscellaneous
Divers
Varios**

C-93015-03.1-A

1	3516906M1	Patent	1	Decal	Adhésif	Adhesivo
2	3516532M1	Serial No. Border	1	Decal	Adhésif	Adhesivo
3	6107927M1	Steering Wheel	1	Cap	Chapeau	Sombreroete

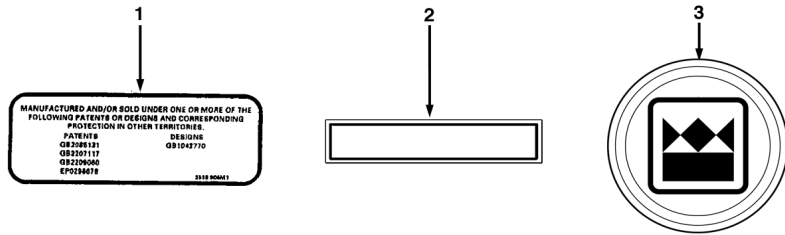

820 860 880
TX760B TX860B
TX870B

801 803 805 807 813 815 817 821 823 825 841 843 845 851 853 855

**Decals
Adhésifs
Adhesivos**

**Miscellaneous
Divers
Varios**

C-93016-03.1-A

1	3516906M1	Patent	1	Decal	Adhésif	Adhesivo
2	3516532M1	Serial No. Border	1	Decal	Adhésif	Adhesivo
3	6107927M1	Steering Wheel	1	Cap	Chapeau	Sombreroete

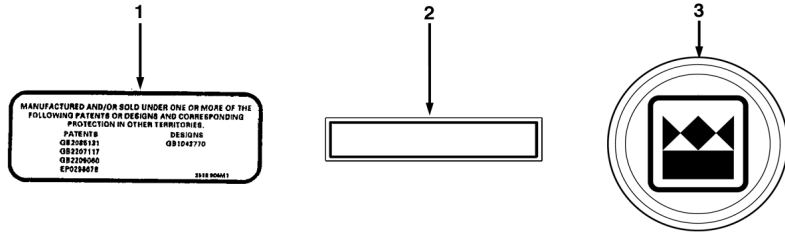

820 860 880
TX760B TX860B
TX870B

802 804 806 808 814 816 822 824 842 844 852 854

**Decals
Adhésifs
Adhesivos**

**Miscellaneous
Divers
Varios**

C-93017-03.1-A

1	3516906M1	Patent	1	Decal	Adhésif	Adhesivo
2	3516532M1	Serial No. Border	1	Decal	Adhésif	Adhesivo
3	6107927M1	Steering Wheel	1	Cap	Chapeau	Sombrerete

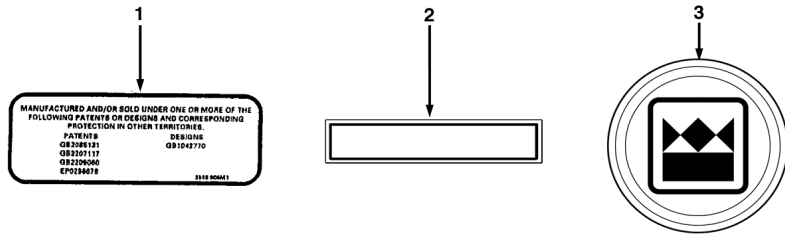

820 860 880
TX760B TX860B
TX870B

802 804 806 808 814 816 822 824 842 844 852 854

**Decals
Adhésifs
Adhesivos**

**Miscellaneous
Divers
Varios**

C-93018-03.1-A

1	3516906M1	Patent	1	Decal	Adhésif	Adhesivo
2	3516532M1	Serial No. Border	1	Decal	Adhésif	Adhesivo
3	6107927M1	Steering Wheel	1	Cap	Chapeau	Sombreroete

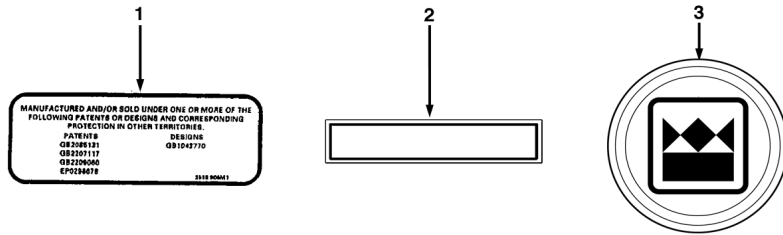

820 860 880
TX760B TX860B
TX870B

801 803 805 807 813 815 821 823 825 841 843 845 851 853 855

Decals
Adhésifs
Adhesivos

Miscellaneous
Divers
Varios

French
Français
Francés

C-93019-01.1-A

1	6110003M1		2	Decal	Adhésif	Adhesivo
---	-----------	--	---	-------	---------	----------

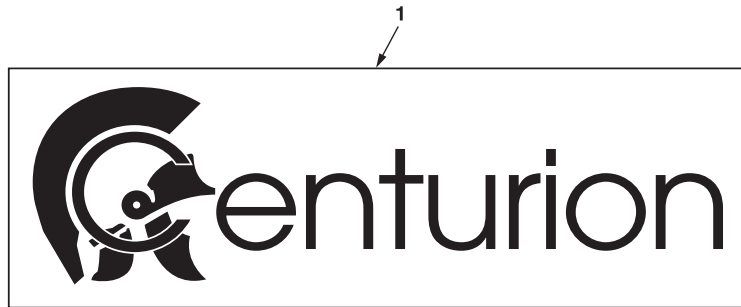

820 860 970
TX760B TX860B

805 807 817 921

93019C01.1

6199042M3

1

Jan-06

**Decals
Adhésifs
Adhesivos**

**Miscellaneous
Divers
Varios**

C-93020-03.1-B

1	3516906M1	Patent	1	Decal	Adhésif	Adhesivo
2	3516532M1	Serial No. Border	1	Decal	Adhésif	Adhesivo
3	6107927M1	Steering Wheel	1	Cap	Chapeau	Sombrerete
4	6102158M1	Light Absorbion	1	Decal	Adhésif	Adhesivo
5	6110677M1	Stab Leg	2	Decal	Adhésif	Adhesivo

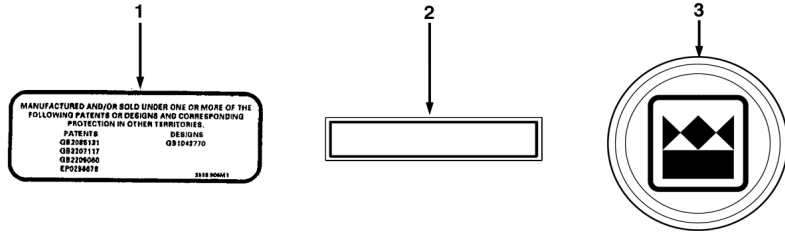

820 860 880 970 980
TX760B TX860B

805 807 817 825 845 855 921 931

**Decals
Adhésifs
Adhesivos**

**Miscellaneous
Divers
Varios**

C-93021-03.1-A

1	3516906M1	Patent	1	Decal	Adhésif	Adhesivo
2	3516532M1	Serial No. Border	1	Decal	Adhésif	Adhesivo
3	6107927M1	Steering Wheel	1	Cap	Chapeau	Sombreroete

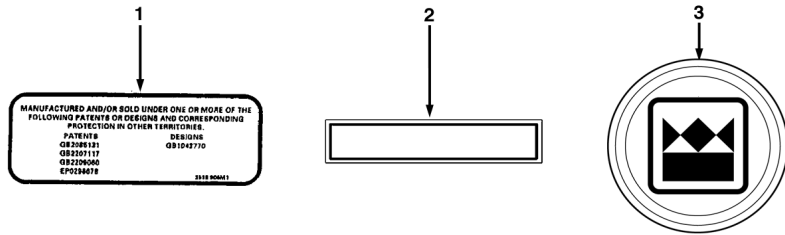

820 860 880 970 980
TX760B TX860B
TX870B TX970B

801 803 805 807 813 815 817 821 823 825 841 843 845 851 853 855 921 922 923
931 932

**Decals
Adhésifs
Adhesivos**

**Miscellaneous
Divers
Varios**

C-93022-03.1-A

1	3516906M1	Patent	1	Decal	Adhésif	Adhesivo
2	3516532M1	Serial No. Border	1	Decal	Adhésif	Adhesivo
3	6107927M1	Steering Wheel	1	Cap	Chapeau	Sombreroete

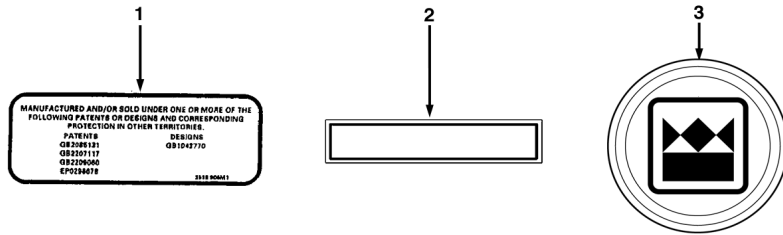

820 860 880
TX760B TX860B
TX870B

802 804 806 808 814 816 822 824 842 844 852 854

**Decals
Adhésifs
Adhesivos**

**Miscellaneous
Divers
Varios**

C-93023-03.1-A

1	3516906M1	Patent	1	Decal	Adhésif	Adhesivo
2	3516532M1	Serial No. Border	1	Decal	Adhésif	Adhesivo
3	6107927M1	Steering Wheel	1	Cap	Chapeau	Sombrerete

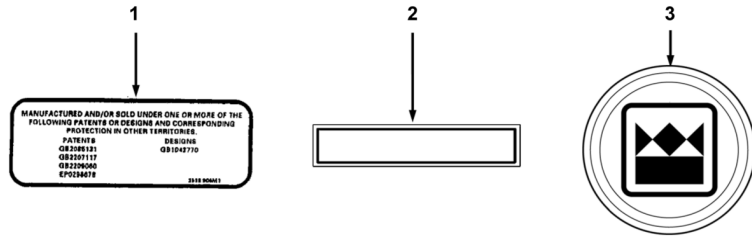

880 980
TX860B

845 855 931

**Decals
Adhésifs
Adhesivos**

**Warnings
Avertissements
Avisos**

C-93001-01.1-A

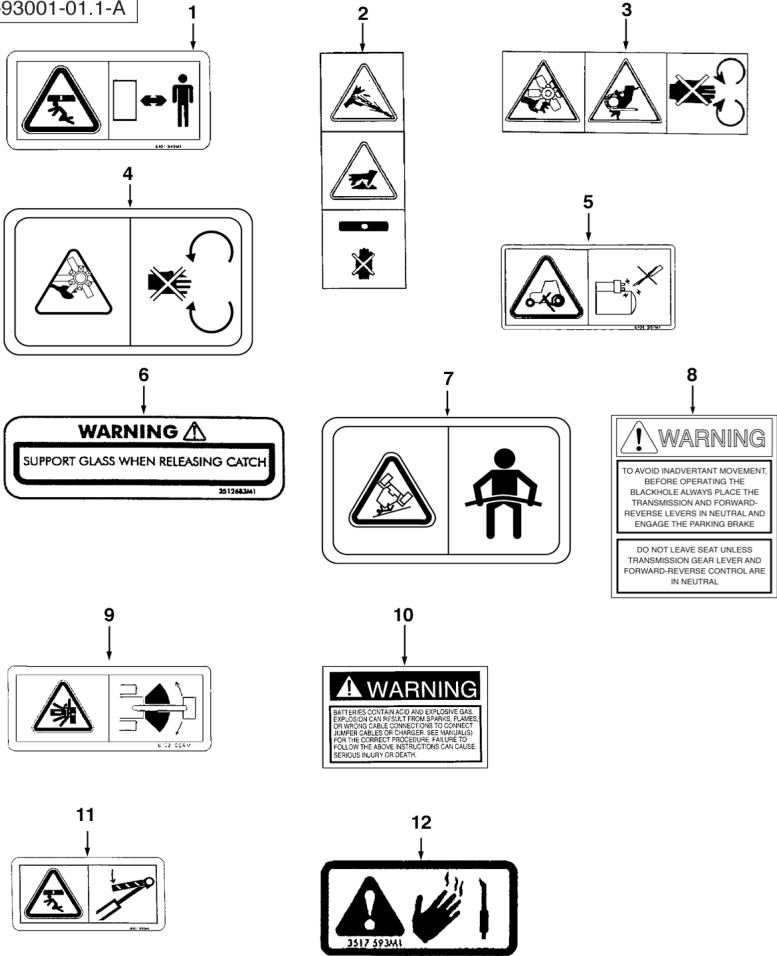

1	6101949M1	Keep Away	4	Decal	Adhésif	Adhesivo
2	6010161M2	Radiator	1	Decal	Adhésif	Adhesivo
3	6010160M2	Fan	2	Decal	Adhésif	Adhesivo
4	6010164M1	Engine Cover	2	Decal	Adhésif	Adhesivo
5	6101951M2	Bypass Start	1	Decal	Adhésif	Adhesivo
6	3512683M1	Support Glass	1	Decal	Adhésif	Adhesivo
7	6101952M2	ROPS Seat Belt	1	Decal	Adhésif	Adhesivo
8	6102184M1	Engage Neutral	1	Decal	Adhésif	Adhesivo
9	6102056M1	Avoid Crushing	2	Decal	Adhésif	Adhesivo
10	321-6714	Battery	1	Decal	Adhésif	Adhesivo
11	6101950M2	Safety Strut	1	Decal	Adhésif	Adhesivo
12	3517593M1	Exhaust	2	Decal	Adhésif	Adhesivo



820 860 880 970 980
TX760B TX860B
TX870B TX970B

801 803 805 807 813 815 817 821 823 825 841 843 845 851 853 855 921 922 923
931 932

**Decals
Adhésifs
Adhesivos**

**Warnings
Avertissements
Avisos**

C-93002-01.1-A

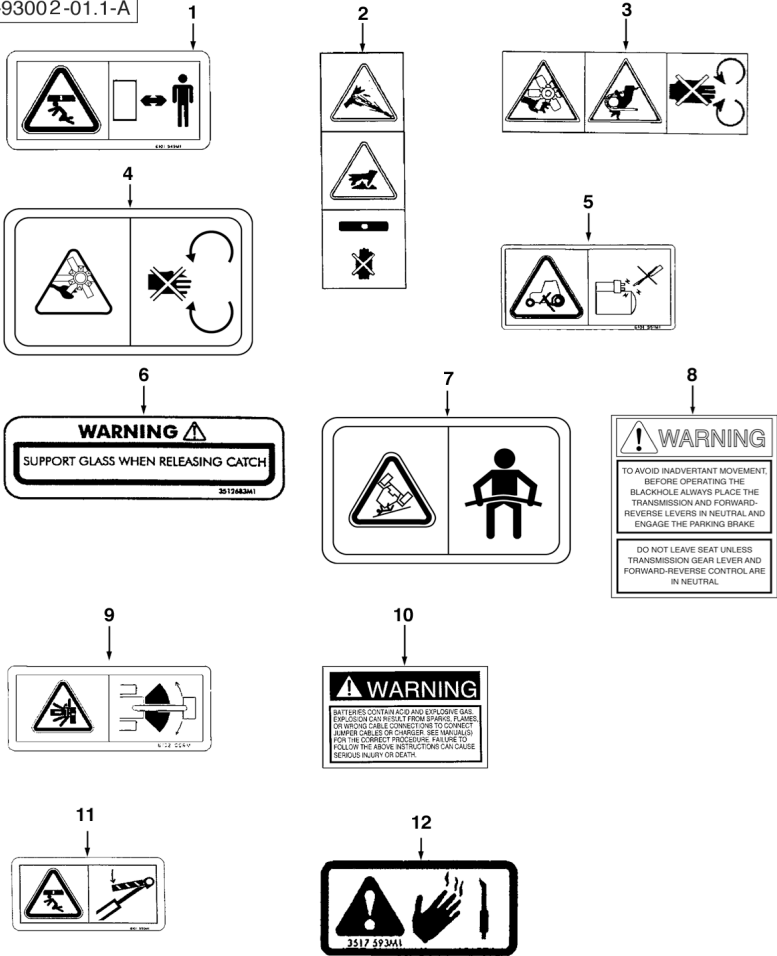

1	6101949M1	Keep Away	4	Decal	Adhésif	Adhesivo
2	6010161M2	Radiator	1	Decal	Adhésif	Adhesivo
3	6010160M2	Fan	2	Decal	Adhésif	Adhesivo
4	6010164M1	Engine Cover	2	Decal	Adhésif	Adhesivo
5	6101951M2	Bypass Start	1	Decal	Adhésif	Adhesivo
6	3512686M1	Support Glass	1	Decal	Adhésif	Adhesivo
7	6101952M2	ROPS Seat Belt	1	Decal	Adhésif	Adhesivo
8	6102185M1	Engage Neutral	1	Decal	Adhésif	Adhesivo
9	6102056M1	Avoid Crushing	2	Decal	Adhésif	Adhesivo
10	321-6719	Battery	1	Decal	Adhésif	Adhesivo
11	6101950M2	Safety Strut	1	Decal	Adhésif	Adhesivo
12	3517593M1	Exhaust	2	Decal	Adhésif	Adhesivo



820 860 880 970 980
TX760B TX860B

805 807 817 825 845 855 921 931

93002C01.1

6199042M3

1

Jan-06

**Decals
Adhésifs
Adhesivos**

**Warnings
Avertissements
Avisos**

C-93003-01.1-A

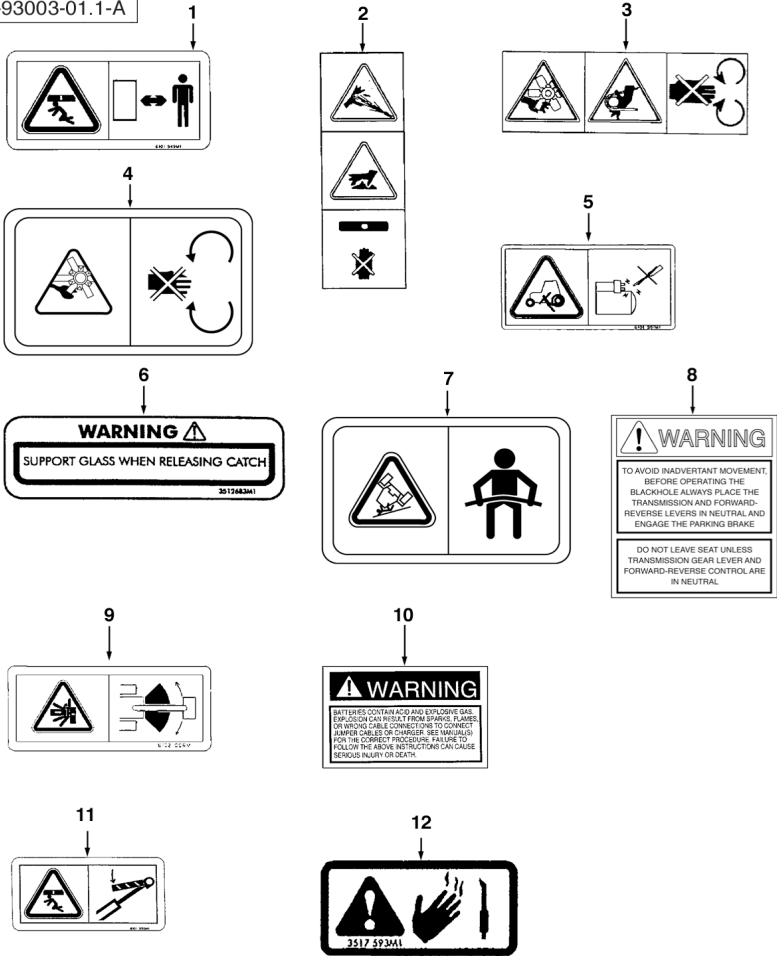

1	6101949M1	Keep Away	4	Decal	Adhésif	Adhesivo
2	6010161M2	Radiator	1	Decal	Adhésif	Adhesivo
3	6010160M2	Fan	2	Decal	Adhésif	Adhesivo
4	6010164M1	Engine Cover	2	Decal	Adhésif	Adhesivo
5	6101951M2	Bypass Start	1	Decal	Adhésif	Adhesivo
6	3512688M1	Support Glass	1	Decal	Adhésif	Adhesivo
7	6101952M2	ROPS Seat Belt	1	Decal	Adhésif	Adhesivo
8	6102186M1	Engage Neutral	1	Decal	Adhésif	Adhesivo
9	6102056M1	Avoid Crushing	2	Decal	Adhésif	Adhesivo
10	321-6724	Battery	1	Decal	Adhésif	Adhesivo
11	6101950M2	Safety Strut	1	Decal	Adhésif	Adhesivo
12	3517593M1	Exhaust	2	Decal	Adhésif	Adhesivo



820 860 880
TX760B TX860B

805 807 817 825 845 855

**Decals
Adhésifs
Adhesivos**

**Warnings
Avertissements
Avisos**

C-93004-01.1-A

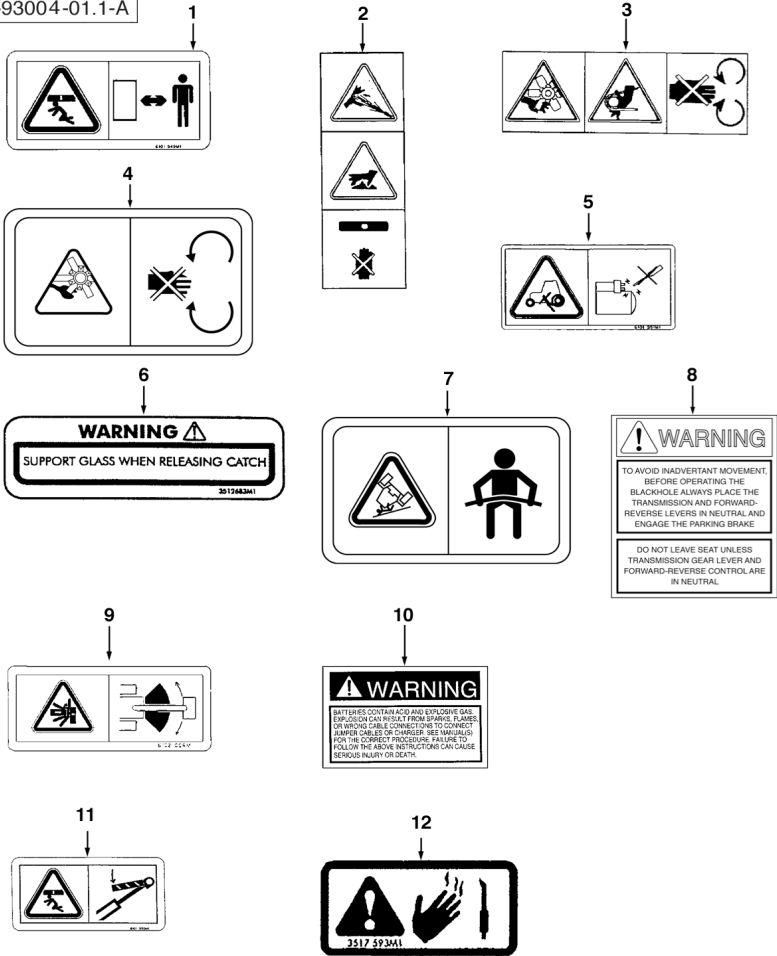

1	6101949M1	Keep Away	4	Decal	Adhésif	Adhesivo
2	6010161M2	Radiator	1	Decal	Adhésif	Adhesivo
3	6010160M2	Fan	2	Decal	Adhésif	Adhesivo
4	6010164M1	Engine Cover	2	Decal	Adhésif	Adhesivo
5	6101951M2	Bypass Start	1	Decal	Adhésif	Adhesivo
6	3512687M1	Support Glass	1	Decal	Adhésif	Adhesivo
7	6101952M2	ROPS Seat Belt	1	Decal	Adhésif	Adhesivo
8	6102190M1	Engage Neutral	1	Decal	Adhésif	Adhesivo
9	6102056M1	Avoid Crushing	2	Decal	Adhésif	Adhesivo
10	321-6750	Battery	1	Decal	Adhésif	Adhesivo
11	6101950M2	Safety Strut	1	Decal	Adhésif	Adhesivo
12	3517593M1	Exhaust	2	Decal	Adhésif	Adhesivo



820 860 880 970 980
TX760B TX860B

805 807 817 825 845 855 921 931

93004C01.1

6199042M3

1

Jan-06

**Decals
Adhésifs
Adhesivos**

**Warnings
Avertissements
Avisos**

C-93005-01.1-A

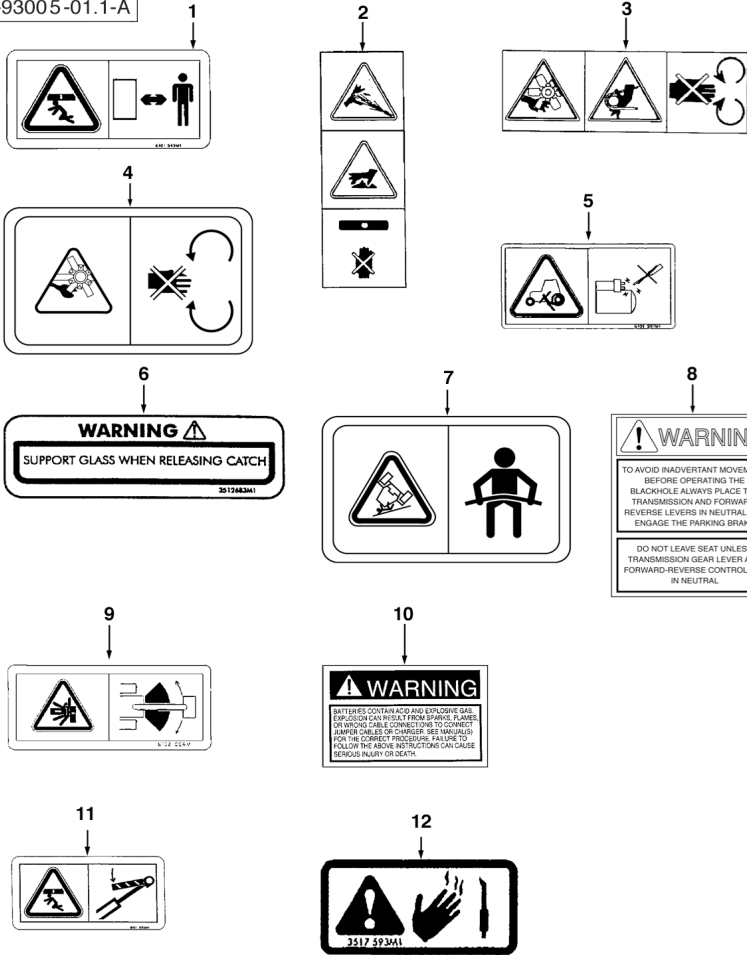

1	6101949M1	Keep Away	4	Decal	Adhésif	Adhesivo
2	6010161M2	Radiator	1	Decal	Adhésif	Adhesivo
3	6010160M2	Fan	2	Decal	Adhésif	Adhesivo
4	6010164M1	Engine Cover	2	Decal	Adhésif	Adhesivo
5	6101951M2	Bypass Start	1	Decal	Adhésif	Adhesivo
6	3512689M2	Support Glass	1	Decal	Adhésif	Adhesivo
7	6101952M2	ROPS Seat Belt	1	Decal	Adhésif	Adhesivo
8	6102187M1	Engage Neutral	1	Decal	Adhésif	Adhesivo
9	6102056M1	Avoid Crushing	2	Decal	Adhésif	Adhesivo
10	321-6722	Battery	1	Decal	Adhésif	Adhesivo
11	6101950M2	Safety Strut	1	Decal	Adhésif	Adhesivo
12	3517593M1	Exhaust	2	Decal	Adhésif	Adhesivo



820 860 880 970 980
TX760B TX860B
TX870B TX970B

801 803 805 807 813 815 817 821 823 825 841 842 843 844 845 851 853 855 921
922 923 931 932

**Decals
Adhésifs
Adhesivos**

**Warnings
Avertissements
Avisos**

C-93006-01.1-A

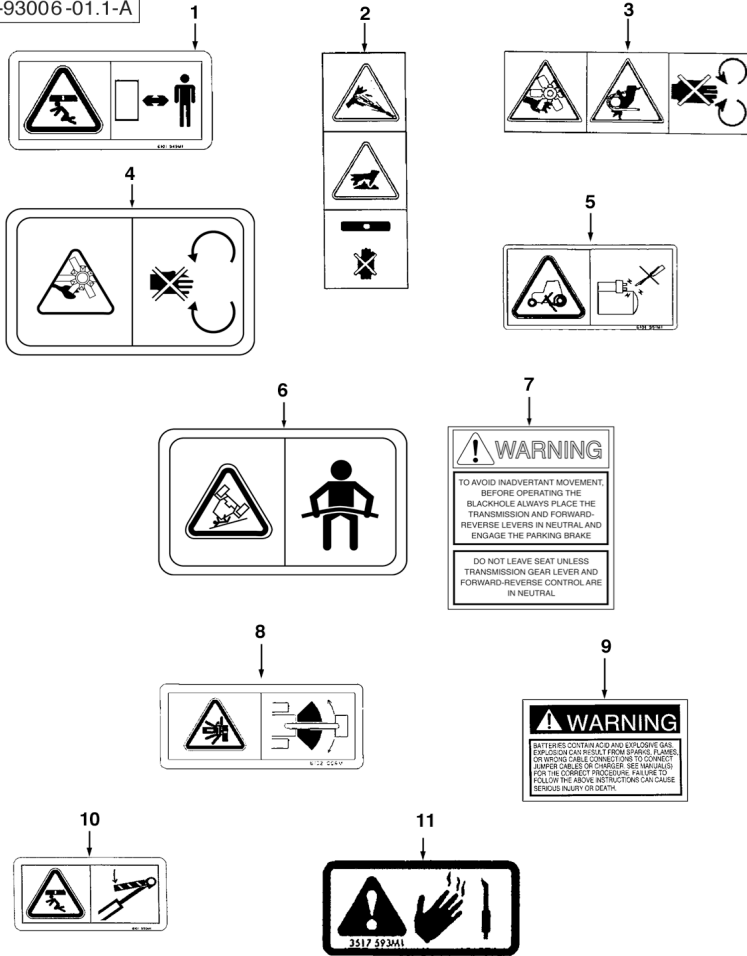

1	6101949M1	Keep Away	4	Decal	Adhésif	Adhesivo
2	6010161M2	Radiator	1	Decal	Adhésif	Adhesivo
3	6010160M2	Fan	2	Decal	Adhésif	Adhesivo
4	6010164M1	Engine Cover	2	Decal	Adhésif	Adhesivo
5	6101951M2	Bypass Start	1	Decal	Adhésif	Adhesivo
6	6101952M2	ROPS Seat Belt	1	Decal	Adhésif	Adhesivo
7	6102184M1	Engage Neutral	1	Decal	Adhésif	Adhesivo
8	6102056M1	Avoid Crushing	2	Decal	Adhésif	Adhesivo
9	321-6714	Battery	1	Decal	Adhésif	Adhesivo
10	6101950M2	Safety Strut	1	Decal	Adhésif	Adhesivo
11	3517593M1	Exhaust	2	Decal	Adhésif	Adhesivo



820 860 880
TX760B TX860B
TX870B

802 804 806 808 814 816 822 824 842 844 852 854

**Decals
Adhésifs
Adhesivos**

**Warnings
Avertissements
Avisos**

C-93007-01.1-A

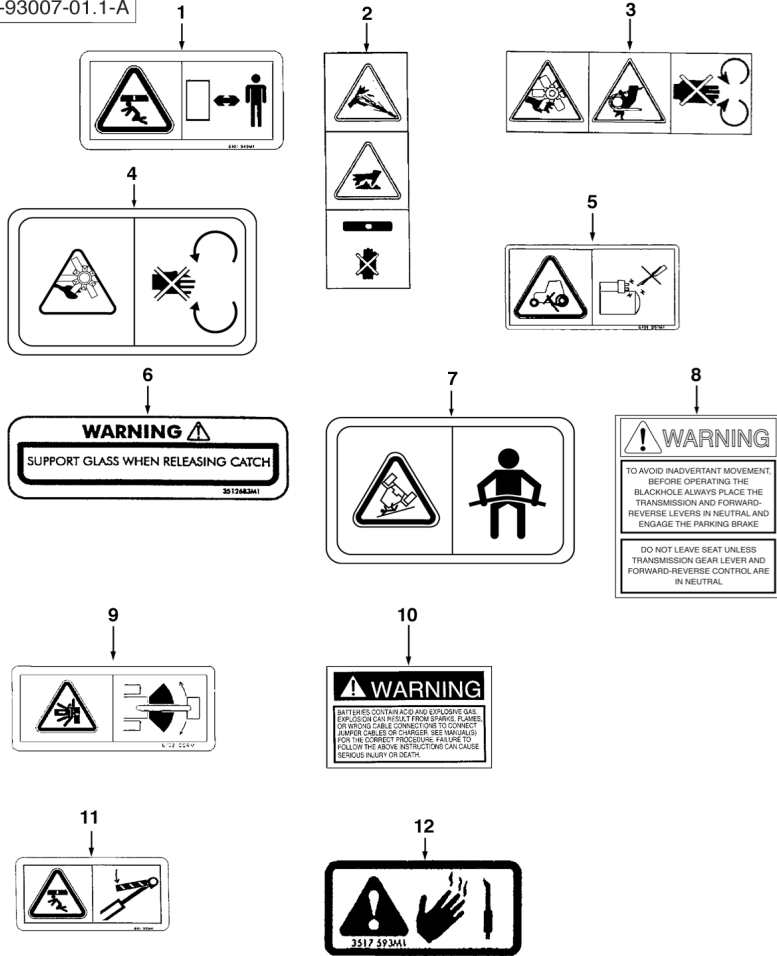

1	6101949M1	Keep Away	4	Decal	Adhésif	Adhesivo
2	6010161M2	Radiator	1	Decal	Adhésif	Adhesivo
3	6010160M2	Fan	2	Decal	Adhésif	Adhesivo
4	6010164M1	Engine Cover	2	Decal	Adhésif	Adhesivo
5	6101951M2	Bypass Start	1	Decal	Adhésif	Adhesivo
6	3512688M1	Support Glass	1	Decal	Adhésif	Adhesivo
7	6101952M2	ROPS Seat Belt	1	Decal	Adhésif	Adhesivo
8	6102186M1	Engage Neutral	1	Decal	Adhésif	Adhesivo
9	6102056M1	Avoid Crushing	2	Decal	Adhésif	Adhesivo
10	321-6724	Battery	1	Decal	Adhésif	Adhesivo
11	6101950M2	Safety Strut	1	Decal	Adhésif	Adhesivo
12	3517593M1	Exhaust	2	Decal	Adhésif	Adhesivo



820 860 880 970 980
TX760B TX860B
TX870B

805 807 817 825 843 845 855 921 931

**Decals
Adhésifs
Adhesivos**

**Warnings
Avertissements
Avisos**

C-93008-01.1-A

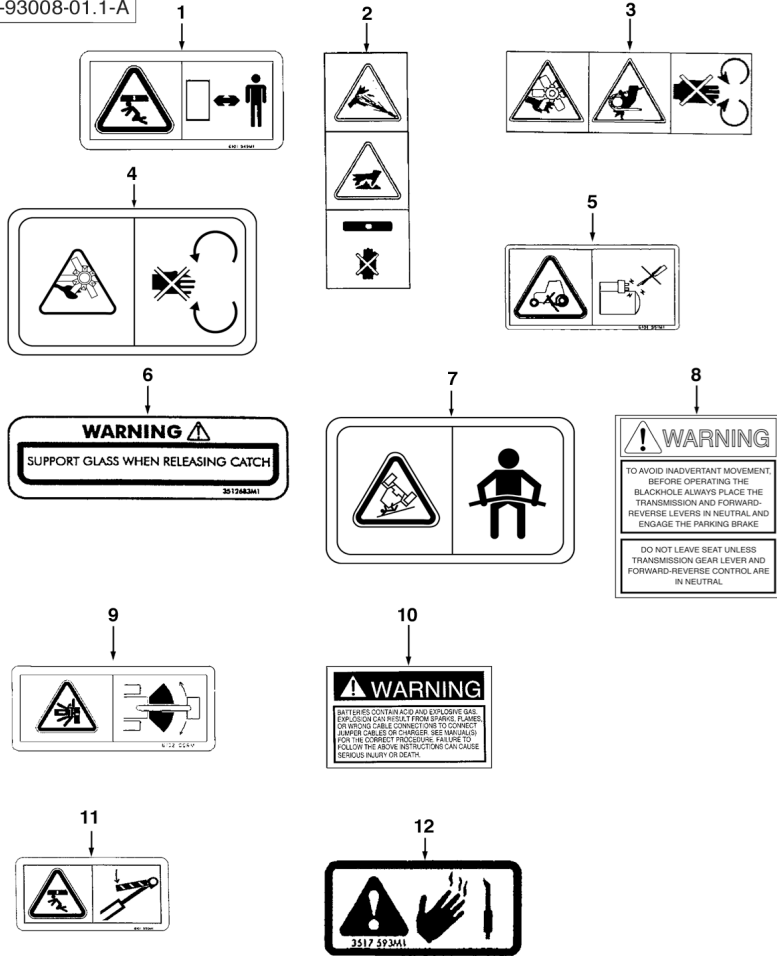

1	6101949M1	Keep Away	4	Decal	Adhésif	Adhesivo
2	6010161M2	Radiator	1	Decal	Adhésif	Adhesivo
3	6010160M2	Fan	2	Decal	Adhésif	Adhesivo
4	6010164M1	Engine Cover	2	Decal	Adhésif	Adhesivo
5	6101951M2	Bypass Start	1	Decal	Adhésif	Adhesivo
6	3512688M1	Support Glass	1	Decal	Adhésif	Adhesivo
7	6101952M2	ROPS Seat Belt	1	Decal	Adhésif	Adhesivo
8	6102186M1	Engage Neutral	1	Decal	Adhésif	Adhesivo
9	6102056M1	Avoid Crushing	2	Decal	Adhésif	Adhesivo
10	321-6724	Battery	1	Decal	Adhésif	Adhesivo
11	6101950M2	Safety Strut	1	Decal	Adhésif	Adhesivo
12	3517593M1	Exhaust	2	Decal	Adhésif	Adhesivo



970 980

921 931

93008C01.1

6199042M3

1

Jan-06

**Decals
Adhésifs
Adhesivos**

**Warnings
Avertissements
Avisos**

C-93009-01.1-A

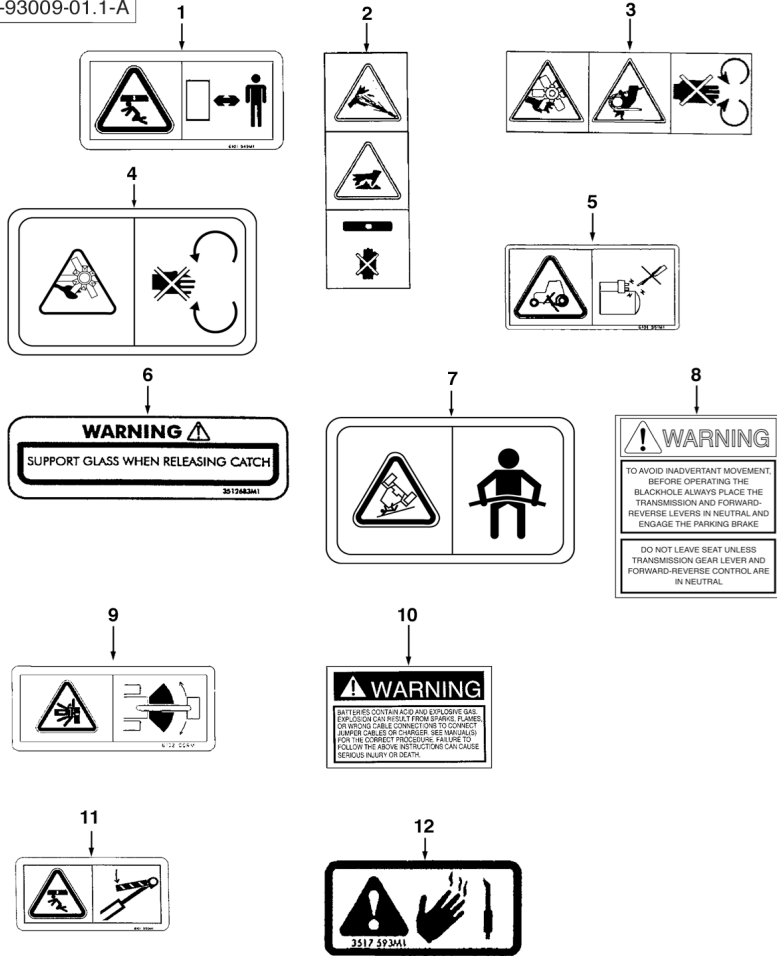

1	6101949M1	Keep Away	4	Decal	Adhésif	Adhesivo
2	6010161M2	Radiator	1	Decal	Adhésif	Adhesivo
3	6010160M2	Fan	2	Decal	Adhésif	Adhesivo
4	6010164M1	Engine Cover	2	Decal	Adhésif	Adhesivo
5	6101951M2	Bypass Start	1	Decal	Adhésif	Adhesivo
6	3517233M1	Support Glass	1	Decal	Adhésif	Adhesivo
7	6101952M2	ROPS Seat Belt	1	Decal	Adhésif	Adhesivo
8	6102188M1	Engage Neutral	1	Decal	Adhésif	Adhesivo
9	6102056M1	Avoid Crushing	2	Decal	Adhésif	Adhesivo
10	229948A1	Battery	1	Decal	Adhésif	Adhesivo
11	6101950M2	Safety Strut	1	Decal	Adhésif	Adhesivo
12	3517593M1	Exhaust	2	Decal	Adhésif	Adhesivo



820 860 880 970 980
TX760B TX860B
TX870B

805 807 817 825 843 845 855 921 931

**Decals
Adhésifs
Adhesivos**

**Warnings
Avertissements
Avisos**

C-93010-01.1-A

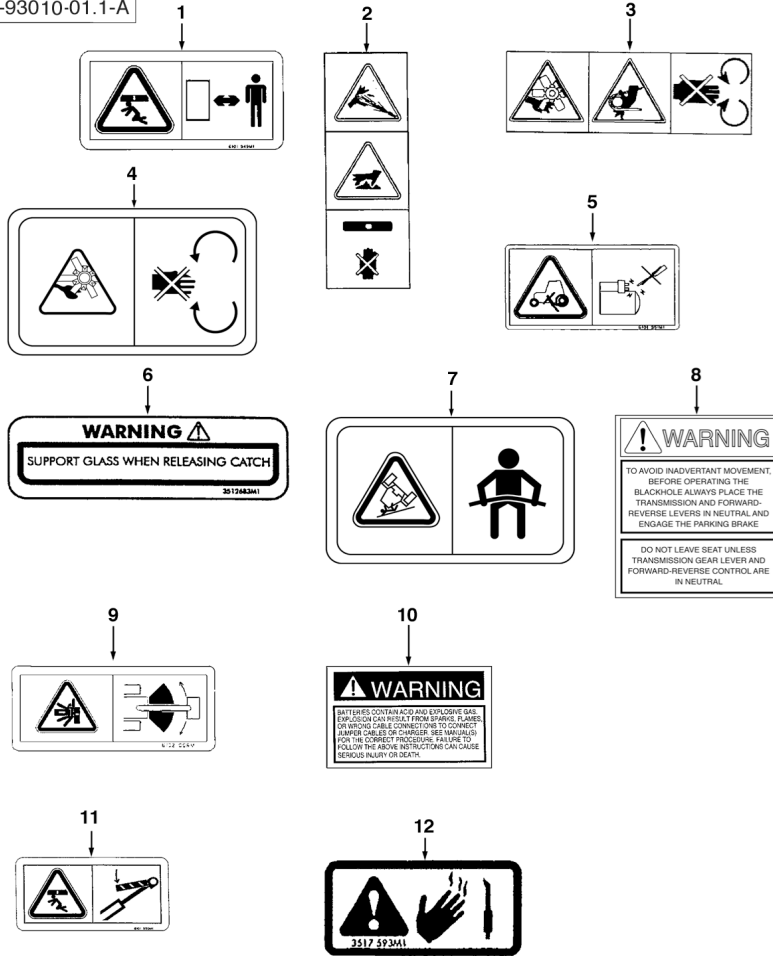

1	6101949M1	Keep Away	4	Decal	Adhésif	Adhesivo
2	6010161M2	Radiator	1	Decal	Adhésif	Adhesivo
3	6010160M2	Fan	2	Decal	Adhésif	Adhesivo
4	6010164M1	Engine Cover	2	Decal	Adhésif	Adhesivo
5	6101951M2	Bypass Start	1	Decal	Adhésif	Adhesivo
6	3517234M1	Support Glass	1	Decal	Adhésif	Adhesivo
7	6101952M2	ROPS Seat Belt	1	Decal	Adhésif	Adhesivo
8	6102189M1	Engage Neutral	1	Decal	Adhésif	Adhesivo
9	6102056M1	Avoid Crushing	2	Decal	Adhésif	Adhesivo
10	321-6754	Battery	1	Decal	Adhésif	Adhesivo
11	6101950M2	Safety Strut	1	Decal	Adhésif	Adhesivo
12	3517593M1	Exhaust	2	Decal	Adhésif	Adhesivo



820 860 880 970 980
TX760B TX860B
TX870B

805 807 817 825 843 845 855 921 931

**Decals
Adhésifs
Adhesivos**

**Warnings
Avertissements
Avisos**

C-93011-01.1-A

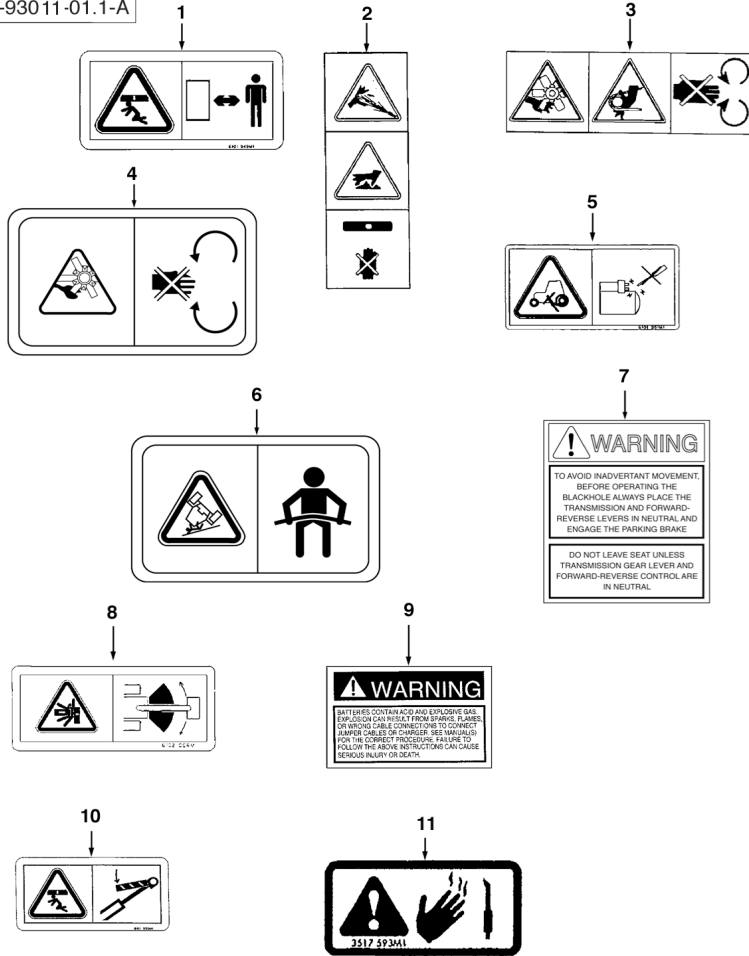

1	6101949M1	Keep Away	4	Decal	Adhésif	Adhesivo
2	6010161M2	Radiator	1	Decal	Adhésif	Adhesivo
3	6010160M2	Fan	2	Decal	Adhésif	Adhesivo
4	6010164M1	Engine Cover	2	Decal	Adhésif	Adhesivo
5	6101951M2	Bypass Start	1	Decal	Adhésif	Adhesivo
6	6101952M2	ROPS Seat Belt	1	Decal	Adhésif	Adhesivo
7	6102187M1	Engage Neutral	1	Decal	Adhésif	Adhesivo
8	6102056M1	Avoid Crushing	2	Decal	Adhésif	Adhesivo
9	321-6722	Battery	1	Decal	Adhésif	Adhesivo
10	6101950M2	Safety Strut	1	Decal	Adhésif	Adhesivo
11	3517593M1	Exhaust	2	Decal	Adhésif	Adhesivo



820 860 880
TX760B TX860B
TX870B

802 804 806 808 814 816 822 824 842 844 852 854

**Decals
Adhésifs
Adhesivos**

**Warnings
Avertissements
Avisos**

C-93012-01.1-A

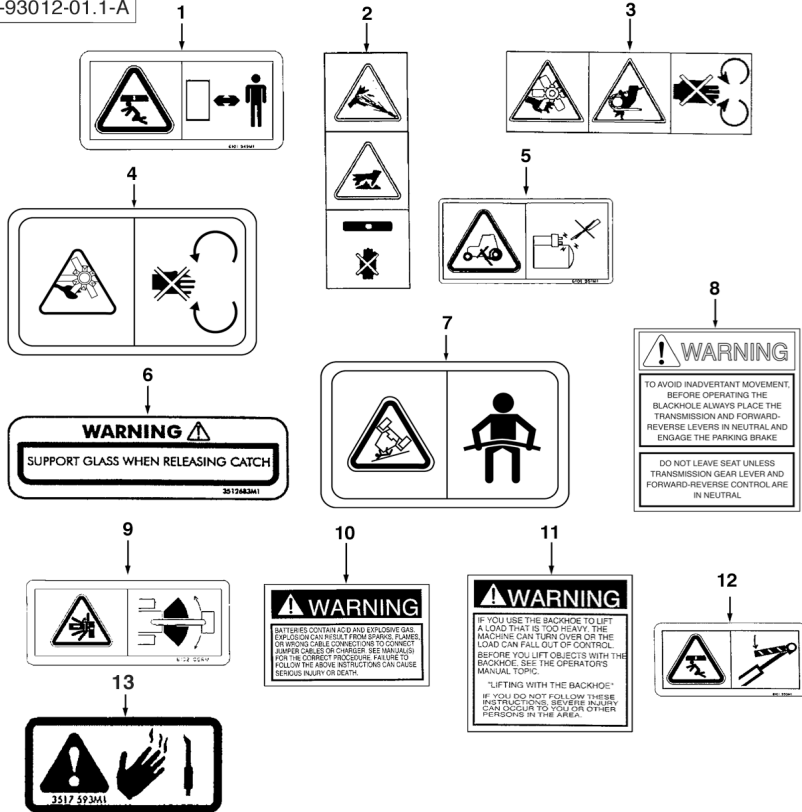

1	6101949M1	Keep Away	4	Decal	Adhésif	Adhesivo
2	6010161M2	Radiator	1	Decal	Adhésif	Adhesivo
3	6010160M2	Fan	2	Decal	Adhésif	Adhesivo
4	6010164M1	Engine Cover	2	Decal	Adhésif	Adhesivo
5	6101951M2	Bypass Start	1	Decal	Adhésif	Adhesivo
6	3512683M1	Support Glass	1	Decal	Adhésif	Adhesivo
7	6101952M2	ROPS Seat Belt	1	Decal	Adhésif	Adhesivo
8	6102184M1	Engage Neutral	1	Decal	Adhésif	Adhesivo
9	6102056M1	Avoid Crushing	2	Decal	Adhésif	Adhesivo
10	321-6714	Battery	1	Decal	Adhésif	Adhesivo
11	321-6046	Boom	1	Decal	Adhésif	Adhesivo
12	6101950M2	Safety Strut	1	Decal	Adhésif	Adhesivo
13	3517593M1	Exhaust	2	Decal	Adhésif	Adhesivo



820 860 880 970 980
TX760B TX860B

805 807 817 825 845 855 921 931

93012C01.1

6199042M3

1

Jan-06

Decals
Adhésifs
Adhesivos

Warnings
Avertissements
Avisos

C-93013-01.1-A

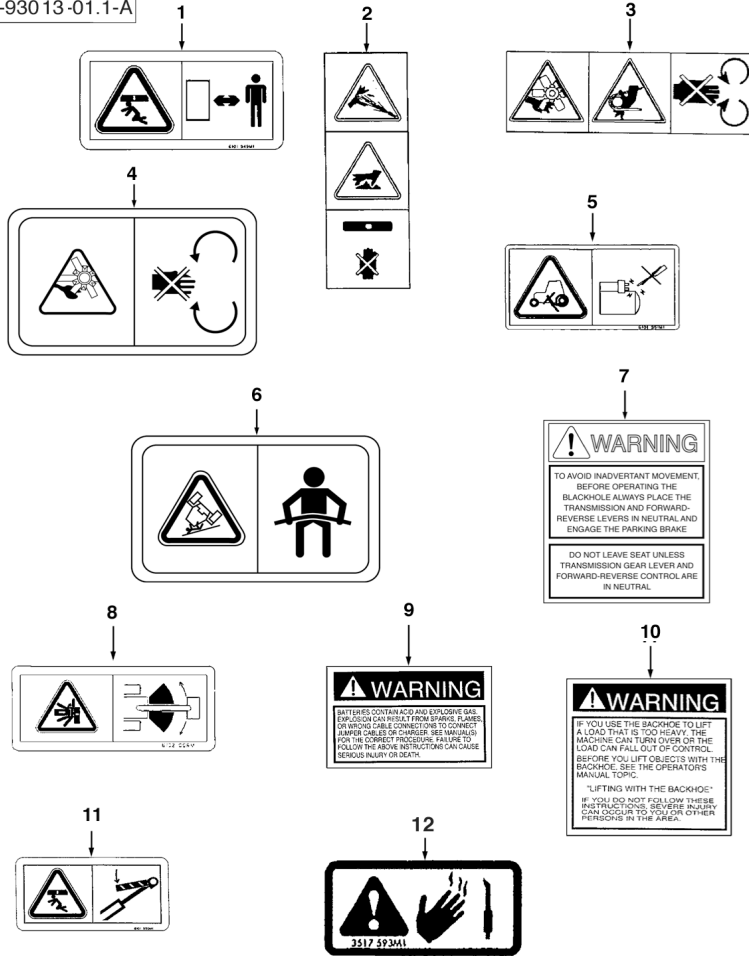

1	6101949M1	Keep Away	4	Decal	Adhésif	Adhesivo
2	6010161M2	Radiator	1	Decal	Adhésif	Adhesivo
3	6010160M2	Fan	2	Decal	Adhésif	Adhesivo
4	6010164M1	Engine Cover	2	Decal	Adhésif	Adhesivo
5	6101951M2	Bypass Start	1	Decal	Adhésif	Adhesivo
6	6101952M2	ROPS Seat Belt	1	Decal	Adhésif	Adhesivo
7	6102184M1	Engage Neutral	1	Decal	Adhésif	Adhesivo
8	6102056M1	Avoid Crushing	2	Decal	Adhésif	Adhesivo
9	321-6714	Battery	1	Decal	Adhésif	Adhesivo
10	321-6046	Boom	1	Decal	Adhésif	Adhesivo
11	6101950M2	Safety Strut	1	Decal	Adhésif	Adhesivo
12	3517593M1	Exhaust	2	Decal	Adhésif	Adhesivo



820 860 880
TX760B TX860B
TX870B

802 804 806 808 810 812 814 816 822 824 832 834 842 844 852 854

93013C01.1

6199042M3

1

Jan-06

Decals
Adhésifs
Adhesivos

Warnings
Avertissements
Avisos

C-93014-01.1-A

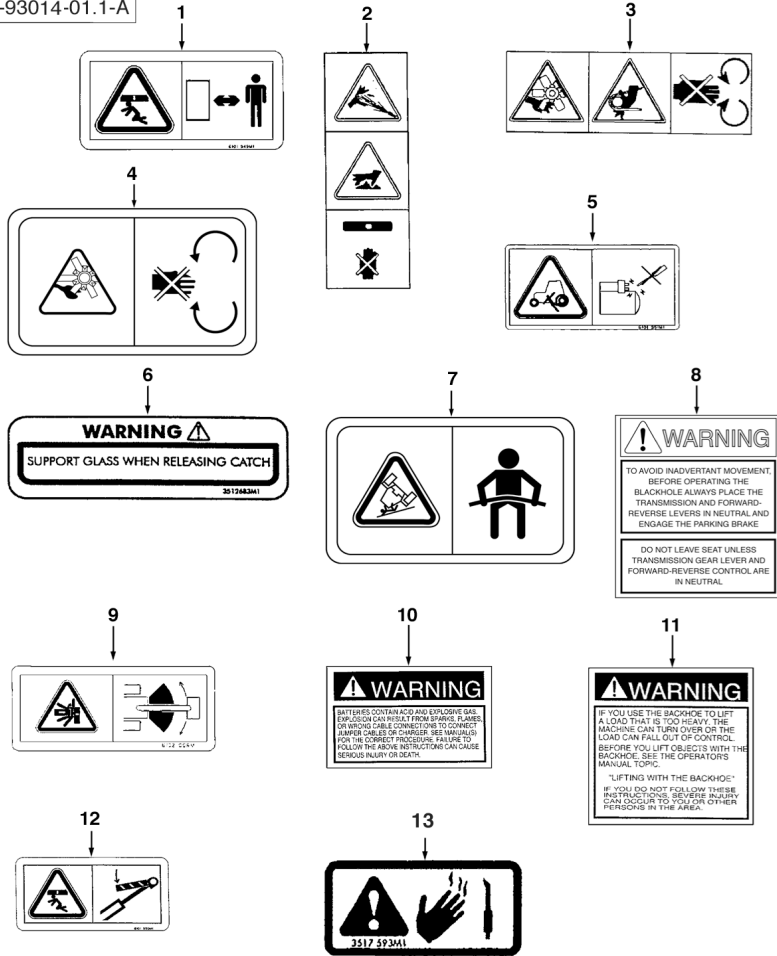

1	6101949M1	Keep Away	4	Decal	Adhésif	Adhesivo
2	6010161M2	Radiator	1	Decal	Adhésif	Adhesivo
3	6010160M2	Fan	2	Decal	Adhésif	Adhesivo
4	6010164M1	Engine Cover	2	Decal	Adhésif	Adhesivo
5	6101951M2	Bypass Start	1	Decal	Adhésif	Adhesivo
6	3512683M1	Support Glass	1	Decal	Adhésif	Adhesivo
7	6101952M2	ROPS Seat Belt	1	Decal	Adhésif	Adhesivo
8	6102184M1	Engage Neutral	1	Decal	Adhésif	Adhesivo
9	6102056M1	Avoid Crushing	2	Decal	Adhésif	Adhesivo
10	321-6714	Battery	1	Decal	Adhésif	Adhesivo
11	321-6046	Boom	1	Decal	Adhésif	Adhesivo
12	6101950M2	Safety Strut	1	Decal	Adhésif	Adhesivo
13	3517593M1	Exhaust	2	Decal	Adhésif	Adhesivo



820 860 880
TX760B TX860B
TX870B

801 803 805 807 809 811 813 815 821 823 825 831 833 841 843 851 853 855

**Decals
Adhésifs
Adhesivos**

**Warnings
Avertissements
Avisos**

C-93015-01.1-A

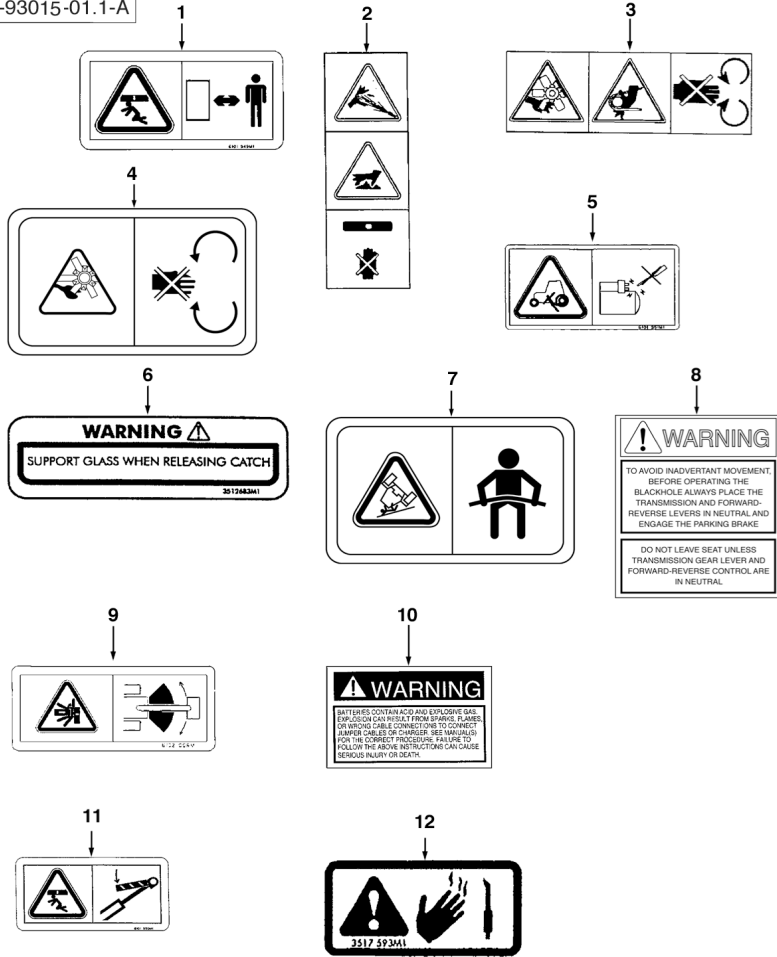

1	6101949M1	Keep Away	4	Decal	Adhésif	Adhesivo
2	6010161M2	Radiator	1	Decal	Adhésif	Adhesivo
3	6010160M2	Fan	2	Decal	Adhésif	Adhesivo
4	6010164M1	Engine Cover	2	Decal	Adhésif	Adhesivo
5	6101951M2	Bypass Start	1	Decal	Adhésif	Adhesivo
6	3512683M1	Support Glass	1	Decal	Adhésif	Adhesivo
7	6101952M2	ROPS Seat Belt	1	Decal	Adhésif	Adhesivo
8	6102184M1	Engage Neutral	1	Decal	Adhésif	Adhesivo
9	6102056M1	Avoid Crushing	2	Decal	Adhésif	Adhesivo
10	321-6714	Battery	1	Decal	Adhésif	Adhesivo
11	6101950M2	Safety Strut	1	Decal	Adhésif	Adhesivo
12	3517593M1	Exhaust	2	Decal	Adhésif	Adhesivo



801 803 805 807 813 815 817 821 823 825 841 843 845 851 853 855

**Decals
Adhésifs
Adhesivos**

**Warnings
Avertissements
Avisos**

C-93016-01.1-A

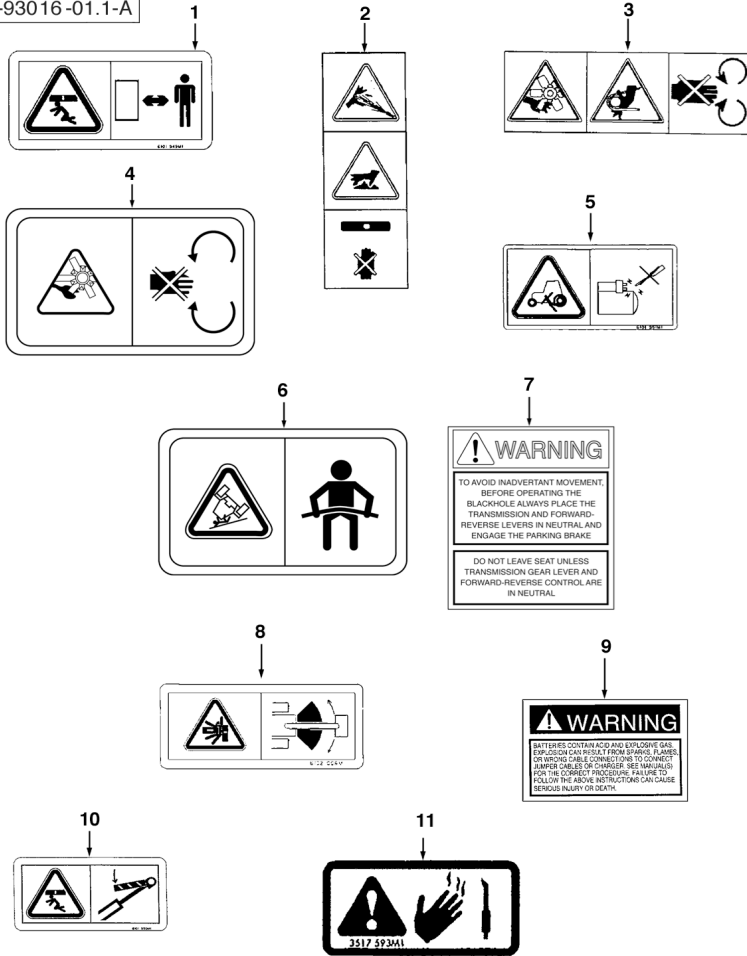

1	6101949M1	Keep Away	4	Decal	Adhésif	Adhesivo
2	6010161M2	Radiator	1	Decal	Adhésif	Adhesivo
3	6010160M2	Fan	2	Decal	Adhésif	Adhesivo
4	6010164M1	Engine Cover	2	Decal	Adhésif	Adhesivo
5	6101951M2	Bypass Start	1	Decal	Adhésif	Adhesivo
6	6101952M2	ROPS Seat Belt	1	Decal	Adhésif	Adhesivo
7	6102184M1	Engage Neutral	1	Decal	Adhésif	Adhesivo
8	6102056M1	Avoid Crushing	2	Decal	Adhésif	Adhesivo
9	321-6714	Battery	1	Decal	Adhésif	Adhesivo
10	6101950M2	Safety Strut	1	Decal	Adhésif	Adhesivo
11	3517593M1	Exhaust	2	Decal	Adhésif	Adhesivo



820 860 880
TX760B TX860B
TX870B

802 804 806 808 814 816 822 824 842 844 852 854

**Decals
Adhésifs
Adhesivos**

**Warnings
Avertissements
Avisos**

C-93017-01.1-A

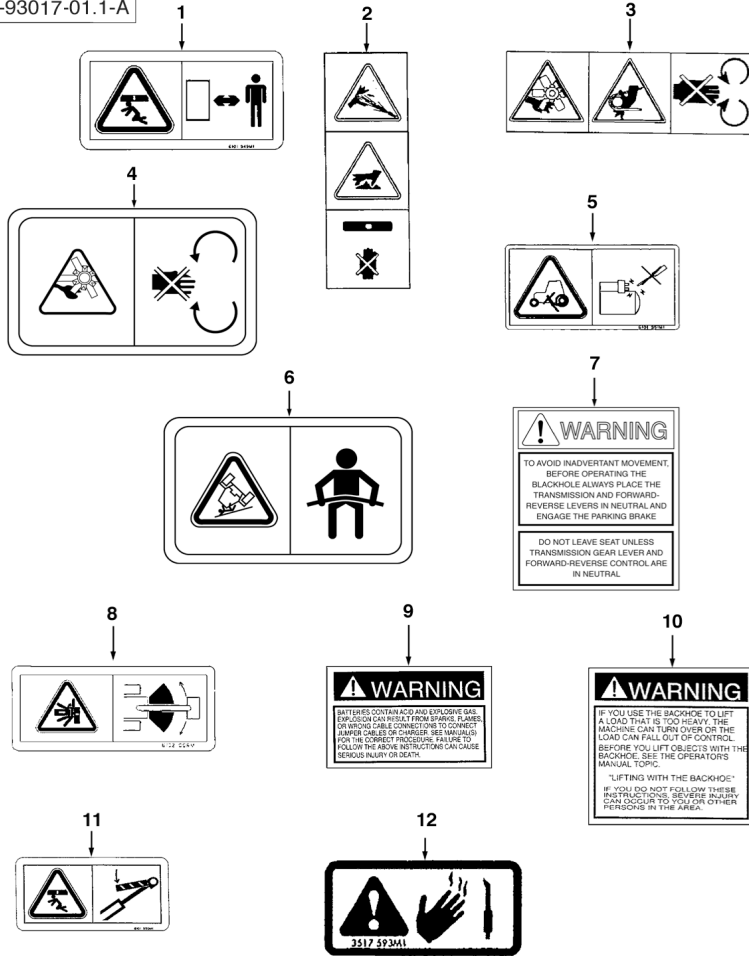

1	6101949M1	Keep Away	4	Decal	Adhésif	Adhesivo
2	6010161M2	Radiator	1	Decal	Adhésif	Adhesivo
3	6010160M2	Fan	2	Decal	Adhésif	Adhesivo
4	6010164M1	Engine Cover	2	Decal	Adhésif	Adhesivo
5	6101951M2	Bypass Start	1	Decal	Adhésif	Adhesivo
6	6101952M2	ROPS Seat Belt	1	Decal	Adhésif	Adhesivo
7	6102184M1	Engage Neutral	1	Decal	Adhésif	Adhesivo
8	6102056M1	Avoid Crushing	2	Decal	Adhésif	Adhesivo
9	321-6714	Battery	1	Decal	Adhésif	Adhesivo
10	321-6046	Boom	1	Decal	Adhésif	Adhesivo
11	6101950M2	Safety Strut	1	Decal	Adhésif	Adhesivo
12	3517593M1	Exhaust	2	Decal	Adhésif	Adhesivo



820 860 880
TX760B TX860B
TX870B

802 804 806 808 814 816 822 824 842 844 852 854

93017C01.1

6199042M3

1

Jan-06

**Decals
Adhésifs
Adhesivos**

**Warnings
Avertissements
Avisos**

C-93018-01.1-A

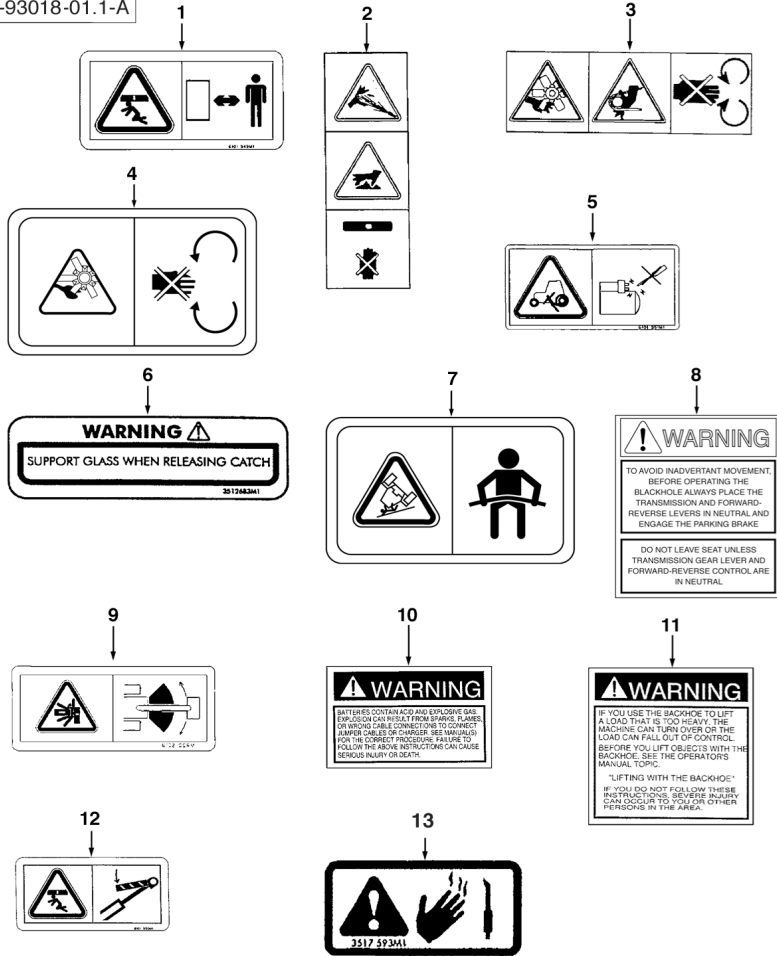

1	6101949M1	Keep Away	4	Decal	Adhésif	Adhesivo
2	6010161M2	Radiator	1	Decal	Adhésif	Adhesivo
3	6010160M2	Fan	2	Decal	Adhésif	Adhesivo
4	6010164M1	Engine Cover	2	Decal	Adhésif	Adhesivo
5	6101951M2	Bypass Start	1	Decal	Adhésif	Adhesivo
6	3512683M1	Support Glass	1	Decal	Adhésif	Adhesivo
7	6101952M2	ROPS Seat Belt	1	Decal	Adhésif	Adhesivo
8	6102184M1	Engage Neutral	1	Decal	Adhésif	Adhesivo
9	6102056M1	Avoid Crushing	2	Decal	Adhésif	Adhesivo
10	321-6714	Battery	1	Decal	Adhésif	Adhesivo
11	321-6046	Boom	1	Decal	Adhésif	Adhesivo
12	6101950M2	Safety Strut	1	Decal	Adhésif	Adhesivo
13	3517593M1	Exhaust	2	Decal	Adhésif	Adhesivo



820 860 880
TX760B TX860B
TX870B

801 803 805 807 813 815 821 823 825 841 843 845 851 853 855

**Decals
Adhésifs
Adhesivos**

**Warnings
Avertissements
Avisos**

C-93020-01.1-A

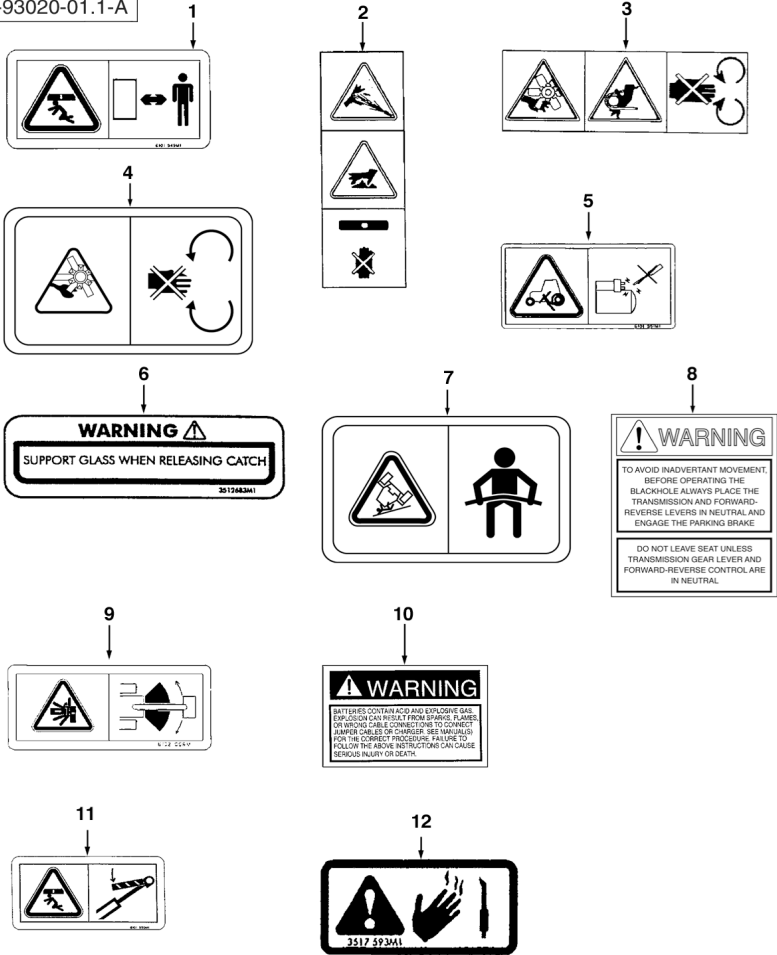

1	6101949M1	Keep Away	4	Decal	Adhésif	Adhesivo
2	6010161M2	Radiator	1	Decal	Adhésif	Adhesivo
3	6010160M2	Fan	2	Decal	Adhésif	Adhesivo
4	6010164M1	Engine Cover	2	Decal	Adhésif	Adhesivo
5	6101951M2	Bypass Start	1	Decal	Adhésif	Adhesivo
6	3512687M1	Support Glass	1	Decal	Adhésif	Adhesivo
7	6101952M2	ROPS Seat Belt	1	Decal	Adhésif	Adhesivo
8	6102190M1	Engage Neutral	1	Decal	Adhésif	Adhesivo
9	6102056M1	Avoid Crushing	2	Decal	Adhésif	Adhesivo
10	321-6750	Battery	1	Decal	Adhésif	Adhesivo
11	6101950M2	Safety Strut	1	Decal	Adhésif	Adhesivo
12	3517593M1	Exhaust	2	Decal	Adhésif	Adhesivo



820 860 880 970 980
TX760B TX860B

805 807 817 825 845 855 921 931

**Decals
Adhésifs
Adhesivos**

**Warnings
Avertissements
Avisos**

C-93021-01.1-A

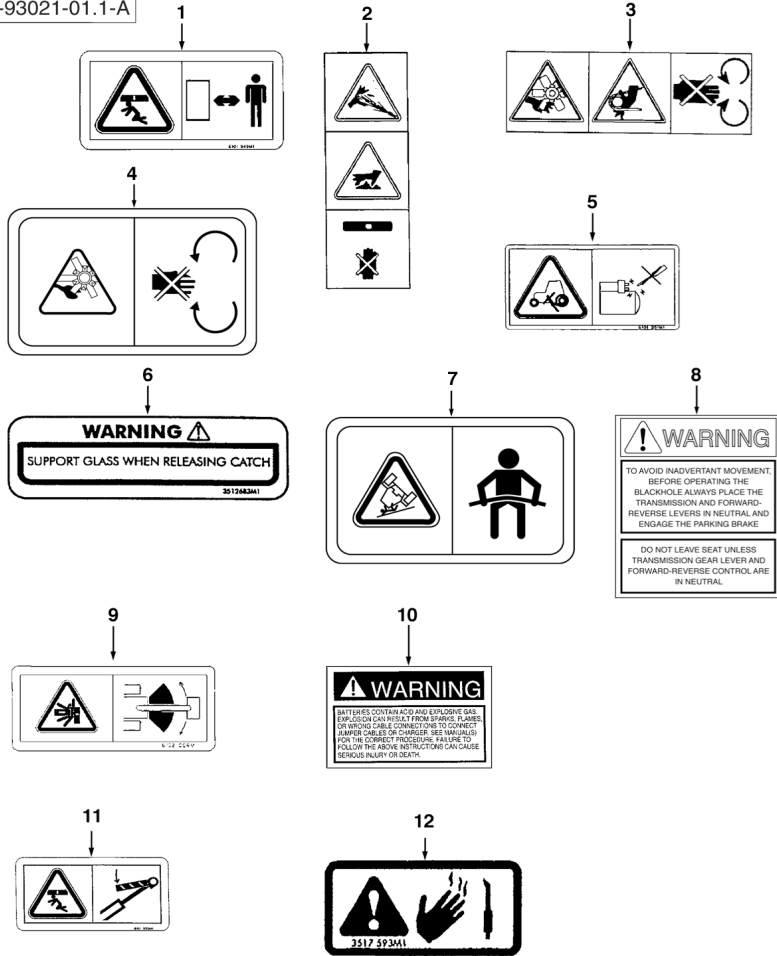

1	6101949M1	Keep Away	4	Decal	Adhésif	Adhesivo
2	6010161M2	Radiator	1	Decal	Adhésif	Adhesivo
3	6010160M2	Fan	2	Decal	Adhésif	Adhesivo
4	6010164M1	Engine Cover	2	Decal	Adhésif	Adhesivo
5	6101951M2	Bypass Start	1	Decal	Adhésif	Adhesivo
6	3512683M1	Support Glass	1	Decal	Adhésif	Adhesivo
7	6101952M2	ROPS Seat Belt	1	Decal	Adhésif	Adhesivo
8	6102184M1	Engage Neutral	1	Decal	Adhésif	Adhesivo
9	6102056M1	Avoid Crushing	2	Decal	Adhésif	Adhesivo
10	321-6714	Battery	1	Decal	Adhésif	Adhesivo
11	6101950M2	Safety Strut	1	Decal	Adhésif	Adhesivo
12	3517593M1	Exhaust	2	Decal	Adhésif	Adhesivo



820 860 880 970 980
TX760B TX860B
TX870B TX970B

801 803 805 807 813 815 817 821 823 825 841 843 845 851 853 855 921 922 923
931 932

**Decals
Adhésifs
Adhesivos**

**Warnings
Avertissements
Avisos**

C-93022-01.1-A

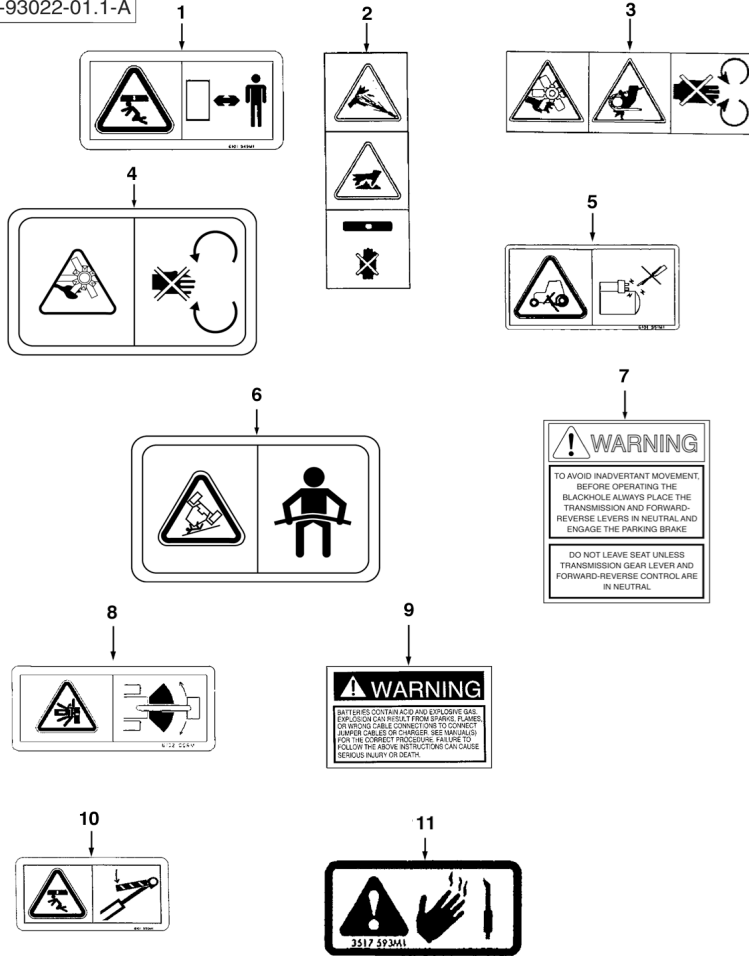

1	6101949M1	Keep Away	4	Decal	Adhésif	Adhesivo
2	6010161M2	Radiator	1	Decal	Adhésif	Adhesivo
3	6010160M2	Fan	2	Decal	Adhésif	Adhesivo
4	6010164M1	Engine Cover	2	Decal	Adhésif	Adhesivo
5	6101951M2	Bypass Start	1	Decal	Adhésif	Adhesivo
6	6101952M2	ROPS Seat Belt	1	Decal	Adhésif	Adhesivo
7	6102184M1	Engage Neutral	1	Decal	Adhésif	Adhesivo
8	6102056M1	Avoid Crushing	2	Decal	Adhésif	Adhesivo
9	321-6714	Battery	1	Decal	Adhésif	Adhesivo
10	6101950M2	Safety Strut	1	Decal	Adhésif	Adhesivo
11	3517593M1	Exhaust	2	Decal	Adhésif	Adhesivo



820 860 880
TX760B TX860B
TX870B

802 804 806 808 814 816 822 824 842 844 852 854

93022C01.1

6199042M3

1

Jan-06

Decals
Adhésifs
Adhesivos

Warnings
Avertissements
Avisos

C-93023-01.1-A

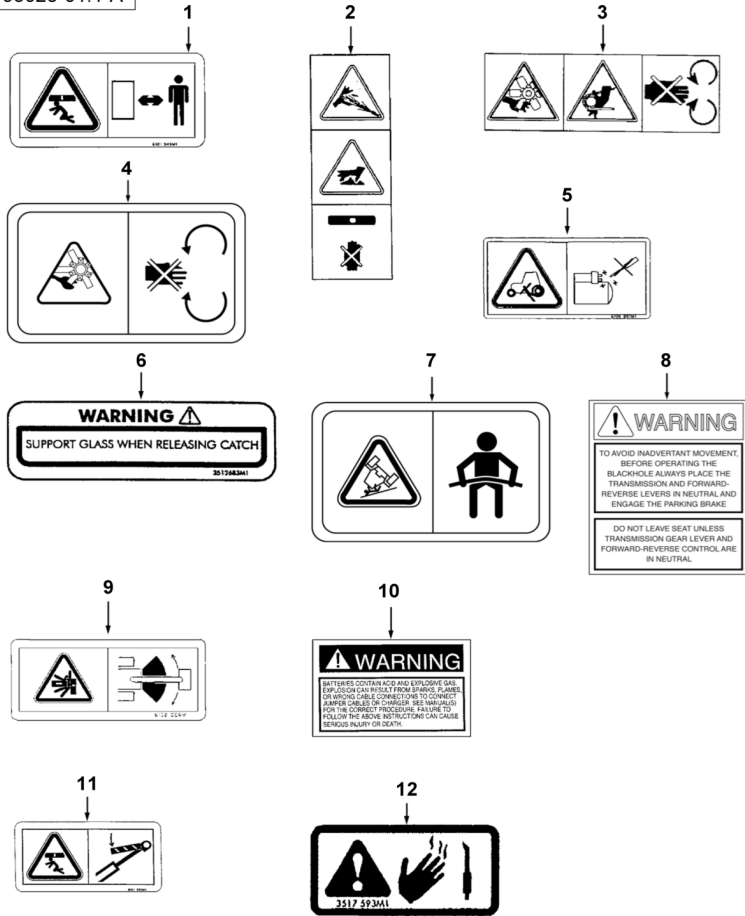

1	6101949M1	Keep Away	4	Decal	Adhésif	Adhesivo
2	6010161M2	Radiator	1	Decal	Adhésif	Adhesivo
3	6010160M2	Fan	2	Decal	Adhésif	Adhesivo
4	6010164M1	Engine Cover	2	Decal	Adhésif	Adhesivo
5	6101951M2	Bypass Start	1	Decal	Adhésif	Adhesivo
6	3512686M1	Support Glass	1	Decal	Adhésif	Adhesivo
7	6101952M2	ROPS Seat Belt	1	Decal	Adhésif	Adhesivo
8	6102185M1	Engage Neutral	1	Decal	Adhésif	Adhesivo
9	6102056M1	Avoid Crushing	2	Decal	Adhésif	Adhesivo
10	321-6719	Battery	1	Decal	Adhésif	Adhesivo
11	6101950M2	Safety Strut	1	Decal	Adhésif	Adhesivo
12	3517593M1	Exhaust	2	Decal	Adhésif	Adhesivo



880 980
TX860B

845 855 931

Digger Stabilisers
Stabilisateurs
Estabilizadores

Safety Kit
Coffret de Sécurité
Juego de seguridad

C-95015-01.1-A

1	6108635M91		1	Support Assy	Ensemble de support	Apoyadero, Conj.
---	------------	--	---	--------------	---------------------	------------------

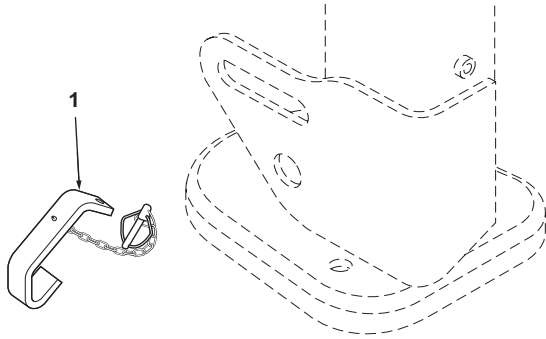

820 860 880 970 980
TX760B TX860B

805 807 817 825 845 855 921 931

Headlamp Extension
Extension de Phare
Extensión para el faro delantero

C-95014-01.1-A

1	6102818M92	◀	1	Bracket Assy	Ensemble chaise palier	Cuchara, Conj.
1	6102817M92	▶	1	Bracket Assy	Ensemble chaise palier	Cuchara, Conj.
2	6102863M2		2	Cover	Cache	Tapa
3	391244X1	M6 x 45	2	Bolt	Boulon	Perno
4	1441500X1	M6	2	Nut, Lock	Écrou de blocage	Tuerca de retención
5	3009492X1	M10 x 25	2	Screw	Vis	Tornillo
6	1440329X1	M10	2	Nut, Lock	Écrou de blocage	Tuerca de retención
7	6108516M91		2	Harness Assy	Ensemble de faisceau	Haz, Conj.

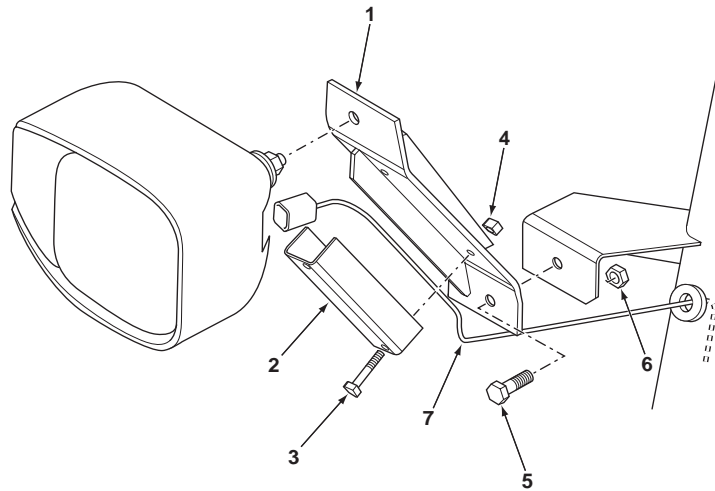

820 860 880 970 980
 TX760B TX860B

805 807 817 825 845 855 921 931

95014C01.1

6199042M3

1

Jan-06

Licence Plate
Plaque Minéralogique
Placa de matrícula

Front
Avant
Delantero

C-95010-01.1-A

1	6106159M91	ⓓ	1	Holder No Plate	Plaque d'identification	Portador n° de placa
2	3009537X1	M5 x 20	2	Screw	Vis	Tornillo
3	3019560X1		2	Washer	Rondelle	Arandela

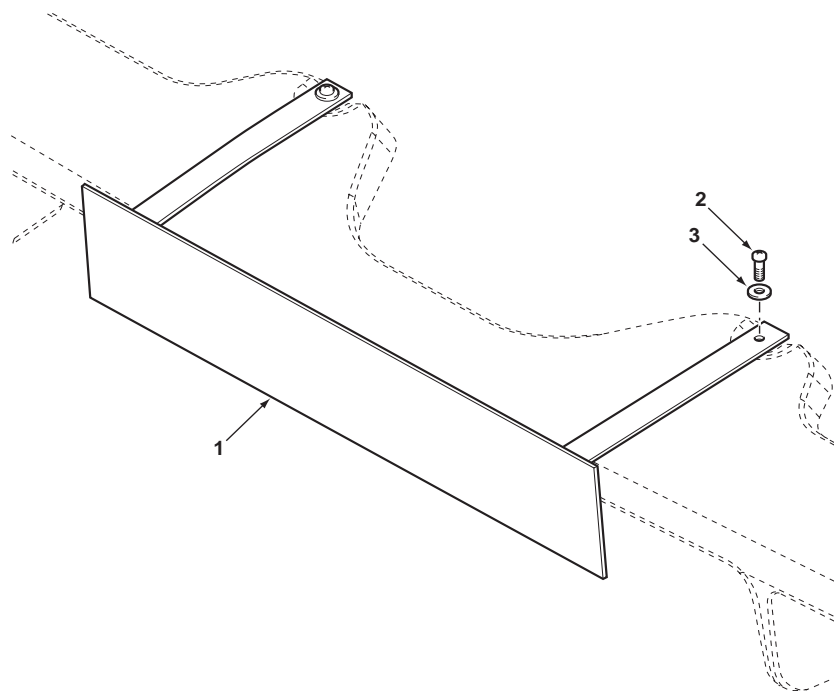

820 860 880 970 980
TX760B TX860B

805 807 817 825 845 855 921 931

95010C01.1

6199042M3

1

Jan-06

Licence Plate
 Plaque Minéralogique
 Placa de matrícula

Rear
 Arrière
 Trasero

C-95011-01.1-A

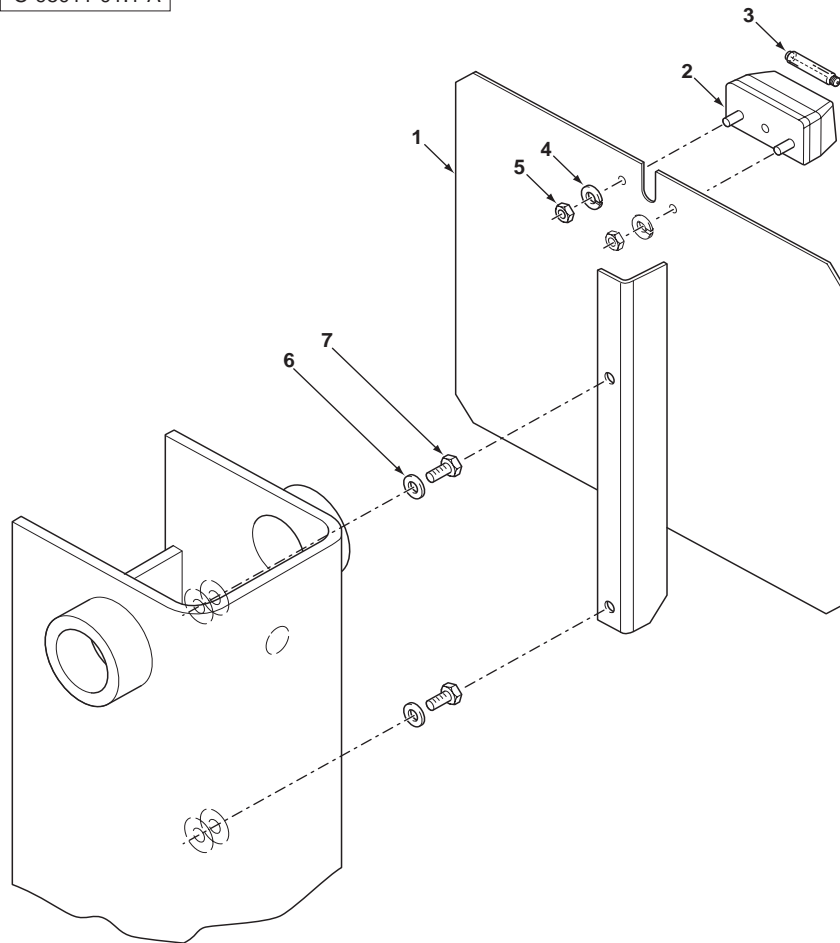

1	6106999M91			1	Plate, Licence	Plaque immatricul.	Placa de matrícula
2	3516826M91			1	Lamp Assy	Ensemble de feux	Luz, Conj.
3	3523686M1	2	12V - 5W	1	Bulb	Lampe	Lámpara
4	339381X1	2	M5	2	Washer, Lock	Rondelle de blocage	Arandela de freno
5	390995X1	2	M5	2	Nut	Écrou	Tuerca
6	339374X1		M8	2	Washer, Lock	Rondelle de blocage	Arandela de freno
7	339228X1		M8 x 12	2	Screw	Vis	Tornillo



820 860 880 970 980
 TX760B TX860B

805 806 807 808 817 825 833 834 845 855 921 931

95011C01.1

6199042M3

1

Jan-06

Literature
Documentation
Documentación

English
Anglais
Inglés

C-96011-01.1-A

1	6110221M2	English	1	Book, Instruction	Manuel d'installation	Folleto
2	6109249M1	Noise 104 db	1	Decal	Adhésif	Adhesivo

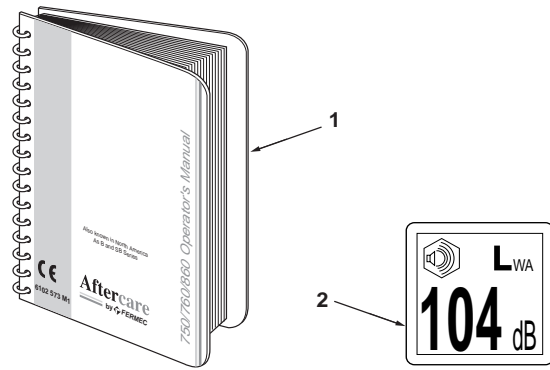

820
TX760B

801 802 803 804 805 806 807 808

96011C01.1

6199042M3

1

Jan-06

Literature
Documentation
Documentación

French
Français
Francés

C-96012-01.1-A

1	6110222M2	French	1	Book, Instruction	Manuel d'installation	Folleto
2	6109249M1	Noise 104 db	1	Decal	Adhésif	Adhesivo

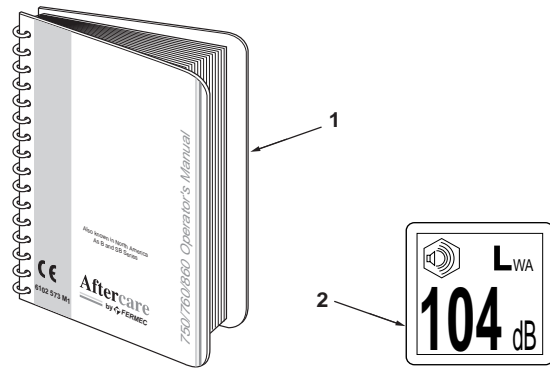

820
TX760B

805 807

96012C01.1

6199042M3

1

Jan-06

Literature
 Documentation
 Documentación

German
 Allemand
 Alemán

C-96013-01.1-A

1	6110223M2	German	1	Book, Instruction	Manuel d'installation	Folleto
2	6109249M1	Noise 104 db	1	Decal	Adhésif	Adhesivo
3	6108554M1	Parts Guide	1	Booklet	Livret	Folleto

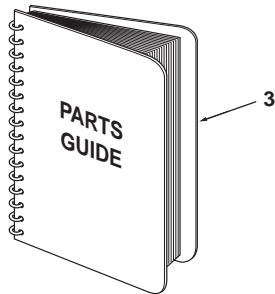
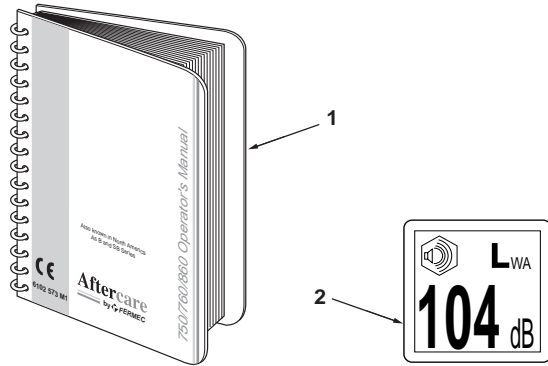

820
 TX760B

805 807

Literature
Documentation
Documentación

Italian
Italien
Italiano

C-96014-01.1-A

1	6110224M2	Italian	1	Book, Instruction	Manuel d'installation	Folleto
2	6109249M1	Noise 104 db	1	Decal	Adhésif	Adhesivo
3	6108554M1	Parts Guide	1	Booklet	Livret	Folleto

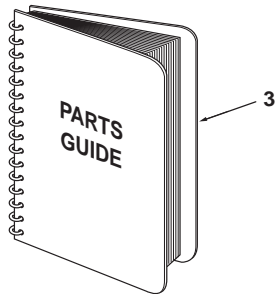
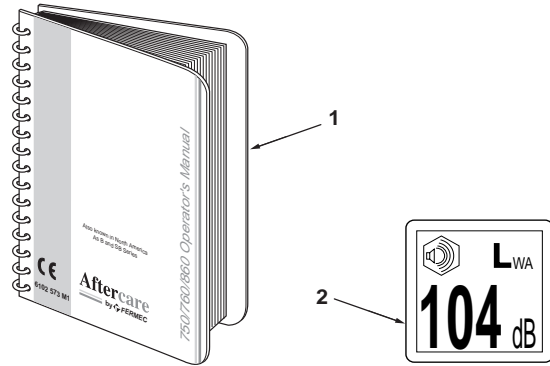

820
TX760B

805 807

96014C01.1

6199042M3

1

Jan-06

Literature
Documentation
Documentación

Spanish
Español
Español

C-96015-01.1-A

1	6110225M2	Spanish	1	Book, Instruction	Manuel d'installation	Folleto
2	6109249M1	Noise 104 db	1	Decal	Adhésif	Adhesivo

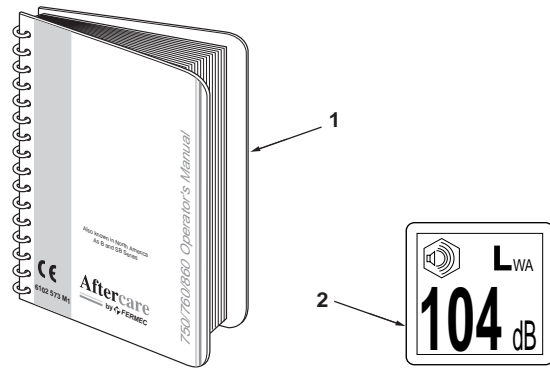

820 880 970 980
TX760B TX860B

801 802 803 804 805 806 807 808 855 921 931

Literature
Documentation
Documentación

Portuguese
Portugais
Portugués

C-96016-01.1-A

1	6110226M2	Portuguese	1	Book, Instruction	Manuel d'installation	Folleto
2	6109249M1	Noise 104 db	1	Decal	Adhésif	Adhesivo

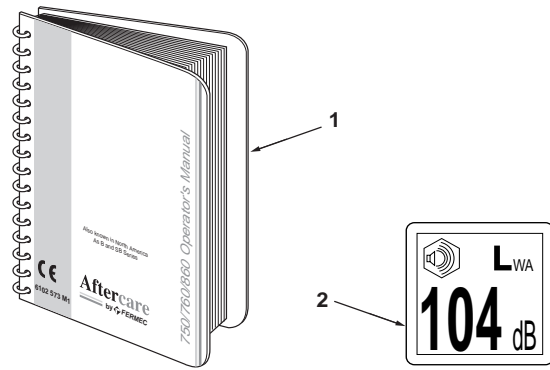

820 880 970 980
TX760B TX860B

805 807 855 921 931

96016C01.1

6199042M3

1

Jan-06

Literature
Documentation
Documentación

Danish
Danois
Danés

C-96017-01.1-A

1	6110227M2	Danish	1	Book, Instruction	Manuel d'installation	Folleto
2	6109249M1	Noise 104 db	1	Decal	Adhésif	Adhesivo

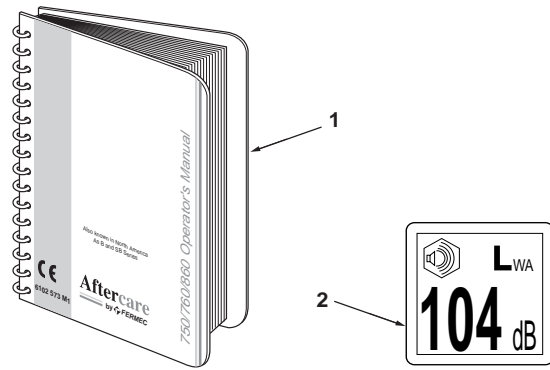

820 880 970 980
TX760B TX860B

805 807 855 921 931

96017C01.1

6199042M3

1

Jan-06

Literature
Documentation
Documentación

Dutch
Néerlandais
Holandés

C-96018-01.1-A

1	6110228M2	Dutch	1	Book, Instruction	Manuel d'installation	Folleto
2	6109249M1	Noise 104 db	1	Decal	Adhésif	Adhesivo

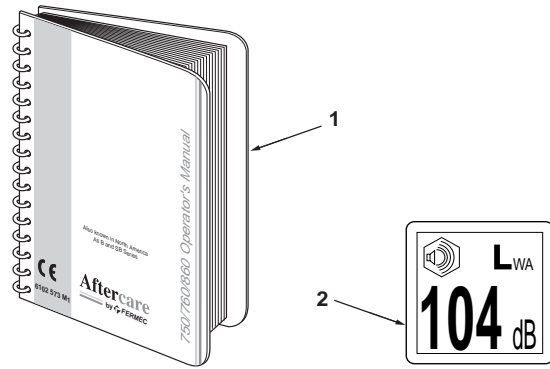

820 880 970 980
TX760B TX860B

805 807 855 921 931

96018C01.1

6199042M3

1

Jan-06

Literature
Documentation
Documentación

Finnish
Finlandais
Finlandés

C-96019-01.1-A

1	6110229M2	Finnish	1	Book, Instruction	Manuel d'installation	Folleto
2	6109249M1	Noise 104 db	1	Decal	Adhésif	Adhesivo

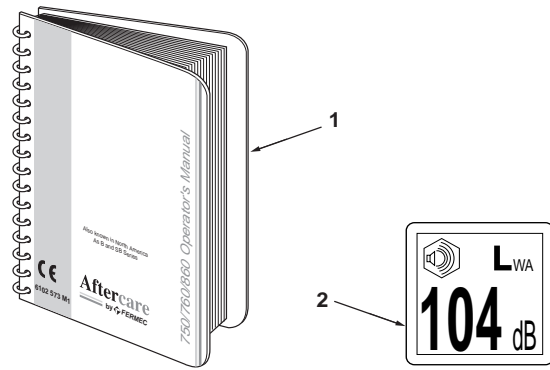

820
TX760B

801 803 805 807

96019C01.1

6199042M3

1

Jan-06

Literature
Documentation
Documentación

Spanish
Español
Español

C-96020-01.1-A

1	6110225M2	Spanish	1	Book, Instruction	Manuel d'installation	Folleto
2	6109250M1	Noise 105 db	1	Decal	Adhésif	Adhesivo

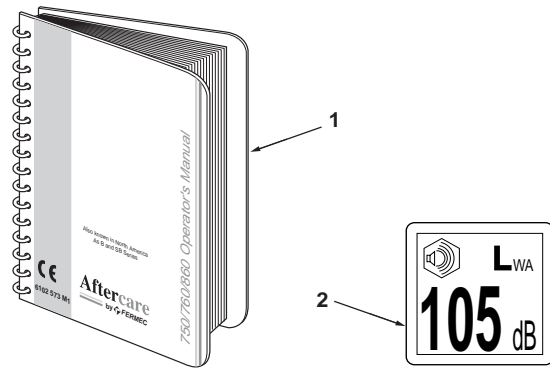

860 880 970 980
TX860B TX870B
TX970B

813 814 815 816 817 821 822 823 824 825 841 842 843 844 845 851 852 853 854
855 921 922 923 931 932

Literature
Documentation
Documentación

Finnish
Finlandais
Finlandés

C-96021-01.1-A

1	6110229M2	Finnish	1	Book, Instruction	Manuel d'installation	Folleto
2	6109250M1	Noise 105 db	1	Decal	Adhésif	Adhesivo

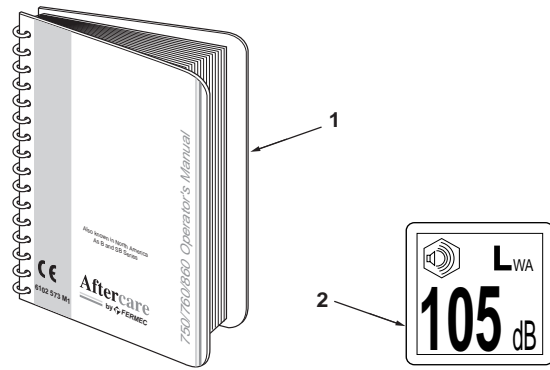

860 880 970 980
TX860B TX870B
TX970B

813 815 817 821 823 825 841 843 845 851 853 855 921 922 923 931 932

96021C01.1

6199042M3

1

Jan-06

Literature
Documentation
Documentación

North America
Amérique du Nord
América del norte

C-96022-01.1-B

1	6110221M2	English	1	Book, Instruction	Manuel d'installation	Folleto
---	-----------	---------	---	-------------------	-----------------------	---------

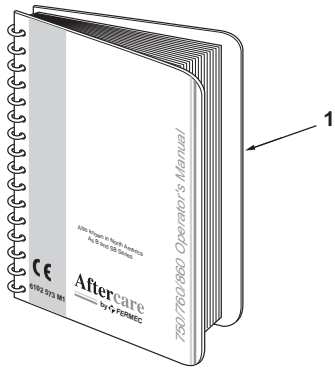

820 860 880
TX760B TX860B
TX870B

801 802 803 804 805 806 807 808 809 810 811 812 813 814 815 816 821 822 823
824 825 831 832 833 834 841 842 843 844

96022C01.1

6199042M3

1

Jan-06

Literature
Documentation
Documentación

English
Anglais
Inglés

C-96023-01.1-A

1	6110221M1	English	1	Book, Instruction	Manuel d'installation	Folleto
2	6109249M1	Noise 104 db	1	Decal	Adhésif	Adhesivo

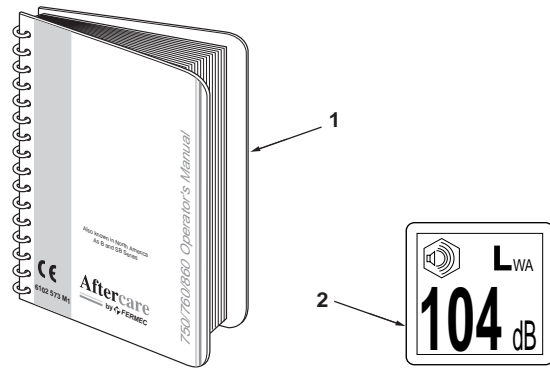

820
TX760B

801 802 803 804 805 806 807 808

96023C01.1

6199042M3

1

Jan-06

Literature
 Documentation
 Documentación

Italian
 Italien
 Italiano

C-96026-01.1-A

1	6110224M1	Italian	1	Book, Instruction	Manuel d'installation	Folleto
2	6109249M1	Noise 104 db	1	Decal	Adhésif	Adhesivo
3	6108554M1	Parts Guide	1	Booklet	Livret	Folleto

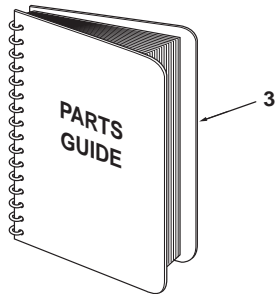
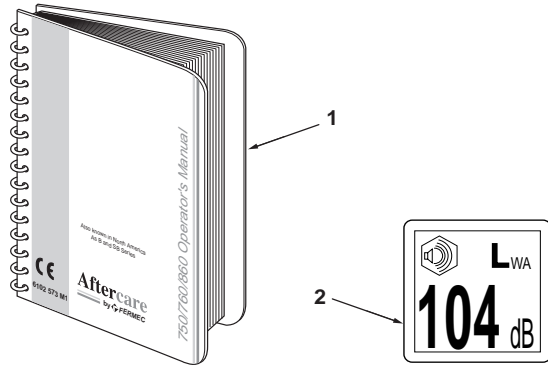

820
 TX760B

805 807

Literature
Documentation
Documentación

Portuguese
Portugais
Portugués

C-96028-01.1-A

1	6110226M1	Portuguese	1	Book, Instruction	Manuel d'installation	Folleto
2	6109249M1	Noise 104 db	1	Decal	Adhésif	Adhesivo

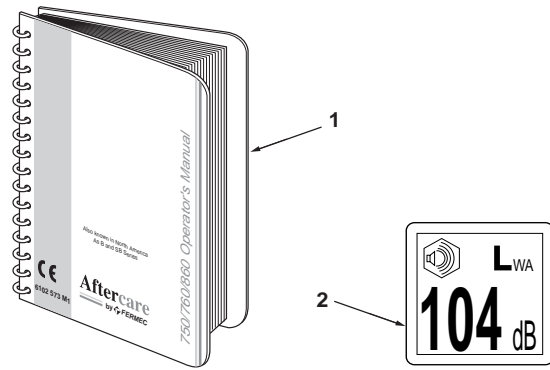

820
TX760B

805 807

96028C01.1

6199042M3

1

Jan-06

Literature
Documentation
Documentación

Danish
Danois
Danés

C-96029-01.1-A

1	6110227M1	Danish	1	Book, Instruction	Manuel d'installation	Folleto
2	6109249M1	Noise 104 db	1	Decal	Adhésif	Adhesivo

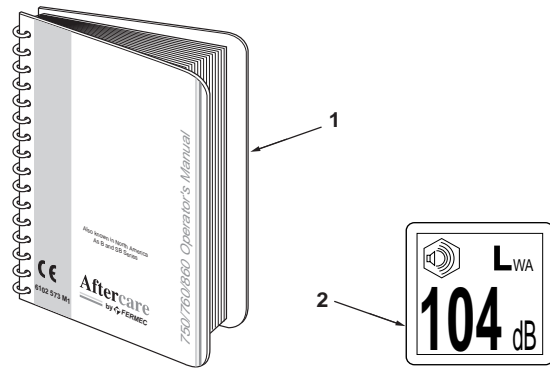

820
TX760B

805 807

96029C01.1

6199042M3

1

Jan-06

Literature
Documentation
Documentación

English
Anglais
Inglés

C-96041-01.1-A

1	6110221M2	English	1	Book, Instruction	Manuel d'installation	Folleto
2	6109250M1	Noise 105 db	1	Decal	Adhésif	Adhesivo

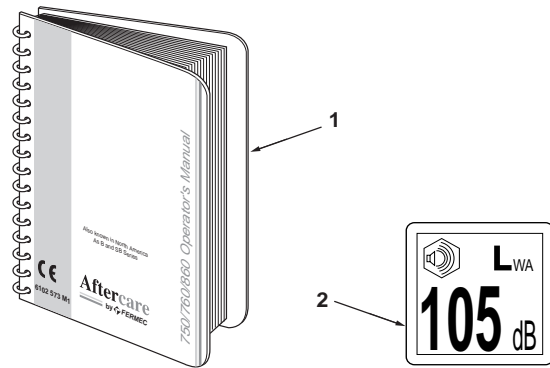

860 880 970 980
TX860B TX870B
TX970B

813 814 815 816 817 821 822 823 824 825 841 842 843 844 845 851 852 853 854
855 921 922 923 931 932

Literature
Documentation
Documentación

French
Français
Francés

C-96042-01.1-A

1	6110222M2	French	1	Book, Instruction	Manuel d'installation	Folleto
2	6109250M1	Noise 105 db	1	Decal	Adhésif	Adhesivo

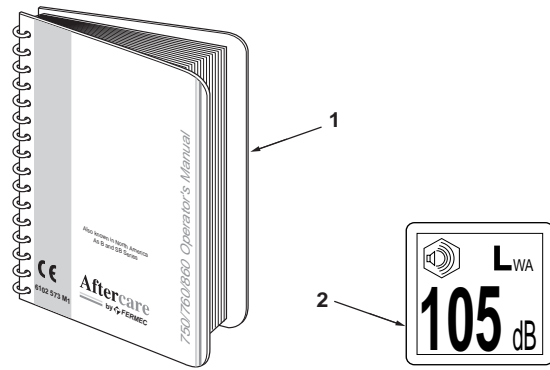

860 880 970 980
TX860B

817 825 845 855 921 931

96042C01.1

6199042M3

1

Jan-06

Literature
Documentation
Documentación

German
Allemand
Alemán

C-96043-01.1-A

1	6110223M2	German	1	Book, Instruction	Manuel d'installation	Folleto
2	6109250M1	Noise 105 db	1	Decal	Adhésif	Adhesivo
3	6108554M1	Parts Guide	1	Booklet	Livret	Folleto

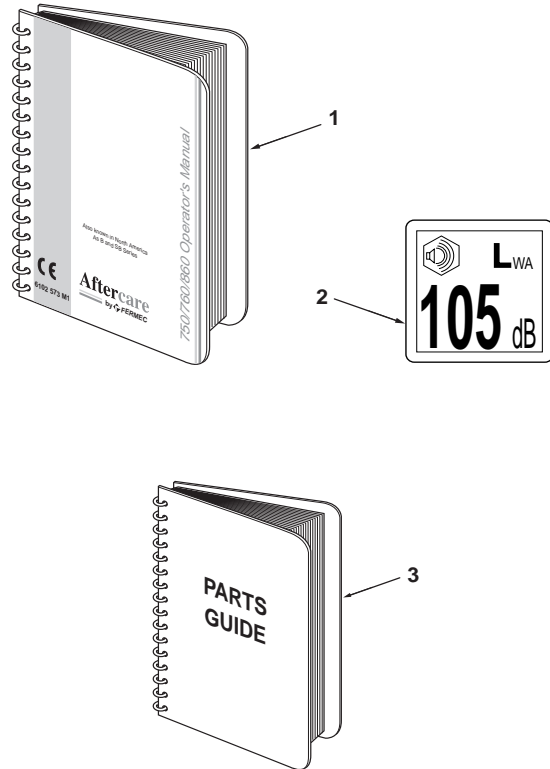

860 880 970 980
TX860B TX870B

817 825 843 845 855 921 931

96043C01.1

6199042M3

1

Jan-06

Literature
Documentation
Documentación

Italian
Italien
Italiano

C-96044-01.1-A

1	6110224M2	Italian	1	Book, Instruction	Manuel d'installation	Folleto
2	6109250M1	Noise 105 db	1	Decal	Adhésif	Adhesivo
3	6108554M1	Parts Guide	1	Booklet	Livret	Folleto

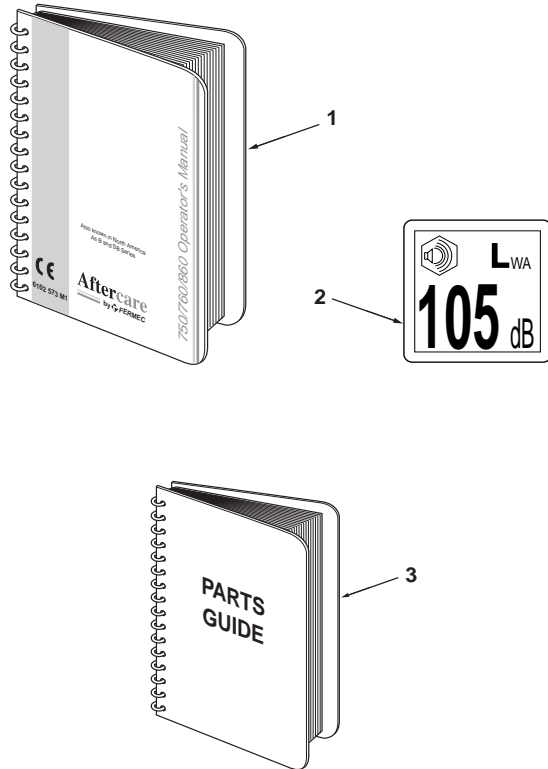

860 880 970 980
TX860B

817 825 845 855 921 931

96044C01.1

6199042M3

1

Jan-06

Literature
Documentation
Documentación

Portuguese
Portugais
Portugués

C-96045-01.1-A

1	6110226M2	Portuguese	1	Book, Instruction	Manuel d'installation	Folleto
2	6109250M1	Noise 105 db	1	Decal	Adhésif	Adhesivo

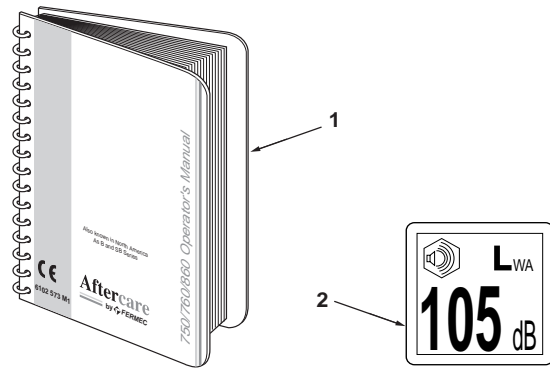

860 880 970 980
TX860B TX870B

817 825 841 842 843 844 845 851 853 855 921 931

96045C01.1

6199042M3

1

Jan-06

Literature
Documentation
Documentación

Danish
Danois
Danés

C-96046-01.1-A

1	6110227M2	Danish	1	Book, Instruction	Manuel d'installation	Folleto
2	6109250M1	Noise 105 db	1	Decal	Adhésif	Adhesivo

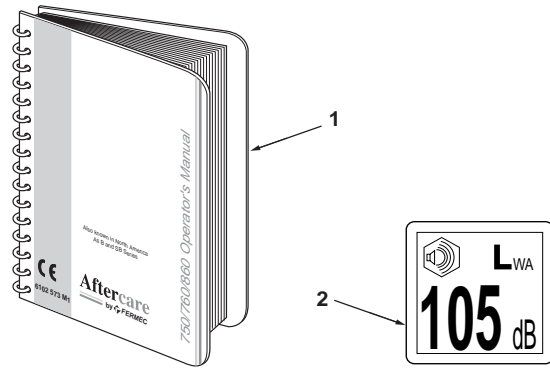

860 880 970 980
TX860B TX870B

817 825 843 845 855 921 931

96046C01.1

6199042M3

1

Jan-06

Literature
Documentation
Documentación

Dutch
Néerlandais
Holandés

C-96047-01.1-A

1	6110228M2	Dutch	1	Book, Instruction	Manuel d'installation	Folleto
2	6109250M1	Noise 105 db	1	Decal	Adhésif	Adhesivo

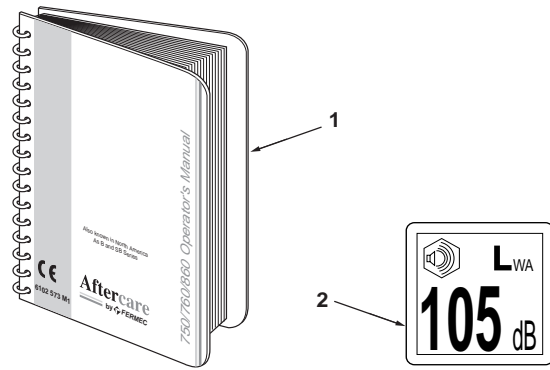

860 880 970 980
TX860B TX870B

817 825 843 845 855 921 931

96047C01.1

6199042M3

1

Jan-06

Position Indicator
Témoïn de Position
Indicador de posición

Loader Arm
Bras Chargeur
Brazo cargador

C-95013-01.1-A

1	6102484M2	ⓓ	1	Plate	Plaque	Placa
2	339337X1	M8 x 30	1	Bolt	Boulon	Perno
3	394367X1	M8	1	Nut, Lock	Écrou de blocage	Tuerca de retención

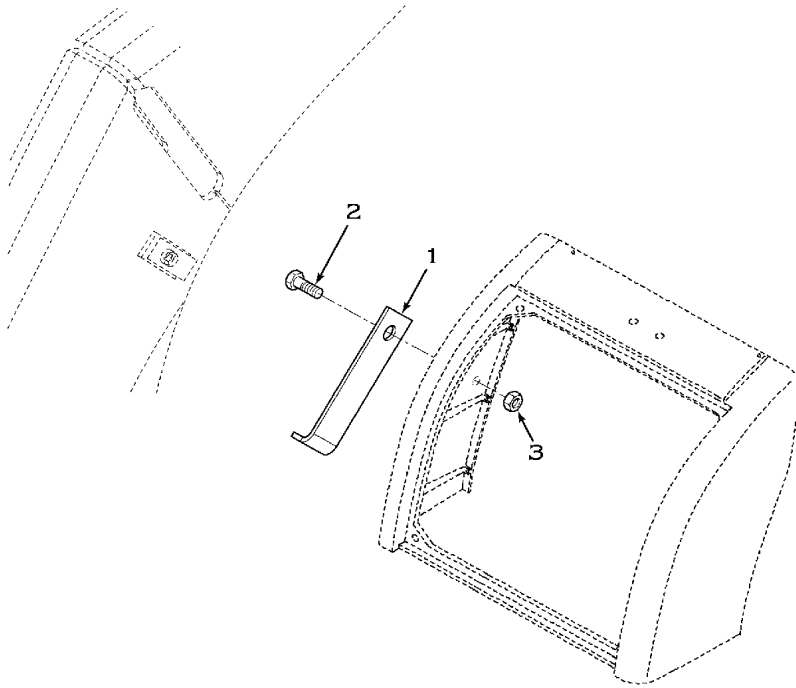

820 860 880 970 980
TX760B TX860B

805 807 817 825 845 855 921 931

95013C01.1

6199042M3

1

Jan-06

Rotating Beacon Kit
Coffret de Feu Intermittent
Juego de luz giratoria

Double
 Double
 Doble

C-98015-01.1-A

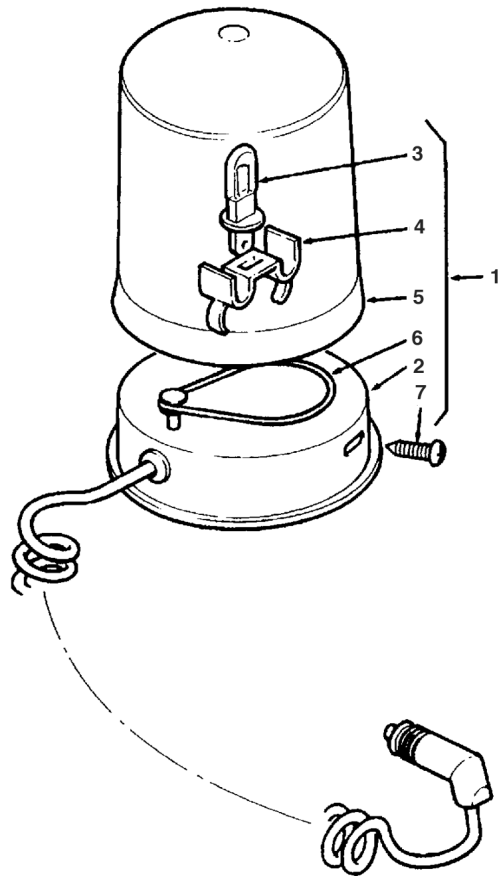

1	3517622M91			2	Beacon, Rotating	Feu intermittent	Luz giratoria
2		1	Ref. 1	1	Base	Embase	Base
3	3523704M1	1	12V - 55W	1	Bulb	Lampe	Lámpara
4	6190229M1	1		1	Support	Support	Soporte
5	6190227M1	1		1	Lens	Lentille	Lente
6	6190228M1	1		1	Belt	Courroie	Correa
7	365915X1	1		1	Screw	Vis	Tornillo



820 860 880 970 980
 TX760B TX860B
 TX870B TX970B

801 803 805 807 813 815 817 821 823 825 831 833 841 843 845 851 853 855 921
 922 923 931 932

98015C01.1

6199042M3

1

Jan-06

Transport Chain
Chaîne de Transport
Cadena de transporte

C-95016-01.1-A

1	3516790M91		1	Chain	Chaîne	Cadena
2	3009505X1	M12 x 25	1	Bolt	Boulon	Perno
3	3516791M1		1	Washer	Rondelle	Arandela

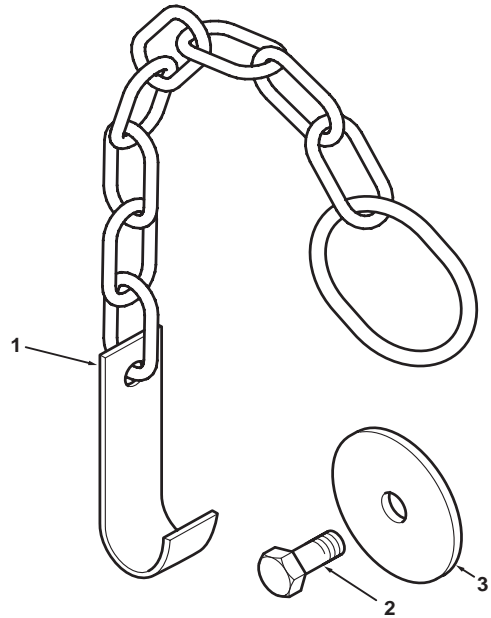

820 860 880 970 980
TX760B TX860B

805 807 817 825 845 855 921 931

Transport Lock
Verrouillage de Transport
Bloqueo de transporte

Loader
Chargeur
Cargadora

C-95017-01.1-A

1	3517949M93		1	Chain	Chaîne	Cadena
2	3517952M91		1	Pin	Axe	Pasador
3	377165X1		1	Pin, Linch	Goupille d'arrêt	Pasador de parada
4	3517961M1		1	Pin, Linch	Goupille d'arrêt	Pasador de parada

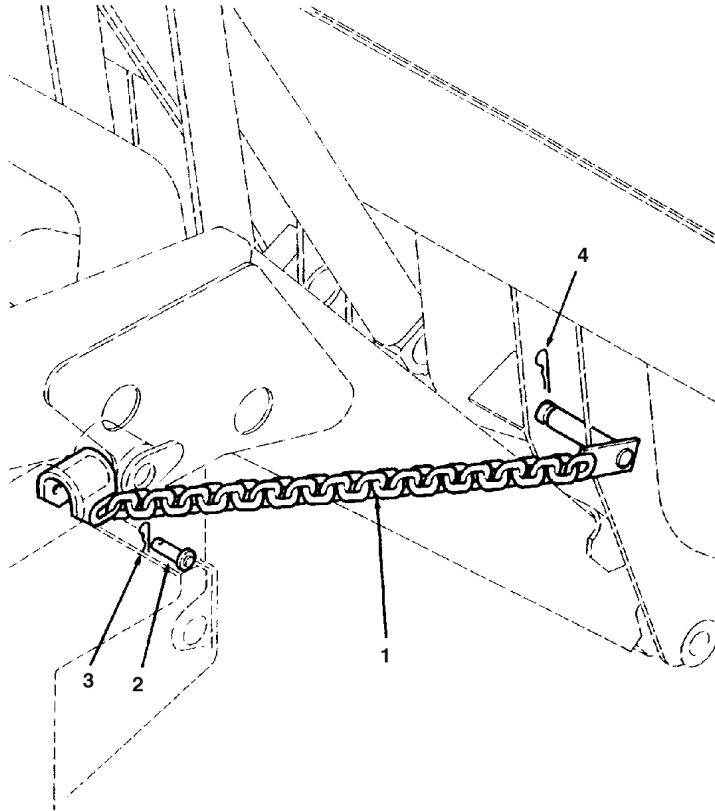

820 860 880 970 980
TX760B TX860B

805 807 817 825 845 855 921 931

95017C01.1

6199042M3

1

Jan-06

Transport Side Plate
Plaque Latérale de Transport
Placa de transporte lateral

Loader
Chargeur
Cargadora

C-95018-01.1-A

1	E2117		①	2	Plate Assy	Ensemble de plaque	Placa, Conj.
2	E47344	1		1	Plate	Plaque	Placa
3	E47346	1		1	Decal	Adhésif	Adhesivo
4	E47345	1		2	Bracket	Patte de fixation	Pata de fijación
5	413-612	1		2	Screw	Vis	Tornillo
6	495-21044	1		2	Washer	Rondelle	Arandela
7	492-11038	1		2	Washer	Rondelle	Arandela
8	425-106	1		2	Nut	Écrou	Tuerca

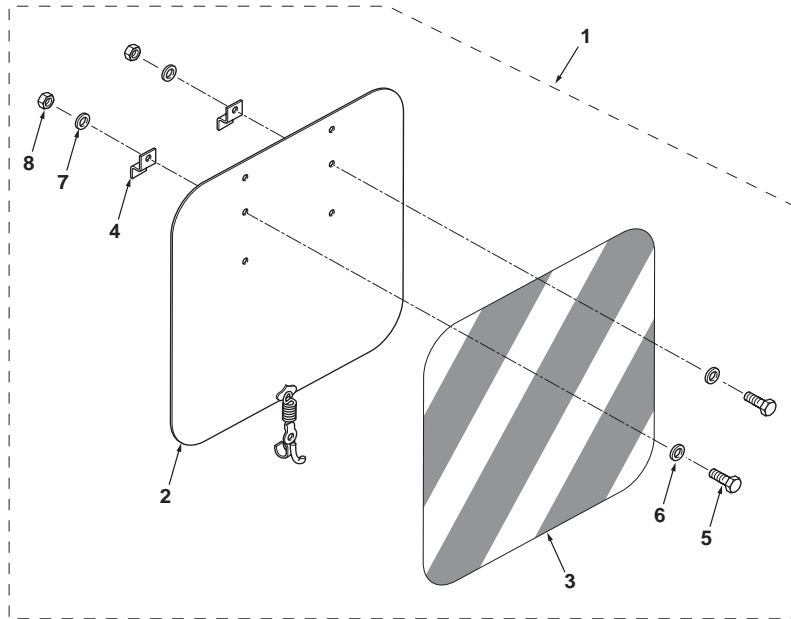

820 860 880 970 980
 TX760B TX860B

805 807 817 825 845 855 921 931

95018C01.1

6199042M3

1

Jan-06

Wheel Wedge
Clavette de Calage de Roue
Calzo de bloqueo de la rueda

C-95012-01.1-A

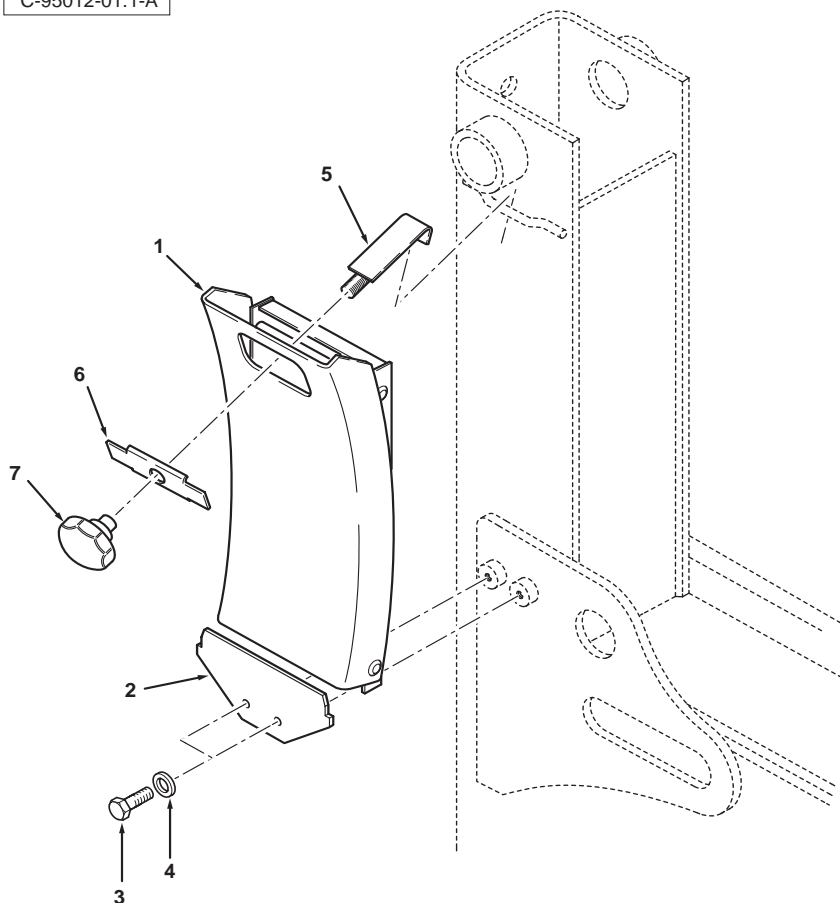

1	3042422M1		1	Wedge	Coin	Calce de bloqueo
2	6102172M1		1	Plate	Plaque	Placa
3	339124X1	M8 x 16	2	Screw	Vis	Tornillo
4	390972X1	M8	2	Washer	Rondelle	Arandela
5	6102196M91		1	Mounting Parts	Pièces de fixation	Piezas de fijación
6	6102192M1		1	Plate	Plaque	Placa
7	3518438M1		1	Handle	Poignée	Asa



820 860 880 970 980
 TX760B TX860B

805 807 817 825 845 855 921 931

95012C01.1

6199042M3

1

Jan-06